

OPERATOR'S MANUAL



Model C043 Frozen Custard Machine

Original Operating Instructions

068359-M

7/22/10 (Original Publication)
(Updated 1/6/2022)

Section 1: To the Installer

Installer Safety	1-1
Site Preparation	1-1
Air-Cooled Machines.....	1-2
Water Connections.....	1-2
Electrical Connections.....	1-2
Beater Rotation	1-3
Refrigerant	1-3

Section 2: To the Operator

Section 3: Safety

Section 4: Operator Parts Identification

C043 Exploded View.....	4-1
Beater Door and Hopper Assemblies.....	4-3
Accessories.....	4-5

Section 5: User Interface

Hopper Refrigeration Switch	5-1
Operational Refrigeration Switch	5-1
Flow Adjustment Knob	5-1
Mix Low Indicator Light	5-1
Beater Motor Switch.....	5-1
Digital Countdown Timer.....	5-1

Section 6: Operating Procedures

Assembly.....	6-1
Sanitizing.....	6-4
Priming.....	6-6
Hold Cycle During Operation	6-8
Resuming Production During Operation	6-9
Preparing for Shutdown	6-10
Rinsing.....	6-11
Cleaning.....	6-13
Disassembly.....	6-14
Brush Cleaning.....	6-15

Section 7: Operator Checklist

During Cleaning and Sanitizing	7-1
Troubleshooting Bacterial Count	7-1
Regular Maintenance Checks	7-1
Winter Storage	7-2

Section 8: Troubleshooting Guide

Section 9: Parts Replacement Schedule

Section 10: Limited Warranty on Equipment

Section 11: Limited Warranty on Parts

The following information has been included in the manual as safety and regulatory guidelines. For complete installation instructions, please see the Installation Checklist.

Installer Safety



IMPORTANT! In all areas of the world, the machine should be installed in accordance with existing local codes. Please contact your local authorities if you have any questions.

Care should be taken to ensure that all basic safety practices are followed during the installation and servicing activities related to the installation and service of Taylor machines.

- Only authorized Taylor service personnel should perform installation and repairs on the machine.
- Authorized service personnel should consult OSHA Standard 29CFR1910.147 or the applicable code of the local area for the industry standards on lockout/tagout procedures before beginning any installation or repairs.
- Authorized service personnel must ensure that the proper personal protective equipment (PPE) is available and worn when required during installation and service.
- Authorized service personnel must remove all metal jewelry, rings, and watches before working on electrical equipment.



DANGER! The main power supply(s) to the machine must be disconnected prior to performing any repairs. Failure to follow this instruction may result in personal injury or death from electrical shock or hazardous moving parts, as well as poor performance or damage to the machine.



WARNING! This machine has many sharp edges that can cause severe injuries.

All repairs must be performed by a Taylor service technician.

Site Preparation

Review the area where the machine will be installed before uncrating the machine. Make sure that all possible hazards to the user and the machine have been addressed.



WARNING! Only install this machine in a location where its use and maintenance is restricted to trained personnel. Failure to comply may result in personal injury.

For Indoor Use Only: This machine is designed to operate indoors under normal ambient temperatures of 70°F to 75°F (21°C to 24°C). The machine has successfully performed in high ambient temperatures of 104°F (40°C) at reduced capacities.



WARNING! This machine must **NOT** be installed in an area where a water jet or hose can be used. **NEVER** use a water jet or hose to rinse or clean the machine. Failure to follow this instruction may result in electrocution.



CAUTION! This machine must be installed on a level surface to avoid the hazard of tipping. Extreme care should be taken in moving this machine for any reason. Two or more persons are required to safely move this machine. Failure to comply may result in personal injury or machine damage.

Air-Cooled Machines

Do not obstruct air intake and discharge openings.

C043: A minimum air clearance of 3 in. (76 mm) is required on the left side and rear of the machine, and 0.0 in. on the right side. The drip tray can be installed on either side. That side requires 36 in. (914 mm) to allow for installation and removal of drip tray. Allow 36 in. (914 mm) at the rear of the machine for service access.

Each air-cooled C043 requires three RC35 remote condensing systems.

RC35: Each 60 Hz remote condenser requires a minimum air clearance of 6 in. (152 mm) on three sides.

Each 50 Hz remote condenser requires a minimum air clearance of 12 in. (305 mm) on three sides.

An air deflector must be installed on the condenser side of each RC35 if the floor clearance is less than 5 in. (127 mm).

Note: *The legs are typically mounted on 4 in. x 4 in. lumber to achieve the minimum floor clearance.*

Failure to allow adequate air clearance can reduce the refrigeration capacity of the machine and possibly cause permanent damage to the compressor.

Water Connections

Water-Cooled Machines Only

An adequate cold water supply must be provided with a hand shutoff valve. On the underside rear of the base pan, two 3/8 in. IPS water connections for inlet and outlet have been provided for easy hookup. Water lines connected to the machine should have 1/2 in. inside diameters. (Flexible lines are recommended, if local codes permit.) Depending on local water conditions, it may be advisable to install a water strainer to prevent foreign substances from clogging the automatic water valve. There will be only one water-in and one water-out connection. **Do not** install a hand shutoff valve on the water-out line! Water should always flow in this order: first, through the automatic water valve; second, through the condenser; and third, through the outlet fitting to an **open trap drain**.

Minimum water pressure is 30 psi (207 kPa) and maximum water pressure is 150 psi (1034 kPa).

C043: The minimum air clearance requirement is 3 in. (76 mm) on both sides and at the rear of the machine. The drip tray can be installed on either side. That side requires 36 in. (914 mm) to allow for the installation and removal of the drip tray. Allow 36 in. (914 mm) at the rear of the machine for service access.



IMPORTANT! *A backflow prevention device is required on the incoming water connection side. Please see the applicable national, state, and local codes for determining the proper configuration.*

Electrical Connections

Each machine requires one power supply for each data label on the machine. Check the data label(s) on the machine for branch circuit overcurrent protection or fuse, circuit ampacity, and other electrical specifications. See the wiring diagram provided inside the electrical box for proper power connections.

In the United States, this machine is intended to be installed in accordance with the National Electrical Code (NEC) ANSI/NFPA 70-1987. The purpose of the NEC code is the practical safeguarding of persons and property from hazards arising from the use of electricity. This code contains provisions considered necessary for safety. Compliance therewith and proper maintenance will result in an installation essentially free from hazard!

In all other areas of the world, machines should be installed in accordance with the existing local codes. Please contact your local authorities.



FOLLOW YOUR LOCAL ELECTRICAL CODES.



WARNING! This machine must be properly grounded! Failure to do so can result in severe personal injury from electrical shock!



IMPORTANT! This machine is provided with an equipotential grounding lug that is to be properly attached to the rear of the frame by the authorized installer. The installation location is marked by the equipotential bonding symbol (5021 of IEC 60417-1) on the removable panel and the machine's frame.



NOTICE!

- Stationary machines which are not equipped with a power cord and a plug or another device to disconnect the machine from the power source must have an all-pole disconnecting device with a contact gap of at least 0.125 in. (3 mm) installed in the external installation.
- Machines that are permanently connected to fixed wiring and for which leakage currents may exceed 10 mA, particularly when disconnected or not used for long periods, or during initial installation, shall have protective devices to protect against the leakage of current, such as a GFI, installed by the authorized personnel to the local codes.
- Supply cords used with this machine shall be oil-resistant, sheathed flexible cable not lighter than ordinary polychloroprene or other equivalent synthetic elastomer-sheathed cord (code designation 60245 IEC 57) installed with the proper cord anchorage to relieve conductors from strain, including twisting, at the terminals and protect the insulation of the conductors from abrasion.
- If the supply cord is damaged, it must be replaced by the manufacturer, service agent, or a similarly qualified person, in order to avoid a hazard.

Beater Rotation



NOTICE! Beater rotation must be counterclockwise as viewed looking into the freezing cylinder.

If the beater rotation is not counterclockwise, contact your local authorized Taylor service technician.

1

Refrigerant



CAUTION! This machine contains fluorinated greenhouse gases (F-Gas) to provide refrigeration using a hermetically sealed circuit or within foam insulation. This machine's type of gas, quantity, Global Warming Potential (GWP), and CO₂ tonnes equivalent information is recorded on the unit's data-label. The refrigerant used is generally considered non-toxic and non-flammable. However any gas under pressure is potentially hazardous and must be handled with caution.

NEVER fill any refrigerant cylinder completely with liquid. Filling the cylinder to approximately 80% will allow for normal expansion.



CAUTION! Use only approved refrigerant listed on the machine's data-label or authorized through a manufacturer's technical bulletin. The use of any other refrigerant may expose users and operators to unexpected safety hazards.



WARNING! Refrigerant liquid sprayed onto the skin may cause serious damage to tissue. Keep eyes and skin protected. If refrigerant burns should occur, flush the area immediately with cold water. If burns are severe, apply ice packs and contact a physician immediately.



NOTICE! Taylor reminds technicians to be aware of government laws regarding refrigerant recovery, recycling, and reclaiming systems. If you have any questions regarding these laws, please contact the factory service department.

1



IMPORTANT! *Refrigerants and their associated lubricants may be extremely moisture absorbent. When opening a refrigeration system, the maximum time the system is open must not exceed 15 minutes. Cap all open tubing to prevent humid air or water from being absorbed by the oil.*

The machine you have purchased has been carefully engineered and manufactured to give you dependable operation. The Taylor machine, when properly operated and cared for, will produce a consistent quality product. Like all mechanical products, this machine will require cleaning and maintenance. A minimum amount of care and attention is necessary if the operating procedures outlined in this manual are followed closely.



IMPORTANT! This manual should be read before operating or performing any maintenance on your machine.

Your Taylor machine will **not** eventually compensate and correct for any errors during the setup or filling operations. Thus, the initial assembly and priming procedures are of extreme importance. It is strongly recommended that all personnel responsible for the machine's operation review these procedures in order to be properly trained and to make sure that there is no confusion.

In the event you should require technical assistance, please contact your local authorized Taylor distributor.

Note: Your Taylor warranty is valid only if the parts are authorized Taylor parts, purchased from the local authorized Taylor distributor, and only if all required service work is provided by an authorized Taylor service technician. Taylor reserves the right to deny warranty claims on machines or parts if unapproved Taylor parts or incorrect refrigerant were installed in the machine, system modifications were performed beyond factory recommendations, or it is determined that the failure was caused by abuse, misuse, neglect, or failure to follow all operating instructions. For full details of your Taylor warranty, please see the Limited Warranty section in this manual.

Note: Constant research results in steady improvements; therefore, information in this manual is subject to change without notice.



IMPORTANT! If the crossed-out waste container symbol is affixed to this product, it signifies that this product is compliant with the EU Directive as well as other similar legislation in effect after August 13, 2005. Therefore, it must be collected separately after its use is completed, and cannot be disposed as unsorted municipal waste.

The user is responsible for delivering the product to the appropriate collection facility, as specified by your local code.

For additional information regarding applicable local laws, please contact the municipal facility and/or local authorized Taylor distributor.

Compressor Warranty Disclaimer

The refrigeration compressor(s) on this machine are warranted for the term stated in the Limited Warranty section in this manual. However, due to the Montreal Protocol and the U.S. Clean Air Act Amendments of 1990, many new refrigerants are being tested and developed, thus seeking their way into the service industry. Some of these new refrigerants are being advertised as drop-in replacements for numerous applications. It should be noted that in the event of

2 ordinary service to this machine's refrigeration system, **only the refrigerant specified on the affixed data label should be used.** The unauthorized use of alternate refrigerants will void your Taylor compressor warranty. It is the machine owner's responsibility to make this fact known to any technician he or she employs.

It should also be noted that Taylor does not warrant the refrigerant used in its equipment. For example, if the refrigerant is lost during the course of ordinary service to this machine, Taylor has no obligation to either supply or provide its replacement either at billable or non-billable terms. Taylor does have the obligation to recommend a suitable replacement if the original refrigerant is banned, obsoleted, or no longer available during the five-year warranty of the compressor.

Taylor Company will continue to monitor the industry and test new alternates as they are being developed. Should a new alternate prove, through our testing, that it would be accepted as a drop-in replacement, then the above disclaimer would become null and void. To find the current status of an alternate refrigerant as it relates to your compressor warranty, call the local Taylor distributor or the Taylor factory. Be prepared to provide the model/serial number of the machine in question.

We at Taylor Company are concerned about the safety of the operator when he or she comes in contact with the machine and its parts. Taylor has gone to extreme efforts to design and manufacture built-in safety features to protect both you and the service technician. As an example, warning labels have been attached to the machine to further point out safety precautions to the operator.



DANGER! Failure to adhere to the following safety precautions may result in severe personal injury or death. Failure to comply with these warnings may also damage the machine and/or its components. Such damage may require component replacement and service repair expenses.



NOTICE! DO NOT operate the machine without reading the Operator Manual. Failure to follow this instruction may result in machine damage, poor machine performance, health hazards, or personal injury.



IMPORTANT! *This machine is to be used only by trained personnel. It is not intended for use by children or people with reduced physical, sensory, or mental capabilities, or lack of experience and knowledge, unless given supervision or instruction concerning the use of the machine by a person responsible for their safety. Children should be supervised to ensure that they do not play with the machine.*



WARNING! This machine must **NOT** be installed in an area where a water jet or hose can be used. **NEVER** use a water jet or hose to rinse or clean the machine. Failure to follow this instruction may result in electrocution.



IMPORTANT! This machine is provided with an equipotential grounding lug that is to be properly attached to the rear of the frame by the authorized installer. The installation location is marked by the equipotential bonding symbol (5021 of IEC 60417-1) on the removable panel and the machine's frame.



WARNING! DO NOT use a water jet to clean or rinse the machine. Failure to follow these instructions may result in serious electrical shock.



WARNING! Avoid injury.

- **DO NOT** operate the machine unless it is properly grounded.
- **DO NOT** operate machine with larger fuses than specified on the data label.
- All repairs must be performed by an authorized Taylor service technician.
- The main power supplies to machine must be disconnected prior to performing repairs.
- **For Cord-Connected Machines:** Only authorized Taylor service technicians or licensed electricians may install a plug or replacement cord on the machine.
- Stationary machines which are not equipped with a power cord and a plug or another device to disconnect the machine from the power source must have an all-pole disconnecting device with a contact gap of at least 0.125 in. (3 mm) installed in the external installation.
- Machines that are permanently connected to fixed wiring and for which leakage currents may exceed 10 mA, particularly when disconnected or not used for long periods, or during initial installation, shall have protective devices to protect against the leakage of current, such as a

GFI, installed by the authorized personnel to the local codes.

- Supply cords used with this machine shall be oil-resistant, sheathed flexible cable not lighter than ordinary polychloroprene or other equivalent synthetic elastomer-sheathed cord (code designation 60245 IEC 57) installed with the proper cord anchorage to relieve conductors from strain, including twisting, at the terminals and protect the insulation of the conductors from abrasion.
- If the supply cord is damaged, it must be replaced by the manufacturer, service agent, or a similarly qualified person, in order to avoid a hazard.

3

Failure to follow these instructions may result in electrocution. Contact your local authorized Taylor distributor for service.



WARNING! Avoid injury.

- **DO NOT** allow untrained personnel to operate this machine.
- **DO NOT** put objects or fingers in the door spout.
- **DO NOT** operate the machine unless all service panels and access doors are restrained with screws.
- **DO NOT** remove the machine door or beater assembly unless the control switches are in the OFF position.

Failure to follow these instructions may result in contaminated product or severe personal injury to fingers or hands from hazardous moving parts.



WARNING! This machine has many sharp edges that can cause severe injuries.

Examples:

- Scraper blades
- Condenser fins



CAUTION! This machine must be placed on a level surface. Failure to comply may result in personal injury or machine damage.



WARNING! Only install this machine in a location where its use and maintenance is restricted to trained personnel. Failure to comply may result in personal injury.



IMPORTANT! Access to the service area of the machine is restricted to persons having knowledge and practical experience with the machine, in particular as far as safety and hygiene are concerned.



NOTICE! Cleaning and sanitizing schedules are governed by your federal, state, or local regulatory agencies and must be followed accordingly. Please see the cleaning section of this manual for the proper procedure to clean this machine.



CAUTION! This machine is designed to maintain product temperature under 41°F (5°C). Any product being added to this machine must be below 41°F (5°C). Failure to follow this instruction may result in health hazards and poor machine performance.

For Indoor Use Only: This machine is designed to operate indoors, under normal ambient temperatures of 70°F to 75°F (21°C to 24°C). The machine has successfully performed in high ambient temperatures of up to 104°F (40°C) at reduced capacities.

Do not run the machine without product. Failure to follow this instruction can result in damage to the machine.

NOISE LEVEL: Airborne noise emission does not exceed 78 dB(A) when measured at a distance of 1.0 meter from the surface of the machine and at a height of 1.6 meters from the floor.

Minimum Air Clearances: Air-Cooled Machines

Do not obstruct air intake and discharge openings:

C043: A minimum air clearance of 3 in. (76 mm) is required on the left side and rear of the machine, and 0.0 in. on the right side. The drip tray can be installed on either side. That side requires 36 in. (914 mm) to allow for installation and removal of drip tray. Allow 36 in. (914 mm) at the rear of the machine for service access.

Failure to follow this instruction may cause poor machine performance and damage to the machine.

Each air-cooled C043 requires three RC35 remote condensing systems.

RC35 (used with air-cooled C043 machine only):

Each 60 Hz remote condenser requires a minimum air clearance of 6 in. (152 mm) on three sides.

Each 50 Hz remote condenser requires a minimum air clearance of 12 in. (305 mm) on three sides.

An air deflector must be installed on the condenser side of each RC35 if the floor clearance is less than 5 in. (127 mm).

Note: *The legs are typically mounted on 4 in. x 4 in. lumber to achieve the minimum floor clearance.)*

Failure to allow adequate air clearance can reduce the refrigeration capacity of the machine and possibly cause permanent damage to the compressor.

Minimum Air Clearances: Water-Cooled Machines

C043: The minimum air clearance requirement is 3 in. (76 mm) on both sides and at the rear of the machine. The drip tray can be installed on either side. That side requires 36 in. (914 mm) to allow for the installation and removal of the drip tray. Allow 36 in. (914 mm) at the rear of the machine for service access.

C043 Exploded View

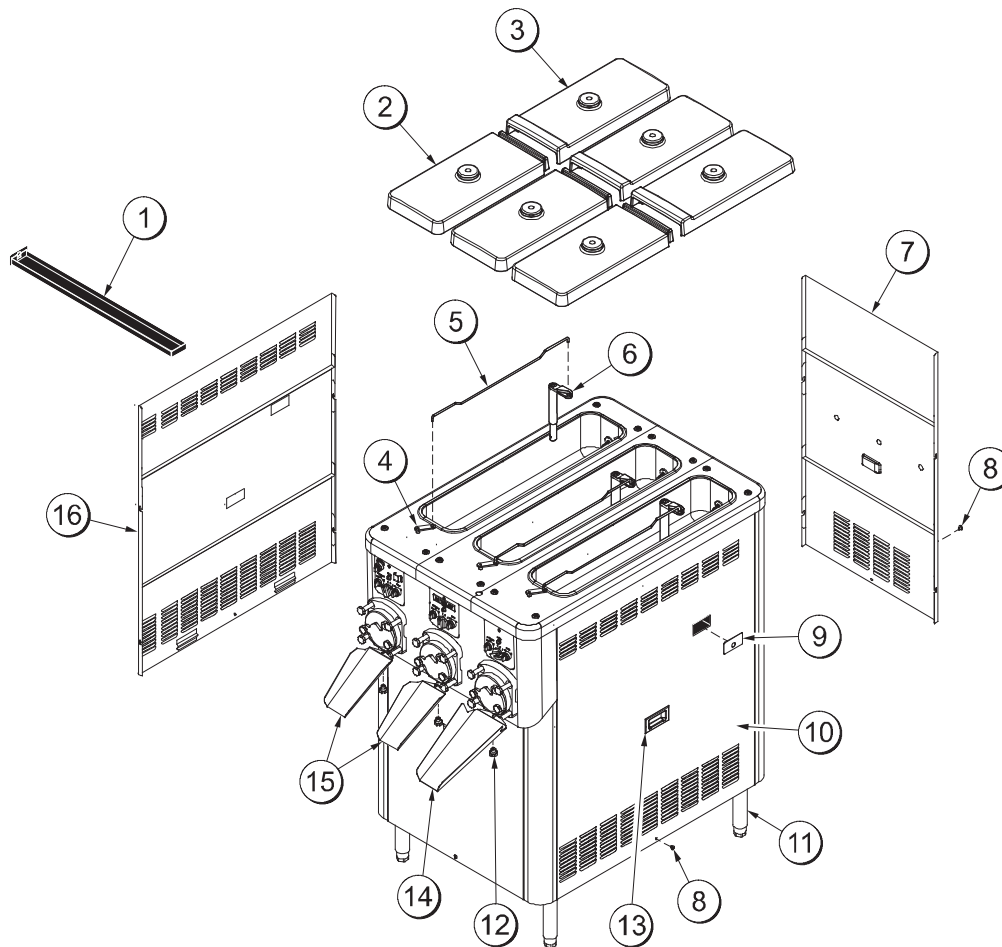

Figure 4-1

C043 Exploded View Parts Identification

Item	Description	Part No.
1	Tray A.-Drip	X63636
2	Cover-Hopper-Front INS	065701
3	Cover-Hopper-Rear INS	065700
4	Lever A.-Flow Reg	X66923
5	Rod-Flow Control	063593
6	Tube A.-Feed Plastic	X67453
7	Panel A.-Rear	X63715
8	Screw-1/4-20X3/8 PHIL TRUSS	038872

Item	Description	Part No.
9	Cover A.-Panel-Side	X65637
10	Panel A.-Side Right	X63720
11	Leg-8" 2"OD-3/4-10 Stud-Hex	044652
12	Nut-Stud	043666
13	Handle-STNLS Flush Pull	019043
14	Chute-Long	063619
15	Chute-Short	063618
16	Panel A.-Side Left	X63724

Beater Door and Hopper Assemblies

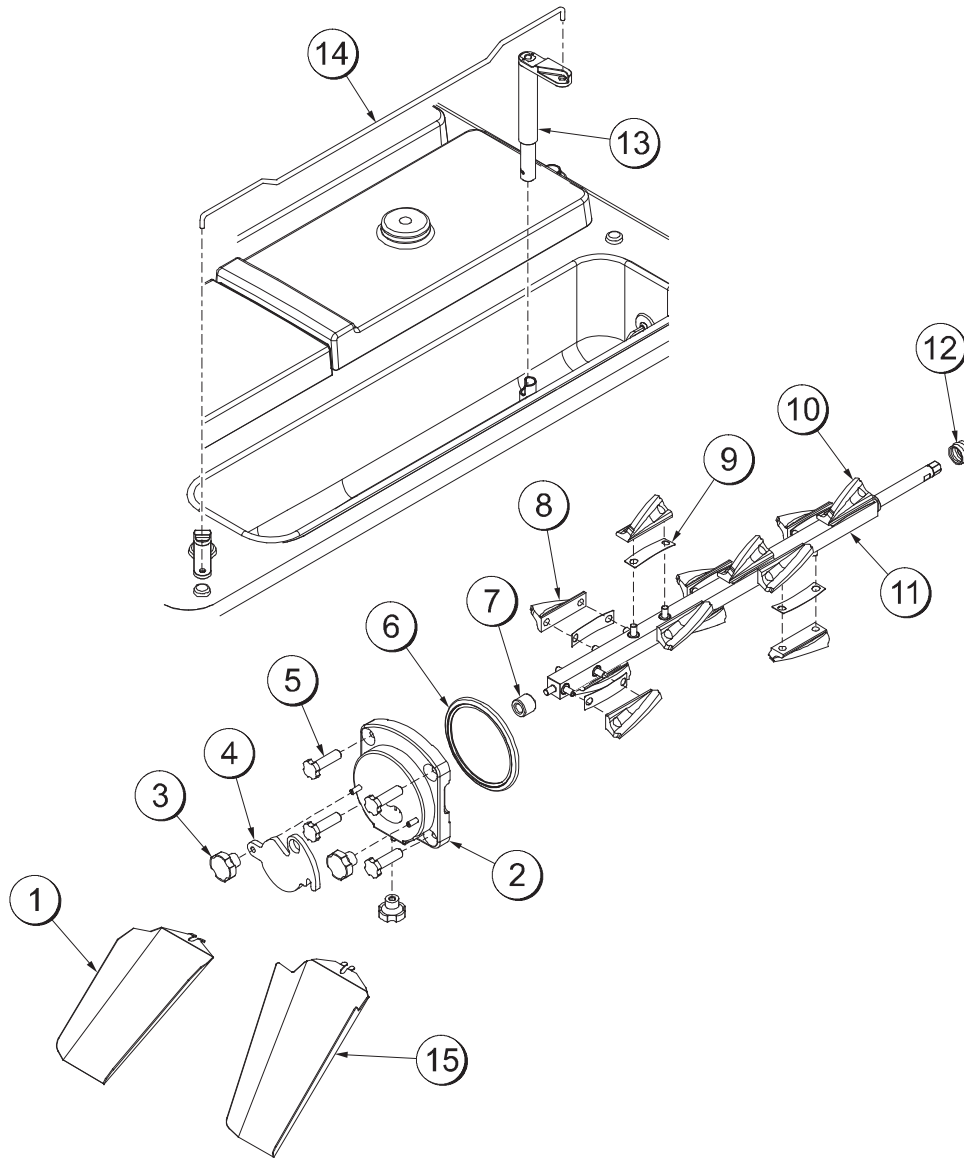

4

Figure 4-2

Beater Door and Hopper Assemblies Parts Identification

Item	Description	Part No.
1	Chute	063618
2	Door Assembly	X63611-SER
3	Nut-Stud	043666
4	Plate-Draw Arm	063614
5	Nut-Stud	034383
6	Gasket-Door HT 4IN-DBL	048926
7	Bearing-Door-Front	064315
8	Blade-Scraper 30 Pitch	063656

Item	Description	Part No.
9	Spring-Dasher Blade	063693
10	Blade-Scraper-Rear	063640
11	Dasher A.-Custard	X83275
12	Seal-Drive Shaft	032560
13	Tube A.-Feed Plastic	X67453
14	Rod-Flow Control	063593
15	Chute-Long	063619

Accessories

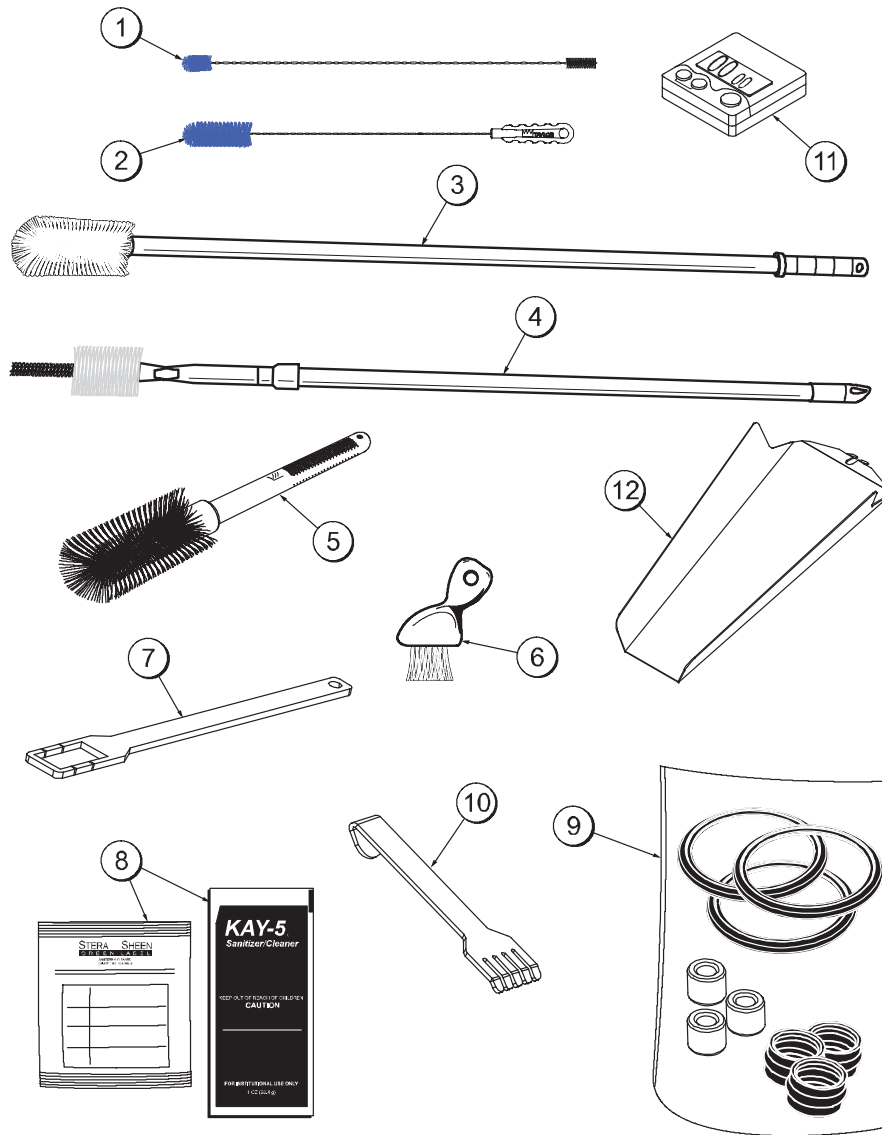

Figure 4-3

Item	Description	Part No.
1	Brush-Dbl End-Pump & Feed	013072
2	Brush-Draw Valve 1"OD X 2"X17"	013073
3	Brush-Barrel	063843
4	Brush-Rear BRG.	063844
5	Brush-Mix Pump Body 3"X7"	023316
6	Brush-End-Door-Spout-SS	039719

Item	Description	Part No.
7	Tool-Dasher Shaft Remove	063623
*8	Sanitizer	See Note
9	Kit A.- Tune Up	X64743
10	Rake-Blade Guard	064888
11	Timer-Countdown-Digital	065425
12	Chute-Long	063619

*A sample of sanitizer is sent with the machine. For reorders, order Stera Sheen® Part No. 055492 (100 packs) or Kay-5® Part No. 041082 (125 Packs).

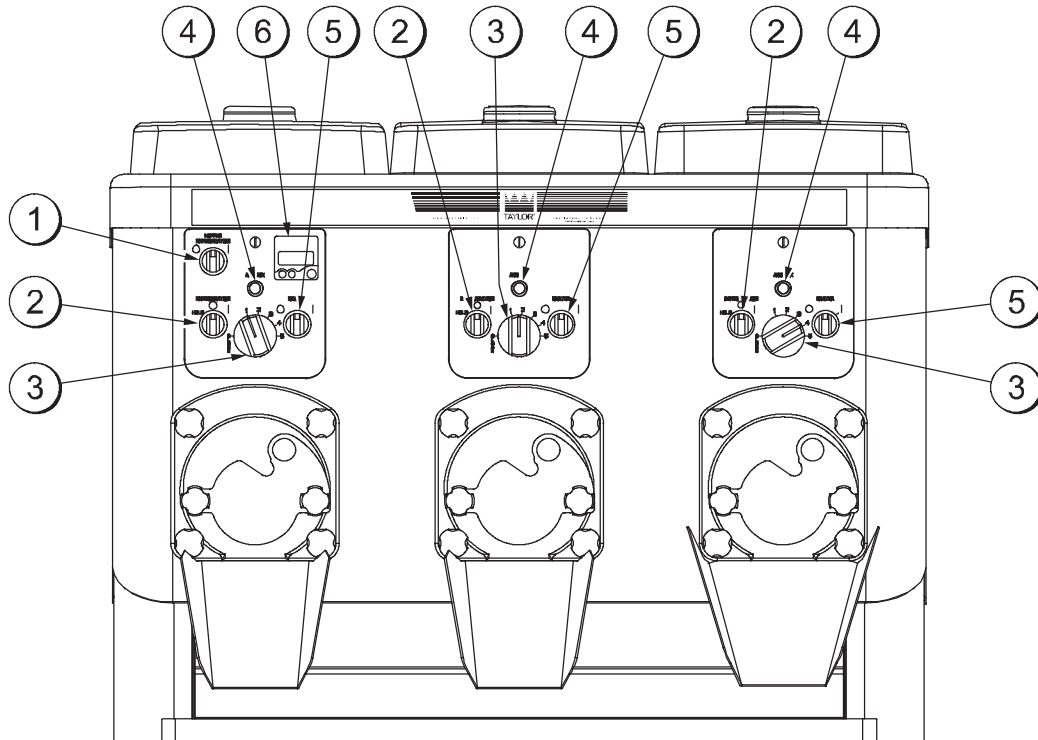

Figure 5-1

Item	Description
1	Hopper Refrigeration Switch
2	Operational Refrigeration Switch
3	Flow Adjustment Knob
4	MIX LOW Indicator Light
5	Beater Motor Switch
6	Digital Countdown Timer

Hopper Refrigeration Switch

The hopper refrigeration switch activates the hopper refrigeration.

Operational Refrigeration Switch

Place the operational refrigeration switch in the ON position to allow the product to dispense. During no sale periods, place the switch in the HOLD position to keep the product refrigerated in the freezing cylinder.

Flow Adjustment Knob

The flow adjustment knob adjusts the flow of product into the freezing cylinders.

Note: Whenever an adjustment is made, first turn the adjustment knob all the way to 5 and then back to the desired number.

Mix Low Indicator Light

When the mix low indicator light is illuminated, the mix hopper has a low supply of mix and should be refilled as soon as possible.

Beater Motor Switch

The beater motor switch activates the beater motor.

Digital Countdown Timer

The digital countdown timer is used to keep track of the time needed to control product quality.

The Model C043 is a three-flavor custard machine. It has three 30 qt. (28 L) hoppers. Mix flows by gravity through an adjustable flow regulator into the freezing cylinders. This machine has been designed to produce rich-tasting custard product that can be drawn off and served from a holding cabinet. The overrun is typically 20% to 25% and varies depending on the mix formulation and the finished product temperature 18°F to 21°F (-7.8°C to -6.1°C).

We begin our instructions at the point where we find the parts disassembled and laid out to air-dry from the previous brush cleaning.

The following procedures will show you how to assemble the parts into the machine, sanitize them, and prime the machine with fresh mix.

If you are disassembling the machine for the first time or need information to get to this starting point in our instructions, go to “Disassembly” on page 6-14 and start there.

Assembly



WARNING! Make sure the power switch is in the OFF position! Failure to follow this instruction may result in severe personal injury to fingers or hands from hazardous moving parts.

Beater Shaft, Scraper Blade, and Feed Tube Assembly

1. Verify that the refrigeration switch and the beater motor switch are both in the OFF position.

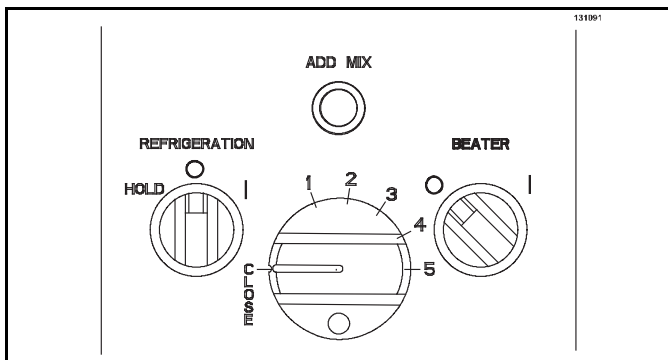

Figure 6-1

2. Place a bead of lubricant around the groove of the beater shaft.

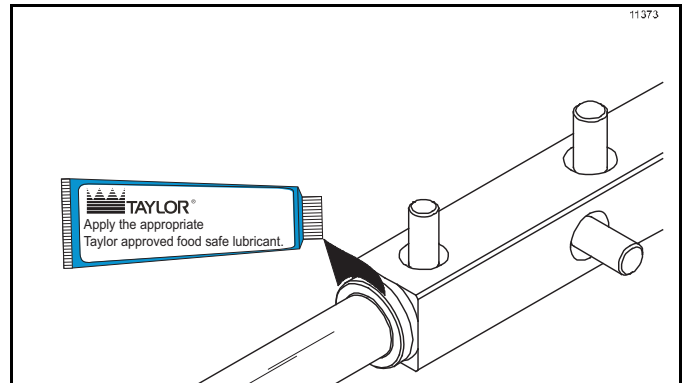

Figure 6-2

Note: When lubricating parts, use an approved food grade lubricant (example: Taylor Lube).

3. Slide the seal over the shaft and groove until it snaps into place.

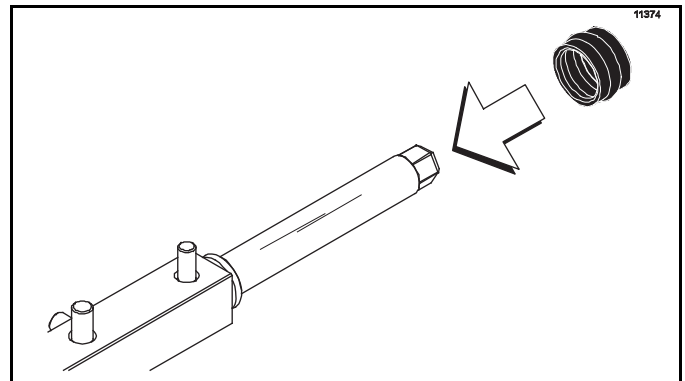

Figure 6-3

4. Fill the inside portion of the seal with 1/4 in. (6 mm) more lubricant and lubricate the flat side of the seal that fits onto the rear shell-bearing.

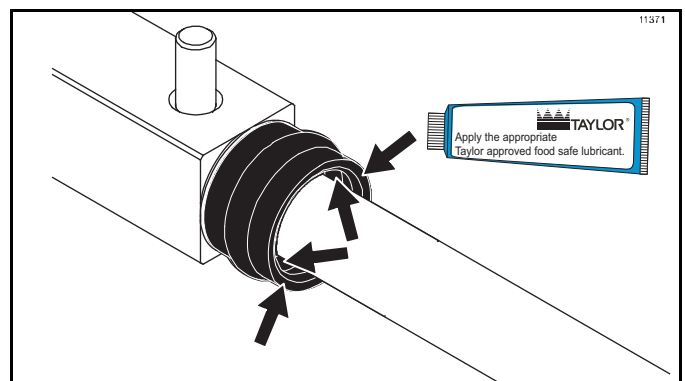

Figure 6-4

OPERATING PROCEDURES

- Lubricate the beater shaft.

Important! Do not lubricate the hex end of the beater shaft.

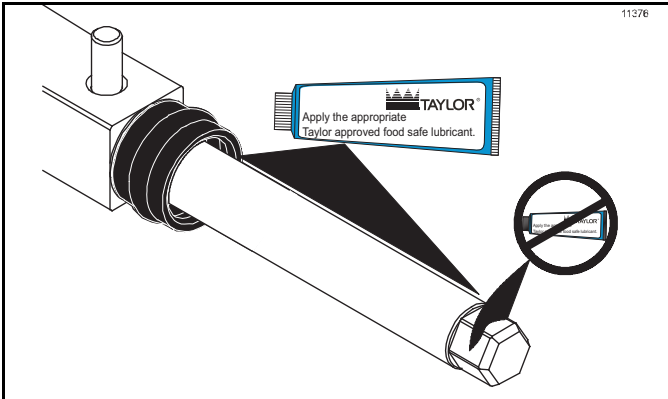

Figure 6-5

- Inspect each scraper blade for any nicks or signs of excessive wear. If any nicks or signs of wear are present, replace the blade.

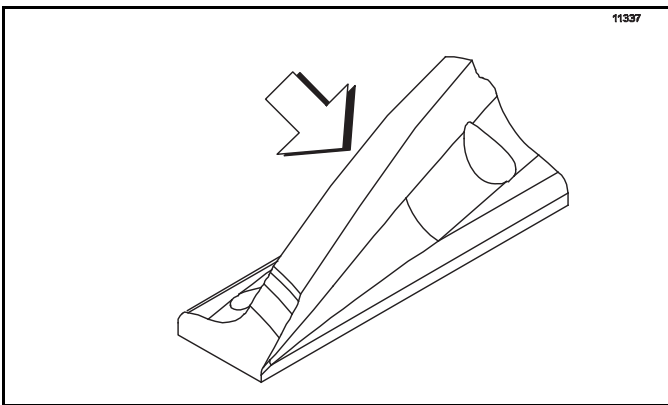

Figure 6-6

- Starting at the hex end of the beater shaft, place a metal leaf spring (arched upward) over the two pins closest to that end. Install the long scraper blade on top of the leaf spring.

Note: There is only one long scraper blade per beater.

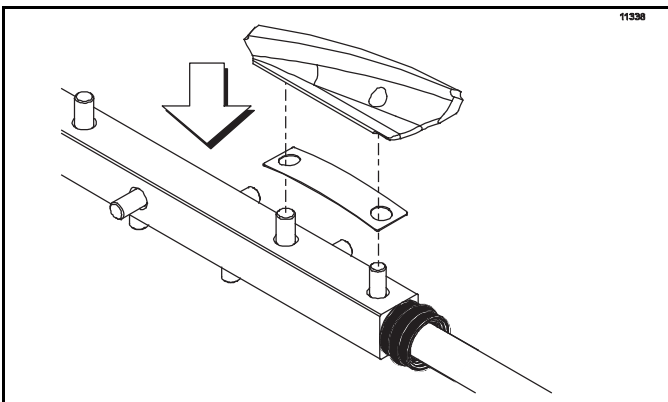

Figure 6-7

- Place a leaf spring and a short scraper blade on the next set of pins.
- Hold the two leaf springs and scraper blades in place. Slide the beater shaft into the freezing cylinder until the scraper blades are held in place by the freezing cylinder. Rotate the beater shaft counterclockwise until the next set of pins is facing up.

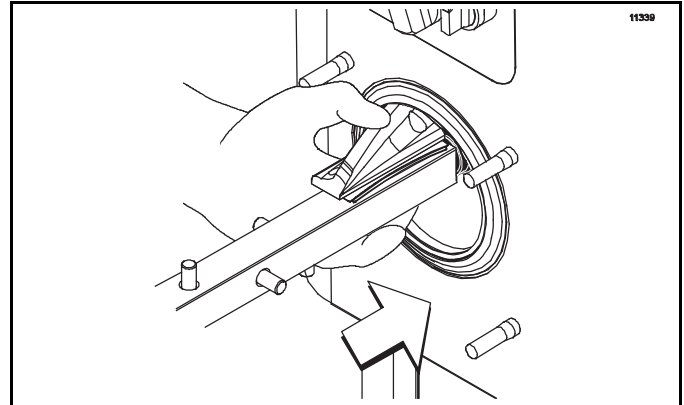

Figure 6-8

- Place a leaf spring and a short scraper blade on the next set of pins. Slide the beater shaft into the freezing cylinder until the blade is held in place by the freezing cylinder. Rotate the beater shaft counterclockwise until the next set of pins is facing up.
- Continue adding leaf springs and short scraper blades to the beater shaft until all 12 blades are installed.
- Slide the beater shaft into the freezing cylinder, rotating the beater shaft slightly counterclockwise. Engage the hex end firmly into the drive coupling at the back of the machine. The square portion of the beater shaft assembly should fit completely inside the freezing cylinder. The bearing support pin will extend beyond the freezing cylinder.

Note: It may be helpful to use the beater removal tool to turn the beater while installing it.

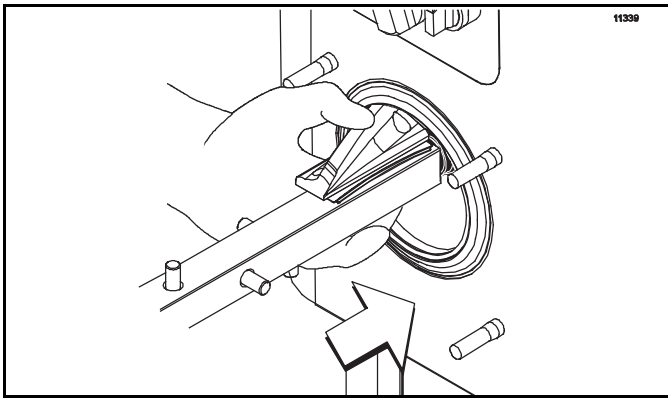

Figure 6-9

Note: The drip pan is a convenient place to store the beater removal tool.

13. Install the front bearing on the bearing support pin.

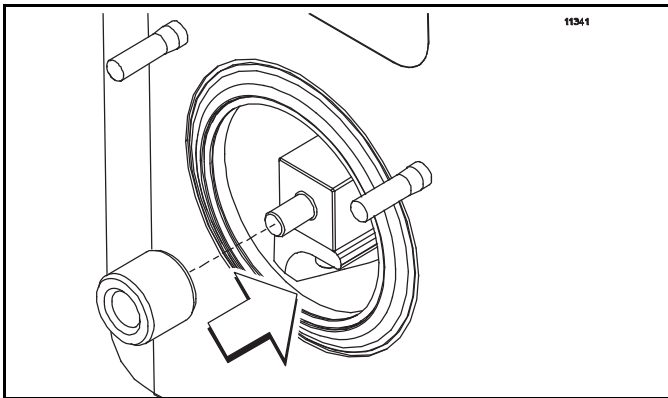

Figure 6-10

14. Repeat steps 1 to 13 on the remaining freezing cylinders.

Door Assembly

1. With the door in a horizontal position, install the draw arm plate. Install all three short stud nuts and leave them loose.

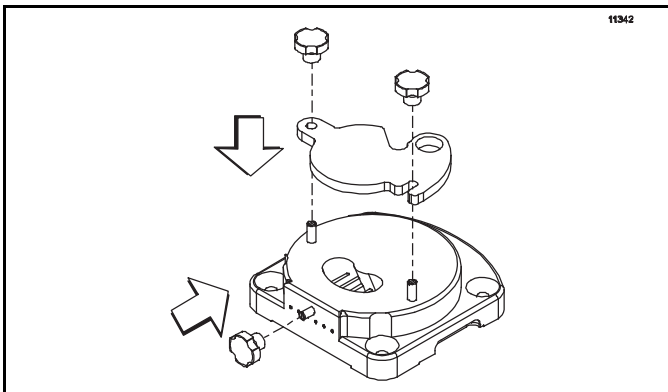

Figure 6-11

2. Turn the door over and install the door gasket.

Note: Do not lubricate the gasket, as this will cause the gasket to leak over time.

3. Press all around the gasket to ensure a flush, secure fit in the groove. The gasket may have to be stretched slightly to get it into the proper position.

To make sure that the gasket is correctly positioned, verify that the middle section of the gasket is arched upward. If the middle section of the gasket is concave, or extends into the middle of the seal, turn the gasket over, as it is upside down.

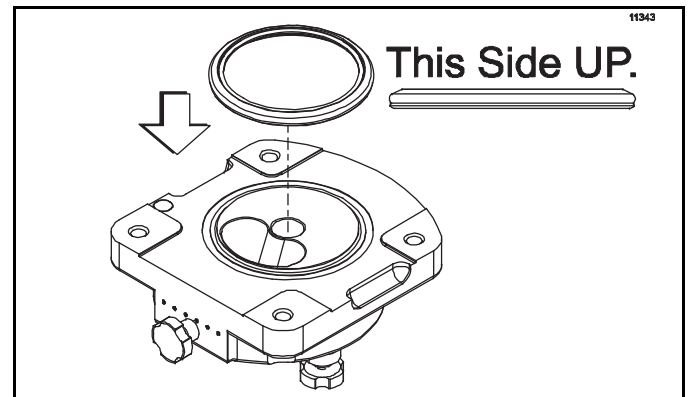

Figure 6-12

4. Seat the door on the freezer studs. To make sure the door gasket doesn't fall off, hold the door flush with the freezing cylinder with one hand while installing the stud nuts with the other hand. Hand-tighten the stud nuts equally in a crisscross pattern to make sure the door is secured.

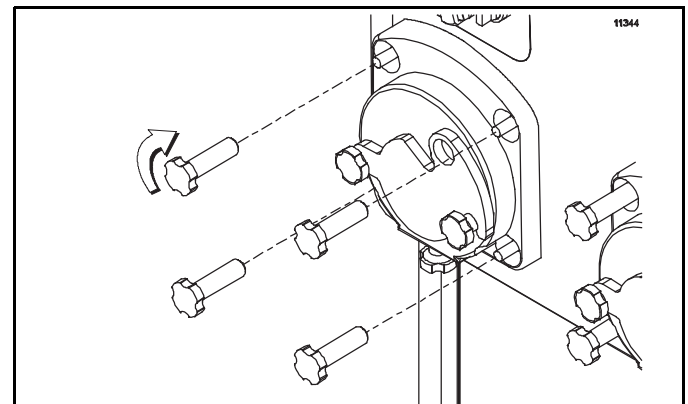

Figure 6-13

5. Repeat steps 1 to 4 on the remaining freezing cylinders.

Sanitizing

1. Prepare an approved 100 PPM sanitizing solution (examples: 5 gal. [19 L] of Kay- 5[®] or 4 gal. [15 L] of Stera-Sheen[®]).

Important! Use warm water and follow the manufacturer's specifications.

2. Place the feed tube and the flow control rod flat on the bottom of the hopper.

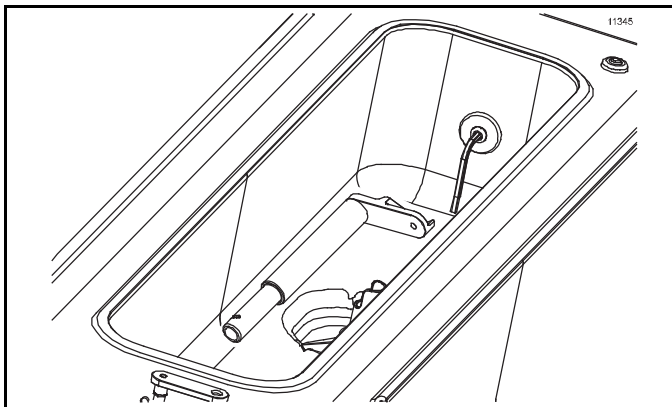

Figure 6-14

3. Place the product chutes in the hopper.

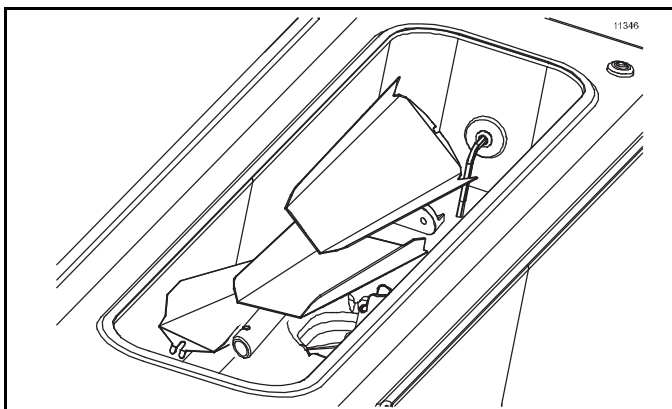

Figure 6-15

4. Make sure the draw arm plate is closed and the short door stud nuts are secured.

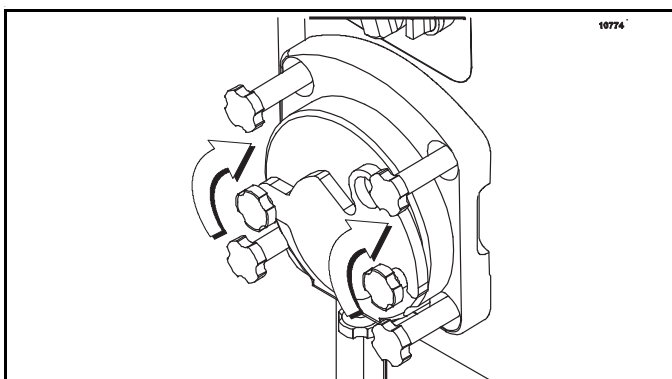

Figure 6-16

5. Attach the splash guards to the door studs.

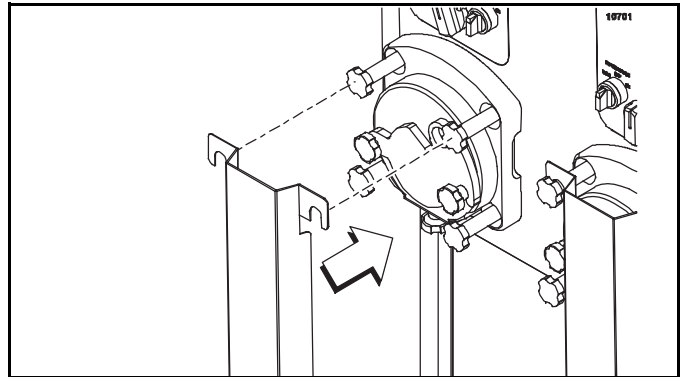

Figure 6-17

6. Make sure the refrigeration switch and the hopper refrigeration switch are in the OFF position.

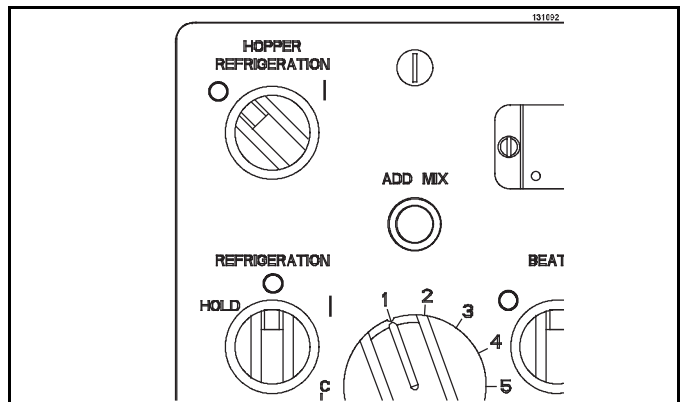

Figure 6-18

Important! Refrigeration should **not** be on when water is present in the freezing cylinder or hopper.

7. Place an empty pail under the draw arm plate (if the machine is not equipped with a trough).

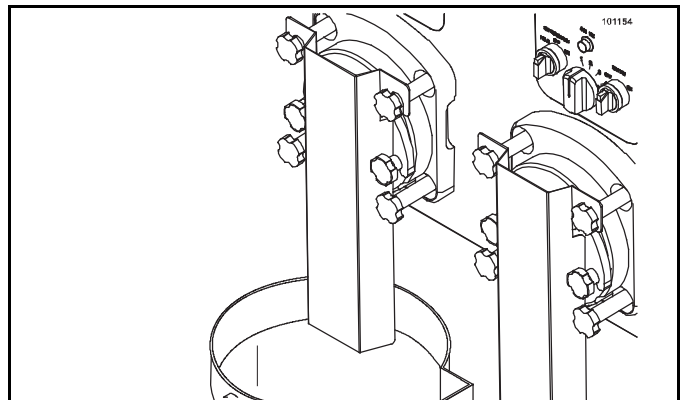

Figure 6-19

8. Pour the sanitizing solution into the hopper.

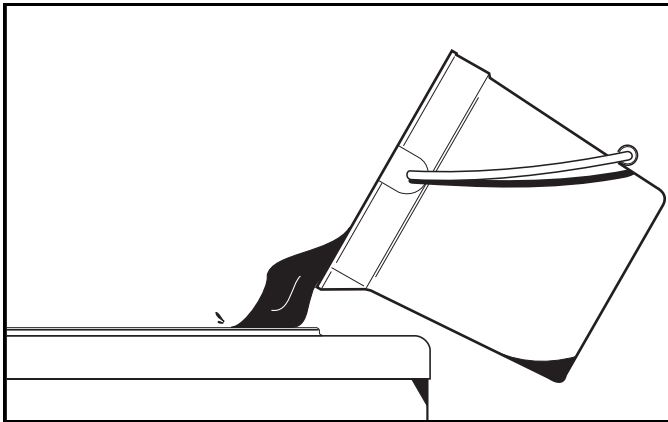

Figure 6-20

9. Brush clean the mix hopper.

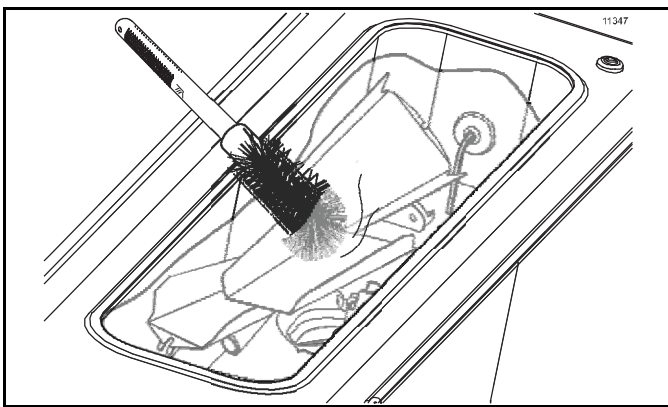

Figure 6-21

10. Place the beater switch in the ON position and set the timer for 5 minutes.

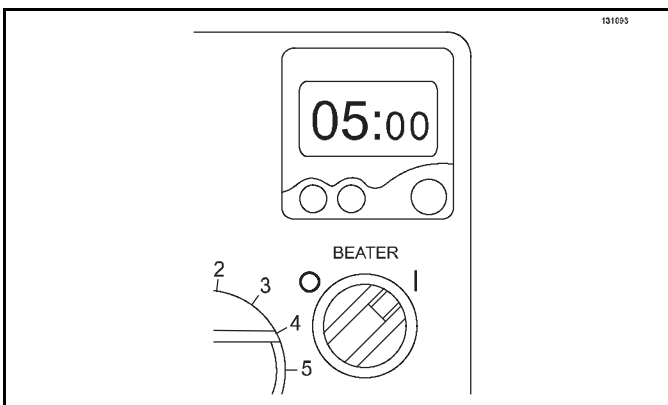

Figure 6-22

11. After 5 minutes have elapsed, open the draw arm plate and drain the sanitizer into the empty pail.
- Note:** If your machine is equipped with a trough, drain the sanitizer into the trough.
12. Place the beater switch in the OFF position and the flow adjustment knob in the CLOSE position.

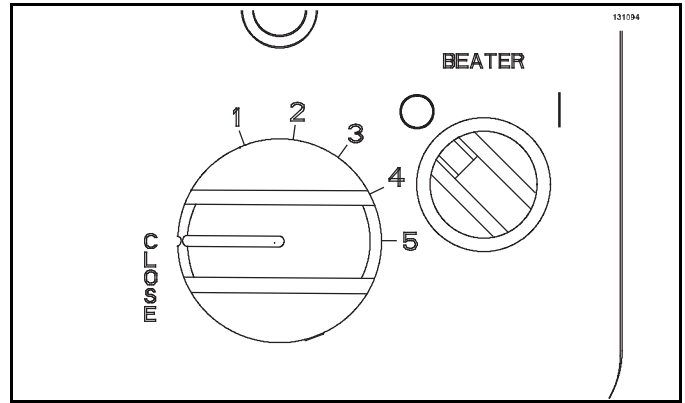

Figure 6-23

Important! Your hands must be clean and sanitized before proceeding with the next steps.

13. Remove the splash guards from the doors.

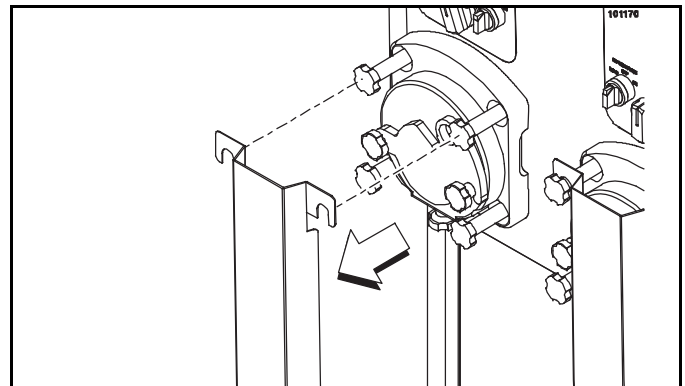

Figure 6-24

14. Remove the chute from the hopper.

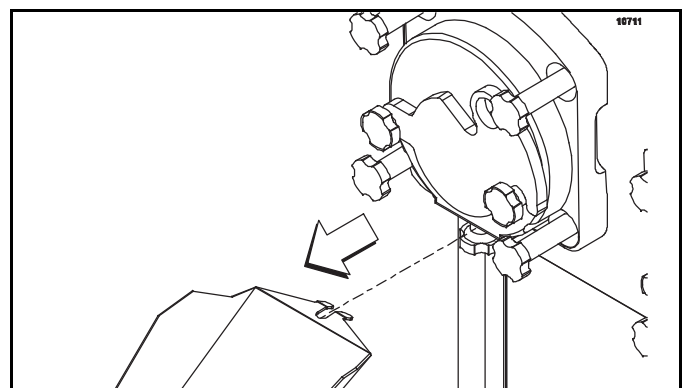

Figure 6-25

15. Install the feed tube assembly into the mix inlet hole located at the bottom of the hopper. Make sure the feed-tube is completely seated in the mix inlet hole.

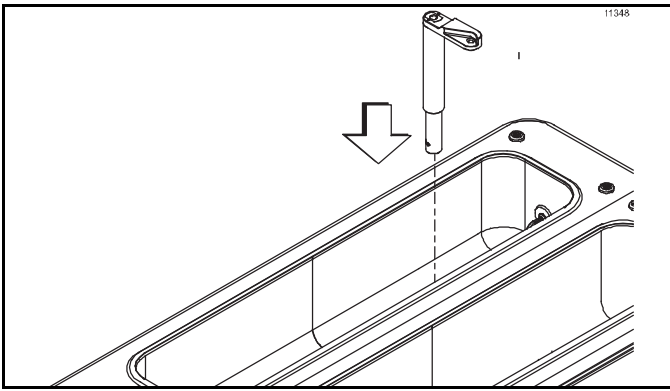

Figure 6-26

- Place one end of the flow control rod into the hole located on the feed tube. Place the other end of the rod into the hole on the front flow control lever.

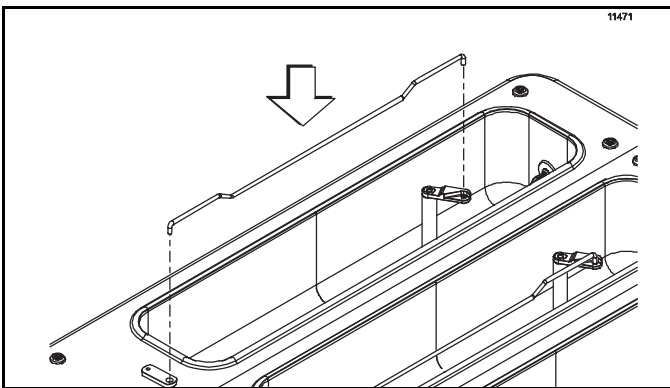

Figure 6-27

6

- Discard the sanitizer.
- Repeat steps 1 to 17 for the remaining freezing cylinders.

Priming

- IMPORTANT:** Verify that the flow adjustment knob is in the CLOSE position and the beater motor switch is in the OFF position. The draw arm plate must be closed.

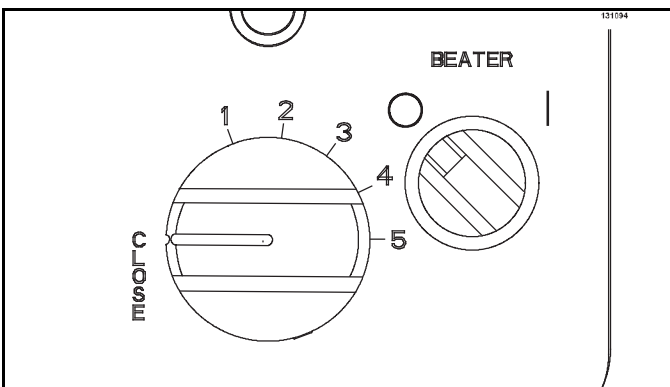

Figure 6-28

Note: The flow adjustment knob is used to adjust the flow of mix. Turning the adjustment knob clockwise increases the flow. A counterclockwise turn decreases the flow. Adjust the mix flow as needed to maintain proper product consistency.

- On the front half of the hoppers, install the hopper covers that have the raised lip.

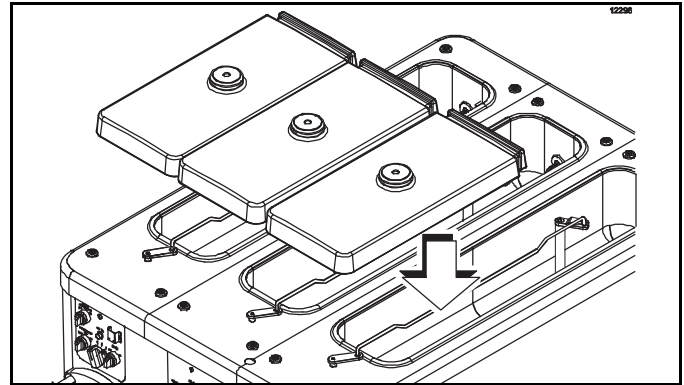

Figure 6-29

- Place the hopper refrigeration knob in the ON position and set the timer for 30 minutes.

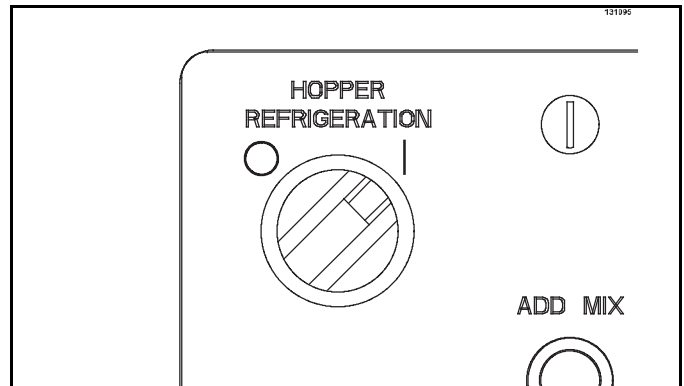

Figure 6-30

- After 30 minutes have expired, fill the hopper with fresh mix.

Note: Use only fresh mix when priming the freezer.

- On the back half of the hoppers, install the hopper covers that have the concave lip. For maximum capacity, the hopper should be full.

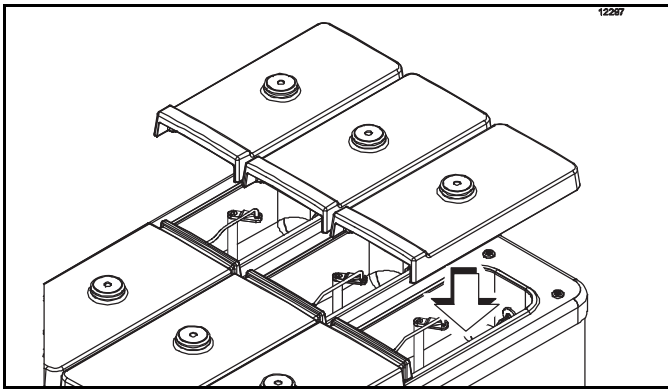

Figure 6-31

6. With the beater switch in the ON position and the draw arm plate open, turn the flow control valve to 3 for 3 seconds to force out any residual water/sanitizer.
7. Once the water/sanitizer are purged out from the barrel, close the draw arm plate.
8. Place the beater switch and the refrigeration switch in the ON position. Set the timer for 1 minute.

Note: The refrigeration switch will not activate unless the beater switch is on.

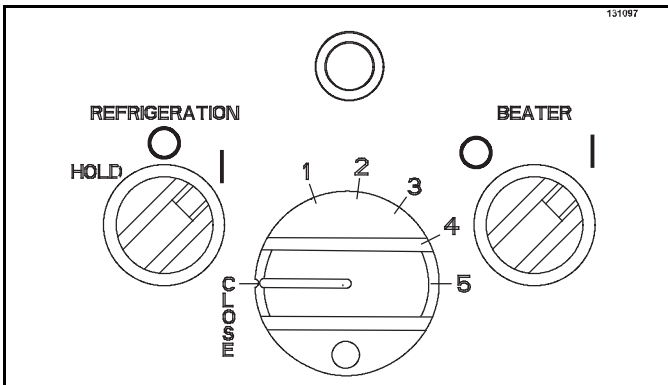

Figure 6-32

9. After 1 minute has expired, turn the flow adjustment knob to 1 and set the timer for 3 minutes.

Note: Whenever an adjustment is made, first turn the adjustment knob all the way to 5 and then back to the desired number.

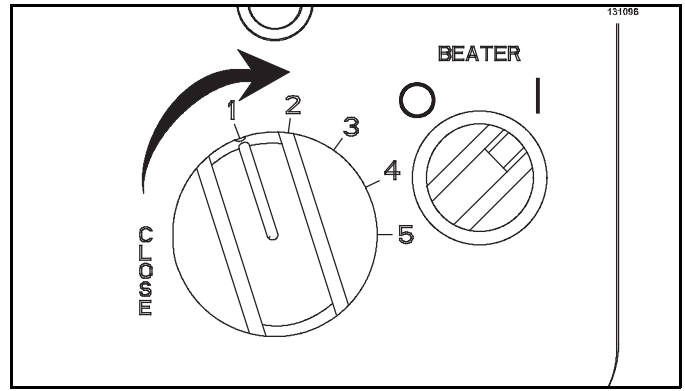

Figure 6-33

10. After 3 minutes have expired, open the draw arm plate. If the custard is too soft, close the draw arm plate and wait 1 minute. Repeat until the custard looks servable.

Note: The first couple inches of custard will force out any remaining sanitizing solution and should be discarded.

11. Close the draw arm plate. Using sanitized hands, install a sanitized product chute.

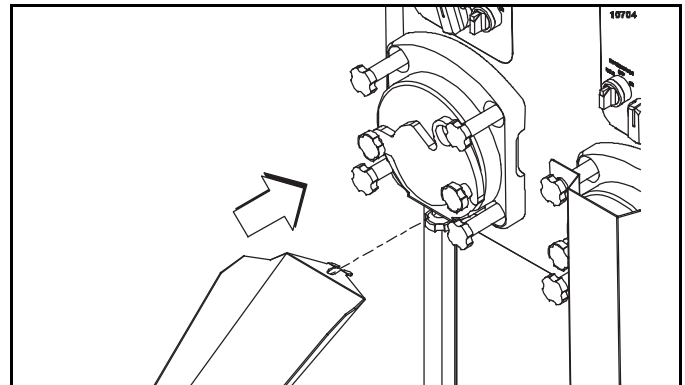

Figure 6-34

12. Open the draw arm plate.

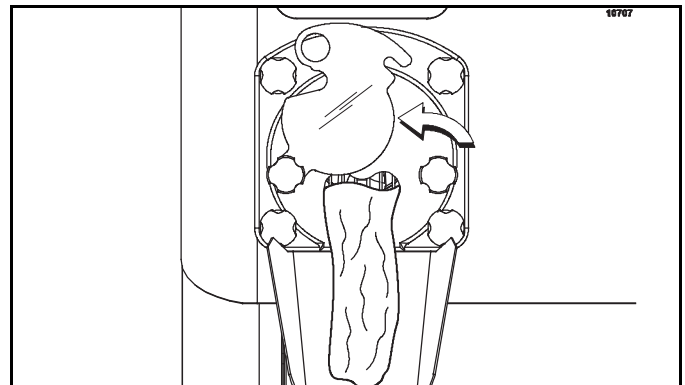

Figure 6-35

OPERATING PROCEDURES

Note: A chattering noise indicates that not enough mix is entering the freezing cylinder. It may be necessary to increase the flow of mix into the freezing cylinder. Increase the flow control knob only 1/2 a number at a time. It takes 3 to 5 minutes to see the results of the adjustment. (Whenever an adjustment is made, first turn the adjustment knob all the way to 5 and then back to the desired number.)

- Continue to run the frozen custard into the holding cabinet until the desired amount is obtained. Adjust the mix flow as needed to maintain proper product consistency. For maximum capacity, make sure the hopper is full and the flow is adjusted as high as possible within the acceptable product temperature range.

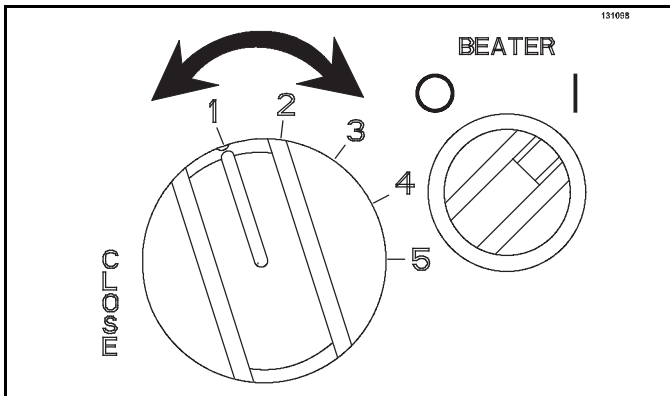

Figure 6-36

- When the desired amount is obtained and more custard will be made later, follow the "Hold Cycle During Operation" instructions starting on page 6-8.
- Repeat steps 1 to 14 for the remaining freezing cylinders.

Hold Cycle During Operation

- Place the flow adjustment knob in the CLOSE position. Set the timer for 1 minute.

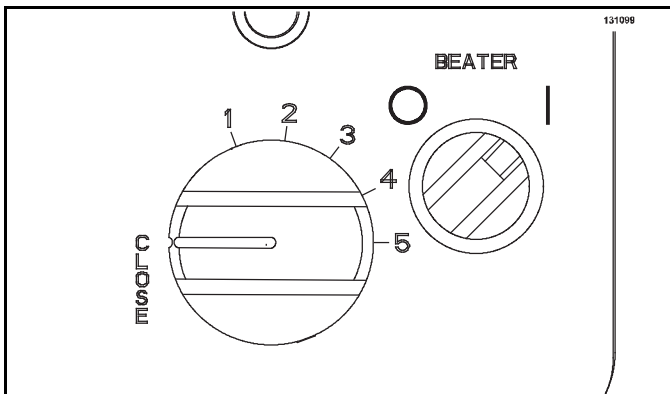

Figure 6-37

- After 1 minute has expired, place the refrigeration switch in the HOLD position for custard.

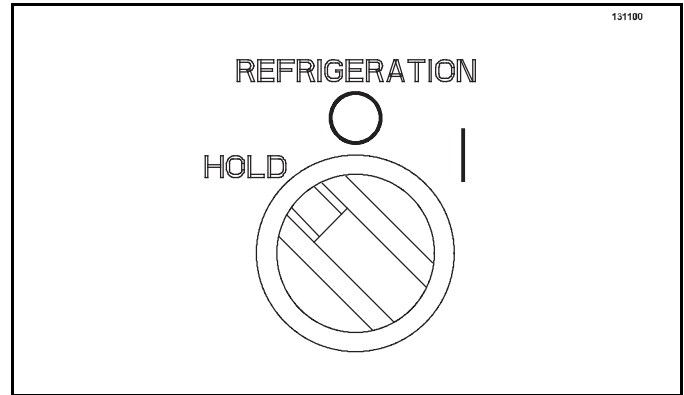

Figure 6-38

- When the frozen custard stops flowing (approximately 2 minutes), place the beater motor switch in the OFF position.

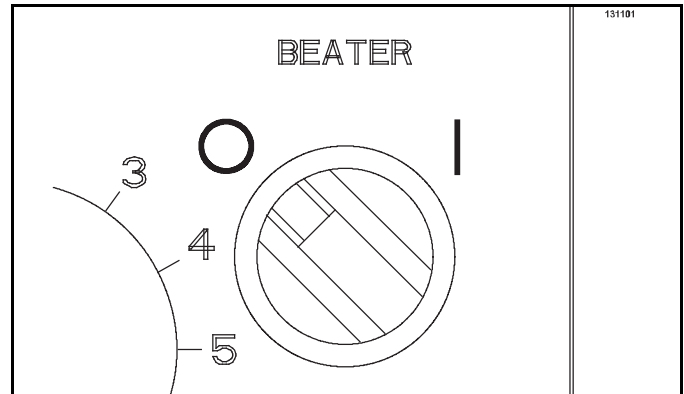

Figure 6-39

- Use the rake to remove as much custard from the product door as possible.

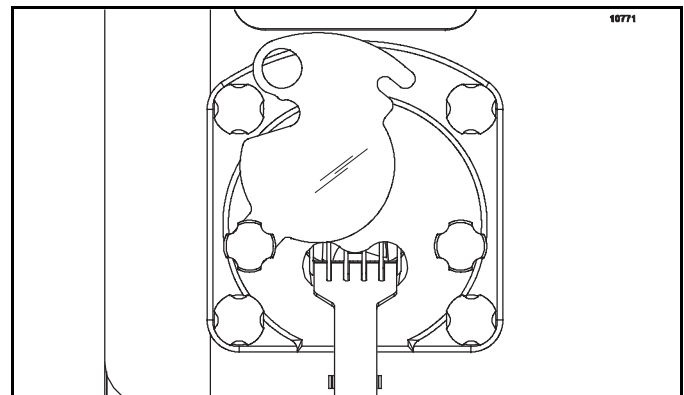

Figure 6-40

- Close the draw arm plate. Make sure the left stud nut is secured, and then the right stud nut.

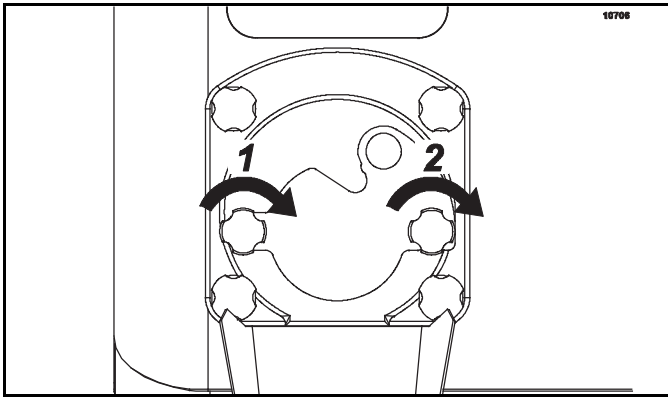

Figure 6-41

- Remove the custard chute and take it to the sink for cleaning and sanitizing.

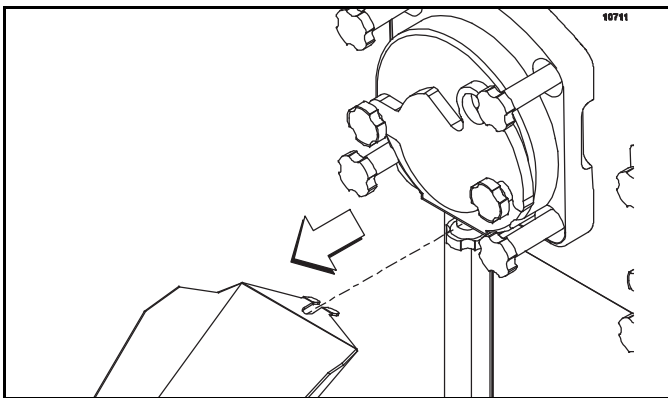

Figure 6-42

- Close the dipping cabinet cover.
- Prepare a squeeze bottle of approved 100 PPM sanitizing solution. Squeeze the sanitizing solution around the draw arm plate and stud nuts to remove any left-over product. If necessary, brush clean the area with the door spout brush and rinse with the sanitizing solution.

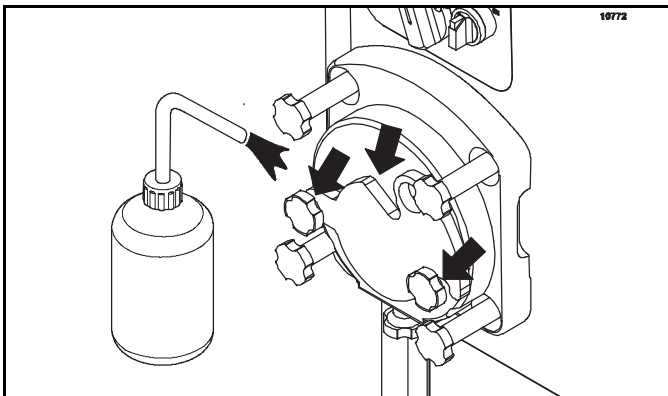

Figure 6-43

- Repeat steps 1 to 8 for the remaining freezing cylinders.

Resuming Production During Operation

- Place the beater switch in the ON position.

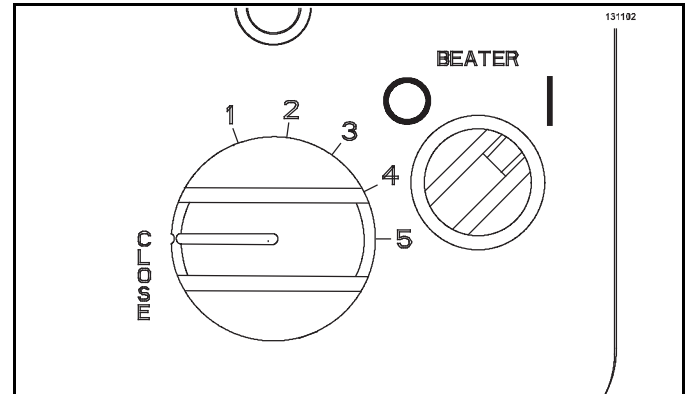

Figure 6-44

- Place the refrigeration switch in the ON position.

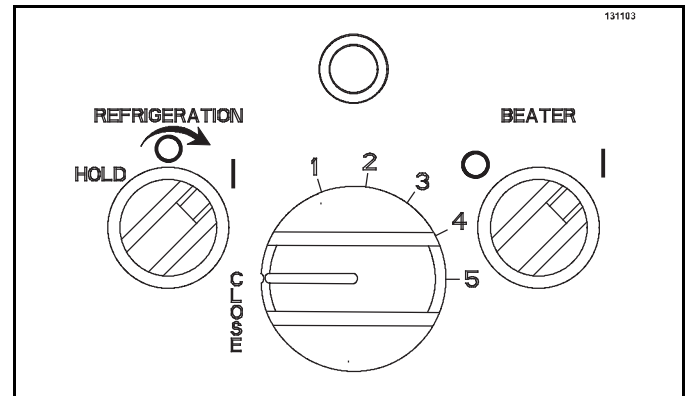

Figure 6-45

- Set the timer for 1 minute. After the minute expires, open the flow control assembly to 1 and set the timer for 3 minutes.

Note: Whenever an adjustment is made, first turn the adjustment knob all the way to 5 and then back to the desired number.

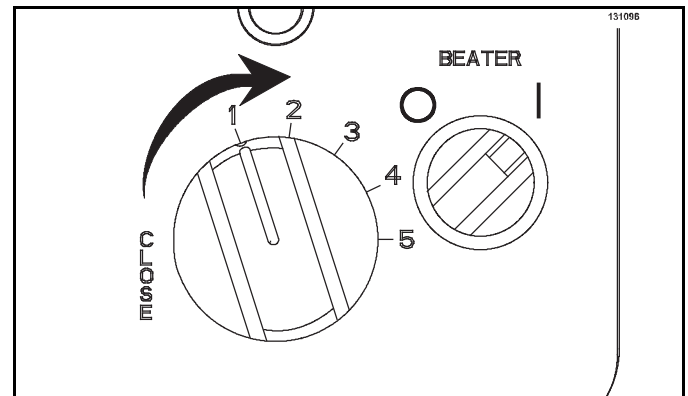

Figure 6-46

OPERATING PROCEDURES

- After 3 minutes have expired, open the draw arm plate. If the custard is too soft, close the draw arm plate and wait 1 minute. Repeat as necessary.

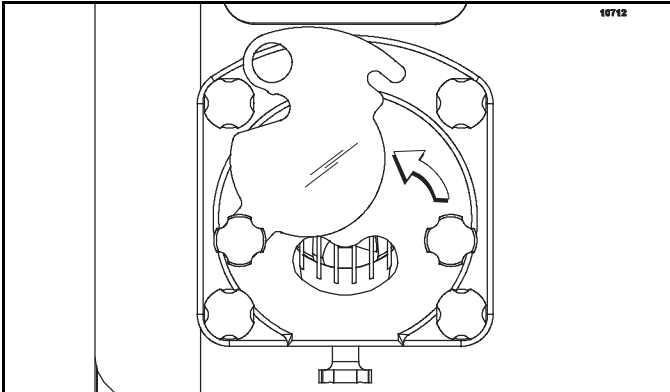

Figure 6-47

- When custard appears, adjust the flow adjustment knob to gain the desired custard texture. Turn the flow adjustment knob clockwise if the product is too firm and counterclockwise if the product is too soft.

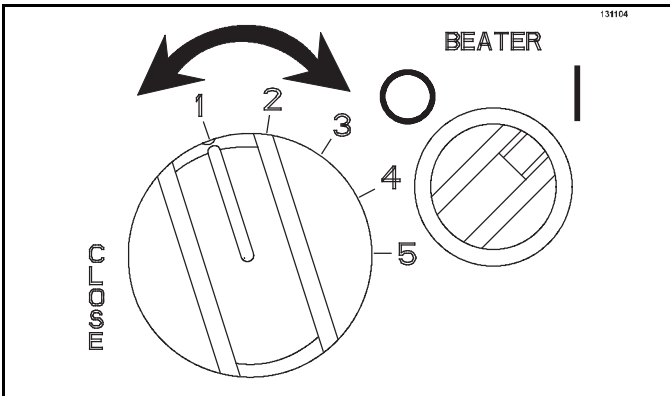

Figure 6-48

- When the product looks servable, close the draw arm plate. Using sanitized hands, install a sanitized custard chute.

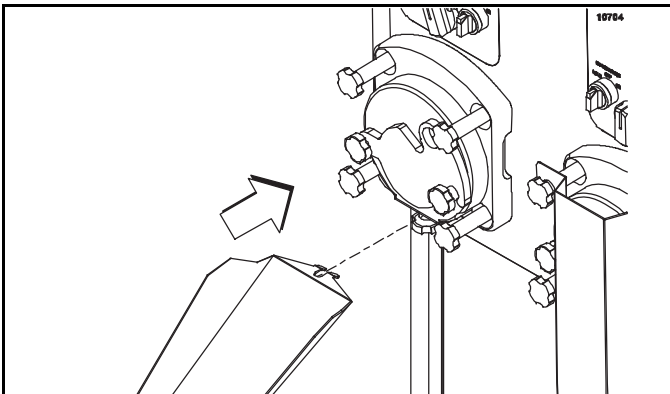

Figure 6-49

- Open the draw arm plate. Continue to run the frozen custard into the holding cabinet until the desired amount is obtained. Adjust the mix flow as needed to maintain proper product consistency. When the desired amount is obtained and more custard will be made later, follow the "Hold Cycle During Operation" instructions starting on page 6-8.

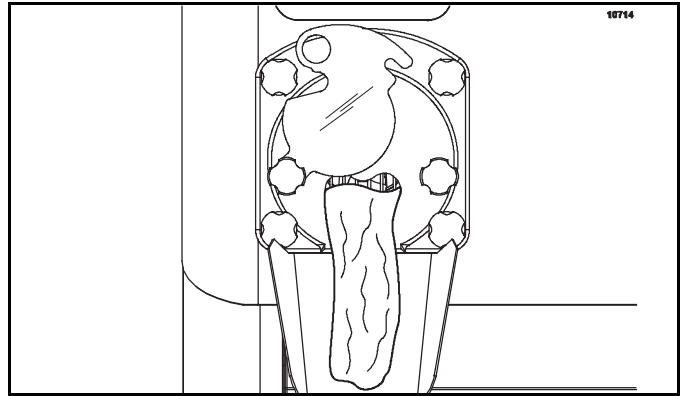

Figure 6-50

Preparing for Shutdown

Perform the following procedures to remove the remaining custard in the freezing cylinder when there is mix in the hopper.

- Place the refrigeration switch in the OFF position.

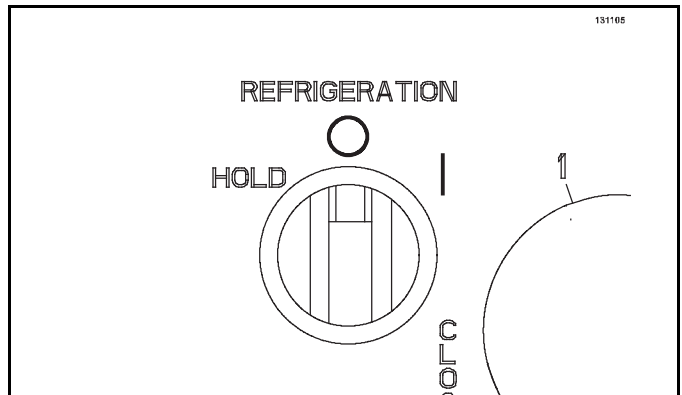

Figure 6-51

- Set the timer for 20 minutes. This allows the freezing cylinder enough time to warm before removing the remaining custard.
- Place the beater switch in the ON position.

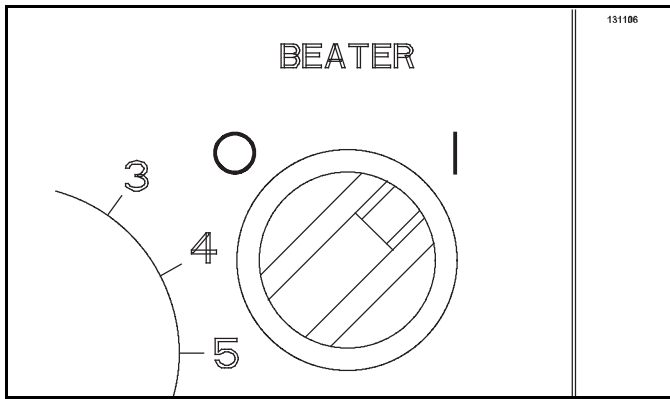

Figure 6-52

4. Open the dipping cabinet cover. Close the draw arm plate. Using sanitized hands, install a sanitized custard chute.

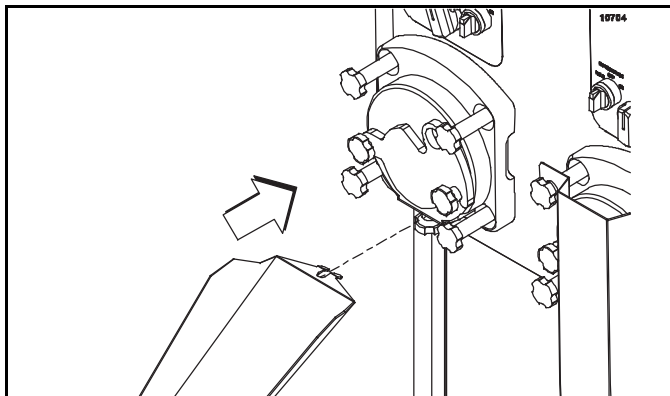

Figure 6-53

5. Open the draw arm plate and turn the flow adjustment knob to 5. Run the remaining mix through the freezing cylinder and properly dispose of the mix.

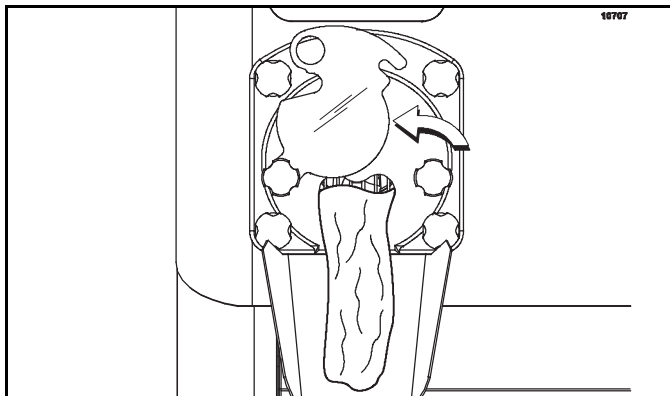

Figure 6-54

Note: If local health codes permit the use of rerun, place a sanitized, NSF-approved rerun container beneath the opening of the front plate and run the remaining mix into the container. See page 7-1 for instructions regarding the proper use of rerun.

6. After all the custard has drained from the hopper, remove the hopper cover, the flow control rod, and the feed tube.

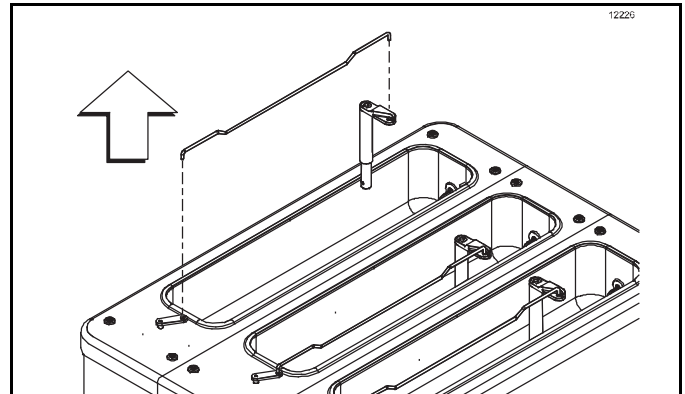

Figure 6-55

7. Repeat steps 1 to 6 for the remaining freezing cylinders.

Rinsing

1. Place the hopper refrigeration switch in the OFF position.

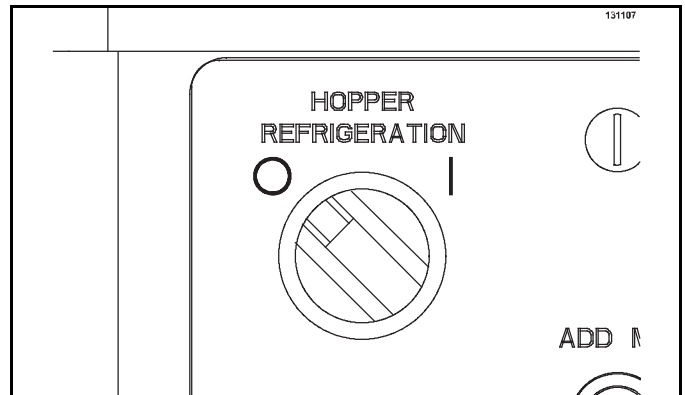

Figure 6-56

2. Make sure the refrigeration switch is in the OFF position.

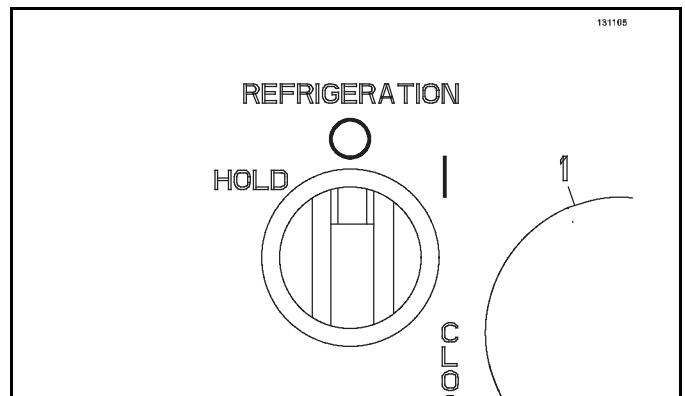

Figure 6-57

OPERATING PROCEDURES

- Close the draw arm plate and remove the product chute.

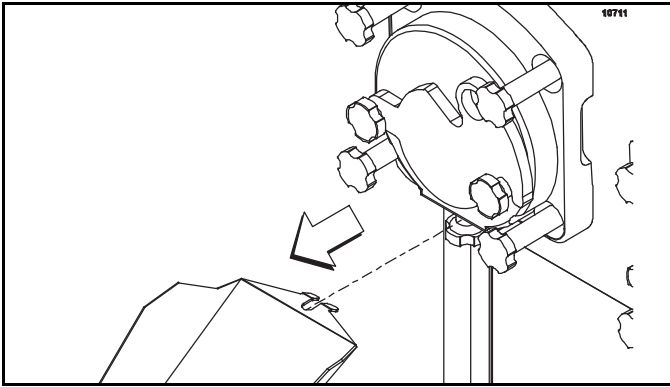

Figure 6-58

- Install the splash guard.

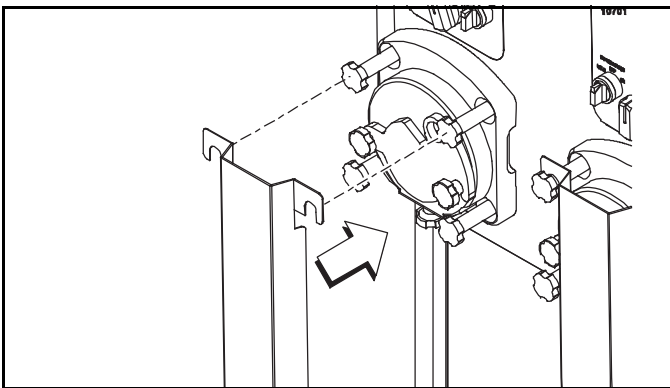

Figure 6-59

- With a pail beneath the draw arm plate, pour 4 gal. (15 L) of cool, clean water into the hopper.

Note: Use the faucet if the machine is equipped with one.

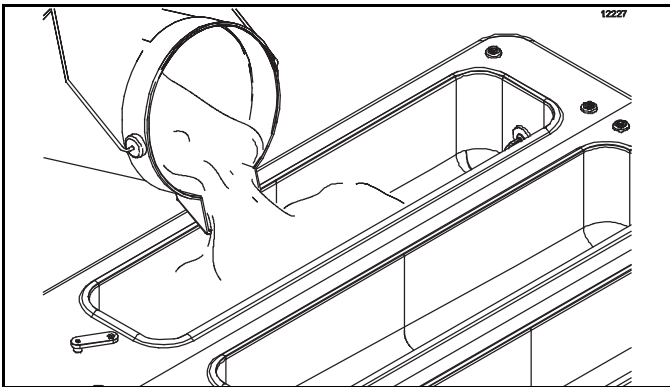

Figure 6-60

- With the brushes provided, scrub the mix hopper.

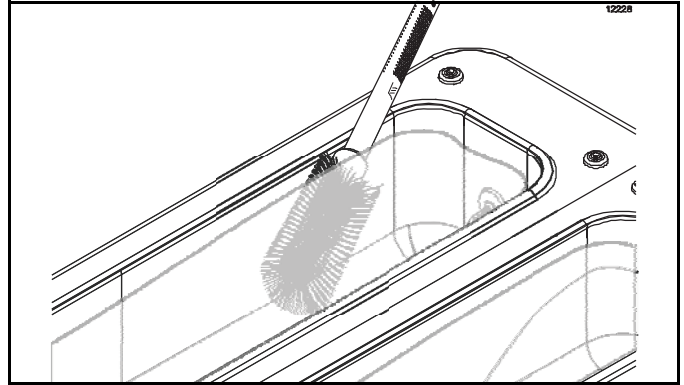

Figure 6-61

- Place the beater switch in the ON position.

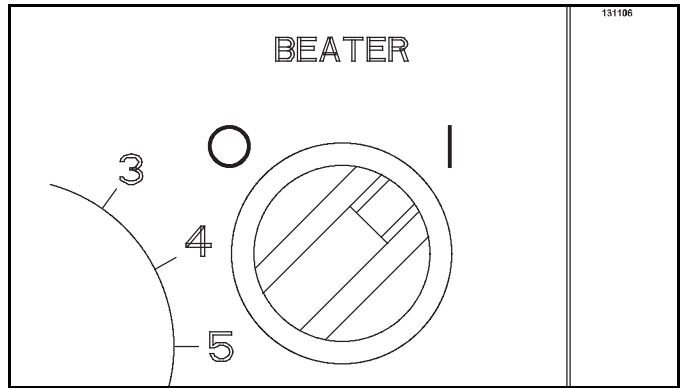

Figure 6-62

- Open the draw plate and drain the rinse water from the freezing cylinder.

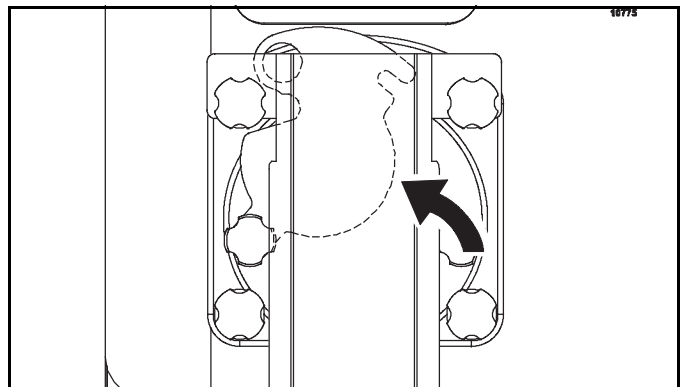

Figure 6-63

- Repeat this procedure until all mix residue is gone and the water is clear.

- Place the beater switch in the OFF position.

6

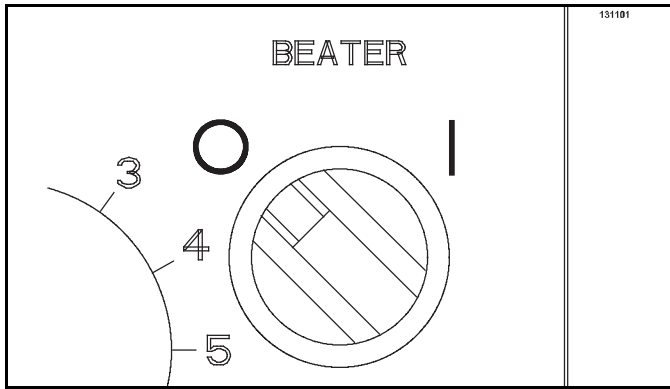

Figure 6-64

11. Repeat steps 1 to 10 for the remaining freezing cylinders.

Cleaning

Important! Failure to follow these cleaning procedures may result in bacterial contamination of the frozen custard product.



1. Make sure the refrigeration switch is in the OFF position.

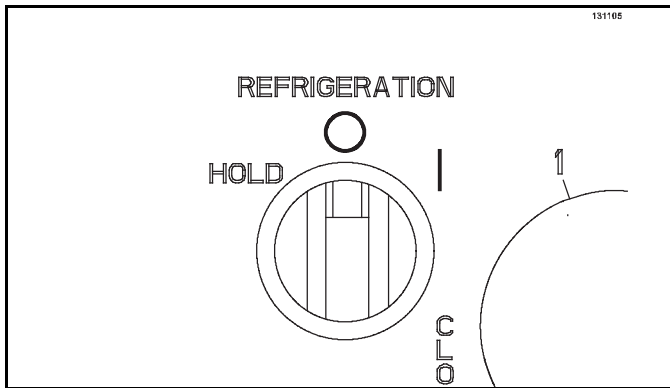

Figure 6-65

2. Close the draw arm plate.

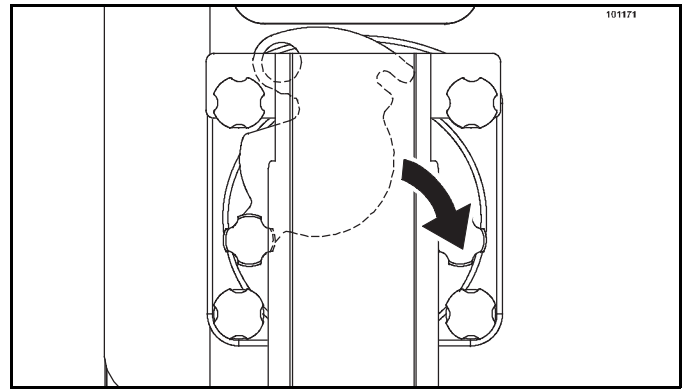

Figure 6-66

3. Using lukewarm water, prepare an approved 100 PPM sanitizing solution (examples: 5 gal. [19 L] of Kay-5® or 4 gal. [15 L] of Stera-Sheen®).

Important! Use warm water and follow the manufacturer's specifications.

4. Pour the cleaning solution into the hopper. Brush clean the sides and bottom of the hopper.

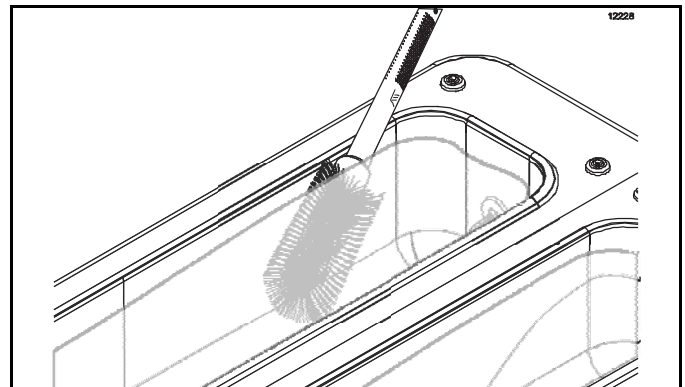

Figure 6-67

5. Place the beater switch in the ON position. Set the timer for 5 minutes.

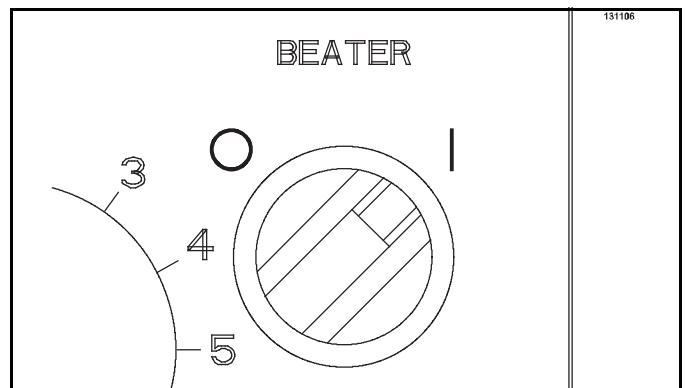

Figure 6-68

6. After 5 minutes has elapsed, open the draw arm plate and drain all the solution from the freezing cylinder.

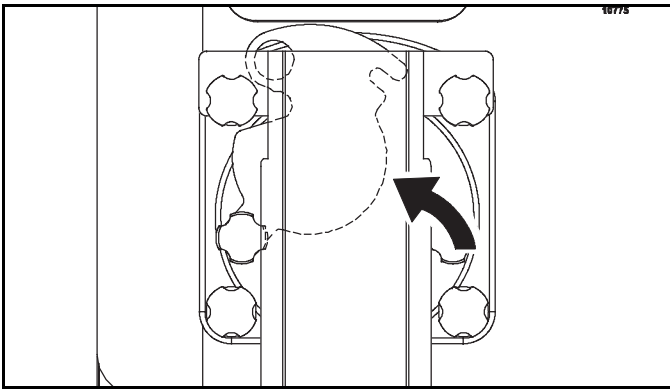
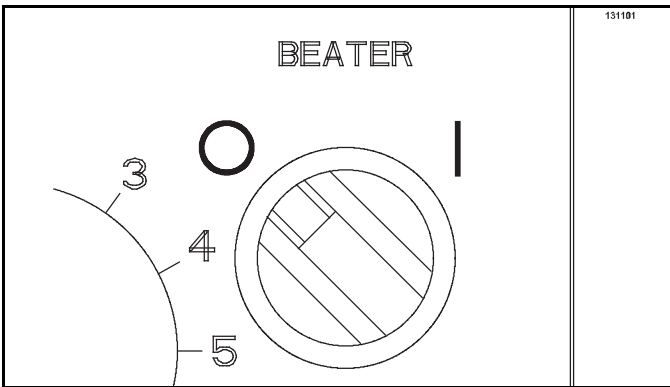

Figure 6-69

7. Place the beater switch in the OFF position.



8. Repeat steps 1 to 7 for each freezing cylinder.

6 Disassembly



WARNING! Make sure the power switch is in the OFF position. Failure to follow this instruction may result in severe personal injury from hazardous moving parts.

1. Remove the door assembly.

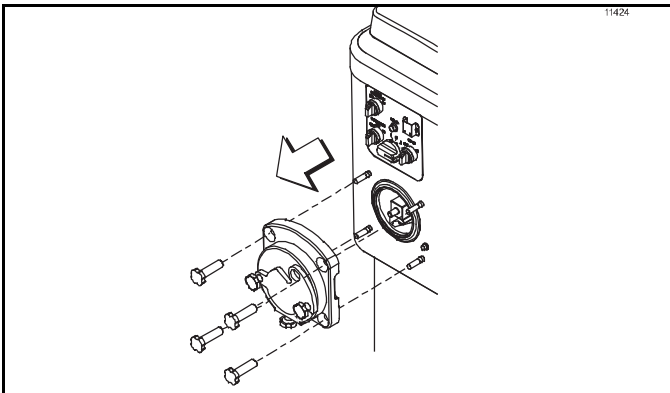

Figure 6-70

2. Disassemble the door assembly. Remove the gasket from the product door.

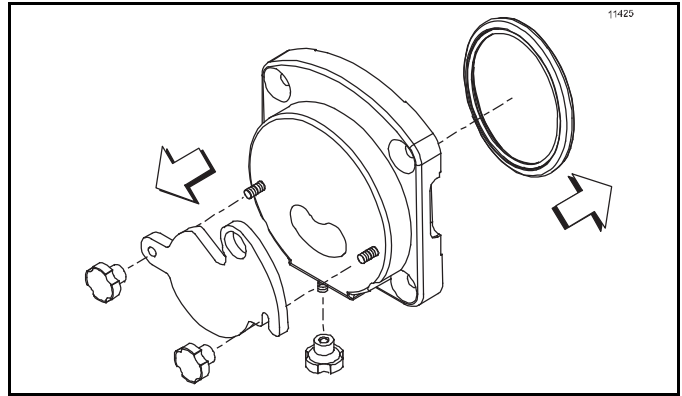

Figure 6-71

3. Remove the front bearing from the door or beater shaft.

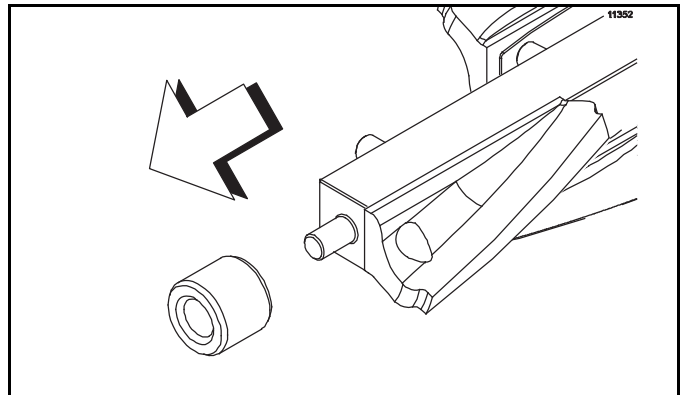

Figure 6-72

4. While removing the beater shaft, take each blade and leaf spring off and place them in a container for cleaning.

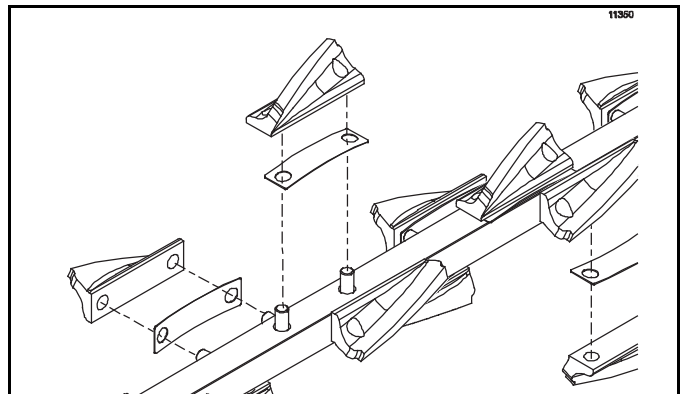

Figure 6-73

5. Remove the rear seal from the beater shaft. Use a single-use towel to remove the lubricant from the seal before taking it to the sink for cleaning.

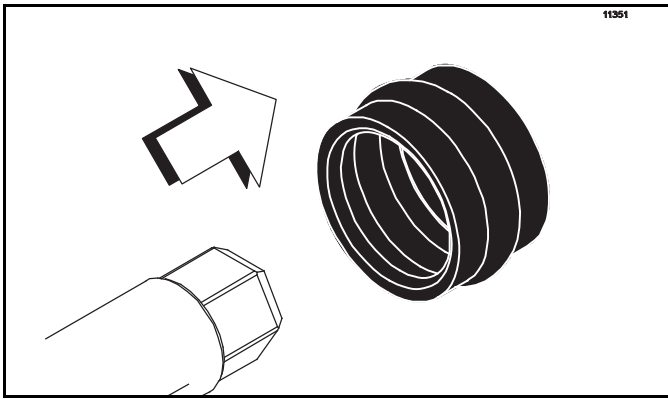

Figure 6-74

Note: If the rear seal remains in the drive coupling at the back of the machine, instead of coming out with the beater shaft, perform the following:

- Reinstall three blades and leaf springs on the beater shaft.
 - Slide the beater shaft back into the freezing cylinder until the hex end is firmly engaged in the drive coupling.
 - Remove the beater shaft by pulling it straight out.
 - Repeat as necessary until the rear seal is removed.
6. Remove the hopper covers, the feed tube, and the flow control rod.

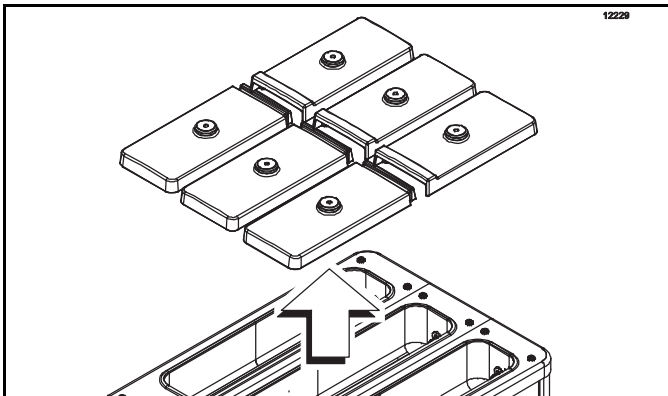

Figure 6-75

7. Take all the parts to the sink for complete disassembly and brush cleaning.
8. **Repeat steps 1 to 7** for each freezing cylinder.

Brush Cleaning

Important! Failure to follow these cleaning procedures may result in bacterial contamination of the frozen custard product.



1. Prepare a sink with an approved cleaning solution (examples: Kay-5[®] or Stera-Sheen[®]).

Important! Use warm water and follow the manufacturer's specifications.

If another approved cleaner is used, dilute it according to the label instructions.

Important! Follow the label directions. Too strong of a solution can cause parts damage, while too mild of a solution will not provide adequate cleaning.

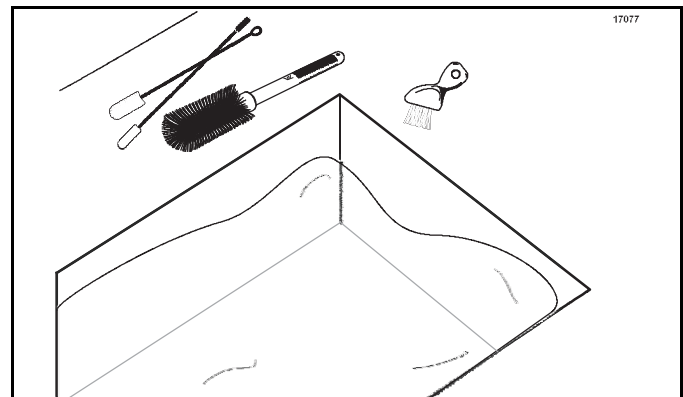

Figure 6-76

Make sure all brushes provided with the freezer are available for brush cleaning.

2. Thoroughly brush clean all disassembled parts in the cleaning solution, making sure all lubricant and mix film is removed.

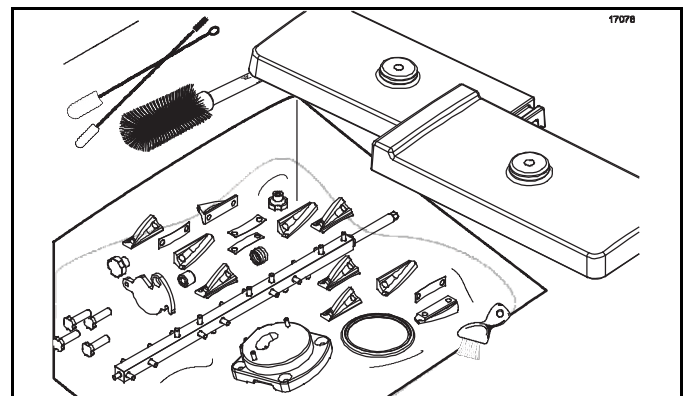

Figure 6-77

OPERATING PROCEDURES

3. Use the double-ended brush to clean the inside of the feed tubes.

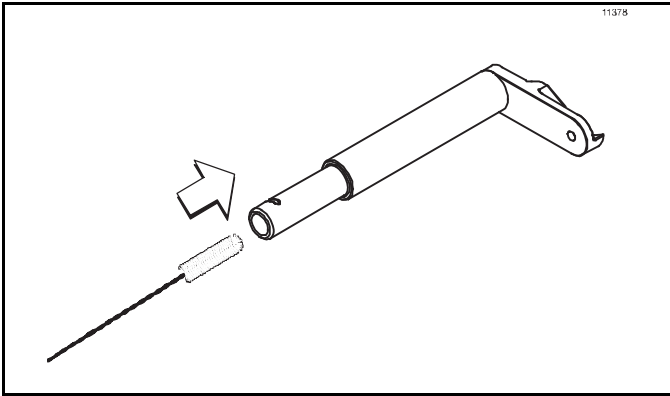

Figure 6-78

4. Return to the freezer with a small amount of cleaning solution. Using the draw valve brush (1 in. x 2 in. x 17 in.), brush clean the mix inlet hole in each mix hopper.

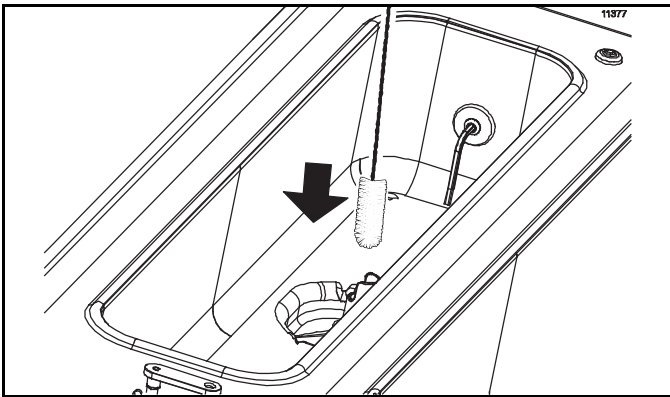

Figure 6-79

5. Using the brush with the long black tip, brush clean the rear-shell bearing at the back of each freezing cylinder.

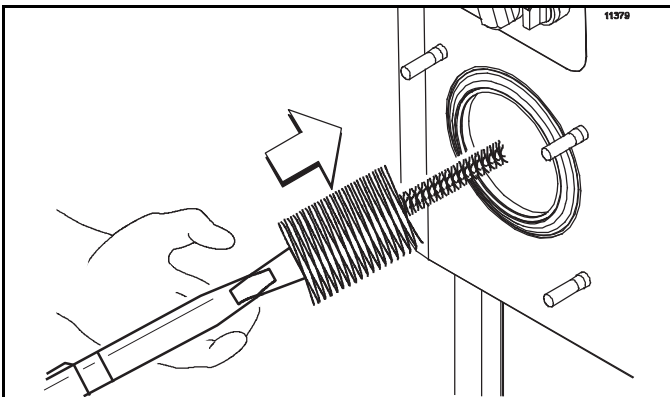

Figure 6-80

6. Using the long, white brush, brush clean each freezing cylinder.

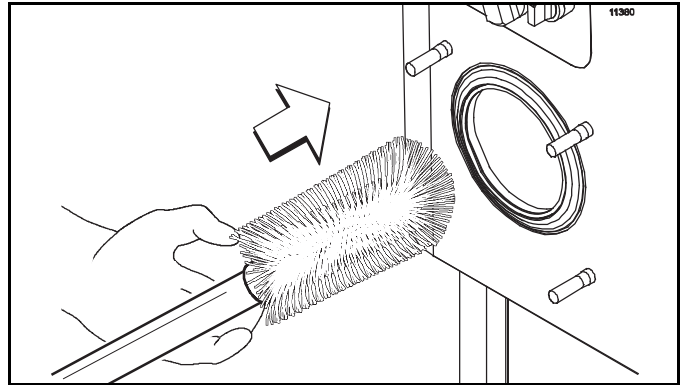

Figure 6-81

7. Prepare a sink with an approved sanitizing solution (examples: Kay-5® or Stera-Sheen®).

Important! Use warm water and follow the manufacturer's specifications.

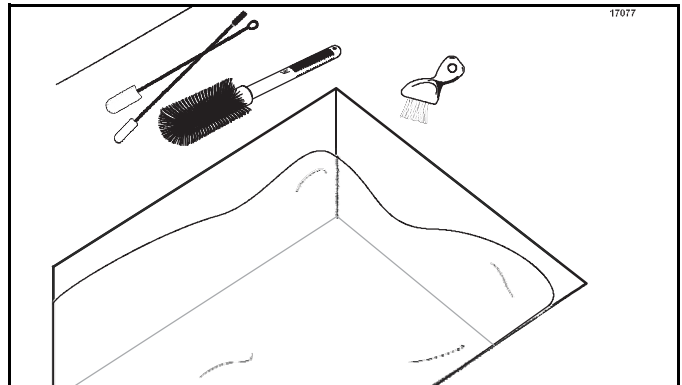

Figure 6-82

8. Repeat step 2 using the sanitizing solution.
9. Place all cleaned parts on a clean, dry surface to air-dry overnight.
10. Empty, clean, and reinstall the rear drip pan.

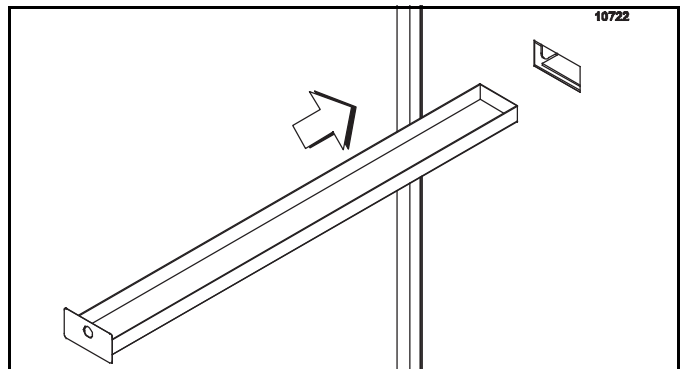

Figure 6-83

11. Wipe clean all exterior surfaces of the machine with a clean, sanitized towel.

During Cleaning and Sanitizing



ALWAYS FOLLOW LOCAL HEALTH CODES.

Cleaning and sanitizing schedules are governed by federal, state, or local regulatory agencies, and must be followed accordingly. If the machine has a Standby mode, it must not be used instead of proper cleaning and sanitizing procedures and frequencies set forth by the ruling health authority. The following checkpoints should be stressed during the cleaning and sanitizing operations.



IMPORTANT! *Cleaning and sanitizing must be performed daily.*

Troubleshooting Bacterial Count

- Thoroughly clean and sanitize the machine regularly, including complete disassembly and brush cleaning.
 - Use all brushes supplied for thorough cleaning. The brushes are specially designed to reach all mix passageways.
 - Use the white bristle brush to clean the mix inlet hole which extends from the mix hopper down to the rear of the freezing cylinder.
 - Use the black bristle brush to thoroughly clean the rear shell bearing located at the rear of the freezing cylinder. Use a generous amount of cleaning solution on the brush.
 - IF LOCAL HEALTH CODES PERMIT THE USE OF RERUN, make sure the mix rerun is stored in a sanitized, covered stainless-steel container and used the following day. **Do not** prime the machine with rerun. When using rerun, skim off the foam and discard. Mix the rerun with **fresh** mix in a ratio of 50:50 during the day's operation.
- On a designated day of the week, run the mix as low as feasible and discard it after closing. This will break the rerun cycle and reduce the possibility of high bacteria and coliform counts.
 - Properly prepare the cleaning and sanitizing solutions. Read and follow the label directions carefully. Too **strong** of a solution may damage the parts and too **weak** of a solution will not do an adequate job of cleaning or sanitizing.
 - The temperature of the mix in the mix hopper and walk-in cooler should be below 40°F (4.4°C).

Regular Maintenance Checks

- Replace scraper blades that are nicked or damaged. Before installing the beater assembly, make sure the scraper blades are properly attached to the beater shaft.
- Check the rear-shell bearing for signs of wear (excessive mix leakage in rear drip pan) and make sure it is properly cleaned.
- Using a long brush and a cloth towel, keep the rear-shell bearing and the female hex drive socket clean and free of lubricant and mix deposits.
- Dispose of O-rings and seals if they are worn, torn, or fit too loosely, and replace with new ones.
- Follow all lubricating procedures as outlined in "Assembly" on page 6-1.
- If your machine is air-cooled, check the condenser for dirt and lint accumulation. Dirty condensers will reduce the efficiency and capacity of the machine. Condensers should be cleaned monthly with a soft brush. Never use screwdrivers or other metal probes to clean between the fins.

Note: *For machines equipped with an air filter, it will be necessary to vacuum the filters monthly.*



WARNING! Always disconnect electrical

OPERATOR CHECKLIST

power prior to cleaning the condenser. Failure to follow this instruction may result in electrocution.

- If your machine is water-cooled, check the water lines for kinks or leaks. Kinks can occur when the machine is moved back and forth for cleaning or maintenance purposes. Deteriorated or cracked water lines should be replaced only by an authorized Taylor distributor.

Winter Storage

If the place of business is to be closed during the winter months, it is important to protect the freezer by following certain precautions, particularly if the building is subject to freezing conditions.

Disconnect the freezer from the main power source to prevent possible electrical damage.

On water-cooled freezers, disconnect the water supply. Relieve pressure on the spring in the water valve. Use air pressure on the outlet side to blow out any water remaining in the condenser. **This is extremely important.** Failure to follow this procedure may cause severe and costly damage to the refrigeration system.

Your local Taylor distributor can perform this winter storage service for you.

Wrap detachable parts of the freezer (such as dasher, blades, dasher shaft, and freezer door) and place them in a protected dry place. Rubber trim parts and gaskets can be protected by wrapping them with moisture-proof paper. All parts should be thoroughly cleaned of dried mix or lubrication, which can attract mice and other vermin.

It is recommended that an authorized service technician perform winter storage draining to make sure all water has been removed. This will guard against freezing and rupturing of the components.

Table 8-1

Problem	Probable Cause	Remedy	Page Ref.
1. Product is too stiff.	a. Flow regulator is set too low.	a. Adjust the flow regulator setting	6-6
2. The scraper blades make a chattering noise.	a. Flow rate is too slow.	a. Adjust the flow rate.	6-8
3. Product is too soft.	a. Flow rate is too fast. b. There is a problem with the refrigeration system.	a. Adjust the flow rate. b. Call an authorized service technician.	6-6 - - -
4. The mix low indicator is illuminated.	a. Inadequate level of mix in the mix hopper. b. Bad electrical connection.	a. Fill the mix hopper with mix. b. Call an authorized service technician.	6-6 - - -
5. The mix low indicator is illuminated and the product is too stiff.	a. The level of mix in the mix hopper is inadequate and the flow rate is too slow.	a. Fill the hopper with mix if further production is required. If no further production is required, open the flow control all the way and place the refrigeration switch in the OFF position.	6-6
6. Beater motor won't start.	a. The beater motor overload has tripped. b. The power switch is in the OFF position. c. The beater motor switch is in the OFF position. d. The circuit breaker is off or the fuse is blown.	a. Turn the machine off. Press the reset button and restart the machine. b. Place the power switch in the ON position. c. Place the beater motor switch in the ON position. d. Turn the breaker on, or replace the fuse.	- - - - - - - - - - - -

Section 9

Parts Replacement Schedule

Table 9-1

Part Description	Every 3 Months	Every 6 Months	Annually	Every 3 years
Brush-Dbf End-Pump and Feed		Inspect and replace if necessary.	Minimum	
Brush-Draw Valve 1" OD x 2" x17"		Inspect and replace if necessary.	Minimum	
Brush-Barrel		Inspect and replace if necessary.	Minimum	
Brush-Rear BRG		Inspect and replace if necessary.	Minimum	
Brush-Mix Pump Body 3" x 7"		Inspect and replace if necessary.	Minimum	
Brush-End-Door-Spout-SS		Inspect and replace if necessary.	Minimum	
Gasket-Door	X			
Bearing-Door-Front	X			
Seal-Drive Shaft	X			
Blade-Scraper 30 Pitch				X
Blade-Scraper-Rear 30 Pitch				X
Spring-Beater Blade				X

TAYLOR COMPANY LIMITED WARRANTY ON FREEZERS

Taylor Company is pleased to provide this limited warranty on new Taylor-branded freezer equipment available from Taylor to the market generally (the "Product") to the original purchaser only.

LIMITED WARRANTY

Taylor warrants the Product against failure due to defect in materials or workmanship under normal use and service as follows. All warranty periods begin on the date of original Product installation. If a part fails due to defect during the applicable warranty period, Taylor, through an authorized Taylor distributor or service agency, will provide a new or remanufactured part, at Taylor's option, to replace the failed defective part at no charge for the part. Except as otherwise stated herein, these are Taylor's exclusive obligations under this limited warranty for a Product failure. This limited warranty is subject to all provisions, conditions, limitations, and exclusions listed below and on the reverse (if any) of this document.

Table 10-1

Product	Part	Limited Warranty Period
Soft Serve	Insulated Shell Assembly	Five (5) Years
Frozen Yogurt Shakes	Refrigeration Compressor (except service valve)	Five (5) Years
Smoothies	Beater Motors	Two (2) Years
Frozen Beverage	Beater Drive Gear	Two (2) Years
Batch Desserts	Printed circuit boards and Softech controls beginning with serial number H8024200	Two (2) Years
	Parts Not Otherwise Listed in This Table or Excluded Below	One (1) Years

LIMITED WARRANTY CONDITIONS

1. If the date of original installation of the Product cannot be verified, then the limited warranty period begins ninety (90) days from the date of Product manufacture (as indicated by the Product serial number). Proof of purchase may be required at time of service.
2. This limited warranty is valid only if the Product is installed and all required service work on the Product is performed by a Taylor-authorized distributor or service agency, and only if genuine, new Taylor parts are used.
3. Installation, use, care, and maintenance must be normal and in accordance with all instructions contained in the Taylor Operator's Manual.
4. Defective parts must be returned to the Taylor-authorized distributor or service agency for credit.
5. The use of any refrigerant other than that specified on the Product's data label will void this limited warranty.

LIMITED WARRANTY ON EQUIPMENT

LIMITED WARRANTY EXCEPTIONS

This limited warranty does **not** cover:

1. Labor or other costs incurred for diagnosing, repairing, removing, installing, shipping, servicing, or handling of defective parts, replacement parts, or new Products.
2. Normal maintenance, cleaning, and lubrication as outlined in the Taylor Operator's Manual, including cleaning of condensers.
3. Replacement of wear items designated as Class "000" parts in the Taylor Operator's Manual.
4. External hoses, electrical power supplies, and machine grounding.
5. Parts not supplied or designated by Taylor, or damages resulting from their use.
6. Return trips or waiting time required because a service technician is prevented from beginning warranty service work promptly upon arrival.
7. Failure, damage, or repairs due to faulty installation, misapplication, abuse, no or improper servicing, unauthorized alteration, or improper operation or use as indicated in the Taylor Operator's Manual, including but not limited to the failure to use proper assembly and cleaning techniques, tools, or approved cleaning supplies.
8. Failure, damage, or repairs due to theft, vandalism, wind, rain, flood, high water, water, lightning, earthquake, or any other natural disaster, fire, corrosive environments, insect or rodent infestation, or other casualty, accident, or condition beyond the reasonable control of Taylor; operation above or below the electrical or water supply specification of the Product; components repaired or altered in any way so as to, in the judgment of the Manufacturer, adversely affect performance, or normal wear or deterioration.
9. Any Product purchased over the Internet.
10. Failure to start due to voltage conditions, blown fuses, open circuit breakers, or damages due to the inadequacy or interruption of electrical service.
11. Electricity or fuel costs, or increases in electricity or fuel costs for any reason whatsoever.
12. Damages resulting from the use of any refrigerant other than that specified on the Product's data label will void this limited warranty.
13. Any cost to replace, refill, or dispose of refrigerant, including the cost of refrigerant.
14. **ANY SPECIAL, INDIRECT, OR CONSEQUENTIAL PROPERTY OR COMMERCIAL DAMAGE OF ANY NATURE WHATSOEVER.** Some jurisdictions do not allow the exclusion of incidental or consequential damages, so this limitation may not apply to you.

This limited warranty gives you specific legal rights, and you may also have other rights that vary from jurisdiction to jurisdiction.

LIMITATION OF WARRANTY

THIS LIMITED WARRANTY IS EXCLUSIVE AND IS IN LIEU OF ALL OTHER WARRANTIES, CONDITIONS, AND/OR REMEDIES UNDER THE LAW, INCLUDING ANY IMPLIED WARRANTIES OR CONDITIONS OF MERCHANTABILITY OR FITNESS FOR A PARTICULAR PURPOSE. THE ORIGINAL OWNER'S SOLE REMEDY WITH RESPECT TO ANY PRODUCTS SHALL BE REPAIR OR REPLACEMENT OF DEFECTIVE COMPONENTS UNDER THE TERMS OF THIS LIMITED WARRANTY. ALL RIGHTS TO CONSEQUENTIAL OR INCIDENTAL DAMAGES (INCLUDING CLAIMS FOR LOST SALES, LOST PROFITS, PRODUCT LOSS, PROPERTY DAMAGES, OR SERVICE EXPENSES) ARE EXPRESSLY EXCLUDED. THE EXPRESS WARRANTIES MADE IN THIS LIMITED WARRANTY MAY NOT BE ALTERED, ENLARGED, OR CHANGED BY ANY DISTRIBUTOR, DEALER, OR OTHER PERSON, WHATSOEVER.

LEGAL REMEDIES

The owner **must** notify Taylor in writing by certified or registered letter to the following address, of any defect or complaint with the Product, stating the defect or complaint and a specific request for repair, replacement, or other correction of the Product under warranty, mailed at least thirty (30) days before pursuing any legal rights or remedies.

Taylor Company
750 N. Blackhawk Blvd.
Rockton, IL 61072, U.S.A.

TAYLOR COMPANY LIMITED WARRANTY ON TAYLOR GENUINE PARTS

Taylor Company, is pleased to provide this limited warranty on new Taylor genuine replacement components and parts available from Taylor to the market generally (the “Parts”) to the original purchaser only.

LIMITED WARRANTY

Taylor warrants the Parts against failure due to defect in materials or workmanship under normal use and service as follows. All warranty periods begin on the date of original installation of the Part in the Taylor unit. If a Part fails due to defect during the applicable warranty period, Taylor, through an authorized Taylor distributor or service agency, will provide a new or remanufactured Part, at Taylor’s option, to replace the failed defective Part at no charge for the Part. Except as otherwise stated herein, these are Taylor’s exclusive obligations under this limited warranty for a Part failure. This limited warranty is subject to all provisions, conditions, limitations, and exclusions listed below and on the reverse (if any) of this document.

Table 11-1

Parts Warranty Class Code or Part	Limited Warranty Period
Class 103 Parts ¹	Three (3) Months
Class 212 Parts ²	Twelve (12) Months
Class 512 Parts	Twelve (12) Months
Class 000 Parts	No Warranty

LIMITED WARRANTY CONDITIONS

1. If the date of original installation of the Part cannot be otherwise verified, proof of purchase may be required at time of service.
2. This limited warranty is valid only if the Part is installed and all required service work in connection with the Part is performed by a Taylor-authorized distributor or service agency.
3. The limited warranty applies only to Parts remaining in use by their original owner at their original installation location in the unit of original installation.
4. Installation, use, care, and maintenance must be normal and in accordance with all instructions contained in the Taylor Operator's Manual.
5. Defective Parts must be returned to the authorized Taylor distributor or service agency for credit.
6. This warranty is not intended to shorten the length of any warranty coverage provided pursuant to a separate Taylor Limited Warranty on freezer or grill equipment.
7. The use of any refrigerant other than that specified for the unit in which the Part is installed will void this limited warranty.

^{1, 2} Except that Taylor Part #032129SER2 (Compressor-Air-230V SERV) and Taylor Part #075506SER1 (Compressor-Air-115V 60HZ) shall have a limited warranty period of twelve (12) months when used in Taylor freezer equipment and a limited warranty period of two (2) years when used in Taylor grill equipment.

LIMITED WARRANTY ON PARTS

LIMITED WARRANTY EXCEPTIONS

This limited warranty does **not** cover:

1. Labor or other costs incurred for diagnosing, repairing, removing, installing, shipping, servicing, or handling of defective Parts, replacement Parts, or new Parts.
2. Normal maintenance, cleaning, and lubrication as outlined in the Taylor Operator's Manual, including cleaning of condensers or carbon and grease buildup.
3. Required service, whether cleaning or general repairs, to return the cooking surface assemblies, including the upper platen and lower plate, to an operational condition to achieve proper cooking or allow proper assembly of release sheets and clips as a result of grease buildup on the cooking surfaces, including but not limited to the platen and plate, sides of the shroud, or top of the shroud.
4. Replacement of cooking surfaces, including the upper platen and lower plate, due to pitting or corrosion (or in the case of the upper platen, due to loss of plating) as a result of damage due to the impact of spatulas or other small wares used during the cooking process or as a result of the use of cleaners, cleaning materials, or cleaning processes not approved for use by Taylor.
5. Replacement of wear items designated as Class "000" Parts in the Taylor Operator's Manual, as well as any release sheets and clips for the Product's upper platen assembly.
6. External hoses, electrical power supplies, and machine grounding.
7. Parts not supplied or designated by Taylor, or damages resulting from their use.
8. Return trips or waiting time required because a service technician is prevented from beginning warranty service work promptly upon arrival.
9. Failure, damage, or repairs due to faulty installation, misapplication, abuse, no or improper servicing, unauthorized alteration or improper operation or use as indicated in the Taylor Operator's Manual, including but not limited to the failure to use proper assembly and cleaning techniques, tools, or approved cleaning supplies.
10. Failure, damage, or repairs due to theft, vandalism, wind, rain, flood, high water, water, lightning, earthquake, or any other natural disaster, fire, corrosive environments, insect or rodent infestation, or other casualty, accident or condition beyond the reasonable control of Taylor; operation above or below the gas, electrical, or water supply specification of the unit in which a part is installed; or Parts or the units in which they are installed repaired or altered in any way so as to, in the judgment of Taylor, adversely affect performance, or normal wear or deterioration.
11. Any Part purchased over the Internet.
12. Failure to start due to voltage conditions, blown fuses, open circuit breakers, or damages due to the inadequacy or interruption of electrical service.
13. Electricity, gas, or other fuel costs, or increases in electricity or fuel costs for any reason whatsoever.
14. Damages resulting from the use of any refrigerant other than that specified for the unit in which the Part is installed will void this limited warranty.
15. Any cost to replace, refill, or dispose of refrigerant, including the cost of refrigerant.
16. **ANY SPECIAL, INDIRECT, OR CONSEQUENTIAL PROPERTY OR COMMERCIAL DAMAGE OF ANY NATURE WHATSOEVER.** Some jurisdictions do not allow the exclusion of incidental or consequential damages, so this limitation may not apply to you.

This limited warranty gives you specific legal rights, and you may also have other rights which vary from jurisdiction to jurisdiction.

LIMITATION OF WARRANTY

THIS LIMITED WARRANTY IS EXCLUSIVE AND IS IN LIEU OF ALL OTHER WARRANTIES, CONDITIONS, AND/OR REMEDIES UNDER THE LAW, INCLUDING ANY IMPLIED WARRANTIES OR CONDITIONS OF MERCHANTABILITY OR FITNESS FOR A PARTICULAR PURPOSE. THE ORIGINAL OWNER'S SOLE REMEDY WITH RESPECT TO ANY PRODUCTS SHALL BE REPAIR OR REPLACEMENT OF DEFECTIVE PARTS UNDER THE TERMS OF THIS LIMITED WARRANTY. ALL RIGHTS TO CONSEQUENTIAL OR INCIDENTAL DAMAGES, (INCLUDING CLAIMS FOR LOST SALES, LOST PROFITS, PRODUCT LOSS, PROPERTY DAMAGES, OR SERVICE EXPENSES) ARE EXPRESSLY EXCLUDED. THE EXPRESS WARRANTIES MADE IN THIS LIMITED WARRANTY MAY NOT BE ALTERED, ENLARGED, OR CHANGED BY ANY DISTRIBUTOR, DEALER, OR OTHER PERSON, WHATSOEVER.

LEGAL REMEDIES

The owner **must** notify Taylor in writing, by certified or registered letter to the following address, of any defect or complaint with the Part, stating the defect or complaint and a specific request for repair, replacement, or other correction of the Part under warranty, mailed at least thirty (30) days before pursuing any legal rights or remedies.

Taylor Company
750 N. Blackhawk Blvd.
Rockton, IL 61072, U.S.A.

