

OPERATOR'S MANUAL



Model C300NP Non-Pressurized Slush Freezer

Original Operating Instructions

055072NP

9/22/06 (Original Publication)
(Updated 9/3/2020)

Section 1: To the Installer

Installer Safety	1-1
Site Preparation	1-1
Air-Cooled Machines	1-2
Water-Cooled Refrigeration Machines	1-2
Water Connections	1-2
Electrical Connections	1-3
Beater Rotation	1-4
Refrigerant	1-4

Section 2: To the Operator

Compressor Warranty Disclaimer	2-2
--	-----

Section 3: Safety

Section 4: Operator Parts Identification

Exploded View	4-1
Beater Door Assembly	4-2
Accessories	4-3

Section 5: User Interface

Symbol Definitions	5-1
Control Switch	5-2
Liquid Crystal Display	5-2
Operational Mode Display	5-2
Operator Menu Display	5-2
Operator Menu Timeout	5-2
Finding Current Fault Conditions	5-3
Syrup Out Indicator	5-7
CO ₂ Out Indicator	5-7
Water Out Indicator	5-7
Audio Alarm Silencer	5-7
Product Light	5-7
Sampling Valve	5-7
Daily Procedures	5-7

Table of Contents

Section 6: Operating Procedures

Assembly	6-1
Sanitizing	6-6
Priming/Brixing	6-8
120 Day Closing Procedure	6-10
Draining Product from the Freezing Cylinder	6-10
Rinsing	6-10
Cleaning	6-11
Disassembly	6-12
Brush-Cleaning	6-12

Section 7: Operator Checklist

During Cleaning and Sanitizing	7-1
Troubleshooting Bacterial Count	7-1
Regular Maintenance Checks	7-1
Winter Storage	7-1

Section 8: Troubleshooting Guide

Section 9: Parts Replacement Schedule

Section 10: Limited Warranty on Equipment

Section 11: Limited Warranty on Parts

The following information has been included in the manual as safety and regulatory guidelines. For complete installation instructions, please see the Installation Checklist.

Installer Safety



IMPORTANT! In all areas of the world, equipment should be installed in accordance with existing local codes. Please contact your local authorities if you have any questions.

Care should be taken to ensure that all basic safety practices are followed during the installation and servicing activities related to the installation and service of Taylor® equipment.

- Only authorized Taylor service personnel should perform installation, maintenance, and repairs on Taylor equipment.
- Authorized service personnel should consult OSHA Standard 29CFR1910.147 or the applicable code of the local area for the industry standards on lockout/tagout procedures before beginning any installation or repairs.
- Authorized service personnel must ensure that the proper protective equipment (PPE) is available and worn when required during installation and service.
- Authorized service personnel must remove all metal jewelry, rings, and watches before working on electrical equipment.



DANGER! The main power supply(s) to the machine must be disconnected prior to performing any installation, maintenance, or repairs. Failure to follow this instruction may result in personal injury or death from electrical shock or hazardous moving parts, as well as poor performance or damage to the machine.

Note: All repairs must be performed by a Taylor service technician.



WARNING! This machine has many sharp edges that can cause severe injuries.

Site Preparation

Review the area where the machine will be installed. Make sure that all possible hazards to the user and machine have been addressed.



WARNING! Only install this machine in a location where its use and maintenance is restricted to trained personnel. Failure to comply may result in personal injury.

For Indoor Use Only: This machine is designed to operate indoors, under normal ambient temperatures of 70°F to 75°F (21°C to 24°C). The machine has successfully performed in high ambient temperatures of up to 104°F (40°C) at reduced capacities.



WARNING! This machine must **NOT** be installed in an area where a water jet or hose can be used. **NEVER** use a water jet or hose to rinse or clean the machine. Failure to follow this instruction may result in electrocution.



CAUTION! This machine must be installed on a level surface to avoid the hazard of tipping. Extreme care should be taken in moving this machine for any reason. Two or more persons are required to safely move this machine. Failure to comply may result in personal injury or damage to the machine.

The authorized installer should inspect the machine for damage and promptly report any damage to the local authorized Taylor distributor.

This machine is made using USA sizes of hardware. All metric conversions are approximate and vary in size.

Air-Cooled Machines

Do not obstruct air intake and discharge openings.

Air-cooled machines require a minimum of 3 in. (76 mm) of clearance around **all** sides of the freezer and 12 in. (305 mm) of clearance on the top to allow for adequate air flow across the condensers. Failure to allow adequate clearance can reduce the refrigeration capacity of the freezer and possibly cause permanent damage to the compressor.

Water-Cooled Refrigeration Machines

(Water-Cooled Machines Only)

On the back of the machine, two additional 3/8 in. (9.5 mm) F.P.T. water connections for condenser inlet and outlet have been provided for easy hookup. Permanently connect machine using 3/8 in. (9.5 mm) inside diameter water lines. Flexible lines are recommended if local codes permit. Failure to use adequately sized water lines may cause the machine to go on high head pressure and shut down.

Do not install a hand shutoff valve on the out line.

Water-cooled machines are counter flow and the water should flow in this order: first through the automatic water valve; second, through the inlet located at the bottom of the condenser; third, through the outlet fitting located at the top of the condenser **to an open trap drain**.

Important! Water pressures are preset at the factory. **Do not adjust the water pressure.** Improper water adjustments may cause operation discrepancies.



IMPORTANT! A backflow prevention device is required on the incoming water connection side. Please see the applicable national, state, and local codes for determining the proper configuration. Water pressure to the unit must not exceed 150 psi (1034 kPa).

Water Connections

An adequate cold water supply must be provided with a hand shutoff valve. On the back of the machine, two 3/8 in. (9.5 mm) male flare water connections have been provided for easy hookup. Permanently connect machine using 3/8 in. (9.5 mm) inside diameter water lines. A flexible line is recommended, if local codes permit. A minimum of 25 psi. (172 kPa) water pressure is required to avoid having the machine cut out the low

water pressure switch. A booster pump must be provided if this pressure is not available.

Note: Water lines beyond 200 ft. (61 m) require 1/2 in. (13 mm) water lines.



IMPORTANT! A backflow prevention device is required on the incoming water connection side. Please see the applicable national, state, and local codes for determining the proper configuration. Water pressure to the unit must not exceed 150 psi (1034 kPa).

Depending on local water conditions, it may be advisable to install a water strainer to prevent foreign substances from clogging the automatic water valve.

It is always a good practice to have a filter system to improve the quality of the water and to avoid clogging the operating components.

Important! The water filter (064422-SER) must be thoroughly flushed with water before connecting it to the machine. This removes any loose particles present from the manufacture of the filter that could clog the flow control. To flush the filter, connect the inlet end of the filter to the water supply. Position the outlet end of the filter over an empty pail. Open the water supply. Allow water to flow through the filter until the water exiting the filter is clear. Close the water supply. Attach the outlet end of the filter to the machine. Reopen the water supply.

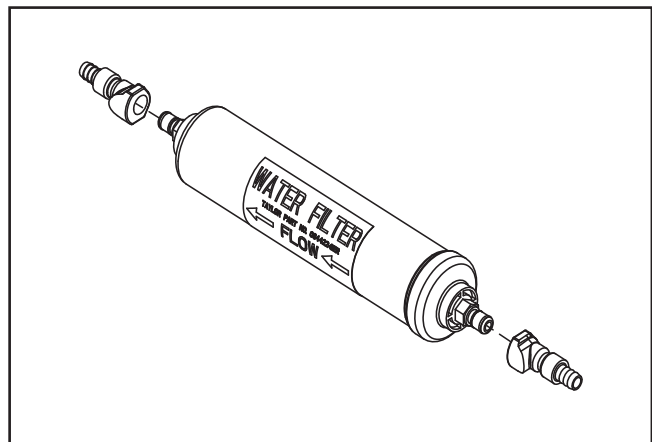

Figure 1-1

Electrical Connections



IMPORTANT! In the United States, this machine is intended to be installed in accordance with the National Electrical Code (NEC), ANSI/NFPA 701987.

The purpose of the NEC code is the practical safeguarding of persons and property from hazards arising from the use of electricity. This code contains provisions considered necessary for safety.

In all other areas of the world, the machine should be installed in accordance with the existing local codes. Please contact your local authorities if you have any questions.

Each machine requires one power supply for each data label on the machine. Check the data label(s) on the machine for branch circuit overcurrent protection or fuse, circuit ampacity, and other electrical specifications.

See the wiring diagram provided inside the electrical box for proper power connections.



FOLLOW YOUR LOCAL ELECTRICAL CODES.



WARNING! This machine must be properly grounded. Failure to do so can result in severe personal injury from electrical shock.



WARNING! Avoid injury.

- **DO NOT** operate the machine unless it is properly grounded.
- **DO NOT** operate the machine with fuses larger than specified on the machine's data label.
- All repairs should be performed by an authorized Taylor service technician.
- The main power supplies to the machine must be disconnected prior to performing installation, repairs, or maintenance.
- **For Cord-Connected Machines:** Only Taylor service technicians or licensed electricians may install a plug or replacement cord on the machine.

- Machines that are permanently connected to fixed wiring and for which leakage currents may exceed 10 mA, particularly when disconnected or not used for long periods, or during initial installation, shall have protective devices to protect against the leakage of current, such as a GFI, installed by the authorized personnel to local codes.
- Stationary machines that are not equipped with a power cord and a plug or another device to disconnect the appliance from the power source must have an all-pole disconnecting device with a contact gap of at least 0.125 in. (3 mm) in the external installation.
- Supply cords used with this machine shall be oil-resistant, sheathed flexible cable not lighter than ordinary polychloroprene or other equivalent synthetic elastomer-sheathed cord (code designation 60245 IEC 57) installed with the proper cord anchorage to relieve conductors from strain, including twisting, at the terminals and protect the insulation of the conductors from abrasion.
- If the supply cord is damaged, it must be replaced by the manufacturer, service agent, or a similarly qualified person to avoid a hazard.
- Secure supply cord ground lead to machine in a location where if the cord is pulled the main power leads become taut before the ground lead can break loose.

Failure to follow these instructions may result in electrocution. Contact your local authorized Taylor distributor for service.



IMPORTANT! An equipotential grounding lug is provided with this machine. Some countries require the grounding lug to be properly attached to the rear of the frame by the authorized installer. The installation location is marked by the equipotential bonding symbol (5021 of IEC 60417-1) on both the removable panel and the machine's frame.

Beater Rotation



NOTICE! Beater rotation must be clockwise as viewed looking into the freezing cylinder.

1 To correct the rotation on a three-phase machine, interchange any two incoming power supply lines at the freezer main terminal block only. To correct rotation on a single-phase machine, exchange leads inside the beater motor. (Follow the diagram printed on the motor.)

Electrical connections are made directly to the terminal block provided in the main control box located behind the service panel.

It is recommended that beater rotation adjustment be performed by a Taylor service technician.

Refrigerant



CAUTION! This machine contains fluorinated greenhouse gases (F-Gas) to provide refrigeration using a hermetically sealed circuit or within foam insulation. This machine's type of gas, quantity, Global Warming Potential (GWP), and CO₂ tonnes equivalent information is recorded on the machine's data label. The refrigerant used is generally considered nontoxic and nonflammable. However any gas under pressure is potentially hazardous and must be handled with caution.

NEVER fill any refrigerant cylinder completely with liquid. Filling the cylinder approximately 80% will allow for normal expansion.



CAUTION! Use only approved refrigerant listed on the machine's data label or authorized through a manufacturer's technical bulletin. The use of any other refrigerant may expose users and operators to unexpected safety hazards.



WARNING! Refrigerant liquid sprayed onto the skin may cause serious damage to tissue. Keep eyes and skin protected. If refrigerant burns should occur, flush the area immediately with cold water. If burns are severe, apply ice packs and contact a physician immediately.



NOTICE! Taylor reminds technicians to be aware of and in compliance with local government laws regarding refrigerant recovery, recycling, and reclaiming systems. For information regarding applicable local laws, please contact your local authorized Taylor distributor.



IMPORTANT! Refrigerants and their associated lubricants may be extremely moisture absorbent. When opening a refrigeration system, the maximum time the system is open must not exceed 15 minutes. Cap all open tubing to prevent humid air or water from being absorbed by the oil.

The freezer you have purchased has been carefully engineered and manufactured to give you dependable operation.

The Model C300NP, when properly operated and cared for, will produce a consistent quality product. Like all mechanical products, this machine will require cleaning and scheduled maintenance. A minimum amount of care and attention is necessary if the operating procedures outlined in this manual are followed closely.



IMPORTANT! This manual should be read before operating or performing any maintenance on the machine.

Your Taylor machine will **NOT** compensate for and/or correct any errors made during the setup or filling operations. Thus, the initial assembly, setup, and priming procedures are of extreme importance. It is strongly recommended that all personnel responsible for the machine's operation, including assembly and disassembly, go through these procedures together in order to be properly trained and to make sure that all personnel understand their role in using and maintaining the machine.

In the event you should require technical assistance, please contact your local authorized Taylor distributor.

Note: Your Taylor warranty is valid only if the parts are authorized Taylor parts, purchased from the local authorized Taylor distributor, and only if all required service work is provided by an authorized Taylor service technician. Taylor reserves the right to deny warranty claims on units or parts if non-Taylor approved parts or incorrect refrigerant were installed in the unit, system modifications were performed beyond factory recommendations, or it is determined that the failure was caused by abuse, misuse, neglect, or failure to follow all operating instructions. For full details of your Taylor warranty, please see the Limited Warranty section in this manual.



IMPORTANT! If the crossed-out wheeled-bin symbol is affixed to this machine, it signifies that this machine is compliant with the EU Directives as well as other similar end-of-life legislation in effect after August 13, 2005. Therefore, it must be collected separately after its use is completed and cannot be disposed as unsorted municipal waste.

The user is responsible for delivering the machine to the appropriate collection facility, as specified by your local code.

For additional information regarding applicable local disposal laws, please contact the municipal waste facility and/or local authorized Taylor distributor.

Compressor Warranty Disclaimer

The refrigeration compressor(s) on this unit are warranted for the term stated in the Limited Warranty section in this manual. However, due to the Montreal Protocol and the U.S. Clean Air Act Amendments of 1990, many new refrigerants are being tested and developed, thus seeking their way into the service industry. Some of these new refrigerants are being advertised as drop-in replacements for numerous applications. It should be noted that in the event of ordinary service to this unit's refrigeration system, **only the refrigerant specified on the affixed data label should be used.** The unauthorized use of alternate refrigerants will void your Taylor compressor warranty. It is the unit owner's responsibility to make this fact known to any technician he employs.

It should also be noted that Taylor does not warrant the refrigerant used in its equipment. For example, if the refrigerant is lost during the course of ordinary service to this machine, Taylor has no obligation to either supply or provide its replacement either at billable or unbillable terms. Taylor does have the obligation to recommend a suitable replacement if the original refrigerant is banned, obsoleted, or no longer available during the five year warranty of the compressor.

Taylor will continue to monitor the industry and test new alternates as they are being developed. Should a new alternate prove, through our testing, that it would be accepted as a drop-in replacement, then the above disclaimer would become null and void. To find out the current status of an alternate refrigerant as it relates to your compressor warranty, call the local Taylor distributor or the Taylor factory. Be prepared to provide the model/serial number of the unit in question.

We at Taylor Company are concerned about the safety of the operator when he or she comes in contact with the freezer and its parts. Taylor has gone to extreme efforts to design and manufacture built-in safety features to protect both the operator and the service technician. As an example, warning labels have been attached to the freezer to further point out safety precautions.



DANGER! Failure to adhere to the following safety precautions may result in severe personal injury or death. Failure to comply with these warnings may also damage the unit and/or its components. Such damage may result in component replacement and service repair expenses.



NOTICE! DO NOT operate this machine without reading this entire manual first. Failure to follow all of these operating instructions may result in damage to the machine, poor performance, health hazards, or personal injury.



IMPORTANT! *This machine is to be used only by trained personnel. It is not intended for use, cleaning, or maintenance by children or people with reduced physical, sensory, or mental capabilities or lack of experience and knowledge, unless given supervision or instruction concerning the use of the machine by a person responsible for their safety. Children should be supervised to ensure that they do not play with the machine.*



WARNING! Avoid injury.

- **DO NOT** allow untrained personnel to operate this machine.
- **DO NOT** operate the machine unless all service panels and access doors are restrained with screws.

- **DO NOT** remove any internal operating parts (including, but not limited to, freezer door, beater, or scraper blades), unless all control switches are in the OFF position.

Failure to follow these instructions may result in severe personal injury, especially to fingers or hands, from hazardous moving parts.



IMPORTANT! *An equipotential grounding lug is provided with this machine. Some countries require the grounding lug to be properly attached to the rear of the frame by the authorized installer. The installation location is marked by the equipotential bonding symbol (5021 of IEC 60417-1) on both the removable panel and the machine's frame.*



WARNING! Avoid injury.

- **DO NOT** operate the machine unless it is properly grounded.
- **DO NOT** operate the machine with fuses larger than specified on the machine's data label.
- All repairs should be performed by an authorized Taylor service technician.
- The main power supplies to the machine must be disconnected prior to performing installation, repairs, or maintenance.
- **For Cord-Connected Machines:** Only Taylor service technicians or licensed electricians may install a plug or replacement cord on the machine.
- Machines that are permanently connected to fixed wiring and for which leakage currents may exceed 10 mA, particularly when disconnected or not used for long periods, or during initial installation, shall have protective devices to protect against the leakage of current, such as a GFI, installed by the authorized personnel to local codes.
- Stationary machines that are not equipped with a power cord and a plug or another device to

disconnect the appliance from the power source must have an all-pole disconnecting device with a contact gap of at least 0.125 in. (3 mm) in the external installation.

- Supply cords used with this machine shall be oil-resistant, sheathed flexible cable not lighter than ordinary polychloroprene or other equivalent synthetic elastomer-sheathed cord (code designation 60245 IEC 57) installed with the proper cord anchorage to relieve conductors from strain, including twisting, at the terminals and protect the insulation of the conductors from abrasion.
- If the supply cord is damaged, it must be replaced by the manufacturer, service agent, or a similarly qualified person to avoid a hazard.
- Secure supply cord ground lead to machine in a location where if the cord is pulled the main power leads become taut before the ground lead can break loose.

Failure to follow these instructions may result in electrocution. Contact your local authorized Taylor distributor for service.



WARNING! This machine must **NOT** be installed in an area where a water jet or hose can be used. **NEVER** use a water jet or hose to rinse or clean the machine. Failure to follow this instruction may result in electrocution.



WARNING! This machine is pressurized when in operation. The control switch must be in the OFF position until the machine is completely assembled. No part should ever be removed from the machine while it is in operation. No parts should be removed until the control switch has been turned to the OFF position.

- **DO NOT** allow untrained personnel to operate this machine.
- **DO NOT** operate the freezer unless all service panels and access doors are restrained with screws.
- **DO NOT** remove any internal operating parts (example: freezer door, beater, scraper blades, etc.) unless all control switches are in the OFF position.

Failure to follow this instruction may result in severe personal injury from hazardous moving parts or from the

impact of propelled parts.



WARNING! This machine has many sharp edges that can cause severe injuries.

- **DO NOT** put objects or fingers in the door spout. This may contaminate the product and cause severe personal injury from blade contact.
- **USE EXTREME CAUTION** when removing the beater assembly. The scraper blades are very sharp.



CAUTION! This machine must be installed on a level surface to avoid the hazard of tipping. Extreme care should be taken in moving this machine for any reason. Two or more persons are required to safely move this machine. Failure to comply may result in personal injury or damage to the machine.

The authorized installer should inspect the machine for damage and promptly report any damage to the local authorized Taylor distributor.

This machine is made using USA sizes of hardware. All metric conversions are approximate and vary in size.



WARNING! Only install this machine in a location where its use and maintenance is restricted to trained personnel. Failure to comply may result in personal injury.



NOTICE! Cleaning and sanitizing schedules are governed by your federal, state, or local regulatory agencies and must be followed accordingly. Please refer to the cleaning section of this manual for the proper procedure to clean this machine.



CAUTION! This machine is equipped with a refrigerated cabinet, designed to maintain product temperature at or below 41°F (5°C). Before replenishing the mix supply, the product must be refrigerated at or below 41°F (5°C). Failure to follow this instruction may result in health hazards and poor freezer performance.

DO NOT run the machine without product. Failure to follow this instruction can result in damage to the machine.

DO NOT obstruct air intake and discharge openings. A minimum of 3 in. (76 mm) air clearance on both sides of the machine is required. It is recommended to place the rear of the machine against the wall to prevent the recirculation of warm air. Failure to follow this instruction may cause poor freezer performance and damage to the machine.

For Indoor Use Only: This machine is designed to operate indoors, under normal ambient temperatures of 70°F to 75°F (21°C to 24°C). The machine has successfully performed in high ambient temperatures of up to 104°F (40°C) at reduced capacities.

Noise Level: Airborne noise emission does not exceed 78 dB(A) when measured at a distance of 39 in. (1.0 m) from the surface of the machine and at a height of 62 in. (1.6 m) from the floor.

Exploded View

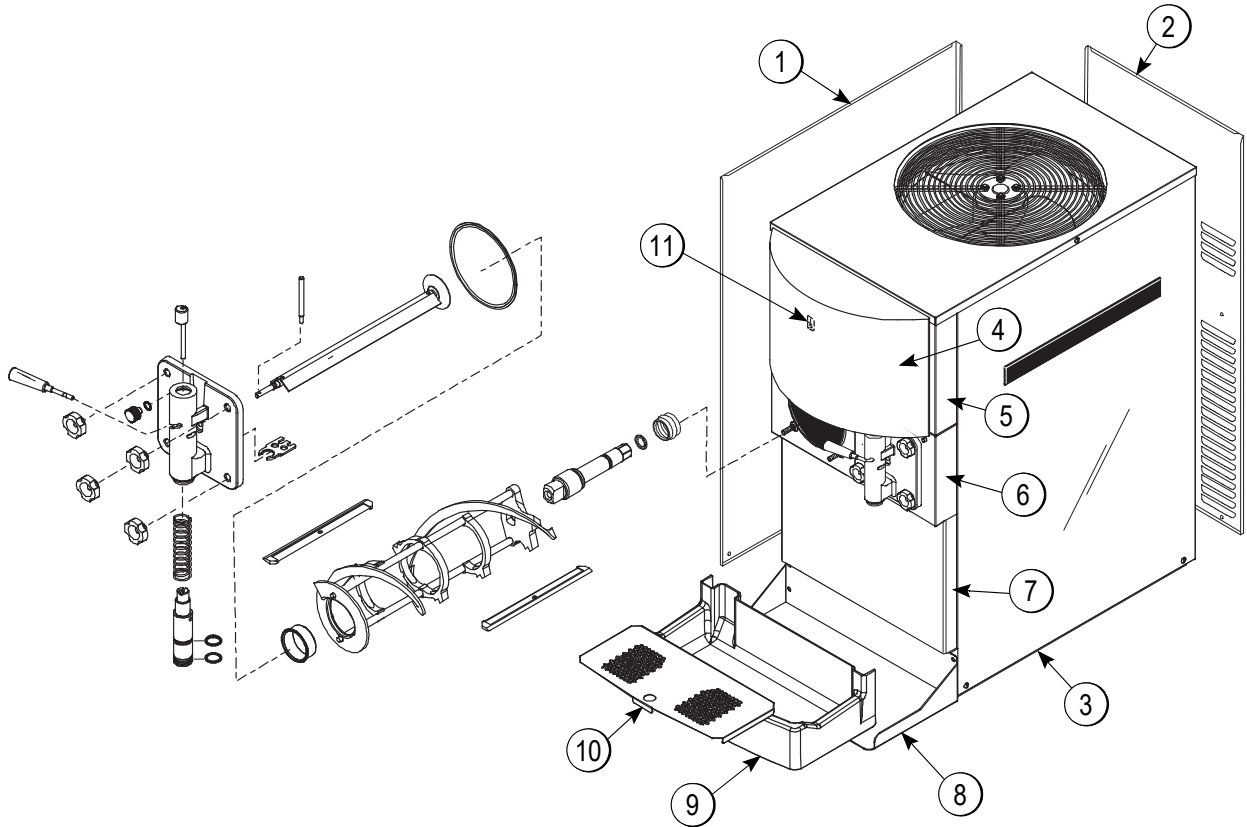

Figure 4-1

Item	Description	Part No.
1	Panel-Side-Left	054676
2	Panel-Rear	054672
3	Panel-Side-Right	054671
4	Display-Lighted	054683-27
5	Panel-Front-Upper	069142
6	Panel-Front-Shell	054668

Item	Description	Part No.
7	Panel-Front-Lower	054670
8	Shelf-Drip Tray	057938
9	Tray-Drip	057738
10	Shield-Splash	057939
11	Switch-Rocker-OFF-ON	078418

Beater Door Assembly

4

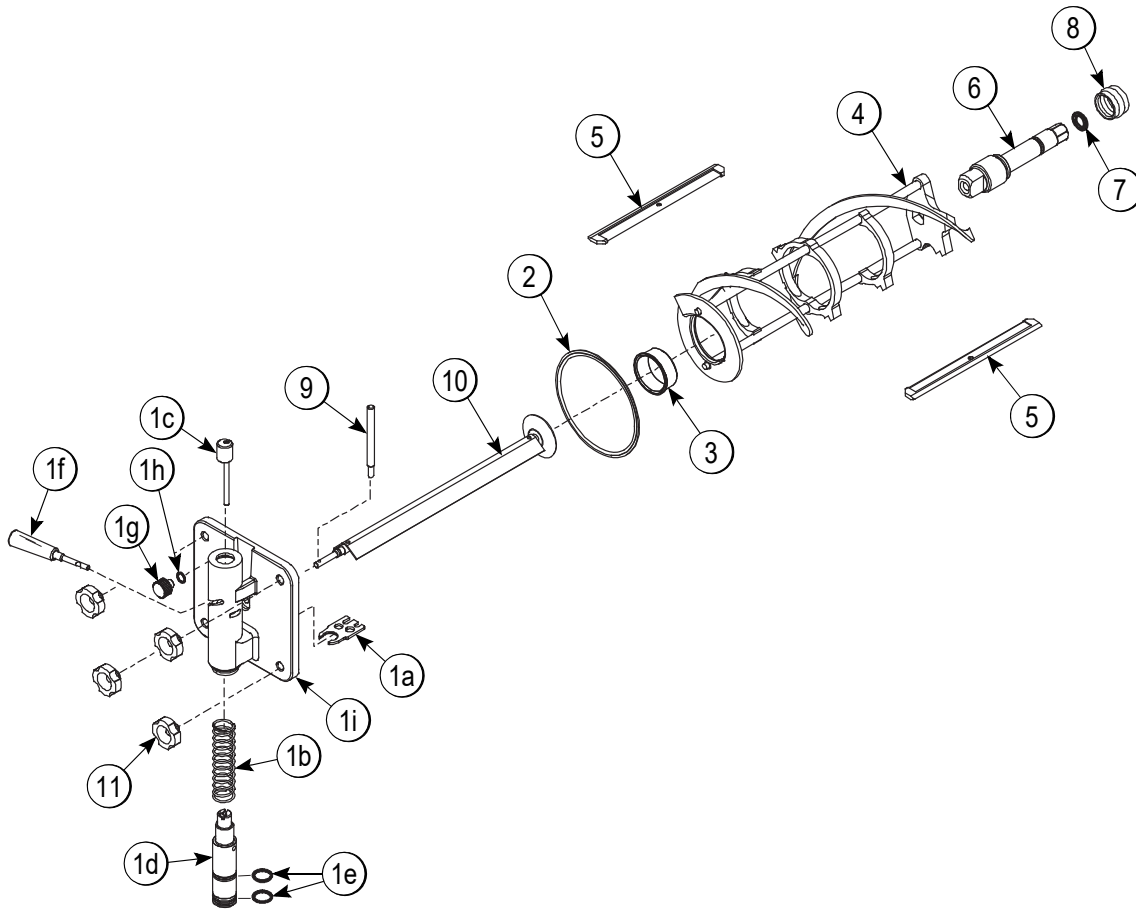
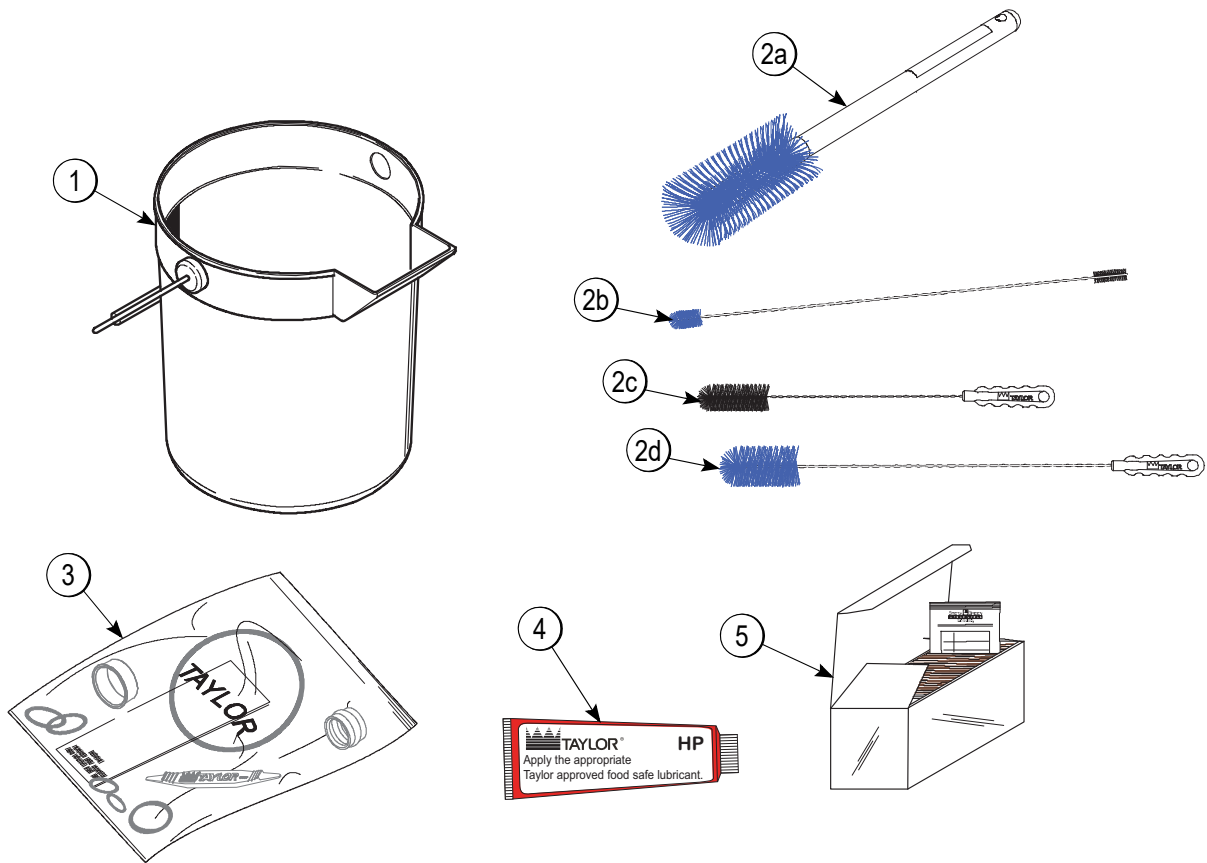

Figure 4-2

Item	Description	Part No.
1	Door A.-Slush-SLF-Close-Ice Buster	items 1a—1i
1a	Buster-Ice	047735
1b	Spring-Comp.970x.082x3.87	030344
1c	Pin A.-Valve Handle	X83812
1d	Valve-Draw Self Close	080662
1e	O-ring-1in.OD X.139w	032504
1f	Handle A.-Draw-Slushblack	X47384
1g	Plug-Prime*STNLS	050405
1h	O-ring-.563 OD X .070w-#013	043758
1i	Door A.-Slush-Partial Self Close	X83472SSP

Item	Description	Part No.
2	Gasket-Door 5.109 X 5.630	014030
3	Bearing-Front	013116
4	Beater A.-7qt-1 Pin	X46233
5	Blade-Scraper-Plastic	081094
6	Shaft-Beater	036412
7	O-ring-7/8 OD X .139w	025307
8	Seal-Drive Shaft	032560
9	Arm-Baffle	047729
10	Baffle A.	X47731
11	Nut-Stud	043666

Accessories



4

Figure 4-3

Item	Description	Part No.
1	Pail-10 Qt.	013163
2a	Brush-Mix Pump Body-3"x7"	023316
2b	Brush-Double Ended	013072
2c	Brush-Rear BRG 1"Dx2"L	013071

Item	Description	Part No.
2d	Brush-Draw Valve 1-1/2"OD	014753
3	Kit A.-Tune Up	X56829
4	Lubricant-Taylor Hi Perf	048232
5	Sanitizer-Stera Sheen	055492

NOTE: Items 2a—2d are included in Brush A.-package, part no. [X64275](#).

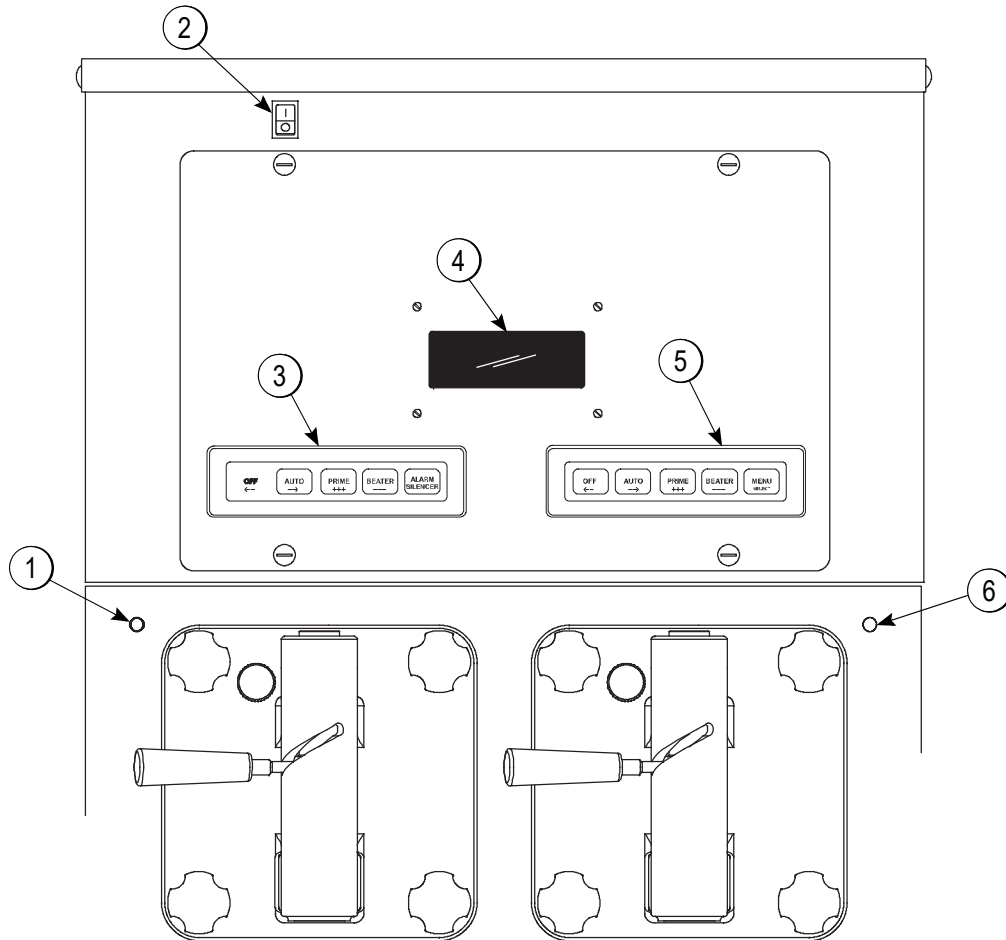
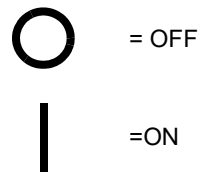

Figure 5-1

Symbol Definitions

To better communicate in the international arena, symbols have replaced words on many of our operator switches, function, and fault indicators. Your Taylor machine is designed with these international symbols. The following chart identifies the symbol definitions.



Item	Description
1	Product Light—Left Side
2	Control Switch
3	Keypad—Left Side
4	Liquid Crystal Display
5	Keypad—Right Side
6	Product Light—Right Side

Control Switch

The control switch is located at the top left corner of the control channel. When placed in the ON position, SLUSHTECH is able to operate.

Liquid Crystal Display

The liquid crystal display (LCD) is located on the front control panel. The LCD is used to show the current operating mode of the freezing cylinders. The LCD also indicates whether there is enough syrup, CO₂, and water being supplied to the freezer. If an error in the machine operation occurs, a warning tone will sound and the word FAULT will flash on the third line of the display.

Operational Mode Display

The following displays illustrate the Operational Mode Displays. This information appears on the LCD during normal operation.

When the machine is plugged into the wall receptacle and the control switch is in the ON position, this screen appears.

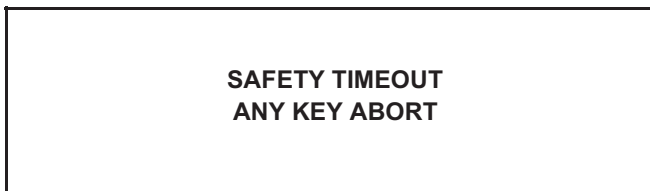

This display will remain on the LCD for 60 seconds unless a key is pressed. If any key is pressed (or 60 seconds pass), then the next screen appears.

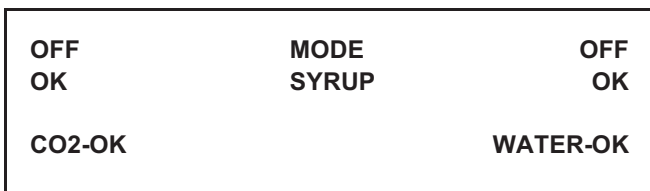

Note: Syrup, CO₂, and water are satisfied.

Pressing the AUTO (- ->) keys on both sides of the machine will display this screen.

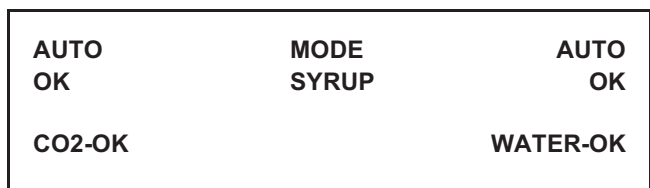

Line 1 indicates the operating mode for each freezing cylinder.

Line 2 indicates the status of the syrup systems in each freezing cylinder. As long as syrup is available, the word OK will appear on the LCD. When the syrup supply is insufficient, the word OUT will flash on the LCD. The same rules apply to the fourth line, which indicates the status of the CO₂ and the H₂O.

The third line of this display is a fault indicator. If an error in machine operation occurs, the word FAULT will be displayed on the LCD.

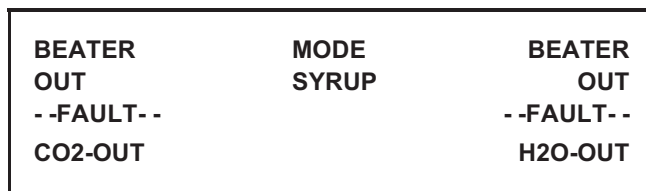

Operator Menu Display

The **OPERATOR MENU** is used to enter into the operating screens. To access the OPERATOR MENU, simply press the MENU (SEL) key. The cursor will flash under the letter A, indicating that this is screen A. To select a different screen, use the AUTO (- ->) and OFF (< -) keys to move the cursor to the desired screen selection and press the MENU (SEL) key.

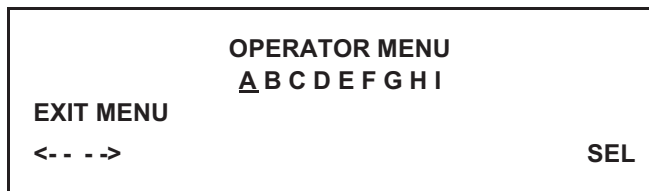

Operator Menu Timeout

If the display is left in the operator menu or any of the operator menu selections, except for Current Conditions, the display will return to the system mode screen 60 seconds after the last key press. The Current Conditions screen will be displayed until manually changed.

Finding Current Fault Conditions

Screen B is FAULT DESCRIPTION.

The fault description will indicate if there is a fault in one of the freezing cylinders. When the actual fault is corrected, the warning tone will stop. Only BRL NOT COOLING requires pressing the OFF (<- -) key to clear the fault message and the warning tone.

Table 5-1

Fault Messages	
Beater Overload	Beater is out on overload.
Chk Refrig Sys Psi	Compressor is out on high head pressure.
Thermistor Short	Shorted thermistor probe.
Thermistor Open	Open thermistor probe.
H2O Pressure Low	Water pressure is low.
CO2 Pressure Low	CO ₂ pressure is low.
Syrup Pressure Low	Syrup is no longer present.
BRL Temp 2 High	Freezing cylinder temperature is above 120°F (49°C).
BRL Not Cooling	Freezing cylinder is not cooling after 5 minutes.
No Fault Found	No fault conditions are apparent.

The following are explanations of the possible faults and the display screens. Fault messages 2 and 3 indicate the faults found in freezing cylinders 1 and 2 respectively.

NO FAULT FOUND—No fault conditions are apparent.

FAULT DESCRIPTION	
L:	NO FAULT FOUND
R:	NO FAULT FOUND
CLR	+++ SEL

BEATER OVERLOAD—Beater motor is out on overload. When this fault occurs, the machine automatically turns off. The fault clears when the condition is corrected.

FAULT DESCRIPTION	
L:	BEATER OVERLOAD
R:	BEATER OVERLOAD
CLR	+++ SEL

CHK REFRIG SYS PSI—Compressor is out on high head pressure. When this fault occurs, the machine automatically turns off. The fault clears when the condition is corrected.

FAULT DESCRIPTION	
L:	CHK REFRIG SYS PSI
R:	CHK REFRIG SYS PSI
CLR	+++ SEL

THERMISTOR SHORT—One or both of the barrel (freezing cylinder) thermistor probes are faulty.

FAULT DESCRIPTION	
L:	THERMISTOR SHORT
R:	NO FAULT FOUND
CLR	+++ SEL

THERMISTOR OPEN—One or both of the barrel (freezing cylinder) thermistor probes are faulty.

FAULT DESCRIPTION	
L:	THERMISTOR OPEN
R:	NO FAULT FOUND
CLR	+++ SEL

SYRUP PRESS LOW—When the syrup out indicator displays a lack of syrup, the machine will enter a Hold mode. At this time, no refrigeration or product flow from the flow control will be allowed. Only the beater will operate. When the syrup is satisfied, the machine will refill the product tank, and then automatically return to the Auto mode. The fault message and the warning tone will clear.

FAULT DESCRIPTION	
L:	NO FAULT FOUND
R:	SYRUP PRESS LOW
CLR	+++ SEL

USER INTERFACE

CO₂ PRESSURE LOW—When the CO₂ out indicator displays a lack of CO₂, a 60-second internal timer will start. If the CO₂ is not replenished at the end of the 60 seconds, both freezing cylinders will shut down, and this fault message will appear. Replenish the CO₂, and the fault message and warning tone will clear.

FAULT DESCRIPTION		
L: CO2 PRESSURE LOW		
R: CO2 PRESSURE LOW		
CLR	+++	SEL

H₂O PRESSURE LOW—When the water out indicator displays a lack of water, a 60-second internal timer will start. If the water is not replenished at the end of the 60 seconds, all freezing cylinders will shut down, and this fault message will appear. Replenish the water, and the fault message and warning tone will clear.

FAULT DESCRIPTION		
L: H2O PRESSURE LOW		
R: H2O PRESSURE LOW		
CLR	+++	SEL

BRL NOT COOLING—A freezing cylinder check has been established for the Auto mode of operation. If a freezing cylinder enters the Auto mode, the control will check product temperature. After 5 minutes, it will again check product temperature. If product temperature does not drop in that 5-minute time span, the freezing cylinder will shut down and this message will appear on the fault screen. For this check to be valid, the product temperature must be above 40°F (4.4°C).

FAULT DESCRIPTION		
L: BARREL NOT COOLING		
R: NO FAULT FOUND		
CLR	+++	SEL

BRL TEMP 2 HIGH—A maximum allowable product temperature has been established to prevent product from excessive heating. If the product exceeds 120°F (49°C) for any reason (in any mode of operation), the entire machine shuts down.

FAULT DESCRIPTION		
L: BARREL TEMP 2 HIGH		
R: NO FAULT FOUND		
CLR	+++	SEL

Faults, when corrected, are cleared from the Fault Description screen, with the following exception: BRL NOT COOLING. This fault requires the operator to press the OFF (<- -) key (when in the FAULT DESCRIPTION screen) in order for the fault to discontinue.

To see if there is more than one fault in either freezing cylinder, press the PRIME (+ + +) key. To return to the operator menu, press the MENU (SEL) key once. To return to the Main Screen, use the AUTO (- ->) key to cycle to menu item A, then press the MENU (SEL) key.

Screen C is SET CLOCK. Use the AUTO (- ->) and OFF (<- -) keys to place the cursor under the element to be set (hours, minutes, month, day, or year). Use the PRIME (+++) and BEATER (- - -) keys to increment or decrement the value. Press the MENU (SEL) key to advance to the Daylight Saving Time screen.

Note: The clock is programmed with military time.

SET CLOCK		
<u>14:30</u>		10/25/06
<- - -> + + +	- - -	SEL

This screen will appear if an invalid date is entered (example: if the date entered exceeds the days of that month).

SET CLOCK		
<u>14:30</u>		02/31/07
	INVALID DATE	SEL

This screen allows the Daylight Saving Time options. If the Daylight Saving Time option is enabled, then the time will be advanced by 1 hour at 2:00 a.m. on the first Sunday in April, and will be retarded by 1 hour at 2:00 a.m. on the last Sunday in October.

DAYLIGHT SAVING TIME	
<u>ENABLE</u>	DISABLE
<-- -->	SEL

Screen D is MANUAL DEFROST.

This screen allows the operator to **manually defrost** the left or right side of the machine.

Place the cursor under YES, press the MENU (SEL) key, and the command will be executed.

MANUAL DEFROST	
LEFT SIDE	<u>YES</u> NO
<-- -->	SEL

MANUAL DEFROST	
RIGHT SIDE	<u>YES</u> NO
<-- -->	SEL

Note: Only one side of the machine may be placed in the Defrost mode at a given time. Attempting to place a side of the machine into Defrost mode while the other side is defrosting, will result in the following screen:

ALREADY IN DEFROST

Press the MENU (SEL) key to return the machine to the operator menu.

Screen E is SYSTEM INFORMATION.

It consists of six display features.

The first feature indicates the software version.

SYSTEM INFORMATION	
C300 CONTROL UVC2	
VERSION 1.03	
	SEL

The second feature indicates the bill of material number and the serial number. It also indicates if the machine is equipped with a water pressure switch.

B.O.M. C30027C000	
S/N K0000000	
WITH H2O PRESS SW	
	SEL

The third feature indicates the version number of the language and text.

SYSTEM INFORMATION	
LANGUAGE	
VERSION 1.09	ENGLISH 446
	SEL

The fourth feature will display the Power Saver mode, OFF, REST, or STANDBY status.

If the Power Saver mode is OFF, the following screen will be displayed:

POWER SAVER MODE	
OFF	
	SEL

If a Power Saver mode is programmed, one of the following screens will appear:

POWER SAVER STANDBY		
CYCLE <u>1</u>	SUN	01:00
	SUN	08:30
+++	---	SEL

The fifth feature will indicate the left side defrost time and which day(s) the defrost will occur.

DEFROST TIME LEFT		
CYCLE <u>1</u>	ALL	09:00
+++	---	SEL

DEFROST TIME LEFT		
CYCLE <u>1</u>	SUN	09:00
<-- -->	+++	---
		SEL

USER INTERFACE

The sixth feature will indicate the right side defrost time and which day(s) the defrost will occur.

```

DEFROST TIME RIGHT
CYCLE 1          ALL          10:00
                + + +          - - -          SEL
    
```

```

DEFROST TIME RIGHT
CYCLE 1          SUN          10:00
<- - ->          + + +          - - -          SEL
    
```

Press the MENU (SEL) key to return to the operator menu.

Screen F is CURRENT CONDITIONS.

This screen displays the current viscosity, product temperature, and pressure for each freezing cylinder. An asterisk will indicate which side is refrigerating. Press the MENU (SEL) key to return to the operator menu.

5 **Note:** Viscosity is checked only when product temperature is below 40°F (4.4°C).

```

CURRENT CONDITIONS
L*1200Hd      27.3F
R*1200Hd      27.3F
                                   SEL
    
```

Screen G is FAULT HISTORY.

This option provides a record of the last 20 faults. The display also indicates the date and time each fault occurs.

```

FAULT HISTORY          1
10/25/06              08:34
NO FAULT FOUND
<- - -> + + +          - - -          SEL
    
```

Press the AUTO (- ->) and OFF (<- -) keys to increase or decrease the fault page.

Page numbers are located in the upper right-hand corner of the display. The most recently recorded fault will appear on page 1. The fault description is listed on the

third line of the fault page.

```

FAULT HISTORY          2
10/25/06
R SYRUP PRESS LOW    08:33
<- - -> + + +          - - -          SEL
    
```

Press the AUTO (- ->) key to move to the next screen. The next screen will indicate when the fault was satisfied.

```

FAULT HISTORY          2
10/25/06              14:06:19
RESTORED FROM FAULT
PAGE 2               + + +          - - -          SEL
    
```

Press the MENU (SEL) key to return to the operator menu.

Screen H is RINSE/SANITIZE.

This screen allows the operator to rinse or sanitize the freezing cylinder(s).

```

                RINSE / SANITIZE
RINSE          SANITIZE          EXIT
                - - -
<- - ->          SEL
    
```

Use the AUTO (- ->) and OFF (<- -) keys to select either RINSE or SANITIZE, and then press the MENU (SEL) key.

```

                SANITIZE
LEFT  SIDE          YES          NO
<- - ->          SEL          - - -
    
```

Use the cursor keys to select YES or NO, then press the MENU (SEL) key.

```

                SANITIZE
RIGHT SIDE          YES          NO
<- - ->          SEL          - - -
    
```

Repeat for the right side of the machine.

Screen I is **SERVICE MENU**.

This screen allows the service technician to access service information. Press the MENU (SEL) key to return to the operator menu.



Syrup Out Indicator

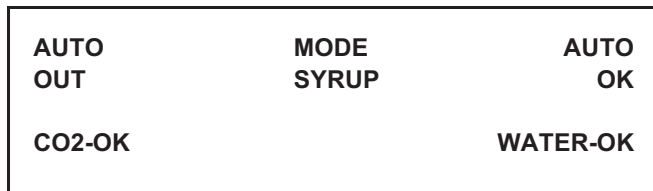

If the word OUT appears in one of the columns next to the word SYRUP, it indicates a lack of syrup or syrup pressure being supplied for the indicated freezing cylinder. If the machine is in the Auto or Prime modes, the PRODUCT NOT READY lamp will illuminate and a warning tone will sound for that freezing cylinder. At this time, replace the appropriate bag-in-the-box. As a safety feature, the refrigeration system automatically stops to prevent a freeze-up in the freezing cylinder.

If a syrup out condition occurs on one side, that side will enter the Hold mode, at which time the refrigeration remains off and the beater continues to run. The opposite side will not be affected. When the syrup is satisfied, the machine will refill the product tank and then automatically return to the Auto mode.

CO₂ Out Indicator

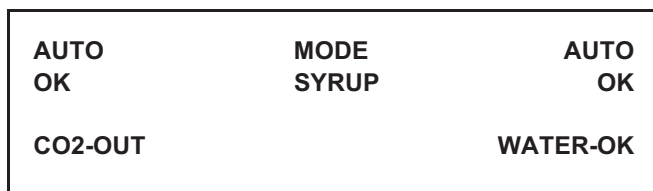

On the LCD, if the word OUT appears next to CO₂, it indicates a lack of CO₂ being supplied to the freezer. The product light will also illuminate, and a warning tone will sound. This will continue until the CO₂ is replaced. If the CO₂ is not replaced within 1 minute, the machine will shut down and a fault message will appear.

Water Out Indicator

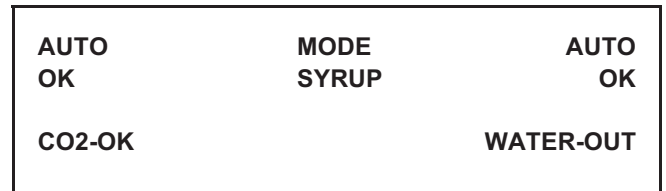

On the LCD, if the word OUT appears next to the word WATER, it indicates a lack of water being supplied to the freezer. In addition, the product light will illuminate, and a warning tone will sound. This will continue until the proper amount of water is supplied to the freezer. If the water is not supplied within 1 minute, the machine will shut down and a fault message will appear.

Audio Alarm Silencer

The audio alarm will be disabled if the ALARM SILENCE key is pressed. If a new fault or fault condition occurs or the system mode changes, the audio alarm will be re-enabled automatically. If the audio alarm is silenced for greater than 30 minutes without correcting the fault, it will be re-enabled automatically.

Product Light

When the light is continuously lit (not flashing) it indicates that there is an OUT condition for syrup, water, or CO₂.

When the light is flashing, it indicates that the product is not at serving viscosity. This will occur during the initial freeze down, a defrost cycle, a FAULT condition, and power saver modes.

Sampling Valve

The sampling valve is located behind the lower front panel. The sampling valve is used to obtain a brix reading.

Daily Procedures

The following procedure should be performed **daily**.

Remove the splash shield and front drip tray. Take these parts to the sink and brush-clean them. Re-install the parts onto the freezer. Use a clean, sanitized towel and wipe down the front of the machine, including the doors and spouts.

The Model C300NP contains two 7 qt. (6.6 L) freezing cylinders.

The syrup flow control combines the two ingredients of water and syrup and sends this combination to the freezing cylinder. As product is drawn, new product will flow from the flow control into the freezing cylinder. CO₂ is supplied after the flow control to carbonate the product and aid in dispensing.

We begin our instructions at the point where the parts are disassembled and laid out to air-dry.

The following procedures will show you how to assemble the parts into the freezer, sanitize them, and prime the freezer with fresh product.

Duplicate the following procedures, where they apply, for the other freezing cylinder.

If you are disassembling the machine for the first time or need information to get to this starting point in our instructions, turn to “Disassembly” on page 6-12, and start there.

Assembly



WARNING! Make sure the control switch is in the OFF position to eliminate the chance of moving parts. Failure to follow this instruction may result in severe personal injury from hazardous moving parts.

Note: When lubricating parts, use an approved food-grade lubricant (example: Taylor Lube HP).

1. Slide the O-ring into the first groove on the driveshaft. Lubricate the groove, O-ring, the area where the boot seal snaps onto the driveshaft, and the shaft portion that comes in contact with the bearing on the beater driveshaft. **Do not** lubricate the hex end of the driveshaft.

Slide the seal over the shaft and groove until it snaps into place. Pinch the boot seal and fill the inside portion of the seal with 1/4 in. more lubricant.

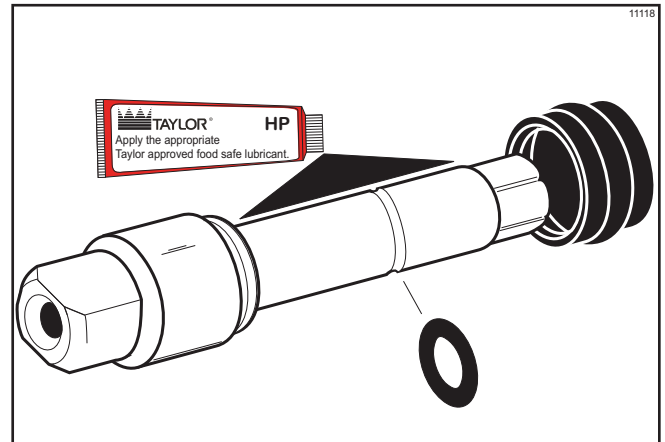

Figure 6-1

2. Insert the driveshaft into the freezing cylinder, (hex end first) and into the rear shell bearing, until the seal fits securely over the rear shell bearing. Make sure the driveshaft fits into the drive coupling without binding.

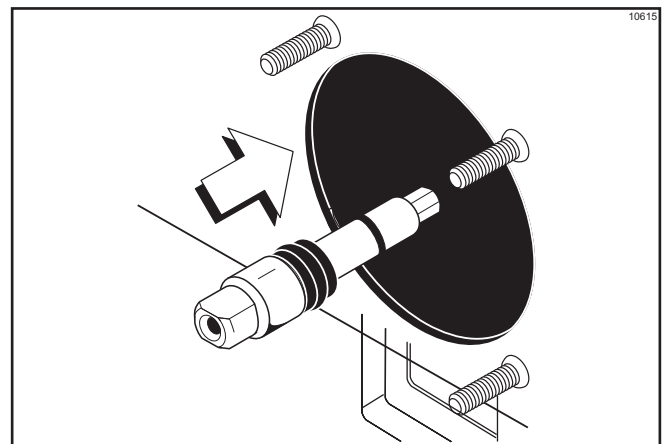

Figure 6-2



WARNING! Use extreme caution when handling the beater assembly. The scraper blades are very sharp and may cause injury.

3. Before installing the beater assembly, check the scraper blades for any signs of wear or damage. If a scraper blade is nicked or worn, replace both blades. Make sure the scraper blades are not bent and the slot is even for the entire length. Replace both blades if either is bent or uneven.

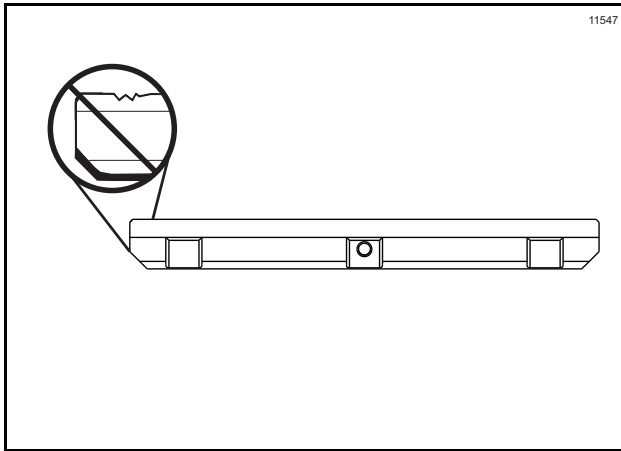

Figure 6-3

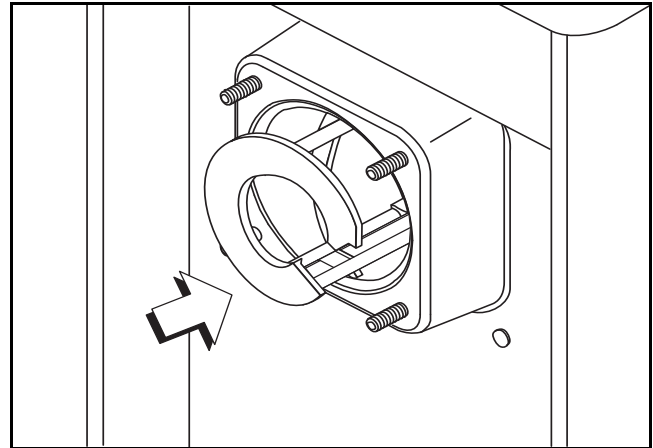

Figure 6-5

4. If the blades are in good condition, place the rear scraper blade over the single holding pin on the beater (knife edge to the outside). Holding the blade on the beater, turn it over and install the front blade the same way.

6. Install the white, plastic guide bearing on the short end of the baffle assembly. Slide the O-ring into the groove on the long end of the baffle assembly and lubricate the O-ring. Do not lubricate the guide bearing.

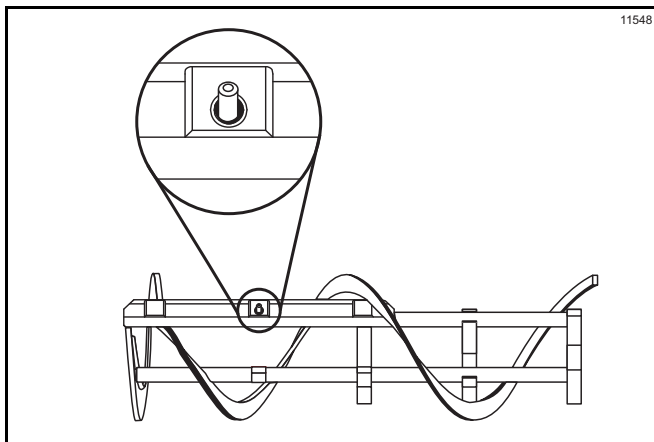

Figure 6-4

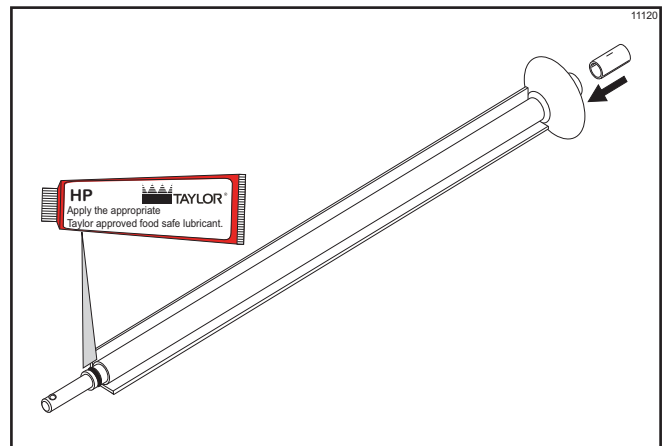

Figure 6-6

5. Holding the blades in position, insert the beater assembly into the freezing cylinder and slide it into position over the driveshaft. Turn the beater slightly to make sure that the beater is properly seated. When in position, the beater will not protrude beyond the front of the freezing cylinder.

7. Insert the short end of the baffle assembly into the pilot hole in the center of the driveshaft. The hole in the baffle assembly shaft should be rotated to the 12 o'clock position.
8. Before assembling the freezer door, check the following for any nicks, cracks, or signs of wear: front bearing, door gasket, draw valve, O-rings, and all sides of the door assembly, including the inside of the draw valve bore. Replace any damaged parts.
9. Install the O-rings on the draw valve and lubricate.

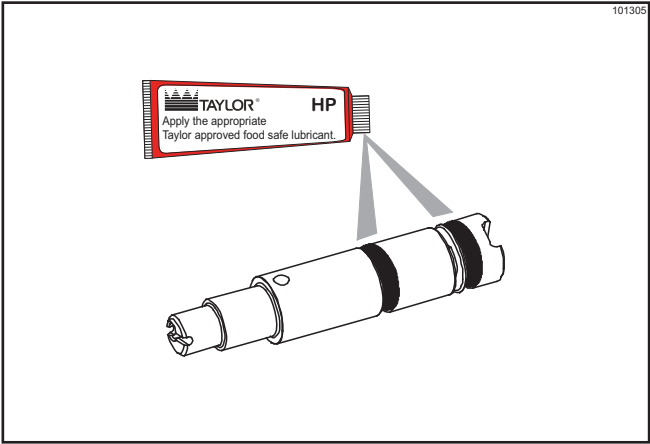

Figure 6-7

10. Turn the door upside down. Insert the draw valve spring.

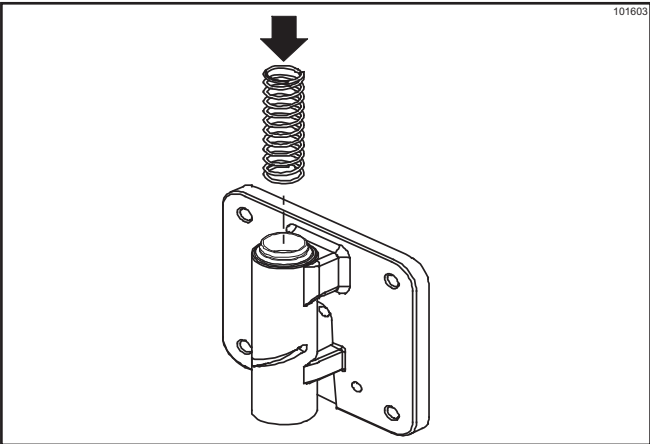

Figure 6-8

11. Insert the draw valve into the door. Line up the small hole on each side of the draw valve with the slot on each side of the door spout.

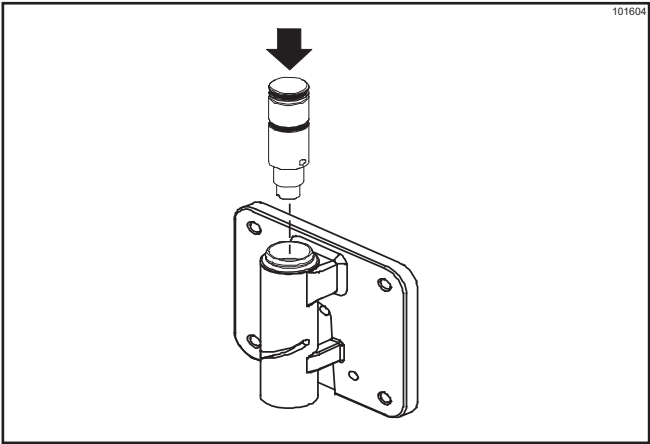

Figure 6-9

12. Apply firm downward pressure on the draw valve and center the draw valve hole in the small slot on the left side of the spout. Insert the draw valve handle through the slot and into the draw valve hole.

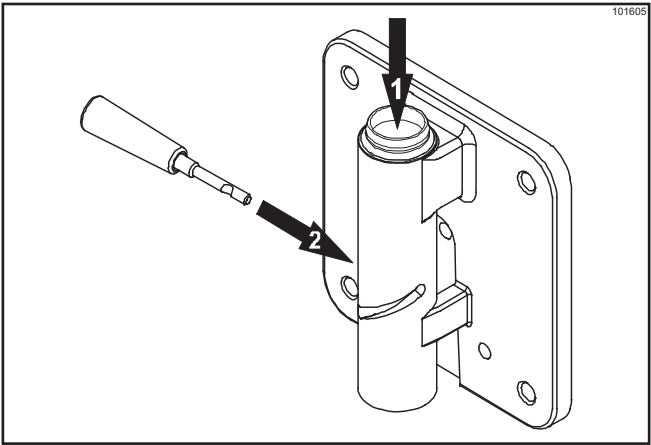

Figure 6-10

13. Move the draw handle to the forward position to allow installation of the ice buster.

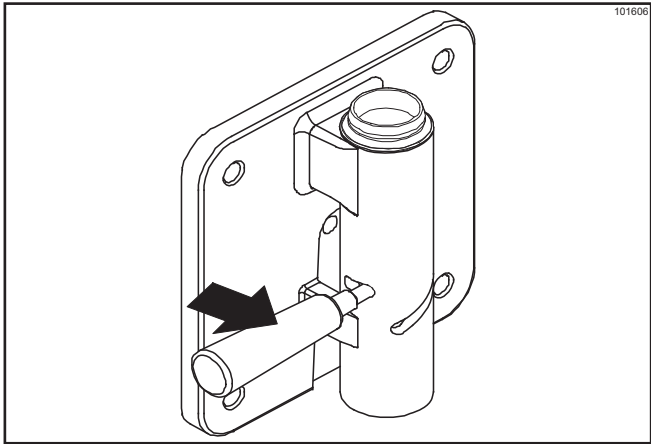

Figure 6-11

OPERATING PROCEDURES

14. From the back of the door, install the ice buster through the door spout and into the slot located just above the lower O-ring.

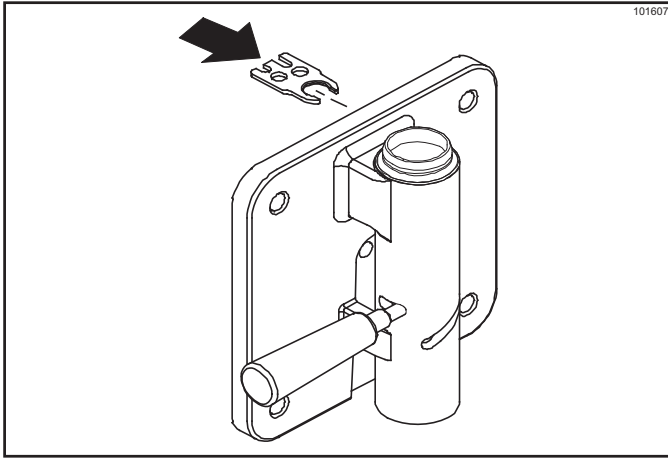

Figure 6-12

15. Move the draw handle to the back position to lock the ice buster in place.

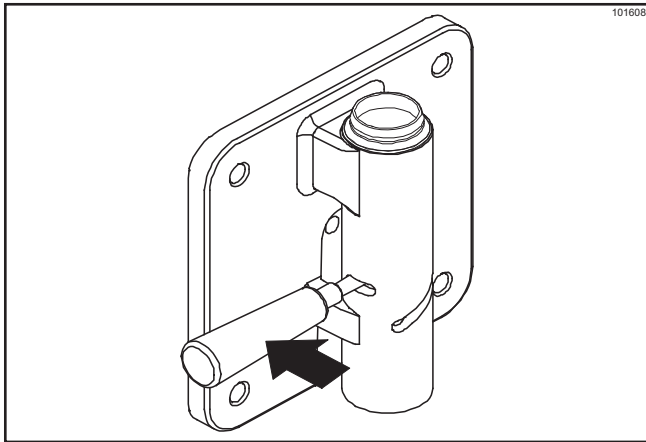

Figure 6-13

16. Turn the door right side up. Remove the draw valve handle. Install it on the other side, through the longer slot and into the draw valve hole.

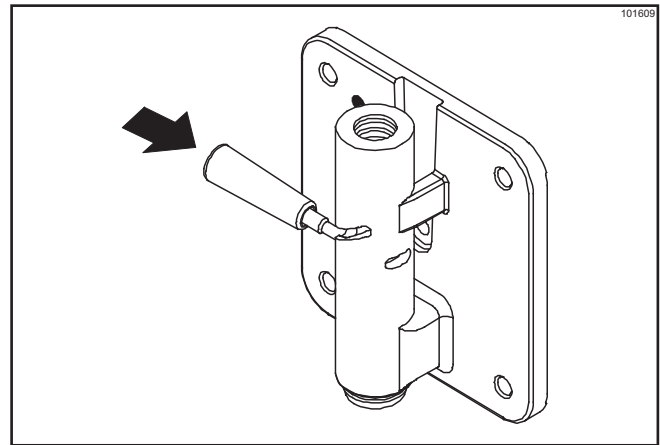

Figure 6-14

17. Insert the valve handle pin. Turn the pin and the draw valve handle until the pin drops completely into place.

Note: While turning the draw valve handle, it may be necessary to pull the draw valve handle back slightly to allow the pin to fall in place.

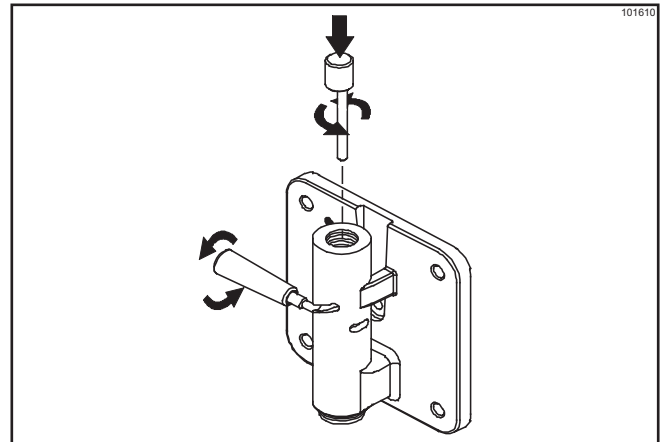

Figure 6-15

18. Place the O-ring onto the prime plug and lubricate.

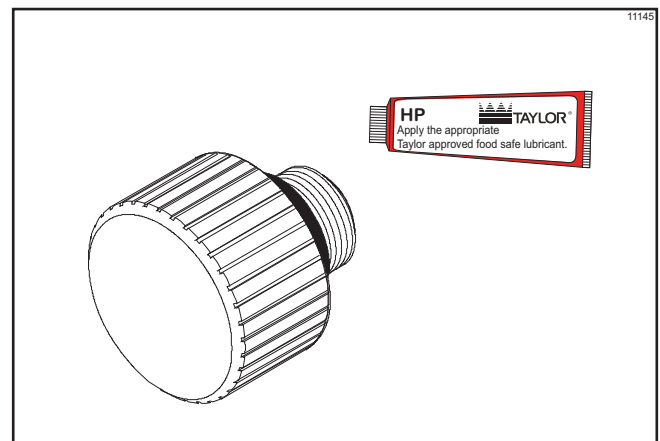

Figure 6-16

19. Screw the prime plug into position on the front of the door.

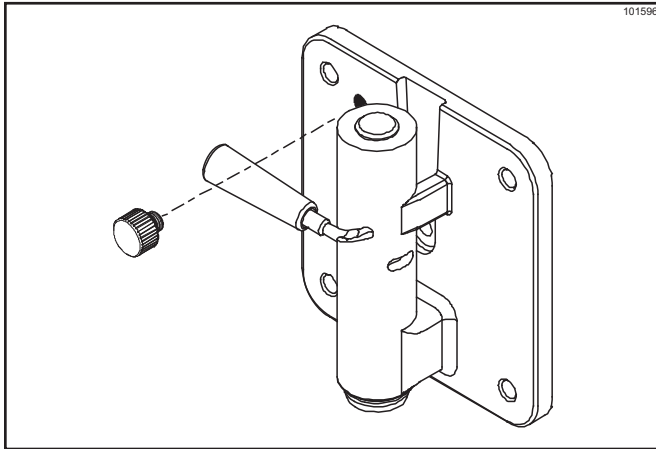

Figure 6-17

20. Place the large rubber gasket into the groove on the back side of the freezer door.

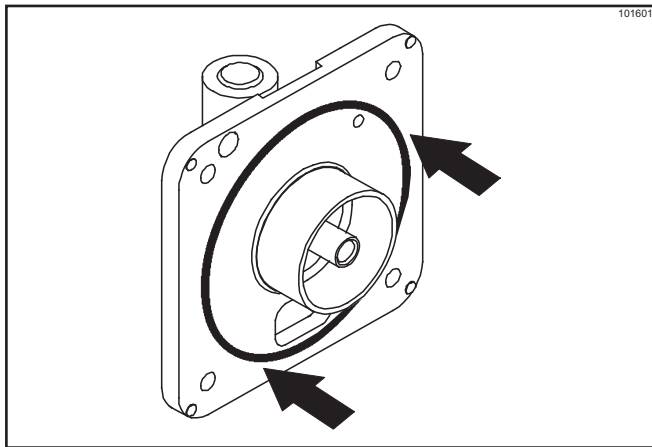

Figure 6-18

21. Slide the white, plastic front bearing onto the bearing hub, making sure that the flanged end of the bearing is resting against the freezer door. **Do not** lubricate the door gasket or front bearing.

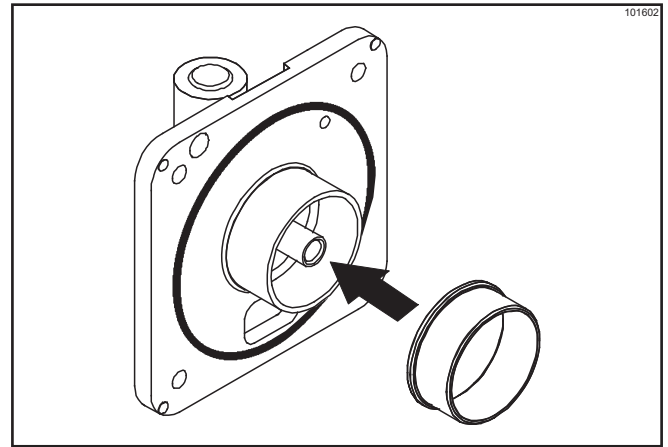

Figure 6-19

22. Position the freezer door onto the four studs on the front of the freezing cylinder and push the door into place. Install the four handscrews onto the studs and tighten them equally in a crisscross pattern to ensure that the door is secure. **Do not** overtighten the handscrews.

Note: If the freezer door does not fit into place easily, position the open end of the beater assembly in the 11 o'clock position.

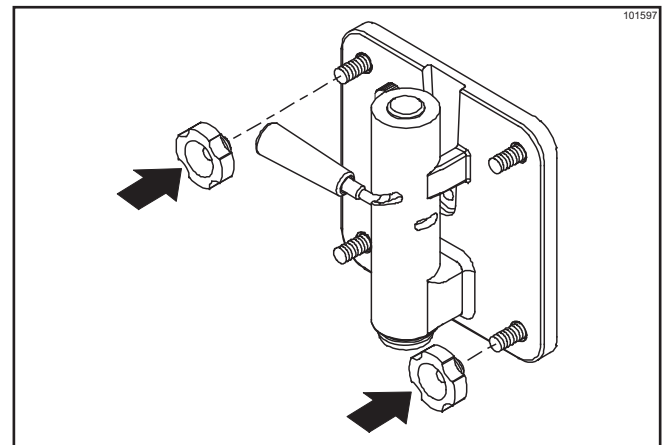

Figure 6-20

OPERATING PROCEDURES

23. Position the baffle arm by inserting it down into the hole on the baffle assembly that protrudes from the door. Verify proper installation by moving the baffle arm back and forth to make sure it moves freely.

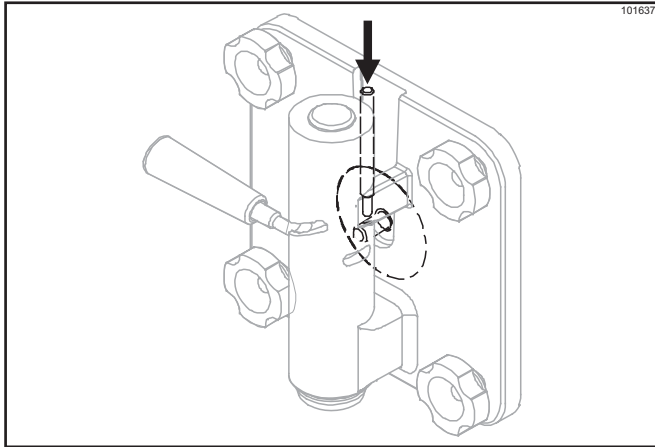

Figure 6-21

Repeat steps 1 through 23 for the remaining freezing cylinder(s).

Sanitizing

Note: If a machine is sanitized, and will not be used for an extended period of time, clean water should be used to flush all sanitizer from the lines. Remove the water from all the lines and components prior to storing the machine. Upon return to service, the machine must be sanitized prior to use.

1. Open the lighted display door. Place the control switch in the ON position.

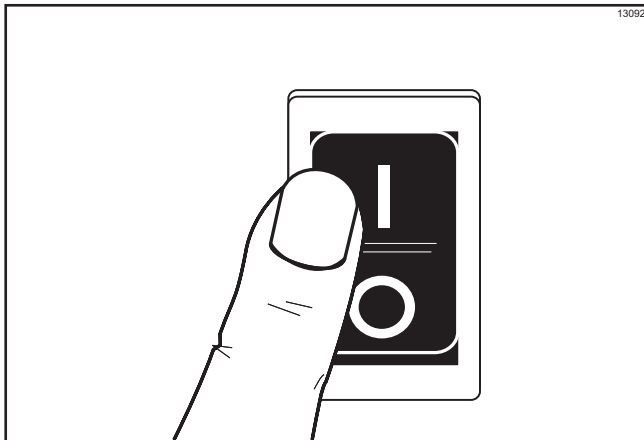

Figure 6-22

2. Prepare 2 gal. (7.6 L) of an approved 100 ppm sanitizing solution (examples: Stera-Sheen® or Kay-5®). Use warm water and follow the manufacturer's specifications.

Important! Make sure the sanitizer is completely dissolved.

3. Cut the syrup line connector from the end of an empty bag of syrup.

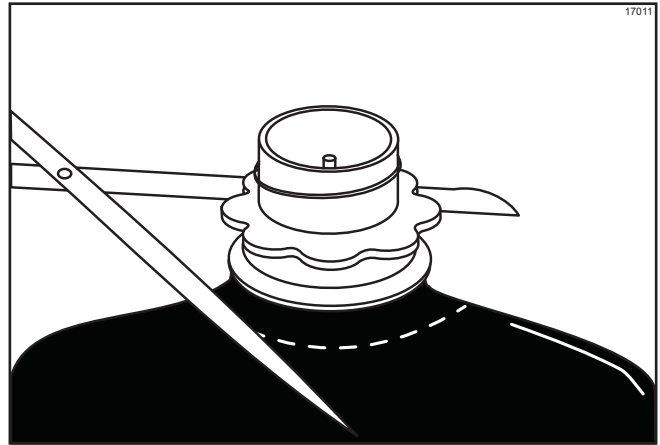

Figure 6-23

4. Connect the syrup line to the syrup line connector that was cut from the syrup bag.

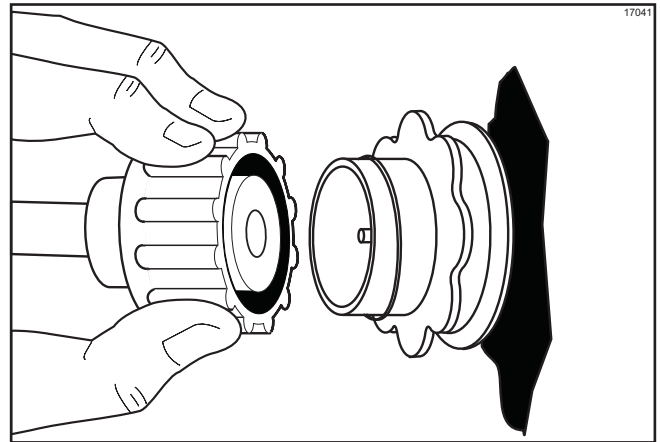

Figure 6-24

5. With the bag connector attached to the syrup line, place the syrup line into the pail of sanitizing solution.

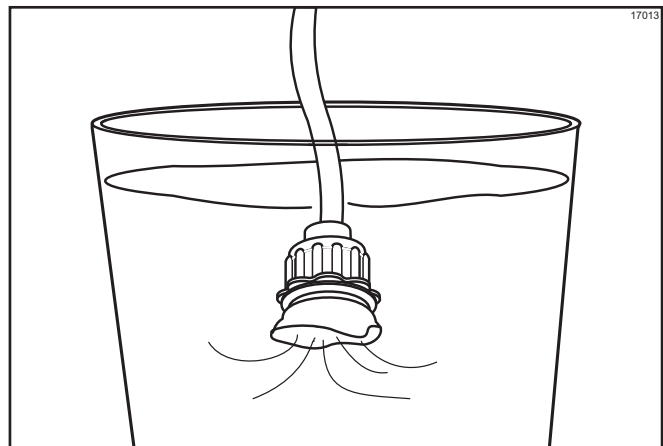
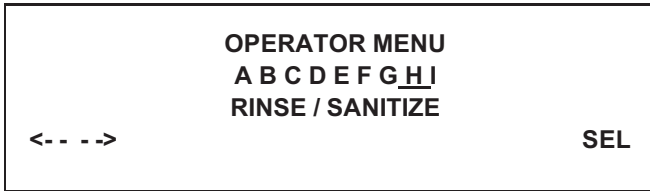

Figure 6-25

- To place the left freezing cylinder in the Sanitize mode, press the MENU (SEL) key. Move the cursor by pressing the AUTO (- ->) key until the third line indicates RINSE / SANITIZE.



Press the MENU (SEL) key.

Move the cursor under the word **SANITIZE** by pressing the OFF (<- -)key.

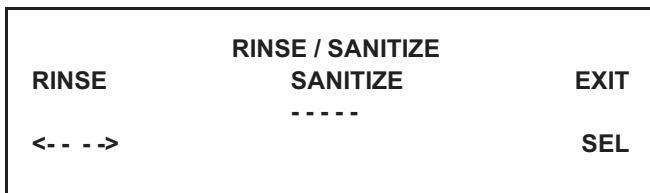

- Pressing the MENU (SEL) key will give you the option for sanitizing the left freezing cylinder. Move the cursor under the word "YES". Pressing the MENU (SEL) key at this time will start the flow of sanitizing solution into the left freezing cylinder.



- Repeat steps 6 and 7 for the right side freezing cylinder.



- Open the prime plugs. Place an empty pail under the door spouts. When sanitizing solution fills the freezing cylinders approximately 2/3 full, close the prime plugs.
- Continue filling the freezing cylinders with sanitizing solution until the solution purges out of the vent at the top of the mix tank and begins draining into the front drip tray. Press the OFF (<- -) key.

- Press the BEATER (- - -) key. Agitate the solution in the freezing cylinders for five minutes.

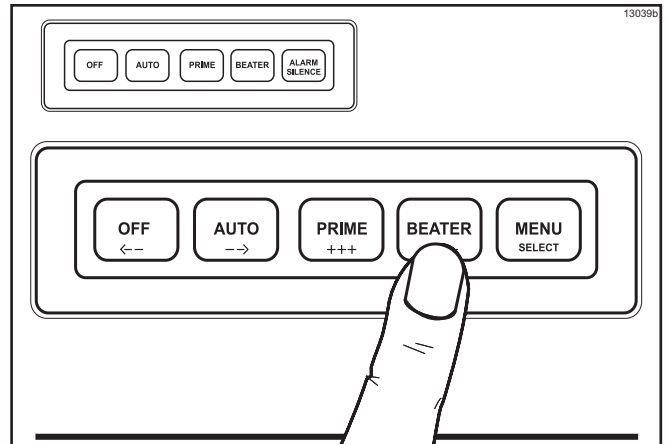

Figure 6-26

- With a pail beneath the door spouts, open the draw valves and drain all the solution from the freezing cylinders. Press the OFF (<- -) key and close the draw valves.

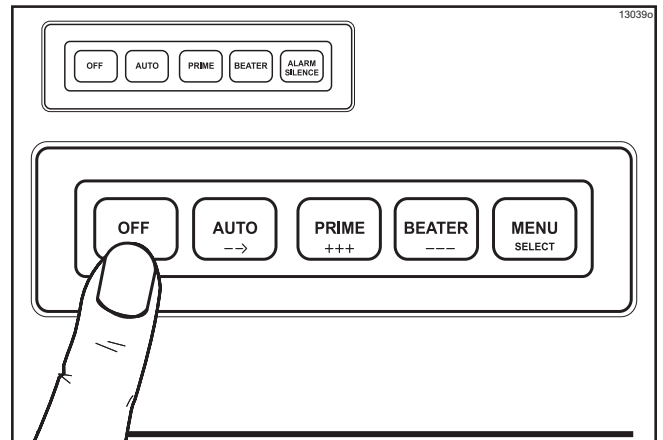

Figure 6-27



CAUTION! The machine must **NOT** be placed in Auto mode until all sanitizing solution has been removed from the freezing cylinder and proper priming procedures have been completed. Failure to follow this instruction may result in damage to the freezing cylinder.

- Disconnect the syrup connectors in the sanitizing solution.

Priming/Brixing

1. Connect the syrup line to the bag-in-box (BIB) syrup.
2. Remove the drip tray, splash shield, and lower front panel to gain access to the syrup sampling valves.
3. Open the prime plug.
4. Place the sampling valve in the OFF (center) position.

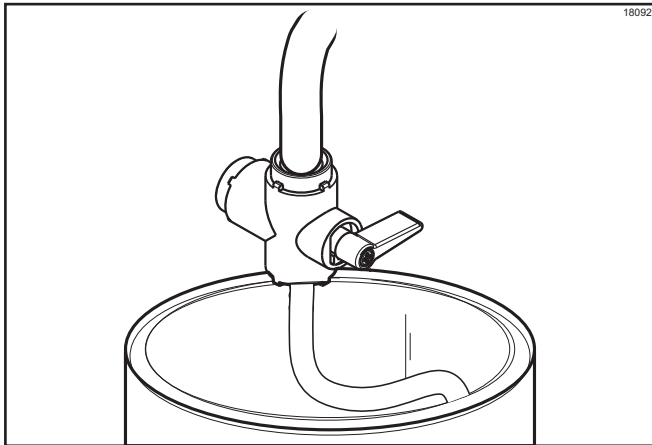

Figure 6-28

5. Press the PRIME (+ +) key.

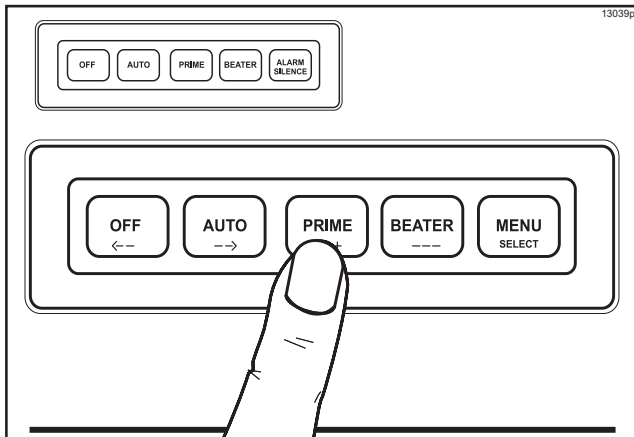

Figure 6-29

6. Slowly move the syrup sampling valve to the fully open position by turning the handle **down** toward the sampling line. Allow the liquid to run into a pail until all the sanitizer is removed and full-strength product is flowing.

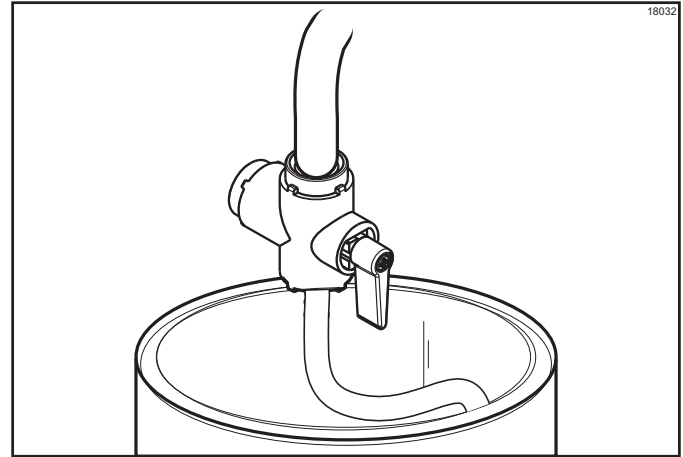

Figure 6-30

Important! Failure to remove all sanitizing solution may result in damage to the freezing cylinder.

Note: Brix is the ratio of syrup to water which will directly affect the quality and taste of the product. Brixing should be done before priming the freezer and when a change in syrup flavor has been made.

7. Pour the product from the syrup sampling valve into a cup. Close the syrup sampling valve by turning the handle to the center position.

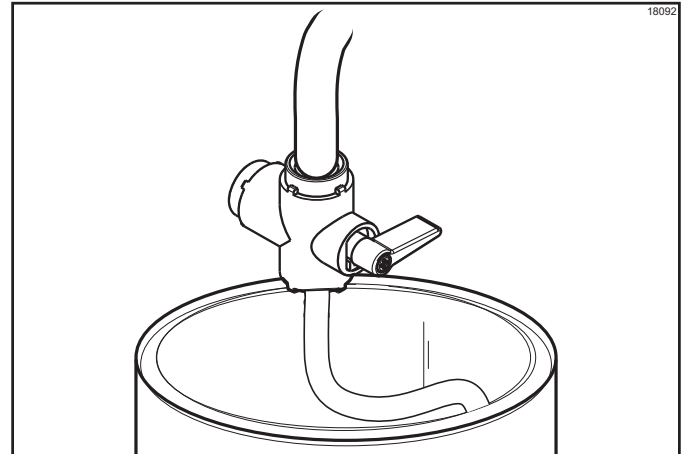

Figure 6-31

8. Stir the finished product. Pour a small amount of product over the refractometer. The brix reading should register 13 to 14. A reading higher than this would cause a darker, richer product. The refrigeration system would have to run longer to freeze this excess syrup. A reading lower than this could cause a freeze-up in the freezing cylinder because of the excess water.

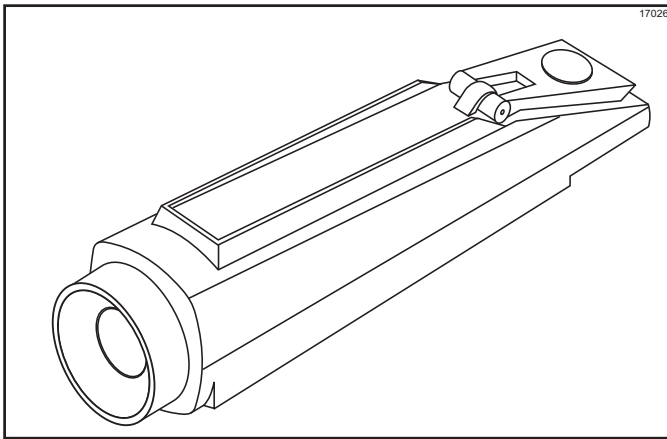

Figure 6-32

9. To adjust the brix, turn the adjustment screw located behind the drip tray shelf. Clockwise adjustments increase the amount of syrup to water, and counterclockwise adjustments decrease the amount of syrup to water. Adjust the screw in small increments and check the brix again.

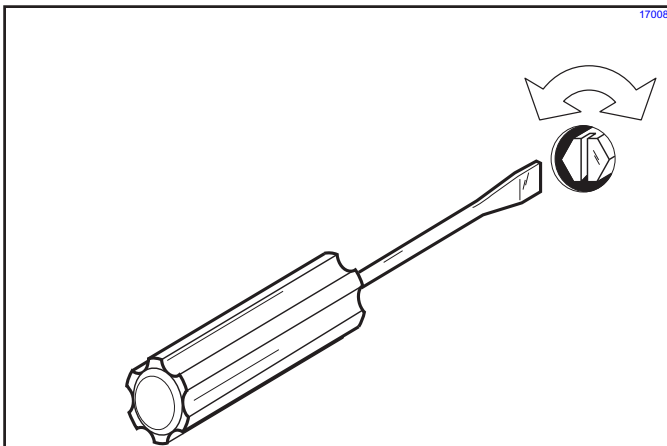

Figure 6-33

10. Repeat **steps** until a correct brix reading is registered.
11. Once the proper brix has been achieved, turn the handle **up** to allow product to flow to the mix tank.

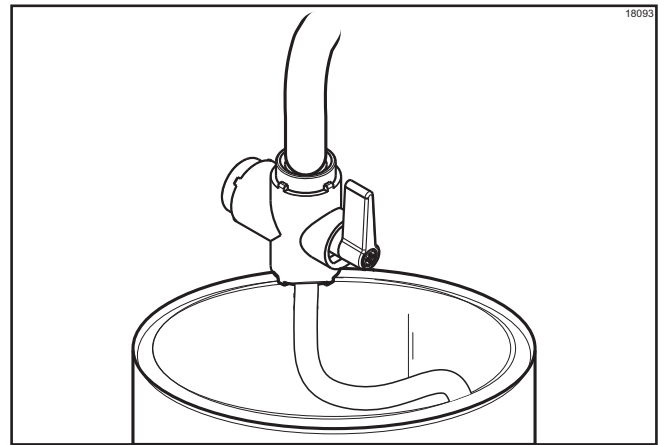

Figure 6-34

Note: The position of the handle on the syrup sampling valve determines the direction of product flow. The down position opens the syrup sampling valve for collecting brix samples. The center position shuts off the product flow. The up position directs the flow of product to the freezing cylinder.

12. Place a pail beneath the door spout. Open the draw valve and drain the freezing cylinder to remove any incorrectly brixed product. Close the draw valve.
13. Hold a large cup under the prime plug port on the door until the liquid level (not foam) reaches 1/4 in. to 3/8 in. (6 mm to 9 mm) below the prime hole. Press the OFF (<- -) key and then close the prime plug.
14. Press the BEATER (- - -) key. Let the machine run in the BEATER mode for 1 minute. Press the OFF (<- -) key.
15. Press the PRIME (+ + +) key. Allow the liquid level to fill to the prime plug hole
16. Repeat steps 1 through 15 for the other freezing cylinder.
17. To place the freezing cylinders in the Auto mode, press the AUTO (- ->) key on both sides. When the machine cycles off, the product will be at serving viscosity.

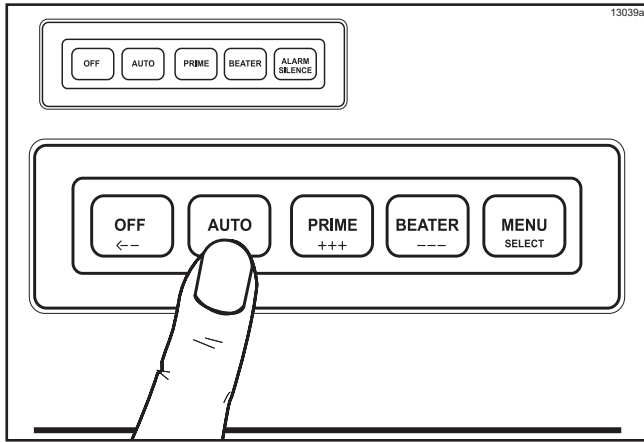

Figure 6-35

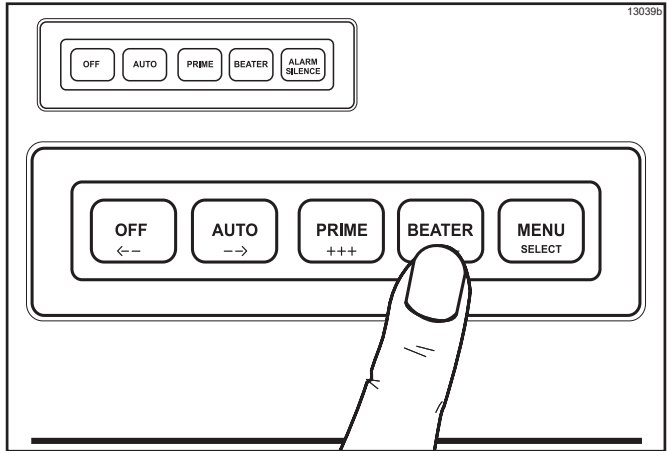

Figure 6-36

18. Close the lighted display when complete. Replace the panels and the hood, and attach with screws. Install the front drip tray and the splash shield on the front of the freezer.

2. When all the product has been drained from the freezing cylinder, close the draw valve and press the OFF (- -) key. Discard this product.

120 Day Closing Procedure

We recommend that the machine be completely disassembled and cleaned at least every 120 days.

ALWAYS FOLLOW LOCAL HEALTH CODES.

6

To disassemble the Model C300, the following items will be needed:

- Two cleaning pails
- Cleaning brushes (provided with freezer)
- Cleaner
- Single-service towels

Draining Product from the Freezing Cylinder

1. Press the BEATER (- - -) key. This will allow the beater to operate to push the product from the freezing cylinder. Open the draw valve and drain the product from the machine.

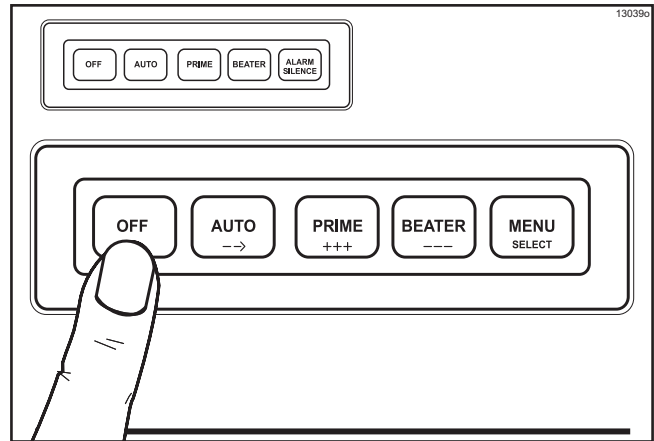

Figure 6-37

Repeat steps 1 and 2 for the other freezing cylinder.

Rinsing

1. To place the left cylinder in the Rinse mode, press the MENU (SEL) key. Move the cursor by pressing the AUTO (- ->) key until the third line indicates RINSE / SANITIZE.

OPERATOR MENU
A B C D E F G H I
RINSE / SANITIZE

<-- --> SEL

Press the MENU (SEL) key. Move the cursor under "RINSE" by pressing the OFF (- -) key twice.

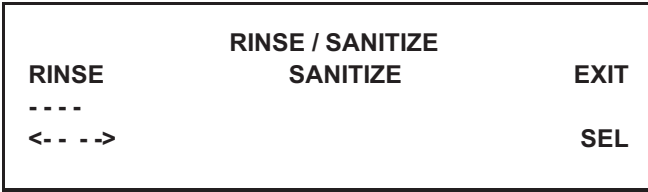

- Pressing the MENU (SEL) key will give you the option for rinsing the left freezing cylinder. Move the cursor under the word YES. Pressing the MENU (SEL) key at this time will start the beater motor and deliver water and CO₂ to the left cylinder.



- Allow the rinse water to flow into the cylinder until it is approximately 2/3 full. With a pail under the door spout, open the draw valve and drain the rinse water. Repeat this step until the rinse water being drawn is clear.
- Repeat steps 2 and 3 for the right side.



- When draining is complete, press the OFF (<- -) key.

Cleaning

- Prepare 1 gal. (7.6 L) of an approved cleaning solution (examples: Stera-Sheen® or Kay-5®). Use warm water and follow the manufacturer's specifications.

Important! Make sure the cleaner is completely dissolved.
- Pour the cleaning/sanitizing solution into a clean, empty pail. Place the syrup line with the old syrup connector into the pail of cleaner.
- To place the left freezing cylinder in the Sanitize mode, press the MENU (SEL) key. Move the cursor by pressing the AUTO (- ->) key until the third line indicates RINSE / SANITIZE. Press the MENU (SEL) key. Move the cursor under the word SANITIZE.

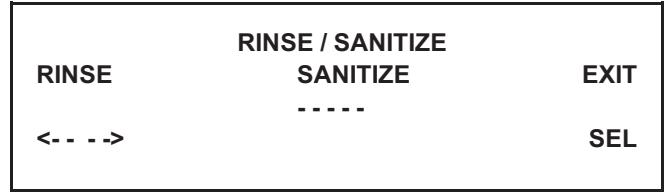

Pressing the MENU (SEL) key will give you the option to sanitize the left cylinder. Move the cursor under the word YES. Pressing the MENU (SEL) key at this time will start the flow of cleaner/sanitizer through the syrup system into the freezing cylinder.



- Repeat steps 1 through 3 for the right side freezing cylinder.
- Open the prime plugs. Allow each cylinder to fill approximately 2/3 full. Close each prime plug.
- Continue filling the freezing cylinders with sanitizing solution until the solution purges out of each vent, and begins draining into the front drip tray. The vents are located at the top of each mix tank. Press the OFF (<- -) key.
- Press the BEATER (- - -) key to agitate the solution in each freezing cylinder for 5 minutes.

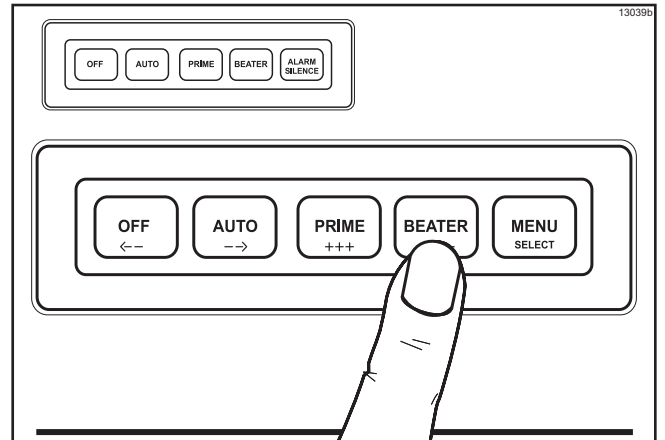

Figure 6-38

- With a pail beneath the door spouts, open the draw valves and drain all the solution from the freezing cylinders. Press the OFF (<- -) key and close the draw valves.

Disassembly



WARNING! Make sure the control switch is in the OFF position to eliminate the chance of moving parts. Failure to follow this instruction may result in severe personal injury from hazardous moving parts.

Remove the following parts from the freezer and take them to the sink for brush cleaning:

- Hand screws
- Freezer doors
- Baffle assemblies
- Beater assemblies and scraper blades
- Driveshafts
- Hopper covers
- Front drip tray
- Splash shield

Brush-Cleaning

1. Prepare a sink or a pail with an approved cleaning solution. Use warm water and follow the manufacturer's specifications (examples: Stera-Sheen® or Kay-5®).

6

Important! Follow the label directions. Too **strong** of a solution can cause parts damage, while too **mild** of a solution will not provide adequate cleaning. Make sure all brushes provided with the freezer are available for brush cleaning.

2. Return to the freezer with a small amount of cleaning solution. With a single-service towel, wipe clean the rear shell bearing surface. Brush-clean the rear shell bearings at the back of the freezing cylinders with the black bristle brush.

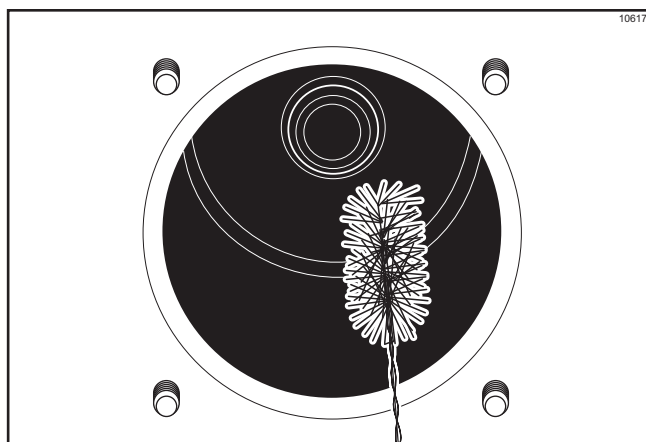

Figure 6-39

3. Remove the O-ring and seal from the driveshaft, and remove the O-ring and bearing from the baffle assembly.
4. From freezer door, remove the draw valve handle pin.
5. Turn the door upside down and install the draw handle on the other side of the door. Move the draw handle to the forward position to allow removal of the ice buster.

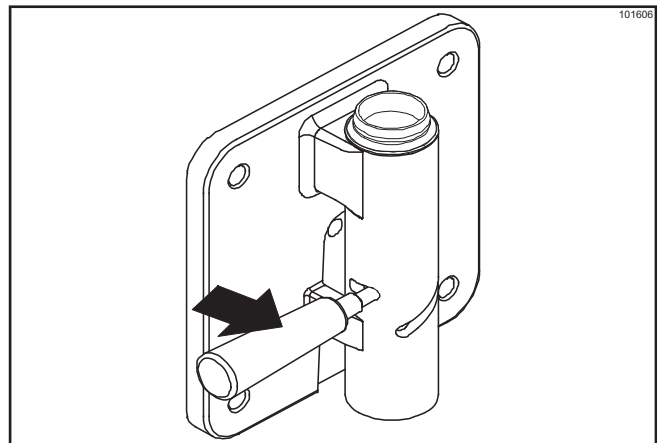

Figure 6-40

6. Remove the ice buster and prepare to remove the draw handle.

Important! The draw valve is under pressure from the spring. Apply downward pressure on the draw valve while removing the draw handle.
7. After the draw handle is removed, slowly release the pressure on the draw valve.
8. Remove the draw valve, spring, front bearing, and gasket. Remove all O-rings.
9. Discard all O-rings and replace them with new ones.

Note: To remove O-rings, use a single-service towel to grasp the O-ring, and apply pressure upward until the O-ring pops out of its groove. With the other hand, push the top of the O-ring forward until it rolls out of the groove and can be removed easily.
10. Thoroughly brush-clean all disassembled parts in the cleaning solution, making sure all lubricant and syrup is removed. Place all the cleaned parts on a clean, dry surface to air-dry.
11. Wipe clean all the exterior surfaces of the machine.

During Cleaning and Sanitizing



ALWAYS FOLLOW LOCAL HEALTH CODES.



NOTICE! Cleaning and sanitizing schedules are governed by your federal, state, or local regulatory agencies and must be followed accordingly. Please refer to the cleaning section of this manual for the proper procedure to clean this machine.

Note: We recommend cleaning and sanitizing every 120 days.

Troubleshooting Bacterial Count

- Thoroughly clean and sanitize the machine regularly, including complete disassembly and brush-cleaning.
- Use all brushes supplied for thorough cleaning. The brushes are specially designed to reach all product passageways
- Use the black bristle brush to thoroughly clean the rear shell bearing located at the rear of the freezing cylinder. Use a generous amount of cleaning solution on the brush.
- Using a screwdriver and a cloth towel, clean the rear shell bearing and the female hex drive socket of lubricant and product deposits.
- Properly prepare the cleaning and sanitizing solutions. Read and follow the label directions carefully. Too **strong** of a solution may damage the parts, and too **weak** of a solution will not do an adequate job of cleaning or sanitizing.
- Clean and sanitize the syrup lines regularly to prevent syrup residue buildup that would restrict the proper flow of syrup.
- On a regular basis, take a brix reading to ensure a consistent quality product.

Regular Maintenance Checks

- Replace scraper blades that are nicked, damaged, or worn down.
- Before installing the beater, make sure the scraper blades are properly attached over the pins.
- Check the rear shell bearing for signs of wear (excessive product leakage from the rear drip pans to the front drip tray).
- Dispose of O-rings or seals if they are worn, torn, or fit too loosely, and replace them with new ones.
- Follow all lubricating procedures as outlined in “Assembly” on page 6-1
- Check the condenser for dirt and lint. A dirty condenser will reduce the efficiency and capacity of the machine. The condenser should be cleaned monthly by removing and cleaning the poly-flo filter.

Winter Storage

If the place of business is to be closed during the winter months, it is important to protect the freezer by following certain precautions, particularly if the building is subject to freezing conditions.

Disconnect the freezer from the main power source to prevent possible electrical damage.

Your local Taylor distributor can perform this service for you.

Wrap detachable parts of the freezer such as the beater, scraper blades, driveshaft, and freezer door. Place these parts in a protected, dry place. Rubber trim parts and gaskets can be protected by wrapping them with moisture-proof paper. All parts should be thoroughly cleaned of dried mix or lubrication, which can attract mice and other vermin.

Note: It is recommended that a service technician perform winter storage draining, to ensure all water has been removed. This will guard against freezing and rupturing of the components.

Table 8-1

Problem	Probable cause	Remedy	Page ref
1. Product is too stiff.	a. Too much water to syrup ratio. Improper brix adjustment.	a. Adjust the brix accordingly.	6-8
	b. Consistency control needs adjustment.	b. Contact a service technician.	---
	c. Torque coupling bound in warm position.	c. Contact a service technician.	---
2. Product is too soft.	a. Freezer in a defrost cycle.	a. Wait for defrost cycle to end.	---
	b. Consistency control needs adjustment.	b. Contact a service technician.	---
	c. Torque coupling bound in cold position.	c. Contact a service technician.	---
	d. Broken springs in torque coupling.	d. Contact a service technician.	---
3. No product is being dispensed.	a. Product frozen-up in freezing cylinder.	a. See problem No. 1.	---
4. Freezer will not operate in the Beater or Auto modes.	a. Machine is unplugged.	a. Check the plug at wall receptacle.	---
	b. Blown fuse, or the circuit breaker is off.	b. Replace the fuse or turn the breaker on.	---
	c. Beater motor is out on overload. Check fault description screen.	c. Allow the motor to cool. Press the AUTO (- ->) key. Call a service technician if the beater motor goes out on overload again.	4-2
5. No compressor operation in the Auto mode.	a. Beater motor is out on overload. Check the fault description screen.	a. Allow the motor to cool. Press the AUTO (- ->) key. Call a service technician if the beater motor goes out on overload again.	4-2
	b. Condenser dirty, A/C.	b. Clean condenser monthly.	6-10
	c. Water supply off, W/C.	c. Turn the water on.	---
	d. The torque coupling is bound in the cold position.	d. Contact a service technician.	---
6. Unable to remove the driveshaft from the rear shell bearing.	a. Rounded corners of hex end of driveshaft, drive coupling, or both.	a. Replace the driveshaft, or call a service technician to replace the direct drive unit.	---
	b. Lubrication of hex end of driveshaft.	b. Do not lubricate the hex end. If necessary, contact a service technician for removal.	6-1

TROUBLESHOOTING GUIDE

Problem	Probable cause	Remedy	Page ref
7. The freezing cylinder walls are scored.	a. The scraper blades are damaged.	a. Replace the scraper blade.	6-2
	b. The front bearing is missing or worn.	b. Install or replace the front bearing.	6-1
	c. Machine was placed in Auto before all sanitizing solution was removed from freezing cylinder.	c. Place machine in Auto mode only after priming is complete and all sanitizing solution is removed.	6-8/6-10
	d. Broken pins on beater assembly.	d. Repair or replace the beater assembly. Make sure the scraper blades are properly seated on pins.	6-2
	e. The beater assembly is bent.	e. Call service technician to repair or replace the beater and to correct the cause of insufficient mix in the freezing cylinder.	---
8. Excessive loss of CO ₂ .	a. Leak in the CO ₂ system.	a. Contact a service technician.	---
9. Leakage from rear drip pan(s) into front drip tray.	a. Seal or O-ring on driveshaft is worn, missing, or incorrectly installed.	a. Replace or install correctly on driveshaft.	6-1
	b. Worn rear shell bearing.	b. Contact a service technician.	---
10. Excessive mix leakage from door spout.	a. Inadequate lubrication of draw valve O-rings.	a. Lubricate properly.	6-3
	b. Wrong type lubricant on draw valve O-rings.	b. Use food-grade lubricant (example: Taylor Lube HP).	6-1
	c. Worn or missing draw valve O-rings.	c. Replace or install O-rings on draw valve.	6-3 / 9-1
11. Unable to adjust brix.	a. Syrup lines need to be cleaned and sanitized.	a. Clean and sanitize syrup lines.	---
	b. Blocked flow control.	b. Contact a service technician.	---
12. Lack of syrup being supplied to machine.	a. Loss of CO ₂ to propel syrup.	a. Contact a service technician.	---
	b. Clogged or kinked syrup lines.	b. Sanitize syrup lines regularly. If kinked, repair or replace.	---

Table 9-1

Part Description	Every 4 Months	Every 8 Months	Annually
Scraper Blade		X	
Driveshaft Seal	X		
Driveshaft O-ring	X		
Freezer Door Gasket	X		
Draw Valve O-ring	X		
Front Bearing	X		
Prime Plug O-ring	X		
Black Bristle Brush, 1" x 2"		Inspect and replace if necessary.	Minimum
Double-Ended Brush		Inspect and replace if necessary.	Minimum
Brush, 1-1/2" x 2"		Inspect and replace if necessary.	Minimum
Brush, 3" x 7"		Inspect and replace if necessary.	Minimum

TAYLOR COMPANY LIMITED WARRANTY ON FREEZERS

Taylor Company, Inc. ("Taylor") is pleased to provide this limited warranty on new Taylor-branded freezer equipment available from Taylor to the market generally (the "Product") to the original purchaser only.

LIMITED WARRANTY

Taylor warrants the Product against failure due to defect in materials or workmanship under normal use and service as follows. All warranty periods begin on the date of original Product installation. If a part fails due to defect during the applicable warranty period, Taylor, through an authorized Taylor distributor or service agency, will provide a new or remanufactured part, at Taylor's option, to replace the failed defective part at no charge for the part. Except as otherwise stated herein, these are Taylor's exclusive obligations under this limited warranty for a Product failure. This limited warranty is subject to all provisions, conditions, limitations, and exclusions listed below and on the reverse (if any) of this document.

Table 10-1

Product	Part	Limited Warranty Period
Soft Serve	Insulated shell assembly	Five (5) years
Frozen Yogurt	Refrigeration compressor (except service valve)	Five (5) years
Shakes Smoothies	Beater motors	Two (2) years
Frozen Beverage	Beater drive gear	Two (2) years
Batch Desserts	Printed circuit boards and Softech controls beginning with serial number H8024200	Two (2) years
	Parts not otherwise listed in this table or excluded below	One (1) year

LIMITED WARRANTY CONDITIONS

1. If the date of original installation of the Product cannot be verified, then the limited warranty period begins ninety (90) days from the date of Product manufacture (as indicated by the Product serial number). Proof of purchase may be required at time of service.
2. This limited warranty is valid only if the Product is installed and all required service work on the Product is performed by an authorized Taylor distributor or service agency, and only if genuine, new Taylor parts are used.
3. Installation, use, care, and maintenance must be normal and in accordance with all instructions contained in the Taylor Operator's Manual.
4. Defective parts must be returned to the authorized Taylor distributor or service agency for credit.
5. The use of any refrigerant other than that specified on the Product's data label will void this limited warranty.

LIMITED WARRANTY EXCEPTIONS

This limited warranty does **not** cover:

1. Labor or other costs incurred for diagnosing, repairing, removing, installing, shipping, servicing, or handling of defective parts, replacement parts, or new Products.
2. Normal maintenance, cleaning and lubrication as outlined in the Taylor Operator's Manual, including cleaning of condensers.
3. Replacement of wear items designated as Class "000" parts in the Taylor Operator's Manual.

LIMITED WARRANTY ON EQUIPMENT

4. External hoses, electrical power supplies, and machine grounding.
5. Parts not supplied or designated by Taylor, or damages resulting from their use.
6. Return trips or waiting time required because a service technician is prevented from beginning warranty service work promptly upon arrival.
7. Failure, damage, or repairs due to faulty installation, misapplication, abuse, no or improper servicing, unauthorized alteration, or improper operation or use as indicated in the Taylor Operator's Manual, including but not limited to the failure to use proper assembly and cleaning techniques, tools, or approved cleaning supplies.
8. Failure, damage, or repairs due to theft, vandalism, wind, rain, flood, high water, water, lightning, earthquake, or any other natural disaster, fire, corrosive environments, insect or rodent infestation, or other casualty, accident or condition beyond the reasonable control of Taylor; operation above or below the electrical or water supply specification of the Product; or components repaired or altered in any way so as, in the judgment of the Manufacturer, to adversely affect performance, or normal wear or deterioration.
9. Any Product purchased over the Internet.
10. Failure to start due to voltage conditions, blown fuses, open circuit breakers, or damages due to the inadequacy or interruption of electrical service.
11. Electricity or fuel costs, or increases in electricity or fuel costs from any reason whatsoever.
12. Damages resulting from the use of any refrigerant other than that specified on the Product's data label will void this limited warranty.
13. Any cost to replace, refill, or dispose of refrigerant, including the cost of refrigerant.
14. **ANY SPECIAL, INDIRECT, OR CONSEQUENTIAL PROPERTY OR COMMERCIAL DAMAGE OF ANY NATURE WHATSOEVER.** Some jurisdictions do not allow the exclusion of incidental or consequential damages, so this limitation may not apply to you.

This limited warranty gives you specific legal rights, and you may also have other rights which vary from jurisdiction to jurisdiction.

LIMITATION OF WARRANTY

THIS LIMITED WARRANTY IS EXCLUSIVE AND IS IN LIEU OF ALL OTHER WARRANTIES, CONDITIONS, AND/OR REMEDIES UNDER THE LAW, INCLUDING ANY IMPLIED WARRANTIES OR CONDITIONS OF MERCHANTABILITY OR FITNESS FOR A PARTICULAR PURPOSE. THE ORIGINAL OWNER'S SOLE REMEDY WITH RESPECT TO ANY PRODUCTS SHALL BE REPAIR OR REPLACEMENT OF DEFECTIVE COMPONENTS UNDER THE TERMS OF THIS LIMITED WARRANTY. ALL RIGHTS TO CONSEQUENTIAL OR INCIDENTAL DAMAGES (INCLUDING CLAIMS FOR LOST SALES, LOST PROFITS, PRODUCT LOSS, PROPERTY DAMAGES, OR SERVICE EXPENSES) ARE EXPRESSLY EXCLUDED. THE EXPRESS WARRANTIES MADE IN THIS LIMITED WARRANTY MAY NOT BE ALTERED, ENLARGED, OR CHANGED BY ANY DISTRIBUTOR, DEALER, OR OTHER PERSON, WHATSOEVER.

LEGAL REMEDIES

The owner **must** notify Taylor in writing, by certified or registered letter to the following address, of any defect or complaint with the Product, stating the defect or complaint and a specific request for repair, replacement, or other correction of the Product under warranty, mailed at least thirty (30) days before pursuing any legal rights or remedies.

Taylor Company
750 N. Blackhawk Blvd.
Rockton, IL 61072, U.S.A.

TAYLOR COMPANY LIMITED WARRANTY ON TAYLOR GENUINE PARTS

Taylor Company, Inc. (“Taylor”) is pleased to provide this limited warranty on new Taylor genuine replacement components and parts available from Taylor to the market generally (the “Parts”) to the original purchaser only.

LIMITED WARRANTY

Taylor warrants the Parts against failure due to defect in materials or workmanship under normal use and service as follows. All warranty periods begin on the date of original installation of the Part in the Taylor unit. If a Part fails due to defect during the applicable warranty period, Taylor, through an authorized Taylor distributor or service agency, will provide a new or remanufactured Part, at Taylor’s option, to replace the failed defective Part at no charge for the Part. Except as otherwise stated herein, these are Taylor’s exclusive obligations under this limited warranty for a Part failure. This limited warranty is subject to all provisions, conditions, limitations, and exclusions listed below and on the reverse (if any) of this document.

Table 11-1

Parts Warranty Class Code or Part	Limited Warranty Period
Class 103 Parts ¹	Three (3) months
Class 212 Parts ²	Twelve (12) months
Class 512 Parts	Twelve (12) months No warranty
Class 000 Parts	No warranty

LIMITED WARRANTY CONDITIONS

1. If the date of original installation of the Part cannot be otherwise verified, proof of purchase may be required at time of service.
2. This limited warranty is valid only if the Part is installed and all required service work in connection with the Part is performed by an authorized Taylor distributor or service agency.
3. The limited warranty applies only to Parts remaining in use by their original owner at their original installation location in the unit of original installation.
4. Installation, use, care, and maintenance must be normal and in accordance with all instructions contained in the Taylor Operator’s Manual.
5. Defective Parts must be returned to the authorized Taylor distributor or service agency for credit.
6. This warranty is not intended to shorten the length of any warranty coverage provided pursuant to a separate Taylor Limited Warranty on freezer or grill equipment.
7. The use of any refrigerant other than that specified for the unit in which the Part is installed will void this limited warranty.

^{1, 2} Except that Taylor Part #032129SER2 (Compressor-Air-230V SERV) and Taylor Part #075506SER1 (Compressor-Air-115V 60HZ) shall have a limited warranty period of twelve (12) months when used in Taylor freezer equipment and a limited warranty period of two (2) years when used in Taylor grill equipment.

LIMITED WARRANTY ON PARTS

LIMITED WARRANTY EXCEPTIONS

This limited warranty does **not** cover:

1. Labor or other costs incurred for diagnosing, repairing, removing, installing, shipping, servicing, or handling of defective Parts, replacement Parts, or new Parts.
2. Normal maintenance, cleaning, and lubrication as outlined in the Taylor Operator's Manual, including cleaning of condensers or carbon and grease buildup.
3. Required service, whether cleaning or general repairs, to return the cooking surface assemblies, including the upper platen and lower plate, to an operational condition to achieve proper cooking or allow proper assembly of release sheets and clips as a result of grease buildup on the cooking surfaces, including but not limited to the platen and plate, sides of the shroud, or top of the shroud.
4. Replacement of cooking surfaces, including the upper platen and lower plate, due to pitting or corrosion (or in the case of the upper platen, due to loss of plating) as a result of damage due to the impact of spatulas or other small wares used during the cooking process or as a result of the use of cleaners, cleaning materials, or cleaning processes not approved for use by Taylor.
5. Replacement of wear items designated as Class "000" Parts in the Taylor Operator's Manual, as well as any release sheets and clips for the Product's upper platen assembly.
6. External hoses, electrical power supplies, and machine grounding.
7. Parts not supplied or designated by Taylor, or damages resulting from their use.
8. Return trips or waiting time required because a service technician is prevented from beginning warranty service work promptly upon arrival.
9. Failure, damage, or repairs due to faulty installation, misapplication, abuse, no or improper servicing, unauthorized alteration, or improper operation or use as indicated in the Taylor Operator's Manual, including but not limited to the failure to use proper assembly and cleaning techniques, tools, or approved cleaning supplies.
10. Failure, damage, or repairs due to theft, vandalism, wind, rain, flood, high water, water, lightning, earthquake, or any other natural disaster, fire, corrosive environments, insect or rodent infestation, or other casualty, accident or condition beyond the reasonable control of Taylor; operation above or below the gas, electrical or water supply specification of the unit in which a part is installed; or Parts or the units in which they are installed repaired or altered in any way so as, in the judgment of Taylor, to adversely affect performance, or normal wear or deterioration.
11. Any Part purchased over the Internet.
12. Failure to start due to voltage conditions, blown fuses, open circuit breakers, or damages due to the inadequacy or interruption of electrical service.
13. Electricity, gas, or other fuel costs, or increases in electricity or fuel costs from any reason whatsoever.
14. Damages resulting from the use of any refrigerant other than that specified for the unit in which the Part is installed will void this limited warranty.
15. Any cost to replace, refill, or dispose of refrigerant, including the cost of refrigerant.
16. **ANY SPECIAL, INDIRECT, OR CONSEQUENTIAL PROPERTY OR COMMERCIAL DAMAGE OF ANY NATURE WHATSOEVER.** Some jurisdictions do not allow the exclusion of incidental or consequential damages, so this limitation may not apply to you.

This limited warranty gives you specific legal rights, and you may also have other rights which vary from jurisdiction to jurisdiction.

LIMITATION OF WARRANTY

THIS LIMITED WARRANTY IS EXCLUSIVE AND IS IN LIEU OF ALL OTHER WARRANTIES, CONDITIONS, AND/OR REMEDIES UNDER THE LAW, INCLUDING ANY IMPLIED WARRANTIES OR CONDITIONS OF MERCHANTABILITY OR FITNESS FOR A PARTICULAR PURPOSE. THE ORIGINAL OWNER'S SOLEREMEDY WITH RESPECT TO ANY PRODUCTS SHALL BE REPAIR OR REPLACEMENT OF DEFECTIVE PARTS UNDER THE TERMS OF THIS LIMITED WARRANTY. ALL RIGHTS TO CONSEQUENTIAL OR INCIDENTAL DAMAGES (INCLUDING CLAIMS FOR LOST SALES, LOST PROFITS, PRODUCT LOSS, PROPERTY DAMAGES, OR SERVICE EXPENSES) ARE EXPRESSLY EXCLUDED. THE EXPRESS WARRANTIES MADE IN THIS LIMITED WARRANTY MAY NOT BE ALTERED, ENLARGED, OR CHANGED BY ANY DISTRIBUTOR, DEALER, OR OTHER PERSON, WHATSOEVER.

LEGAL REMEDIES

The owner **must** notify Taylor in writing, by certified or registered letter to the following address, of any defect or complaint with the Part, stating the defect or complaint and a specific request for repair, replacement, or other correction of the Part under warranty, mailed at least thirty (30) days before pursuing any legal rights or remedies.

Taylor Company
750 N. Blackhawk Blvd.
Rockton, IL 61072, U.S.A.

