

OPERATOR'S MANUAL



Model C606 Combination Freezer

Original Operating Instructions

059714-M

May, 2004 (Original Publication)
(Updated 8/5/2020)

Table of Contents

Section 1: To the Installer

Installer Safety	1-1
Site Preparation	1-1
Air-Cooled Machines	1-1
Water Connections	1-2
Electrical Connections	1-2
Beater Rotation	1-3
Refrigerant	1-4

Section 2: To the Operator

Section 3: Safety

Section 4: Operator Parts Identification

Exploded View	4-1
Front View	4-3
Syrup Cabinet View	4-5
Syrup Pump and Tubes	4-6
X57028-XX Pump A.—Mix Simplified - Shake	4-7
X57029-XX Pump A.—Mix Simplified - Soft Serve	4-8
X59304 Syrup Line Assembly—Thin Viscosity Syrup	4-9
X56652 Syrup Line Assembly—Thick Viscosity Shake Syrup (Optional)	4-10
X58450 Syrup Line Assembly—Syrup-in-Bag Option	4-11
Mix Hopper—Top View	4-12
Accessories	4-13
X44127 Brush Kit Assembly	4-15
X53800-BRN/TAN Syrup Pump	4-16
Beater Door Assembly—Shake Side	4-17
Beater Door Assembly—Soft Serve Side	4-19
059088 Parts Tray—Shake Side	4-20
059087 Parts Tray—Soft Serve Side	4-21
056525 Parts Tray—Simplified Pump	4-22

Section 5: User Interface

Symbol Definitions	5-2
Power Switch	5-2
Vacuum Fluorescent Display	5-2
Indicator Lights	5-2
Heat Cycle Key	5-2
Reset Mechanism	5-3
Air/Mix Pump Reset Mechanism	5-3
Adjustable Draw Handle	5-3

Table of Contents

Shake Fill Level Adjustment	5-3
VFD Screens	5-4
Manager's Menu	5-7

Section 6: Operating Procedures

Machine Setup	6-1
Sanitizing—Shake Side	6-11
Sanitizing—Soft Serve Side	6-13
Priming—Shake Side	6-14
Priming—Soft Serve Side	6-15
Daily Closing Procedures	6-15
Daily Opening Procedures	6-20
Syrup System	6-25
Syrup Topping Pump	6-27
Manual Brush Cleaning	6-32
Draining Product from the Freezing Cylinder	6-32
Rinsing	6-33
Cleaning and Sanitizing	6-34
Disassembly—Shake Side	6-34
Disassembly—Soft Serve Side	6-35
Brush Cleaning	6-36
Syrup System—Scheduled Maintenance	6-37

Section 7: Operator Checklist

During Cleaning and Sanitizing	7-1
Troubleshooting Bacterial Count	7-1
Regular Maintenance Checks	7-1
Winter Storage	7-2

Section 8: Troubleshooting Guide

Section 9: Parts Replacement Schedule

Section 10: Limited Warranty

Section 11: Limited Warranty on Parts

The following information has been included in the manual as safety and regulatory guidelines. For complete installation instructions, please see the Installation Checklist.

Installer Safety



IMPORTANT! In all areas of the world, machines should be installed in accordance with existing local codes. Please contact your local authorities if you have any questions.

Care should be taken to ensure that all basic safety practices are followed during the installation and servicing activities related to the installation and service of Taylor® machines.

- Only Taylor service personnel should perform installation, maintenance, and repairs on Taylor machines.
- Authorized service personnel should consult OSHA Standard 29CFR1910.147 or the applicable code of the local area for the industry standards on lockout/tagout procedures before beginning any installation or repairs.
- Authorized service personnel must ensure that the proper personal protective equipment (PPE) is available and worn when required during installation and service.
- Authorized service personnel must remove all metal jewelry, rings, and watches before working on electrical equipment.



DANGER! The main power supply(s) to the machine must be disconnected prior to performing any installation, maintenance, or repairs. Failure to follow this instruction may result in personal injury or death from electrical shock or hazardous moving parts, as well as poor performance or damage to the machine.



WARNING! This machine has many sharp edges that can cause severe injuries.

All repairs must be performed by an authorized Taylor service technician.

Site Preparation

Inspect the area where the machine will be installed before uncrating it. Make sure that all possible hazards to the user and the machine have been addressed.



WARNING! Only install this machine in a location where its use and maintenance is restricted to trained personnel. Failure to comply may result in personal injury.

Air-Cooled Machines

Do not obstruct air intake and discharge openings.

Air-cooled machines require a minimum of 3 in. (76 mm) of clearance around all sides to allow for adequate air flow across the condensers. Install the deflector provided to prevent recirculation of warm air. Failure to allow adequate clearance can reduce the refrigeration capacity and may cause permanent damage to the compressors.

For Indoor Use Only: This machine is designed to operate indoors under normal ambient temperatures of 70°F to 75°F (21°C to 24°C). The freezer has successfully performed in high ambient temperatures of 104°C (40°C) at reduced capacities.

Water Connections

(Water-Cooled Machines Only)

1 An adequate cold water supply must be provided with a hand shutoff valve. On the underside rear of the base pan, two 3/8 in. Iron Pipe Size (IPS) water connections for inlet and outlet have been provided for easy hookup. Permanently connect the machine using 1/2 in. (12.7 mm) inside diameter water lines. (Flexible lines are recommended, if local codes permit.) Depending on local water conditions, it may be advisable to install a water strainer to prevent foreign substances from clogging the automatic water valve. There will be only one water **in** and one water **out** connection. **Do not** install a hand shutoff valve on the water **out** line! Water should always flow in this order: first, through the automatic water valve; second, through the condenser; and third, through the outlet fitting to an **open trap drain**.



IMPORTANT! A backflow prevention device is required on the incoming water connection side. Please see the applicable national, state, and local codes for determining the proper configuration. Water pressure to the unit must not exceed 150 psi (1034 kPa).



WARNING! This machine must **NOT** be installed in an area where a water jet or hose can be used. **NEVER** use a water jet or hose to rinse or clean the machine. Failure to follow this instruction may result in electrocution.



CAUTION! This machine must be installed on a level surface to avoid the hazard of tipping. Extreme care should be taken in moving this machine for any reason. Two or more persons are required to safely move this machine. Failure to comply may result in personal injury or damage to the machine.

The authorized installer should inspect the machine for damage and promptly report any damage to the local authorized Taylor distributor.

This machine is made using USA hardware sizes. All metric conversions are approximate.

Electrical Connections

In the United States, this machine is intended to be installed in accordance with the National Electrical Code (NEC), ANSI/NFPA 70-1987. The purpose of the NEC code is the practical safeguarding of persons and property from hazards arising from the use of electricity. This code contains provisions considered necessary for safety. In all other areas of the world, machine should be installed in accordance with the existing local codes. Please contact your local authorities.



FOLLOW YOUR LOCAL ELECTRICAL CODES.

Each machine requires one power supply for each data label on the machine. Check the data label(s) on the freezer for branch circuit overcurrent protection or fuse, circuit ampacity, and other electrical specifications. See the wiring diagram provided inside the electrical box for proper power connections.



IMPORTANT! An equipotential grounding lug is provided with this machine. Some countries require the grounding lug to be properly attached to the rear of the frame by the authorized installer. The installation location is marked by the equipotential bonding symbol (5021 of IEC 60417-1) on both the removable panel and the machine's frame.



WARNING! This machine must be properly grounded. Failure to do so can result in severe personal injury from electrical shock.



WARNING! Avoid injury.

- **DO NOT** operate the machine unless it is properly grounded.
- **DO NOT** operate the machine with larger fuses than specified on the machine's data label.
- All repairs should be performed by an authorized Taylor service technician.
- The main power supplies to the machine must be disconnected prior to performing installation, repairs, or maintenance.

- **For Cord-Connected Machines:** Only authorized Taylor service technicians or licensed electricians may install a plug or replacement cord on the machine.
- Machines that are permanently connected to fixed wiring and for which leakage currents may exceed 10 mA, particularly when disconnected or not used for long periods, or during initial installation, shall have protective devices to protect against the leakage of current, such as a GFI, installed by the authorized personnel to the local codes.
- Stationary machines which are not equipped with a power cord and a plug or another device to disconnect the appliance from the power source must have an all-pole disconnecting device with a contact gap of at least 0.125 in. (3 mm) installed in the external installation.
- Supply cords used with this machine shall be oil-resistant, sheathed flexible cable not lighter than ordinary polychloroprene or other equivalent synthetic elastomer-sheathed cord (code designation 60245 IEC 57) installed with the proper cord anchorage to relieve conductors from strain, including twisting, at the terminals and protect the insulation of the conductors from abrasion.
- If the supply cord is damaged, it must be replaced by an authorized Taylor service technician in order to avoid a hazard.
- Secure the supply cord ground lead to the machine in a location where if the cord is pulled, the main power leads will become taut before the ground lead can break loose.

Failure to follow these instructions may result in electrocution. Contact your local authorized Taylor distributor for service.



IMPORTANT!

- *Stationary machines which are not equipped with a power cord and a plug or another device to disconnect the machine from the power source must have an all-pole disconnecting device with a contact gap of at least 0.125 in. (3 mm) installed in the external installation.*
- *Machines that are permanently connected to*

fixed wiring and for which leakage currents may exceed 10 mA, particularly when disconnected or not used for long periods, or during initial installation, shall have protective devices to protect against the leakage of current, such as a GFI, installed by the authorized personnel to the local codes.

- *Supply cords used with this machine shall be oil-resistant, sheathed flexible cable not lighter than ordinary polychloroprene or other equivalent synthetic elastomer-sheathed cord (code designation 60245 IEC 57) installed with the proper cord anchorage to relieve conductors from strain, including twisting, at the terminals and protect the insulation of the conductors from abrasion.*
- *If the supply cord is damaged, it must be replaced by an authorized Taylor service technician in order to avoid a hazard.*
- *Secure the supply cord ground lead to the machine in a location where if the cord is pulled, the main power leads will become taut before the ground lead can break loose.*

1

Beater Rotation



NOTICE! Beater rotation must be clockwise as viewed looking into the freezing cylinder.

To correct the rotation on a three-phase machine, interchange any two incoming power supply lines at the freezer main terminal block only. To correct rotation on a single-phase machine, exchange leads inside the beater motor. (Follow the diagram printed on the motor.)

Electrical connections are made directly to the terminal block provided in the main control box located behind the service panel.

It is recommended that beater rotation adjustment be performed by an authorized Taylor service technician.

Refrigerant



CAUTION! This machine contains fluorinated greenhouse gases (F-Gas) to provide refrigeration using a hermetically sealed circuit or within foam insulation.

This machine's type of gas, quantity, Global Warming Potential (GWP), and CO₂ tonnes equivalent information is recorded on the machine's data-label. The refrigerant used is generally considered nontoxic and nonflammable. However any gas under pressure is potentially hazardous and must be handled with caution.

NEVER fill any refrigerant cylinder completely with liquid. Filling the cylinder to approximately 80% will allow for normal expansion.



CAUTION! Use only approved refrigerant listed on the machine's data label or authorized through a manufacturer's technical bulletin. The use of any other refrigerant may expose users and operators to unexpected safety hazards.



WARNING! Refrigerant liquid sprayed onto the skin may cause serious damage to tissue. Keep eyes and skin protected. If refrigerant burns should occur, flush the area immediately with cold water. If burns are severe, apply ice packs and contact a physician immediately.



NOTICE! Taylor reminds technicians to be aware of and in compliance with local government laws regarding refrigerant recovery, recycling, and reclaiming systems. For information regarding applicable local laws, please contact your local authorized Taylor distributor.



IMPORTANT! *Refrigerants and their associated lubricants may be extremely moisture absorbent. When opening a refrigeration system, the maximum time the system is open must not exceed 15 minutes. Cap all open tubing to prevent humid air or water from being absorbed by the oil.*

The freezer you have purchased has been carefully engineered and manufactured to give you dependable operation. The Model C606, when properly operated and cared for, will produce a consistent quality product. Like all machines, it will require cleaning and maintenance. A minimum amount of care and attention is necessary if the operating procedures outlined in this manual are followed closely.

This Operator's Manual should be read before operating or performing any maintenance on the machine.

Your Taylor freezer will **not** eventually compensate and correct for any errors during the setup or filling operations. Thus, the initial assembly and priming procedures are of extreme importance. It is strongly recommended that all personnel responsible for the machine's operation thoroughly read and understand this manual.

If you require technical assistance, please contact your local authorized Taylor distributor.

Note: *Your Taylor warranty is valid only for authorized Taylor parts purchased from an authorized Taylor distributor, and for required service work provided by an authorized Taylor service technician. Taylor reserves the right to deny warranty claims on machines or parts if unapproved parts or incorrect refrigerant were installed in the machine, system modifications were performed beyond factory recommendations, or it is determined that the failure was caused by abuse, misuse, neglect, or failure to follow all operating instructions. For full details of your Taylor warranty, please see the Limited Warranty section in this manual.*

Note: *Constant research results in steady improvements; therefore, information in this manual is subject to change without notice.*



IMPORTANT! *If the crossed-out wheeled-bin symbol is affixed to this machine, it signifies that this machine is compliant with the EU Directives as well as other similar end-of-life legislation in effect after August 13, 2005. Therefore, it must be collected separately after its use is completed and cannot be disposed as unsorted municipal waste.*

The user is responsible for delivering the machine to the appropriate collection facility, as specified by your local code.

For additional information regarding applicable local disposal laws, please contact the municipal waste facility and/or local authorized Taylor distributor.

Compressor Warranty Disclaimer

2 The refrigeration compressor(s) on this machine are warranted for the term stated in the Limited Warranty section in this manual. However, due to the Montreal Protocol and the U.S. Clean Air Act Amendments of 1990, many new refrigerants are being tested and developed, thus seeking their way into the service industry. Some of these new refrigerants are being advertised as drop-in replacements for numerous applications. It should be noted that in the event of ordinary service to this machine's refrigeration system, **only the refrigerant specified on the affixed data label should be used.** The unauthorized use of alternate refrigerants will void your Taylor compressor warranty. It is the machine owner's responsibility to make this fact known to any technicians they employ.

It should be noted that Taylor does not warrant the refrigerant used in its machine. For example, if the refrigerant is lost during the course of ordinary service to this machine, Taylor has no obligation to either supply or provide its replacement either at billable or unbillable terms. Taylor does have the obligation to recommend a suitable replacement if the original refrigerant is banned, obsolete, or no longer available during the 5-year warranty of the compressor.

Taylor will continue to monitor the industry and test new alternates as they are being developed. Should a new alternate prove, through our testing, that it would be accepted as a drop-in replacement, then the above disclaimer would become null and void.

To find out the current status of an alternate refrigerant as it relates to your compressor warranty, call the local Taylor distributor or the Taylor factory. Be prepared to provide the model and serial number of the machine in question.

For Units Equipped with Taylor's Remote Monitoring System

FCC / IC ID Label Placement:

- This hardware installation package includes a label that must be placed on the unit immediately after the installation of the IoT hardware device has been completed.
- The label indicates the FCC ID and Industry Canada ID for the wireless communication device. The label must be placed on the outside surface of the machine, in a manner that is visible and unobstructed.
- It is recommended that this label be placed directly adjacent to the product nameplate of this device.

FCC Compliance Statement:

- This equipment has been tested and found to comply with the limits for a Class A digital device, pursuant to part 15 of the FCC Rules.
- These limits are designed to provide reasonable protection against harmful interference when the equipment is operated in a commercial environment.
- This equipment generates, uses, and can radiate radio frequency energy, and if not installed and used in accordance with the instruction manual, may cause harmful interference to radio communications.
- Operation of this equipment in a residential area is likely to cause harmful interference, in which case the user will be required to correct the interference at his own expense.

Industry Canada Statement:

- This device complies with Industry Canada license-exempt RSS standard(s).
- Operation is subject to the following two conditions:
 - a. This device may not cause interference.
 - b. This device must accept any interference, including interference that may cause undesired operation of this device.

We at Taylor are concerned about the safety of the operator when they come in contact with the freezer and its parts. Taylor has gone to extreme efforts to design and manufacture built-in safety features to protect both operator and service technician. As an example, warning labels have been attached to the freezer to further point out safety precautions to the operator.



DANGER! Failure to adhere to the following safety precautions may result in severe personal injury or death. Failure to comply with these warnings may also damage the machine and/or its components. Such damage may require component replacement and service repair expenses.



NOTICE! DO NOT operate this machine without reading this entire manual first. Failure to follow all of these operating instructions may result in damage to the machine, poor performance, health hazards, or personal injury.



IMPORTANT! *This machine is to be used only by trained personnel. It is not intended for use, cleaning, or maintenance by children or people with reduced physical, sensory, or mental capabilities or lack of experience and knowledge, unless given supervision or instruction concerning the use of the machine by a person responsible for their safety. Children should be supervised to ensure that they do not play with the machine.*



IMPORTANT! *An equipotential grounding lug is provided with this machine. Some countries require the grounding lug to be properly attached to the rear of the frame by the authorized installer. The installation location is marked by the equipotential bonding symbol (5021 of IEC 60417-1) on both the removable panel and the machine's frame.*



WARNING! Avoid injury.

- **DO NOT** operate the machine unless it is properly grounded.
- **DO NOT** operate the machine with larger fuses than specified on the machine's data label.
- All repairs should be performed by an authorized Taylor service technician.
- The main power supplies to the machine must be disconnected prior to performing installation, repairs, or maintenance.
- **For Cord-Connected Machines:** Only authorized Taylor service technicians or licensed electricians may install a plug or replacement cord on the machine.
- Machines that are permanently connected to fixed wiring and for which leakage currents may exceed 10 mA, particularly when disconnected or not used for long periods, or during initial installation, shall have protective devices to protect against the leakage of current, such as a GFI, installed by the authorized personnel to the local codes.
- Stationary machines which are not equipped with a power cord and a plug or another device to disconnect the appliance from the power source must have an all-pole disconnecting device with a contact gap of at least 0.125 in. (3 mm) installed in the external installation.
- Supply cords used with this machine shall be oil-resistant, sheathed flexible cable not lighter than ordinary polychloroprene or other equivalent synthetic elastomer-sheathed cord (code designation 60245 IEC 57) installed with the proper cord anchorage to relieve conductors from strain, including twisting, at the terminals and protect the insulation of the conductors from abrasion.
- If the supply cord is damaged, it must be replaced by an authorized Taylor service technician in order to avoid a hazard.
- Secure the supply cord ground lead to the machine in a location where if the cord is pulled, the main power leads will become taut before the ground lead can break loose.

SAFETY

Failure to follow these instructions may result in electrocution. Contact your local authorized Taylor distributor for service.



WARNING! Avoid injury.

- **DO NOT** allow untrained personnel to operate this machine.
- **DO NOT** operate the machine unless all service panels and access doors are fastened with screws.
- **DO NOT** remove any internal operating parts (including, but not limited to, freezer door, beater, or scraper blades) unless all control switches are in the OFF position.

3

Failure to follow these instructions may result in severe personal injury, especially to fingers or hands, from hazardous moving parts.



WARNING! This machine has many sharp edges that can cause severe injuries.

- **DO NOT** put objects or fingers near the shaver or the pitcher blades.
- **USE EXTREME CAUTION** when removing blades that are very sharp.

Failure to follow this instruction may result in contaminated product or personal injury from blade contact.



IMPORTANT! Access to the service area of the machine is restricted to persons having knowledge and practical experience with the machine, in particular as far as safety and hygiene are concerned.



NOTICE! Cleaning and sanitizing schedules are governed by your federal, state, or local regulatory agencies and must be followed accordingly. Please refer to the cleaning section of this manual for the proper procedure to clean this machine.



WARNING! This machine must **NOT** be installed in an area where a water jet or hose can be used. **NEVER** use a water jet or hose to rinse or clean the machine. Failure to follow this instruction may result in electrocution.



CAUTION! This machine is equipped with a refrigerated cabinet, designed to maintain product temperature at or below 41°F (5°C). Before replenishing the mix supply, the product must be refrigerated at or below 41°F (5°C). Failure to follow this instruction may result in health hazards and poor freezer performance.

DO NOT run the machine without product. Failure to follow this instruction can result in damage to the machine.

DO NOT obstruct air intake and discharge openings. A minimum of 3 in. (76 mm) air clearance on both sides of the machine is required. It is recommended to place the rear of the machine against the wall to prevent the recirculation of warm air. Failure to follow this instruction may cause poor freezer performance and damage to the machine.

For Indoor Use Only: This machine is designed to operate indoors, under normal ambient temperatures of 70°F to 75°F (21°C to 24°C). The machine has successfully performed in high ambient temperatures of up to 104°F (40°C) at reduced capacities.

Noise Level: Airborne noise emission does not exceed 78 dB(A) when measured at a distance of 39 in. (1.0 m) from the surface of the machine and at a height of 62 in. (1.6 m) from the floor.

Section 4

Operator Parts Identification

Exploded View

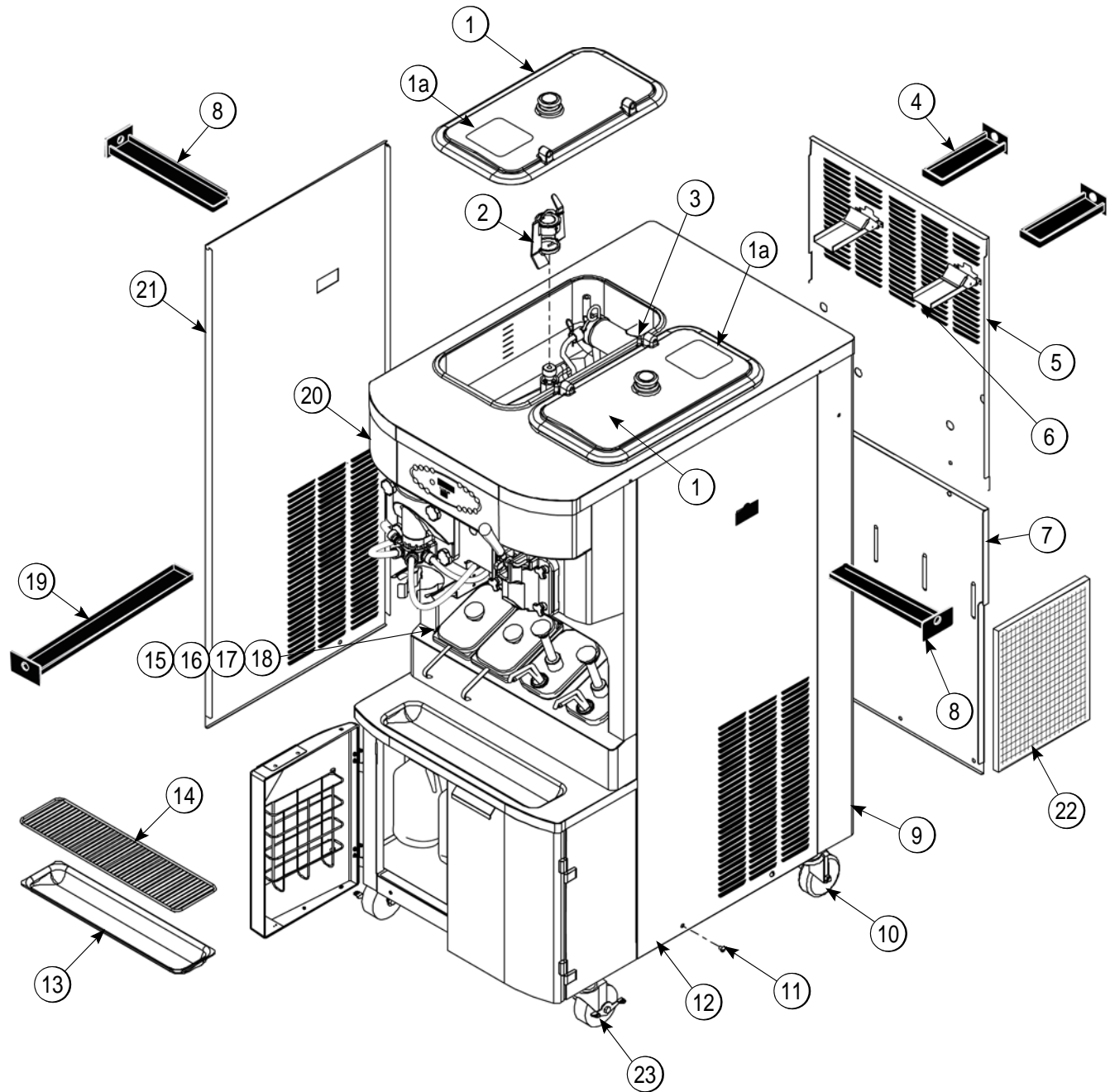

4

Figure 4-1

OPERATOR PARTS IDENTIFICATION

Exploded View

Item	Description	Part No.
1	Kit A.-Cover-Hopper	X65368-SP
1a	Label-Caution-Agitator	045191
2	Agitator A.-Mix Hopper-20	X44797
3	Pin-Retaining Hopper CVR	043934
4	Pan-Drip-Rear	X56003
5	Panel-Rear-Upper	066724
6	Guide A.-Drip Pan-Mix Pump	X48228
7	Panel-Rear-Lower	055959
8	Pan-Drip-Side	X56005
9	Trim-Corner-Rear-R	056692
	Trim-Corner-Rear-L	056693
10	Caster-4"	044106
11	Screw-1/4-20X3/8	011694

Item	Description	Part No.
12	Panel-Side Right	055950
13	Tray-Drip	033812
14	Shield-Splash	033813
15	Lid-Syrup Jar	042706
16	Jar-Syrup*Plastic	036573
17	Jar-Syrup*Stainless	036574
18	Ladle-1 oz	033637-1
19	Pan-Drip 19-1/2 Long	035034
20	Plate-DEC	056131-1
21	Panel-Side Left	055957
22	Filter-Air-18.00LX13.50HX.70	052779-3
23	Caster-4" SWV 3/4-10 Stem w/ Brake	046437

4

Front View

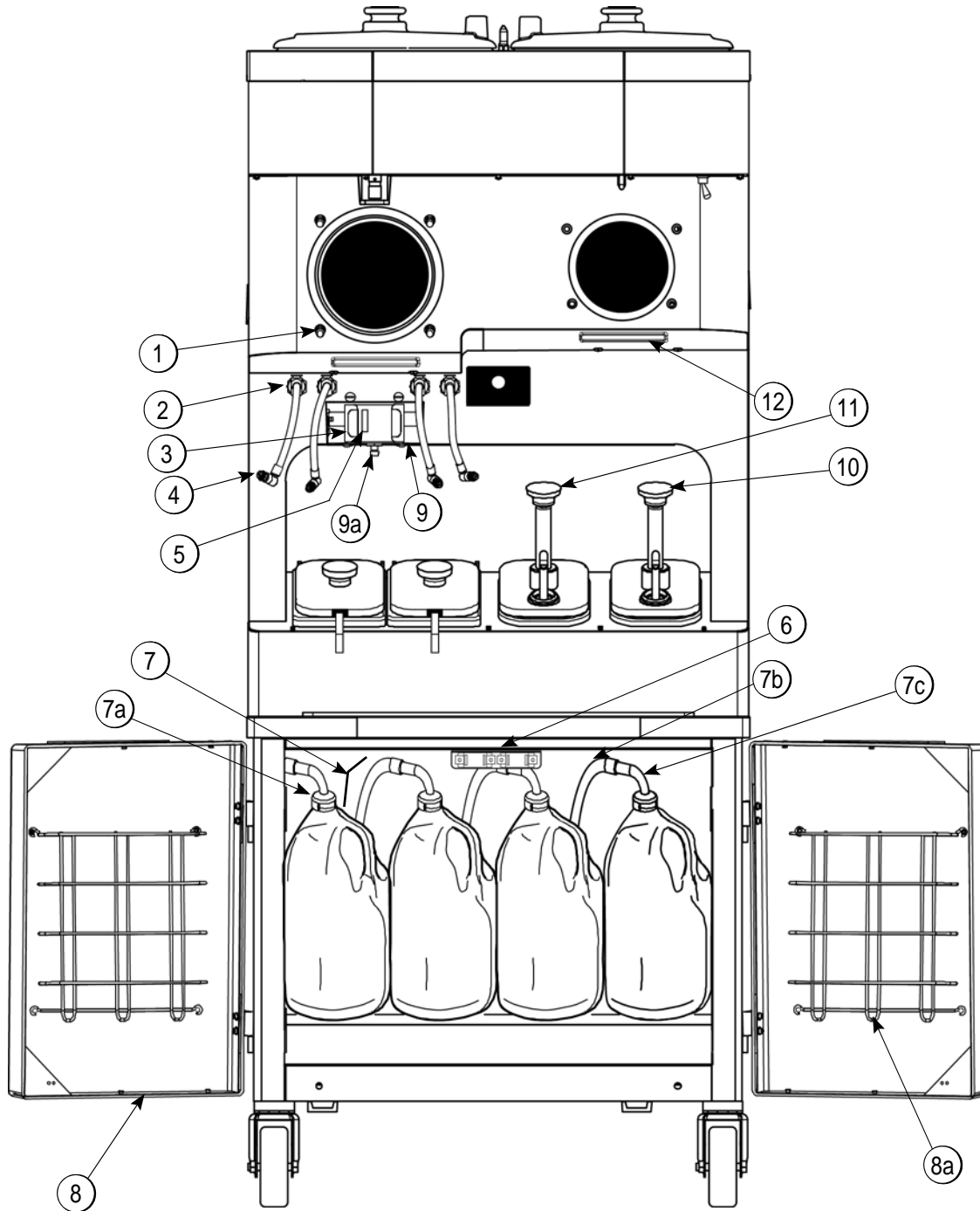

4

Figure 4-2

OPERATOR PARTS IDENTIFICATION

Front View

Item	Description	Part No.
1	Stud-Nose Cone	055987
2	Fitting-Panel Mount QD	056674
3	Clip-Spring-Cup Holder	068394
4	Line A.-Syrup Door	X59304
5	Sensor A.-Pyroelectric	X59268-SER
6	Kit A.-Syrup Door (magnetic catch)	X65932 Consists of:
	Screw-6-32X3/8 SLTD	(4) 002201
	Magnet-Catch Assy.	(2) 016121
	Nut-10-32 Flange Locknut	(4) 020983
	Screw-10-32X3/8 SLTD	(4) 024298
	Handle-Door Short	(2) 065933
	Bracket-Magnet Door	(1) 065934
7	Fitting A.-Syrup Jug 36"	X53353-BLU
	Fitting A.-Syrup Jug 36"	X53353-BRN
	Fitting A.-Syrup Jug 36"	X53353-RED
	Fitting A.-Syrup Jug 36"	X53353-WHT
7a	Cap-Ultimate Syrup	053040-BLU
	Cap-Ultimate Syrup	053040-RED
	Cap-Ultimate Syrup	053040-BRN
	Cap-Ultimate Syrup	053040-WHT

Item	Description	Part No.
7b	Hose-Beverage 3/8"ID X 5/8	053052-36
7c	Tube A.-Syrup Pick Up	X53175
*7d	Ferrule-.625 ID NP Brass	053036
*7e	Fitting-Peristaltic Pump	054526
*7f	O-ring-.500 OD X .070W (50 to bag)	024278
*	Line A.-Syrup (for use with bag syrup system)	X58450
8	Door A.-Cabinet	X58607-SER
8a	Basket-Door-Wire	059144
*9	Holder A.-25DCC PYR SNS	X69102
*9a	Screw-Adjustment-5/16-18	051574
10	Pump A.-Syrup-Heated- BRN	X53800-BRN
11	Pump A.-Syrup-Heated- Tan	X53800-TAN
12	Gasket-Drip Lip	036435

*Not Shown

4

Syrup Cabinet View

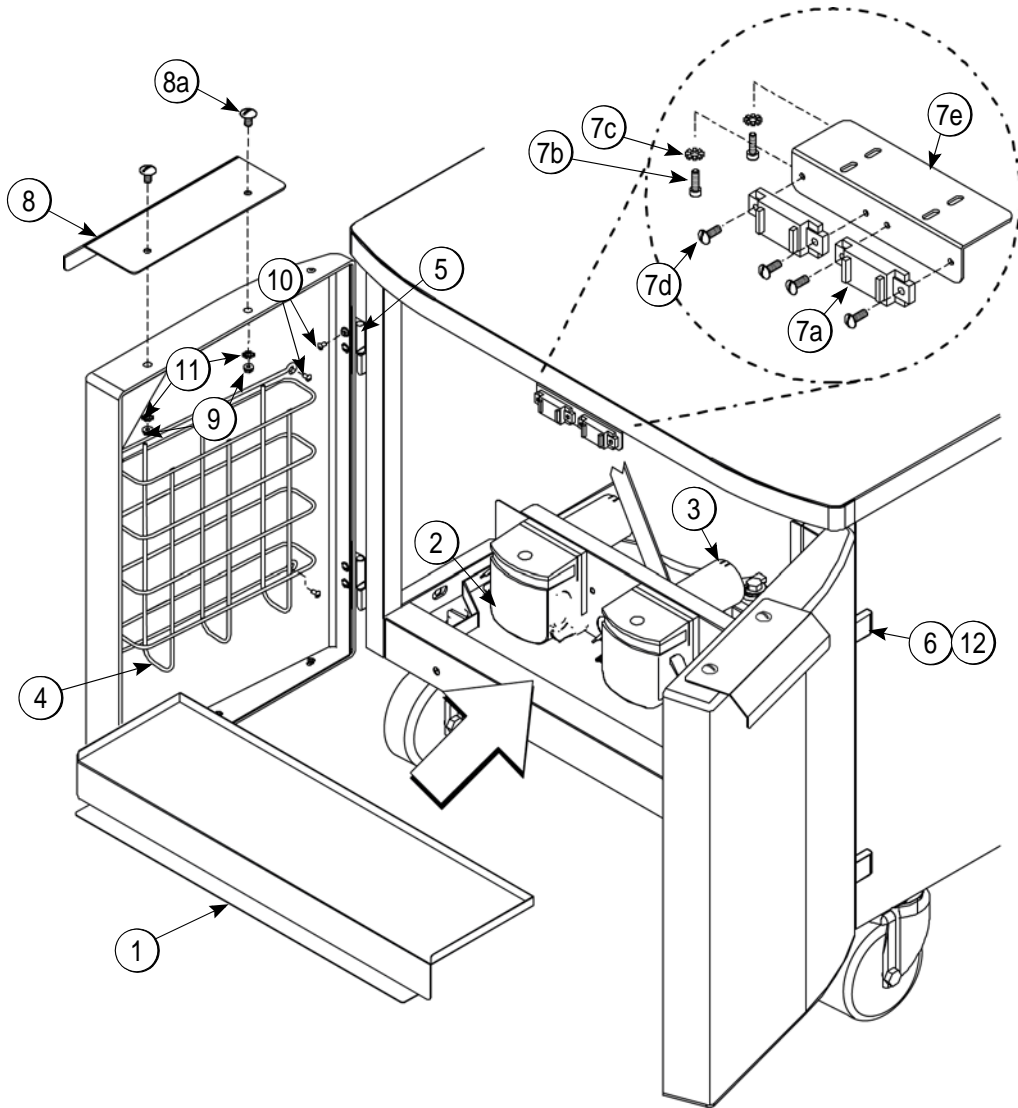

4

Figure 4-3

Item	Description	Part No.
1	Shelf-Syrup	056016
2	Pump-Peristaltic	052916
3	Motor-Gear 161 RPM/ Short Shaft	058725-SER
4	Basket-Door-Wire	059144
5	Block-Hinge	058613
6	Block-Hinge	058614
*7a	Magnet-Catch Assy.	016121
7b	Screw-4-40x3/8 Socket Cap	058317

Item	Description	Part No.
7c	Washer-#4 Ext Tooth Lock	043075
7d	Screw-6-32X3/8 SLTD BIND	002201
7e	Bracket-Magnet Door	065934
8	Handle-Door Short	065933
8a	Screw-10-32X3/8 SLTD TRUS	024298
9	Nut-10-32 Flange Locknut	020983
10	Screw-10-32X3/8 SLTD	006749
11	Washer-#8 Ext Tooth Lock	000964
12	Screw-8-32X1/4 SLTD Round	016540

*Prior to S/N K4091994, use 058630 Latch-Door-Magnetic.

Syrup Pump and Tubes

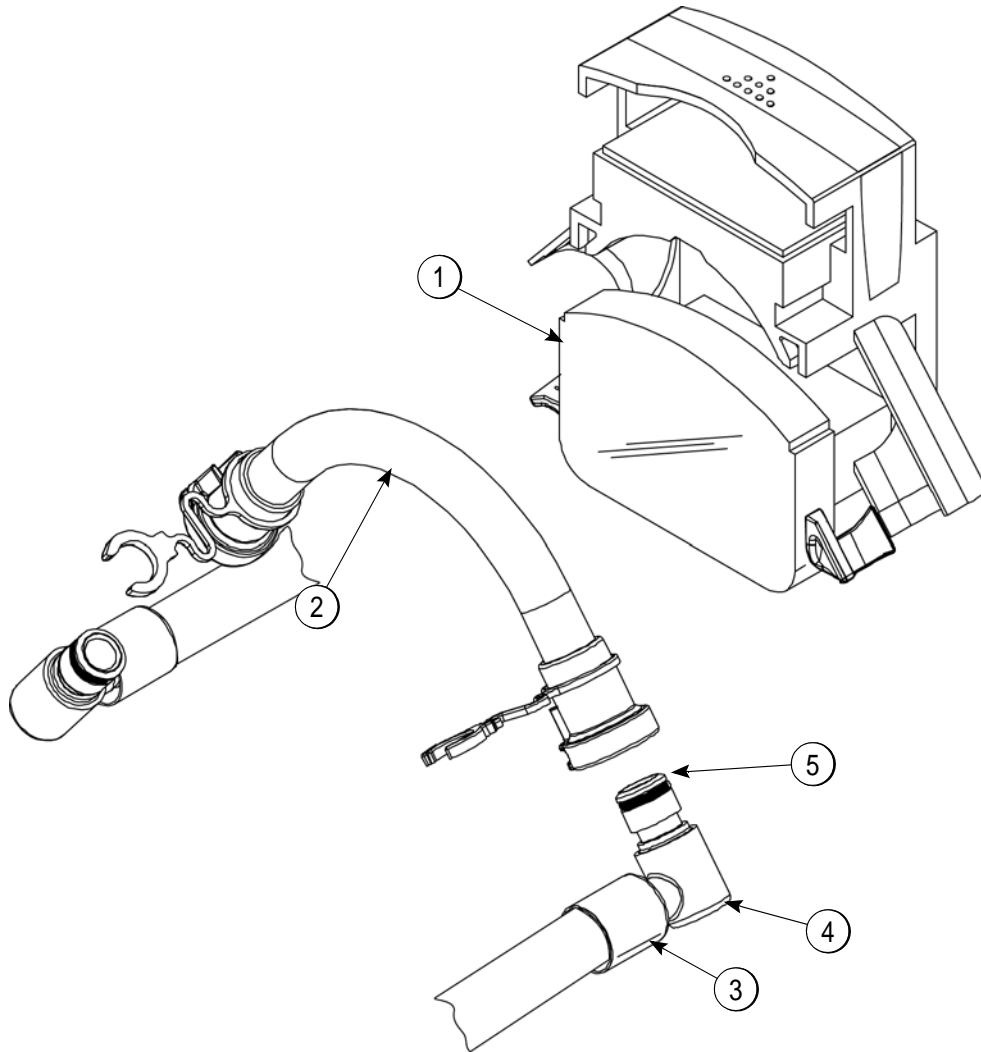

Figure 4-4

Item	Description	Part No.
1	Pump-Peristaltic	052916
2	Kit A.-Peristaltic Pump Tube (1 Tube Kit)	X54978
	Kit A.-Peristaltic Pump Tube (4 Tube Kit)	X54979

Item	Description	Part No.
3	Ferrule- .625 ID	053036
4	Fitting-Peristaltic Pump	054526
5	O-ring 1/2 OD x .070	024278
*6	Line A.-Syrup	X62426-8

*Not Shown

X57028-XX Pump A.—Mix Simplified - Shake

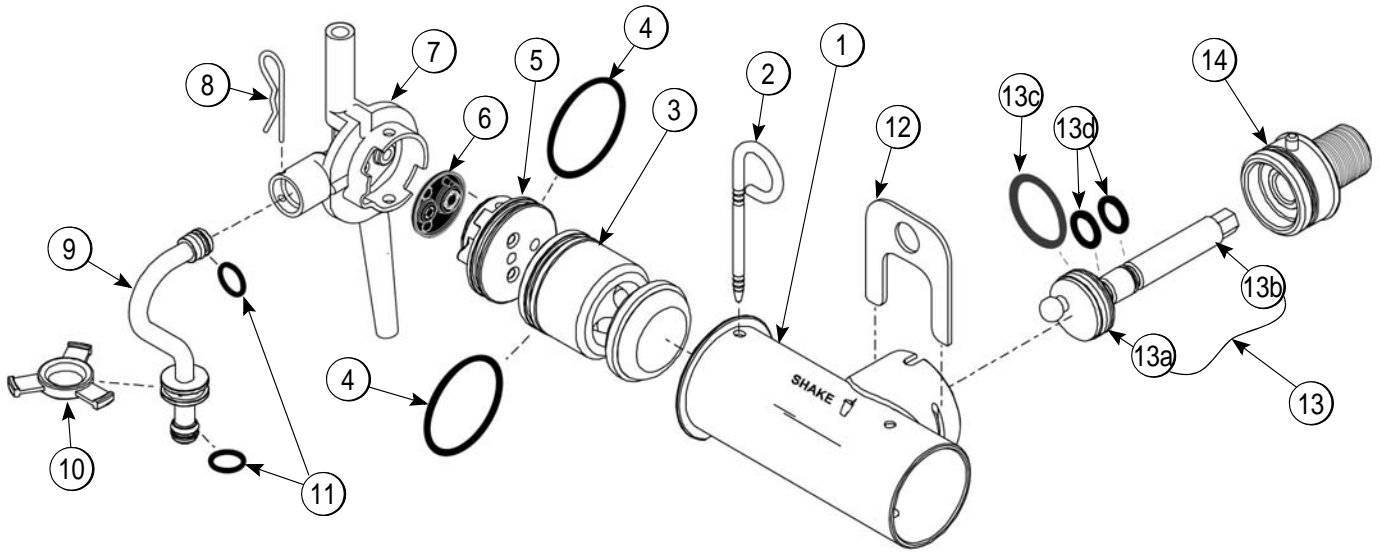

Figure 4-5

Item	Description	Part No.
1-7	Pump Assembly-Mix Simplified Shake	X57028-10
1	Cylinder-Pump Hopper Shake	057944
2	Pin-Retaining	X55450
3	Piston-Pump-Simplified	053526
4	O-ring-2-1/8 OD X .139W-#225	020051
*5	Cap-Valve Body Shake	056873-10
6	Gasket - Simplified Pump Valve	086097
7	Adaptor - Mix Inlet - Shake Blue	054944
8	Pin-Cotter-Hairpin-1/8DIA	044731
9	Tube A.-Feed Tube-SHK	X55973

Item	Description	Part No.
10	Ring-Check-Feed-Tube	056524
11	O-ring-11/16ODX.103W-Red (50 to bag)	016132
12	Clip-Retainer-Mix Pump	044641
13	Shaft A.-Drive-Mix Pump-Hopper	X41947
13a	Crank-Drive-Hopper Mix Pump	039235
13b	Shaft-Drive-Mix Pump- Hopper	041948
13c	O-ring-1-3/4 OD X .139W (25 to bag)	008904
13d	O-ring 1/2 ID X .139W (25 to bag)	048632
14	Sleeve A.-Mix Pump	X44761

*Standard Cap-Valve Body Shaft is -10. Available in other sizes.
[X55973](#) Sleeve A.-Mix Pump

X57029-XX Pump A.—Mix Simplified - Soft Serve

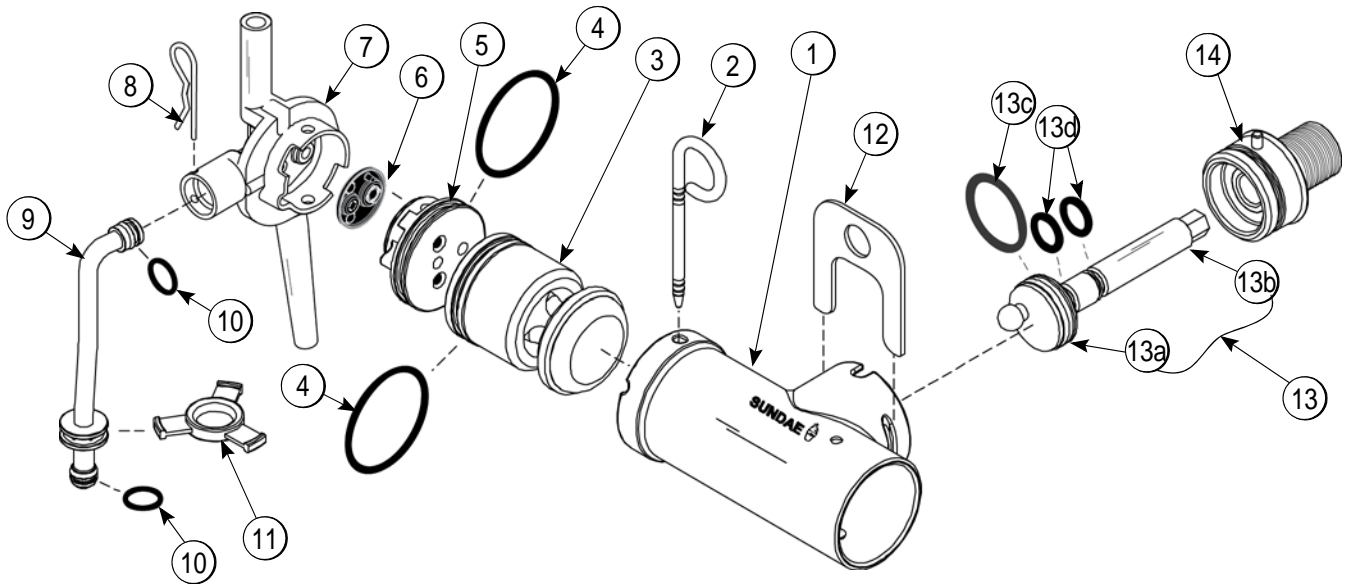

Figure 4-6

Item	Description	Part No.
1-7	Pump A.-Mix Simplified S.S.	X57029-12
1	Cylinder-Pump Hopper Softserve	057943
2	Pin-Retaining	X55450
3	Piston-Pump-Simplified	053526
4	O-ring-2-1/8 OD X .139W-#225	020051
5	Cap-Valve Body SS	056874-12
6	Gasket-Simplified Pump Valve	086097
7	Adaptor-Mix Inlet-SS-Red	054825
8	Pin-Cotter-Hairpin-1/8DIA	044731
9	Tube A.-Feed Tube-SS	X55974
10	O-ring-11/16ODX.103W-Red	016132

Item	Description	Part No.
11	Ring-Check-Feed-Tube	056524
12	Clip-Retainer-Mix Pump	044641
13	Shaft A.-Drive-Mix Pump- Hopper	X41947
13a	Crank-Drive-Hopper Mix Pump	039235
13b	Shaft-Drive-Mix Pump- Hopper	041948
13c	O-ring-1-3/4 OD X .139W	008904
13d	O-ring 1/2 ID X .139W	048632
14	Sleeve A.-Mix Pump *HT	X44761

***Note:** The Standard Pump is [X57029-12](#). Overrun can be changed higher or lower by substituting the valve body cap. The higher the (-), the higher the overrun.

X59304 Syrup Line Assembly—Thin Viscosity Syrup

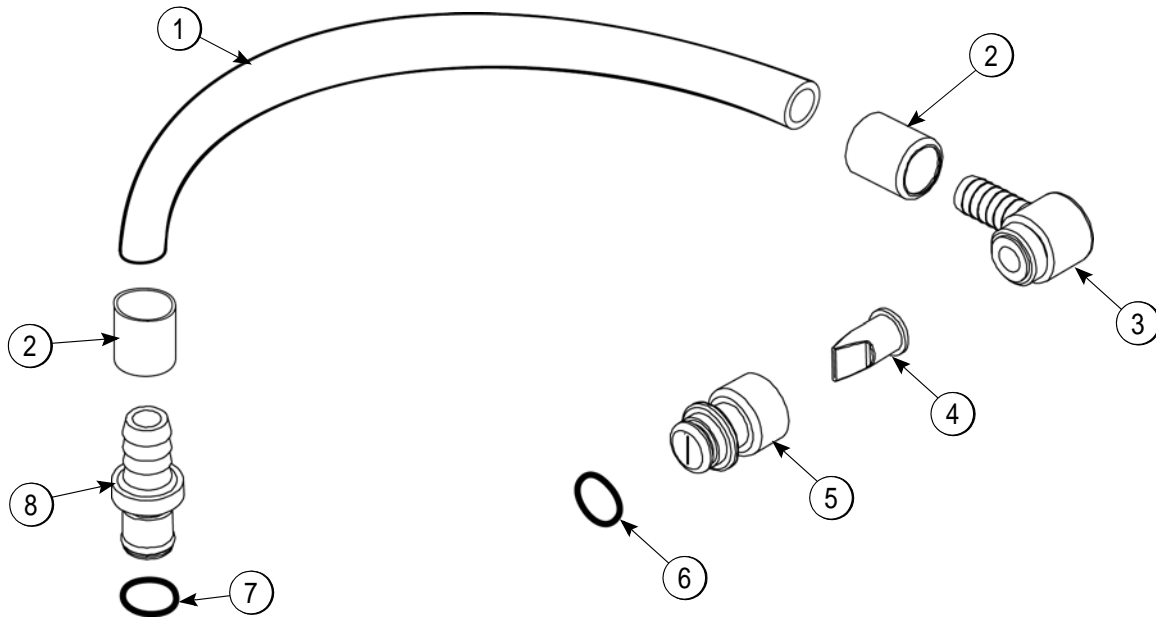

4

Figure 4-7

Item	Description	Part No.
1	Tube-Nylobrade 3/8IDX5/8	500038-9
2	Ferrule-.650 ID NP Brass	029834
3	Fitting-Syrup Elbow	056651
4	Valve-Check-Duckbill	500598
5	Fitting-Syrup Nose .075 Slot	056649

Item	Description	Part No.
6	O-ring-11mm ID X 2mm W Green	053890
7	O-ring-11mm ID X 2mm W Green (25 to bag)	053890
8	Insert-QD-CPC-3/8 Barb	056675

X56652 Syrup Line Assembly—Thick Viscosity Shake Syrup (Optional)

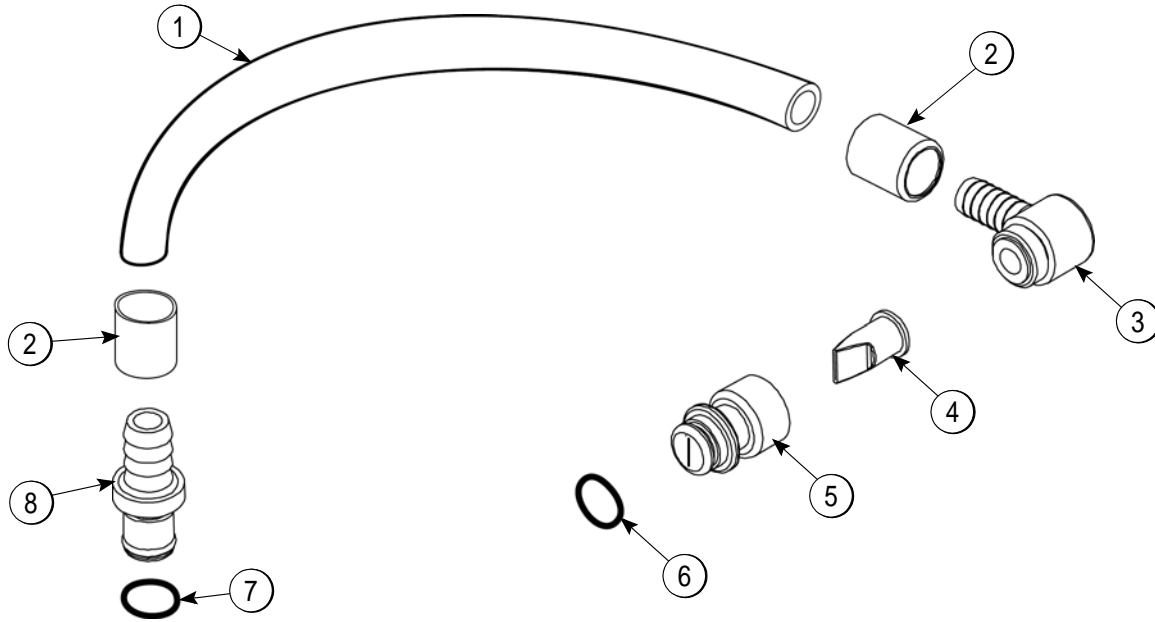

4

Figure 4-8

Item	Description	Part No.
1	Hose-Beverage	053052-9
2	Ferrule-.625 ID	053036
3	Fitting-Syrup Elbow	056651
4	Valve-Check Duckbill	500598
5	Fitting-Syrup Nose (Large Slot)	056650

Item	Description	Part No.
6	O-ring-11 mm Green (Syrup Hole Plug)	053890
7	O-ring	500205
8	Fitting-Barb	056675

X58450 Syrup Line Assembly—Syrup-in-Bag Option

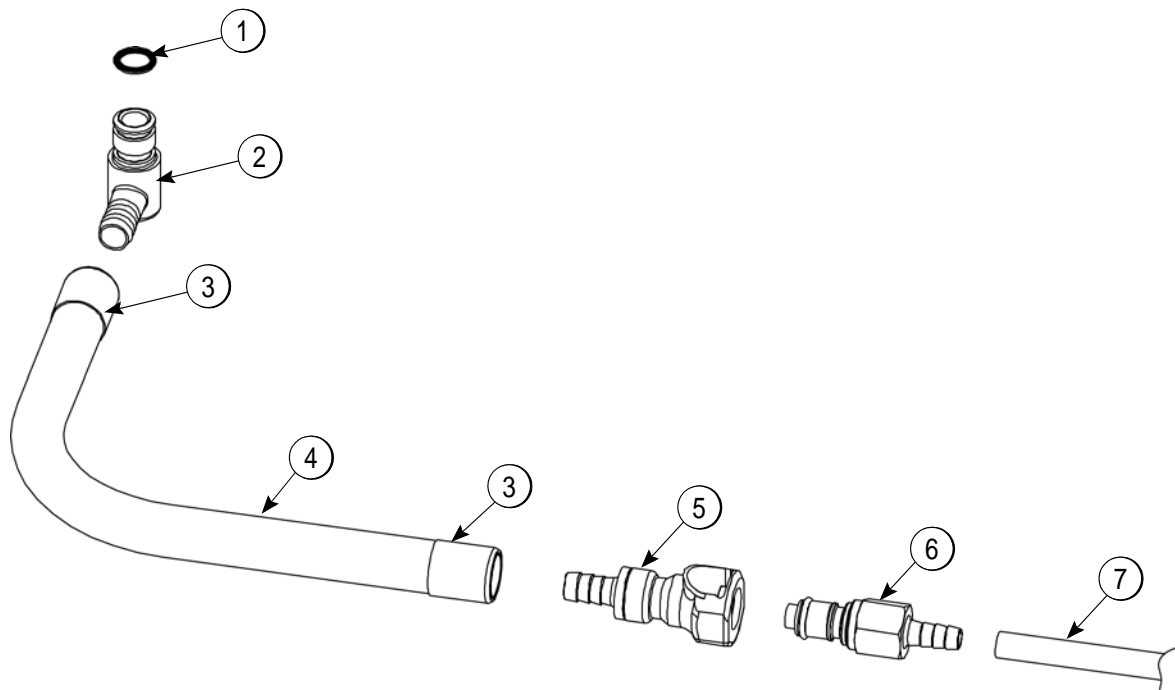

4

Figure 4-9

Item	Description	Part No.
1	O-ring 1/2 OD X .070	024278
2	Fitting-Male	054526
3	Ferrule- .625 ID NP Brass	053036
4	Hose-Beverage 3/8 ID	053052-36

Item	Description	Part No.
5	Coupling-QD Female 3/8	058451
6	Coupling-QD Male 1/4 Barb	058452
7	Tube-Vinyl 3/16 ID X 1/16 W (R30314)	020940-8

Mix Hopper—Top View

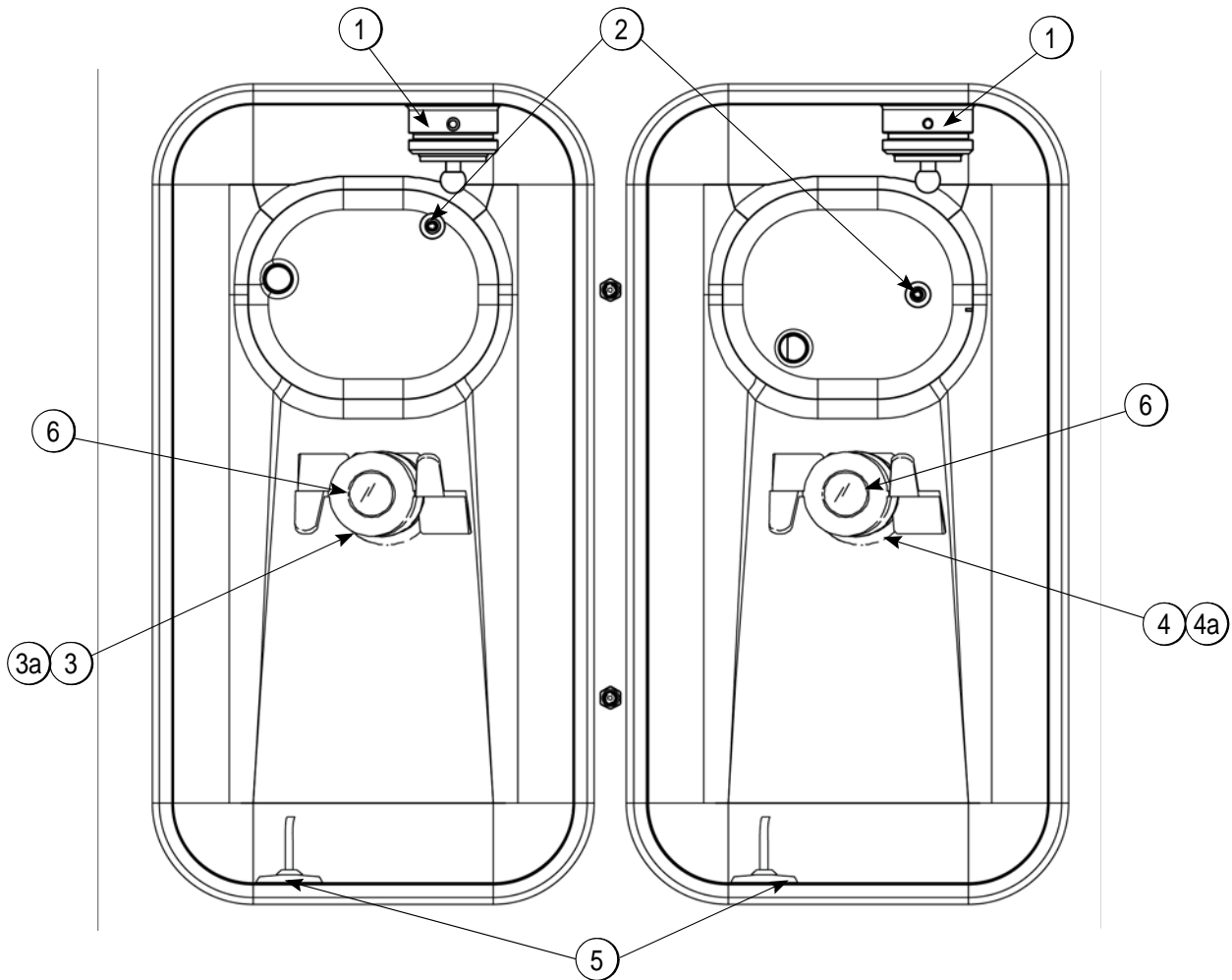
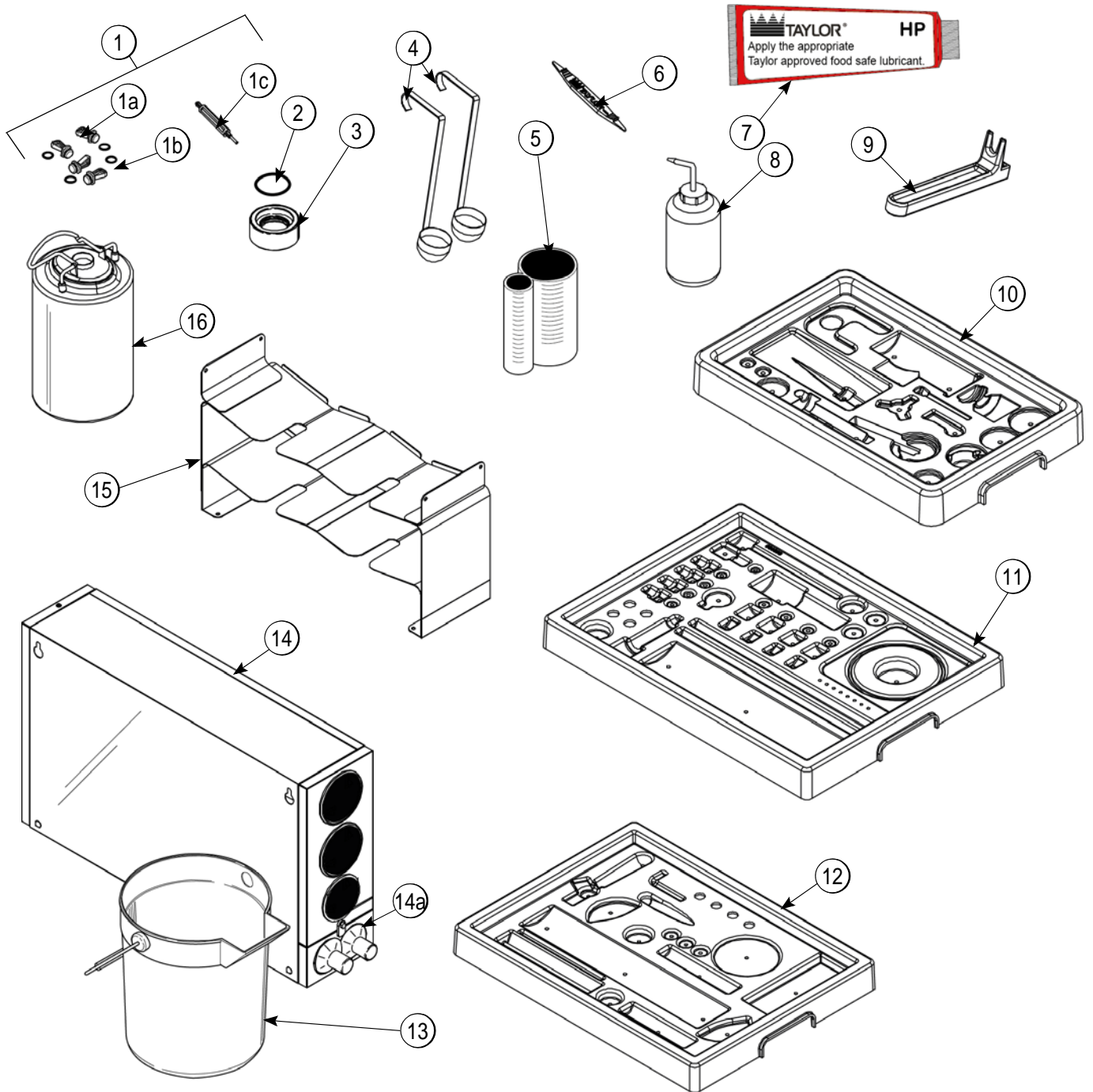

Figure 4-10

Item	Description	Part No.
1	Sleeve A.-Mix Pump	X44761
2	Probe A.Mix Out	X41348
3	Housing A.-Agitator (Shake)	X51664
3a 4a	Magnet A.-Agitator-Inner	X41733

Item	Description	Part No.
4	Housing A.-Agitator (Soft Serve)	X51661
5	Probe A.-Mix Low	X42077
6	Cap-Magnet	080826

Accessories



4

Figure 4-11

OPERATOR PARTS IDENTIFICATION

Accessories

Item	Description	Part No.
1	Kit A.-Syrup Plug Kit TTS	X58474
1a	Plug-Syrup Port TTS	053867
1b	O-ring-11mm ID X 2mm W Green (25 to Bag)	053890
1c	Tool-Seal Install-Remove	035460
2	O-ring-1-11/16 OD X.139W (25 to bag) (Draw Valve Cap)	041923
3	Cap A.-Valve-Draw	X54704
4	Ladle-1 oz-120D Bend	033637-1
5	Cup-Divided Syrup	017203
6	Tool-O-ring Removal	048260-WHT
7	Lubricant-Taylor Hi PERF	048232
8	Bottle-Wash-Plastic	044818
9	Tool-Mix Pump Shaft Removal	057167
10	Tray-Parts-Pump-SIMPL	056525
11	Tray-Parts-Shake Side	059088

Item	Description	Part No.
12	Tray-Parts-SS Side	059087
13	Pail-10 qt.	013163
14	Dispenser A.-Cup-2 Cone	X56121
14a	Baffle-Rubber Cone	052193
15	Tray A.-Syrup (Optional Syrup in Bag System)	X59143
16	Tank-Syrup 4qt. PSD (Optional 4 Tank Syrup System)	056673
*	Kit A.-Peristaltic Pump Tube	X54978
*	Kit A.-Topping Pump Spares	X53795
*	Kit A.-Tune Up Blade	X49463-94
*	Deflector-Blower Exhaust	047912
*	Box-Tool 15 inch Plastic	058669

*Not Shown

X44127 Brush Kit Assembly

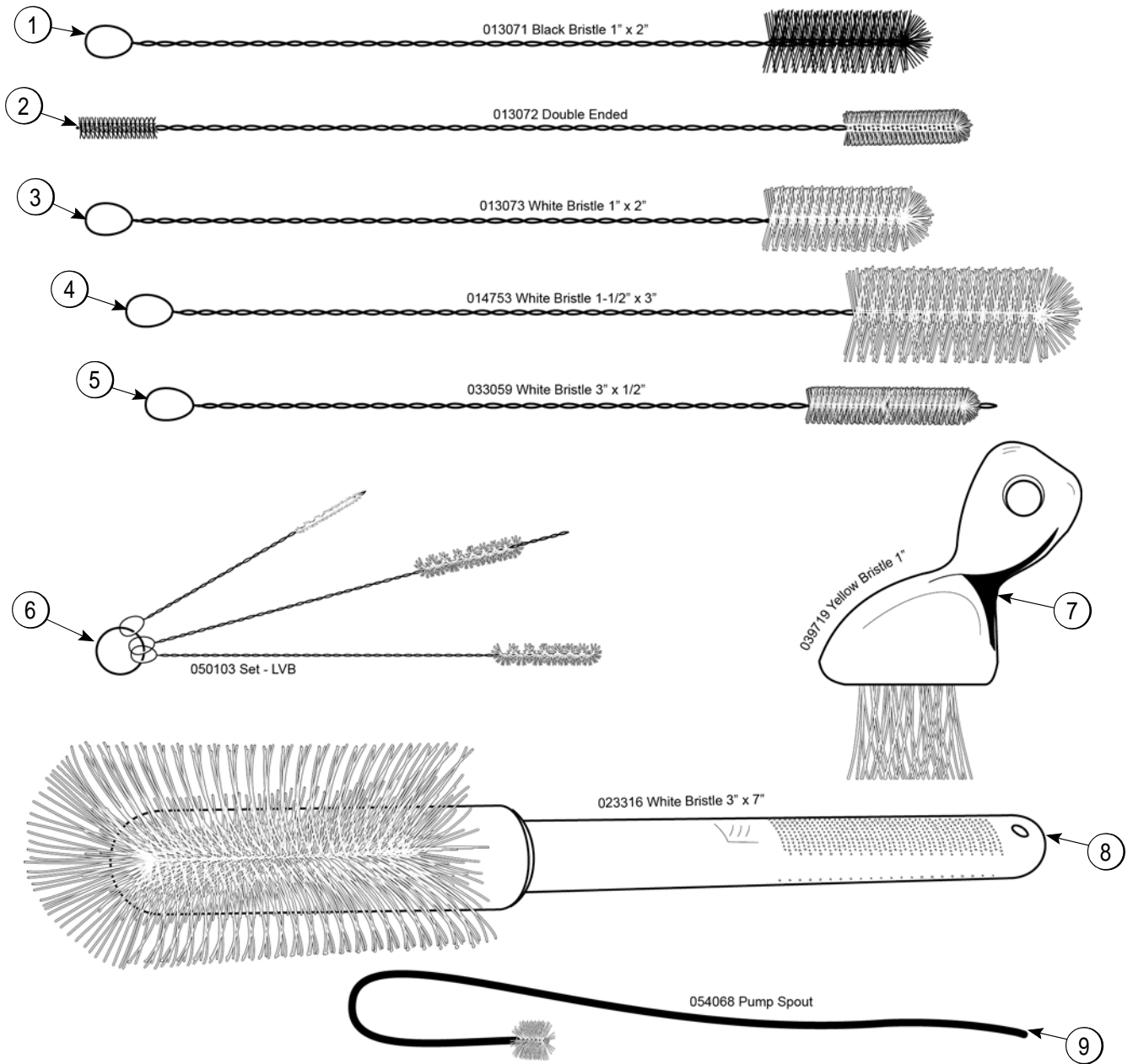

4

Figure 4-12

Item	Description	Part No.
1	Black Bristle Brush	013071
2	Double End Brush	013072
3	White Bristle Brush (1" x 2")	013073
4	White Bristle Brush (1-1/2" x 3")	014753
5	White Bristle Brush (1/2" x 3")	033059

Item	Description	Part No.
6	Brush Set (3)	050103
7	Yellow Bristle Brush	039719
8	White Bristle Brush (3" x 7")	023316
9	Brush-Pump Spout	054068

X53800-BRN/TAN Syrup Pump

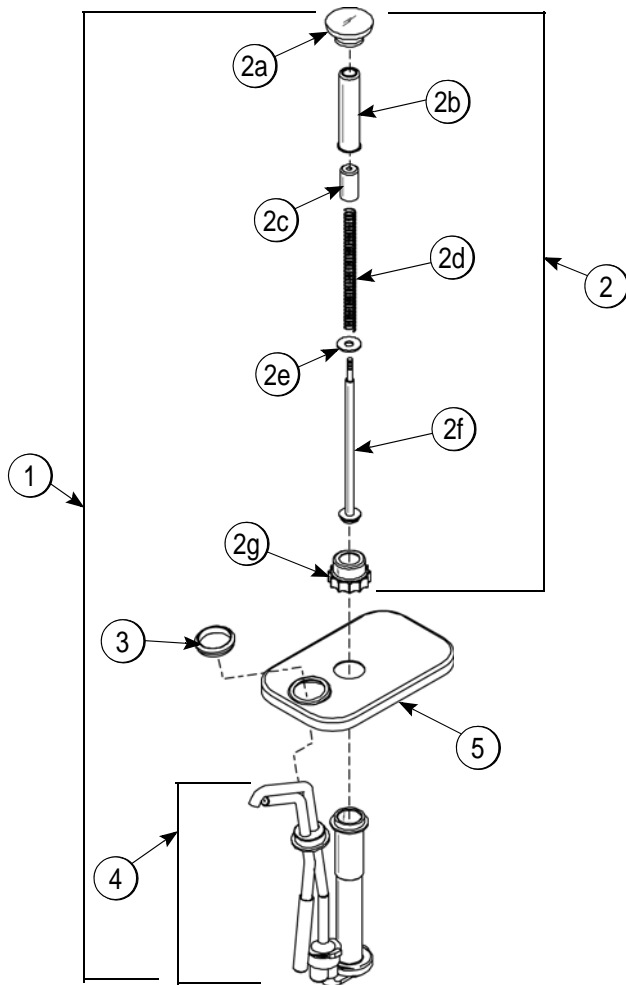

Figure 4-13

Item	Description	Part No.
1	Pump A.-Syrup-Heated	X53800-BRN
	Pump A.-Syrup-Heated	X53800-TAN
2	Plunger A.-Brown	X36576-BRN
	Plunger A.-Tan	X36576-TAN
2a	Knob-Plunger Brown- Syrup Pump	032762-BRN
	Knob-Plunger Tan-Syrup Pump	032762-TAN
2b	Tube-Plunger	032757
2c	Insert-Plunger	032758
2d	Spring-Plunger-Syrup Pump	032761
2e	Washer-Nylon	032760
2f	Plunger	036578
2g	Seal A.	X33057
*2h	Nut-Plunger	036577
3	Nut-Lock-Syrup Pump	039680
4	Pump A.-Syrup Heated Shallow	X53798-SER
5	Lid	036579

Note: Shown for reference only. Not supplied with new machines.

*Not Shown

Beater Door Assembly—Shake Side

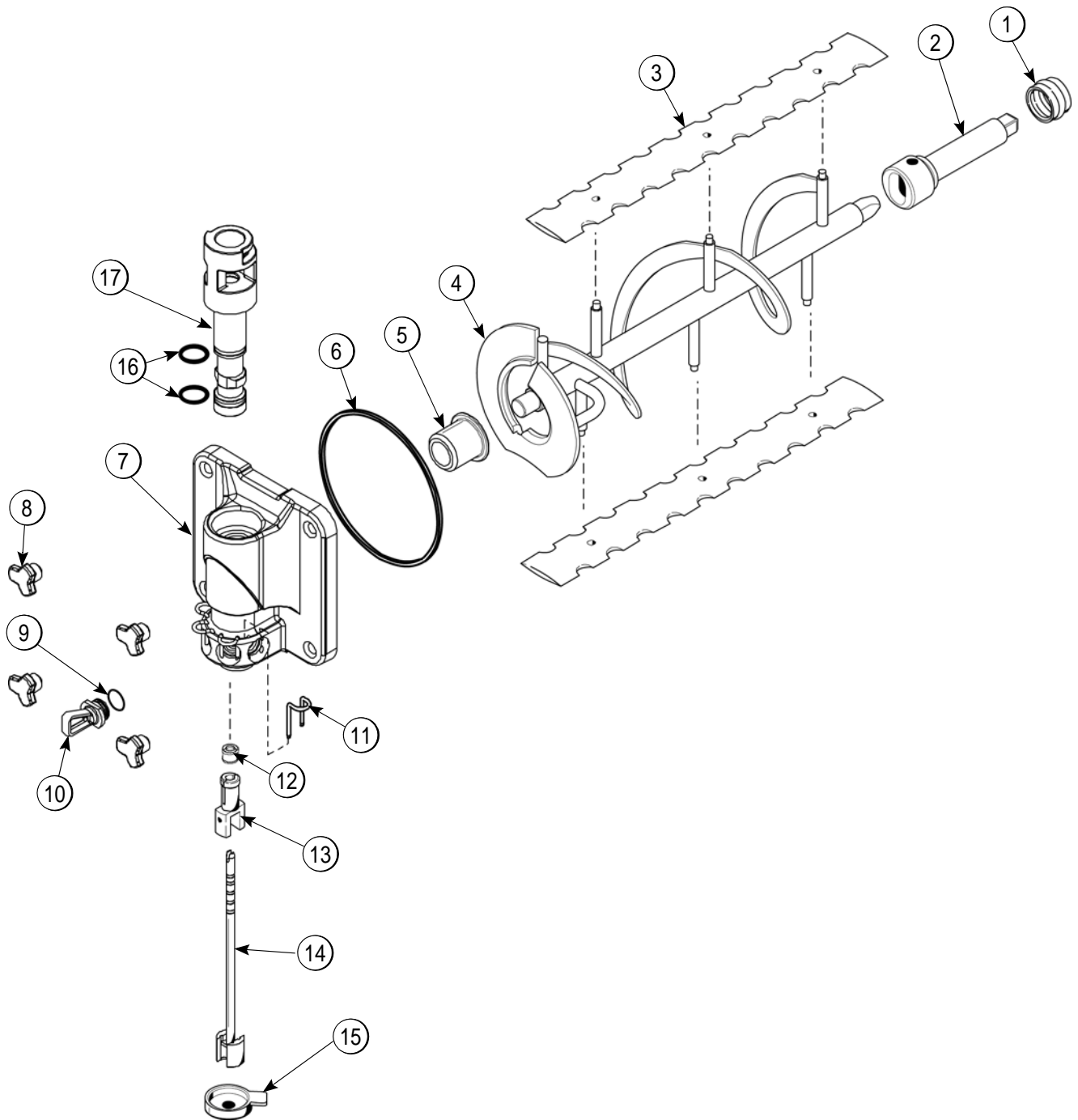

4

Figure 4-14

OPERATOR PARTS IDENTIFICATION

Beater Door Assembly—Shake Side

Item	Description	Part No.
1	Seal-Drive Shaft	032560
2	Shaft-Beater 7 qt.	050985
3	Blade-Scraper 16"	041103
4	Beater A.-7 qt. Fluted Blade	X50958
5	Bearing-Door Front	055605
6	O-ring 6" (Freezer Door)	033493
7	Door A.-Shake Side	X55825SER2
8	Nut-Stud-Short	055989
9	O-ring Syrup Port 11 mm	053890

Item	Description	Part No.
10	Plug-Syrup Port	053867
11	Retainer-Syrup Valve	054554
12	Seal-Spinner Shaft	084696
13	Spinner	034054
14	Blade A.-Spinner	X59331
15	Cap-Restrictor	033107
16	O-ring 1-1/16 OD X .139 W (Draw Valve)	020571
17	Valve A.-Draw	059000

Beater Door Assembly—Soft Serve Side

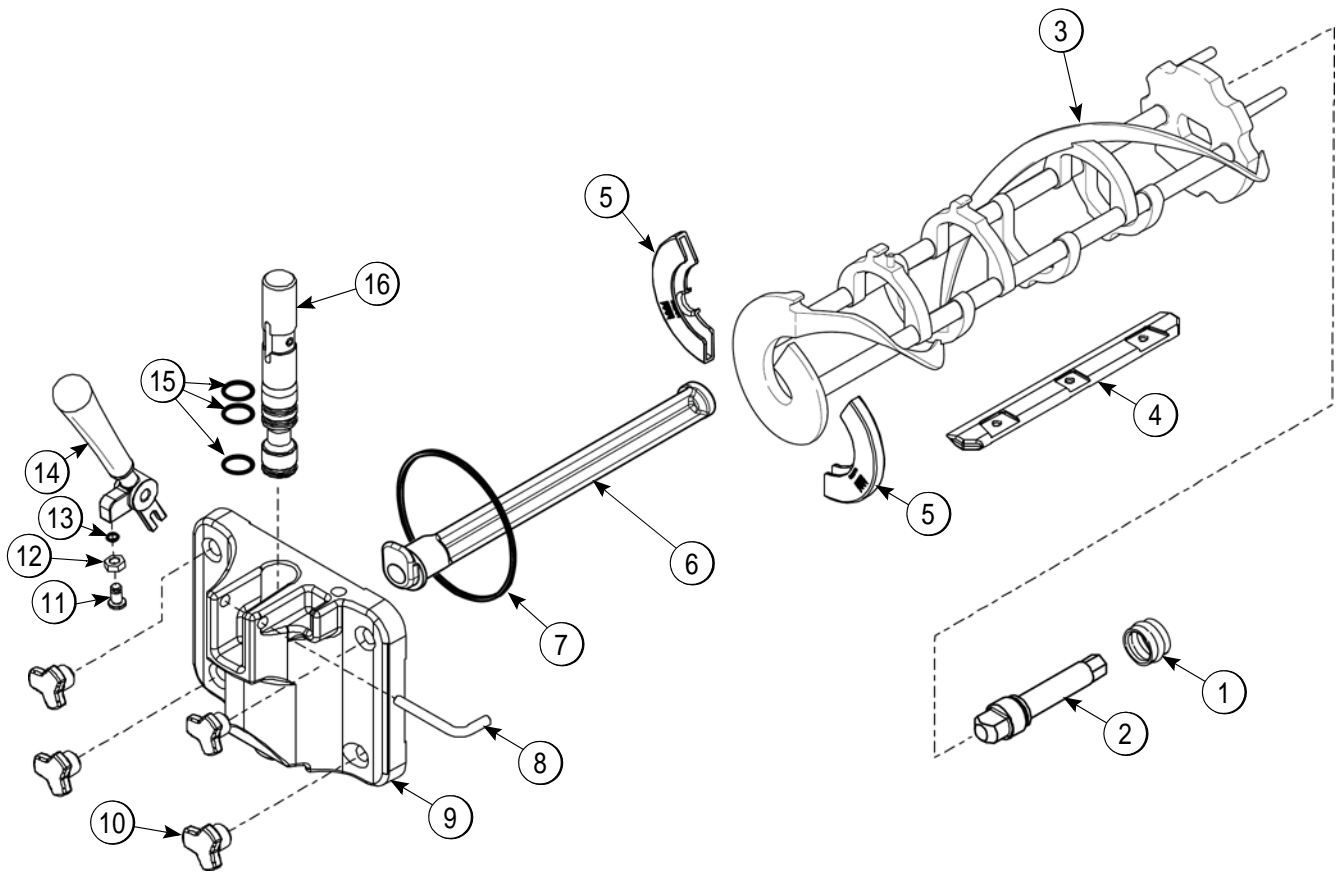

Figure 4-15

Item	Description	Part No.
1	Seal-Drive Shaft	032560
2	Shaft-Beater	032564
3	Beater A.-3.4qt-1 Pin	X46231
4	Blade-Scraper-Plastic 9-13/16L	084950
5	Kit A.-Beater-Front Shoes-Bearing	X50350
6	Baffle -Threadless Molded	087708
7	Gasket-Door HT 4"-Double	048926
8	Pin-Handle-SS	055819
9	Door A.-1SP 3.4QT Threadless	X87683

Item	Description	
10	Nut-Stud-Black-1.00	055989
11	Screw-Adjustment-5/16-24	056332
12	Nut-5/16-24 Finished Hex	029639-BLK
13	O-ring-1/4 OD X .070W 50 DURO (25 to Bag)	015872
14	Handle A.-Draw	X56421-1
15	O-ring-7/8 OD X .103W (100 to Bag)	014402
16	Valve A.-Draw	X55820

059088 Parts Tray—Shake Side

4

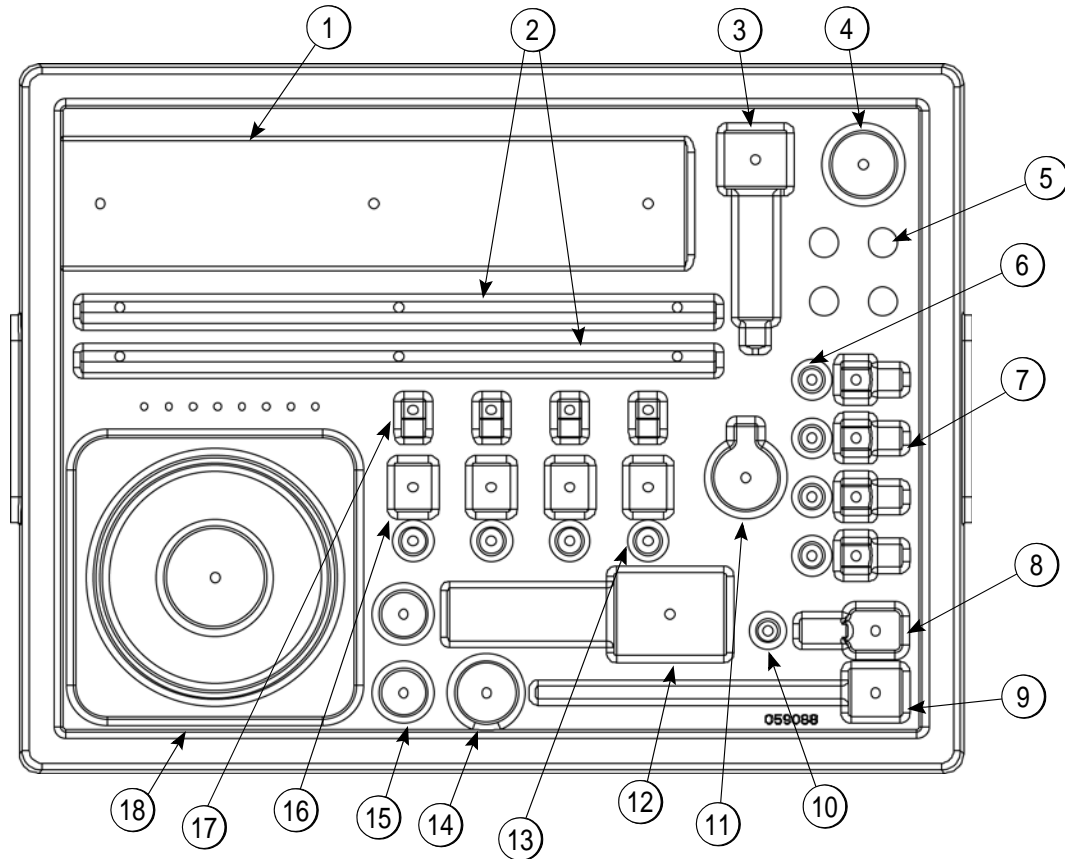
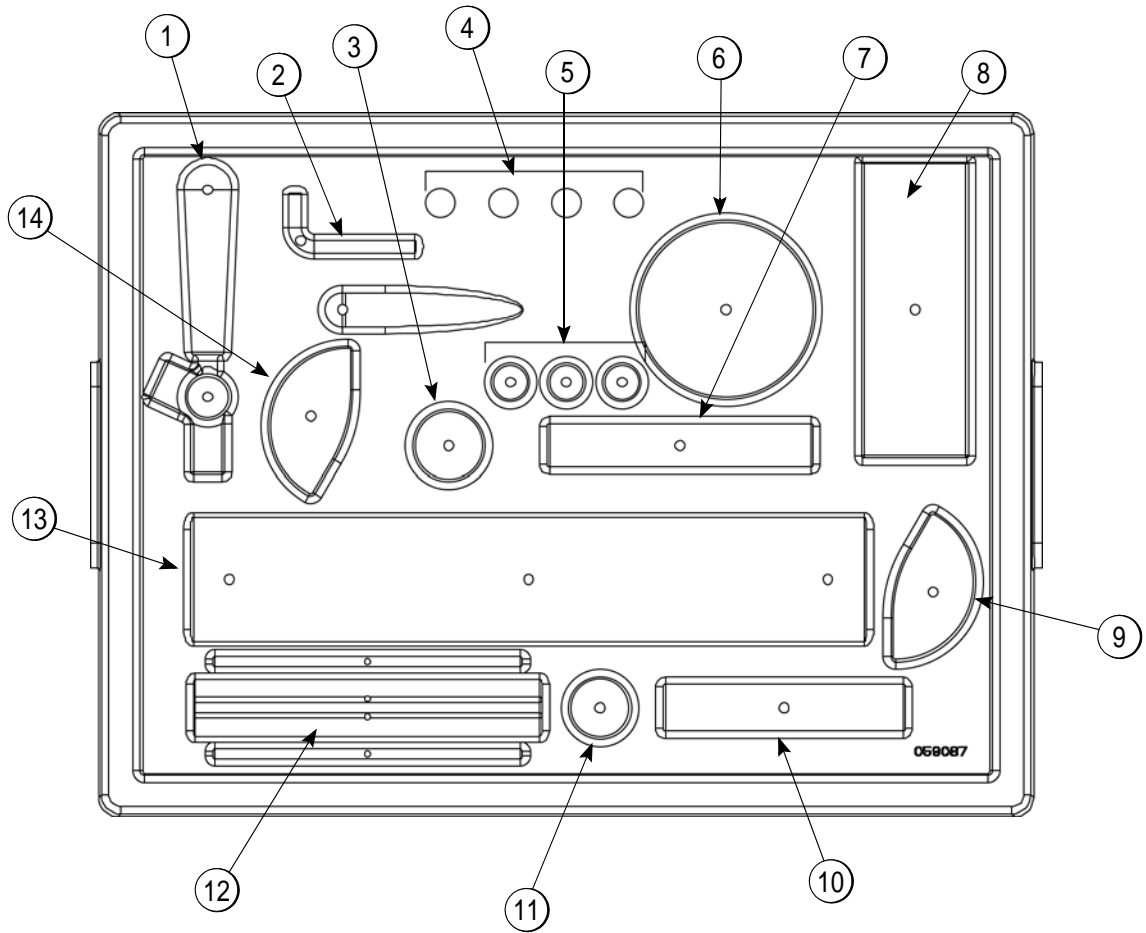

Figure 4-16

Item	Description	Part No.
1	Beater A.-7 qt.	X50958
2	Blade-Scraper-16"	041103
3	Shaft-Beater 7 qt.	050985
4	Seal-Drive Shaft	032560
5	Nut-Stud	055989
6	O-ring-Syrup Port 11mm ID Green	053890
7	Plug-Syrup Port	053867
8	Spinner	034054
9	Blade A.-Spinner	X59331
10	Seal-Spinner Shaft	084696

Item	Description	Part No.
11	Cap-Restrictor	033107
12	Valve A.-Draw	X57169
13	Valve-Check Duckbill	500598
14	Bearing-Door Front	055605
15	O-ring-1-1/16 OD (Draw Valve)	020571
16	Fitting-Syrup Nose	See pages 4-9 and 4-10
17	Retainer-Syrup Valve	054554
18	O-ring 6"-Door	033493
	Door A.-Shake	X55825SER2

059087 Parts Tray—Soft Serve Side



4

Figure 4-17

Item	Description	Part No.
1	Handle A.-Draw	X56421-1
2	Pin-Pivot	055819
3	Bearing-Front	050348
4	Nut-Stud	055989
5	O-ring (Draw Valve)	014402
6	Gasket (Freezer Door)	048926
7	Valve A.-Draw	X55820

Item	Description	Part No.
8	Door A.-w/Baffle	X57332-SER
9	Shoe-Front Helix- Front	084108
10	Drive Shaft	032564
11	Seal-Drve Shaft	032560
12	Blade-Scraper-Plastic 9-13/16L	084950
13	Beater A.	X46231
14	Shoe-Front Helix- Rear	084109

056525 Parts Tray—Simplified Pump

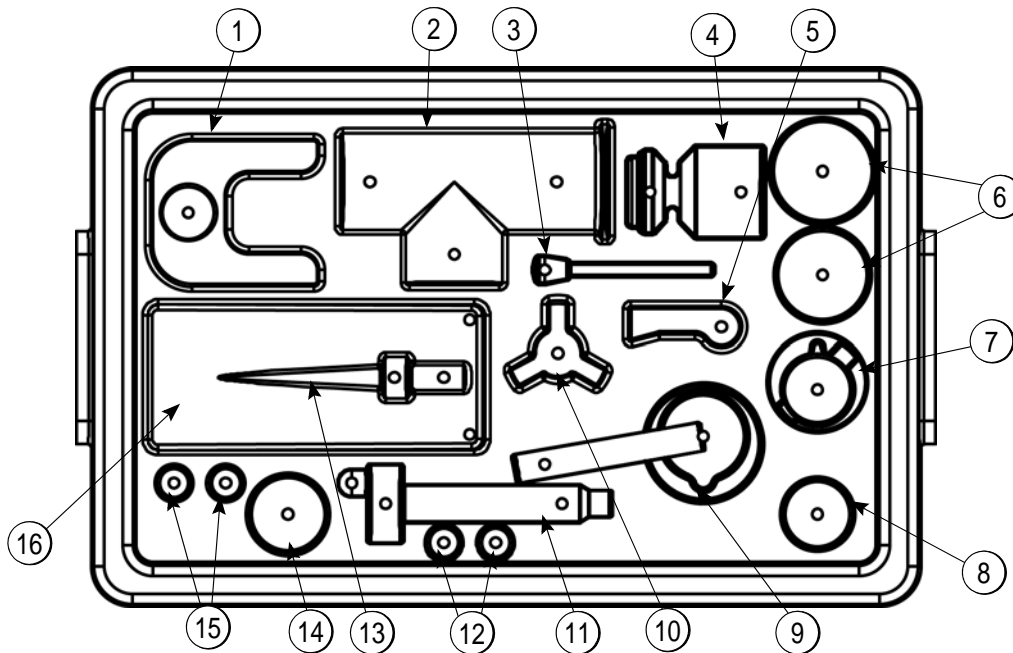

Figure 4-18

4

Shake Side

Item	Description	Part No.
1	Clip-Mix Pump Retainer	044641
2	Cylinder-Pump-Hopper Shake	057944
3	Pin-Retaining	X55450
4	Piston	053526
5	Pin-Cotter	044731
6	O-ring 2-1/8" OD - Red	020051
7	Cap-Valve	056873-XX
8	Gasket-Simplified Pump Valve	086097
9	Adaptor-Mix Inlet Shake-Blue	054944
10	Ring-Check .120 OD	056524
11	Shaft A.-Drive Mix Pump	X41947
12	O-ring-Drive Shaft	048632
13	Tube A.-Feed-Hopper Shake	X55973
14	O-ring 1-3/4	008904
15	O-ring-11/16 OD - Red	016132

Soft Serve Side

Item	Description	Part No.
1	Clip-Mix Pump Retainer	044641
2	Cylinder-Pump-Hopper- Soft Serve	057943
3	Pin-Retaining	X55450
4	Piston	053526
5	Pin-Cotter	044731
6	O-ring 2-1/8" OD - Red	020051
7	Cap-Valve	056874-XX
8	Gasket-Simplified Pump Valve	086097
9	Adaptor-Mix Inlet Soft Serve-Red	054825
10	Ring-Check .120 OD	056524
11	Shaft A.-Drive Mix Pump	X41947
12	O-ring-Drive Shaft	048632
13	Tube A.-Feed-Hopper Soft Serve	X55974
14	O-ring 1-3/4	008904
15	O-ring-11/16 OD - Red	016132
16	Agitator A.-Mix Hopper	X44797

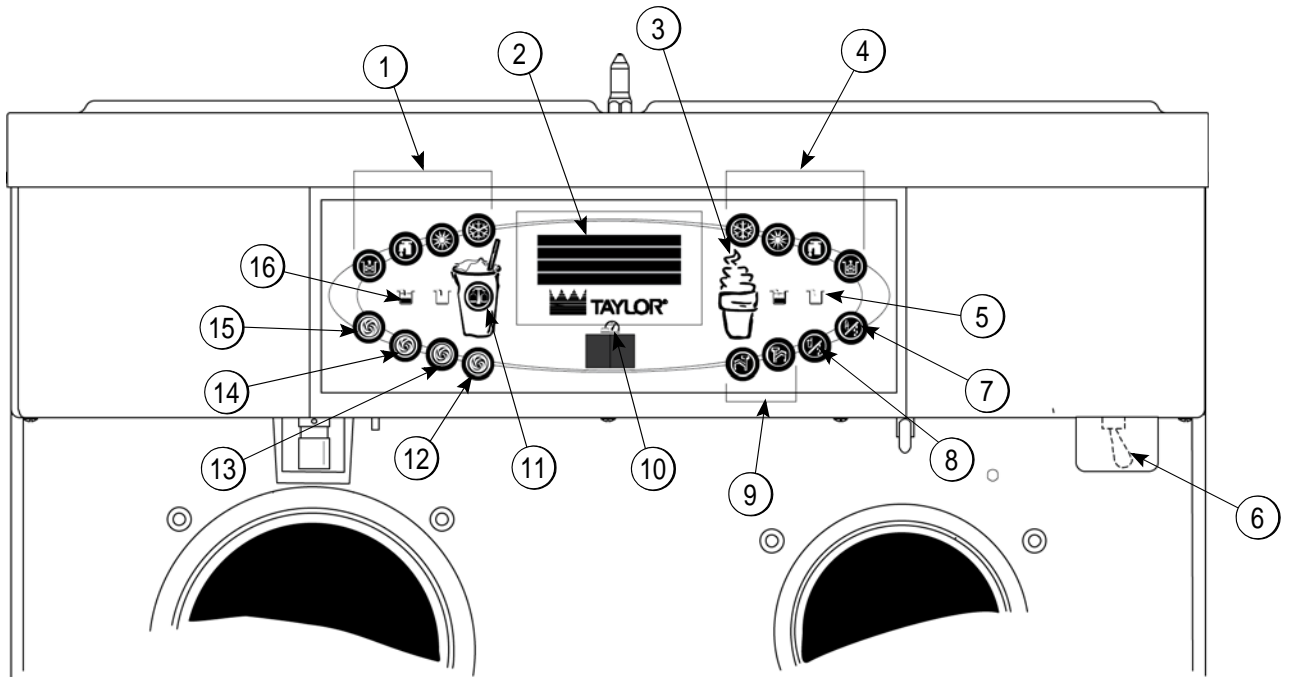

Figure 5-1

Item	Description
1	Key—Shake
2	Display—Vacuum Fluorescent Menu (VFD)
3	Key—Menu (Entry/Exit)
4	Keys—Soft Serve
5	Indicator Light—Mix Out
6	Switch—Power
7	Standby—Soft Serve
8	Standby—Shake

Item	Description
9	Keys—Topping Heaters
10	Display—LED (Brush Clean Countdown)
11	Key—Calibrate Menu
12	Key—Flavor Selection
13	Key—Vanilla Flavor
14	Key—Strawberry Flavor
15	Key—Chocolate Flavor
16	Indicator Light—Mix Low

Note: See “Manager’s Menu” on page 5-7 for additional key functions when the Calibration or Manager’s Menu is displayed.

Symbol Definitions

To better communicate in the international arena, symbols have replaced words on many of our operator keys, switches, functions, and fault indicators. Your Taylor machine is designed with these international symbols.

The following chart identifies the symbol definitions:

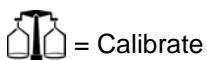
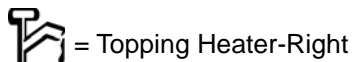
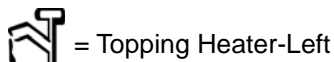
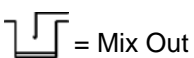
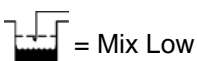
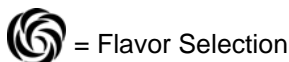
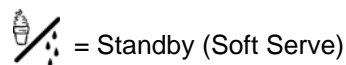
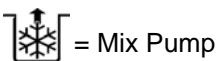
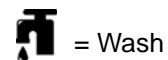
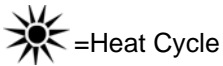
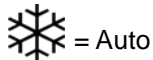

5

Power Switch



When placed in the ON position, the power switch allows control panel operation.

Vacuum Fluorescent Display

The vacuum fluorescent display (VFD) is located on the front control panel. During normal operation the display is blank. The display is used to show menu options and notifies the operator if a fault is detected. The display will indicate the temperature of the mix in each hopper.

Indicator Lights

Mix Low—When the Mix Low  indicator light is illuminated, the mix hopper has a low supply of mix and should be refilled as soon as possible.

Mix Out—When the Mix Out  indicator light is illuminated, the mix hopper has been almost completely exhausted and has an insufficient supply of mix to operate the freezer. At this time, the Auto mode is locked out and the freezer will be placed in the Standby mode. To initiate the refrigeration system, add mix to the mix hopper and press the Auto key . The freezer will automatically begin operation.

Heat Cycle Key

When the Heat Cycle key  is illuminated, the freezer is in the process of a heat cycle. The Heat Cycle key may be selected to start a heat cycle following a freezer soft lock condition.

For some models, the Heat Cycle key can be selected to manually start a heat cycle at any time.

Brush-Clean Countdown—Displays the number of days before the next brush-cleaning is required. When the display has counted down to 1, the machine must be disassembled and brush-cleaned within 24 hours.

Reset Mechanism

The Reset button is located in the service panel at the rear of the machine. (See Figure 5-2.) It protects the beater motor from overloading. Should an overload occur, the reset mechanism will trip. To properly reset the freezer, place the power switch in the OFF position. Press the Reset button firmly. Turn the power switch to the ON position. Press the Wash key  and observe the freezer's performance.

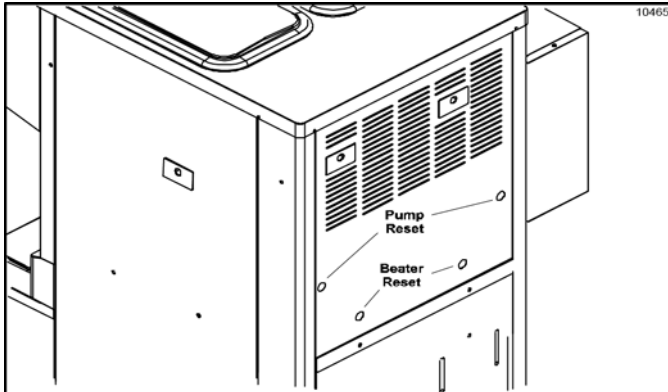



Figure 5-2



CAUTION! DO NOT use metal objects to press the reset button. Failure to follow this instruction may result in electrocution.

If the beater motor is turning properly, press the Wash key  to cancel the cycle. Press the Auto key  to resume normal operation. If the freezer shuts down again, contact your authorized service technician.

Air/Mix Pump Reset Mechanism

The Reset button for the pump is located in the service panel at the rear of the machine. (See Figure 5-2.) The reset protects the pump from an overload condition. Should an overload occur, the reset mechanism will trip. To reset the pump, press the Reset button firmly.

Adjustable Draw Handle

This machine features an adjustable draw handle to provide the best portion control, giving a better, consistent quality to your product and controlling costs. The draw handle should be adjusted to provide a flow rate of 5 oz. to 7-1/2 oz. (142 g to 213 g) of product by weight per 10 seconds. To increase the flow rate, tighten the screw. To decrease the flow rate, loosen the screw. After setting the flow rate, tighten the jam nut to secure the adjustment screw. (See Figure 5-3.)

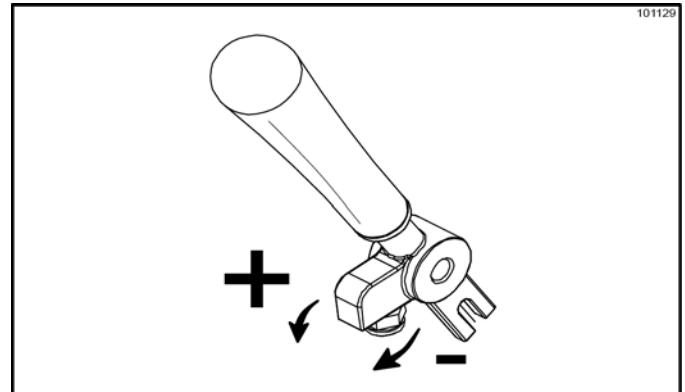

Figure 5-3

Shake Fill Level Adjustment

The portion control sensor located under the cup holder can be adjusted to fill the cup to the desired level. If the fill level is too low, or the cup is overflowing, it may be necessary to adjust the sensor position. (See Figure 5-4.)

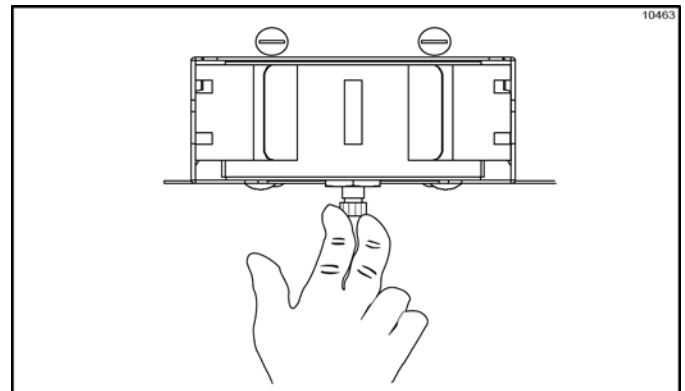



Figure 5-4

1. Using a crescent wrench, loosen the locking nut on the screw adjuster below the sensor.
2. Turn the adjustment screw clockwise to raise the fill level, or counterclockwise to lower the fill level.
3. Once the desired fill level is achieved, tighten the locking nut.

VFD Screens

The vacuum fluorescent display (VFD) located in the center of the control panel is normally blank during the daily operation of the machine. The display is activated

when the Calibrate key  or the Manager's Menu is selected. The display screen will also alert the operator of specific faults detected by the control.

Power Up

When the machine is powered, the control system will initialize to perform a system check. There are four types of data that the system will check when the control is initializing: Lamp Test, Lockout Data, Configuration Data, and System Data.

```
C602 / C606 UVC4
V01.01.000
lamp
test
```

Lamp Test: The control and software version is displayed and all of the LEDs on the display panel are illuminated.

```
Initializing . . . . .
```

Following the lamp test, three separate screens will appear during initialization.

- Initializing Lockout Data
- Initializing Config Data
- Initializing System Data

If the system detects corrupt data during the initializing, the following display will alert the operator that the control settings have changed:

```
SERVICE REQ'D
NVRAM FAULT
RESET TO DEFAULTS
< Press to clear
```

Once the system has initialized, the number of days remaining before the next required brush-cleaning is indicated on the control panel, and the SAFETY TIMEOUT screen is displayed with the alarm turned on.

```
SAFETY TIMEOUT
ANY KEY ABORTS
```

The SAFETY TIMEOUT screen will be displayed with the alarm on, for 60 seconds or until any control key is selected.

After the safety timeout has been completed and the power switch is OFF, the status screen will display. When the brush-clean requirements have been met, the following screen will display:

```
POWER SWITCH OFF
- - - - -
UNIT CLEANED
```

If a brush-cleaning was not completed, the status screen will display the current hopper temperature, barrel temperature, and 5-minute brush-clean timer.

```
POWER SWITCH OFF
TIME: 5:00
41.0 HOPPER 41.0
41.0 BARREL 41.0
```

Power Switch ON

When the power switch is placed in the ON position, the control panel keys become operative. The VFD will either be blank or indicate that the machine has been cleaned.

```
UNIT CLEANED
```

Some models will continuously display the temperature of each mix hopper when the power switch is in the ON position.

```
HOPPERS          21.0      21.1
UNIT CLEANED
```

5

Heat Treatment Cycle

The Heat Cycle keys  on the control panel illuminate throughout the heat treatment cycle. Two warning messages will be displayed on the screen. DO NOT DRAW will be displayed when the mix temperature is below 130°F (54.4°C).



When the temperature of the mix is above 130°F (54.4°C), the screen will display a message indicating that hot product is in the machine.



Important! Do not attempt to draw product or disassemble the machine during the heat treatment cycle. The product is hot and under extreme pressure.



In the heat treatment cycle, the mix temperature in the hoppers and freezing cylinders must be raised to 151°F (66.1°C) within 90 minutes.

When the heating phase is complete, the freezer goes into the holding phase of the cycle. The holding phase will keep the temperature above 151°F (66.1°C) for a minimum of 30 minutes.

The final phase of the heat treatment cycle is the cooling phase. The freezer must cool the mix below 41°F (5°C) within 2 hours.

When the entire heat cycle has been completed, the Heat

Cycle keys  will no longer be illuminated. The machine will enter the Standby mode (Standby keys

 and  will illuminate). The machine can be placed in Auto or left in Standby.

Heat Treatment Cycle Failure Messages

To comply with health codes, heat treatment system freezers must complete a heat treatment cycle daily, and must be disassembled and brush-cleaned a minimum of every 14 days. Brush-cleaning is the normal disassembly and cleaning procedure found in this manual. Failure to follow these guidelines will cause the control to lock the freezer out of the Auto mode.

Always comply with local guidelines for the maximum number of days allowed between brush-clean cycles. (See “BRUSH CLEAN CYCLE” on page 5-12.)

If the heat treatment cycle fails, the VFD will display a failure message and return the freezer to the Standby mode. A lock is defined as a special Standby mode of operation which does not allow the machine to operate in the Auto mode.

There are two types of freezer lock conditions that can occur: hard lock and soft lock. A hard lock requires the machine to be disassembled and brush-cleaned. A soft lock can be corrected by either disassembling and brush-cleaning the machine, or by starting another heat treatment cycle.

Hard Lock: There are two causes of a hard lock failure.

- The brush-clean timer has elapsed (maximum setting of 14 days).

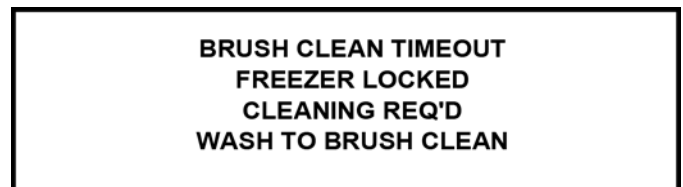

Selecting the Wash key  will display the following screen.

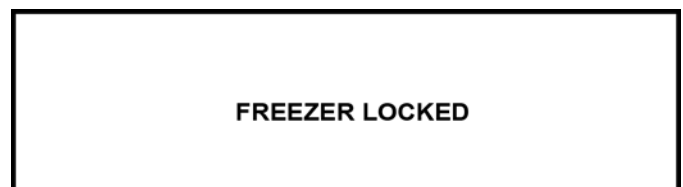

- There has been a thermistor failure (freezing cylinder, hopper, or glycol) during the heat treatment process.

**SYSTEM FAULT
FREEZER LOCKED
SERVICE REQ'D
< PRESS TO CLEAR**

Selecting the Calibrate key  will indicate which thermistor caused the hard lock.

**L: HOPPER THERM BAD
FREEZER LOCKED**

If the machine has hard locked and an attempt is made to enter Auto mode, the machine will enter the Standby mode and display the following message:

FREEZER LOCKED



5 To restore the message that identified the reason for the hard lock, turn the power switch to OFF for 5 seconds and then return the power switch to the ON position. The original message with the reason for the hard lock will be displayed. The fault description can also be found in the Manager's Menu.

The FREEZER LOCKED message will remain on the display until the brush-clean requirements are fulfilled. The freezer must be disassembled in order to activate the 5-minute timer on the display screen. Once the timer counts down to zero, the lockout is cleared.

Soft Lock: If a heat treatment cycle has not been initiated within the last 24 hours, a soft lock failure will occur. A soft lock allows the operator to correct the cause of the soft lock. The operator has the option of either starting another heat cycle or brush-cleaning the machine.

When a soft lock occurs, the machine will go into the Standby mode. The following message is displayed on the screen. The reason for the soft lock is indicated on the second line.

**HEAT TREAT FAILURE
REASON
HEAT FOR HEAT CYCLE
WASH TO BRUSH CLEAN**

If the reason for the soft lock has been corrected, selecting the Heat Cycle key  initiates a heat treatment cycle immediately. Selecting the Wash key  when the above message is displayed will hard lock the machine, and brush-cleaning will be necessary.

The following are the variable messages for soft lock failures that appear on the second line of the screen:

Table 5-1

POWER SWITCH OFF	The power switch was in the OFF position.
MIX OUT PRESENT	There was a mix out condition present.
AUTO OR STANDBY OFF	The machine was not in the Auto or Standby mode.
NO HEAT CYCLE TRIED	A heat treatment cycle was not attempted in the last 24 hours. (AUTO HEAT TIME was advanced, a power loss was experienced at the time the cycle was to occur, or a heat cycle failure not due to a thermistor failure.)



If the following screen appears, a soft lock has occurred during the heat treatment cycle:

**HEAT TREAT FAILURE
FREEZER LOCKED
HEAT FOR HEAT CYCLE
WASH TO BRUSH CLEAN**

A soft lock can also occur anytime during operation when the hopper or freezing cylinder temperature rises above 59°F (15°C), rises and remains above 45°F (7°C) for more than 1 hour, or rises and remains above 41°F (5°C) for more than 4 hours. If a product over temperature condition occurs during operation, the following screen will appear:

**PRODUCT OVER TEMP
HEAT FOR HEAT CYCLE
WASH TO BRUSH CLEAN**

When one of these messages appears, automatic freezer operation cannot take place until the freezer is disassembled and brush-cleaned or has completed a

heat treatment cycle. Select the Heat Cycle key  to start a heat cycle, or select the Wash key  to disassemble and brush-clean the machine.

Once the freezer is unlocked by starting a heat treatment cycle, the Heat Cycle key  will illuminate and the following message will be displayed on the screen:

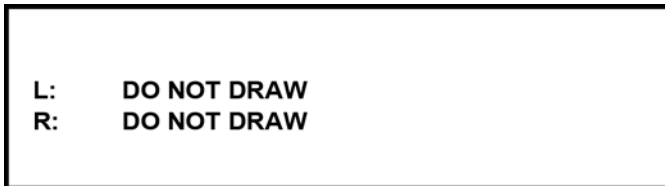

If the Wash  key is selected to clear the lockout by brush-cleaning the machine, the FREEZER LOCKED message will remain on the display until the brush-clean requirements are fulfilled. The freezer must be disassembled in order to activate the 5-minute timer on the display screen. Once the timer counts down to zero, the lockout is cleared.



To restore the message that identified the reason for the soft lock, turn the power switch to OFF for 5 seconds, and then return the power switch to the ON position. The original message with the reason for the soft lock will be displayed.

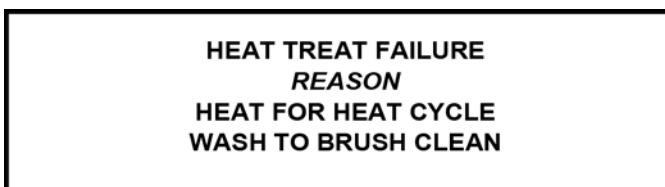

The FAULT DESCRIPTION can also be found in the Manager's Menu. (See "Manager's Menu" on page 5-7.)

Note: A record of heat cycle data and lockout history can be found in the Manager's Menu. (See "Manager's Menu" on page 5-7.)

Manager's Menu

The Manager's Menu is used to enter the operator function displays. To access the Manager's Menu, press the center of the CONE symbol  on the control panel. (See Figure 5-5.)

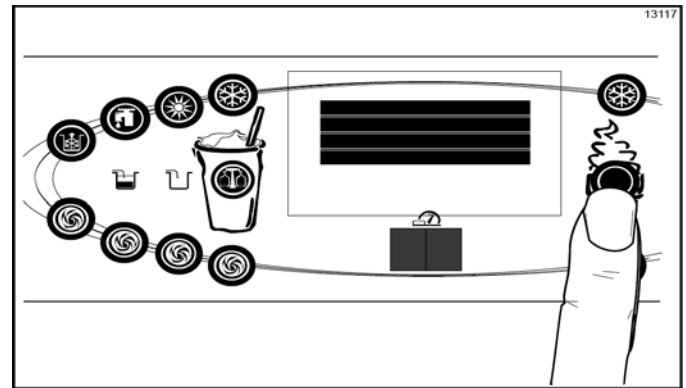











Figure 5-5

The left (shake-side) Auto key , the Flavor Selection key , and the Cone key  will be illuminated when the ACCESS CODE screen is displayed.

In the Menu program, the left (shake-side) Auto key , Flavor Selection key , and Calibration key  will function as menu keys.

Auto —Increases the value above the cursor and is used to scroll upward in text displays.

Flavor Selection —Decreases the value above the cursor and is used to scroll downward in text displays.

Calibration —Advances the cursor position to the right and is used to select menu options.

Note: You will not be able to dispense shakes while accessing the Manager's Menu options, except when the CURRENT CONDITIONS screen is displayed.

The soft serve side will continue operation in the mode it was in when the Manager's Menu was selected. However, the soft serve side control keys will not be illuminated and are nonfunctional when the Manager's Menu or Calibration Menu is displayed.

The control keys for both sides are functional in the Manager's Menu when the CURRENT CONDITIONS screen is displayed. (See "CURRENT CONDITIONS" on page 5-19.)

Entering Access Code

With the ACCESS CODE screen on the display, use the Auto ❄️ or Flavor Selection 🌀 keys to set the first code number in the cursor position. When the correct number is selected, press the Calibration key 🧪 to move the cursor to the next number position.

The access code for the Manager Menu is 8309.

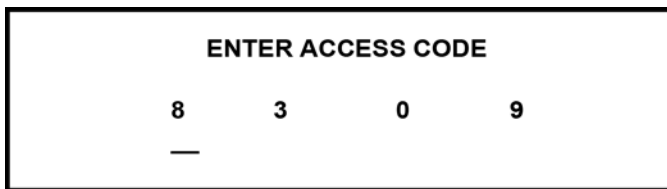

Continue to enter the proper access code numbers until all four numbers are displayed, then press the Calibration

5 key 🧪. The Manager's Menu list will display on the screen, provided the correct access code is entered.

If an incorrect number is entered for the access code, the display will exit the Menu program when the Calibration

key 🧪 is selected. (See Figure 5-6.)

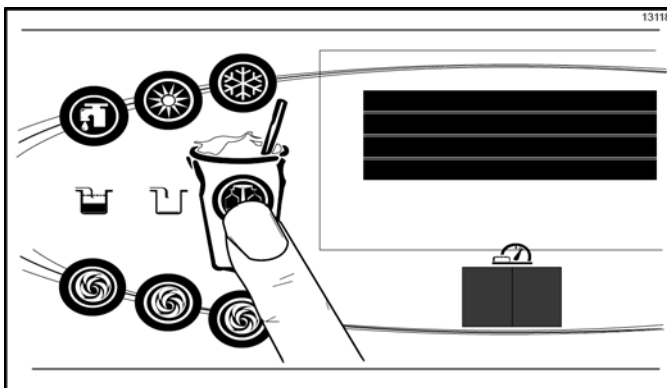

Figure 5-6

Menu Options

Press the Auto key ❄️ or Flavor Selection key 🌀 to move up or down through the Menu. Select a Menu option by aligning the option with the cursor on the left side of the screen, then press the Calibration

key 🧪. Exit the Menu program by selecting EXIT

FROM MENU or pressing the Cone key 🍦.

The following menu options are listed in the Manager's Menu:

- EXIT FROM MENU
- SYRUP CALIBRATION
- VERIFY CALIBRATION
- SERVINGS COUNTER
- SET CLOCK
- AUTO HEAT TIME
- AUTO START TIME
- STANDBY MODE
- BRUSH CLEAN CYCLE
- MIX LEVEL AUDIBLE
- FAULT DESCRIPTION
- LOCKOUT HISTORY
- FAULT HISTORY
- HEAT CYCLE SUMMARY
- HEAT CYCLE DATA
- SYSTEM INFORMATION
- CURRENT CONDITIONS

EXIT FROM MENU

Selecting EXIT FROM MENU exits the Manager's Menu and returns the control panel keys to normal operation.

SYRUP CALIBRATION

Use the SYRUP CALIBRATION option to access the calibration screen selections from the Manager's Menu. The same functions found in the calibration menu are displayed on the screen when this menu option is selected. (See "Syrup System" on page 6-25.)

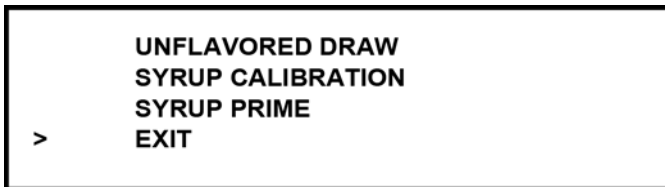

Note: The UNFLAVORED DRAW option will only appear on the screen when the shake side is in the Auto mode.

VERIFY CALIBRATION

Use the VERIFY CALIBRATION to verify the amount of syrup dispensed is within the proper specification.

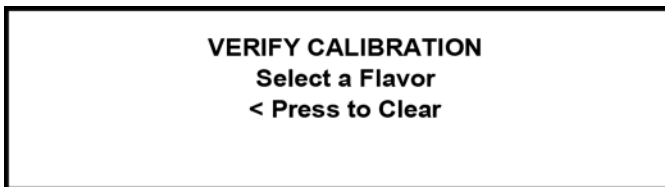

Remove the syrup valve from the dispensing door. With the line fully primed with syrup, position the syrup valve over the small chamber side of the divided syrup cup, then select the corresponding flavor selection. Syrup will flow into the cup and automatically stop. Place the cup on a flat surface and check the amount of syrup dispensed. If the level is not within the correct specification, the flavor will need to be recalibrated. (See "Syrup System" on page 6-25.)

It is recommended to verify the calibration of each syrup flavor and note any flavors that need to be recalibrated before exiting the Manager's Menu to access the CALIBRATION Menu.

Select the Calibration key  to exit the VERIFY CALIBRATION screen and return to the Manager's Menu list.

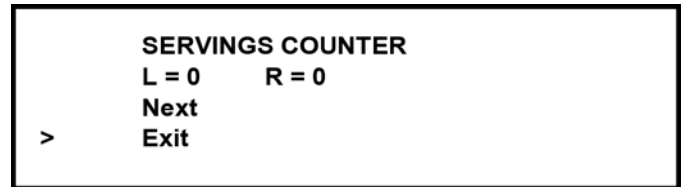

SERVINGS COUNTER

Use the SERVINGS COUNTER screen to check or reset the number of servings dispensed from the machine.



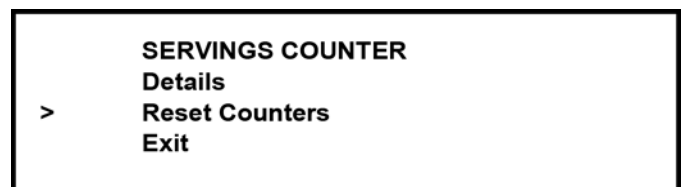

Reset the SERVINGS COUNTER by selecting the Auto key  to move the cursor (>) to Next. The Reset Counters and Details selections will be displayed on the next screen.

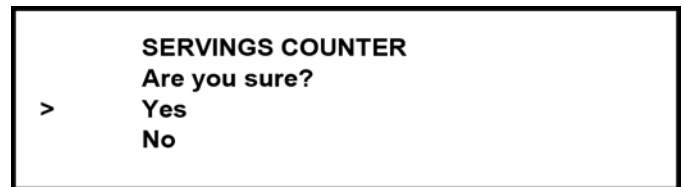

Select the Auto key  to move the cursor to Reset Counters. Then select the Calibration key .



The display will ask, "Are you sure?" To reset the counters, select the Auto key  to move the cursor to Yes. Select the Calibration key  to clear the left and right counters and return to the SERVINGS COUNTER screen. If you do not want to clear the serving counter, move the cursor to No and select the Calibration key  to return to the SERVINGS COUNTER screen without resetting the counters to zero.

Note: The SERVINGS COUNTER will automatically reset to zero when the machine is brush-cleaned.

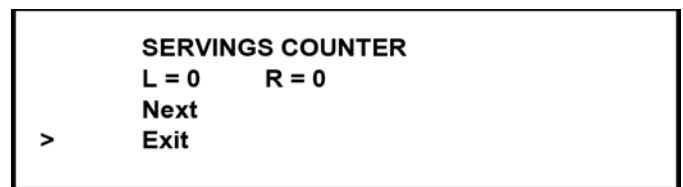

USER INTERFACE

Access the Details screen by selecting Next in the SERVINGS COUNTER screen. Move the cursor to Details and then select the Calibration key .

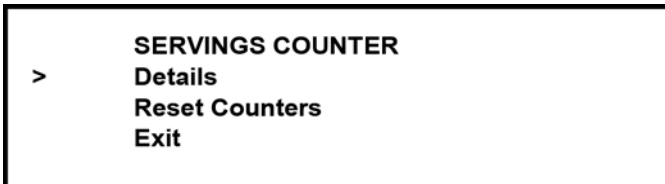

The counter menu will also display details for the number of servings for each flavor (chocolate, strawberry, vanilla, option, unflavored, and soft serve), and count the method that ended the draw for each flavor (pyroelectric sensor detection, manually selecting a flavor key, draw safety timeout, and other).

Example:

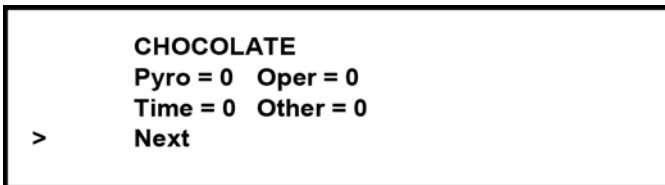

5 **Pyro** = Pyrosensor detected and triggered the end of the draw.

Time = The Draw Safety Time setting was reached before the pyrosensor detection or before a flavor key was selected.



Oper = A flavor key was selected to terminate the draw.

Other = Any draw termination that is not Pyro, Time, or Oper (example: power switch turned off while product is dispensing)

SET CLOCK

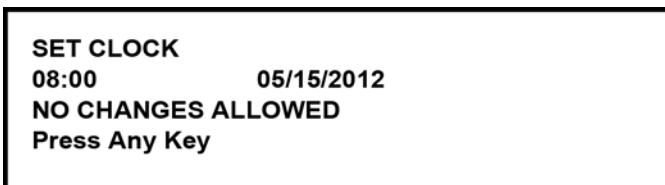

Use the SET CLOCK option to adjust the control clock date and time. The date and time may only be changed after the freezer has been manually cleaned but before it has been placed in the Auto or Standby mode. The following message will be displayed if the SET CLOCK option is selected when the machine is not in a brush-clean state:



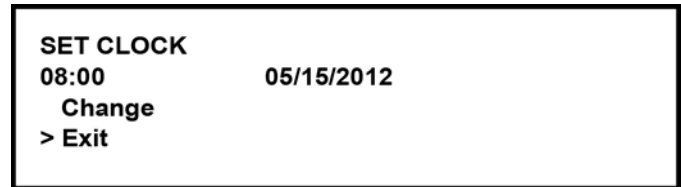

To change the date or time, select the SET CLOCK option in the menu. Press the Auto key  to advance the cursor from Exit to Change, then press the Calibration key  to select the Change option.



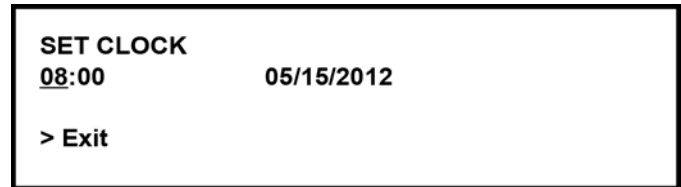

Change the time by pressing the Auto  or Flavor



Selection key  with the cursor under the hour position. Move the cursor to the minutes by selecting the Calibration key . Once the correct minutes are entered, select the Calibration key  to advance the cursor to the month.





Enter the correct month, day, and year. Then select the Calibration key  to advance to the DAYLIGHT SAVING TIME screen.



To disable the DAYLIGHT SAVING TIME feature, select the Auto key  to move the cursor to Disable. Press the Calibration key  to save the selection.

To enable the daylight saving time feature, select the Auto key  to move the cursor to Enable. Press the Calibration key  to save the selection.

The daylight saving time feature, when enabled, automatically adjusts the control clock for daylight saving time. Change the month and week for daylight saving time by selecting the Auto key  to advance the cursor from Exit to Change. Press the Calibration key  to select the Change option and move to the next screen.



Use the cursor keys to scroll to the appropriate month.

Press the Calibration key  to accept the selection.

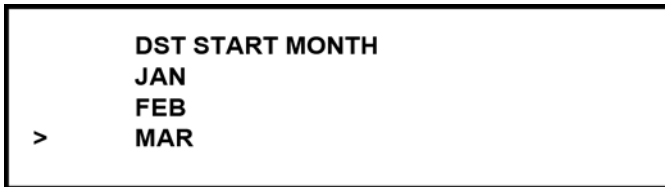

Once the appropriate month has been entered, scroll to the appropriate week. Press the Calibration key  to accept the selection.



Note: Scroll down to see selections *FOURTH SUNDAY* and *LAST SUNDAY*.

Select the month that daylight saving time will end. Press the Calibration key  to accept the selection.



Select the appropriate week that daylight saving time will end. Press the Calibration key  to accept the selection.





Select the Calibration key  to exit the screen and return to the Menu.

AUTO HEAT TIME





The AUTO HEAT TIME screen allows the manager to set the time of day in which the heat treatment cycle will start.

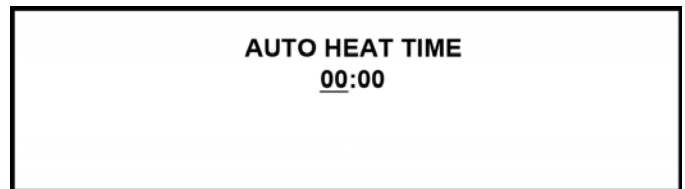

Note: Do not advance the AUTO HEAT TIME setting except on the day the machine is brush-cleaned. Increasing the time between heat cycles will cause the machine to soft lock if the start of the cycle does not begin within 24 hours from the start of the previous heat treatment cycle.

To set the AUTO HEAT TIME, select the Auto key  to move the cursor to Change. Then select the Calibration key . The screen will display the time with the cursor under the hour position.



Select the Auto key  or the Flavor Selection key  to increase or decrease the hour to the desired setting. Then move the cursor to the minutes position by selecting the Calibration key . Adjust the setting for minutes, then select the Calibration key  to save the setting and return to the AUTO HEAT TIME screen.



Select the Calibration key  to exit the screen and return to the Menu.

AUTO START TIME



The AUTO START TIME option allows the manager to set the time of day at which the machine automatically enters the Auto mode from the Standby mode. The machine must be in the Standby mode without a freezer lock condition in order to Auto start at the programmable time. The AUTO START TIME can also be disabled and require starting the Auto mode manually.

5





Enable the AUTO START TIME by selecting the Auto key  to move the cursor up to Enable. Select the Calibration key  to advance to the next screen.

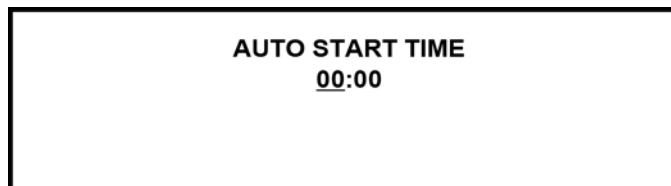

Program the AUTO START TIME by selecting the Auto key  to move the cursor to Change. Select the Calibration key  to advance to the next screen.



Program the AUTO START TIME by increasing (Auto key ) or decreasing (Flavor Selection key ) the hour setting above the cursor. Select the Calibration key  to advance the cursor and program the minutes setting.



Select the Calibration key  to return to the previous screen with the new time setting displayed.

Select the Calibration key  to exit the screen and return to the Menu.

STANDBY MODE

The STANDBY MODE option is used only on models which have the control panel Standby keys disabled.

The Standby option is used to manually place the left or right side in the Standby mode during long, no draw periods. Select the Standby screen from the Menu.

Select the Auto key  to move the cursor up to the left (shake) or right (soft serve) side. Select the Calibration key  to activate Standby for the selected side.

Repeat the steps to activate Standby on the remaining side.







Discontinue Standby operation for either side by exiting the Manager's Menu and selecting the Auto mode.

BRUSH CLEAN CYCLE

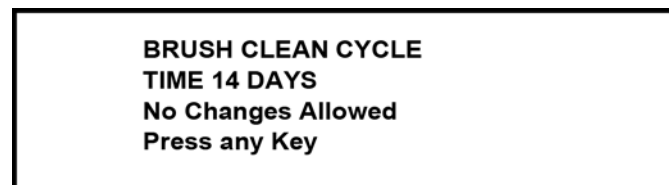
The BRUSH CLEAN CYCLE option allows the manager to select the maximum number of days between brush-cleaning the machine. The brush-clean cycle may be changed only after the freezer has been manually cleaned and before it has been placed in the Auto or Standby mode.

The following message will be displayed if the BRUSH CLEAN CYCLE option is selected when the machine is not in a brush-clean state:



Change the number of days between brush-clean intervals by selecting the Auto key  to decrease the number of days or the Flavor Selection key  to increase the number of days. Select the Calibration key  to save the setting and return to the Menu. The number of days displayed on the brush-clean counter will change to the new setting.

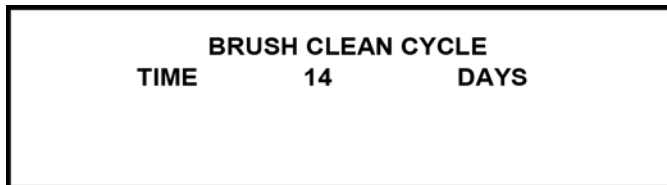



Always comply with local guidelines on the number of days allowed between brush-clean cycles.

MIX LEVEL AUDIBLE

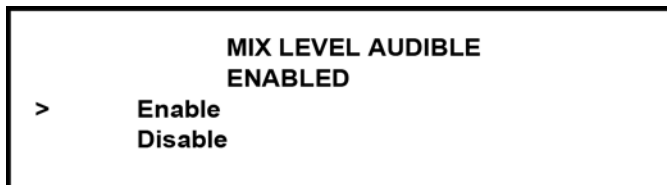
The MIX LEVEL AUDIBLE option, when enabled, will alert the operator with an audible tone when there is a mix low or mix out condition. The following screen is displayed upon selecting this option:





Disable the audible tone feature by selecting the Auto key  to move the cursor to Disable. Select the Calibration key  to save the new setting and return to the Menu. The control panel indicator lights for Mix Low and Mix Out will illuminate as the mix level drops in the hopper, but the audible tone will be disabled.

FAULT DESCRIPTION

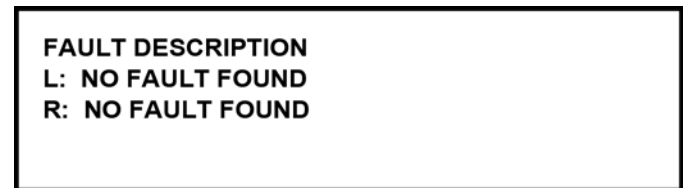
The FAULT DESCRIPTION display will indicate a fault with the freezer and the side of the freezer where the fault occurred. When no faults are detected, the following screen will be displayed:



Select the Calibration key  to display the next fault found or return to the Menu if no other faults exist.

Selecting the Calibration key  when faults are displayed will clear the corrected faults if corrected, upon returning to the Menu screen.

Listed below are the variable messages that will appear, along with an explanation for the corrective action.

NO FAULT FOUND—There was no fault found in the freezer. Nothing will appear on the screen after this variable message appears.

BEATER OVERLOAD—Press the beater reset button firmly on the side of the freezer with the fault.

HPCO COMPRESSOR—Place the power switch in the OFF position. Wait 5 minutes for the machine to cool. Place the power switch in the ON position and restart each side in Auto.

HOPPER THERMISTOR BAD—Place the power switch in the OFF position. Call your authorized Taylor service technician.

HOPPER OVER TEMP—Place the power switch in the ON position and verify that the Auto or Standby key is illuminated.

BARREL OVER TEMP—Place the power switch in the ON position and verify that the Auto or Standby key is illuminated.

BARREL THERMISTOR BAD—Place the power switch in the OFF position. Call your authorized Taylor service technician.

GLYCOL THERMISTOR BAD—Place the power switch in the OFF position. Call your authorized Taylor service technician.

PRODUCT DOOR OFF—Place the power switch in the OFF position. Make sure that the dispensing door is properly installed and that the handscrews are tight.

COMP ON TOO LONG—The compressor ran more than 11 consecutive minutes without the product reaching set point temperature. Clean the condenser filter, replace the scraper blades, and reprime the machine using **fresh** mix. If the fault appears again, call your authorized Taylor service technician.



LOCKOUT HISTORY

The LOCKOUT HISTORY screen displays a history of the last 100 soft locks, hard locks, brush-clean dates, or aborted heat cycles. Page numbers are indicated in the upper right hand corner. Page 1 always contains the most recent failure.

LOCKOUT HISTORY		2
00/00/00	00:00	
Reason		
> Exit		

The second line of the screen displays the date and time a failure occurs. The third line indicates the reason for a failure, or will indicate if a successful brush-cleaning has occurred. Some failures occur with multiple reasons.

5 When this occurs, a page will be generated for each reason.

Select the Auto key  or Flavor Selection key  to advance forward or backward to view each screen.

Faults Occurring Entering a Heat Treatment Cycle

POWER SWITCH OFF—The power switch is off.

AUTO OR STBY OFF—The control was not in Auto or Standby mode.

MIX OUT FAILURE—A mix out condition was present.

NO HEAT CYCLE TRIED—The Auto Heat Time was set to attempt a heat cycle for more than 24 hours after the last successful heat cycle.

Faults Occurring While in the Heat Mode

HEAT MODE FAILURE—The 90-minute maximum allowable heat mode time was exceeded.

COOL MODE FAILURE—The 120-minute maximum allowable cool mode time was exceeded.

TOTAL TIME FAILURE—The 4-hour maximum allowable total heat treatment time was exceeded.

BRUSH CLEAN TIMEOUT—The total days in operation exceeded the brush-clean cycle setting.

POWER SWITCH OFF—The power switch was turned off during the heat cycle.

POWER FAIL IN H/C—A power failure occurred during the heat treatment cycle.

(L/R) MIX LOW FAILURE—The mix level in the (left/right) hopper is too low for a successful heat cycle.

(L/R) BEATER OVLD H/C—The overload tripped for the (left/right) side beater motor.

(L/R) BRL THERM FAIL—The thermistor sensor for the (left/right) side barrel failed.

(L/R) HOPPER THERM FAIL—The thermistor sensor for the (left/right) side hopper failed.

(L/R) HPCO H/C—The (left/right) side high-pressure switch opened during the heat treatment cycle.

Faults Occurring While in Auto Mode

(L/R) HPR>41°F (5°C) AFTER 4 HR—The mix temperature in the left or right hopper was above 41°F (5°C) for more than 4 hours.

(L/R) BRL>41°F (5°C) AFTER 4 HR—The mix temperature in the left or right barrel was above 41°F (5°C) for more than 4 hours.

(L/R) HPR>45°F (7°C) AFTER 1 HR—The mix temperature in the left or right hopper was above 45°F (7°C) for more than 1 hour.

(L/R) BRL>45°F (7°C) AFTER 1 HR—The mix temperature in the left or right barrel was above 45°F (7°C) for more than 1 hour.

(L/R) HPR>41°F (5°C) AFTER PF—The mix temperature in the left or right hopper was above 41°F (5°C) for more than 4 hours following a power failure.

(L/R) BRL>41°F (5°C) AFTER PF—The mix temperature in the left or right barrel was above 41°F (5°C) for more than 4 hours following a power failure.

(L/R) HPR>59°F (15°C)—The mix temperature in the left or right hopper exceeded 59°F (15°C).

(L/R) BRL>59°F (15°C)—The mix temperature in the left or right barrel exceeded 59°F (15°C).

FAULT HISTORY

The FAULT HISTORY screens will display up to 100 faults that have occurred. The most recent fault is displayed on screen 1. The date, time, and fault description is displayed on each screen.



Advance to the next most recent occurring fault by selecting the Auto key . Scroll through the screens in the opposite direction by selecting the Flavor Selection key . Exit the FAULT HISTORY screen and return to the menu by selecting the Calibration key .

Fault Descriptions

(L/R) Comp On Too Long—The left or right main compressor has run for more than 11 consecutive minutes without dispensing product.

(L/R) Product Door Off—The left or right freezer door is not completely installed, or the safety interlock circuit has opened.

(L/R) Hopper Therm Bad—The left or right hopper thermistor probe is **shorted** or **open**.

(L/R) Hopper Over Temp—The left or right hopper thermistor probe is reading over 200°F (93°C).

(L/R) Barrel Over Temp—The left or right barrel thermistor probe is reading over 200°F (93°C).

(L/R) Beater Overload—The left or right reset mechanism has tripped.

(L/R) HPCO Compressor—The left or right high-pressure switch contacts have opened.

(L/R) Glycol Therm Bad—The left or right glycol thermistor probe is reading over 200°F (93°C).

HEAT CYCLE SUMMARY

The HEAT CYCLE SUMMARY screen displays the hours since the last heat cycle, the hours since the product temperature was above 150°F (65.6°C), and the number of heat cycles completed since the last brush-clean date.



HEAT TREAT CYCLE

The HEAT TREAT CYCLE screen contains a record of up to 366 heat treatment cycles. The most recent heat cycle data will be shown first. The Standard records have each heat cycle recorded in three screens. Select the Auto key to move the cursor to Standard records and select the Calibration key .



The first screen displays the month and day of the heat cycle, the start time and end time, and the fault description. The bottom line displays the record number and indicates if a power failure occurred during the heat cycle (POWER FAILURE IN HC).



Select the Auto key to advance forward through the data pages. Select the Flavor Selection key to reverse the page direction.

USER INTERFACE

Hopper and barrel temperature records for each side of the freezer are displayed on the second and third screens. The second screen shows the left side (L) side of the freezer.

H: 40.9	B:26.3	L
HEAT OVER	COOL PEAK	
1:12 0:49	h 1:19 161.0	
0:46 1.11	b 0:15 169.7	

The third screen shows the right side (R) of the freezer.

H: 38.0	B:23.7	R
HEAT OVER	COOL PEAK	
1:09 0:52	h 1:11 161.2	
0:66 1.00	b 0:15 169.9	

The top line of these screens shows the hopper (h) and barrel (b) temperatures recorded at the end of the heat treat cycle and indicates the side (L or R) of the freezer.

The remaining lines indicate the following:



5 **HEAT** = Total time for the hopper (h) and barrel (b) to reach 150.9°F (66.1°C).

OVER = Total time the hopper (h) and barrel (b) temperature was above 150°F (65.6°C).

COOL = Total time the hopper (h) and barrel (b) temperature was above 41°F (5°C) during the COOL phase.

PEAK = Highest temperature reading for the hopper (h) and barrel (b) during the heat treatment cycle.

The HEAT time indicates the amount of time taken in each zone to reach 150.9°F (66.1°C). Each zone must remain above 150°F (65.6°C) for a minimum of 35 minutes. In addition, each zone must be heated for a minimum of 115 minutes.

Select the Auto key  to advance to the next page or the Flavor Selection key  to view the previous page.

A Heat Cycle Failure message will display on the first screen if a failure occurred.

Listed below are variable failure code messages which could appear on line 2.

Table 5-2

HT	HEAT TIME FAILURE Mix temperature did not rise above 151°F (66.1°C) in less than 90 minutes.
----	---



CL	COOL MODE FAILURE Mix temperature in the hopper and freezing cylinder did not fall below 41°F (5°C) in less than 120 minutes.
TT	TOTAL TIME FAILURE The heat treatment cycle must be completed in no more than 4 hours.
MO	MIX OUT FAILURE A mix out condition was detected at the start or during the heat cycle.
ML	MIX LOW FAILURE The Heat Phase or Cool Phase time was exceeded, and a mix low condition was present.
BO	BEATER OLVD IN HC A beater overload occurred during the heat cycle.
HO	HPCO IN HEAT CYCLE A high-pressure cut-out condition occurred during the heat cycle.
PF	POWER FAILURE IN HC A power failure caused the Heat Phase, Cool Phase, or Total Cycle Time to exceed the maximum allowed time. If a power failure occurs, but the heat treatment cycle does not fail, an asterisk(*) will appear on the third line of the display.
PS	POWER SWITCH OFF The power switch was placed into the OFF position during the heat treatment cycle.
TH	THERMISTOR FAILURE A thermistor probe has failed.
OP	OPERATOR INTERRUPT Indicates the heat treatment cycle was aborted in the OPERATOR INTERRUPT option in the Service Menu.
PD	PRODUCT DOOR OFF A product door is not in place or is loose.

The HEAT CYCLE DATA screen details the temperature in the freezing cylinders and mix hoppers every 5 minutes during the heat treatment cycle. Up to 366 heat treatment cycles are recorded. The time and temperature is displayed for the left hopper, left barrel, right hopper, and right barrel for each phase during the heat treat cycle. An individual phase or a complete heat treat cycle containing all four phases can be viewed.

Heat Treatment Phases



Table 5-3

HEAT	The phase that heats the mix in the barrels and hoppers to 151°F (66.1°C).
HOLD	The phase that maintains the mix temperature above 151°F (66.1°C) for a minimum of 30 consecutive minutes.
SOAK	The additional heating time that may follow the HOLD phase to ensure the total HEAT, HOLD, and SOAK time is not less than 115 minutes.
COOL	The phase that refrigerates the mix until all four temperature zones are cooled below 41°F (5°C).

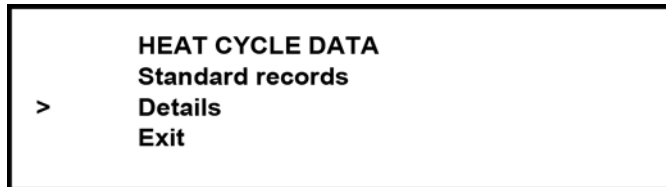
In the HEAT CYCLE DATA screen, select the Auto key  to move the cursor up to Details, and then select the Calibration key .



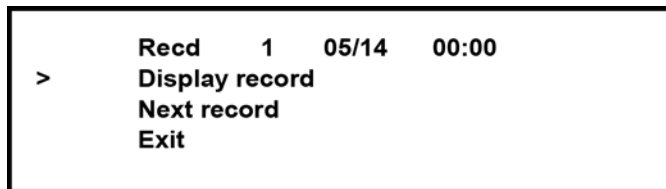

The most recent heat treatment cycle record (Recd 1) is displayed with the date and time. Access a different heat treatment cycle record by selecting the Flavor Selection

key  to move the cursor to Next record, and select the Calibration key . Repeat this step until the desired record with the date and time is displayed.

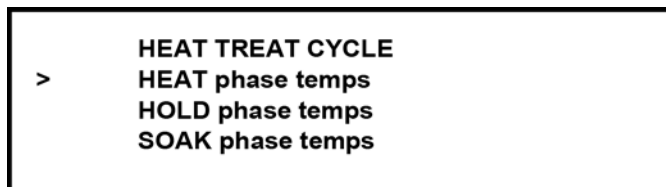

With the cursor on the Display record line, select the Calibration key .



Select the Flavor Selection key  to scroll down to the phase to be reviewed. Selecting ALL phase temps will display all four phases of the heat treat cycle record in sequential order.



The four temperature readings are recorded at the same time on individual screens. Align the cursor with the phase to be reviewed and select the Calibration

key .

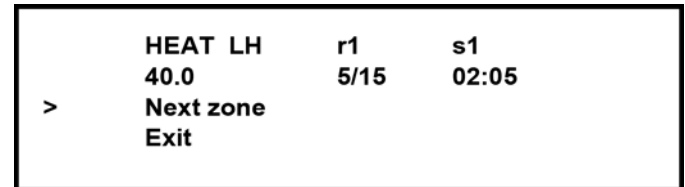

5

Table 5-4

Line 1	Displays the Phase	Heat / Hold / Soak / Cool
	LH	Left Hopper
	r 1	Record Number
	s 1	Sample Number
Line 2	Zone Temperature	
	Date and Time Temperature was recorded.	

Note: An L or an H displayed to the left of the temperature reading indicates the temperature was the lowest or highest recorded during the phase.

USER INTERFACE

Selecting the Calibration key  will advance the screen to the next zone. The second temperature zone displayed is the left barrel (LB).

	HEAT LB	r1	s1
	25.4	5/15	02:05
>	Next zone		
	Exit		

Figure 5-7

Select the Calibration key  to advance to the next temperature zone: the right hopper (RH).

	HEAT RH	r1	s1
	39.5	5/15	02:05
>	Next zone		
	Exit		

Figure 5-8

5 Select the Calibration key  to advance to the last temperature zone in the recorded sample: the right barrel (RB).

	HEAT RB	r1	s1
	26.5	5/15	02:05
>	Next sample		
	Exit		

Figure 5-9

Select the Calibration key  again to advance to the next sample. Each sample is displayed in 5-minute increments.

	HEAT LH	r1	s1
	46.4	5/15	02:10
>	Next zone		
	Exit		

When the final sample in the phase is displayed, the Heat Cycle results screen can be selected.

	HEAT RB	r1	s14
	H 169.0	5/15	
>	Result		
	Exit		

If the COOL data or All phase data were reviewed, the final temperature zone sample in the record will be displayed with the selection for the result screen.

	COOL RB	r14	s42
	20.0	5/15	04:15
>	Result		
	Exit		

Select the Calibration key  to view the Heat Cycle results screen.

	PASS	r1	s43
	Heat Cycle results		
>	Next record		
	Exit		

To view the details for the same phase in the preceding record (Next record), select the Calibration key . If All phase data was selected, the record number will remain the same and the next phase sample will be displayed.

	HOLD LH	r1	s16
	158.7	5/15	04:15
>	Next zone		
	Exit		

Exit the record screens by moving the cursor to Exit and select the Calibration key .

The average heat treatment cycle will contain approximately 40 samples of the four temperature zone screens.

SYSTEM INFORMATION

The SYSTEM INFORMATION is displayed on four separate screens. The first screen contains the control and software version installed in the machine.

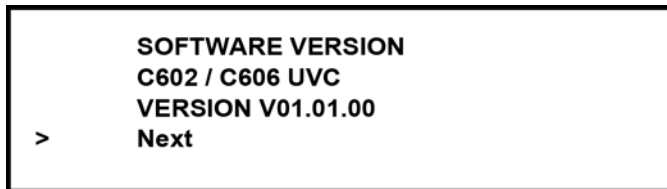

Select the Calibration key  to advance to the next system information screen containing the software language version.

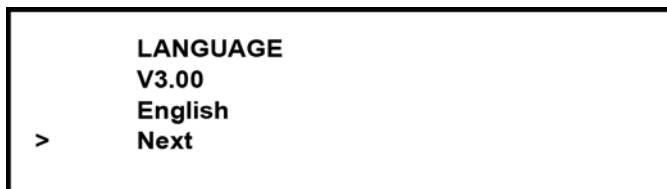

For UVC4 models only, select the Calibration key  to advance to the third system information screen containing the Boot loader version.

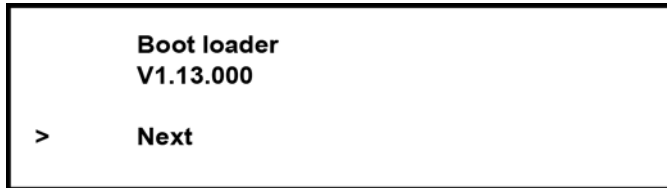

Select the Calibration key  to advance to the last system information screen containing the model bill of material (B.O.M.) and machine serial number.

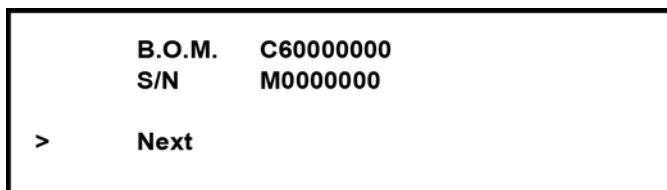

Selecting the Calibration key  again will return to the Menu list.

Note: In order to display the machine details in the system information screen, the model and serial number information must have been previously entered into the EDIT UNIT ID screens in the Service Menu.

CURRENT CONDITIONS

The CURRENT CONDITIONS screen provides the viscosity readings for the product when the machine is running and provides the hopper and barrel temperatures for both sides of the machine. The left column displays the readings for the shake side, and the right column displays the soft serve side readings.

VISC	0	0.0
HOPPER	38.0	38.0
BARREL	25.0	18.0

CURRENT CONDITIONS is the only Menu screen that will return the left and right side control panel keys to normal operation. The Menu keys will not be lit when this option is selected, so shakes can be dispensed and all panel press keys are fully functional. Use this screen when you wish to remain in the Manager's Menu and dispense a shake.

Exit the CURRENT CONDITIONS screen and return to the Menu by selecting the Calibration key .

Dispensing Shake without Syrup

Beginning with software version 1.04, shakes can be dispensed without flavoring by selecting the left side

Pump key .

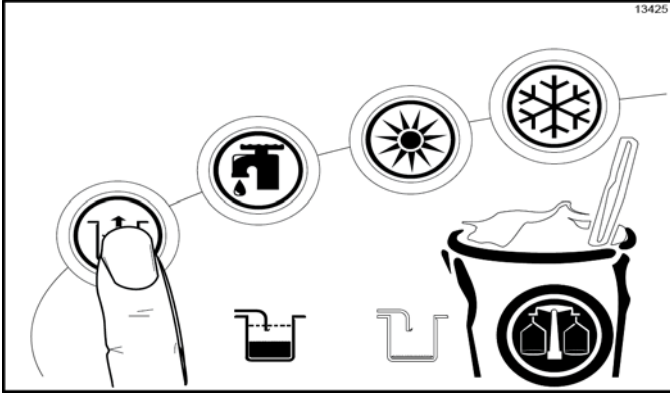
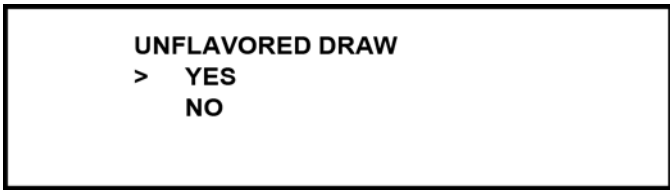



Figure 5-10

The following screen will display:



5

Select the Calibration key . The left side Pump key illuminates, and unflavored product immediately starts to dispense. The unflavored draw ends, and the Pump key light turns off when the pyroelectric sensor detects the cup is full. The unflavored draw can also be terminated by selecting the Pump key a second time.

Note: To cancel the UNFLAVORED DRAW screen, press the Flavor Selection key to move the cursor to NO, and select the Calibration key .

Section 6

Operating Procedures

If you are disassembling the machine for the first time or need information to get to this starting point in our instructions, see Disassembly—Shake Side on page 6-34 and Disassembly—Soft Serve Side on page 6-35.

Machine Setup

Freezing Cylinder Assembly—Shake Side



WARNING! Make sure the control switch is in the Off position to eliminate the chance of moving parts. Failure to follow this instruction may result in severe personal injury from hazardous moving parts.

Setup using the parts tray for the shake side.

1. Lubricate the groove on the shake beater driveshaft before installing. Slide the beater driveshaft boot seal over the small end of the beater driveshaft and engage it into the groove on the shaft. Heavily lubricate the inside portion of the boot seal and also lubricate the flat end of the boot seal that comes in contact with the rear shell bearing. Apply an even coat of lubricant to the shaft. **Do not** lubricate the square end. (See Figure 6-1.)

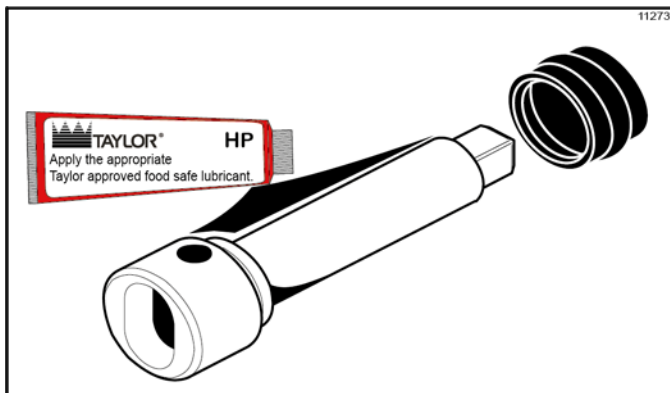

Figure 6-1

Note: When lubricating parts, use an approved food grade lubricant (example: Taylor Lube HP).

Note: To ensure that the mix does not leak out of the back of the freezing cylinder, the middle section of the boot seal should be convex or extend from the seal. If the middle section of the boot seal is concave or extending into the middle of the seal, turn the seal inside out. (See Figure 6-2.)

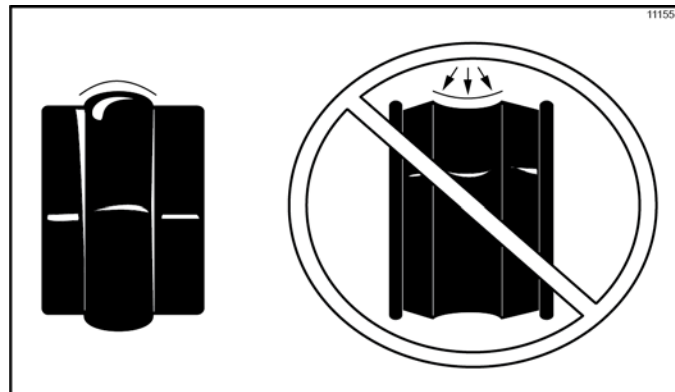

Figure 6-2

2. Install the shake beater driveshaft through the rear shell bearing in the freezing cylinder and engage the square end firmly into the driveshaft coupling. Make sure the driveshaft fits into the drive coupling without binding. (See Figure 6-3.)

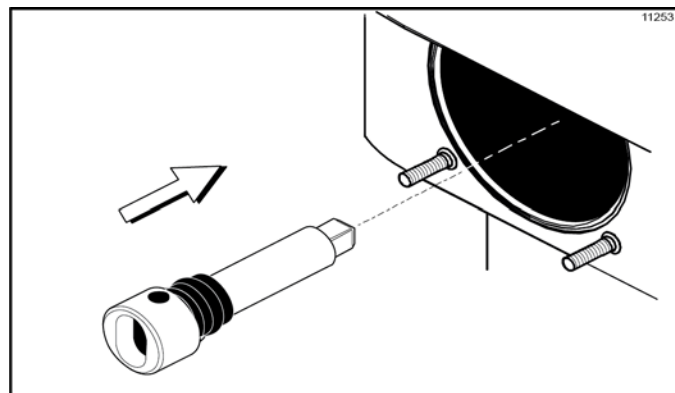

Figure 6-3

3. Check scraper blades for nicks or signs of wear. If any nicks are present, replace the blades.

Note: Shake side scraper blades should be replaced every 6 months.

4. If the blades are in good condition, place each scraper blade over the holding pins on the beater assembly. (See Figure 6-4.)

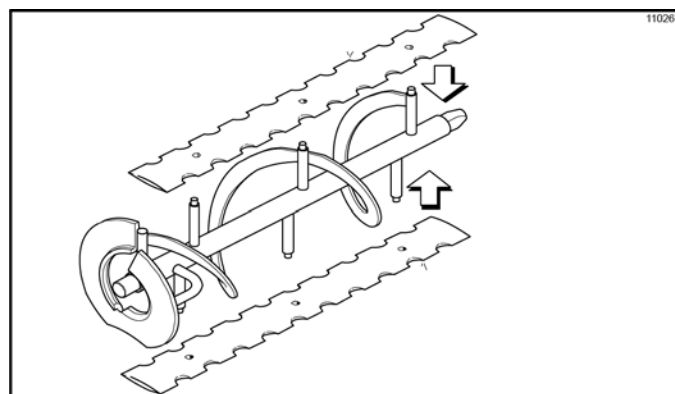

Figure 6-4

OPERATING PROCEDURES

Note: The holes in the scraper blade must fit over the pins to prevent damage.

5. Holding the blades on the beater assembly, insert the beater assembly in the freezing cylinder. Engage the shaft end firmly into the driveshaft socket. (See Figure 6-5.)

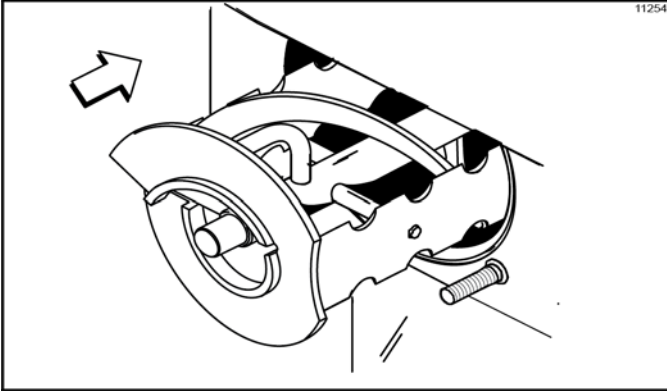

Figure 6-5

Note: When properly seated, the beater will not protrude beyond the front of the freezing cylinder.

6. Assemble the draw valve spinner assembly. Inspect draw valve O-rings and replace if cut or nicked. If draw valve O-rings are in good condition, slide the two O-rings into the grooves of the draw valve and lubricate. (See Figure 6-6.)

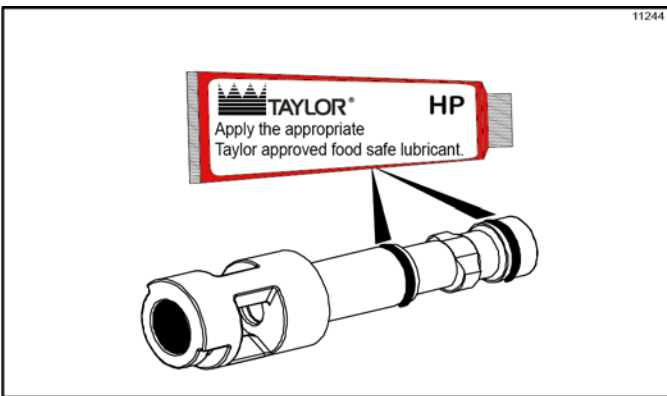

Figure 6-6

7. Lubricate the outer diameter of the spinner shaft seal. Fill the cups on each end of the seal with lubricant.

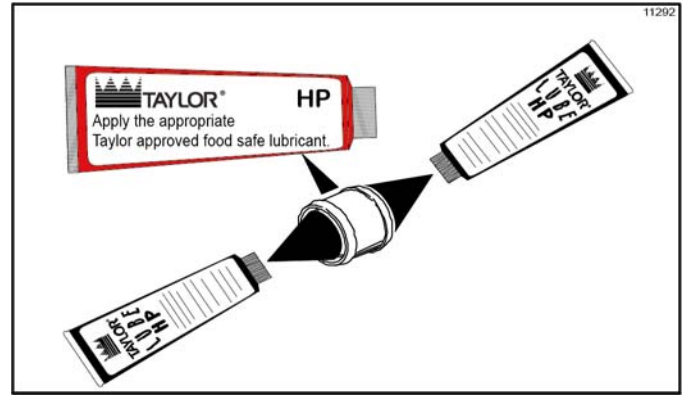

Figure 6-7

8. Insert the spinner shaft seal into the bottom of the draw valve as far as it will go. The spinner shaft seal should fit into the seal groove located inside the draw valve cavity.

Important! Inspect to see that the spinner shaft seal is correctly installed in the groove. A worn, missing, or improperly installed spinner shaft seal will cause product leakage out the top of the draw valve. (See Figure 6-8.)

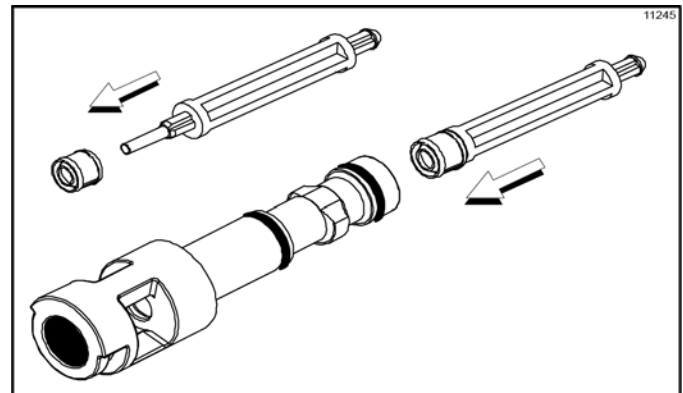

Figure 6-8

9. Lubricate the smaller end of the driven spinner. (See Figure 6-9.)

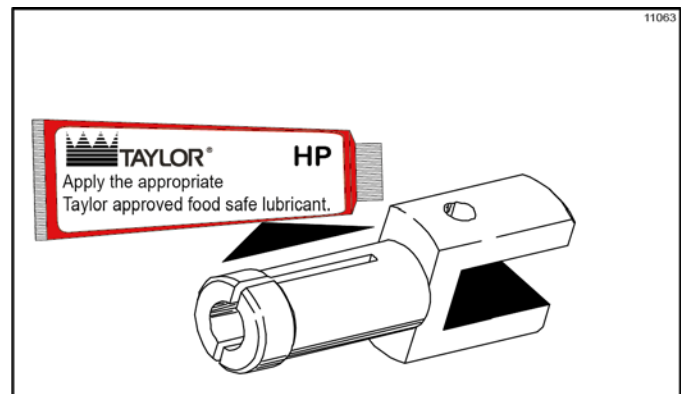

Figure 6-9

10. Squeezing the split end, insert the driven spinner through the metal opening of the draw valve until it snaps into place. (See Figure 6-10.)

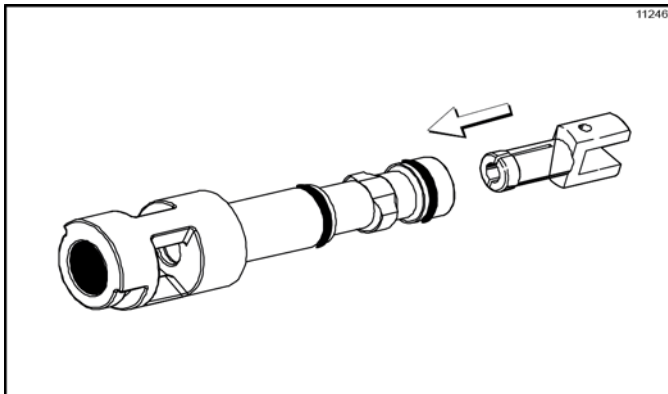

Figure 6-10

11. Insert and align the draw valve spinner assembly into the shake door as shown. (See Figure 6-11.)

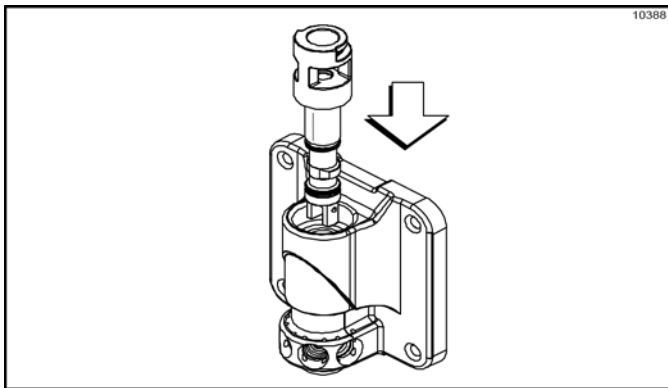

Figure 6-11

12. Place the freezer door O-ring into the groove on the back of the freezer door. Lubricate the outside diameter of the front bearing. Slide the front bearing into the door hub.

Note: If necessary, put two small spots of lubricant at the 10 o'clock and 2 o'clock positions on the freezer door O-ring to keep it in place.

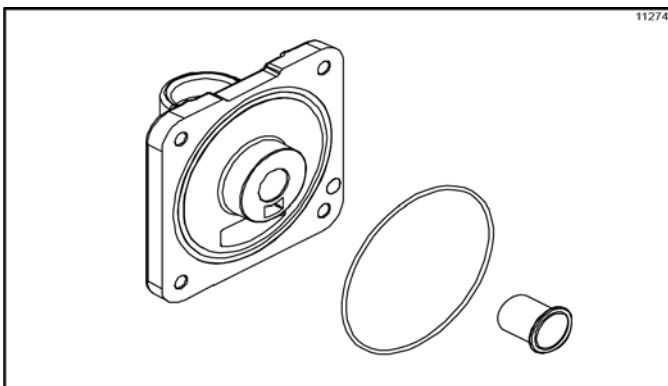

Figure 6-12

13. Install the shake freezer door. Position the freezer door on the four studs on the front of the freezing cylinder. Align the top of the draw valve with the actuator bracket. Install the handscrews (short handscrews at the bottom of the door). Tighten equally in a crisscross pattern to ensure the door is secured. **Do not overtighten.**

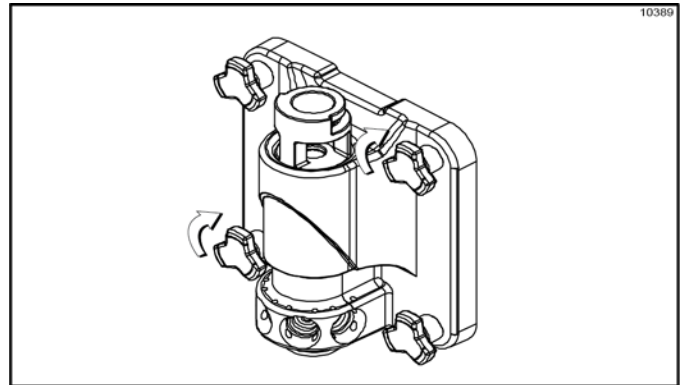

Figure 6-13

14. Lubricate the shaft of the spinner blade up to the groove. (See Figure 6-14.)

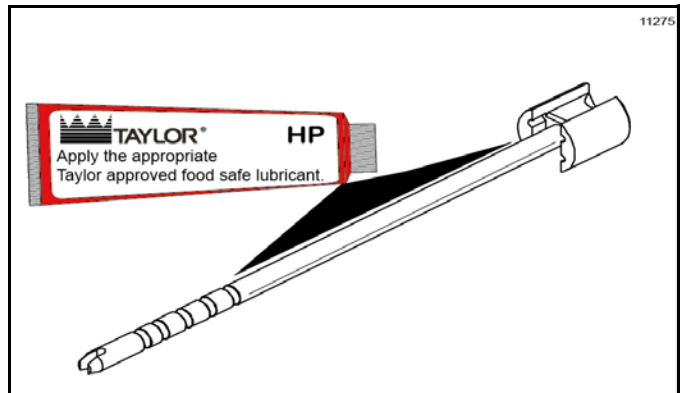

Figure 6-14

15. Insert the spinner blade shaft into the center of the driven spinner and through the draw valve cavity until the shaft appears at the top of the draw valve. The spinner blade must be aligned and engaged to the driven spinner at the bottom. This allows the spinner shaft to be raised high enough to be engaged into the spinner coupling at the top. (See Figure 6-15.)

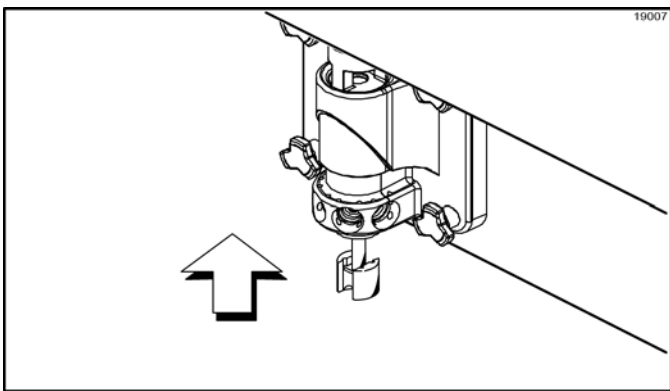

Figure 6-15

16. Raise the locking collar of the spinner coupling and insert the spinner shaft into the cavity of the coupling until the locking collar can drop into the locked position. (See Figure 6-16.)

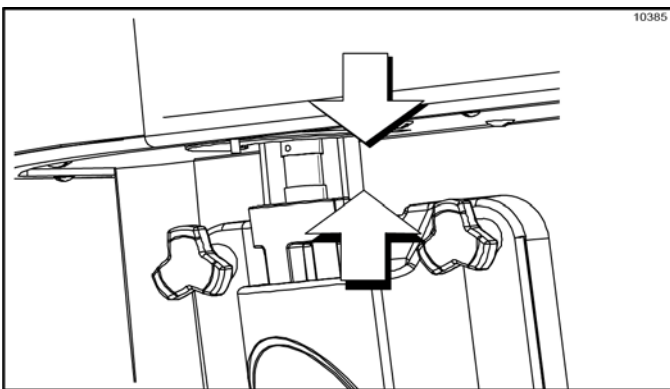

Figure 6-16

17. Snap the restrictor cap over the end of the door spout and install the syrup valve retainer pins. (See Figure 6-17.)

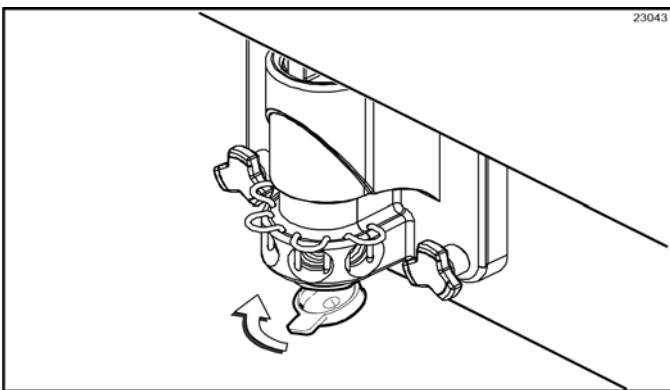

Figure 6-17

Freezing Cylinder Assembly—Soft Serve Side



WARNING! Make sure the control switch is in the Off position to eliminate the chance of moving parts. Failure to follow this instruction may result in severe personal injury from hazardous moving parts.

Setup using the parts tray for the soft serve side.

1. Lubricate the groove on the soft serve beater driveshaft before installing. Slide the beater driveshaft boot seal over the small end of the beater driveshaft and engage into the groove on the shaft. Heavily lubricate the inside portion of the boot seal and lubricate the flat end of the boot seal that comes in contact with the rear shell bearing. Apply an even coat of lubricant to the shaft. **Do not** lubricate the hex end. (See Figure 6-18.)

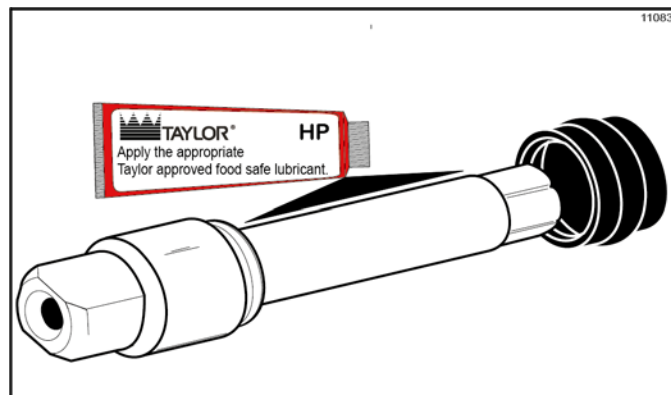

Figure 6-18

Note: When lubricating parts, use an approved food grade lubricant (example: Taylor Lube HP).

Note: To ensure the mix does not leak from the back of the freezing cylinder, the middle section of the boot seal should be convex or extend from the seal. If the middle section of the boot seal is concave or extending into the middle of the seal, turn the seal inside out. (See Figure 6-19.)

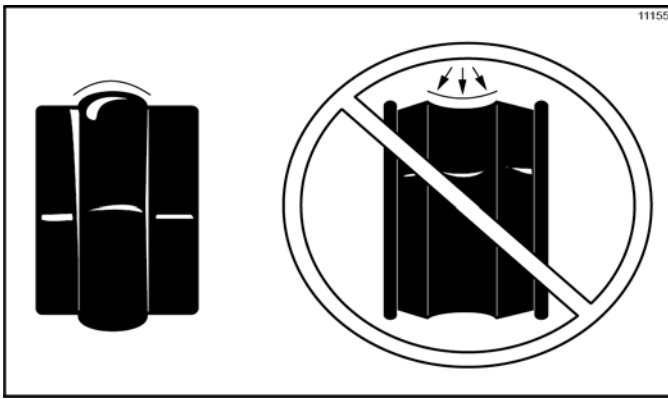

Figure 6-19

2. Insert the beater driveshaft through the rear shell bearing in the freezing cylinder and engage the hex end firmly into the drive coupling. (See Figure 6-20.)

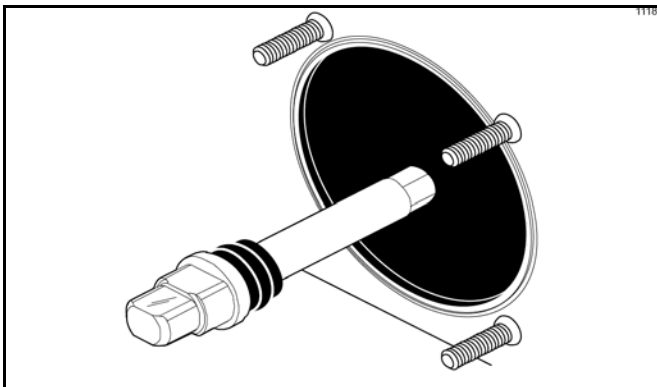

Figure 6-20



WARNING! Use extreme caution when handling the beater assembly. The scraper blades are very sharp and may cause injury.

3. Before installing the beater assembly, inspect the scraper blades for any signs of wear or damage. If a scraper blade is nicked or worn, replace both blades.

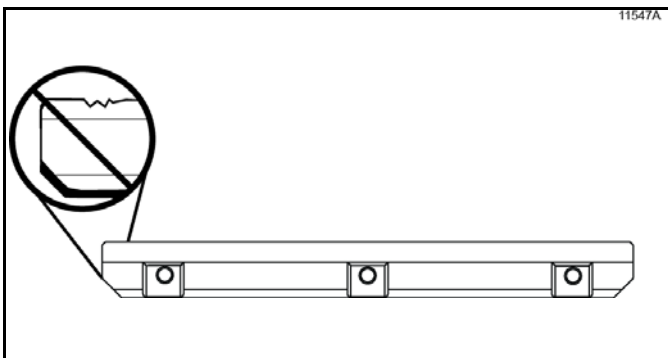

Figure 6-21

4. If the blades are in good condition, place the rear scraper blade over the rear holding pin on the beater.

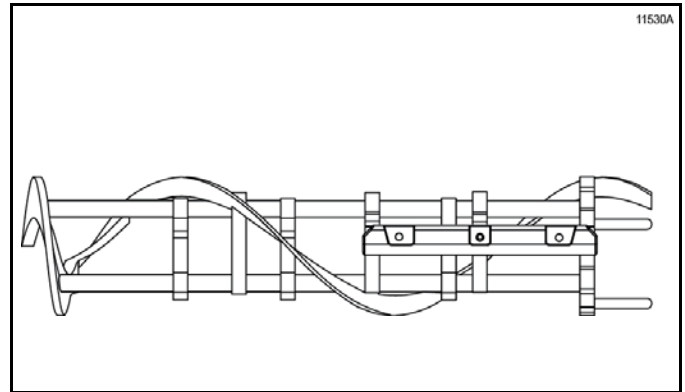

Figure 6-22

Note: Soft serve side scraper blades should be replaced every 3 months.

Note: The hole on the scraper blade must fit securely over the pin to prevent costly damage.

5. Holding the rear blade on the beater, slide it into the freezing cylinder halfway. Install the front scraper blade over the front holding pin. (See Figure 6-23.)

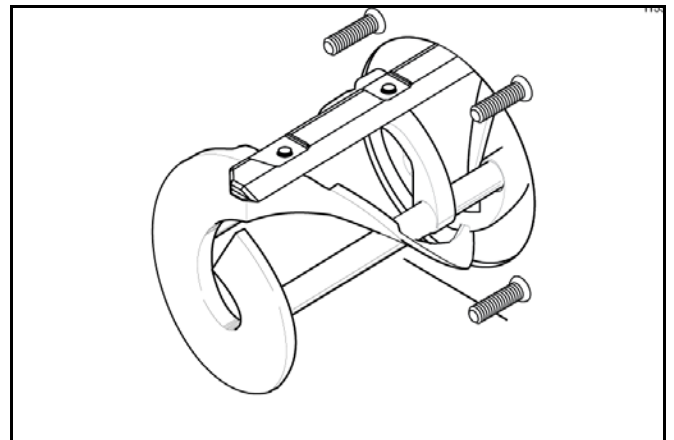

Figure 6-23

6. Before installing the beater shoes, check the shoes for any nicks, cracks, or signs of wear. If any defects are present, replace the beater shoes.

OPERATING PROCEDURES

7. Install the beater shoes. (See Figure 6-24.)

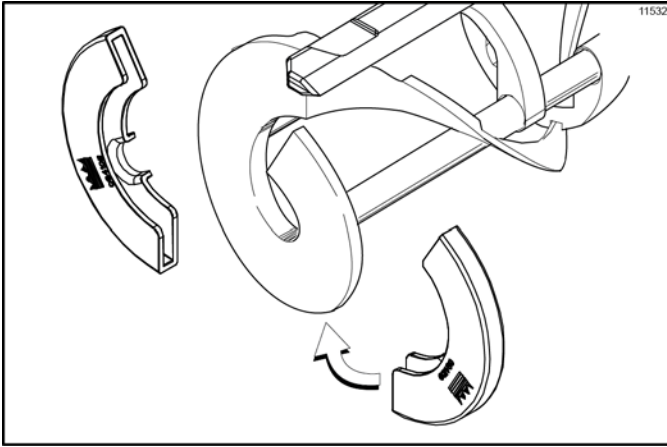

Figure 6-24

8. Slide the beater assembly the rest of the way into the freezing cylinder. Make sure the beater assembly is in position over the driveshaft by turning the beater slightly until the beater is properly seated. When in position, the beater will not protrude beyond the front of the freezing cylinder. (See Figure 6-25.)

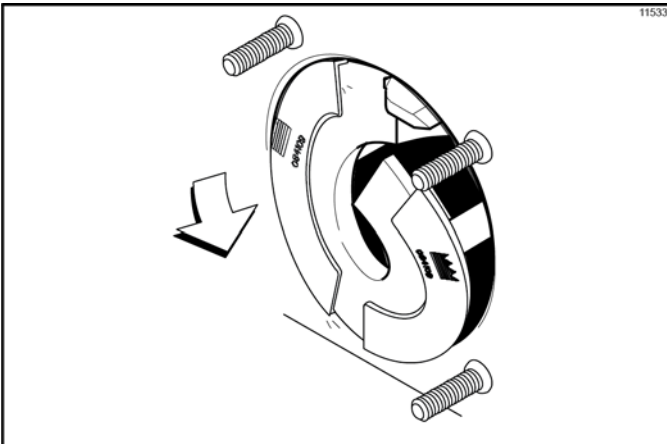

Figure 6-25

9. Before assembling the freezer door, check the following for any nicks, cracks, or signs of wear: the door bearing, door gasket, draw valve, O-rings, and all sides of the door assembly, including the draw valve bore. Replace any damaged parts.

10. If the parts are in good condition, slide the three O-rings into the grooves on the draw valve and lubricate them. (See Figure 6-26.)

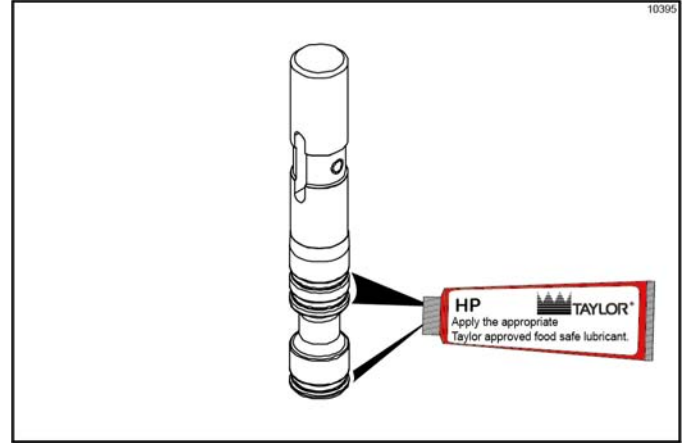

Figure 6-26

11. Lightly lubricate inside the top of the freezer door valve cavity. (See Figure 6-27.)

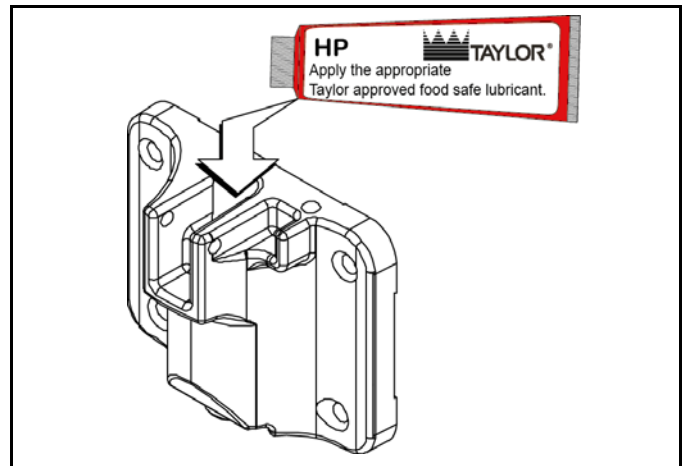

Figure 6-27

12. Insert the draw valve from the top, with the draw handle slot facing forward. (See Figure 6-28.)

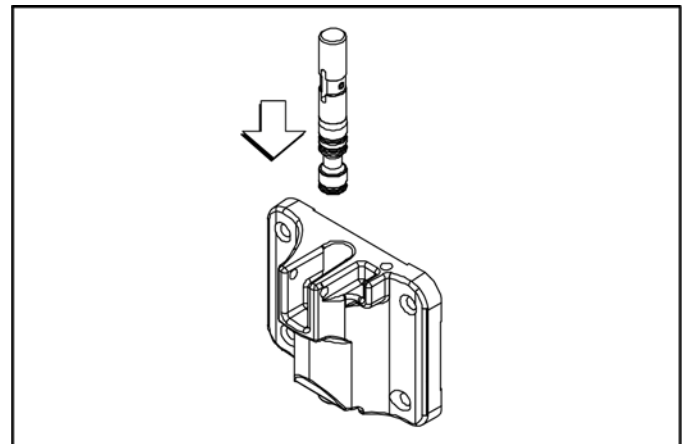

Figure 6-28

13. Place the door gasket into the groove on the back of the freezer door. Install baffle by raising round end while engaging lug into door pocket. Lower round end to secure to door. **Do not** lubricate the gasket. (See Figure 6-29.)

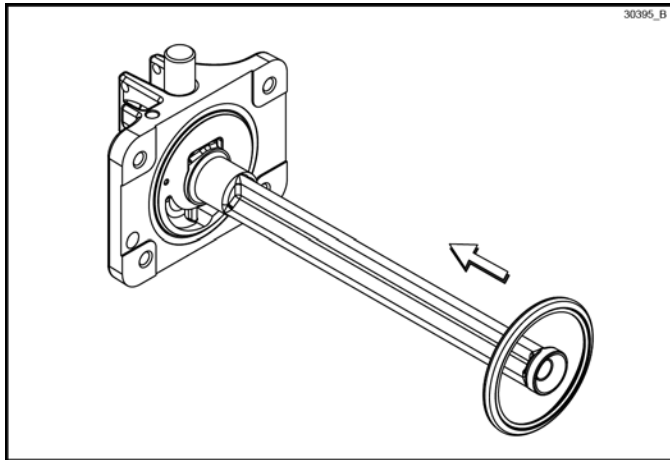

Figure 6-29

14. Insert the baffle rod through the beater in the freezing cylinder. With the door seated on the freezer studs, install the handscrews. Tighten them equally in a crisscross pattern to ensure the door is secured. (See Figure 6-30.)

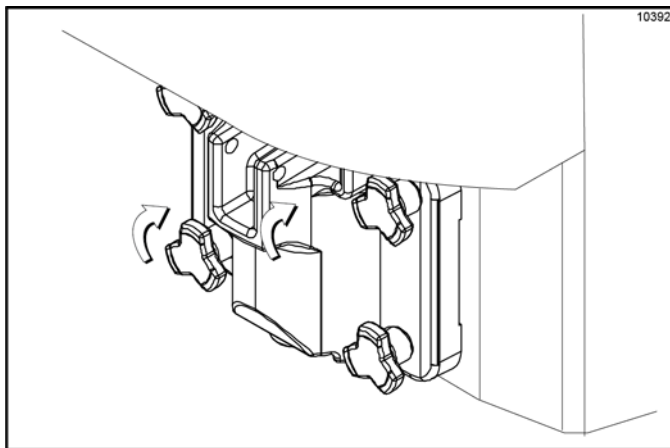

Figure 6-30

15. Install the draw handle. Slide the fork of the draw handle in the slot of the draw valve. Secure it with the pivot pin. (See Figure 6-31.)

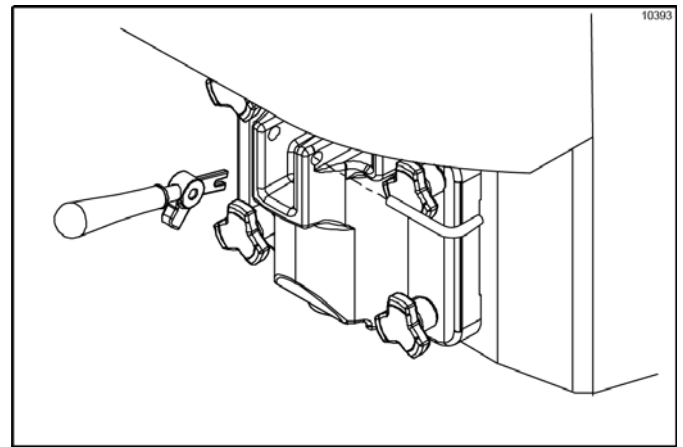

Figure 6-31

Note: The soft serve side features an adjustable draw handle to provide portion control, giving a more consistent quality to your product and controlling costs. The draw handle should be adjusted to provide a flow rate of 5 oz. to 7-1/2 oz. (142 g to 213 g) of product by weight per 10 seconds. To increase the flow rate, turn the adjustment screw clockwise. Turn the adjustment screw counterclockwise to decrease the flow rate.

16. Slide the long drip pan into the hole in the front panel above the syrup topping dispensers. (See Figure 6-32.)

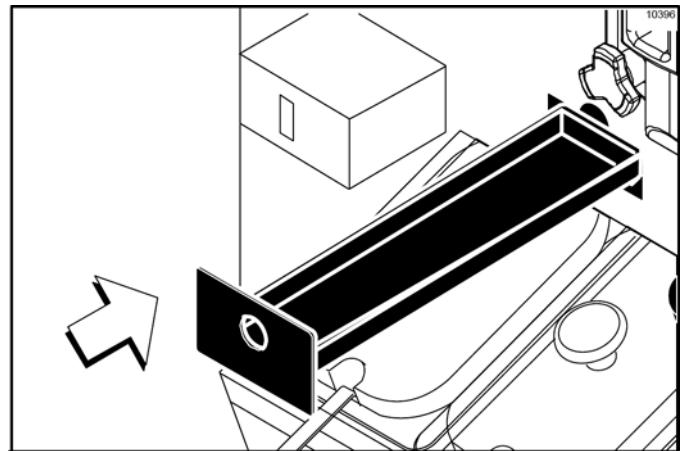

Figure 6-32

OPERATING PROCEDURES

17. Slide the two shorter drip pans into the holes in the rear panel. Slide the two notched drip pans into the left and right side panels. (See Figure 6-33.)

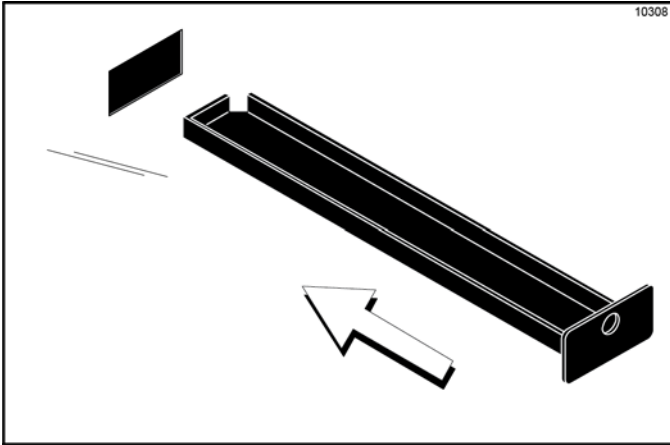

Figure 6-33

18. Install the front drip tray and splash shield under the door spouts. (See Figure 6-34.)

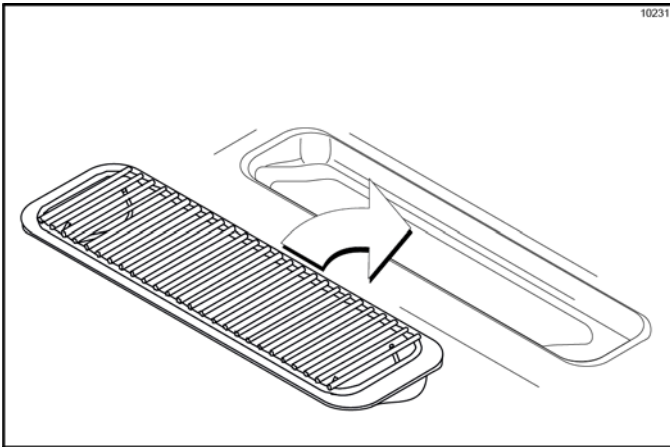

Figure 6-34

Mix Pump Assembly

1. Inspect the rubber and plastic pump parts. The O-rings, check rings, and gaskets must be in good condition for the pump and entire machine to operate properly. They cannot properly serve their intended function if nicks, cuts, or holes in the material are present.
- Inspect the plastic pump parts for cracks, wear, and delamination of plastic.
- Replace and discard any damaged parts immediately.

2. Assemble the piston. Slide the red O-ring into the groove of the piston. **Do not** lubricate the O-ring. (See Figure 6-35.)

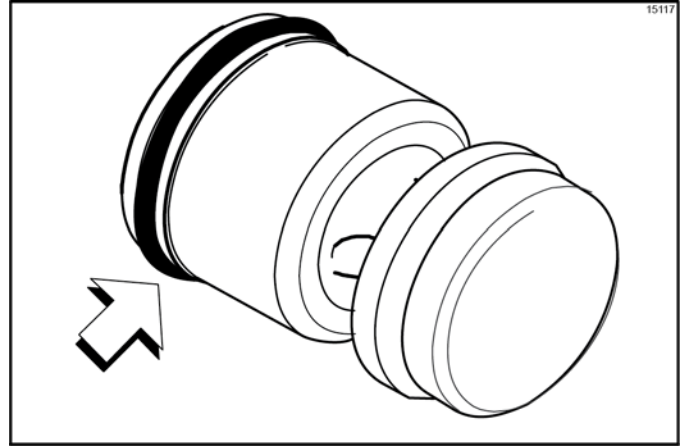

Figure 6-35

3. Apply a thin layer of lubricant to the inside of the pump cylinder at the retaining pin end. (See Figure 6-36.)

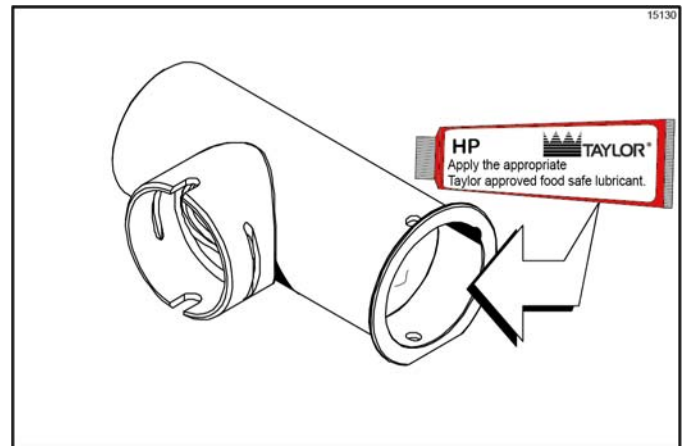

Figure 6-36

4. Insert the piston into the retaining pin end of the pump cylinder. (See Figure 6-37.)

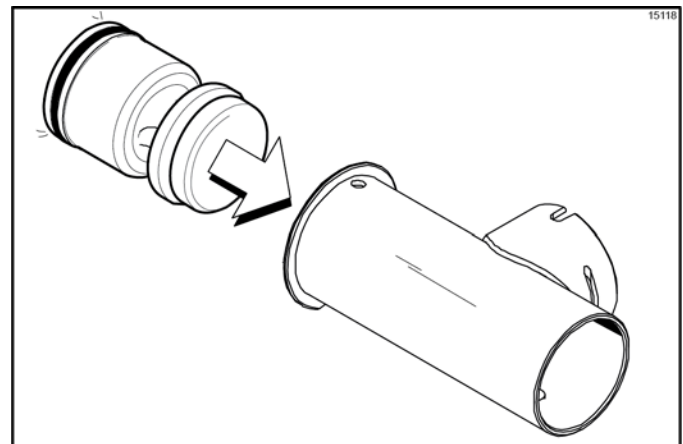

Figure 6-37

5. Assemble the valve cap. Slide the red O-ring into the groove of the valve cap. **Do not** lubricate the O-ring. (See Figure 6-38.)

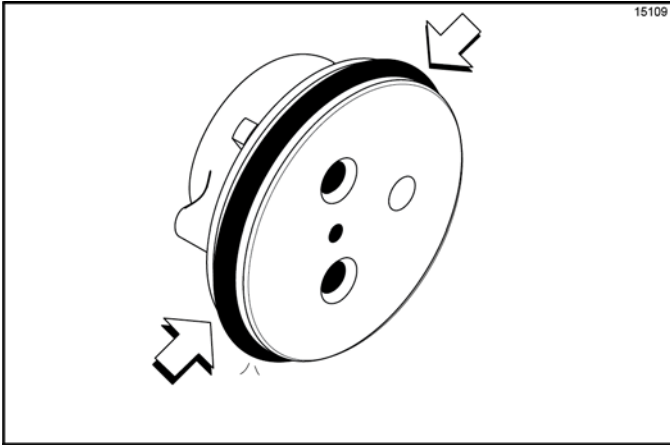

Figure 6-38

6. Slide the pump valve gasket into the holes on the cap. **Do not** lubricate the gasket. (See Figure 6-39.)

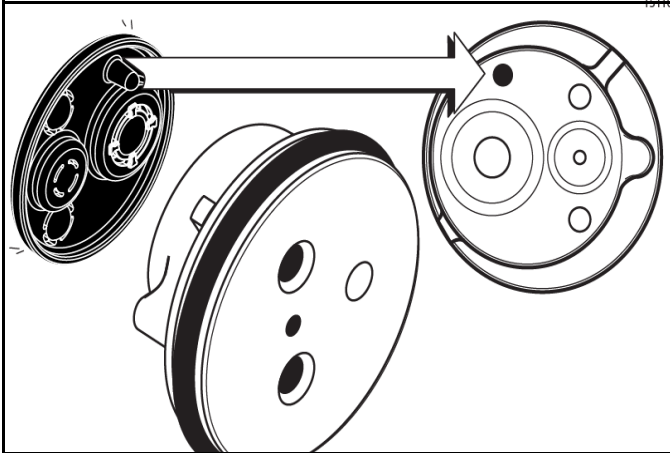

Figure 6-39

7. Insert the valve cap into the hole in the mix inlet adapter. (See Figure 6-40.)

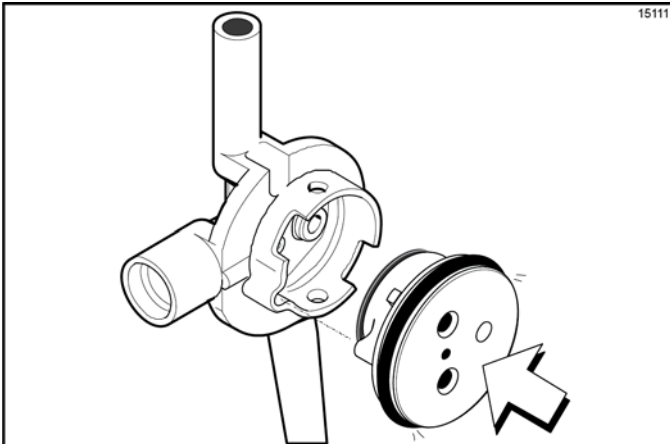

Figure 6-40

8. Insert the mix inlet assembly into the pump cylinder. (See Figure 6-41.)

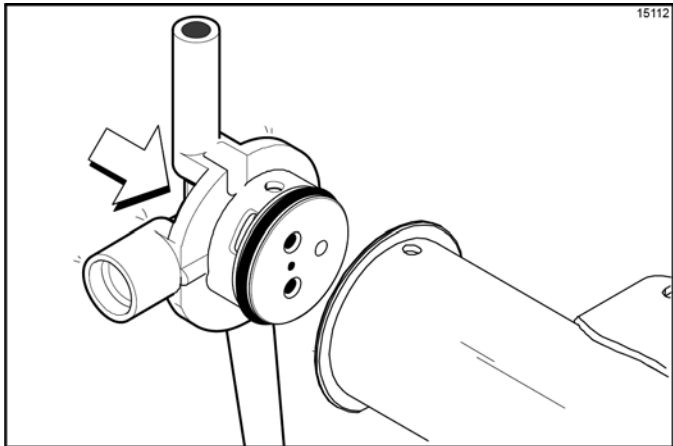

Figure 6-41

Note: The adapter must be positioned into the notch located at the end of the pump cylinder.

9. Secure the pump parts in position by sliding the retaining pin through the cross holes located at one end of the pump cylinder. (See Figure 6-42.)

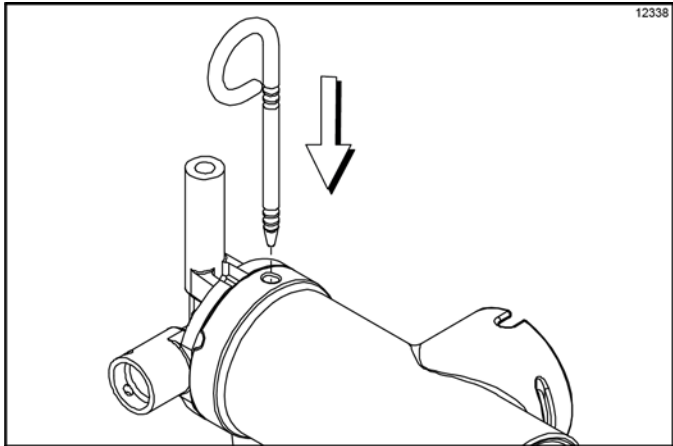

Figure 6-42

Note: The head of the retaining pin should be located at the top of the pump when installed.

OPERATING PROCEDURES

10. Assemble the feed tube assembly. Slide the check ring into the groove of the feed tube.
(See Figure 6-43.)

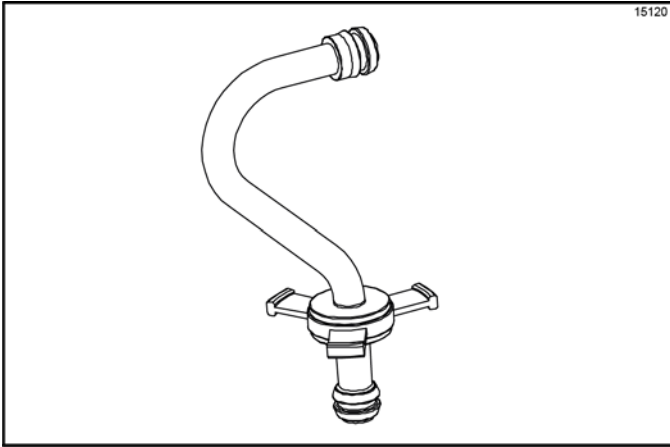

Figure 6-43

11. Install one red O-ring on each end of the mix feed tube, and thoroughly lubricate them.
(See Figure 6-44.)

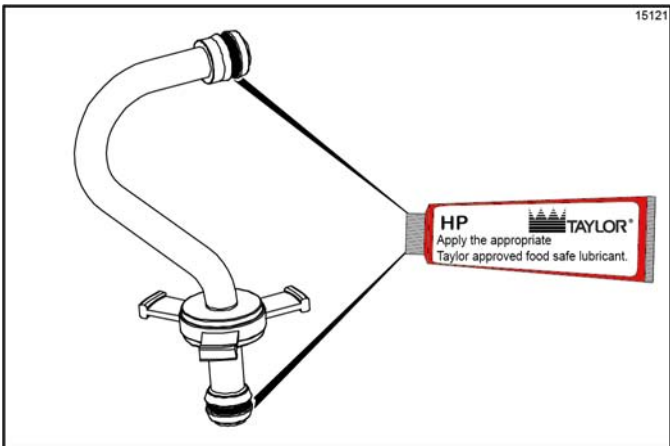

Figure 6-44

12. Lay the pump assembly, pump clip, cotter pin, and agitator in the bottom of the mix hopper for sanitizing.
(See Figure 6-45.)

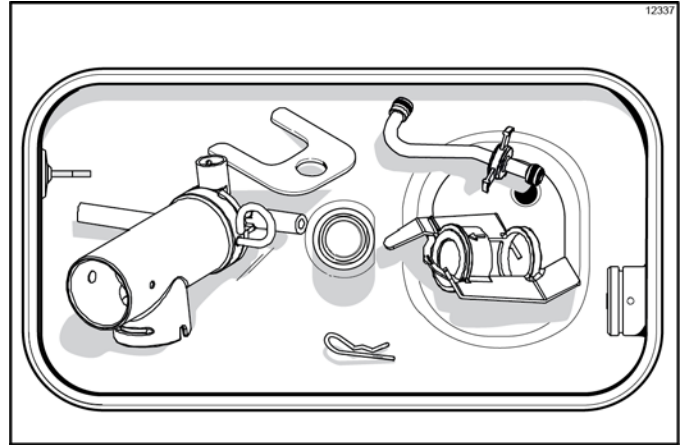

Figure 6-45

13. Slide the large black O-ring and the two smaller black O-rings into the grooves on the driveshaft. Thoroughly lubricate the O-rings and shaft. **Do not** lubricate the hex end of the shaft. (See Figure 6-46.)

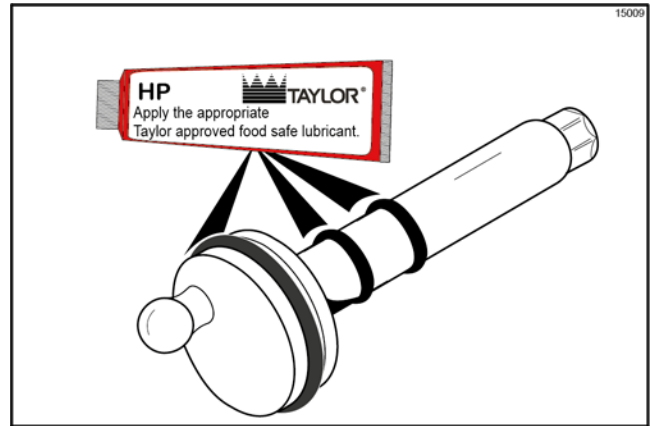

Figure 6-46

14. Install the hex end of the driveshaft into the drive hub at the rear wall of the mix hopper. (See Figure 6-47.)

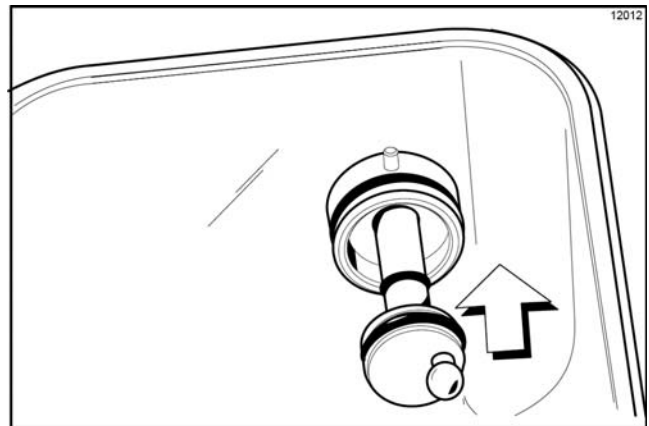

Figure 6-47

Note: For ease in installing the pump, position the ball crank of the driveshaft in the 3 o'clock position.

Sanitizing—Shake Side

1. Prepare a pail of an approved 100 PPM sanitizing solution (examples: 2-1/2 gal. [9.5 L] of Kay-5[®] or 2 gal. [7.6 L] of Stera-Sheen[®]).

Important! Use warm water and follow the manufacturer's specifications.

2. Install syrup hole plugs in the syrup ports in the freezer door. (See Figure 6-48.)

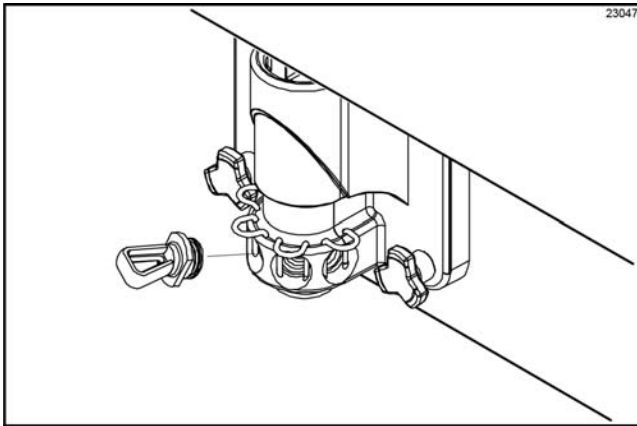

Figure 6-48

3. Pour the sanitizing solution over all parts in the bottom of the mix hopper and allow it to flow into the freezing cylinder.

Note: You have just sanitized the mix hopper and parts; therefore, make sure your hands are clean and sanitized before continuing these instructions.

4. Prepare two more pails of an approved 100 PPM sanitizing solution (examples: Kay-5[®] or Stera-Sheen[®]).

Important! Use warm water and follow the manufacturer's specifications.

5. Install the air/mix pump assembly at the rear of the mix hopper. To position the pump on the drive hub, align the drive slot in the piston with the drive crank of the driveshaft. Secure the pump in place by slipping the pump clip over the collar of the pump, making sure the clip fits into the grooves in the collar. (See Figure 6-49.)

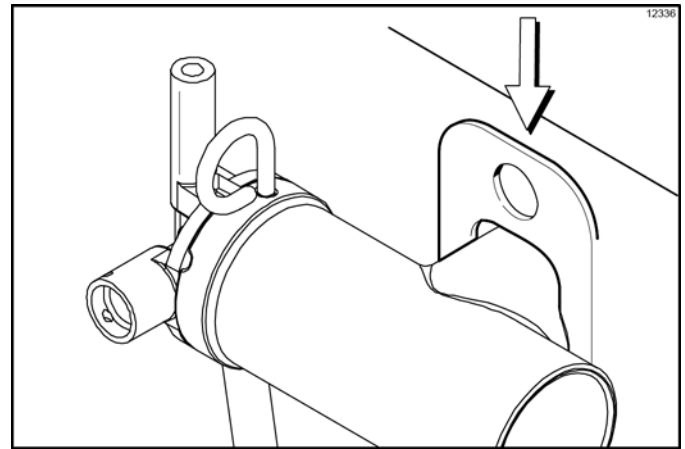



Figure 6-49

CAUTION: Install the pump end of the mix feed tube and secure with the cotter pin. Failure to follow this instruction could result in sanitizer spraying on the operator.

6. Using the white hopper brush, clean the mix-level sensing probes, mix hopper, mix inlet hole, outside of the agitator driveshaft housing, agitator, air/mix pump, pump clip, mix feed tube, and cotter pin.
7. Pour the two pails of sanitizing solution into the mix hopper. The sanitizing solution should be within 1 in. (25 mm) of the top of the hopper.
8. Using the white hopper brush, scrub the exposed sides of the hopper. Wait at least 5 minutes before proceeding with these instructions.
9. Place the power switch in the ON position.
10. Press the Wash key . This will cause the sanitizing solution in the freezing cylinder to come in contact with all areas of the freezing cylinder. (See Figure 6-50.)

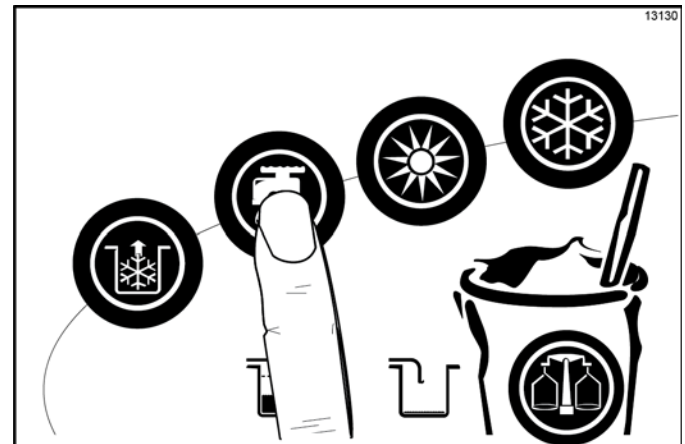





Figure 6-50

OPERATING PROCEDURES

11. With a pail beneath the door spout, open and close the draw valve six times.
12. Press the Pump key  to sanitize the inside of the air/mix pump and the mix feed tube.
13. Open the draw valve and draw off all the remaining sanitizing solution.

Important! The machine must **not** be placed in Auto until all sanitizing solution has been removed from the freezing cylinder and proper priming procedures have been completed. Failure to follow this instruction may result in damage to the freezing cylinder.

14. Press the Wash  and Pump  keys to stop the Wash and Pump modes and to close the draw valve. (See Figure 6-51.)

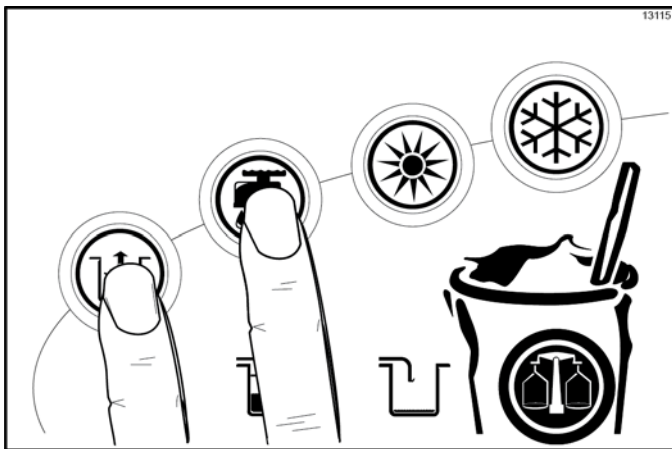

Figure 6-51

Note: Make sure your hands are clean and sanitized before continuing these instructions.

15. Place the agitator on the agitator driveshaft housing. (See Figure 6-52.)

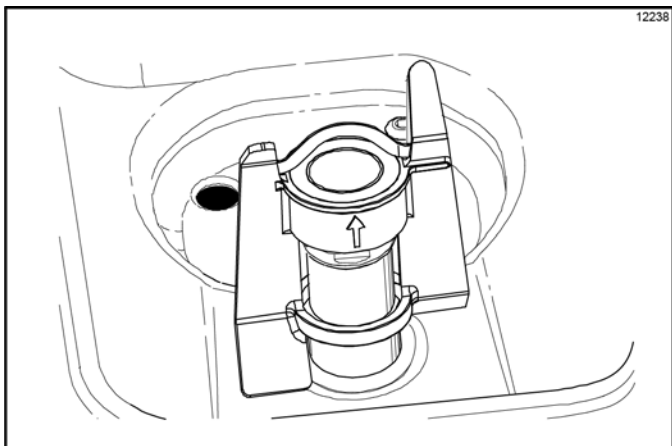

Figure 6-52

Note: If the agitator paddle stops turning during normal operation, with sanitized hands, remove the agitator from the agitator driveshaft housing and brush clean it with sanitizing solution. Install the agitator onto the agitator driveshaft housing.

16. Remove the cotter pin from the pump. Stand the mix feed tube in the corner of the mix hopper. Place the cotter pin in position in the outlet fitting of the pump.

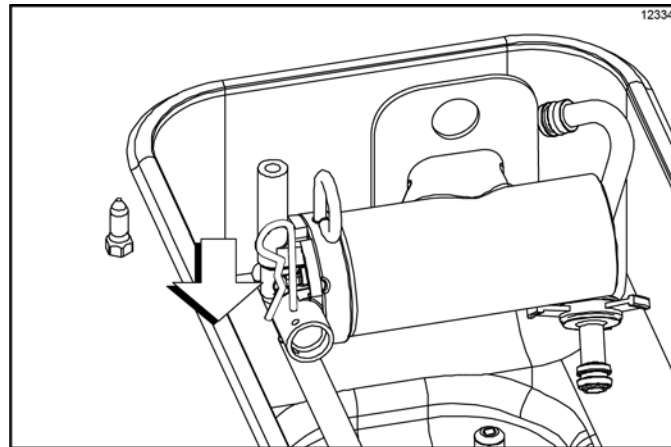

Figure 6-53

17. Remove the restrictor cap and the syrup hole plugs.
18. Return to the freezer with a small amount of sanitizing solution. With a pail below the door spout, dip the door spout brush into the sanitizing solution and brush clean the syrup ports in the freezer door, door spout, bottom of the driven spinner and spinner blade, and syrup line fittings.

Note: To ensure sanitary conditions are maintained, brush clean each item for a total of 60 seconds, repeatedly dipping the brush in sanitizing solution.

19. With the syrup port brush, brush each syrup port hole 10 to 15 times. Dip the brush in sanitizing solution before brushing each port.
20. Fill the squeeze bottle with sanitizing solution. With a pail beneath the door, insert the tube end of the squeeze bottle into the syrup port, and squeeze the bottle firmly. This action will force solution out of the adjacent port and down around the spinner. This procedure should be performed for at least 10 seconds per port.
21. Install the syrup valves and the restrictor cap.

Sanitizing—Soft Serve Side

1. Prepare a pail of an approved 100 PPM sanitizing solution (examples: 2-1/2 gal. [9.5 L] of Kay-5[®] or 2 gal. [7.6 L] of Stera-Sheen[®]).

Important! Use warm water and follow the manufacturer's specifications.

2. Pour the sanitizing solution over all the parts in the bottom of the mix hopper and allow it to flow into the freezing cylinder.

Note: You have just sanitized the mix hopper and parts; therefore, make sure your hands are clean and sanitized before continuing these instructions.

While the solution is flowing into the freezing cylinder, take particular care to brush clean the mix-level sensing probes, mix hopper, mix inlet hole, outside of the agitator housing, agitator, air/mix pump, pump clip, mix feed tube, and cotter pin.

3. Install the pump assembly at the rear of the mix hopper. To position the pump on the drive hub, align the drive hole in the piston with the drive crank of the driveshaft. Secure the pump in place by slipping the pump clip over the collar of the pump, making sure the clip fits into the grooves in the collar. (See Figure 6-54.)

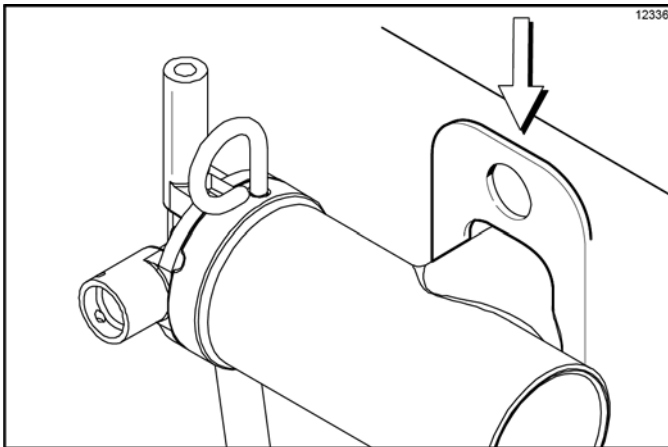



Figure 6-54

CAUTION: Install the pump end of the mix feed tube and secure with the cotter pin. Failure to follow this instruction could result in sanitizer spraying on the operator.



4. Prepare another pail of an approved 100 PPM sanitizing solution (examples: Kay-5[®] or Stera-Sheen[®]).

Important! Use warm water and follow the manufacturer's specifications.

5. Pour the sanitizing solution into the mix hopper.
6. Brush the exposed sides of the hopper. Wait at least 5 minutes before proceeding with these instructions.

7. Press the Wash key . This will cause the sanitizing solution in the freezing cylinder to be agitated.

8. With a pail beneath the door spout, open the draw valve and press the Pump key . Open and close the draw valve six times. Open the draw valve and draw off the sanitizing solution.

9. Press the Wash  and Pump  keys and close the draw valve. (See Figure 6-55.)

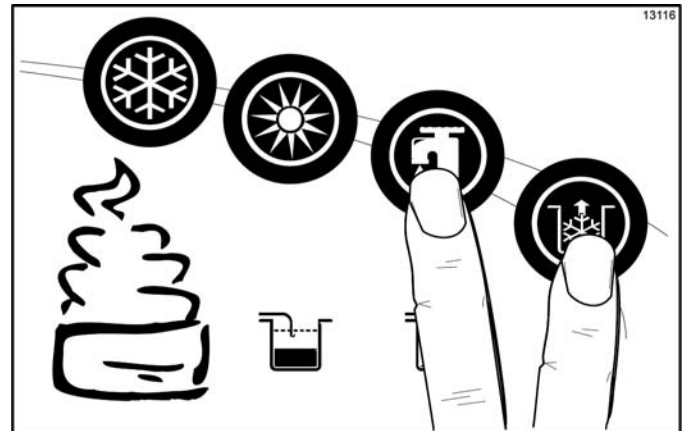

Figure 6-55

Important! The machine must not be placed in Auto until all sanitizing solution has been removed from the freezing cylinder and proper priming procedures have been completed. Failure to follow this instruction may result in damage to the freezing cylinder.

Note: Make sure your hands are clean and sanitized before continuing these instructions.

OPERATING PROCEDURES

- Place the agitator on the agitator driveshaft housing.
(See Figure 6-56.)

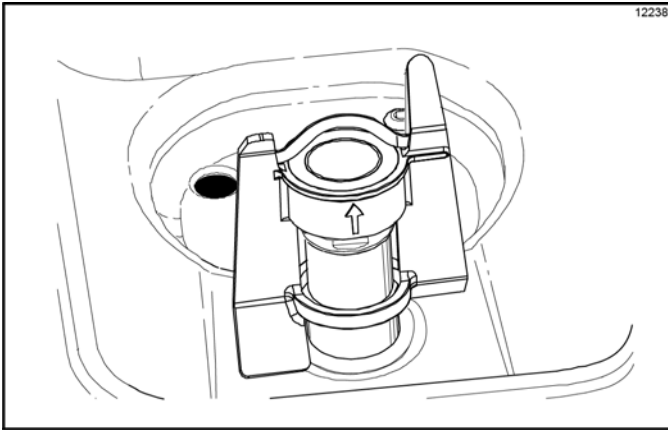

Figure 6-56

Note: If the agitator stops turning during normal operation, with sanitized hands remove the agitator from the agitator driveshaft housing and brush clean it with sanitizing solution. Install the agitator onto the agitator driveshaft housing.

- Remove the cotter pin from the pump. Stand the mix feed tube in the corner of the mix hopper. Place the cotter pin in position in the outlet fitting of the pump.
(See Figure 6-57.)

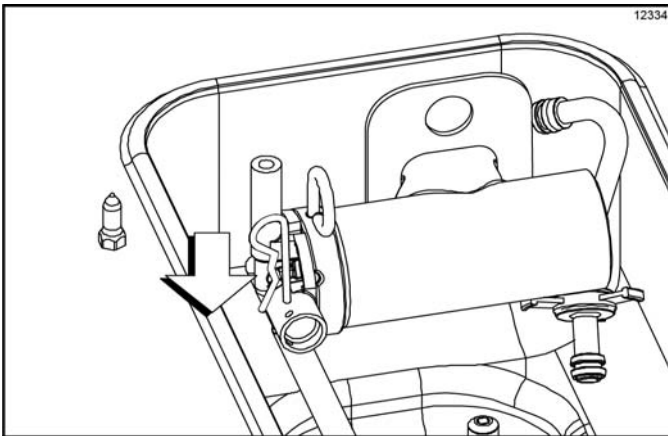



Figure 6-57

Note: You have just sanitized all food contact surfaces of the freezer.

Priming—Shake Side

Note: Use only fresh mix when priming the freezer.

- With a pail beneath the door spout, press any Flavor

Selection key  to open the draw valve. Pour 2-1/2 gal. (9.5 L) of fresh mix into the mix hopper and allow it to flow into the freezing cylinder. This will

force out any remaining sanitizing solution. When full-strength mix is flowing from the door spout, press

any Flavor Selection key  to close the draw valve.

Note: Failure to remove all sanitizing solution may result in damage to the freezing cylinder.

- When the mix stops bubbling down into the freezing cylinder, remove the cotter pin from the outlet fitting of the mix pump. Insert the outlet end of the mix feed tube into the mix inlet hole in the mix hopper. Place the inlet end of the mix feed tube into the outlet fitting of the mix pump. Secure with the cotter pin. (See Figure 6-58.)

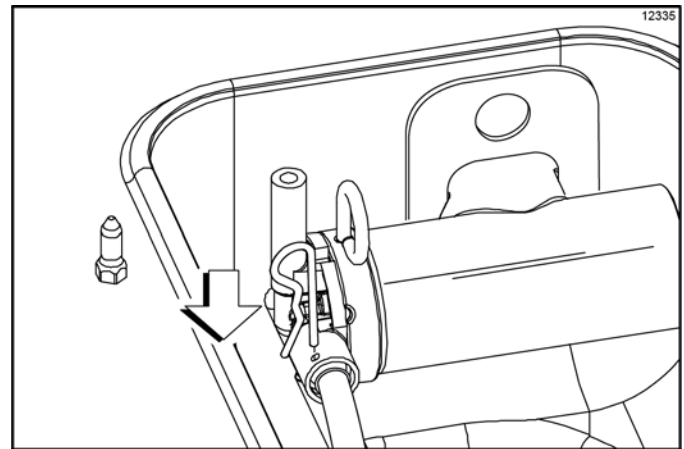

Figure 6-58

- Install the shake cup holder. (See Figure 6-59)

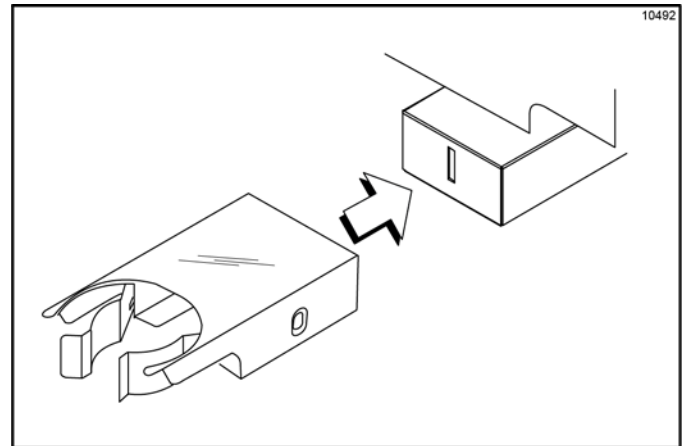



Figure 6-59

- Select the Auto key .
- Fill the hopper with fresh mix and place the mix hopper cover in position.

Priming—Soft Serve Side

Note: Use only fresh mix when priming the freezer.

1. With a pail beneath the door spout, open the draw valve. Pour 2-1/2 gal. (9.5 L) of fresh mix into the mix hopper and allow it to flow into the freezing cylinder. This will force out any remaining sanitizing solution. When full-strength mix is flowing from the door spout, close the draw valve.

Important! Failure to remove all sanitizing solution may result in damage to the freezing cylinder.

2. When the mix stops bubbling down into the freezing cylinder, remove the cotter pin from the outlet fitting of the mix pump. Insert the outlet end of the mix feed tube into the mix inlet hole in the mix hopper. Place the inlet end of the mix feed tube into the outlet fitting of the mix pump. Secure with the cotter pin.

3. Select the Auto key .

Note: This procedure should be done 15 minutes before product is expected to be served.

4. Fill the hopper with **fresh** mix and place the mix hopper cover in position.

Daily Closing Procedures

Note: This procedure must be done at the close of business.

Shake Side

Important! Fill the mix hopper with mix up to the fill level indicator on the agitator paddle. (See Figure 6-60.)

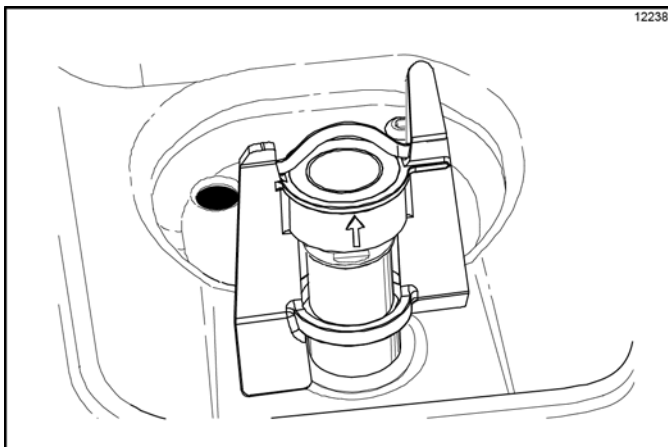





Figure 6-60

Both sides of the freezer must be in the Auto mode (Auto

key  is illuminated) or in the Standby mode (Standby

keys  and  are illuminated) before the heat cycle may be started.

Note: If the BRUSH CLEAN COUNTER display has counted down to 1 day, **do not add mix**. The machine must be disassembled and brush cleaned within 24 hours.

1. Remove the hopper cover, shake cup holder, splash shield, and drip pans.

Note: Make sure your hands are clean and sanitized before performing these next steps.

Note: Select the Calibration key  to stop agitator movement for 10 seconds. Select the

Calibration key  again to exit the Calibration mode. The agitator will automatically restart after 10 seconds.

2. Remove the agitator from the mix hopper and the restrictor cap from the shake freezer door spout.
3. Take the agitator, hopper cover, shake cup holder, drip pans, front drip tray, splash shield, and restrictor cap to the sink for further cleaning and sanitizing. Take the syrup hole plugs, spout cap, and spout cap O-ring to the sink for further cleaning and sanitizing.
4. Rinse these parts in cool, clean water.
5. Prepare a small amount of an approved 100 PPM cleaning solution (examples: Kay-5[®] or Stera-Sheen[®]).

Important! Use warm water and follow the manufacturer's specifications.

6. Brush clean these parts.
7. Place the restrictor cap, front drip tray, shake cup holder, and splash shield on a clean, dry surface to air dry overnight or until the heating cycle is complete.
8. Prepare a small amount of an approved 100 PPM sanitizing solution (examples: Kay-5[®] or Stera-Sheen[®]).

Important! Use warm water and follow the manufacturer's specifications.

9. Sanitize the syrup hole plugs, spout cap, spout cap O-ring, drip pans, agitator, and hopper cover.

OPERATING PROCEDURES

10. Install the agitator onto the agitator driveshaft housing. Replace the hopper cover. (See Figure 6-61.)

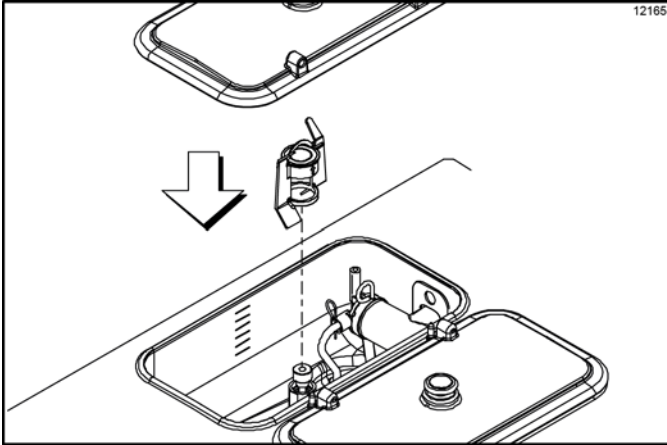

Figure 6-61

Important! If you do not install the agitator correctly, the machine will fail the heat cycle and will lock out in the morning.

11. Remove the syrup lines from the freezer door. (See Figure 6-62.)

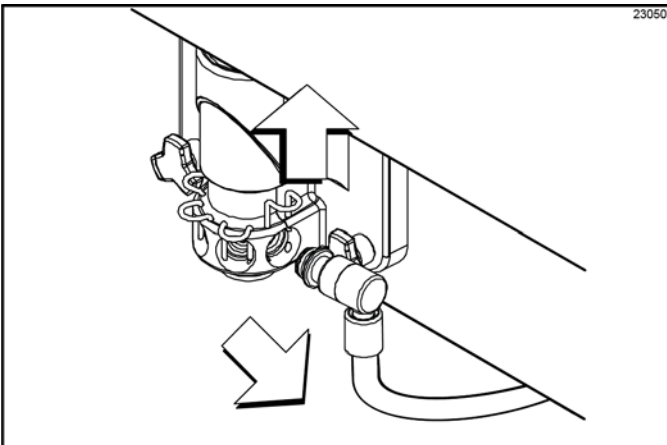

Figure 6-62

12. Return to the freezer with a small amount of cleaning solution. With a pail below the door spout, dip the door spout brush into the cleaning solution and brush clean the syrup ports in the freezer door, door spout, and bottom of the driven spinner, spinner blade, and syrup line fittings. (See Figure 6-63.)

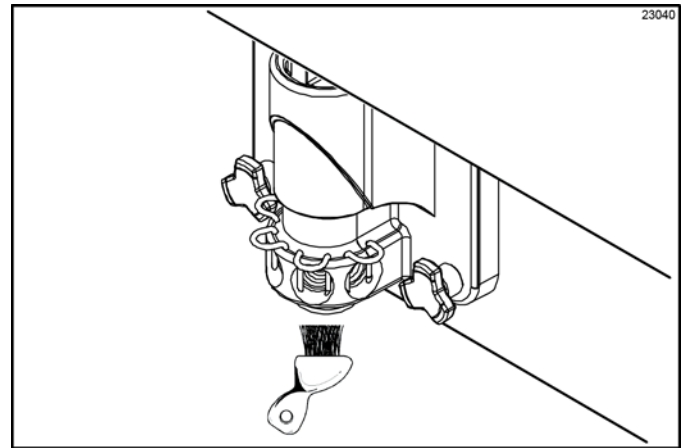

Figure 6-63

Note: To ensure sanitary conditions are maintained, brush each item for a total of 60 seconds, repeatedly dipping the brush in the cleaning solution.

13. With the syrup port brush, brush each syrup port hole 10 to 15 times. Dip the brush in the cleaning solution before brushing each port. (See Figure 6-64.)

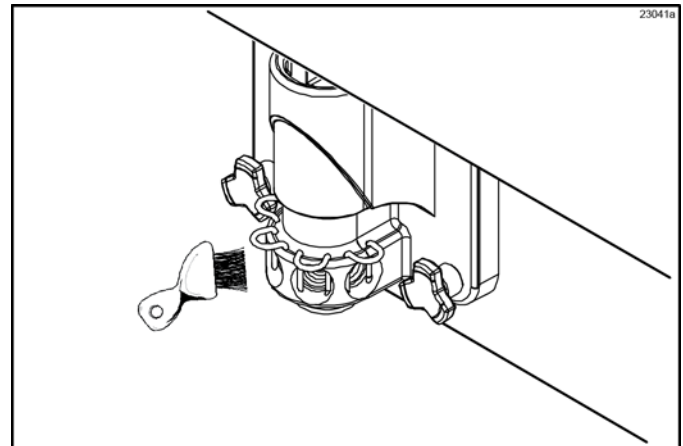

Figure 6-64

14. With sanitized hands, remove the syrup valve retainers. Brush clean the retainers and retainer holes. Replace the syrup valve retainers.

15. Fill the squeeze bottle with cleaning solution. With a pail beneath the door, insert the tube end of the squeeze bottle into the syrup ports, and squeeze the bottle firmly. This action will force solution out of the adjacent port and down around the spinner. This procedure should be performed for at least 10 seconds per port. (See Figure 6-65.)

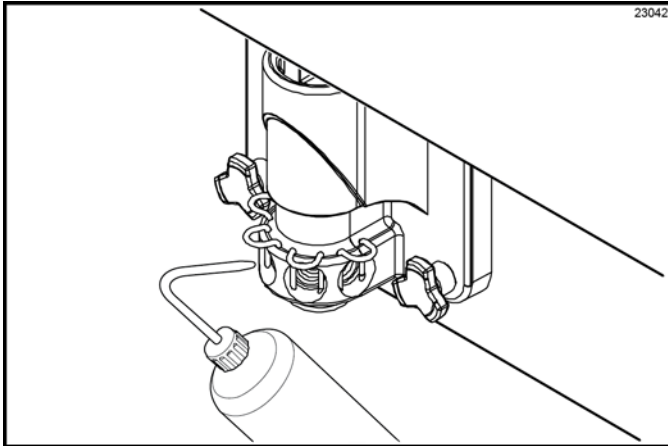

Figure 6-65

16. Place the spout cap O-ring in the spout cap. Fill the spout cap with sanitizing solution. Install the spout cap over the end of the door spout. (See Figure 6-66.)

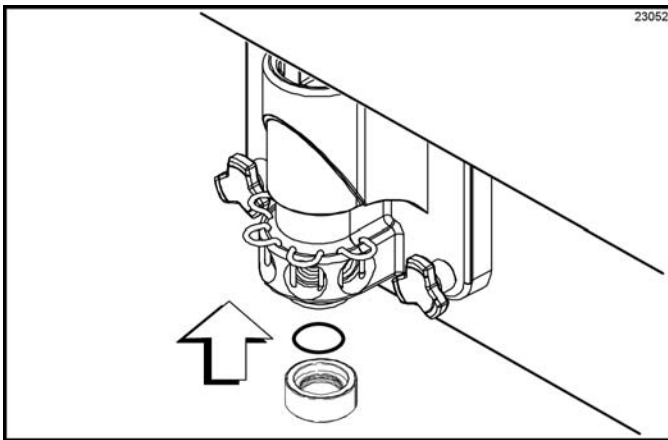

Figure 6-66

17. Raise each retainer pin. Install the syrup hole plugs in the syrup ports in the freezer door. Lower the retainer pins to secure the hole plugs in the door. (See Figure 6-67.)

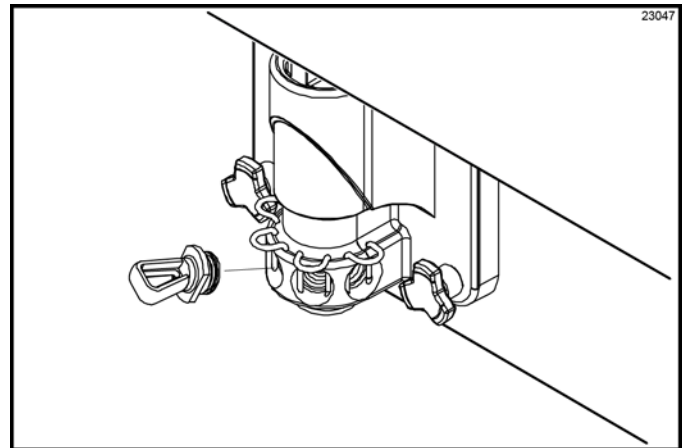

Figure 6-67

18. Fill the squeeze bottle with sanitizing solution. Hold the bottle over a pail. Squeeze the bottle and thoroughly rinse the slot of each syrup nose fitting.

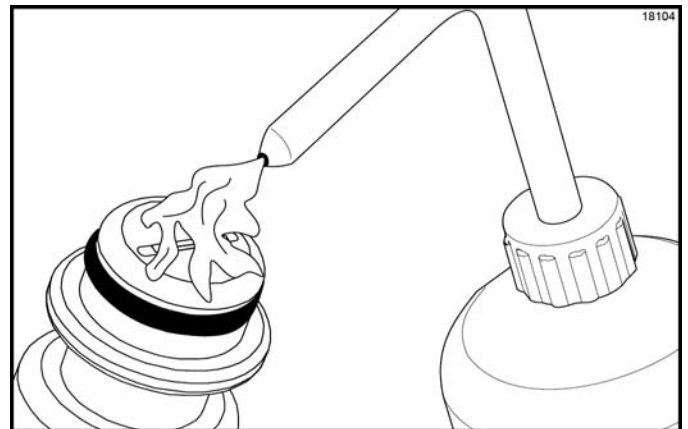

Figure 6-68

19. Wipe the outside of each syrup nose fitting with a sanitized towel.
20. Using a clean, sanitized towel, wipe down the freezer door, front panel, the area around the bottom of the freezer door, and any other areas that demonstrate a buildup of either moisture or food substance.

Soft Serve Side

Note: This procedure must be done at the close of business.

Important! Fill the mix hopper with mix up to the fill level indicator on the agitator paddle. (See Figure 6-69.)

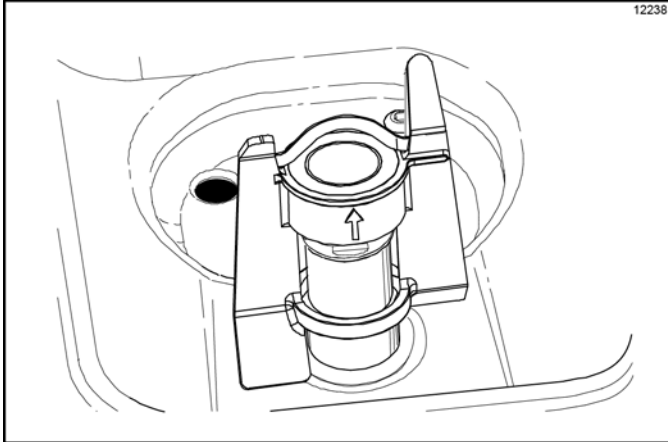





Figure 6-69

Note: If the BRUSH CLEAN COUNTER display has counted down to 1 day, do not add mix. The machine must be disassembled and brush cleaned within 24 hours.

Both sides of the freezer must be in the Auto mode (Auto

6 key  is illuminated) or Standby mode (Standby

keys  and  are illuminated) before the heat treatment cycle may be started.

1. Place the topping heater switches in the OFF position

by pressing the Topping Heater keys . The keys will not be illuminated when the heaters are off. (See Figure 6-70.)

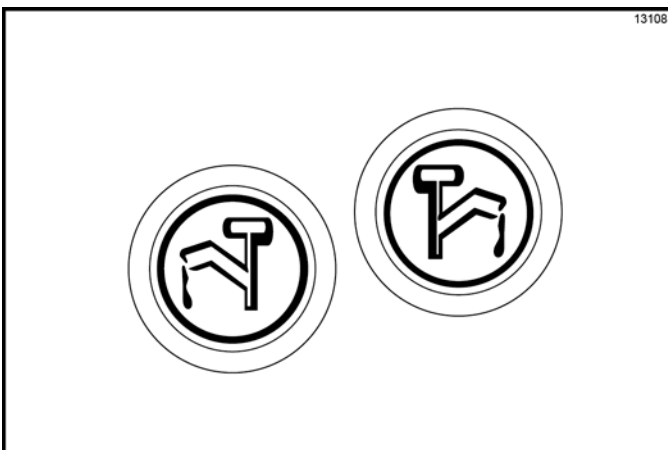



Figure 6-70

2. Remove the hopper cover.

Important! Make sure your hands are clean and sanitized before performing these next steps.

Note: Select the Calibration key  to stop agitator movement for 10 seconds. Select the

Calibration key  again to exit the Calibration mode. The agitator will automatically restart after 10 seconds.

3. Remove the agitator from the mix hopper.

4. Take the agitator and hopper cover to the sink for further cleaning and sanitizing.

5. Rinse these parts in cool, clean water.

6. Prepare a small amount of an approved 100 PPM sanitizing solution (examples: Kay-5[®] or Stera-Sheen[®]).

Important! Use warm water and follow the manufacturer's specifications.

Brush-clean the parts.

7. Prepare a small amount of an approved 100 PPM sanitizing solution (examples: Kay-5[®] or Stera-Sheen[®]).

Important! Use warm water and follow the manufacturer's specifications.

Sanitize the agitator and hopper cover.

8. Install the agitator onto the agitator driveshaft housing. Replace the hopper cover.

Important! If the agitator is not installed correctly, the machine will fail the heat treatment cycle and will lock out in the morning.

9. Return to the freezer with a small amount of cleaning solution. Dip the door spout brush into the cleaning solution and brush clean the door spout and bottom of the draw valve.

Note: To ensure sanitary conditions are maintained, brush each item for a total of 60 seconds, repeatedly dipping the brush in cleaning solution. (See Figure 6-71.)

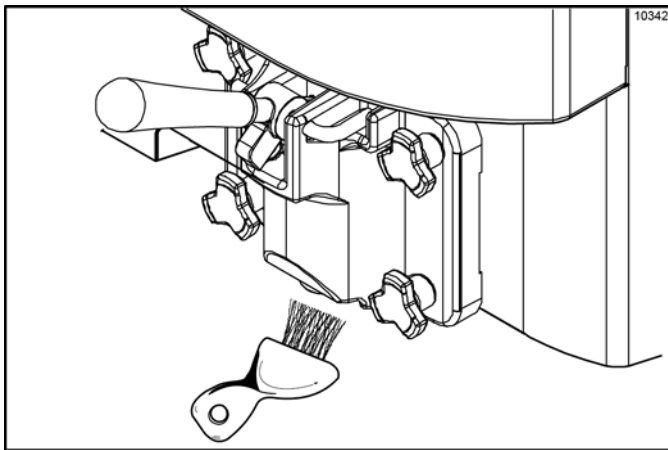

Figure 6-71

10. Remove, clean, and reinstall the long drip pan through the front panel. (See Figure 6-72.)

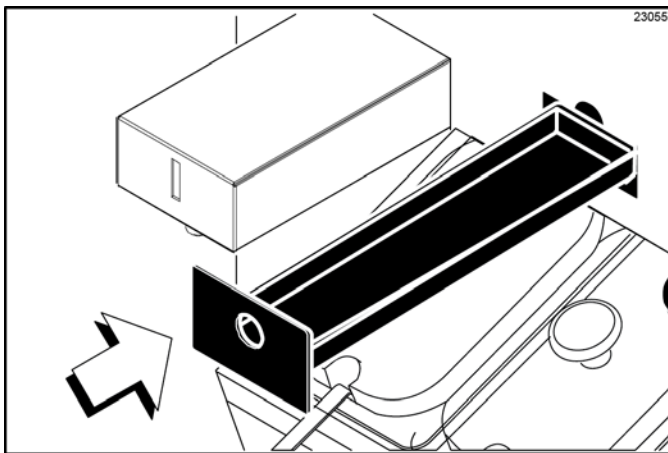

Figure 6-72

11. Remove, clean, and reinstall the two short drip pans in the rear panel.
12. Remove, clean, and reinstall the two notched drip pans in the left and right side panels. (See Figure 6-73.)

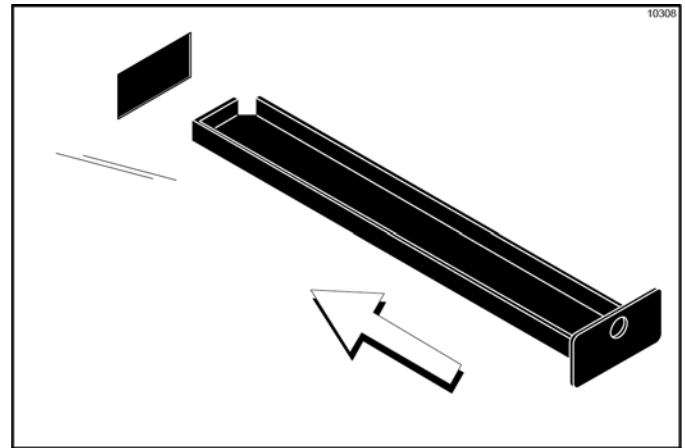



Figure 6-73

13. Using a clean, sanitized towel, wipe down the freezer door, front panel, the area around the bottom of the freezer door, and any other areas that demonstrate a buildup of either moisture or food substance.

The heat treatment cycle will start at the AUTO HEAT TIME setting in the Manager's Menu (See "AUTO HEAT TIME" on page 5-11.)

There are three phases of the heat cycle: heating, holding, and cooling. Each phase has a time limit. If any one of the three phases fail to reach the proper temperatures within the time limit, the cycle will automatically abort and return to the Standby mode.

A failure message will appear on the vacuum fluorescent display (VFD) to inform the operator that the machine did not successfully complete the heat treatment cycle. The product may not be safe to serve. The freezer will be locked out (soft lock) of the Auto mode. The operator will



be given the option of selecting the Heat Cycle key  which will begin a new heat treatment cycle, or pressing

the Wash key  which will place the side(s) into the OFF mode to allow a brush-clean of the machine.

Note: Once the heat treatment cycle has started, it cannot be interrupted. The heat treatment cycle will take a maximum of 4 hours to complete with full hoppers.

Important! Do not attempt to draw product or disassemble the machine during the heat treatment cycle. The product is hot and under extreme pressure.

When the heat treatment cycle is complete, the control will return to the Standby mode. The Standby keys

 and  will be illuminated.

Daily Opening Procedures

Before performing the opening procedures, check the display panel for any error messages. Normally the display is blank, unless an operational fault has occurred. If a fault has been detected, investigate the cause and follow the instructions on the display before proceeding with the opening procedures. See Heat Treatment Cycle Failure Messages on page 5-5 and Faults Occurring Entering a Heat Treatment Cycle on page 5-14.

Setup

Note: Make sure your hands are clean and sanitized before performing these next steps.

1. With the drain plugs closed, check the water level in the two heated topping wells. Fill the wells with water to the indicating mark on the bottom of the well.
2. Place the topping heaters in the ON position by

pressing the Topping Heater keys .

CAUTION: As soon as the heaters are turned on, the topping wells will begin heating. This heating process will take approximately 2-1/2 hours to reach temperature. The water level in the wells should be checked daily.

3. Prepare a pail of an approved 100 PPM sanitizing solution (examples: Kay-5® or Stera-Sheen®).

Important! Use warm water and follow the manufacturer's specifications.

Sanitize the topping pumps by placing the entire pump assembly in the pail of sanitizing solution. Pump the solution through to thoroughly sanitize the pump.

4. Fill the topping containers with topping. Place the caramel and fudge topping containers in the heated wells. Place the remaining two topping containers in the unheated wells. Cover the containers.
5. Sanitize the two topping ladles and place them in the cold topping containers.
6. Fill the cup dispensers, cup lid holder, and cone dispenser.

7. To fill the cone dispenser, slide the drawer up and pull out. Push the spring guide all the way back to its locking position. Place the cones in the drawer and release the spring guide.

Shake Side

1. When the heating cycle is complete, the Heat Cycle keys  will no longer be illuminated and the machine will automatically enter the Standby mode. Prepare a small amount of an approved

100 PPM sanitizing solution (examples: Kay-5® or Stera-Sheen®).

Important! Use warm water and follow the manufacturer's specifications.

2. Remove the syrup hole plugs, the syrup valve retainers, and the valve cap from the freezer door. Sanitize the restrictor cap, syrup hole plugs, syrup valve retainers, spout cap, and O-ring, shake cup holder, front drip tray, and splash shield in this solution.
3. Return to the freezer with a small amount of sanitizing solution. With a pail below the door spout, dip the door spout brush into the sanitizing solution. Brush clean the door spout, the bottom of the driven spinner, spinner blade, and the syrup line fittings. (See Figure 6-74.)

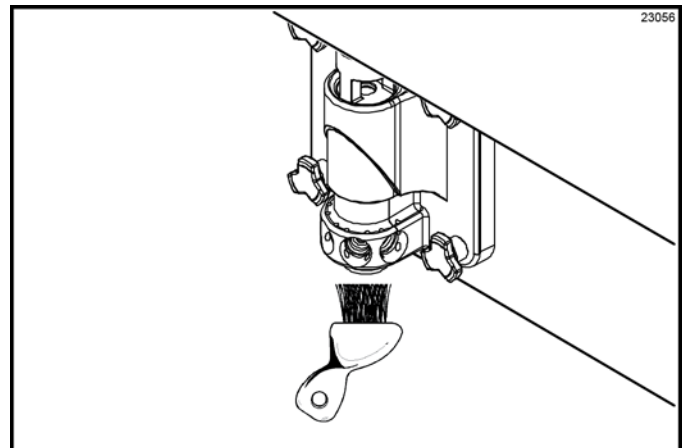

Figure 6-74

Note: To ensure sanitary conditions are maintained, brush clean each item for a total of 60 seconds, repeatedly dipping the brush in sanitizing solution.

- With the syrup port brush, brush each syrup port hole 10 to 15 times. Dip the brush in sanitizing solution before brushing each port. (See Figure 6-75.)

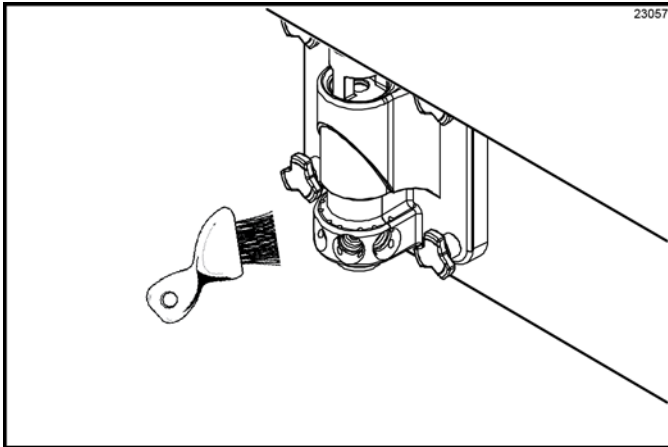

Figure 6-75

- Fill the squeeze bottle with sanitizing solution. With a pail beneath the door, insert the tube end of the squeeze bottle into the syrup port, and squeeze the bottle firmly. This action will force solution out of the adjacent port and down around the spinner. This procedure should be performed for at least 10 seconds per port. (See Figure 6-76.)

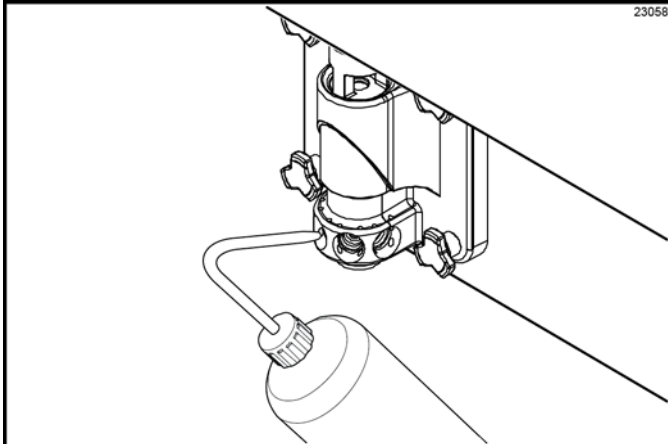

Figure 6-76

- Reinstall the syrup valve retainers.
- Install the restrictor cap on the freezer door spout. (See Figure 6-77.)

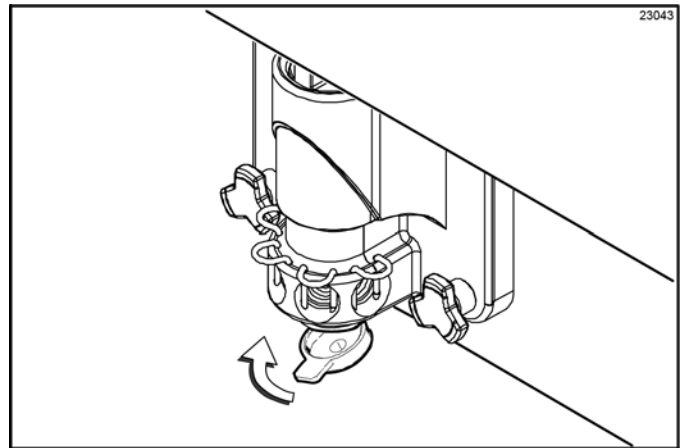

Figure 6-77

- With the pail still beneath the door, remove the syrup nose fitting from the syrup line fitting by turning it counterclockwise. Hold the syrup fittings in an up position to minimize syrup loss. (See Figure 6-78.)

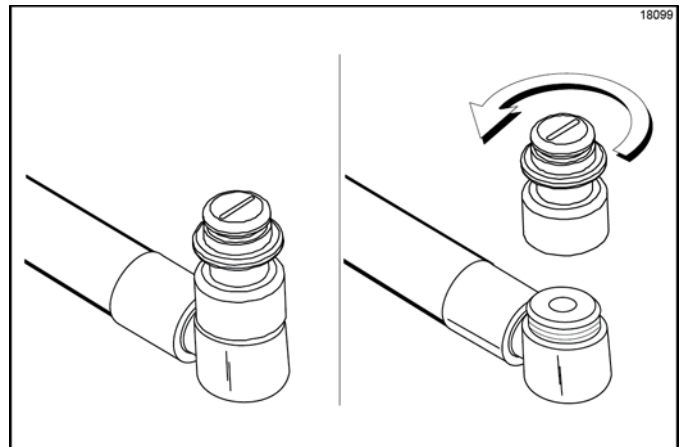

Figure 6-78

- Remove the duckbill valve and the O-ring from the syrup nose fitting.

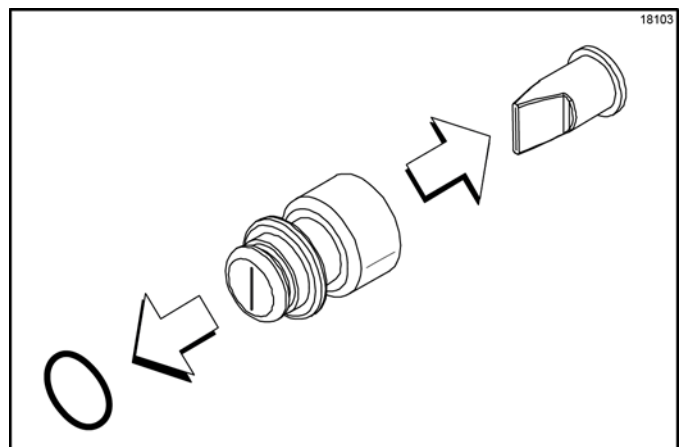

Figure 6-79

OPERATING PROCEDURES

10. Using the white end of the double-ended brush, scrub the inside of the syrup nose fitting to remove any residual particles.
11. Using a shake cup filled with an approved 100 PPM sanitizing solution, rinse the syrup nose fitting thoroughly.
12. Using a clean, sanitized towel, gently wipe any syrup from the duckbill valve.
13. Using a shake cup filled with sanitizing solution, thoroughly rinse the duckbill valve.
14. Install the duckbill valve into the syrup nose fitting with the flat end aligned with the open slot in the syrup nose fitting.

Note: Replace the duckbill valve if it is damaged or extends past the syrup nose fitting slot. (See Figure 6-80.)

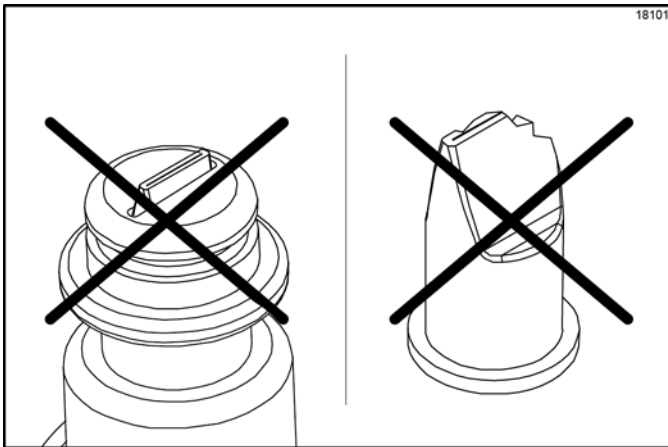

Figure 6-80

15. Install the syrup nose fitting onto the syrup line fitting. Tighten by hand until secured.

Note: The duckbill valve must be wet when the syrup nose fitting is assembled onto the syrup line fitting. The sanitized water will lubricate the bottom flat surface and prevent the duckbill from twisting when the the syrup nose fitting is tightened.

16. Inspect the duckbill valve for proper installation inside the syrup nose fitting. The tip of the duckbill valve must be flat to seal the syrup line. (See Figure 6-81.)

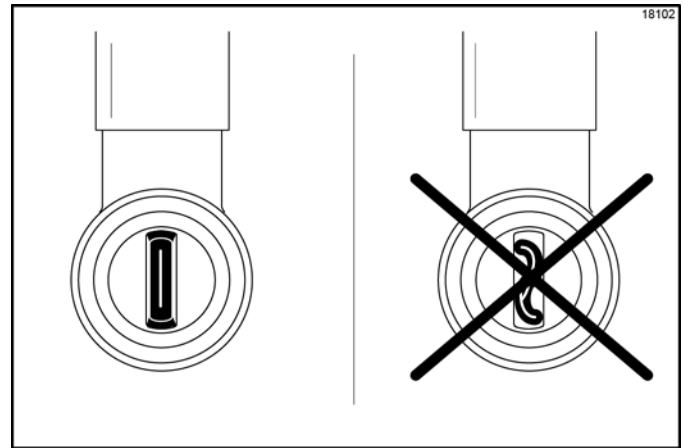

Figure 6-81

If the tip is not flat, remove the syrup nose fitting and remove/reinstall the duckbill valve. Using a shake cup filled with sanitizing solution, rinse the syrup nose fitting to wet the bottom of the duckbill valve. Reinstall the syrup nose fitting onto the syrup line fitting. If the tip will not remain flat when the syrup fitting is assembled, replace the duckbill valve.

17. Install the O-ring on the syrup nose fitting.
18. Repeat step 8 through step 17 for all syrup flavors.
19. Each syrup flavor must be primed to purge the air out of the syrup lines. To prime each syrup line, hold the syrup line up over an empty cup. (See Figure 6-82.)

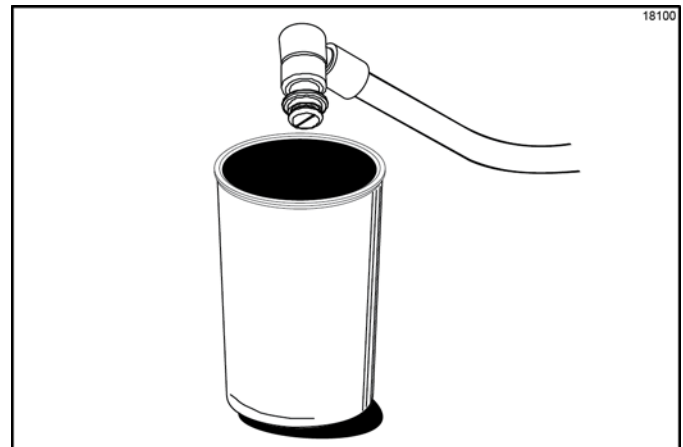



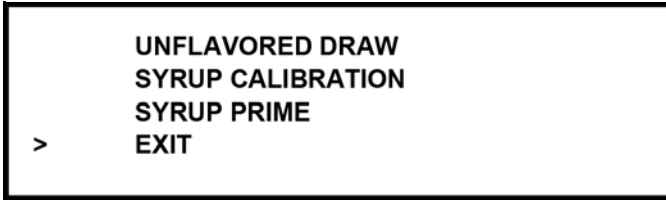

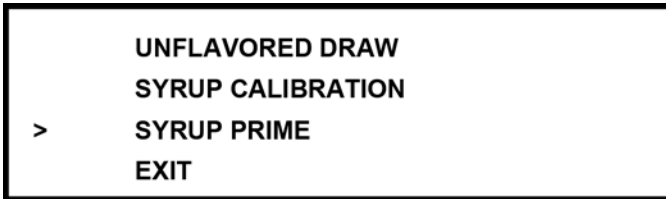

Figure 6-82

20. Press the Calibration key  to display the menu options. The Calibration key , the Auto key  on the shake side, and the Flavor Selection  key will be illuminated. The screen will display the calibration menu options.



21. Press the Auto key  or the Flavor Selection key  to scroll the cursor to SYRUP PRIME.



22. Press the Calibration key  to enter the SYRUP PRIME mode.

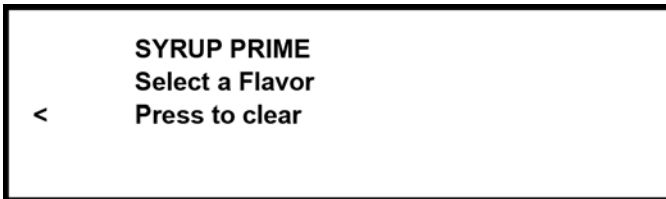

23. Press the corresponding Flavor Selection key . The Flavor key should be illuminated, and the syrup pump for the selected flavor will start running at the maximum speed. (See Figure 6-83.)

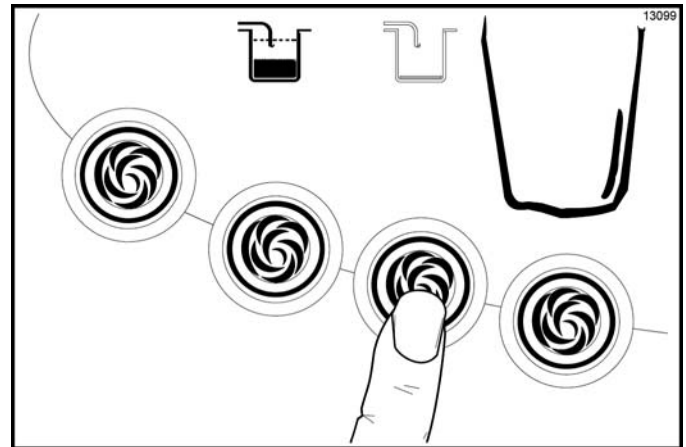



Figure 6-83

24. When a steady stream of syrup is flowing from the syrup valve and all air has been purged from the syrup line, press any Flavor Selection key  to stop the pump.

25. Repeat step 23 and step 24 to prime the rest of the syrup lines. After priming is complete, exit the SYRUP PRIME mode by pressing the Calibration key



26. Using the squeeze bottle filled with sanitizing solution, sanitize the syrup valve nose fittings.

27. Lubricate the O-ring. Raise the syrup valve retainer. Install the syrup valve. Push the syrup valve retainer down to hold the valve in place. Repeat this procedure for each syrup valve. (See Figure 6-84.)

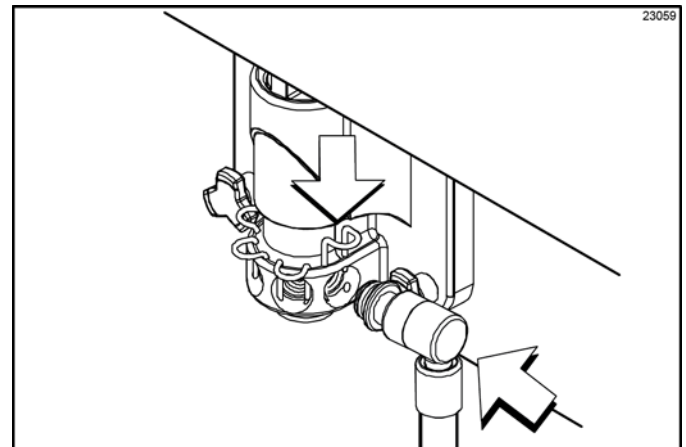

Figure 6-84

OPERATING PROCEDURES

Note: Do not install an empty syrup line in the freezer door. Insert a syrup port plug in the door whenever a syrup line is not in use. This will prevent an accumulation of mix inside the valve fitting and the syrup line.

- Using a clean, sanitized towel, wipe down the freezer door, front panel, the area around the bottom of the freezer door, and any other areas that demonstrate a buildup of either moisture or food substance.
- Install the shake cup holder, front drip tray, and splash shield.
- When ready to resume normal operation, press the

Auto key . (See Figure 6-85.) The control has a feature in the Manager's Menu to enable or disable the AUTO START feature. When AUTO START is enabled, the machine will automatically exit the Standby mode and start both sides in the Auto mode at a designated time each day.



Figure 6-85

Note: Placing the machine in Auto mode should be performed approximately 15 minutes prior to serving product.

Soft Serve Side

- Prepare a small amount of an approved 100 PPM sanitizing solution.
Important! Use warm water and follow the manufacturer's specifications.
- Return to the freezer with a small amount of sanitizing solution. Dip the door spout brush into the sanitizing solution and brush clean the door spout and bottom of the draw valve. (See Figure 6-86.)

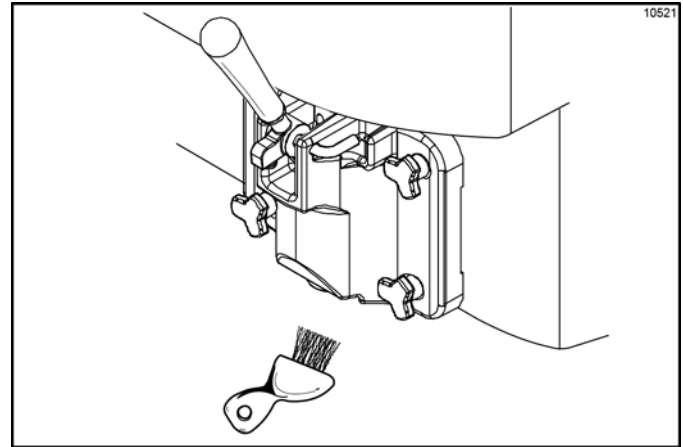



Figure 6-86

Note: To ensure sanitary conditions are maintained, brush clean each item for a total of 60 seconds, repeatedly dipping the brush in sanitizing solution.

- Using a clean, sanitized towel, wipe down the freezer door, front panel, the area around the bottom of the freezer door, and any other areas that demonstrate a buildup of either moisture or food substance.
- When ready to resume normal operation, press the

Auto key . The control has a feature in the Manager's Menu to enable or disable the AUTO START feature. When AUTO START is enabled, the machine will automatically exit the Standby mode and start both sides in the Auto mode at a designated time each day. (See Figure 6-87.)

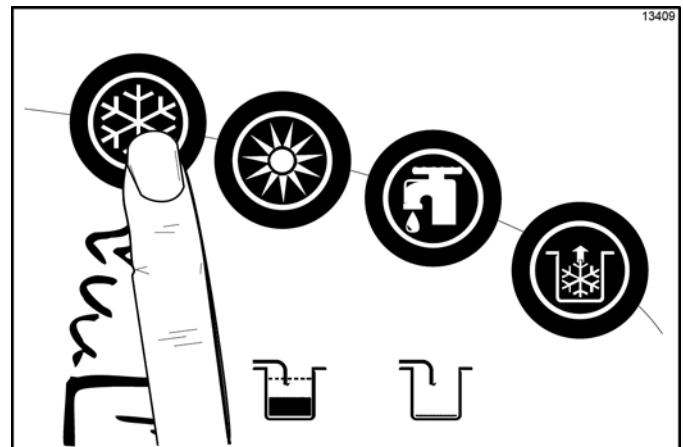

Figure 6-87

Note: This procedure should be performed 15 minutes prior to serving product.

Syrup System





Syrup Calibration

The syrup flow should be calibrated weekly when the syrup system is cleaned. It is vital that the correct amount of syrup be incorporated into the frozen mix to obtain a quality shake.

To determine the rate of syrup flow, you will need a calibration cup indicating fluid ounces. The proper rate of syrup flow is 1 fl. oz. (30 mL) of syrup in 5 seconds. For thick viscosity shake syrups, the proper syrup flow rate is 1 fl. oz. +/- 1/8 fl. oz. (30 mL +/- 4 mL) in 7 seconds. Once this rate is set, the correct amount of syrup will be blended with the shake base regardless of the size of shake served. Please note that syrup calibration is critical when changing the promotional 4th flavor syrup.

Calibration Procedure

Syrup lines must be properly primed with syrup to eliminate air in the line before the calibration procedure is performed. (See "Syrup Priming Procedure" on page 6-26.)

1. Press the Calibration key  to display the menu options. The Calibration key , the Auto key  on the shake side, and the Flavor Selection key  will be illuminated. (See Figure 6-88.)

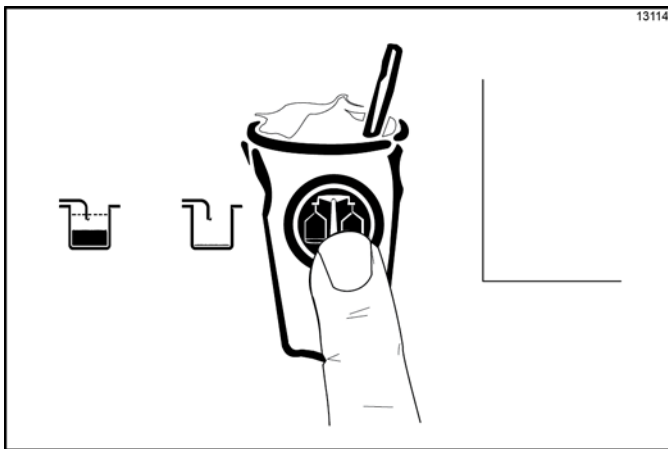
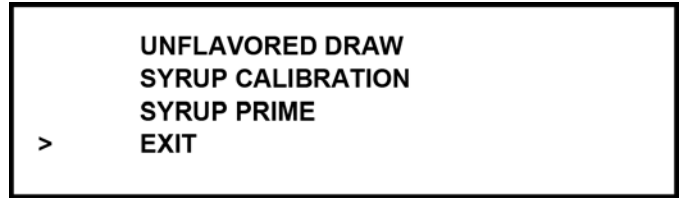





Figure 6-88

The screen will display the calibration menu options:



Note: When the CALIBRATION screen is displayed, the Flavor Selection keys  will not raise the draw valve to dispense shake product.

2. Press the Auto key  or the Flavor Selection key  to scroll the cursor to SYRUP CALIBRATION.

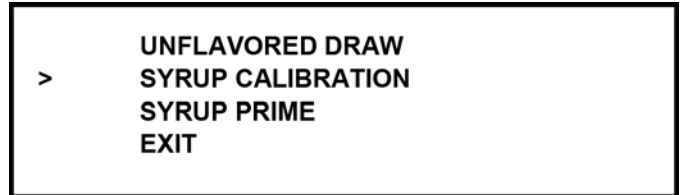

3. Press the CALIBRATION key  to enter the syrup calibration mode.

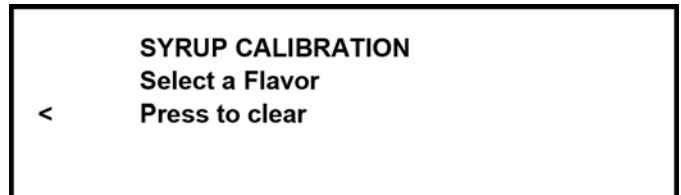

4. Disconnect the syrup valve from the freezer door. Raise the syrup valve retainer and pull the valve straight out. (See Figure 6-89.)

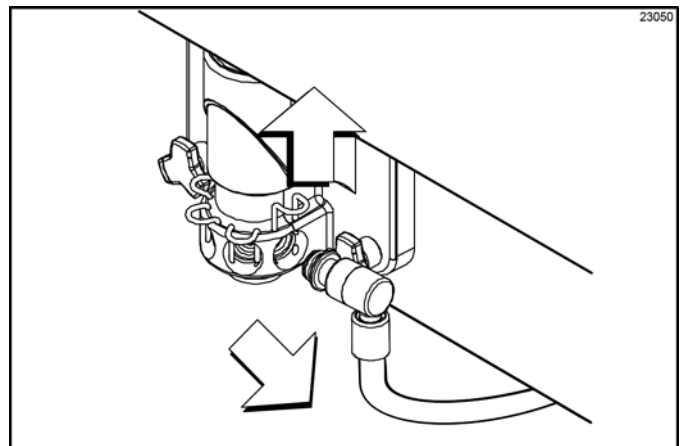



Figure 6-89

- To calibrate the syrup dispensing rate, hold the small portion of the calibration cup under the valve for the flavor to be calibrated. Press the corresponding

Flavor Selection key  to activate the syrup pump and start the flow of syrup. When the syrup level measures one ounce, press the same Flavor

Selection key  to stop the syrup flow.

Verify the level of syrup in the cup. If the measurement is not within the specification, repeat step 4 for the same flavor until the correct syrup calibration is achieved. (See Figure 6-90.)

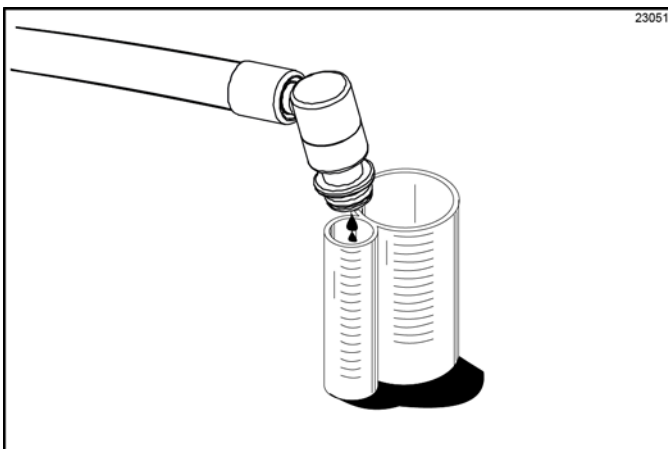





Figure 6-90

Note: You can verify the syrup dispensing rate in the Manager's Menu. (See "VERIFY CALIBRATION" on page 5-9.)

- Repeat step 4 and step 5 for the remaining syrup flavors.
- Exit the Calibration mode by pressing the Calibration

key . A blank screen will appear, and the Auto

key  and the Flavor Selection key  will return to their normal function.

Note: Whenever a particular syrup line is not used, the syrup hole plug found in the spare parts kit must be installed. Place the syrup hole plug O-ring into the groove of the syrup hole plug and lubricate. Install the hole plug in the door. Lower the retaining pin to secure the plug in place.



Syrup Priming Procedure

The purpose of priming the syrup line is to eliminate any air in the syrup delivery system. Air in the syrup line can cause irregular shake blending, flavor carry-over, and syrup leaking from the door spout after the draw valve has closed. Each time a syrup container is drained or replaced, prime the syrup system until all the air has been removed and the syrup flow is uniform.

- Retrieve a full syrup container from the dry storage area.
- Shake the syrup container prior to opening it. Open the full syrup container.
- Pull the feed tube from the empty syrup container and clean the outside of the feed tube with a clean, sanitized towel.

For Syrup Bag System: Disconnect the empty bag and clean the hose connector fitting with a clean, sanitized towel. Attach the hose connector fitting to a full bag of syrup. Place the bag on the shelf in the syrup compartment. Make sure the hose is not pinched and there are no kinks in the tubing.

- Place the feed tube into the full syrup container and replace the syrup container in the syrup cabinet.
- Dispose of the empty syrup container.
- Prime the syrup line by removing the syrup valve from the freezer and hold it over an empty cup.



- Press the Calibration key  to display the menu options. The Calibration key , the Auto key  on the shake side, and the Flavor

Selection key  key will be illuminated.

Note: The screen will display the calibration menu options.

```

UNFLAVORED DRAW
SYRUP CALIBRATION
SYRUP PRIME
EXIT
    
```

8. Press the Auto key  or the Flavor Selection key  to scroll the cursor to SYRUP PRIME.

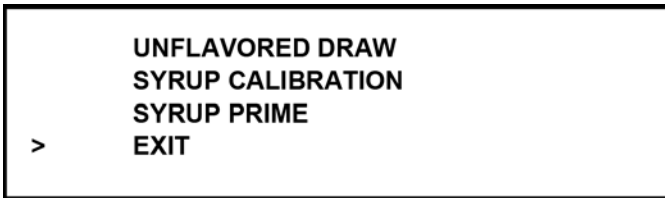

9. Press the Calibration key  to enter the SYRUP PRIME mode.

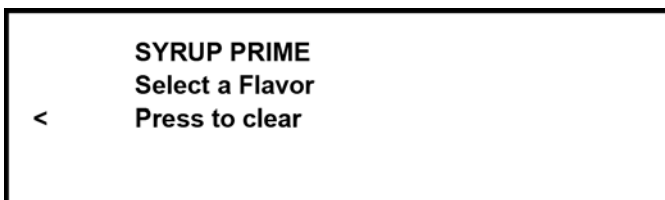

10. Press the corresponding Flavor Selection key . The Flavor Selection key should be illuminated, and the syrup pump for the selected flavor will start running at the maximum speed. (See Figure 6-91.)

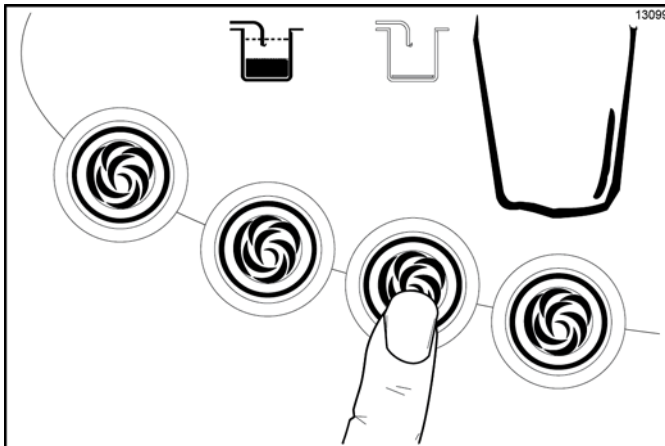



Figure 6-91

11. When a steady stream of syrup is flowing from the syrup valve and all air has been purged from the syrup line, press any Flavor Selection key  to stop the pump.
12. Repeat step 10 and step 11 for any other syrup lines to be primed, or exit the SYRUP PRIME mode by pressing the Calibration key .

Syrup Topping Pump

Syrup Topping Pump Disassembly

Before the first use, and after weekly use, disassemble and clean the pump.

1. Flush and rinse the pump in a container of warm water. Place the lower end of the pump into the water container. Operate the pump until only warm water flows from the discharge tube.
2. Remove the pump from the container of water for disassembly.
3. Remove the plunger assembly from the pump body by turning the plunger nut counterclockwise. (See Figure 6-92.)

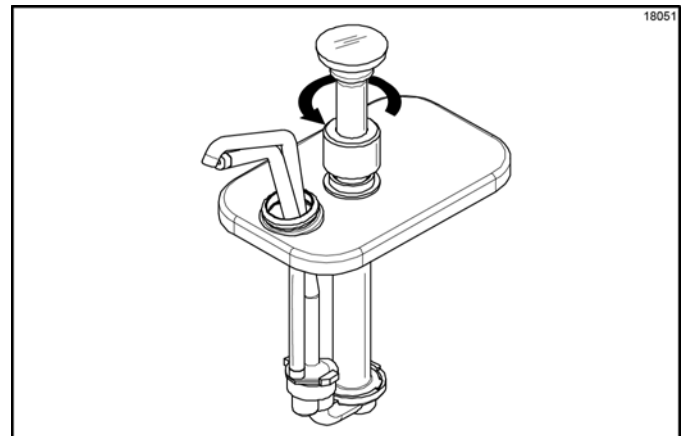

Figure 6-92

4. To remove the knob, compress the spring toward the knob, using the washer. Compress it enough to grab onto the plunger with your hand for support. Begin removing the knob with your other hand. Remove the knob O-ring. Remove the plunger nut from the plunger tube. (See Figure 6-93.)

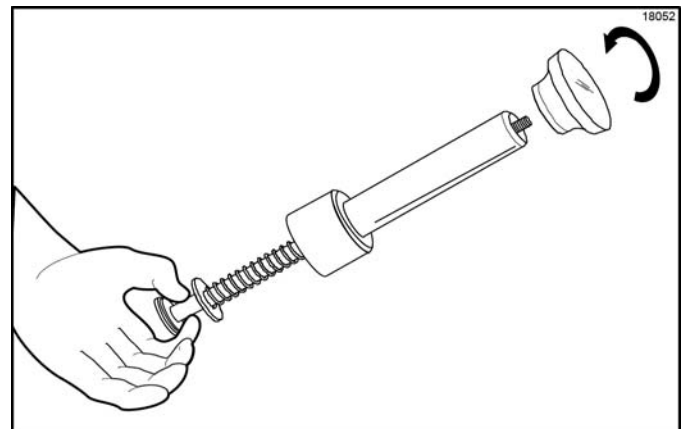

Figure 6-93

OPERATING PROCEDURES

5. Remove the plunger tube and the insert from the plunger assembly. (See Figure 6-94)

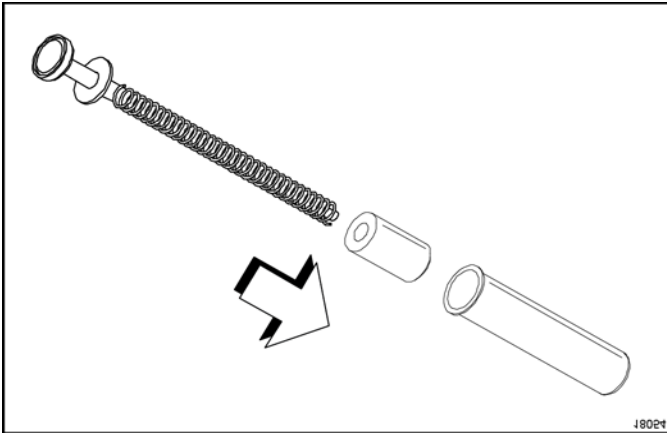

Figure 6-94

6. Remove the spring and washer from the plunger assembly. (See Figure 6-95.)

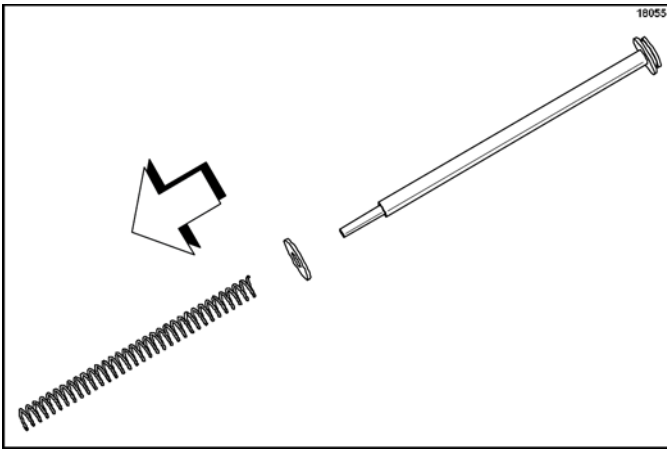

Figure 6-95

7. Remove the seal assembly from the plunger assembly. (See Figure 6-96.)

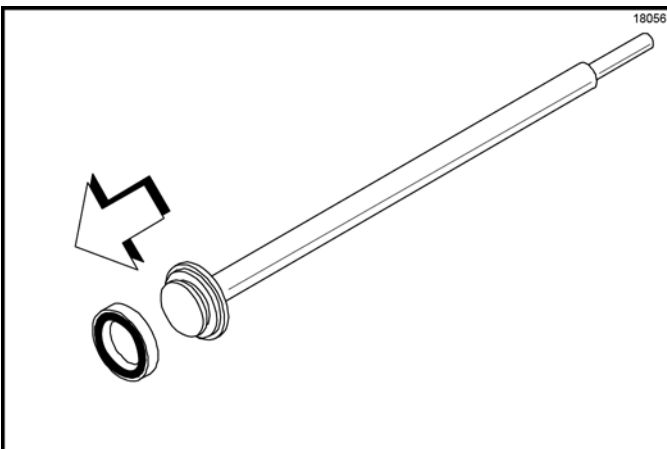

Figure 6-96

8. Remove the seal O-ring from the seal. (See Figure 6-97.)

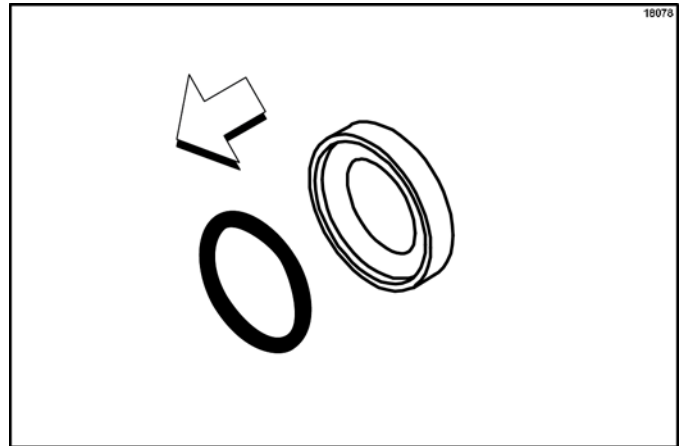

Figure 6-97

9. Remove the discharge tube lock nut by turning it counterclockwise. Remove the discharge lock nut from the discharge tube. (See Figure 6-98.)

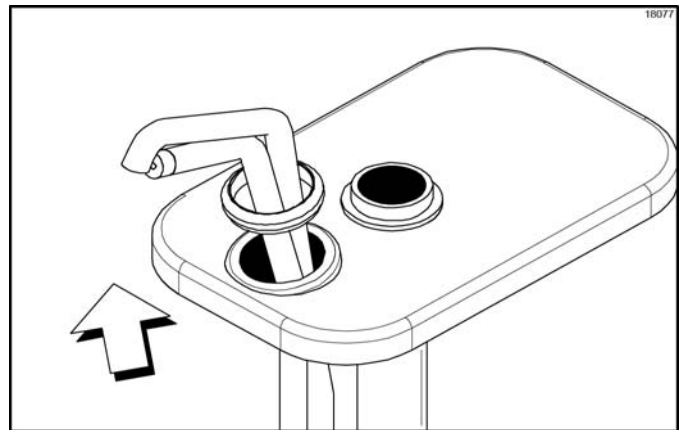

Figure 6-98

10. Remove the lid by sliding it off the discharge tube.

11. Remove the cylinder from the valve body. (See Figure 6-99.)

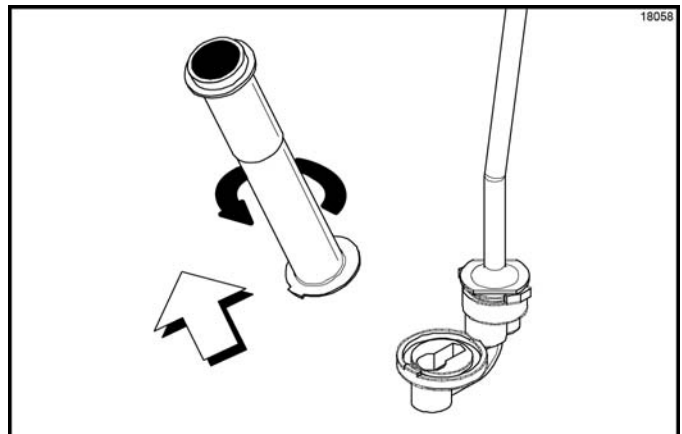

Figure 6-99

- Remove the discharge tube from the valve body.
(See Figure 6-100.)

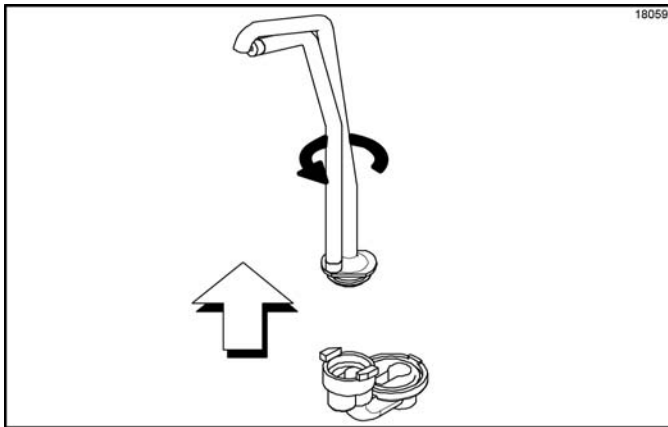

Figure 6-100

- Remove the 1-5/16 in. O-ring from the valve body, and remove the 1 in. O-ring from the discharge tube.

Cleaning the Syrup Pump

- Wash and scrub all parts in an approved 100 PPM cleaning solution (examples: Kay-5[®] or Stera-Sheen[®]).
- Insert the black shielded brush through the tip of the discharge tube. Move the brush back and forth to scrub the tip of the discharge tube. (See Figure 6-101.)

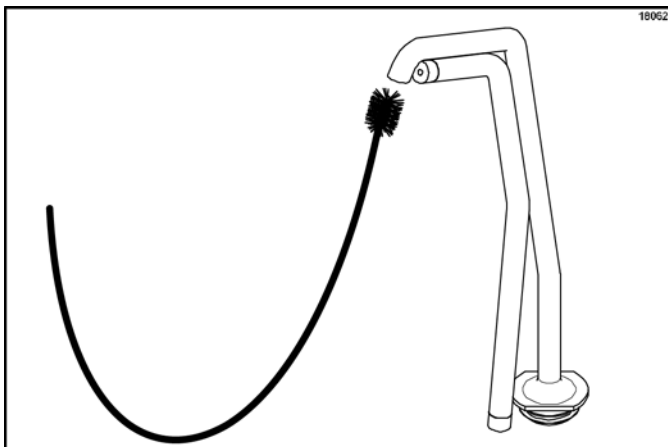

Figure 6-101

- Advance the brush completely through the discharge tube and pull the brush from the bottom of the tube.

- Insert the black shielded brush into the top side of the inlet valve. Scrub this area, specifically around the steel ball. (See Figure 6-102.)

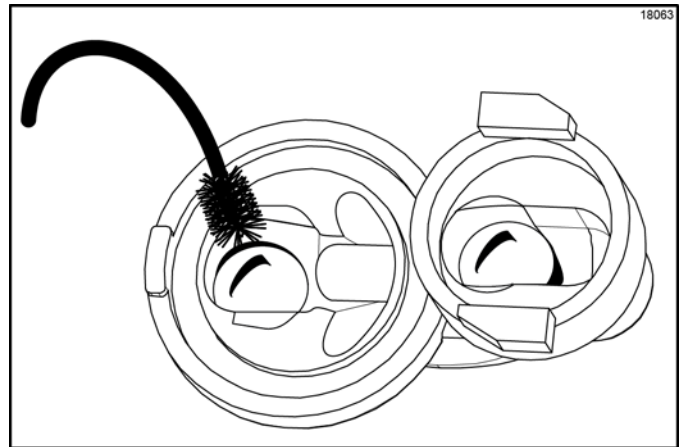

Figure 6-102

- Insert the black shielded brush into the top side of the outlet valve. Scrub this area, specifically around the steel ball. (See Figure 6-103.)

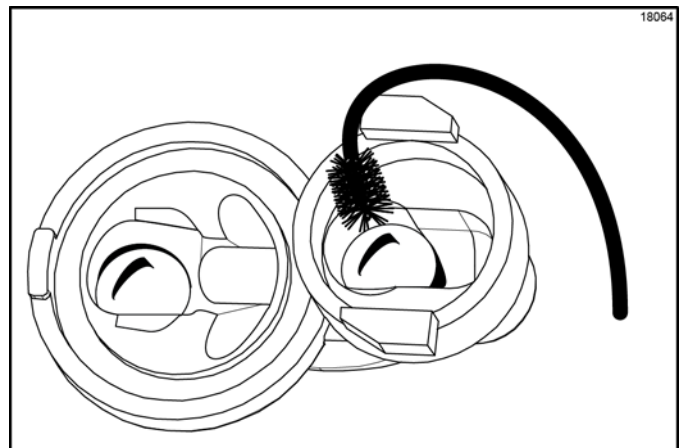

Figure 6-103

- Insert the black shielded brush, by the non-bristle end, into the passageway between the inlet valve and the outlet valve. (See Figure 6-104.)

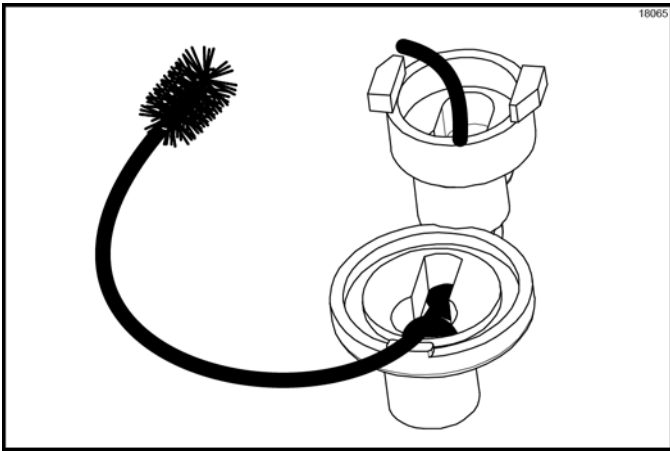

Figure 6-104

7. Move the brush back and forth to scrub this passageway. Advance the brush completely, and pull the brush out of the valve body. (See Figure 6-105.)

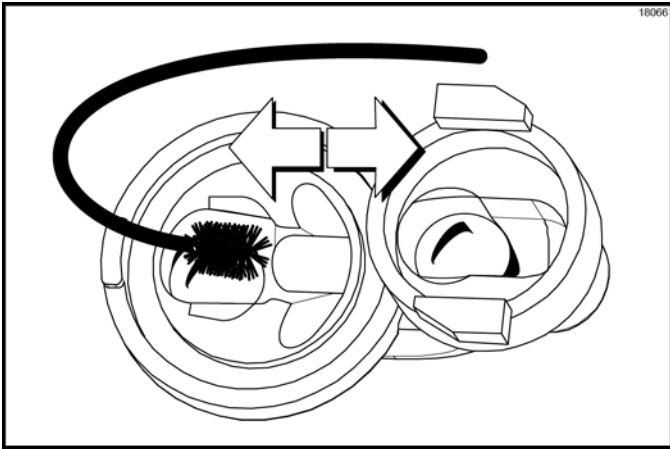

Figure 6-105

8. Insert the black shielded brush into the bottom side of the inlet valve. Move the brush back and forth to scrub this area, specifically around the steel ball. (See Figure 6-106.)

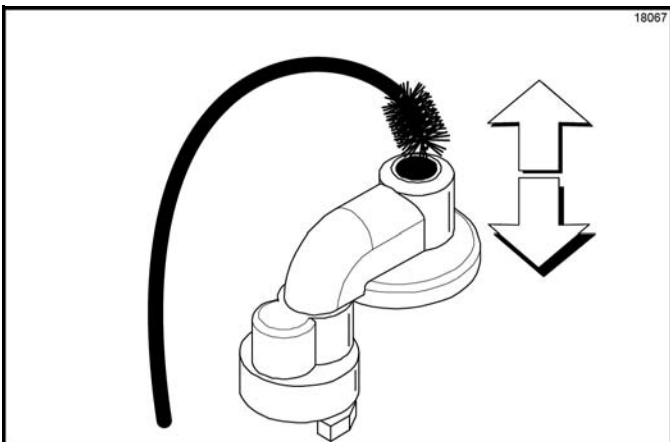

Figure 6-106

9. Advance the brush completely through the inlet valve, and pull the brush out of the valve body.
10. Rinse all parts with clear water.
11. Sanitize the parts in an approved 100 PPM sanitizing solution (examples: Kay-5® or Stera-Sheen®). Allow the parts to air dry after sanitizing.

Syrup Topping Pump Assembly

After pump disassembly and cleaning is complete, assemble the pump.

1. Lubricate and install the seal O-ring into the seal. (See Figure 6-107.)

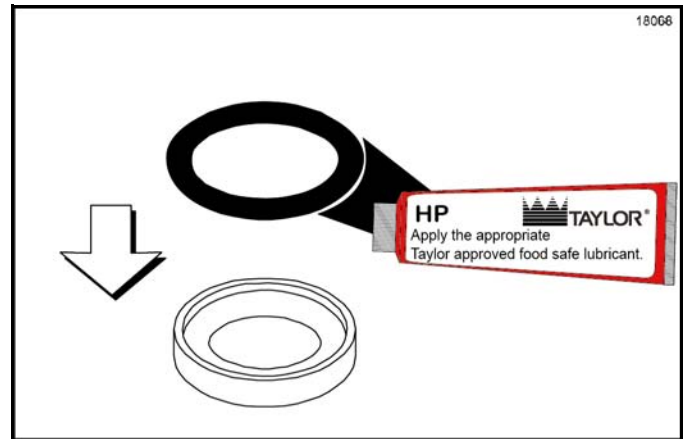

Figure 6-107

2. Install the seal assembly onto the piston end of the plunger assembly.
3. Install the washer and spring onto the plunger assembly. (See Figure 6-108.)

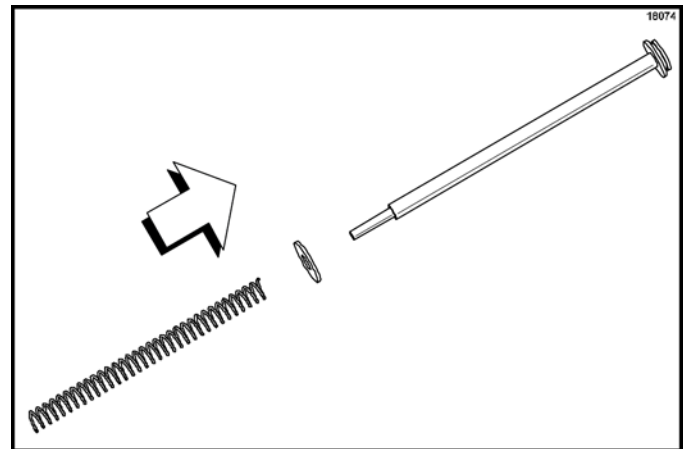

Figure 6-108

4. Install the plunger insert into the plunger tube. The end of the insert with the beveled edge and smaller hole enter the plunger tube first.

5. Install the plunger nut onto the plunger tube.
6. Install the knob O-ring into the groove of the knob.
7. Insert the plunger assembly into the larger opening on the plunger tube. Push the plunger assembly to compress the spring until the threaded end of the stem projects through the smaller opening on the plunger tube and the insert.
(See Figure 6-109.)

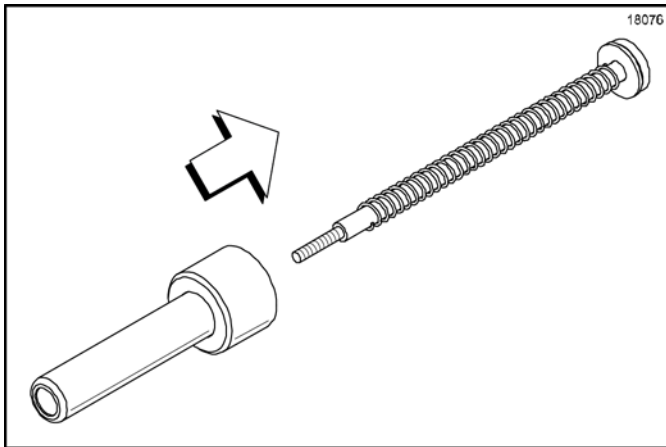

Figure 6-109

8. Install the knob with the knob O-ring onto the threaded end of the plunger assembly. Hold the plunger assembly so that the plunger tube, compressing the spring, is pulled toward the piston end as far as it will go. Tighten the knob by turning it clockwise.
9. Lubricate and install the 1 in. O-ring onto the groove on the discharge tube. (See Figure 6-110.)

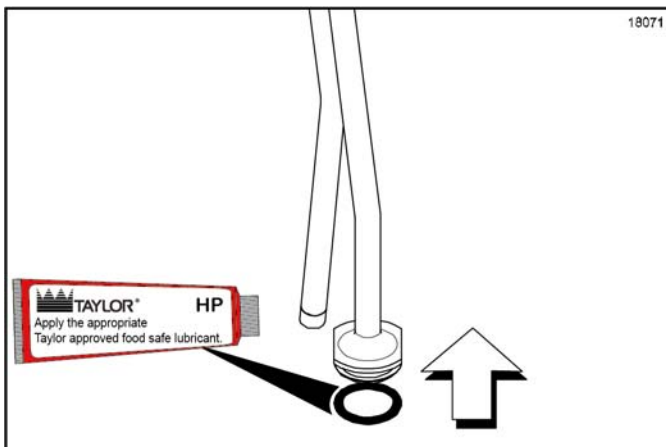

Figure 6-110

10. Lubricate and install the 1-5/16 in. O-ring into the valve body. (See Figure 6-111.)

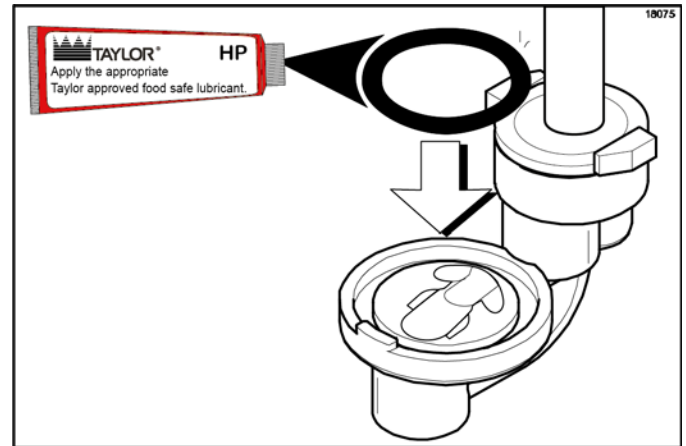

Figure 6-111

11. Install the discharge tube onto the smaller opening in the valve body by aligning the flats on the discharge tube with the locking grooves on the valve body. Push down the discharge tube until it is seated in the valve body opening. Turn the discharge tube clockwise to fully engage it into locking grooves on the valve body.
12. Install the cylinder onto the larger opening in the valve body by tilting the cylinder away from the discharge tube and sliding the widest section of the flange under the center locking groove on the valve body. Align the tabs on the cylinder with the locking grooves on the valve body. Turn the cylinder clockwise until the tabs fully engage into the locking grooves on the valve body.
13. Install the lid by inserting the discharge tube through the smaller hole in the lid. Slide the lid until the larger hole fits around the top of the cylinder. The discharge tube lock nut will secure the lid in position.
14. Install the discharge tube lock nut. Tighten the lock nut by turning it clockwise.

15. Lubricate and install the plunger assembly into the cylinder opening in the pump body.
(See Figure 6-112.)

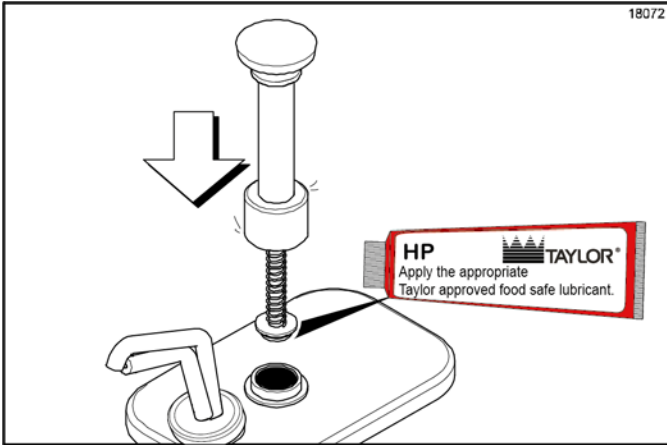

Figure 6-112

16. Tighten the plunger nut by turning it clockwise.
(See Figure 6-113.)

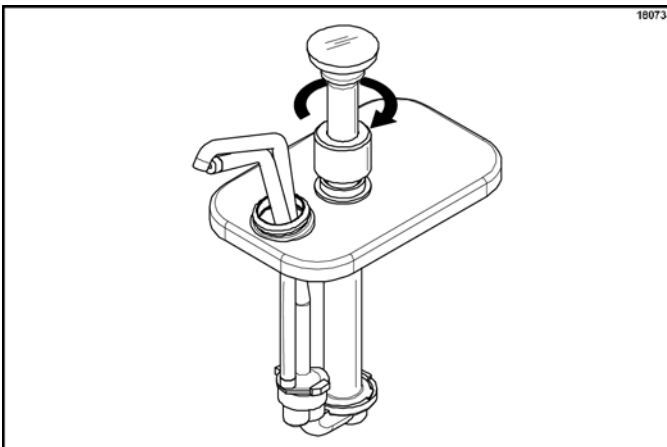

Figure 6-113

Manual Brush Cleaning

Note: This procedure must be completed every 2 weeks.



ALWAYS FOLLOW LOCAL HEALTH CODES.

To disassemble the Model C606, the following items will be needed

- Two cleaning and sanitizing pails for each side of the freezer
- Cleaning brushes (provided with freezer)
- Cleaning solution
- Sanitizing solution
- Single-service towels
- Parts trays

Draining Product from the Freezing Cylinder

To drain the product from the freezing cylinders on both sides of the machine, the steps will be the same. Therefore, first drain the product from the shake side, then go back and duplicate these procedures for the soft serve side.

1. Place the topping heater switches in the OFF position

by pressing the Topping Heater keys . The keys will not be illuminated when the heaters are off.

2. Cancel automatic operation by pressing the Auto



key . (See Figure 6-114.)



Figure 6-114

3. **Shake Side Only:** Remove the shake cup holder. Set it aside for cleaning later with all parts.
4. Remove the hopper cover and agitator. Take these parts to the sink to wash, rinse, and sanitize.
5. With a pail beneath the door spout, press the Wash  and Pump  keys and open the draw valve. (Shake Side: Press any Flavor Selection key to open the draw valve.)
Drain the product from the freezing cylinder and the mix hopper. (See Figure 6-115.)

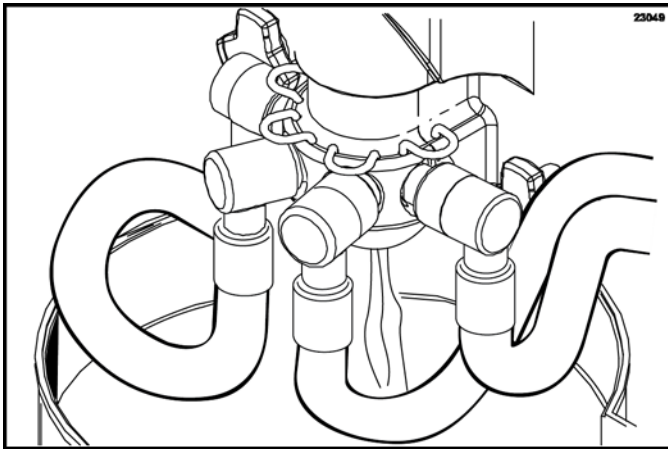



Figure 6-115

6. When the flow of product stops, press the Wash  and Pump  keys, canceling the Wash and Pump modes. The shake draw valve will automatically close when the wash operation is cancelled.
7. Remove the locking clip, mix feed tube, pump clip, and assembled air/mix pump. Place the parts onto the parts tray.
8. **Shake Side Only:** Remove the syrup lines from the freezer door by raising the syrup valve retainers and pulling the valves straight out of the door. Insert the syrup hole plugs in the syrup ports. Lower the retainer pins to secure the hole plugs in the door.
9. Repeat step 2 through step 7 for the soft serve side of the freezer.

Rinsing

1. Pour 2 gal. (7.6 L) of cool, clean water into the shake mix hopper. With the white hopper brush, scrub the mix hopper, mix-level sensing probes, and the outside of the agitator driveshaft housing. Using the double-ended brush, brush clean the mix inlet hole. (See Figure 6-116.)

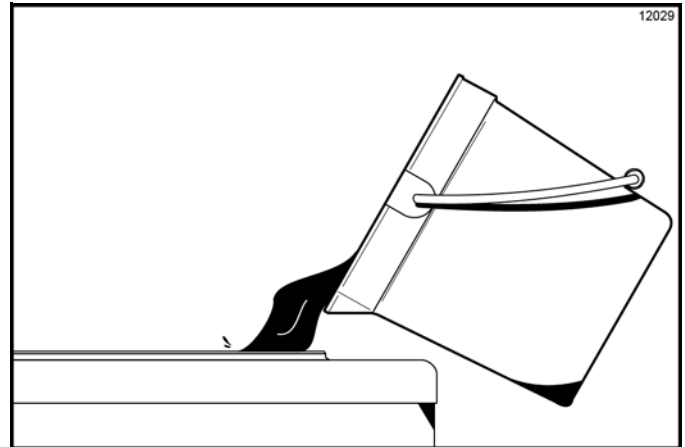



Figure 6-116

Note: *Do not brush clean the mix inlet hole while the machine is in the Wash mode.*

2. With a pail beneath the door spout, press the Wash  key. (See Figure 6-117.)

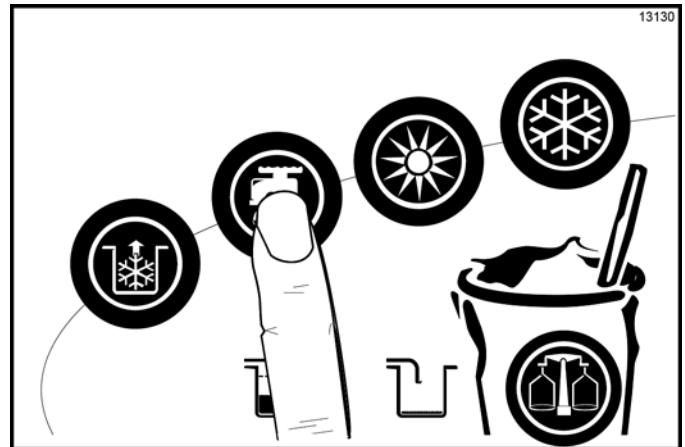



Figure 6-117

3. Open the draw valve on the freezer door. Drain all the rinse water from the door spout, close the draw valve, and press the Wash  key, canceling the Wash mode. (Note: The shake draw valve will automatically close when the wash operation is canceled.)

- Repeat this procedure using clean, warm water until the water being discharged is clear.
- Repeat step 1 through step 4 for the soft serve side of the freezer.



Cleaning and Sanitizing

- Prepare a pail of an approved 100 PPM cleaning solution (examples: 2-1/2 gal. [9.5 L] of Kay-5[®] or 2 gal. [7.6 L] of Stera-Sheen[®]).

Important! Use warm water and follow the manufacturer's specifications.

- Pour the cleaning solution into the hopper and allow it to flow into the freezing cylinder.
- Using the white hopper brush, clean the mix hopper, mix-level sensing probes, and the outside of the agitator driveshaft housing. Using the double-ended brush, clean the mix inlet hole.

Note: Do not brush clean the mix inlet hole while the machine is in the Wash mode.

- Press the Wash  key. This will cause the cleaning solution in the freezing cylinder to come in contact with all areas of the freezing cylinder.
- Place an empty pail beneath the door spout.
- Open the draw valve on the freezer door and draw off all the solution.
- Once the cleaner stops flowing from the door spout, close the draw valve and press the Wash key , canceling the Wash mode.

Note: The shake draw valve will automatically close when the wash operation is canceled.

- Prepare a pail of an approved 100 PPM sanitizing solution (examples: 2-1/2 gal. [9.5 L] of Kay-5[®] or 2 gal. [7.6 L] of Stera-Sheen[®]).
- Important!** Use warm water and follow the manufacturer's specifications.
- Repeat step 2 through step 8 with the sanitizing solution.
 - Repeat step 1 through step 9 for the soft serve side of the freezer.

Disassembly—Shake Side

Note: Failure to remove the parts specified below for brush cleaning and lubrication will result in damage to the machine. These parts must be removed every 14 days, or the machine will lock out and will not operate.

- Make sure the power switch is in the OFF position. (See Figure 6-118.)

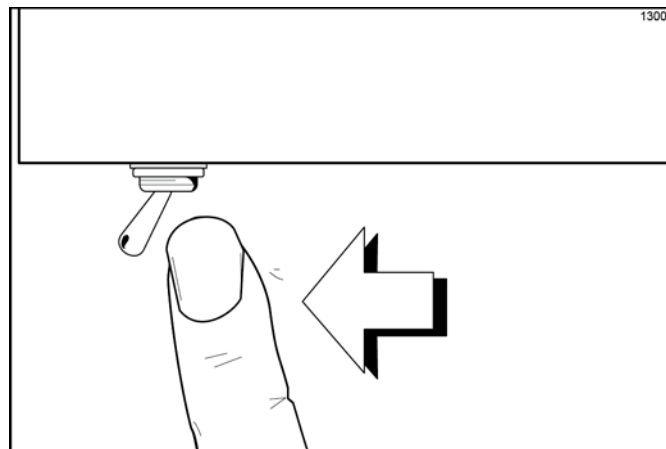

Figure 6-118

- Remove the hole plugs from the syrup ports, and remove the restrictor cap from the bottom of the door spout.
- Remove the spinner blade from the bottom of the door spout by lifting up the locking collar on the spinner coupling and pulling down the blade.
- Remove the handscrews, freezer door, beater assembly, driveshaft, driveshaft seal, and scraper blades from the freezing cylinder.
- Remove the driveshaft seal from the driveshaft.
- Remove the freezer door O-ring, front bearing, retainer pins, and draw valve spinner assembly. Remove the driven spinner from the draw valve by grasping the draw valve and pulling the driven spinner out. Remove the spinner shaft seal. (See Figure 6-119.)

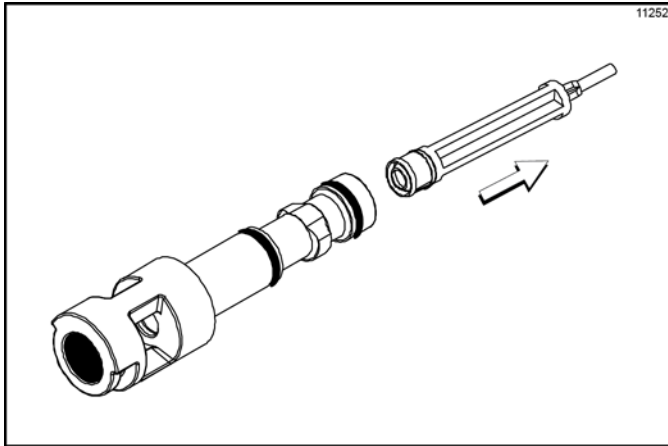

Figure 6-119

- Remove the two O-rings from the draw valve.

Note: To remove O-rings, use a clean, sanitized towel to grasp the O-ring. Apply pressure in an upward direction until the O-ring pops out of its groove. With the other hand, push the top of the O-ring forward. It will roll out of the groove and can easily be removed. If there is more than one O-ring to be removed, always remove the rear O-ring first. This will allow the O-ring to slide over the forward O-rings without falling into the open grooves.

- From the shake pump cylinder, remove the retaining pin, mix inlet adaptor, valve cap, pump gasket, and piston. Remove the O-ring from the piston and valve cap.
- Remove the pump driveshaft from the drive hub in the rear wall of the mix hopper. (See Figure 6-120.)

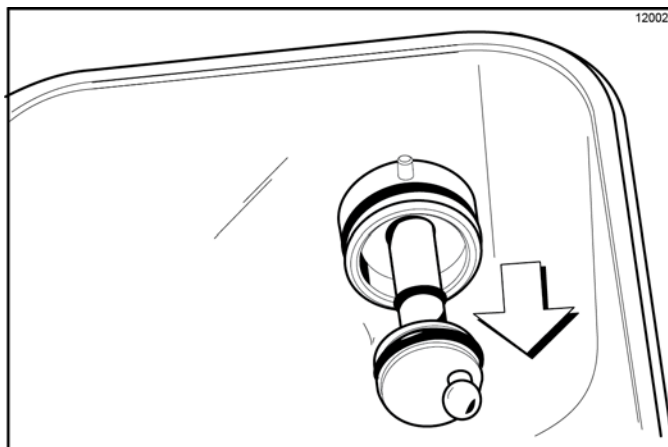

Figure 6-120

Remove the two small O-rings and one large O-ring from the pump driveshaft.

Disassembly—Soft Serve Side

Note: Failure to remove the parts specified below for brush cleaning and lubrication will result in damage to the machine. These parts must be removed every 14 days, or the machine will lock out and will not operate.

- Make sure the power switch is in the OFF position.
- Remove the handscrews, freezer door, beater, scraper blades, and driveshaft with driveshaft seal from the freezing cylinder.
- Remove the driveshaft seal from the driveshaft.
- From the soft serve pump cylinder, remove the retaining pin, mix inlet adaptor, valve cap, pump gasket, and piston. Remove the O-ring from the piston and valve cap.
- Remove the freezer door gasket, front bearing, pivot pin, draw handle, and draw valve. Remove the three O-rings from the draw valve.

Note: Do not attempt to remove the star design from the door. The star design is part of the door and is **not** a removable piece. (See Figure 6-121.)

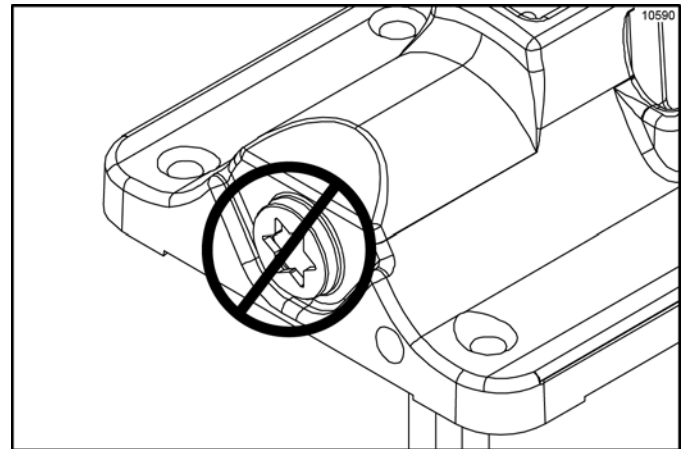

Figure 6-121

- Remove the pump driveshaft from the drive hub in the rear wall of the mix hopper. (See Figure 6-122.)

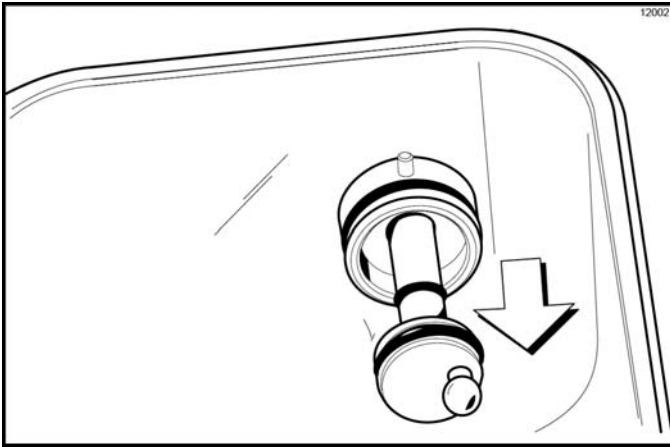

Figure 6-122

Remove the two small O-rings and one large O-ring from the pump driveshaft.

7. Remove the front drip tray and splash shield. Remove the ladles from the two cold topping containers.
8. Remove the long drip pan from the front panel. Take it to the sink for cleaning. (See Figure 6-123.)

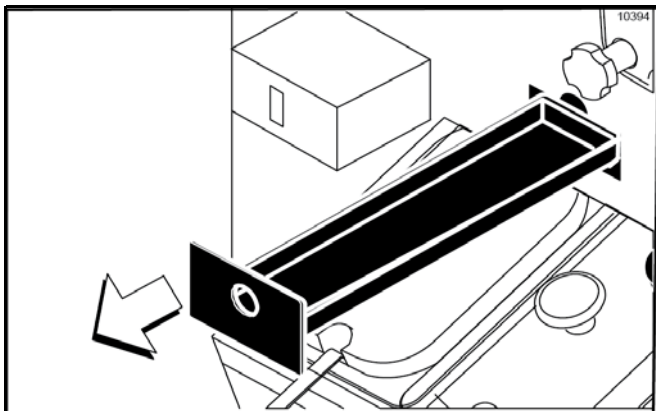

Figure 6-123

9. Remove the two short drip pans from the rear panel. Remove the two notched drip pans from the left and right side panels. Take them to the sink for cleaning. (See Figure 6-124.)

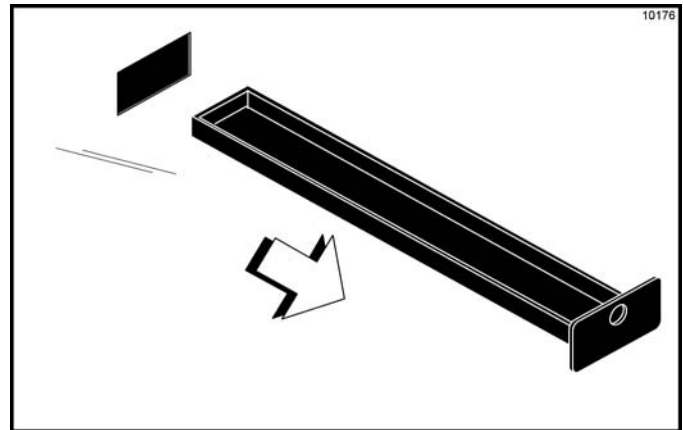

Figure 6-124

Note: If the drip pans are filled with an excessive amount of mix, the driveshaft seal(s) or O-ring(s) should be replaced or properly lubricated.

Brush Cleaning

We recommend brush cleaning all the shake parts, then duplicating these steps where they apply for the soft serve parts. By doing so, you will not confuse or interchange these parts for assembly the next morning. Place the parts in their proper places in the parts tray.

1. Prepare a sink with an approved 100 PPM cleaning solution (examples: Kay-5[®] or Stera-Sheen[®]).
Important! Use warm water and follow the manufacturer's specifications.
Make sure all brushes provided with the freezer are available for brush cleaning.
2. Thoroughly brush clean all disassembled parts and parts trays in the cleaning solution, making sure all lubricant and mix film is removed. Make sure to brush all surfaces and holes, especially the holes in the pump components and the small syrup holes in the shake freezer door.
Rinse all parts with clean, warm water, one tray at a time, including the tray.
3. Return to the freezer with a small amount of cleaning solution. Using the black brush, clean the rear shell bearings at the back of the freezing cylinders. (See Figure 6-125.)

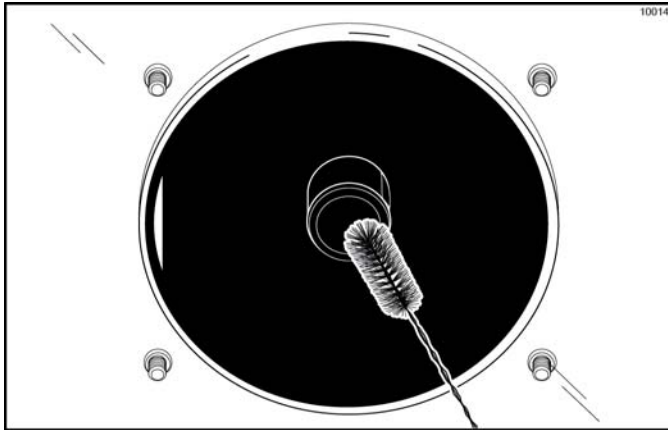

Figure 6-125

4. Using the black brush, clean the drive hub openings in the rear wall of the mix hoppers. (See Figure 6-126.)

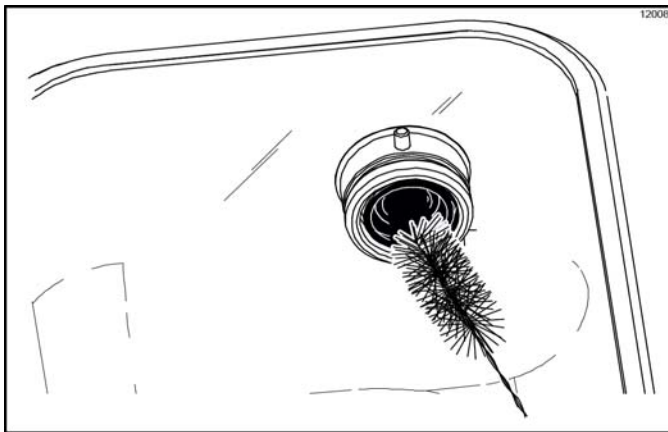

Figure 6-126

5. Using the double-ended brush, brush clean the syrup line fittings.
6. Prepare a sink with an approved 100 PPM sanitizing solution (examples: Kay-5® or Stera-Sheen®).
Important! Use warm water and follow the manufacturer's specifications.
7. Sanitize all parts in the sanitizing solution for a minimum of 1 minute.
8. Repeat step 3 with the sanitizing solution.
9. Place disassembled parts on a clean and sanitized parts trays.
10. Wipe all exterior surfaces of the freezer with a clean, sanitized towel.
11. Repeat step 1 through step 10 for the soft serve side of the freezer.

Syrup System—Scheduled Maintenance

Syrup Pump Tube Removal

1. Remove the pickup tubes from the syrup containers. Wipe the outside of the tubes with a clean, sanitized towel.

For Syrup Bag System: Disconnect the syrup bag fitting from each bag.

2. Remove the syrup containers and the pump cover tray from inside the cabinet.
3. Place the pickup tubes in a pail of an approved 100 PPM cleaning solution (examples: Kay-5® or Stera-Sheen®).

Important! Use warm water and follow the manufacturer's specifications.



To avoid contamination, cover the syrup containers with a plastic wrap.

For Syrup Bag System: Place the syrup hose with the bag connection fitting in a pail of an approved 100 PPM cleaning solution (examples: Kay-5® or Stera-Sheen®).

Important! Use warm water and follow the manufacturer's specifications.

4. Raise the retainer and remove the syrup valve from the freezer door. Place the valve in a pail located under the draw valve.

5. Select the Calibration key  on the control panel to display the menu options.

6. Press the Auto key  to move the cursor to SYRUP PRIME. Press the Calibration key  again to display the SYRUP PRIME screen.

7. Select the Flavor Selection key  for the corresponding syrup valve to start the flow of cleaning solution through the syrup line.
8. Allow the cleaning solution to flow until all of the syrup is flushed from the line.
9. Once the line is free of syrup, remove the pickup tube from the cleaning solution and continue to run the

OPERATING PROCEDURES

pump until the syrup line is free from liquid.

Select the Flavor Selection key  to stop the pump.

- Repeat step 3 through step 9 using an approved 100 PPM sanitizing solution (examples: Kay-5[®] or Stera-Sheen[®]).

Important! Use warm water and follow the manufacturer's specifications.

- Open the pump by pushing up on the hinged cover. (See Figure 6-127.)

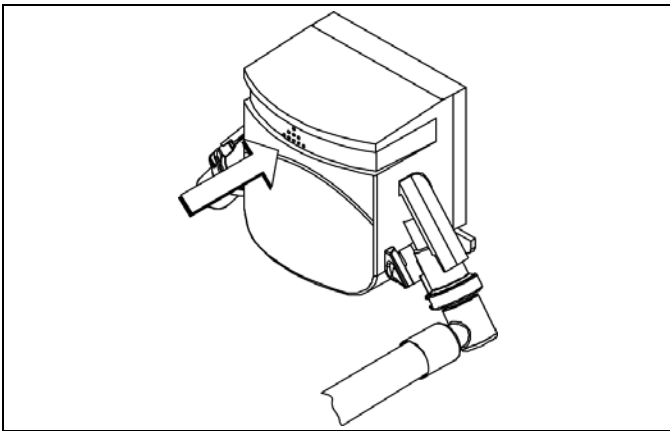

Figure 6-127

- Grasp the pump tube by both ends and remove it from the pump body. (See Figure 6-128.)

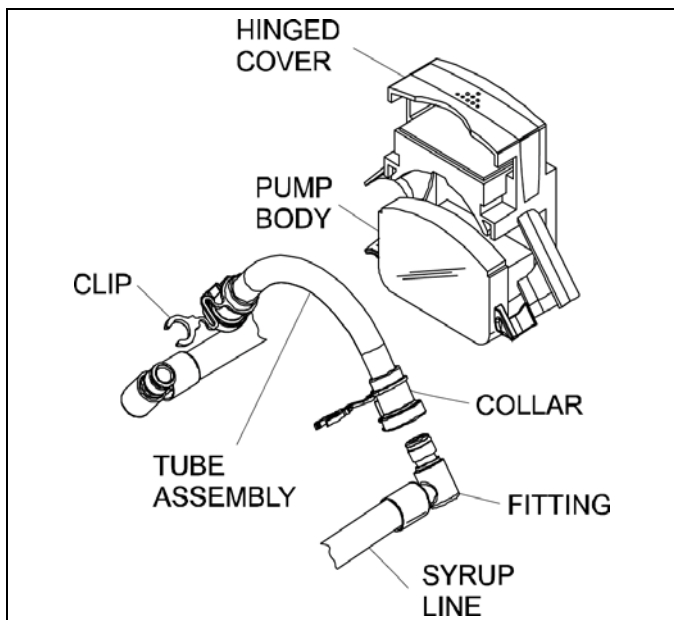

Figure 6-128

- Remove the clips from their respective collars.
- Remove the fittings from the pump tube.

Pump Tube Installation

- Lubricate the O-rings on the syrup line fittings with Taylor Lube HP.

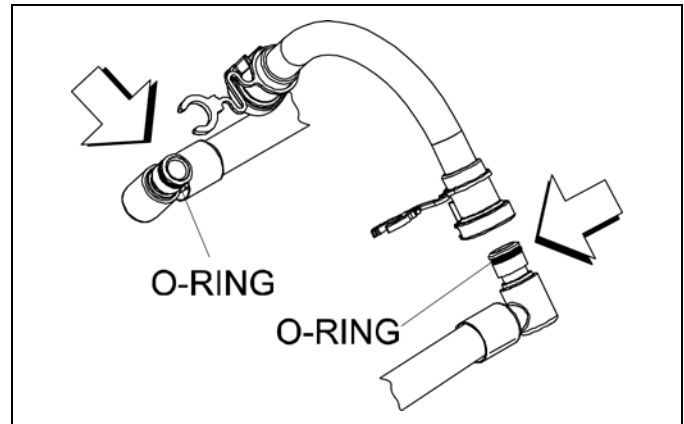

Figure 6-129

- Press the fittings into the new pump tube.
- Install the clips into their respective collars.
- Using your hands, rotate the pump rollers so they are in the 10 o'clock and 2 o'clock positions.
- Place the tube assembly into the pump body. (Make sure the syrup lines are pushed through the rear of the cabinet.)
- Push down on the top of the pump to close it.
- Replace the pump cover tray and the syrup containers.
- Prime the syrup lines.
- Calibrate the syrup system. (See "Syrup System" on page 6-25.)

Syrup Line Cleaning/Sanitizing – Weekly

- Remove the pickup tubes from the syrup containers. Wipe the outside of the tubes with a clean, sanitized towel.

For Syrup Bag System: Disconnect each syrup bag and clean the hose connector fitting with a clean, sanitized towel.

- Prepare a pail of an approved 100 PPM cleaning solution (examples: 2-1/2 gal. [9.5 L] of Kay-5[®] or 2 gal. [7.6 L] of Stera-Sheen[®]).

Important! Use warm water and follow the manufacturer's specifications.



Place the pickup tubes in the pail.

For Syrup Bag System: Place the syrup hose with the bag connection fitting in the pail of approved 100 PPM cleaning solution (examples: Kay-5® or Stera-Sheen®).

Important! Use warm water and follow the manufacturer's specifications.

3. Raise the retainer and remove the syrup valve from the freezer door. Place the valve in a pail located under the draw valve.

4. Select the Calibration key  on the control panel to display the menu options.

5. Press the Auto key  to move the cursor to SYRUP PRIME. Press the Calibration key  again to display the SYRUP PRIME screen.

6. Select the Flavor Selection key  for the corresponding syrup valve to start the flow of cleaning solution through the syrup line.

7. Allow the cleaning solution to flow until all the syrup is flushed from the line.

8. Press the Flavor Selection key  to stop the flow of cleaning solution.

9. Repeat step 2 through step 8 using an approved 100 PPM sanitizing solution (examples: Kay-5® or Stera-Sheen®).

Important! Use warm water and follow the manufacturer's specifications.

10. Remove the syrup nose fitting from the syrup valve by turning the cap counterclockwise.

11. Remove the duckbill valve and the O-ring from the syrup nose fitting.

12. Using the white end of the double-ended brush, scrub the inside of the syrup nose fitting and the syrup line fitting to remove any residual particles.

13. Using a shake cup filled with an approved 100 PPM sanitizing solution, rinse the syrup valve fitting thoroughly.

14. Using a clean, sanitized towel, gently wipe any syrup from the duckbill valve.

15. Install the duckbill valve into the syrup nose fitting, with the flat end aligned with the open slot in the syrup nose fitting.

Note: Replace the duckbill valve if it is damaged or extends past the syrup nose fitting slot. (See Figure 6-130.)

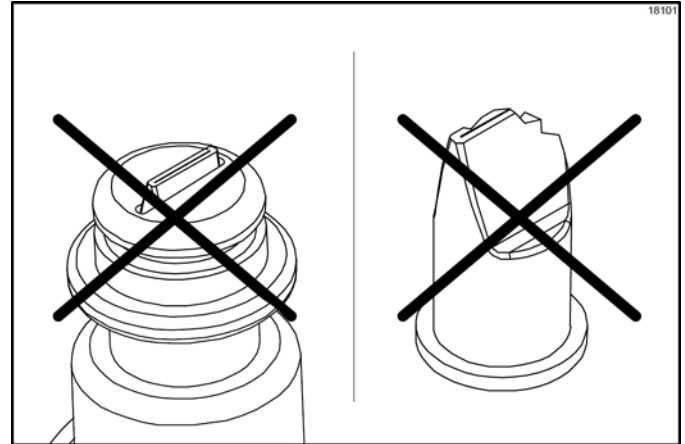

Figure 6-130

16. Install the syrup nose fitting onto the syrup line fitting. Tighten by hand until secured.

Note: The duckbill valve must be wet when the syrup nose fitting is assembled on the syrup line fitting. The sanitized water will lubricate the bottom flat surface and prevent the duckbill from twisting when the syrup nose fitting is tightened.

17. Inspect the duckbill valve for proper installation inside the syrup nose fitting. The tip of the duckbill valve must be flat to seal the syrup line. (See Figure 6-131.)

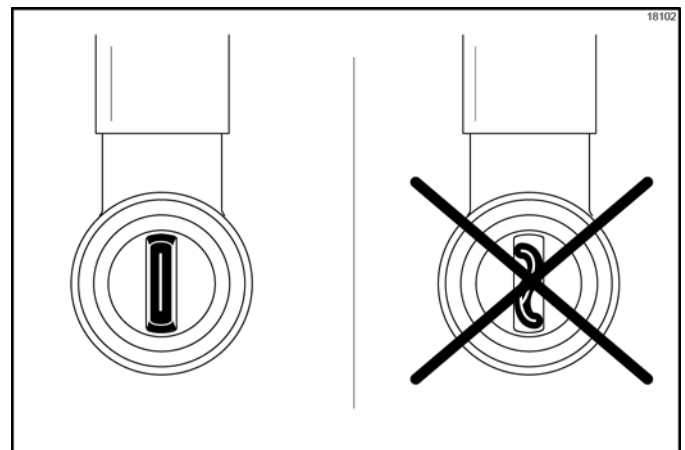



Figure 6-131

OPERATING PROCEDURES



If the tip is not flat, remove the syrup nose fitting and remove/reinstall the duckbill valve. Using a shake cup filled with sanitizing solution, rinse the syrup nose fitting to wet the bottom of the duckbill valve. Reinstall the syrup nose fitting onto the syrup line fitting. If the tip will not remain flat when the syrup fitting is assembled, replace the duckbill valve.

18. Install the O-ring on the syrup nose fitting.
19. Repeat step 3 through step 18 for all syrup flavors.
20. Remove the pickup tubes from the pail of sanitizing solution and allow them to drain.
21. Place all the pickup tubes into the syrup containers. Ensure the syrup lines match their respective flavors.
For Syrup Bag System: Attach the bag connector fitting to the proper syrup flavor.

22. Select the Calibration key  on the control panel to display the menu options.

23. Press the Auto key  to move the cursor to

SYRUP PRIME. Press the Calibration key  again to display the Syrup Prime screen.

24. Select the Flavor Selection key  for the corresponding syrup valve to start the flow of syrup.
25. Allow the syrup to flow until all of the sanitizing solution and air is purged from the line.
26. Press the Flavor Selection key  to stop the flow of syrup.
27. Lubricate the O-ring on the syrup nose fitting. Install the syrup valve into the shake door. Secure the valve by lowering the retainer.
28. Repeat step 20 through step 27 for all syrup flavors.
29. Clean the syrup cabinet interior with a clean, sanitized towel. Spray resistant areas with the sanitizing solution.

During Cleaning and Sanitizing



ALWAYS FOLLOW LOCAL HEALTH CODES.

Cleaning and sanitizing schedules are governed by your state or local regulatory agencies and must be followed accordingly. The following checkpoints should be stressed during the cleaning and sanitizing operations.

Important! *Cleaning and sanitizing must be performed every 2 weeks.*

Troubleshooting Bacterial Count

- Thoroughly clean and sanitize the machine regularly, including complete disassembly and brush cleaning.
- Use all brushes supplied for thorough cleaning. The brushes are specially designed to reach all product passageways.
- Use the white bristle brush to clean the mix inlet hole which extends from the mix hopper down to the rear of the freezing cylinder.
- Use the black bristle brush to thoroughly clean the rear shell bearing located at the rear of the freezing cylinder. Use a generous amount of cleaning solution on the brush.
- Properly prepare the cleaning and sanitizing solutions. Read and follow label directions carefully. Too strong of a solution may damage the parts and too weak of a solution will not do an adequate job of cleaning or sanitizing.
- The temperature of the mix in the mix hopper and walk-in cooler should be below 40°F (4.4°C).
- Discard the remaining mix from the freezer during closing procedures.

Regular Maintenance Checks

- Replace scraper blades that are nicked or damaged. Before installing the beater assembly, make sure the scraper blades are properly attached to the helix.
- Check the rear shell bearing for signs of wear (excessive mix leakage in rear drip pan) and make sure it is properly cleaned.
- Using a screwdriver and cloth towel, keep the rear shell bearing and the female hex drive socket clean and free of lubricant and mix deposits.
- Dispose of O-rings and seals if they are worn, torn, or fit too loosely, and replace them with new ones.
- Follow all lubricating procedures. (See “Machine Setup” on page 6-1.)



WARNING! Always disconnect electrical power prior to cleaning the condenser. Failure to follow this instruction may result in electrocution.

- If your machine is air-cooled, check the condensers for accumulation of dirt and lint. Dirty condensers will reduce the efficiency and capacity of the machine. Condensers should be cleaned **monthly** with a soft brush. **Never** use screwdrivers or other metal probes to clean between the fins.

Note: *For machines equipped with an air filter, it will be necessary to vacuum clean the filters on a monthly schedule.*

- If your machine is water-cooled, check the water lines for kinks or leaks. Kinks can occur when the machine is moved back and forth for cleaning or maintenance purposes. Deteriorated or cracked water lines should be replaced by an authorized Taylor technician only.

Winter Storage

If the place of business is to be closed during the winter months, it is important to protect the freezer by following certain precautions, particularly if the building is subject to freezing conditions.

Disconnect the freezer from the main power source to prevent possible electrical damage.

On water-cooled freezers, disconnect the water supply. Relieve pressure on the spring in the water valve. Use air pressure on the outlet side to blow out any water remaining in the condenser. **This is extremely important.** Failure to follow this procedure may cause severe and costly damage to the refrigeration system.

Your local Taylor distributor can perform this winter storage service for you.

Wrap detachable parts of the freezer, such as the beater, blades, driveshaft, and freezer door, and place them in a protected dry place. Rubber trim parts and gaskets can be protected by wrapping them with moisture-proof paper. All parts should be thoroughly cleaned of dried mix or lubrication, which can attract mice and other vermin.

Note: *It is recommended that an authorized service technician perform winter storage draining, to ensure all water has been removed. This will guard against freezing and rupturing of the components.*

Table 8-1

Problem	Shake Side Probable Cause	Soft Serve Side Probable Cause	Either Side Probable Cause	Remedy	Page Ref.
<p>1. Soft lock message appears on display.</p>			<p>a. A machine fault has occurred.</p>	<p>a. Determine reason the failure occurred. Correct cause for failure, then select Heat key to start a heat cycle or Wash to disassemble and brush-clean the machine.</p>	<p>page 5-6</p>
			<p>b. More than 24 hours since the last heat cycle.</p>	<p>b. The freezer must go through a heat cycle every 24 hours. The freezer must now be disassembled and brush-cleaned or placed in a heat cycle.</p>	<p>page 5-6</p>
			<p>c. The power switch is in the OFF position.</p>	<p>c. The power switch must be in the ON position. The freezer must now be disassembled and brush cleaned or placed in a heat cycle.</p>	<p>page 5-6</p>
			<p>d. The freezer is not in the Auto or Standby mode when the heat cycle was programmed to start.</p>	<p>d. The freezer must be in the Auto or Standby mode. The freezer must now be disassembled and brush-cleaned or placed in a heat cycle.</p>	<p>page 5-6</p>
			<p>e. Mix out condition.</p>	<p>e. The level of mix in the mix hopper must be up to the fill level indicator on the agitator paddle. The freezer must now be disassembled and brush-cleaned, or placed in a heat cycle.</p>	<p>page 5-6</p>
			<p>f. The agitator is not installed.</p>	<p>f. The agitator must be cleaned and installed before starting the heat cycle. The freezer must now be disassembled and brush-cleaned or placed in a heat cycle.</p>	<p>page 6-16 page 6-19</p>

Problem	Shake Side Probable Cause	Soft Serve Side Probable Cause	Either Side Probable Cause	Remedy	Page Ref.
2. Hard lock message appears on display.			<p>a. Brush clean interval exceeded.</p> <p>b. A barrel or hopper thermistor is faulty.</p>	<p>a. The freezer must be disassembled and brush-cleaned within 24 hours when the counter indicates 1 day remaining.</p> <p>b. Contact an authorized service technician.</p>	<p>page 5-5</p> <p>- - -</p>
3. No product is being dispensed.	<p>i. Menu is displayed making flavor select keys inoperative.</p>		<p>a. Low on mix. The Mix Out light is on.</p> <p>b. The power switch is in the OFF position.</p> <p>c. Machine not in Auto mode.</p> <p>d. Beater motor is out on reset, BEATER OVERLOAD message displayed.</p> <p>e. The pump motor is not running in the Auto mode.</p> <p>f. Freeze-up in mix inlet hole.</p> <p>g. The mix pump ball crank is broken.</p> <p>h. Feed tube or check ring not properly installed.</p>	<p>a. Add mix to the mix hopper. Return to Auto mode.</p> <p>b. Place the power switch to ON and select Auto mode.</p> <p>c. Select Auto and allow machine to cycle off before drawing product.</p> <p>d. Contact an authorized service technician.</p> <p>e. Push the pump reset button. Check pump motor is operating when the draw valve is raised.</p> <p>f. Contact an authorized service technician.</p> <p>g. Contact an authorized service technician.</p> <p>h. Make sure feed tube and rubber check ring are properly installed.</p> <p>i. Exit the menu by moving the cursor arrow to Exit and pressing the Calibration key. This will restore the control keys to their normal function.</p>	<p>page 6-14 page 6-15</p> <p>page 6-14 page 6-15</p> <p>- - -</p> <p>page 5-3</p> <p>- - -</p> <p>- - -</p> <p>page 6-10</p> <p>page 6-25</p>

Problem	Shake Side Probable Cause	Soft Serve Side Probable Cause	Either Side Probable Cause	Remedy	Page Ref.
	j. Draw valve not opening.			j. Draw valve not aligned with actuator bracket when freezer door installed. Reassemble with correct alignment.	page 6-4
4. The product is too soft.	a. Too much syrup - 1 fl. oz. (30 mL) in 5 seconds. For triple thick shake syrup: 1 fl. oz. (30 mL) ±1/8 oz. (4 mL) in 7 seconds.		b. Draw rate is set too fast.	a. Calibrate the syrups. b. Adjust draw rate of 5 oz. to 7-1/2 oz. (142 g to 213 g) of product by weight in 10 seconds.	page 6-25 page 5-3
5. The product is too thick.	a. Not enough syrup - 1 fl. oz.(30 mL) in 5 seconds. For Triple Thick Shake Syrup: 1 fl.oz. (30 mL) ± 1/8 oz (4 mL) in 7 seconds.		b. Freezing cylinder not primed correctly. c. Air/mix pump incorrectly assembled. d. The viscosity control is set too cold. e. Freeze-up in mix inlet hole.	a. Calibrate the syrups. Check that the syrup containers are not empty. b. Drain the freezing cylinder and reprime the machine. c. Follow assembly procedures carefully. d. Contact an authorized service technician. e. Contact an authorized service technician.	page 6-25 page 6-14 page 6-15 page 6-8 - - - - - -
6. The mix in the hopper is too warm.			a. Hopper cover is not in position. b. The agitator is not installed. c. The hopper temperature is out of adjustment.	a. Clean and sanitize hopper cover and place in position. b. Clean and sanitize the agitator and install. c. Contact an authorized service technician.	page 6-15 page 6-13 page 6-34 - - -

Problem	Shake Side Probable Cause	Soft Serve Side Probable Cause	Either Side Probable Cause	Remedy	Page Ref.
7. The mix in the hopper is too cold.			a. The hopper temperature is out of adjustment.	a. Contact an authorized service technician.	- - -
8. Mix Low and Mix Out probes are not functioning.			a. Milkstone buildup in the hopper.	a. Clean hoppers thoroughly.	page 6-36
9. Product is collecting on top of the draw valve.	a. Inadequate lubrication of spinner shaft or seal. b. Spinner shaft seal is missing or worn.			a. Lubricate properly. b. Install or replace the spinner shaft seal.	page 6-2 page 6-2
10. Product is collecting on top of the freezer door.			a. The top O-ring on draw valve is improperly lubricated or worn.	a. Lubricate properly or replace the O-ring.	page 6-2 page 6-5
11. Excessive mix leakage from the bottom of door spout.			a. Bottom O-ring on draw valve is improperly lubricated or worn.	a. Lubricate properly or replace the O-ring.	page 6-2 page 6-5
12. Excessive mix leakage into the long drip pan.			a. The driveshaft seal is improperly lubricated or worn. b. The driveshaft seal is installed inside-out on the. c. Inadequate lubrication of the driveshaft. d. The driveshaft and beater assembly work forward. e. Worn rear shell bearing. f. Gear box out of alignment.	a. Lubricate properly or replace the seal. b. Install correctly. c. Lubricate properly. d. Contact an authorized service technician. e. Contact an authorized service technician. f. Contact an authorized service technician.	page 6-1 page 6-4 page 6-1 page 6-4 - - - - - - - - -

Problem	Shake Side Probable Cause	Soft Serve Side Probable Cause	Either Side Probable Cause	Remedy	Page Ref.
13.The driveshaft is stuck in the drive coupling.			<ul style="list-style-type: none"> a. Mix and lubricant collected in drive coupling. b. Rounded corners of driveshaft, drive coupling, or both. c. Gear box is out of alignment. 	<ul style="list-style-type: none"> a. Brush clean the rear shell bearing area regularly. b. Contact an authorized service technician. c. Contact an authorized service technician. 	<p>page 6-36</p> <p>- - -</p> <p>- - -</p>
14.The freezing cylinder walls are scored.	a. Missing or worn front bearing.	<ul style="list-style-type: none"> b. Missing or worn front bearing and beater shoes. c. Broken freezer door baffle rod. 		<ul style="list-style-type: none"> a. Install or replace the front bearing. b. Install or replace the front bearing and beater shoes. c. Replace freezer door. 	<p>page 6-4</p> <p>page 6-5</p> <p>page 6-7</p>
			<ul style="list-style-type: none"> d. Sanitizing solution was still in the freezing cylinder when machine was placed in Auto. 	<ul style="list-style-type: none"> d. Machine must not be placed in Auto mode during sanitizing. Place in Auto mode only after machine has been primed and all sanitizing solution has been removed. 	<p>page 6-15</p> <p>page 6-13</p>
			<ul style="list-style-type: none"> e. Broken beater pins. 	<ul style="list-style-type: none"> e. Replace beater assembly. 	<p>page 6-2</p> <p>page 6-5</p>
		<ul style="list-style-type: none"> f. Beater assembly is bent. g. Gear box is out of alignment. 	<ul style="list-style-type: none"> f. Replace beater assembly. g. Contact an authorized service technician. 	<p>page 6-2</p> <p>page 6-1</p> <p>- - -</p>	

Problem	Shake Side Probable Cause	Soft Serve Side Probable Cause	Either Side Probable Cause	Remedy	Page Ref.
15.The product makes a popping sound when drawn.		a. Draw rate is set too fast.	b. Pump assembled incorrectly. c. Freezing cylinder not primed correctly.	a. Adjust draw rate of 5 oz. to 7-1/2 oz. (142 g to 213 g) of product by weight in 10 seconds. b. Assemble and lubricate according to instructions in this manual. c. Drain the freezing cylinder and reprime the machine.	page 5-3 page 6-8 page 6-14 page 6-15
16.No control panel functions with power switch ON.			a. Machine is unplugged. b. Circuit breaker off or blown fuse.	a. Plug into wall receptacle. b. Turn the breaker on or replace the fuse.	- - - - - -
17.The draw valve is not opening.	a. The power switch is in the OFF position. b. The shake side is in the Standby mode. c. A heat cycle is in progress. d. The menu is displayed, making the flavor select keys inoperative. e. The draw valve wasn't aligned with the actuator bracket when the freezer door was installed. f. The draw valve was not lubricated. g. The shake actuator assembly is out of alignment or is malfunctioning.			a. Place the power switch in the ON position. b. Cancel the Standby mode. c. Wait for the completion of the heat treatment cycle. d. Exit the menu by moving the cursor arrow to EXIT and pressing the Calibration key. This will restore the control keys to their normal function. e. Reassemble with the correct alignment. Tighten the handscrews in a crisscross pattern when installing the freezer door. f. Lubricate the draw valve and O-rings. g. Contact an authorized service technician.	page 5-6 page 5-12 page 5-5 page 6-25 page 6-4 page 6-2 - - -

Problem	Shake Side Probable Cause	Soft Serve Side Probable Cause	Either Side Probable Cause	Remedy	Page Ref.
18.The draw valve is not closing.	<ul style="list-style-type: none"> a. The draw valve was not aligned with the actuator bracket when the freezer door was installed. b. The draw valve was not lubricated. c. The spinner shaft was not lubricated. d. The spinner blade became disengaged from the driven spinner when the draw valve was raised. e. The product is too thick. f. The shake actuator assembly is out of alignment or is malfunctioning. 			<ul style="list-style-type: none"> a. Reassemble with the correct alignment. Tighten the handscrews in a crisscross pattern when installing the freezer door. b. Lubricate the draw valve and O-rings. c. Lubricate the spinner shaft. d. Contact an authorized service technician to check the spinner coupling position on the motor. e. Check that the product temperature is within specification. (See "The product is too thick." on page 8-3.) f. Contact an authorized service technician. 	<ul style="list-style-type: none"> page 6-4 page 6-2 page 6-2 - - - - - - - - -
19.The mix pump will not operate in the Pump mode.			a. Pump motor is not running.	a. Push the pump RESET button.	page 5-3
20.The mix pump runs constantly in the Auto mode.		a. Draw valve is not fully closed.		a. Raise draw handle to close draw valve all the way.	page 6-4 page 6-4

Problem	Shake Side Probable Cause	Soft Serve Side Probable Cause	Either Side Probable Cause	Remedy	Page Ref.
21. Syrup cannot be calibrated or inconsistent calibration readings.	a. The pump tube has collapsed.			a. Replace pump tube.	page 6-37
	b. Syrup temperature too cold.			b. Allow the syrup to warm up before using. Note: <i>Never refrigerate the syrup. Keep a replacement container near the shake machine location so the syrup temperature can stabilize before use.</i>	page 6-26
	c. Thick syrup in bottom of container.			c. Shake well before use.	page 6-26
	d. Syrup leak.			d. Inspect syrup system for leaks.	- - -
	e. Syrup lines are not matched with the syrup flavor or are not properly connected.			e. Match the color of the syrup pickup tube and cap with the correct syrup container. Make sure the tube is properly connected.	page 6-25
	f. Plugged syrup line fitting at freezer door connection.			f. Clean the syrup line fitting.	page 6-26
	g. The pickup tube is pinched or kinked.			g. Adjust the line routing so that it is not pinched or kinked.	page 6-26
	h. The syrup line is plugged or restricted.			h. Flush and sanitize the syrup lines. Clean the syrup system weekly. Do not attach the short syrup line to the door when the line is not primed with syrup.	page 6-38
	i. Air in syrup line.			i. Follow syrup line priming procedure to remove air from line.	page 6-26
	j. Air intake line to pump will not hold syrup prime.			j. Lubricate pump tube fitting O-rings. Inspect the intake line for leaks.	page 6-38

Problem	Shake Side Probable Cause	Soft Serve Side Probable Cause	Either Side Probable Cause	Remedy	Page Ref.
22.Syrup continues to flow after drawing a shake.	a. Air in syrup line. b. Duckbill valve damaged.			a. Follow syrup prime procedure. b. Remove syrup nose fitting and clean. Replace duckbill valve.	page 6-26 page 6-39
23.Spinner shaft will not rotate to blend mix and syrup.	a. Flexible coupling is broken. b. Pin is missing in quick disconnect of spinner coupling. c. Spinner motor is out on thermal overload.			a. Contact an authorized service technician. b. Contact an authorized service technician. c. Allow the spinner motor to cool. Check lubrication on the spinner shaft.	- - - - - - page 6-2
24.Syrup toppings are not hot.		a. Topping heaters are not ON. b. No water is in topping well. c. The water is not hot enough.		a. Select topping heater keys. keys will be lit when heaters are ON. b. Fill to indicating mark. c. Using a thermometer, check the water temperature in the topping well. It should be 140°F (60°C).	page 6-20 page 6-20 - - -

Section 9

Parts Replacement Schedule

Table 9-1

Part Description	Every 3 Months	Every 6 Months	Annually
Scraper Blade-Shake		X	
Scraper Blade-Soft Serve	X		
Drive Shaft Seal	X		
Freezer Door O-Ring-Shake	X		
Freezer Door Gasket-Soft Serve	X		
Front Bearing	X		
Front Beater Shoes-Soft Serve	X		
Draw Valve O-Ring	X		
Spinner Shaft Seal-Shake	X		
Restrictor Cap-Shake	X		
Mix Feed Tube O-Ring	X		
Pump O-Ring	X		
Pump Valve Gasket	X		
Mix Feed Tube Check Ring	X		
Pump Drive Shaft O-Ring	X		
Syrup Valve-Duckbill	X		
Peristaltic Pump Tubes		Inspect and replace if necessary.	
White Bristle Brush, 3" x 7"		Inspect and replace if necessary.	Minimum
White Bristle Brush, 3" x 1/2"		Inspect and replace if necessary.	Minimum
White Bristle Brush, 1-1/2" x 3"		Inspect and replace if necessary.	Minimum
White Bristle Brush, 1" x 2"		Inspect and replace if necessary.	Minimum
Black Bristle Brush, 1" x 2"		Inspect and replace if necessary.	Minimum
Double-Ended Brush		Inspect and replace if necessary.	Minimum
Yellow Bristle Brush		Inspect and replace if necessary.	Minimum
Brush Set (3)		Inspect and replace if necessary.	Minimum
Baffle-Threadless Molded		Inspect and replace if necessary.	

TAYLOR COMPANY LIMITED WARRANTY ON FREEZERS

Taylor Company is pleased to provide this limited warranty on new Taylor-branded machines available from Taylor (the “Product”) to the original purchaser only.

LIMITED WARRANTY

Taylor warrants the Product against failure due to defect in materials or workmanship under normal use and service as follows. All warranty periods begin on the date of original Product installation. If a part fails due to defect during the applicable warranty period, Taylor, through an authorized Taylor distributor or service agency, will provide a new or remanufactured part, at Taylor’s option, to replace the failed defective part at no charge for the part. Except as otherwise stated herein, these are Taylor’s exclusive obligations under this limited warranty for a Product failure. This limited warranty is subject to all provisions, conditions, limitations, and exclusions listed below and on the reverse (if any) of this document.

Table 10-1

Product	Part	Limited Warranty Period
Soft Serve	Insulated shell assembly	Five (5) years
Frozen Yogurt Shakes	Refrigeration compressor (except service valve)	Five (5) years
Smoothies	Beater motors	Two (2) years
Frozen Beverage	Beater drive gear	Two (2) years
Batch Desserts	Printed circuit boards and Softech controls beginning with serial number H8024200	Two (2) years
	Parts not otherwise listed in this table or excluded below	One (1) year

LIMITED WARRANTY CONDITIONS

1. If the date of original installation of the Product cannot be verified, then the limited warranty period begins ninety (90) days from the date of Product manufacture (as indicated by the Product serial number). Proof of purchase may be required at time of service.
2. This limited warranty is valid only if the Product is installed and all required service work on the Product is performed by an authorized Taylor distributor or service agency, and only if genuine, new Taylor parts are used.
3. Installation, use, care, and maintenance must be normal and in accordance with all instructions contained in the Taylor Operator’s Manual.
4. Defective parts must be returned to the authorized Taylor distributor or service agency for credit.
5. The use of any refrigerant other than that specified on the Product’s data label will void this limited warranty.

LIMITED WARRANTY EXCEPTIONS

This limited warranty does **not** cover:

1. Labor or other costs incurred for diagnosing, repairing, removing, installing, shipping, servicing, or handling of defective parts, replacement parts, or new products.
2. Normal maintenance, cleaning, and lubrication as outlined in the Taylor Operator's Manual, including cleaning of condensers.
3. Replacement of wear items designated as Class "000" parts in the Taylor Operator's Manual.
4. External hoses, electrical power supplies, and machine grounding.
5. Parts not supplied or designated by Taylor, or damages resulting from their use.
6. Return trips or waiting time required because a service technician is prevented from beginning warranty service work promptly upon arrival.
7. Failure, damage, or repairs due to faulty installation, misapplication, abuse, no or improper servicing, unauthorized alteration, or improper operation or use as indicated in the Taylor Operator's Manual, including but not limited to the failure to use proper assembly and cleaning techniques, tools, or approved cleaning supplies.
8. Failure, damage, or repairs due to theft, vandalism, wind, rain, flood, high water, water, lightning, earthquake, or any other natural disaster, fire, corrosive environments, insect or rodent infestation, or other casualty, accident, or condition beyond the reasonable control of Taylor; operation above or below the electrical or water supply specification of the Product; or components repaired or altered in any way so as, in the judgment of the Manufacturer, to adversely affect performance, or normal wear or deterioration.
9. Any Product purchased over the Internet.
10. Failure to start due to voltage conditions, blown fuses, open circuit breakers, or damages due to the inadequacy or interruption of electrical service.
11. Electricity or fuel costs, or increases in electricity or fuel costs from any reason whatsoever.
12. Damages resulting from the use of any refrigerant other than that specified on the Product's data label will void this limited warranty.
13. Any cost to replace, refill, or dispose of refrigerant, including the cost of refrigerant.
14. **ANY SPECIAL, INDIRECT, OR CONSEQUENTIAL PROPERTY OR COMMERCIAL DAMAGE OF ANY NATURE WHATSOEVER.** Some jurisdictions do not allow the exclusion of incidental or consequential damages, so this limitation may not apply to you.

This limited warranty gives you specific legal rights, and you may also have other rights which vary from jurisdiction to jurisdiction.

LIMITATION OF WARRANTY

THIS LIMITED WARRANTY IS EXCLUSIVE AND IS IN LIEU OF ALL OTHER WARRANTIES, CONDITIONS, AND/OR REMEDIES UNDER THE LAW, INCLUDING ANY IMPLIED WARRANTIES OR CONDITIONS OF MERCHANTABILITY OR FITNESS FOR A PARTICULAR PURPOSE. THE ORIGINAL OWNER'S SOLE REMEDY WITH RESPECT TO ANY PRODUCTS SHALL BE REPAIR OR REPLACEMENT OF DEFECTIVE COMPONENTS UNDER THE TERMS OF THIS LIMITED WARRANTY. ALL RIGHTS TO CONSEQUENTIAL OR INCIDENTAL DAMAGES (INCLUDING CLAIMS FOR LOST SALES, LOST PROFITS, PRODUCT LOSS, PROPERTY DAMAGES, OR SERVICE EXPENSES) ARE EXPRESSLY EXCLUDED. THE EXPRESS WARRANTIES MADE IN THIS LIMITED WARRANTY MAY NOT BE ALTERED, ENLARGED, OR CHANGED BY ANY DISTRIBUTOR, DEALER, OR OTHER PERSON, WHATSOEVER.

LEGAL REMEDIES

The owner **must** notify Taylor in writing, by certified or registered letter to the following address, of any defect or complaint with the Product, stating the defect or complaint and a specific request for repair, replacement, or other correction of the Product under warranty, mailed at least thirty (30) days before pursuing any legal rights or remedies.

Taylor Company
750 N. Blackhawk Blvd.
Rockton, IL 61072, U.S.A.

TAYLOR COMPANY LIMITED WARRANTY ON TAYLOR GENUINE PARTS

Taylor Company is pleased to provide this limited warranty on new Taylor genuine replacement components and parts available from Taylor (the "Parts") to the original purchaser only.

LIMITED WARRANTY

Taylor warrants the Parts against failure due to defect in materials or workmanship under normal use and service as follows. All warranty periods begin on the date of original installation of the Part in the Taylor machine. If a Part fails due to defect during the applicable warranty period, Taylor, through an authorized Taylor distributor or service agency, will provide a new or remanufactured Part, at Taylor's option, to replace the failed defective Part at no charge for the Part. Except as otherwise stated herein, these are Taylor's exclusive obligations under this limited warranty for a Part failure. This limited warranty is subject to all provisions, conditions, limitations, and exclusions listed below and on the reverse (if any) of this document.

Table 11-1

Part's Warranty Class Code or Part	Limited Warranty Period
Class 103 Parts ¹	Three (3) months
Class 212 Parts ²	Twelve (12) months
Class 512 Parts	Twelve (12) months
Class 000 Parts	No warranty

LIMITED WARRANTY CONDITIONS

1. If the date of original installation of the Part cannot be otherwise verified, proof of purchase may be required at time of service.
2. This limited warranty is valid only if the Part is installed and all required service work in connection with the Part is performed by an authorized Taylor distributor or service agency.
3. The limited warranty applies only to Parts remaining in use by their original owner at their original installation location in the machine of original installation.
4. Installation, use, care, and maintenance must be normal and in accordance with all instructions contained in the Taylor Operator's Manual.
5. Defective Parts must be returned to the authorized Taylor distributor or service agency for credit.
6. This warranty is not intended to shorten the length of any warranty coverage provided pursuant to a separate Taylor Limited Warranty on freezer or grill machine.
7. The use of any refrigerant other than that specified for the machine in which the Part is installed will void this limited warranty.

^{1, 2} Except that Taylor Part #032129SER2 (Compressor-Air-230V SERV) and Taylor Part #075506SER1 (Compressor-Air-115V 60HZ) shall have a limited warranty period of twelve (12) months when used in Taylor freezer machines and a limited warranty period of two (2) years when used in Taylor grill machines.

LIMITED WARRANTY ON PARTS

LIMITED WARRANTY EXCEPTIONS

This limited warranty does **not** cover:

1. Labor or other costs incurred for diagnosing, repairing, removing, installing, shipping, servicing, or handling of defective Parts, replacement Parts, or new Parts.
2. Normal maintenance, cleaning, and lubrication as outlined in the Taylor Operator's Manual, including cleaning of condensers or carbon and grease buildup.
3. Required service, whether cleaning or general repairs, to return the cooking surface assemblies, including the upper platen and lower plate, to an operational condition to achieve proper cooking or allow proper assembly of release sheets and clips as a result of grease buildup on the cooking surfaces, including but not limited to the platen and plate, sides of the shroud, or top of the shroud.
4. Replacement of cooking surfaces, including the upper platen and lower plate, due to pitting or corrosion (or in the case of the upper platen, due to loss of plating) as a result of damage due to the impact of spatulas or other small wares used during the cooking process or as a result of the use of cleaners, cleaning materials, or cleaning processes not approved for use by Taylor.
5. Replacement of wear items designated as Class "000" Parts in the Taylor Operator's Manual, as well as any release sheets and clips for the Product's upper platen assembly.
6. External hoses, electrical power supplies, and machine grounding.
7. Parts not supplied or designated by Taylor, or damages resulting from their use.
8. Return trips or waiting time required because a service technician is prevented from beginning warranty service work promptly upon arrival.
9. Failure, damage, or repairs due to faulty installation, misapplication, abuse, no or improper servicing, unauthorized alteration, or improper operation or use as indicated in the Taylor Operator's Manual, including but not limited to the failure to use proper assembly and cleaning techniques, tools, or approved cleaning supplies.
10. Failure, damage, or repairs due to theft, vandalism, wind, rain, flood, high water, water, lightning, earthquake, or any other natural disaster, fire, corrosive environments, insect or rodent infestation, or other casualty, accident, or condition beyond the reasonable control of Taylor; operation above or below the gas, electrical, or water supply specification of the machine in which a part is installed; or Parts or the machines in which they are installed repaired or altered in any way so as, in the judgment of Taylor, to adversely affect performance, or normal wear or deterioration.
11. Any Part purchased over the Internet.
12. Failure to start due to voltage conditions, blown fuses, open circuit breakers, or damages due to the inadequacy or interruption of electrical service.
13. Electricity, gas, or other fuel costs, or increases in electricity or fuel costs from any reason whatsoever.
14. Damages resulting from the use of any refrigerant other than that specified for the machine in which the Part is installed will void this limited warranty.
15. Any cost to replace, refill, or dispose of refrigerant, including the cost of refrigerant.
16. **ANY SPECIAL, INDIRECT, OR CONSEQUENTIAL PROPERTY OR COMMERCIAL DAMAGE OF ANY NATURE WHATSOEVER.** Some jurisdictions do not allow the exclusion of incidental or consequential damages, so this limitation may not apply to you.

This limited warranty gives you specific legal rights, and you may also have other rights which vary from jurisdiction to jurisdiction.

LIMITATION OF WARRANTY

THIS LIMITED WARRANTY IS EXCLUSIVE AND IS IN LIEU OF ALL OTHER WARRANTIES, CONDITIONS, AND/OR REMEDIES UNDER THE LAW, INCLUDING ANY IMPLIED WARRANTIES OR CONDITIONS OF MERCHANTABILITY OR FITNESS FOR A PARTICULAR PURPOSE. THE ORIGINAL OWNER'S SOLE REMEDY WITH RESPECT TO ANY PRODUCTS SHALL BE REPAIR OR REPLACEMENT OF DEFECTIVE PARTS UNDER THE TERMS OF THIS LIMITED WARRANTY. ALL RIGHTS TO CONSEQUENTIAL OR INCIDENTAL DAMAGES (INCLUDING CLAIMS FOR LOST SALES, LOST PROFITS, PRODUCT LOSS, PROPERTY DAMAGES, OR SERVICE EXPENSES) ARE EXPRESSLY EXCLUDED. THE EXPRESS WARRANTIES MADE IN THIS LIMITED WARRANTY MAY NOT BE ALTERED, ENLARGED, OR CHANGED BY ANY DISTRIBUTOR, DEALER, OR OTHER PERSON, WHATSOEVER.

LEGAL REMEDIES

The owner **must** notify Taylor in writing, by certified or registered letter to the following address, of any defect or complaint with the Part, stating the defect or complaint and a specific request for repair, replacement, or other correction of the Part under warranty, mailed at least thirty (30) days before pursuing any legal rights or remedies.

Taylor Company
750 N. Blackhawk Blvd.
Rockton, IL 61072, U.S.A.

