

# OPERATOR'S MANUAL



## Model C708 & C716 Heat Treatment Soft Serve Freezers

Original Operating Instructions

059061-M

January 2005 (Original Publication)  
(Updated 7/28/2020)



## Section 1: To the Installer

Installer Safety . . . . .	1-1
Site Preparation . . . . .	1-1
Air-Cooled Machines . . . . .	1-2
Water Connections . . . . .	1-2
Electrical Connections . . . . .	1-2
Beater Rotation . . . . .	1-3
Refrigerant . . . . .	1-3

## Section 2: To the Operator

Compressor Warranty Disclaimer . . . . .	2-2
--	-----

## Section 3: Safety

## Section 4: Operator Parts Identification

Model C708 Exploded View . . . . .	4-1
Model C716 Exploded View . . . . .	4-3
Model C708 Single Spout Door and Beater Assembly . . . . .	4-5
Model C716 Door and Beater Assembly . . . . .	4-6
X57029-XX Pump A. - Mix Simplified (Models C708 & C716) . . . . .	4-7
Accessories . . . . .	4-8
Brush A.-Package-HT <a href="#">X44127</a> . . . . .	4-9

## Section 5: User Interface

Symbol Definitions . . . . .	5-2
Power Switch . . . . .	5-2
Fluorescent Display . . . . .	5-2
Indicator Lights . . . . .	5-2
Reset Mechanism . . . . .	5-2
Air/Mix Pump Reset Mechanism . . . . .	5-3
Adjustable Draw Handle . . . . .	5-3
Operating Screen Descriptions . . . . .	5-3
Power Up Memory (Initializing) . . . . .	5-3
Language Initialization . . . . .	5-3
System Data . . . . .	5-4
Heat Cycle . . . . .	5-5
Freezer Locks . . . . .	5-5
Manager's Menu . . . . .	5-7

# Table of Contents

---

## **Section 6: Operating Procedures**

Freezing Cylinder Assembly . . . . .	6-1
Freezer Door Assembly . . . . .	6-3
Mix Pump Assembly . . . . .	6-6
Sanitizing . . . . .	6-9
Priming . . . . .	6-10
Daily Closing Procedures . . . . .	6-11
Daily Opening Procedures . . . . .	6-12
Manual Brush-Cleaning . . . . .	6-13

## **Section 7: Operator Checklist**

During Cleaning and Sanitizing . . . . .	7-1
Troubleshooting Bacterial Count . . . . .	7-1
Regular Maintenance Checks. . . . .	7-1
Winter Storage . . . . .	7-2

## **Section 8: Troubleshooting Guide**

## **Section 9: Parts Replacement Schedule**

## **Section 10: Limited Warranty on Equipment**

## **Section 11: Limited Warranty on Parts**

The following information has been included in the manual as safety and regulatory guidelines. For complete installation instructions, please see the Installation Checklist.

## Installer Safety



**IMPORTANT!** In all areas of the world, the machine should be installed in accordance with existing local codes. Please contact your local authorities if you have any questions.

Care should be taken to ensure that all basic safety practices are followed during the installation and servicing activities related to the installation and service of Taylor machines.

- Only authorized Taylor service personnel should perform installation and repairs on the machine.
- Authorized service personnel should consult OSHA Standard 29CFR1910.147 or the applicable code of the local area for the industry standards on lockout/tagout procedures before beginning any installation or repairs.
- Authorized service personnel must ensure that the proper personal protective equipment (PPE) is available and worn when required during installation and service.
- Authorized service personnel must remove all metal jewelry, rings, and watches before working on electrical equipment.



**DANGER!** The main power supply(s) to the machine must be disconnected prior to performing any repairs. Failure to follow this instruction may result in personal injury or death from electrical shock or hazardous moving parts, as well as poor performance or damage to the machine.

**Note:** All repairs must be performed by an authorized Taylor service technician.



**WARNING!** This machine has many sharp edges that can cause severe injuries.

## Site Preparation

Review the area where the machine will be installed before uncrating the machine. Make sure that all possible hazards to the user and the machine have been addressed.

**For Indoor Use Only:** This machine is designed to operate indoors, under normal ambient temperatures of 70°F to 75°F (21°C to 24°C). The freezer has successfully performed in high ambient temperatures of 104°F (40°C) at reduced capacities.



**WARNING!** This machine must **NOT** be installed in an area where a water jet or hose can be used. Never use a water jet or hose to rinse or clean this machine. Using a water jet or hose on or around this machine may result in the electrocution of the user or damage to the machine.



**WARNING!** Only install this machine in a location where its use and maintenance is restricted to trained personnel. Failure to comply may result in personal injury.



**CAUTION!** This machine must be installed on a level surface to avoid the hazard of tipping. Extreme care should be taken in moving this machine for any reason. Two or more persons are required to safely move this machine. Failure to comply may result in personal injury or machine damage.

Uncrate the machine and inspect it for damage. Report any damage to your Taylor distributor.

This machine is made in the USA and has USA sizes of hardware. All metric conversions are approximate and vary in size.

### 1 Air-Cooled Machines

**Do not** obstruct air intake and discharge openings:

**Model C708:** Requires a minimum of 6 in. (152 mm) of clearance on both sides and 0 in. in the rear of the machine.

**Model C716:** Requires a minimum of 3 in. (76 mm) of clearance on all sides. Install the deflector provided to prevent recirculation of warm air.

This will allow for adequate air flow across the condensers. Failure to allow adequate clearance can reduce the refrigeration capacity of the freezers and possibly cause permanent damage to the compressors.

### Water Connections

#### (Water-Cooled Machines Only)

An adequate cold water supply must be provided with a hand shutoff valve. On the underside of the base pan or on the right side, two 3/8 in. (9.5 mm) I.P.S. water connections for inlet and outlet are provided for easy hook-up. Permanently connect machine using 1/2 in. (12.7 mm) inside diameter water lines. (Flexible lines are recommended, if local codes permit.) Depending on local water conditions, it may be advisable to install a water strainer to prevent foreign substances from clogging the automatic water valve. There will be only one water in and one water out connection.

**Do not** install a hand shutoff valve on the water out line. Water should always flow in this order: first, through the automatic water valve; second, through the condenser; and third, through the outlet fitting to an open trap drain.



**IMPORTANT!** A backflow prevention device is required on the incoming water connection side. Please see the applicable national, state, and local codes for determining the proper configuration. Water pressure to the unit must not exceed 150 psi (1034 kPa).

### Electrical Connections



**IMPORTANT!** In the United States, this machine is intended to be installed in accordance with the National Electrical Code (NEC), ANSI/NFPA 701987. The purpose of the NEC code is the practical safeguarding of persons and property from hazards arising from the use of electricity. This code contains provisions considered necessary for safety.

In all other areas of the world, the machine should be installed in accordance with the existing local codes. Please contact your local authorities if you have any questions.

Each machine requires one power supply for each data label on the machine. Check the data label(s) on the machine for branch circuit overcurrent protection or fuse, circuit ampacity and other electrical specifications.

Refer to the wiring diagram provided inside of the electrical box for proper power connections.



**FOLLOW YOUR LOCAL ELECTRICAL CODES.**



**WARNING!** This machine must be properly grounded! Failure to do so can result in severe personal injury from electrical shock!



**IMPORTANT!** This machine is provided with an equipotential grounding lug that is to be properly attached to the rear of the frame by the authorized installer. The installation location is marked by the equipotential bonding symbol (5021 of IEC 60417-1) on the removable panel and the frame.



**NOTICE!**

- Stationary machines which are not equipped with a power cord and a plug or another device to disconnect the machine from the power source must have an all-pole disconnecting device with a contact gap of at least 0.125 in. (3 mm) installed in the external installation.

- Machines that are permanently connected to fixed wiring and for which leakage currents may exceed 10 mA, particularly when disconnected or not used for long periods, or during initial installation, shall have protective devices to protect against the leakage of current, such as a GFI, installed by the authorized personnel to the local codes.
- Supply cords used with this machine shall be oil-resistant, sheathed flexible cable not lighter than ordinary polychloroprene or other equivalent synthetic elastomer-sheathed cord (code designation 60245 IEC 57) installed with the proper cord anchorage to relieve conductors from strain, including twisting, at the terminals and protect the insulation of the conductors from abrasion.
- If the supply cord is damaged, it must be replaced by the manufacturer, service agent, or a similarly qualified person, in order to avoid a hazard.
- Secure the supply cord ground lead to the machine in a location where if the cord is pulled, the main power leads will become taut before the ground lead can break loose.

## Beater Rotation



**NOTICE!** Beater rotation must be clockwise as viewed looking into the freezing cylinder.

**Note:** *The following procedures must be performed by an authorized Taylor service technician.*

To correct rotation on a three-phase unit, interchange any two incoming power supply lines at freezer main terminal block only.

To correct rotation on a single-phase unit, change the leads inside the beater motor. (Follow the diagram printed on the motor.)

Electrical connections are made directly to the terminal block provided in the main control box, located:

C708 - behind the rear panel.

C716 - behind the lower front panel.

## Refrigerant



**CAUTION!** This machine contains fluorinated greenhouse gases (F-Gas) to provide refrigeration using a hermetically sealed circuit or within foam insulation. This machine's type of gas, quantity, Global Warming Potential (GWP), and CO<sub>2</sub> tonnes equivalent information is recorded on the unit's data-label. The refrigerant used is generally considered non-toxic and non-flammable. However any gas under pressure is potentially hazardous and must be handled with caution.

**NEVER** fill any refrigerant cylinder completely with liquid. Filling the cylinder to approximately 80% will allow for normal expansion.



**CAUTION!** Use only approved refrigerant listed on the machine's data-label or authorized through a manufacturer's technical bulletin. The use of any other refrigerant may expose users and operators to unexpected safety hazards.



**WARNING!** Refrigerant liquid sprayed onto the skin may cause serious damage to tissue. Keep eyes and skin protected. If refrigerant burns should occur, flush the area immediately with cold water. If burns are severe, apply ice packs and contact a physician immediately.



**NOTICE!** Taylor reminds technicians to be aware of government laws regarding refrigerant recovery, recycling, and reclaiming systems. If you have any questions regarding these laws, please contact the factory service department.



**IMPORTANT!** *Refrigerants and their associated lubricants may be extremely moisture absorbent. When opening a refrigeration system, the maximum time the system is open must not exceed 15 minutes. Cap all open tubing to prevent humid air or water from being absorbed by the oil.*



Your freezers have been carefully engineered and manufactured to give you dependable operation. These machines, when properly operated and cared for, will produce a consistent quality product. Like all mechanical products, they will require cleaning and maintenance. A minimum amount of care and attention is necessary if the operating procedures outlined in this manual are followed closely.



**IMPORTANT!** This manual should be read before operating or performing any maintenance on your machine.

Your Taylor freezer will **not** eventually compensate for and correct any errors during the setup or filling operations. Thus, the initial assembly and priming procedures are of extreme importance. It is strongly recommended that personnel responsible for the machine's operation, both assembly and disassembly, sit down together and go through these procedures in order to be properly trained and to make sure that no misunderstandings exist.

In the event you should require technical assistance, please contact your local authorized Taylor distributor.

**Note:** Your Taylor warranty is valid only if the parts are authorized Taylor parts, purchased from the local authorized Taylor distributor, and only if all required service work is provided by an authorized Taylor service technician. Taylor reserves the right to deny warranty claims on units or parts if unapproved parts or incorrect refrigerant were installed in the unit, system modifications were performed beyond factory recommendations, or it is determined that the failure was caused by abuse, misuse, neglect, or failure to follow all operating instructions. For full details of your Taylor warranty, please see the Limited Warranty section in this manual.

**Note:** Constant research results in steady improvements; therefore, information in this manual is subject to change without notice.



**IMPORTANT!** If the crossed-out waste container symbol is affixed to this product, it signifies that this product is compliant with the EU Directive as well as other similar legislation in effect after August 13, 2005. Therefore, it must be collected separately after its use is completed, and cannot be disposed as unsorted municipal waste.

The user is responsible for delivering the product to the appropriate collection facility, as specified by your local code.

For additional information regarding applicable local laws, please contact the municipal facility and/or local distributor.

### Compressor Warranty Disclaimer

The refrigeration compressor(s) on this unit are warranted for the term stated in the Limited Warranty section in this manual. However, due to the Montreal Protocol and the U.S. Clean Air Act Amendments of 1990, many new refrigerants are being tested and developed, thus seeking their way into the service industry. Some of these new refrigerants are being advertised as drop-in replacements for numerous applications. It should be noted that in the event of ordinary service to this unit's refrigeration system, **only the refrigerant specified on the affixed data label should be used.** The unauthorized use of alternate refrigerants will void your Taylor compressor warranty. It is the unit owner's responsibility to make this fact known to any technician he/she employs.

It should also be noted that Taylor does not warrant the refrigerant used in its equipment. For example, if the refrigerant is lost during the course of ordinary service to this machine, Taylor has no obligation to either supply or provide its replacement either at billable or unbillable terms. Taylor does have the obligation to recommend a suitable replacement if the original refrigerant is banned, obsolete, or no longer available during the 5-year warranty of the compressor.

Taylor will continue to monitor the industry and test new alternates as they are being developed. Should a new alternate prove, through our testing, that it would be accepted as a drop-in replacement, then the above disclaimer would become null and void. To find out the current status of an alternate refrigerant as it relates to your compressor warranty, call the local Taylor distributor or the Taylor factory. Be prepared to provide the model/serial number of the unit in question.

### For Units Equipped with Taylor's Remote Monitoring System

#### FCC / IC ID Label Placement:

- This hardware installation package includes a label that must be placed on the unit immediately after the installation of the IoT hardware device has been completed.
- The label indicates the FCC ID and Industry Canada ID for the wireless communication device. The label must be placed on the outside surface of the machine, in a manner that is visible and unobstructed.
- It is recommended that this label be placed directly adjacent to the product nameplate of this device.

#### FCC Compliance Statement:

- This equipment has been tested and found to comply with the limits for a Class A digital device, pursuant to part 15 of the FCC Rules.
- These limits are designed to provide reasonable protection against harmful interference when the equipment is operated in a commercial environment.
- This equipment generates, uses, and can radiate radio frequency energy, and if not installed and used in accordance with the instruction manual, may cause harmful interference to radio communications.
- Operation of this equipment in a residential area is likely to cause harmful interference, in which case the user will be required to correct the interference at his own expense.

#### Industry Canada Statement:

- This device complies with Industry Canada license-exempt RSS standard(s).
- Operation is subject to the following two conditions:
  - a. This device may not cause interference.
  - b. This device must accept any interference, including interference that may cause undesired operation of this device.

We at Taylor Company are concerned about the safety of the operator when he or she comes in contact with the freezer and its parts. Taylor has gone to extreme efforts to design and manufacture built-in safety features to protect both you and the service technician. As an example, warning labels have been attached to the freezer to further point out safety precautions to the operator.



**DANGER!** Failure to adhere to the following safety precautions may result in severe personal injury or death. Failure to comply with these warnings may also damage the machine and/or its components. Such damage may require component replacement and service repair expenses.



**NOTICE! DO NOT** operate the machine without reading the Operator Manual. Failure to follow this instruction may result in machine damage, poor machine performance, health hazards, or personal injury.



**IMPORTANT!** *This machine is to be used only by trained personnel. It is not intended for use, cleaning, or maintenance by children or people with reduced physical, sensory, or mental capabilities, or lack of experience and knowledge, unless given supervision or instruction concerning the use of the machine by a person responsible for their safety. Children should be supervised to ensure that they do not play with the machine.*



**IMPORTANT!** *This machine is provided with an equipotential grounding lug that is to be properly attached to the rear of the frame by the authorized installer. The installation location is marked by the equipotential bonding symbol (5021 of IEC 60417-1) on the removable panel and the frame.*



**WARNING! DO NOT** use a water jet to clean or rinse the machine. Failure to follow these instructions may result in serious electrical shock.



**WARNING!** Avoid injury.

- **DO NOT** operate the machine unless it is properly grounded.
- **DO NOT** operate machine with larger fuses than specified on the data label.
- All repairs must be performed by an authorized Taylor service technician.
- The main power supplies to machine must be disconnected prior to performing repairs.
- **For Cord-Connected Machines:** Only authorized Taylor service technicians or licensed electricians may install a plug or replacement cord on the machine.
- Stationary machine which are not equipped with a power cord and a plug or another device to disconnect the machine from the power source must have an all-pole disconnecting device with a contact gap of at least 0.125 in. (3 mm) installed in the external installation.
- Machines that are permanently connected to fixed wiring and for which leakage currents may exceed 10 mA, particularly when disconnected or not used for long periods, or during initial installation, shall have protective devices to protect against the leakage of current, such as a GFI, installed by the authorized personnel to the local codes.
- Supply cords used with this machine shall be oil-resistant, sheathed flexible cable not lighter than ordinary polychloroprene or other equivalent synthetic elastomer-sheathed cord (code designation 60245 IEC 57) installed with the proper cord anchorage to relieve conductors from strain, including twisting, at the terminals and protect the insulation of the conductors

from abrasion.

- If the supply cord is damaged, it must be replaced by the manufacturer, service agent, or a similarly qualified person, in order to avoid a hazard.
- Secure the supply cord ground lead to the machine in a location where if the cord is pulled, the main power leads will become taut before the ground lead can break loose.



**WARNING!** Avoid injury.

- **DO NOT** allow untrained personnel to operate this machine.
- **DO NOT** operate the machine unless all service panels and access doors are restrained with screws.
- **DO NOT** remove any internal operating parts (examples: machine door, beater, scraper blades, etc.) unless all control switches are in the OFF position.

Failure to follow these instructions may result in severe personal injury, especially to fingers or hands, from hazardous moving parts.



**WARNING!** This machine has many sharp edges that can cause severe injuries.

- **DO NOT** put objects or fingers in the door spout. This may contaminate the product and cause severe personal injury from blade contact.
- **Use extreme caution** when removing the beater assembly. The scraper blades are very sharp.
- **Handling Sharp Edges:** Two people are required to handle the cup/cone dispenser. Protective gloves must be worn and the mounting holes must NOT be used to lift or hold the dispenser. Failure to follow this instruction can result in personal injury to fingers or equipment damage.



**IMPORTANT!** Access to the service area of the machine is restricted to persons having knowledge and practical experience with the machine, in particular as far as safety and hygiene are concerned.



**CAUTION!** This machine must be placed on a level surface. Failure to comply may result in personal injury or machine damage.



**NOTICE!** Cleaning and sanitizing schedules are governed by your federal, state, or local regulatory agencies and must be followed accordingly. Please see the cleaning section of this manual for the proper procedure to clean this machine.



**CAUTION!** This machine is designed to maintain product temperature under 41°F (5°C). Any product being added to this machine must be below 41°F (5°C). Failure to follow this instruction may result in health hazards and poor machine performance.

**Do not** run the machine without product. Failure to follow this instruction can result in damage to the machine.

**Do not** obstruct air intake and discharge openings:

**C708:** A minimum of 6 in. (152 mm) airspace is required on both sides and 0 in. (0 mm) on the rear.

**C716:** A minimum of 3 in. (76 mm) airspace is required on all sides. Install the deflector provided to prevent recirculation of warm air.

Failure to follow these instructions may cause poor freezer performance and damage to the machines.

**For Indoor Use Only:** This machine is designed to operate indoors under normal ambient temperatures of 70°F to 75°F (21°C to 24°C). The machine has successfully performed in high ambient temperatures of up to 104°F (40°C) at reduced capacities.

**Noise Level:** Airborne noise emission does not exceed 78 dB(A) when measured at a distance of 39 in. (1.0 m) from the surface of the machine and at a height of 62 in.

(1.6 m) from the floor.



## Model C708 Exploded View

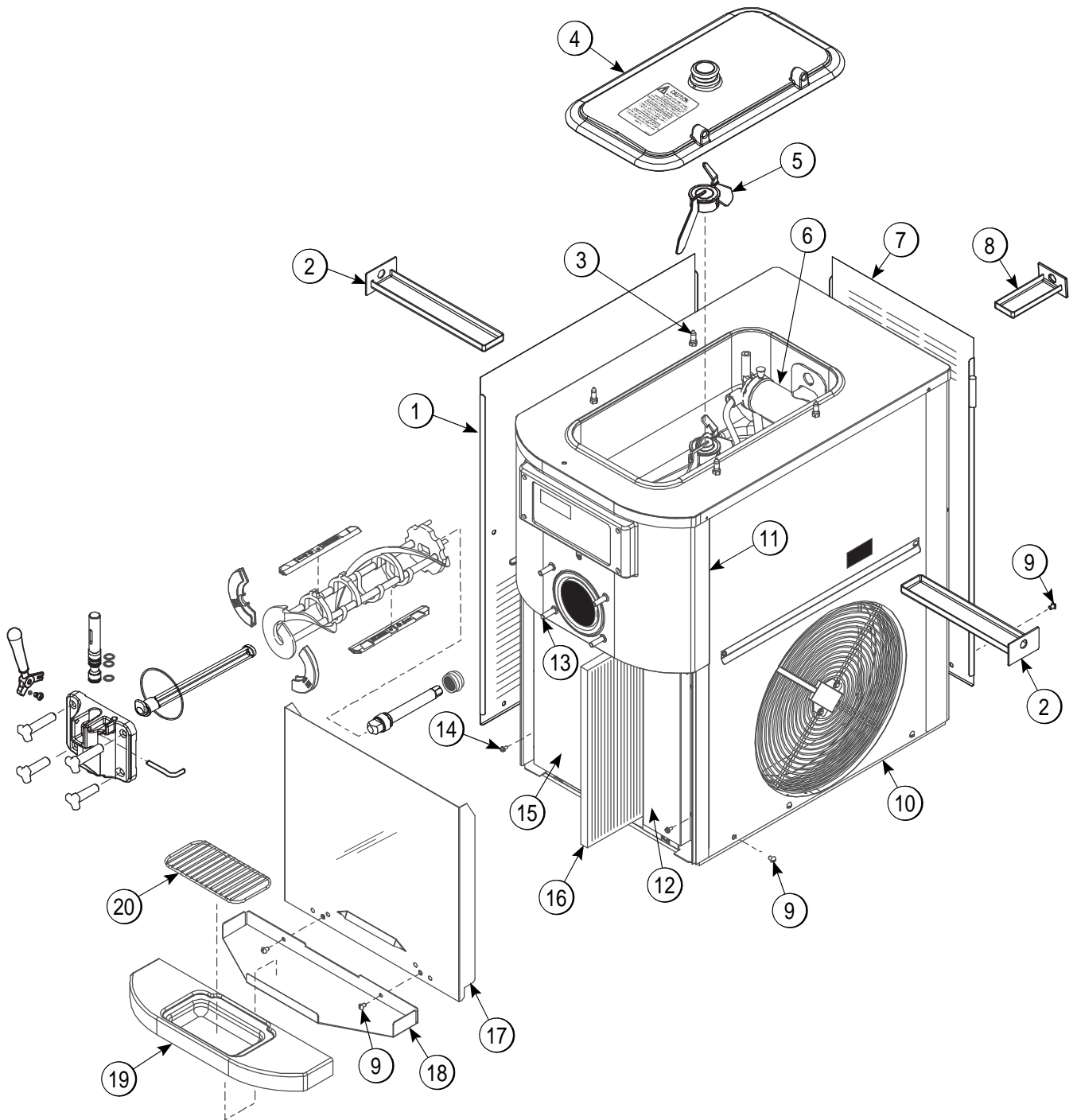

4

Figure 4-1

## OPERATOR PARTS IDENTIFICATION

### Model C708 Exploded View Parts Identification

Item	Description	Part No.
1	Panel-Side-Left	056963
2	Pan-drip 11-5/8 Long	027503
3	Pin-Retaining-Hopper CVR	043934
4	Kit A.-Cover-Hopper	X65368
5	Blade A.-Agitator	X56591
6	Pump A.-Mix Simplified S.S.	X57029-14
7	Panel-Rear	056077
8	Pan A.-Drip 5 1/2" Long	X56074
9	Screw-1/4-20x3/8 RHM-STNLS	011694
10	Panel A-Side-Right	X57871

Item	Description	Part No.
11	Panel A.-Front-Upper	X59423
12	Cover-Access-Front R.	056933
13	Stud-Nose Cone	055987
14	Screw 10 X 3/8 Slotted	015582
15	Cover-Access-Left	056946
16	Filter-Air	052779-9
17	Panel A.-Front-Lower	X58955
18	Shelf-Tray-Drip	056076
19	Tray-Drip	056858
20	Shield-Splash	049203

4

Model C716 Exploded View

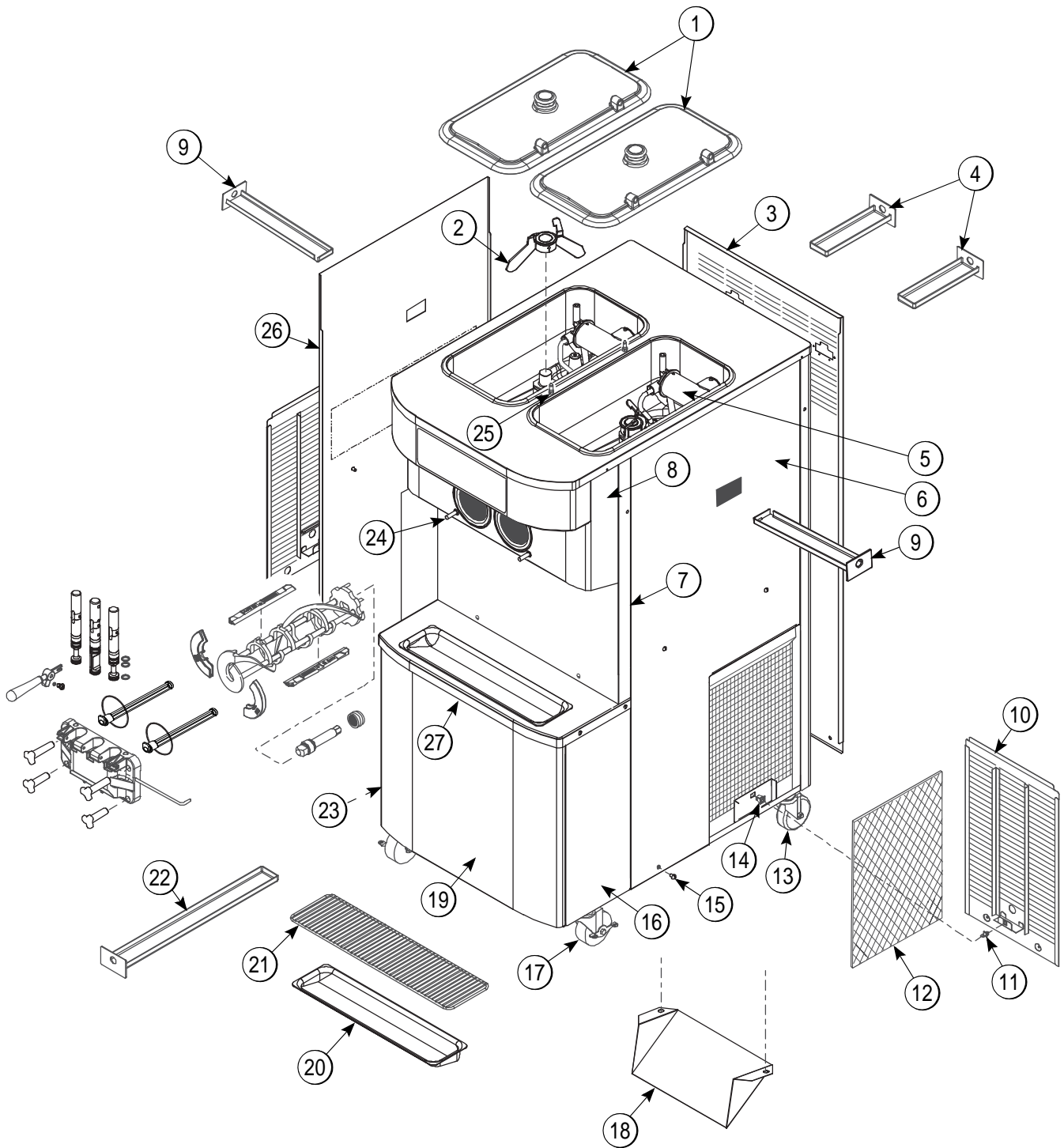

4

Figure 4-2

# OPERATOR PARTS IDENTIFICATION

## Model C716 Exploded View Parts Identification

Item	Description	Part No.
1	Kit A.-Cover-Hopper	X67061-AS
2	Blade A.-Agitator	X56591
3	Panel-Rear	064258-SER
4	Pan-Drip 7.875	059737
5	Pump A.-Mix Simplified	X57029-14
6	Panel-Side-Right	059907
7	Panel A.-Front Syrup Rail	X63884-40
8	Panel A.-Front	X59836
9	Pan-Drip 12.5	059736
10	Panel A.-Filter-Louvered	X59928
11	Fastener-Door Strike	030788
12	Filter-Air-Poly-FLo	052779-11
13	Caster-4" SWV 3/4-10 Stem	044106
14	Fastener-Door Latch	030787
15	Screw-1/4-20 X 3/8 RHM-SS	011694

Item	Description	Part No.
16	Panel-Corner-Front Right	063087
17	Caster-4" SWV 3/4-10 Stem w/ Brake	046437
18	Deflector	059929
19	Panel A.-Front Lower	X59854-SER
20	Tray-Drip-19-5/8 L X 4-7/8	033812
21	Shield-Splash-Wire-19-3/4 L	033813
22	Pan-Drip 19-1/2 Long	035034
23	Panel-Corner-Front-Left	063088
24	Stud-Nose Cone	055987
25	Pin-Retaining-Hopper CVR	043934
26	Panel-Side-Left	059906
27	Tray-Drip *C716*	063877
*	Fastener-Clip 1/4-20	045865

\*Not Shown

4

Model C708 Single Spout Door and Beater Assembly

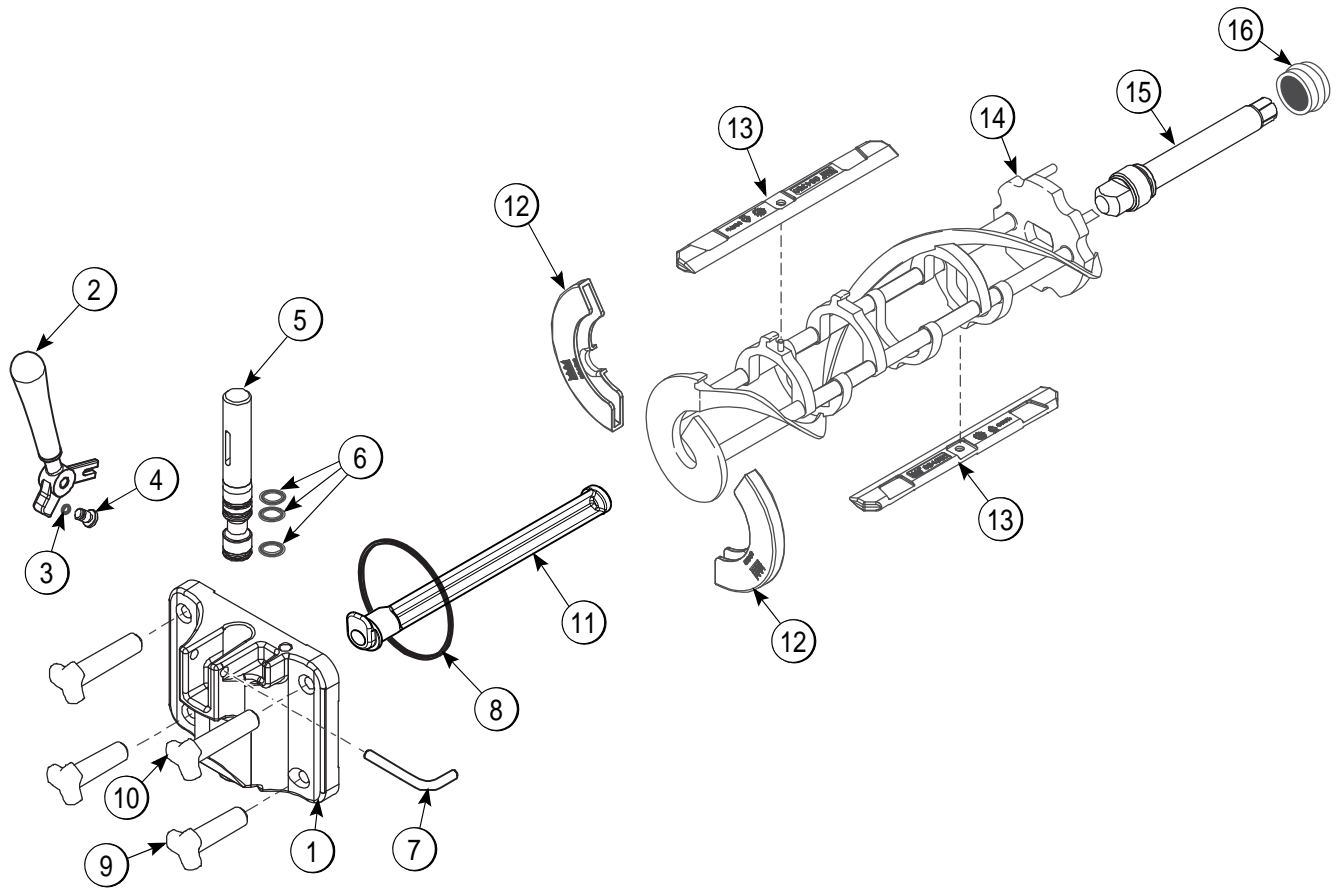

Figure 4-3

Item	Description	Part No.
1	Door A.	X87683-1
2	Handle A.-Draw-Welded	<a href="#">X56246</a>
3	O-ring-1/4 OD X.070W 50	015872
4	Screw-Adjustment-5/16-24	056332
5	Valve A.-Draw	<a href="#">X55820</a>
6	O-ring-Draw Valve-s.s.	014402
7	Pin-Handle-SS	055819
8	Gasket-Door Ht 4"-DBL	048926

Item	Description	Part No.
9	Nut-Stud-Black 2.563"	058764
10	Nut-Stud-Black 3.250"	058765
11	Baffle-Threadless Molded	087708
12	Kit A.-Beater-Front Shoes	<a href="#">X50350</a>
13	Blade-Scraper-Plastic	084350
14	Beater A.-3.4QT.-1 Pin	<a href="#">X46231</a>
15	Shaft-Beater	056078
16	Seal-Drive Shaft	032560

Model C716 Door and Beater Assembly

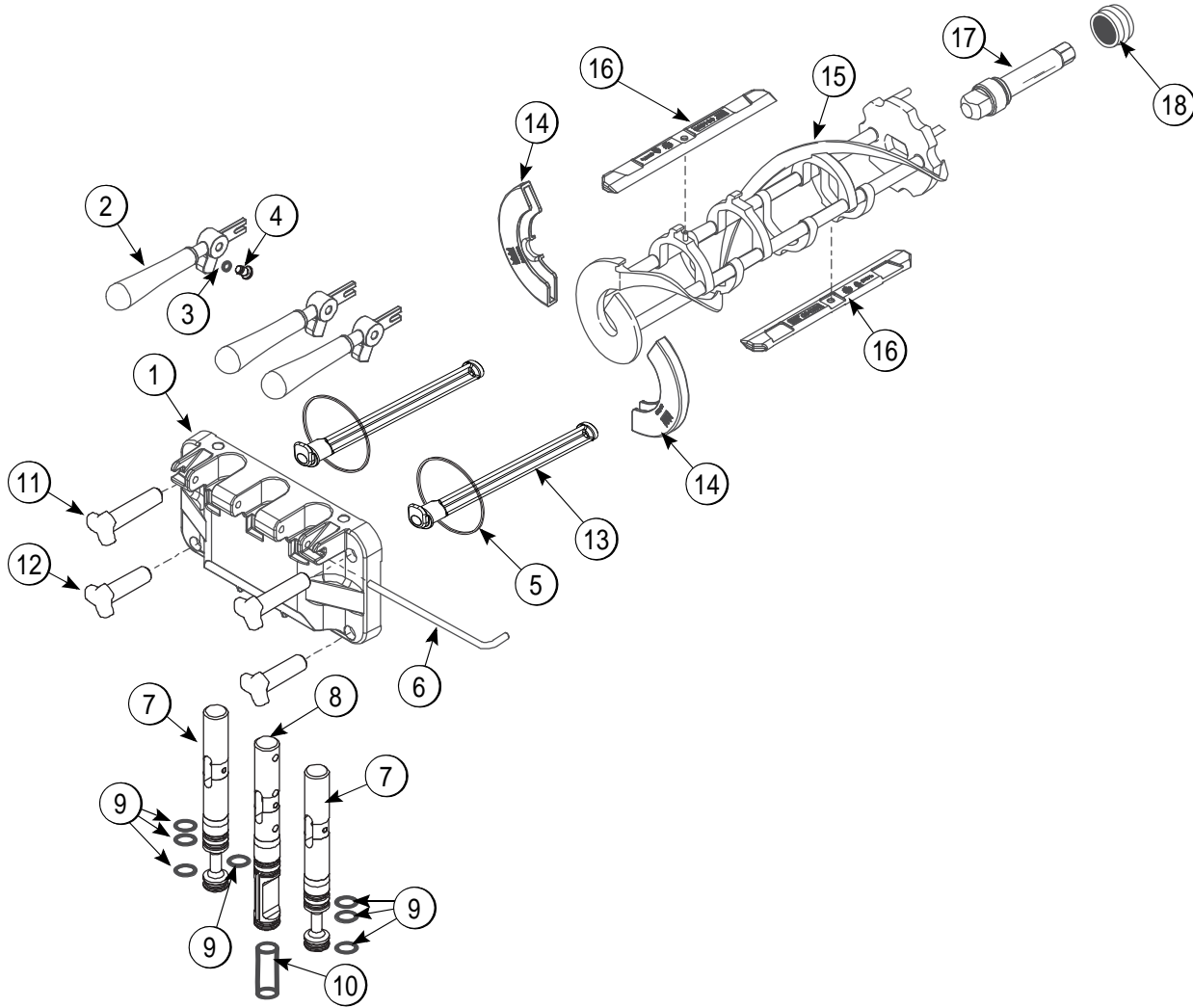

Figure 4-4

Item	Description	Part No.
1	Door A.-3SPT*HT*	X88684-1
2	Handle A.-Draw-Welded	<a href="#">X56421-1</a>
3	O-ring-1/4 OD X.070W 50	015872
4	Screw-Adjustment-5/16-24	056332
5	Gasket-Door Ht 4\"-Double	048926
6	Pin-Handle-Twin	059894
7	Valve A.-Draw	<a href="#">X59888</a>
8	VALVE A.-DRAW*CENTER	<a href="#">X59890</a>
9	O-ring--7/8 OD X.103W	014402

Item	Description	Part No.
10	Seal-Draw Valve	034698
11	Nut-Stud-Black 3.250 Long	058765
12	Nut-Stud-Black 2.563 Long	058764
13	Baffle-Threadless Molded	087708
14	Kit A.-Beater-Front Shoes-Bearing	<a href="#">X50350</a>
15	Beater A.-3.4QT.-1 Pin	<a href="#">X46231</a>
16	Blade-Scraper-Plastic	084350
17	Shaft-Beater	032564
18	Seal-Drive Shaft	032560

X57029-XX Pump A. - Mix Simplified (Models C708 & C716)

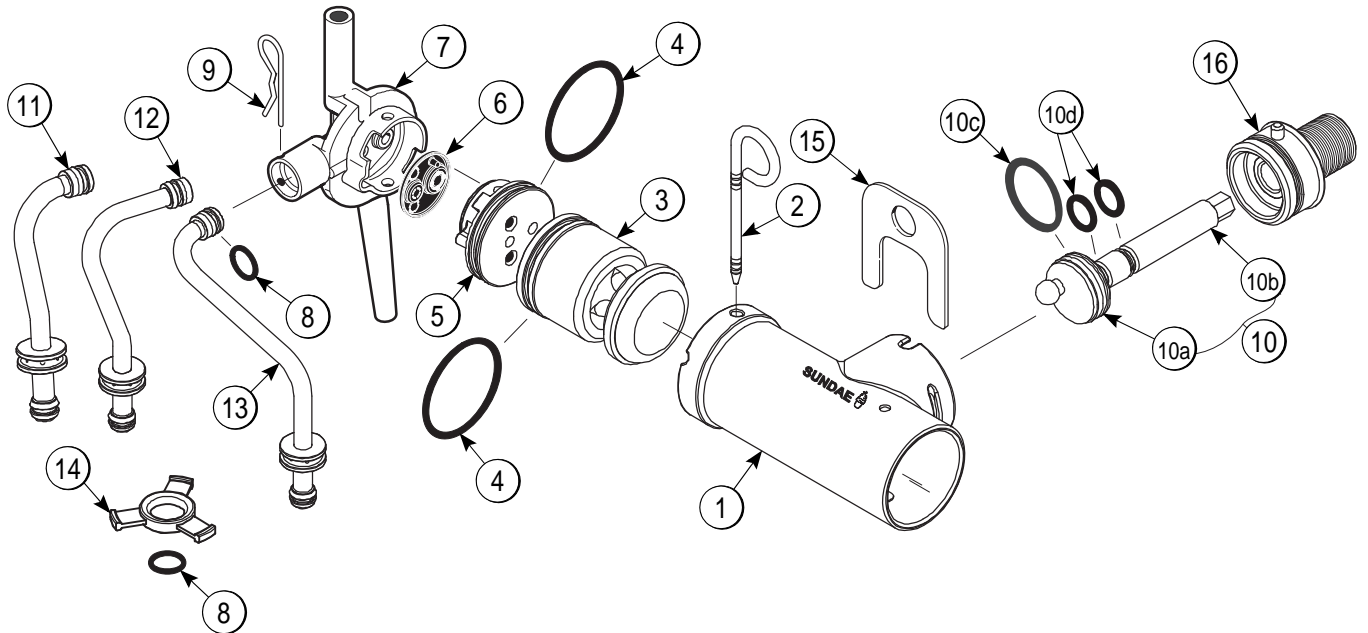

Figure 4-5

Item	Description	Part No.
1-7*	Pump Assembly - Mix Simplified Soft Serve	X57029-XX*
1	Cylinder-Pump-Hopper-SS	057943
2	Pin-Retaining	X55450
3	Piston-pump-simplified	053526
4	O-ring 2-1/8" OD - Red	020051
5	Cap-valve Body SS	056874-XX
6	Gasket-Simplified Pump Valve	086097
7	Adapter - Mix Inlet SS Red	054825
8	O-ring - 11/16 OD - Red	016132
9	Pin - Cotter	044731
10	Shaft A.-Drive-Mix Pump Hopper	X41947

Item	Description	Part No.
10a	Crank-Drive	039235
10b	Shaft-Drive	041948
10c	O-ring 1-3/4 OD X.139W	008904
10d	O-ring 1/2 Id X.139W	048632
11	Tube A.-Feed Hopper (C708)	X56521
12	Tube A.-Feed Right (C716)	X59809
13	Tube A.-Feed Left (C716)	X59808
14	Ring-Check.120 OD	056524
15	Clip-Mix Pump Retainer	044641
16	Sleeve A.-Mix Pump *HT	X44761

**Note:** \* The standard pump X57029-XX IS -14. Overrun can be changed higher or lower by substituting the cap (056874-XX) with caps available (1 through 20). The higher the dash (-) number, the higher the overrun.

Accessories

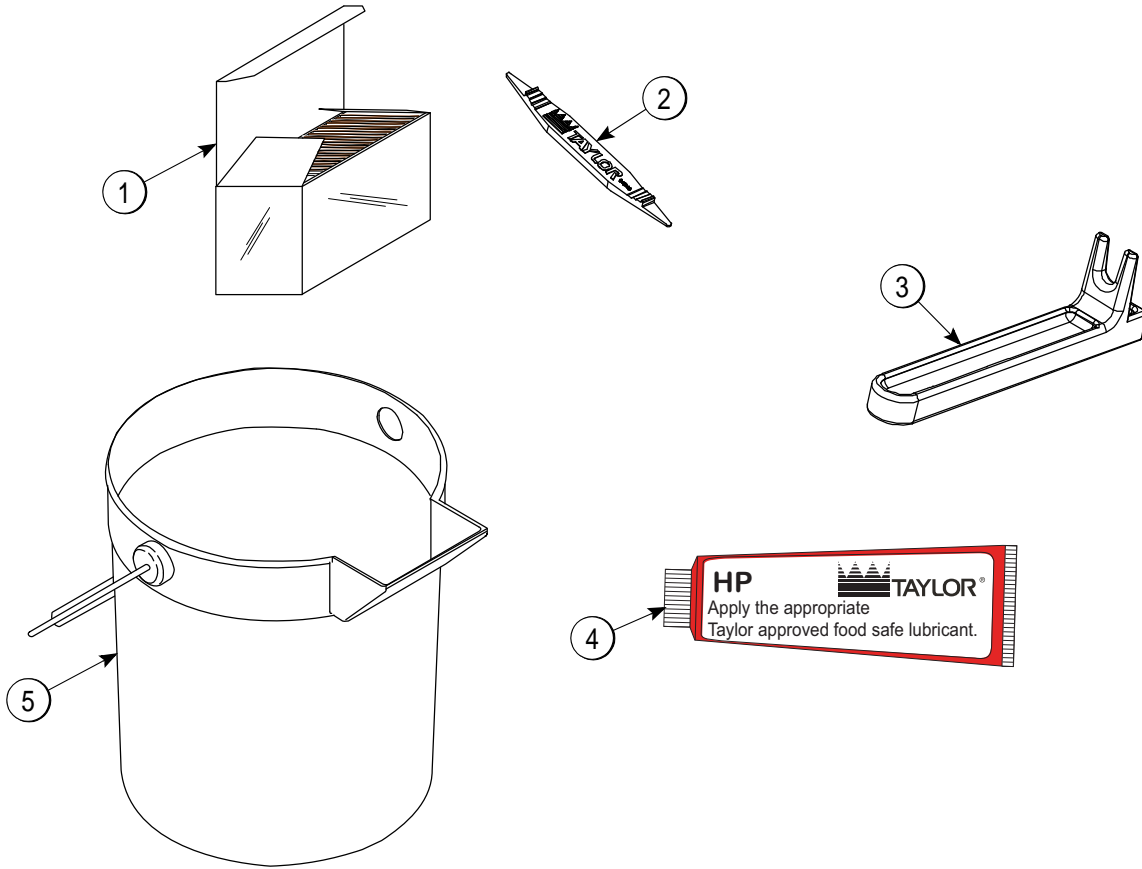

Figure 4-6

Item	Description	Part No.
1	Sanitizer-Stera Sheen	*See Note
2	Tool-O-ring Removal	048260-WHT
3	Tool-Shaft-Drive-Pump Hopper	057167
4	Lubricant-Taylor Hi-PERF	048232

Item	Description	Part No.
5	Pail-10 QT.	013163
**	Kit A.-Tune-Up (C708)	X63146
**	Kit A.-Tune-Up (C716)	X49463-82
**	Kit A.-Parts Tray (C708)	X57797
**	Kit A.-Parts Tray (C716)	X67432

\*Note: A sample container of sanitizer is sent with the machine. For reorders, order Stera-Sheen® part no. 055492 (100 2 oz. packs) or Kay-5® part no. 041082 (200 packs).

\*\*Not Shown

Brush A.-Package-HT X44127

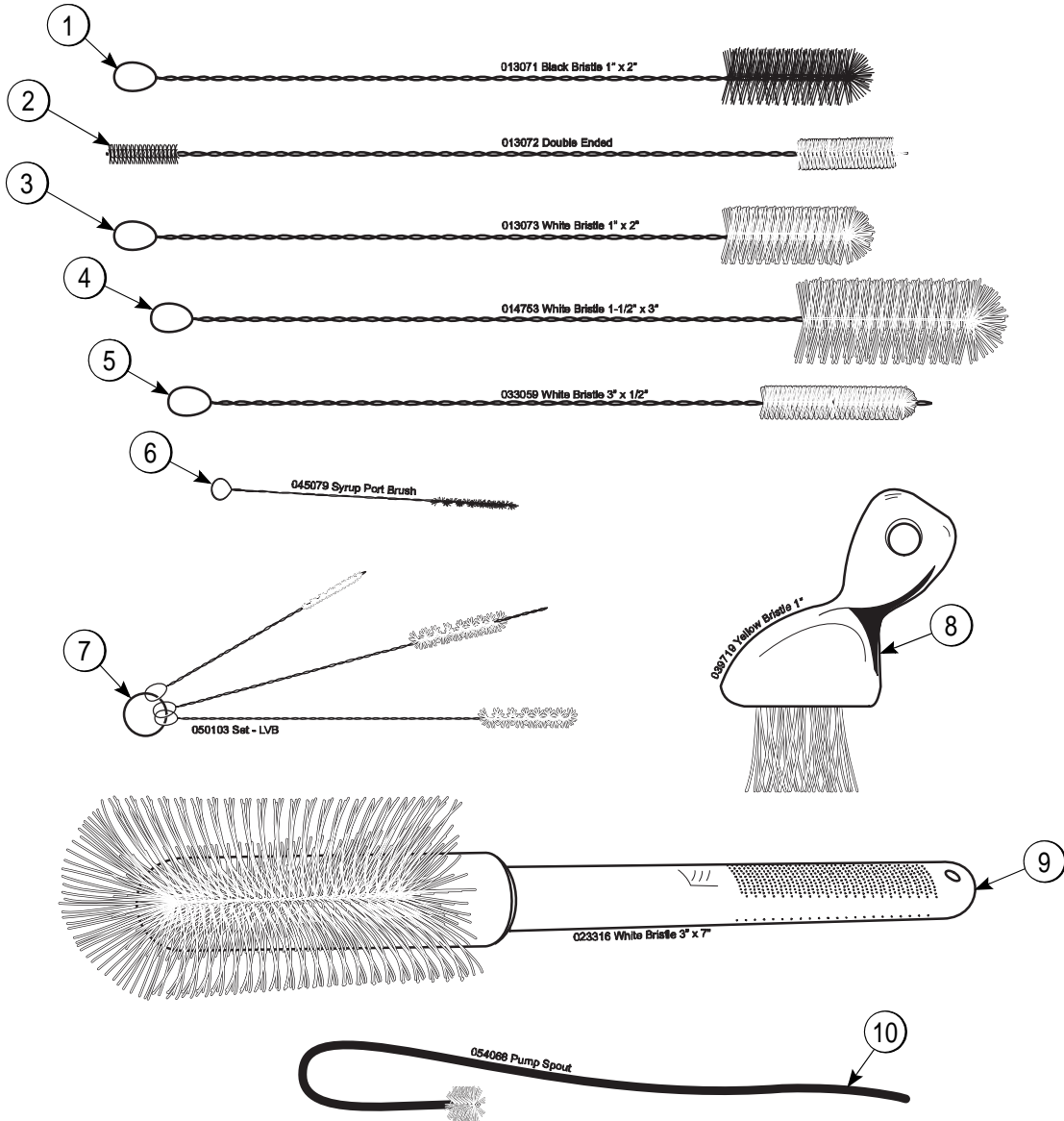

4

Figure 4-7

Item	Description	Part No.
1	Black Bristle Brush	013071
2	Double-End Brush	013072
3	Brush 1" X 2"	013073
4	Brush 1-1/2" X 3"	014753
5	Brush 1/2 X 3	033059

Item	Description	Part No.
6	Brush-Syrup Port	045079
7	Brush Set (3)	050103
8	Yellow Bristle Brush	039719
9	Brush 3" X 7"	023316
10	Pump Spout Brush	054068



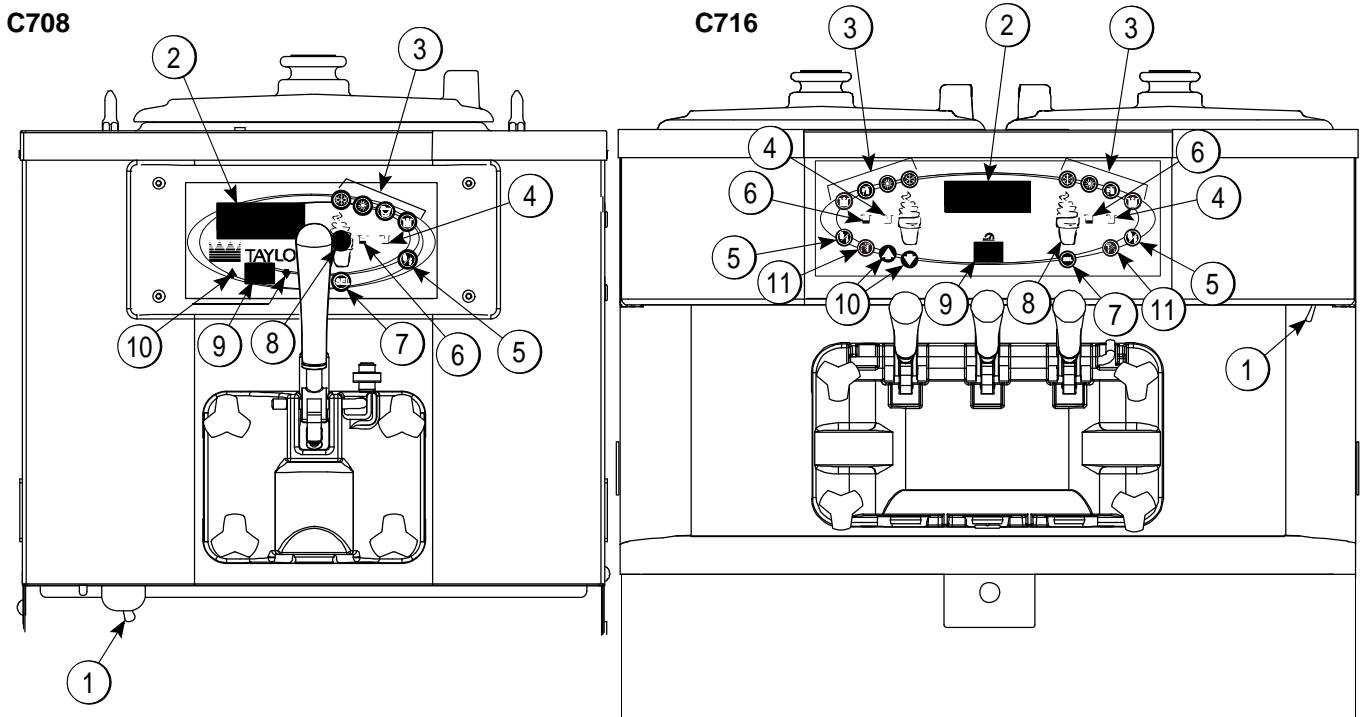

Figure 5-1

Item	Description
1	Power Switch
2	Liquid Crystal Display
3	Keypads
4	Mix Out Indicator
5	Standby Indicator
6	Mix Low Indicator
7	Select Key
8	Service Menu Key
9	Brush-Clean Counter
10	Arrow Key(S)
11	Topping Heater Key

## Symbol Definitions

To better communicate in the international arena, symbols have replaced words on many of our operator switches, function, and fault indicators. Your Taylor machine is designed with these international symbols.

The following chart identifies the symbol definitions:

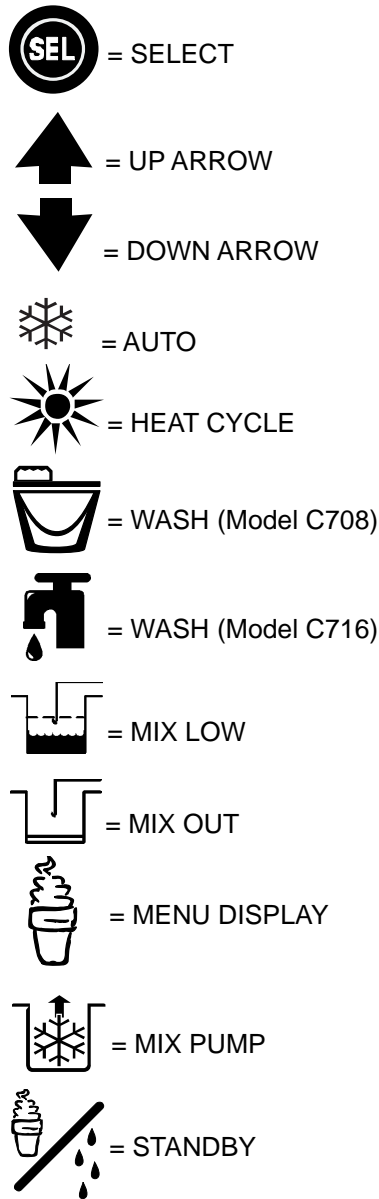

## Power Switch

When placed in the ON position, the power switch allows control panel operation.

## Fluorescent Display

The fluorescent display is located on the front control panel. During normal operation the display is blank. The display is used to show menu options and notifies the operator if a fault is detected. On international models the display will indicate the temperature of the mix in the hopper.

## Indicator Lights

**MIX LOW**—When the Mix Low key  is illuminated, the mix hopper has a low supply of mix and should be refilled as soon as possible.

**MIX OUT**—When the Mix Out  key is illuminated, the mix hopper has been almost completely exhausted and has an insufficient supply of mix to operate the freezer. At this time, the Auto mode is locked out and the freezer is placed in the Standby mode. To initiate the refrigeration system, add mix to the mix hopper and

press the Auto key . The freezer will automatically begin operation.

**HEAT MODE**—When the Heat Mode key  is illuminated, the freezer is in the process of a heat cycle. If enabled, the Heat key can be pressed to start a heat cycle. If disabled, the Heat key is inoperable. By default, the Heat key is enabled.

**BRUSH-CLEAN COUNTER** - When the Brush-Clean Counter display has counted down to 1, the machine must be disassembled and brush-cleaned within 24 hours.

## Reset Mechanism



The reset button is located in the service panel on the left side of the C708. The reset buttons are located in the back panel of the C716. A reset button protects the beater motor from an overload condition. Should an overload occur, the reset mechanism will trip. To properly reset, the freezer place the power switch in the OFF position. Press the reset button firmly and turn the power

switch to the ON position. Press the Wash key  and observe the freezer's performance.



**WARNING: Do not use metal objects to press the reset button.** Failure to comply may result in severe personal injury or death.

If the beater motor is turning properly, press the Wash

key  to cancel the cycle. Press the Auto key  to resume normal operation. If the freezer shuts down again, contact your authorized service technician.

### Air/Mix Pump Reset Mechanism

This reset button protects the pump from an overload condition. Should an overload occur, the reset mechanism will trip. To reset the pump, press the reset button firmly.



**WARNING: Do not use metal objects to press the reset button.** Failure to comply may result in severe personal injury or death.

### Adjustable Draw Handle

These machines feature adjustable draw handles to provide the best portion control, giving a better, more consistent quality to your product and controlling costs. The draw handle(s) should be adjusted to provide a flow rate of 5 oz. to 7-1/2 oz. (142 g to 213 g) of product by weight per 10 seconds. To **increase** the flow rate, turn the screw **clockwise**. To **decrease** the flow rate, turn the screw **counterclockwise**. (See Figure 5-2.)

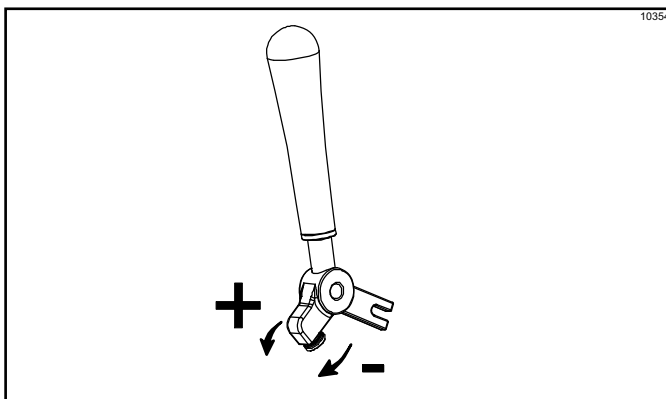

Figure 5-2

## Operating Screen Descriptions

The fluorescent display in the center of the control panel is normally blank during the daily operation of the machine. The display is activated when the SEL key or the Manager's Menu is selected. The display screen will also alert the operator of specific faults detected by the control.

**Note:** *The displays illustrated in this section are those seen on the models C708. The model C716 displays vary slightly.*

### Power Up Memory (Initializing)

The seven segment display should display 00 during the initializing sequence.

When the machine is powered, the control system will initialize to perform a system check. The screen will display INITIALIZING. There will be four types of data the system will check: LANGUAGE, SYSTEM DATA, CONFIG DATA, and LOCKOUT DATA.

### Language Initialization

The UVC platform supports multiple languages by keeping specific strings in battery backed RAM.

After power-up or a CPU reset, the language strings are tested to see if they are present and not corrupted. If the strings are present and not corrupted, initialization continues. Otherwise, the operator is prompted to select a language. While language strings are being checked for integrity, the following screen is displayed:



**Note:** *If there is a language initialization fault, the machine will force a language selection prior to the initializing sequence. The standard menu LEDs should light as if they were in a menu. If a language has been selected, the machine is powered down. The machine should not ask for a language unless there is another language initialization fault. English is the factory default setting.*

## System Data

System data is protected separately from the rest of the data in memory. System data includes variables that change frequently, such as the mode the machine is in, lockout status, serving counters, fault codes, and others. While System data is being checked the following screen is displayed:



If the System data is corrupted, the machine is set to Off, the serving counters are set to zero, and the faults are cleared. A SYSTEM CRC ERR fault is set and displayed on the VFD. An acknowledgment (SEL key) is required.

**Configuration Data**—Configuration data is separate from the rest of the data in the memory. Configuration data is entered through operator and service menus. While Configuration data is being checked, the following screen is displayed:



If Configuration data is corrupted, all user and service settings are set to defaults. A CONFIG CRC ERR fault is set and displayed on the VFD. The system will continue to operate in its previous mode, but according to default settings.

**Lockout Data**—Lockout data is protected separately from the rest of the data in the memory. While the Lockout data is being checked, the following screen is displayed:



If Lockout data is corrupted, all lockout history data is cleared. A LOCKOUT CRC ERR fault is displayed. After the memory integrity has been tested, the Safety Timeout screen will be displayed.

**Heat Cycle Data**—Heat Cycle data is checked separately from the rest of the data in memory. Each individual Heat Cycle data record is monitored for corruption individually. At the start of a Heat cycle, the next Heat Cycle data record is cleared and data for the Heat cycle is written to it. The current Heat Cycle data is displayed as the first Heat cycle record in the HEAT CYCLE DATA menu option.

The Heat Cycle data records are checked for integrity when the record is accessed, presently only through the HEAT CYCLE DATA menu option. For additional Heat Cycle data information, see page 5-13.

**SAFETY TIMEOUT**—Once the system has initialized, the number of days until brush-cleaning is required is indicated on the control panel. The SAFETY TIMEOUT screen will be displayed with the alarm on for 60 seconds or until any control key is pressed.

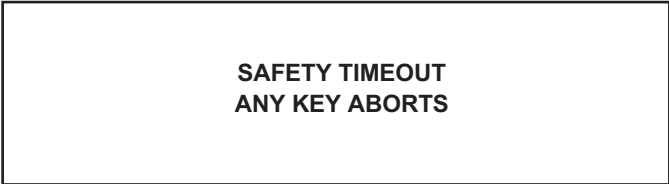

**Power Switch OFF**—After the SAFETY TIMEOUT has been completed and the power switch is Off, the following screen is displayed:

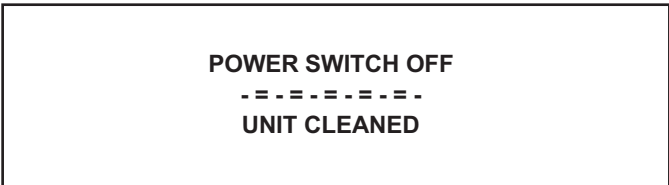

**Power Switch ON**—When the power switch is placed in the ON position, the control panel touch keys become operative. The fluorescent display will be either blank or indicate that the unit has been cleaned.

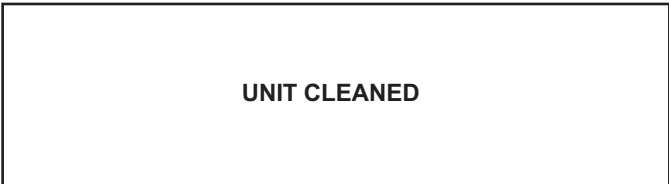

## International Models Only

Some international models will continuously display the temperature of the mix hopper when the power switch is in the ON position.

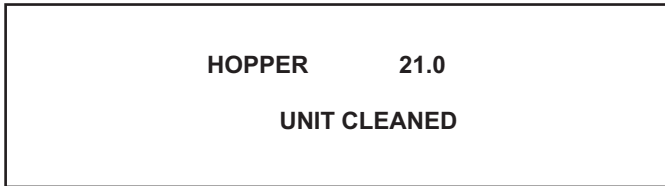

If the control is set for international configuration, the following screen will appear when the Heat key is pressed:



Use the Up or Down Arrow key to move the cursor to Yes. Press the SEL key to immediately start a Heat cycle.

**Note:** The machine must be in Auto or Standby mode and have sufficient mix in the hopper before the machine can successfully enter the Heat mode of operation.

## Heat Cycle

The Heat key on the control panel is illuminated throughout the Heat Treatment Cycle. Two warning messages will be displayed on the screen. DO NOT DRAW will be displayed when the mix temperature is below 130°F (54.4°C).



When the mix temperature is above 130°F (54.4°C), the screen will display a message indicating that HOT PRODUCT is in the machine.



**DO NOT** attempt to draw product or disassemble the unit during the Heat cycle. The product is hot and under extreme pressure.

In the Heat cycle, the mix temperature in the hopper and freezing cylinder must be raised to 151°F (66.1°C) within 90 minutes.

When the heating phase is complete, the freezer goes into the holding phase of the cycle. The holding phase will keep the temperature above 151°F (66.1°C) for a minimum of 35 minutes.

The final phase of the Heat Treatment Cycle is the Cooling phase. The freezer must cool the mix below 41°F (5°C) within 90 minutes.

When the entire Heat cycle has been completed, the Heat key will no longer be illuminated. The machine will enter the Standby mode (Standby key illuminates). The machine can be placed in Auto or left in Standby.

To comply with health codes, heat treatment system freezers **must** complete a Heat Treatment Cycle daily and **must** be disassembled and brush-cleaned according to the frequency specified by your federal, state, or local regulatory agencies. Please consult your governing food code to determine the maximum number of days allowed between brush-clean cycles.

Brush-cleaning is the normal disassembly and cleaning procedure found in the Operator's Manual. Failure to follow these guidelines will cause the control to lock the freezer out of the Auto mode.

If the Heat Treatment Cycle fails, the screen will display a failure message and return the freezer to the Standby mode.

Always comply with local guidelines for the maximum number of days allowed between brush-clean cycles.

## Freezer Locks

There are two types of freezer locks that can occur: hard lock or soft lock. A hard lock requires the machine be disassembled and brush-cleaned. A soft lock can be corrected by either disassembling and brush-cleaning the machine or by starting another Heat Treatment Cycle.

## Hard lock

There are two causes of a hard lock failure. The freezer will hard lock if either the Brush Clean Timer has elapsed or if a thermistor failure (freezing cylinder or hopper) occurred during a Heat cycle.

1. The following screen will be displayed if a Brush Clean Cycle Time has occurred:

```

BRUSH CLEAN TIMEOUT
FREEZER LOCKED
CLEANING REQ'D
> WASH TO BRUSH CLEAN
    
```

Pressing the SEL key will display the following screen:

```

FREEZER LOCKED
    
```

2. The following screen will display if there has been a thermistor failure (freezing cylinder or hopper) during the heat treatment process:

```

SYSTEM FAULT
FREEZER LOCKED
SERVICE REQ'D
> WASH TO BRUSH CLEAN
    
```

Pressing the SEL key will indicate which thermistor caused the hard lock.

```

HOPPER THERM BAD
FREEZER LOCKED
    
```

If the machine has hard locked and an attempt is made to enter Auto mode, the machine will enter the Standby mode and display the following message:

```

FREEZER LOCKED
    
```

To restore the message that identified the reason for the hard lock, turn the power switch off for 5 seconds and then return the power switch to the ON position.

The original message with the reason for the hard lock will be displayed.

The FREEZER LOCKED message will remain on the display until the brush-clean requirements are fulfilled. The freezer must be disassembled to activate the 5-minute timer on the display screen. Once the timer counts down to zero, the lockout is cleared.

## Soft Lock

If a Heat Treatment Cycle has not been initiated within the last 24 hours, a soft lock failure will occur. A soft lock allows the operator to correct the cause. The operator has the option of either starting another Heat cycle or brush-cleaning the machine. When a soft lock occurs, the machine will go into the Standby mode. The following message is displayed on the screen; the reason for the soft lock is indicated on the second line:

```

NO HEAT CYCLE START
REASON
> HEAT FOR HEAT CYCLE
WASH TO BRUSH CLEAN
    
```

If the reason for the soft lock has been corrected, selecting HEAT CYCLE initiates a Heat Cycle immediately. Selecting BRUSH CLEAN when the previous message is displayed will hard lock the machine and brush-cleaning will be necessary.

Following are the variable messages for soft lock failures that appear on the second line of the screen:

POWER SWITCH OFF	Power switch was in the OFF position.
MIX OUT PRESENT	There was a mix out condition present.
AUTO OR STANDBY OFF	The machine was not in the Auto or Standby mode.
NO HEAT CYCLE TRIED	A Heat Treatment Cycle was not attempted in the last 24 hours. (AUTO HEAT TIME was advanced or a power loss was experienced at the time the cycle was to occur.)

If the following screen appears, a soft lock has occurred during the Heat Treatment Cycle:

HEAT TREAT FAILURE  
 FREEZER LOCKED  
 > HEAT FOR HEAT CYCLE  
 WASH TO BRUSH CLEAN

A soft lock can also occur anytime during operation when the hopper or freezing cylinder temperature rises above 59°F (15°C), the temperature rises and remains above 45°F (7°C) for more than 1 hour, or the temperature rises and remains above 41°F (5°C) for more than 4 hours.

If a Product Over Temperature condition occurs during operation, the following screen will appear:

PRODUCT OVER TEMP  
 > HEAT FOR HEAT CYCLE  
 WASH TO BRUSH CLEAN

When one of these messages appears, automatic freezer operation cannot take place until the freezer is disassembled and brush-cleaned or has completed a Heat Treatment Cycle.

Once the freezer is unlocked by starting a Heat Treatment Cycle, the Heat key will illuminate and the following message will be displayed on the screen:

DO NOT DRAW

If BRUSH CLEAN is selected to clear the lockout by brush-cleaning the machine, the FREEZER LOCKED message will remain on the display until the brush-clean requirements are fulfilled. The freezer must be disassembled to activate the 5-minute timer on the display screen. Once the timer counts down to zero, the lockout is cleared.

FREEZER LOCKED

To restore the message that identified the reason for the soft lock, turn the power switch off for 5 seconds and then return the power switch to the ON position. The original message with the reason for the soft lock will be



displayed:

HEAT TREAT FAILURE  
 REASON  
 > HEAT FOR HEAT CYCLE  
 WASH TO BRUSH CLEAN

**Note:** A record of Heat Cycle Data and lock out history can be found in the Manager's Menu.

### Manager's Menu

The Manager's Menu is used to enter the operator function displays. To access the menu, press the center

of the Cone  key on the control panel. The arrow 

 keys, the Select  key and the Cone  key will be lit when the ACCESS CODE screen is displayed.

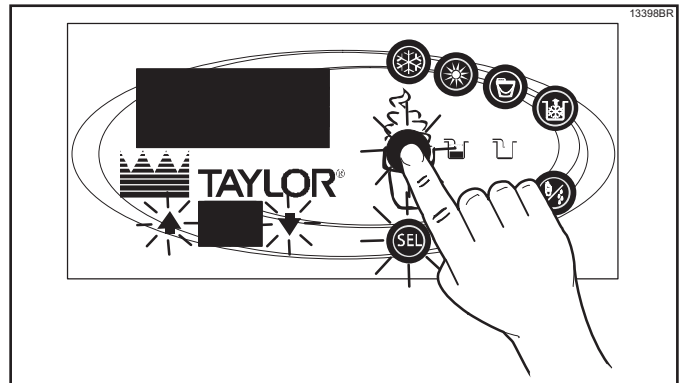





Figure 5-3

In the Manager's Menu program, the arrow keys and the SEL key will function as menu keys.

- **Up Arrow**  —increases the value above the cursor and is used to scroll upward in text displays.
- **Down Arrow**  —decreases the value above the cursor and is used to scroll downward in text displays.
- **Select**  —advances the cursor position to the right and is used to select menu options.

There is a 2-minute time-out in effect during the Manager's Menu. While in the Manager's Menu, if no activity occurs within a 2-minute period, the display will exit to the Main Menu. There is one exception to this time-out, and that is the CURRENT CONDITIONS display.

**Note:** The machine will continue operation in the mode it was in when the Manager's Menu was selected. However, the control keys will not be lit and are nonfunctional when the Manager's Menu is displayed. The control keys are functional in the Manager's Menu when the CURRENT CONDITIONS screen is displayed. (See Current Conditions on page 5-15.)

### Entering Access Code

With the ENTER ACCESS CODE screen on the display, use the SEL key to set the first code number in the cursor position. When the correct number is selected, press the SEL key to move the cursor to the next number position.



Continue to enter the proper access code numbers (8309) until all four numbers are displayed, then press the SEL key. The Manager's Menu will display on the screen, provided the correct access code is entered.

If an incorrect number is entered for the access code, the display will exit the Manager's Menu program when the SEL key is pressed.

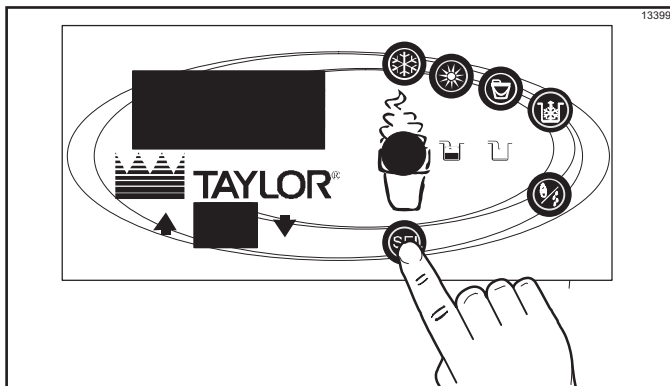

Figure 5-4

### Manager's Menu Options

Press the arrow keys to move up or down through the Menu. Select a menu option by pressing the SEL key. Exit the Manager's Menu by selecting EXIT FROM MENU or press the Cone key.

The following menu options are listed in the Manager's Menu:

- EXIT FROM MENU
- SERVINGS COUNTER
- SET CLOCK
- AUTO HEAT TIME
- AUTO START TIME
- AUTO STANDBY TIME
- AGITATOR OPERATION
- MIX LEVEL AUDIBLE
- FAULT DESCRIPTION
- FAULT HISTORY
- LOCKOUT HISTORY
- HEAT CYCLE SUMMARY
- HEAT CYCLE DATA
- SYSTEM INFORMATION
- CURRENT CONDITIONS
- ENABLE WIFI

**Exit From Menu**—Select EXIT FROM MENU to exit the Manager's Menu and return the control panel keys to normal operation.

**Servings Counter**—The SERVINGS COUNTER screen is used to check or reset the number of servings dispensed from the machine. The servings counter will automatically reset to zero when the machine is brush-cleaned.

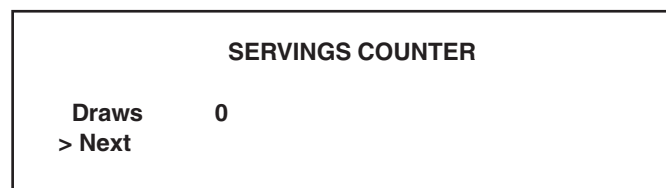

Reset the SERVINGS COUNTER by pressing the Select key to advance to the next screen. Press the Up Arrow key to move the arrow (>) to Yes and press the SEL key. The servings counter will reset to zero and exit back to the Manager's Menu.

```

RESET COUNTERS
ARE YOU SURE ?
> Yes
  No
    
```

**Set Clock**—The SET CLOCK screen allows the manager to adjust clock date and time. Date and time may only be changed after the freezer has been manually cleaned but before it has been placed in the Auto or Standby mode. The following message will be displayed if the SET CLOCK option is selected when the machine is not in a brush-clean state:

```

SET CLOCK
12:01      6/10/2010
NO CHANGES ALLOWED
Press Any Key
    
```

To change the date or time, select the SET CLOCK option in the menu. Press the Up Arrow key to advance the arrow from Exit to Change, then press the SEL key to select the Change option.

```

SET CLOCK
12:01      6/10/2010
  Change
> Exit
    
```

Change the time by pressing the Up Arrow with the cursor under the hour position. Move the cursor to the minutes position by pressing the SEL key. Once the correct minutes are entered, press the SEL key to advance the cursor to the month.

```

SET CLOCK
12:01      6/10/2010
> Exit
    
```

Enter the correct month, day, and year. Then press the SEL key to advance to the DAYLIGHT SAVING TIME (DST) screen.

```

DAYLIGHT SAVING TIME
ENABLED
> Enable
  Disable
    
```

Pressing the Up or Down Arrow keys will move the arrow to Enable or Disable. Pressing the SEL key next to Disable selects that option and returns to the Manager's Menu. Pressing the SEL key next to Enable selects that option and displays the second screen.

```

MAR Second Sunday
NOV First Sunday
  Change
> Exit
    
```

If the correct Sunday for the time change is not displayed, then Change should be selected. Pressing the SEL key with the arrow next to Change displays the third screen. Press the Up or Down Arrow key to move the arrow to the appropriate month for the start of DST.

```

DST START MONTH
> MAR
  APR
  MAY
    
```

Pressing the SEL key with the arrow next to the appropriate month will display the following screen:

```

DST START WEEK
> Second Sunday
  Third Sunday
  Fourth Sunday
    
```

Pressing the Up or Down Arrow key will move the arrow to the appropriate week for the start of DST. Pressing the SEL key next to the appropriate week will display the following screen. Press the Up or Down Arrow key to move the arrow to the appropriate month for the end of DST.

```

DST END MONTH
> NOV
  DEC
    
```

Pressing the SEL key next to the appropriate month will display the following screen. Press the Up or Down Arrow key to move the arrow to the appropriate week for the end of DST.

DST END WEEK  
 > First Sunday  
 Second Sunday  
 Third Sunday

Pressing the SEL key with the arrow by the appropriate week will select that setting and return to the Manager's Menu.

**Auto Heat Time**—The AUTO HEAT TIME screen allows the manager to set the time of day at which the Heat Treatment Cycle will start.

AUTO HEAT TIME  
 00:00  
 Change  
 > Exit

To set AUTO HEAT TIME, press the Up Arrow key to move the arrow to Change. Then press the SEL key. The screen will display the time with the cursor under the hour position.

AUTO HEAT TIME  
 00:00

Press the arrow keys to increase or decrease the hour to the desired setting. Then move the cursor to the minutes position by pressing the SEL key. Adjust the setting for minutes. Then press the SEL key to save the setting and return to the AUTO HEAT TIME screen. Press the SEL key to exit the screen and return to the Manager's Menu.

**Auto Start Time**—The AUTO START TIME screen allows the manager to set the time of day at which the machine automatically enters the Auto mode from the Standby mode. The machine must be in the Standby mode without a freezer lock condition in order to Auto start at the programmable time. The Auto Start Time can also be disabled and require starting the Auto mode manually.

AUTO START TIME  
 DISABLED  
 Enable  
 > Disable

Enable AUTO START TIME by pressing the Up Arrow key to move the arrow up to Enable. Press the SEL key to advance to the next screen.

AUTO START TIME  
 00:00  
 Change  
 > Exit

Program AUTO START TIME by pressing the Up Arrow key to move the arrow to Change. Press the SEL key to advance to the next screen.

AUTO START TIME  
 00:00

Use the arrow keys to program the AUTO START TIME by increasing or decreasing the hour setting above the cursor. Press the SEL key to advance the cursor and program the minutes. Press the SEL key to return to the previous screen with the new time setting displayed. Press the SEL key to exit the screen and return to the Manager's Menu.

**Auto Standby Time**—The AUTO STANDBY TIME screen allows the manager to set the time of day at which the machine automatically enters the Standby mode from the Auto mode. This saves power during slow sales. By default, this feature is disabled. Enable the AUTO STANDBY TIME by pressing the Up Arrow key to move the arrow up to Enable. Press the SEL key to advance to the next screen.

AUTO STANDBY TIME  
 DISABLED  
 > Enable  
 Disable

Program AUTO STANDBY TIME by pressing the Up Arrow key to move the arrow to Change. Press the SEL key to advance to the next screen.

AUTO STANDBY TIME  
 00:00  
 Change  
 > Exit

Use the arrow keys to program the AUTO STANDBY TIME by increasing or decreasing the hour setting above the cursor. Press the SEL key to advance the cursor and program the minutes setting. Press the SEL key to return to the previous screen with the new time setting displayed. Press the SEL key to exit the screen and return to the Manager's Menu.

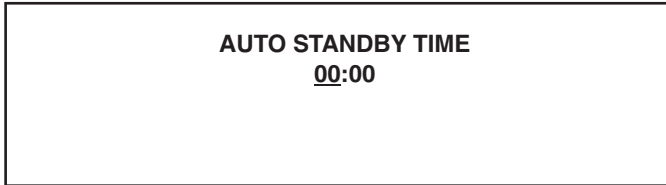

### Agitator Operation

The AGITATOR OPERATION screen allows the manager to select either continuous or intermittent agitator operation.

AGITATOR OPERATION may be set to operate in the standard mode or "with Hopper Refrig." In the standard mode, the agitator operates during Auto, Standby, and Heat Treat. In the "with Hopper Refrig" mode, it runs only when the hopper is refrigerating and during the Heat, Hold, and Soak phases of a Heat cycle, and the Cool phase of a Heat cycle if the hopper is refrigerating. The default is standard operation.

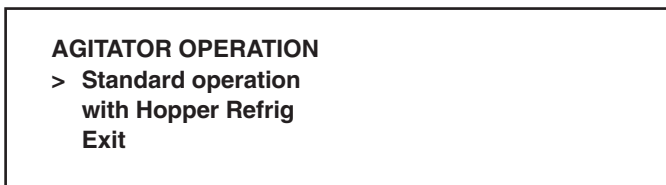

Use the arrow keys to move to the desired operation and press the SEL key to accept the selection.

### Mix Level Audible

The MIX LEVEL AUDIBLE screen, when enabled, will alert the operator with an audible tone when there is a Mix Low or Mix Out condition. The following screen is displayed upon selecting this option:

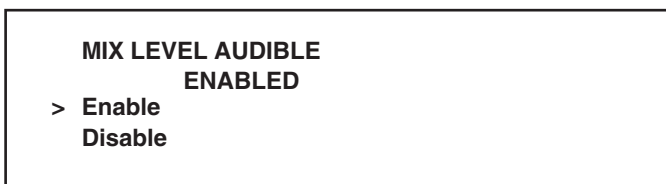

Disable the audible tone feature by pressing the Down Arrow key to move the arrow to Disable. Press the SEL key to save the new setting and return to the Manager's

Menu. The control panel icons for Mix Low and Mix Out will illuminate as the mix level drops in the hopper, but the audible tone will be disabled.

### Fault Description

The FAULT DESCRIPTION screen will indicate a fault with the freezer and where the fault occurred. When no faults are detected, the following screen will be displayed:

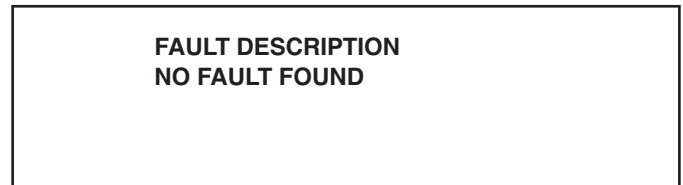

Press the SEL key to display the next fault found or return to the Manager's Menu if no other faults exist. Pressing the SEL key anytime faults are displayed will clear the faults, if corrected, upon returning to the menu screen.

Listed below are the variable messages which will appear, along with an explanation for the corrective action.

**NO FAULT FOUND**—There was no fault found in the freezer. Nothing will appear on the screen after this variable message appears.

**BEATER OVERLOAD**—Place the power switch in the OFF position. Wait 5 minutes for the machine to cool. Press the beater reset button firmly. Place the power switch in the ON position and restart in Auto mode.

**COMPRESSOR HPCO**—Place the power switch in the OFF position. Wait 5 minutes for the machine to cool. Place the power switch in the ON position and restart in Auto mode.

**HOPPER THERMISTOR FAIL\***—Place the power switch in the OFF position. Call a service technician.

**BARREL THERMISTOR FAIL\***—Place the power switch in the OFF position. Call a service technician.

**Note:** \* Three codes have been set up to assist in diagnosing bad thermistor probes. If a probe has shorted (resistance less than 1 ohm), SHRT will display its machine location. If the probe is open (resistance above 1 megohm), OPEN will display. If the actual probe environment exceeds 200°F (93°C), the respective screen display location will read OVER, indicating the temperature is out of range.

**COMP ON TOO LONG**—The compressor run time exceeded the 11-minute timer.

## Fault History

The FAULT HISTORY screens will display up to 100 faults that have occurred. The most recent fault is displayed on screen 1. The date, time, and fault description are displayed on each screen.

<b>FAULT HISTORY</b>	<b>1</b>
00/00/00	00:00
<b>REASON</b>	
> Exit	

## Lockout History

The LOCKOUT HISTORY screens display a history of the last 100 soft locks, hard locks, brush-clean dates, or aborted heat cycles. Page numbers are indicated in the upper right hand corner. Page 1 always contains the most recent failure.

<b>LOCKOUT HISTORY</b>	<b>1</b>
00/00/00	00:00
<b>REASON</b>	
> Exit	

The second line of the screen displays the date and time a failure occurs. The third line indicates the reason for a failure or will indicate if a successful brush-cleaning has occurred. Some failures are for multiple reasons. When this occurs, a page will be generated for each reason.

Use the arrow keys to advance forward or move backward to view each screen. Listed below are the variable messages that may appear.

## Faults Occurring Entering Heat Treat Cycle

**POWER SWITCH OFF**—The power switch is off.

**AUTO OR STBY OFF**—The control was not in the Auto or Standby mode.

**MIX OUT FAILURE**—A Mix Out condition was present.

**NO HEAT CYCLE TRIED**—The Auto Heat Time was set to attempt a Heat cycle more than 24 hours after the last successful Heat cycle.

## Faults Occurring While in Heat Mode:

**HEAT MODE FAILURE**—The maximum allowable Heat mode time exceeded 90 minutes.

**COOL MODE FAILURE**—The maximum allowable Cool mode time exceeded 90 minutes for UVC3 units, or 120 minutes for UVC4 units.

**TOTAL TIME FAILURE**—The maximum allowable total Heat Treatment time exceeded 4 hours.

**BRUSH CLEAN TIMEOUT**—The total days in operation exceeded the brush-clean cycle setting.

**POWER SWITCH OFF**—The power switch was turned off during the Heat cycle.

**POWER FAIL IN H/C**—A power failure occurred during the Heat Treatment Cycle.

**MIX LOW FAILURE**—The mix level in the hopper is too low for a successful Heat cycle.

**BEATER OVLD H/C**—The overload tripped for the beater motor.

**BRL THERM FAIL**—The thermistor sensor for the freezing cylinder failed.

**HOPPER THERM FAIL**—The thermistor sensor for the hopper failed.

**HPCO H/C**—The high-pressure switch opened during the Heat Treatment Cycle.

## Faults Occurring While in Auto Mode:

**(L/R) HPR>41F (5C) AFTER 4 HR**—The mix temperature in the hopper was above 41°F (5°C) more than 4 hours.

**(L/R) BRL>41F (5C) AFTER 4 HR**—The mix temperature in the freezing cylinder (barrel) was above 41°F (5°C) more than 4 hours.

**(L/R) HPR>41F (5C) AFTER PF**—The mix temperature in the hopper was above 41°F (5°C) more than 4 hours following a power failure.

**(L/R) BRL>41F (5C) AFTER PF**—The mix temperature in the freezing cylinder (barrel) was above 41°F (5°C) more than 4 hours following a power failure.

**(L/R) HPR>45F (7C) AFTER 1 HR**—The mix temperature in the left or right hopper was above 45°F (7°C) more than 1 hour.

**(L/R) BRL>45F (7C) AFTER 1 HR**—The mix temperature in the left or right freezing cylinder (barrel) was above 45°F (7°C) more than 1 hour.

**(L/R) HPR>59F (15C)**—The mix temperature in the hopper exceeded 59°F (15°C).

**(L/R) BRL>59F (15C)**—The mix temperature in the freezing cylinder (barrel) exceeded 59°F (15°C).

**(L/R) TOO COLD**—The mix temperature in the freezing cylinder (barrel) has dropped below 10°F (-12°C).

**Heat Cycle Summary**

The HEAT CYCLE SUMMARY screen displays the hours since the last Heat cycle, the hours since the product temperature was above 150°F (65.6°C), and the number of heat cycles completed since the last brush clean date.

<b>HEAT CYCLE SUMMARY</b>	
<b>HRS SINCE HC</b>	0
<b>HRS SINCE 150</b>	0
<b>HC SINCE BC</b>	0

**Heat Cycle Data**

The HEAT CYCLE DATA screen contains a record of up to 366 Heat Treatment Cycles. The most recent Heat cycle data will be shown first.

Each Heat cycle record has three screens. The first screen displays the month and day of the Heat cycle, the start time and end time, and the fault description. The bottom line displays the record number and indicates if a power failure occurred during the Heat cycle (POWER FAILURE IN HC).

<b>01/01</b>	<b>HEAT TREAT CYCLE</b>	<b>02:00</b>	<b>05:14</b>
	<b>NO FAULT FOUND</b>		
			<b>1</b>

Press the Up Arrow key to advance forward through the data pages. Press the Down Arrow key to reverse the page direction.

Hopper and barrel temperature records for each side of the freezer are displayed in the second and third screens. The second screen shows the left side (L) side of the freezer.

The third screen shows the right side (R) of the freezer. The top line of these screens shows the hopper (H) and barrel (B) temperatures recorded at the end of the HEAT TREAT CYCLE and indicates the side (L or R) of the freezer.

The remaining lines indicate the following:

**HEAT** = Total time for the hopper (h) and barrel (b) to reach 150.9°F (66.1°C).

**OVER** = Total time the hopper (h) and barrel (b) temperature was above 150°F (65.6°C).

**COOL** = Total time the hopper (h) and barrel (b) temperature was above 41°F (5°C) during the Cool phase.

**PEAK** = Highest temperature reading for the hopper (h) and barrel (b) during the Heat Treatment Cycle.

<b>H: 40.9</b>	<b>B:26.3</b>	<b>L</b>
<b>HEAT</b>	<b>OVER</b>	<b>COOL</b>
<b>1:12</b>	<b>0:49</b>	<b>h 1:19</b>
<b>0:46</b>	<b>1:11</b>	<b>b 0:15</b>
		<b>161.0</b>
		<b>169.7</b>

<b>H: 38.0</b>	<b>B:23.7</b>	<b>R</b>
<b>HEAT</b>	<b>OVER</b>	<b>COOL</b>
<b>1:09</b>	<b>0:52</b>	<b>h 1:11</b>
<b>0:66</b>	<b>1:00</b>	<b>b 0:11</b>
		<b>161.2</b>
		<b>169.9</b>

The HEAT time indicates the amount of time taken in each zone to reach 150.9°F (66.1°C). Each zone must remain above 150°F (65.6°C) for a minimum of 35 minutes.

Press the Up Arrow key to advance to the next page or the Down Arrow key to view the previous page. A Heat Cycle Failure message will display on the first screen if a failure occurred.

## USER INTERFACE

Listed below are variable failure code messages which could appear on line 2.

HT	HEAT TIME FAILURE Mix temperature did not rise above 151°F (66.1°C) in less than 90 minutes.
CL	COOL MODE FAILURE Mix temperature in the hopper and freezing cylinder did not fall below 41°F (5°C) in less than 90 minutes for UVC3 units, or 120 minutes for UVC4 units.
TT	TOTAL TIME FAILURE The Heat Treatment Cycle must be completed in no more than 4 hours.
ML	MIX LOW FAILURE The Heat Phase or Cool Phase time was exceeded and a mix low condition was present.
MO	MIX OUT FAILURE A mix out condition was detected at the start or during the Heat cycle.
BO	BEATER OLVD IN HC A beater overload occurred during the Heat cycle.
PF	POWER FAILURE IN HC A power failure caused the Heat Phase, Cool Phase, or Total Cycle time to exceed the maximum allowed time. If a power failure occurs but the Heat Treatment Cycle does not fail, an asterisk(*) will appear on the third line of the display.
OP	OPERATOR INTERRUPT Indicates the Heat cycle was aborted by the OPERATOR INTERRUPT option in the Service Menu.
PS	POWER SWITCH OFF The power switch was placed into the OFF position during the Heat cycle.
TH	THERMISTOR FAILURE A thermistor probe has failed.
PD	PRODUCT DOOR OFF A product door is not in place or is loose.

## System Information

The system information is displayed on four separate screens. The first screen contains the control and software version installed in the machine.

```
SOFTWARE VERSION
C708 CONTROL UVC4
VERSION X.XX
> Next
```

Press the SEL key to advance to the next system information screen containing the software language version.

```
Language
V5.01 English
> Next
```

Press the SEL key to advance to the next screen.

```
Bootloader
V1.13.000
> Next
```

Press the SEL key to advance to the system information screen containing the model, bill of material, and machine serial number. Pressing the SEL key again will return to the menu list.

```
B.O.M. C700000000
S/N M0000000
Othr= 00000
> Next
```

## Current Conditions

The CURRENT CONDITIONS screen provides viscosity readings for the product when the machine is running, as well as the hopper and freezing cylinder temperatures for the machine.

VISC	0.0
HOPPER	41.0
BARREL	41.0

The CURRENT CONDITIONS screen is the only menu screen that will return the control panel keys to normal operation. The menu keys will not be lit when this option is selected, but the panel touch keys are fully functional. Exit the CURRENT CONDITIONS screen and return to the menu by pressing the SEL key.

## ENABLE WIFI

The ENABLE WIFI screen provides the ability to enable/disable the WIFI gateway (if the machine has the optional WIFI equipment).

Press the Up or Down arrow key to move the arrow to the appropriate selection.

Pressing the SEL key with the arrow by the appropriate selection will select that setting and return to the Manager's Menu.

Once enabled, the gateway will start broadcasting its **access point**. This will broadcast until the machine is paired with an Internet connection, or after a 10-minute time-out.



The C708 stores mix in a hopper and has a 3.4 qt. (3.2 L) capacity freezing cylinder with a single spout door. The C716 stores mix in two hoppers and has two 3.4 qt. (3.2 L) capacity freezing cylinders with a three spout door.

The model C708 has been selected to illustrate the step-by-step operating procedures. Duplicate the procedures, where they apply, for the second freezing cylinder on the Model C716.

We begin our instructions at the point where we enter the store in the morning and find the parts disassembled and laid out to air-dry from the previous night's cleaning.

These opening procedures will show you how to assemble these parts into the freezer, sanitize them, and prime the freezer with fresh mix in preparation to serve your first portion.

If you are disassembling the machine for the first time, or need information to get to this starting point in our instructions, turn to page 6-14, "Disassembly," and start there.

## Freezing Cylinder Assembly

**Note:** When lubricating parts, use an approved food grade lubricant (example: Taylor Lube).



**WARNING!** Make sure the power switch is in the OFF position. Failure to follow this instruction may result in severe personal injury from hazardous moving parts.

1. Before installing the beater driveshaft, lubricate the groove on the beater driveshaft.
2. Slide the beater driveshaft boot seal over the small end of the beater driveshaft and engage into the groove on the shaft.
3. Heavily lubricate the inside portion of the boot seal and also lubricate the flat end of the boot seal that comes in contact with the rear shell bearing.
4. Apply an even coat of lubricant to the shaft. **Do not** lubricate the hex end. (See Figure 6-1.)

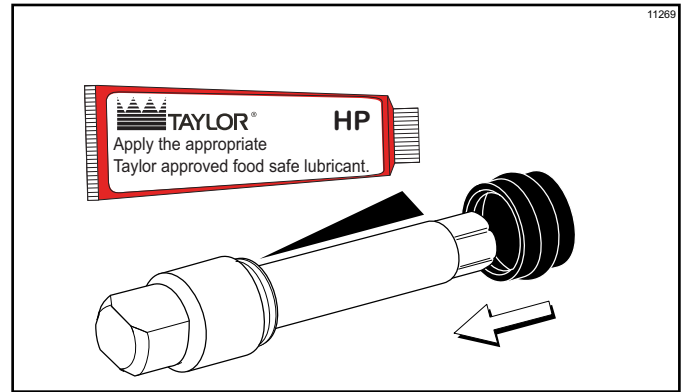

Figure 6-1

**Note:** To ensure the mix does not leak out of the back of the freezing cylinder, the middle section of the boot seal should be convex or extend out from the seal. If the middle section of the boot seal is concave or extending into the middle of the seal, turn the seal inside out.

5. Insert the beater driveshaft through the rear shell bearing in the freezing cylinder and engage the hex end firmly into the drive coupling. See Figure 6-2.

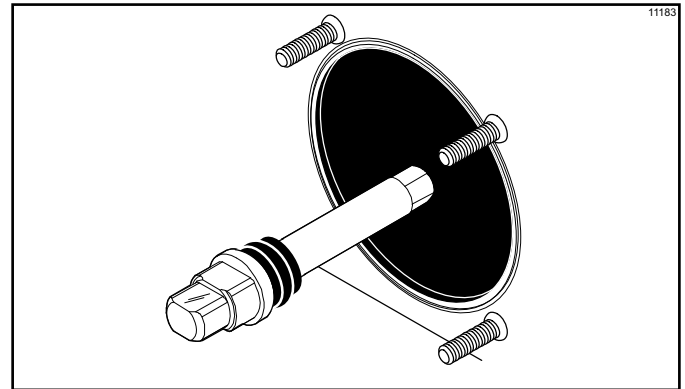

Figure 6-2



**USE EXTREME CAUTION** when handling the beater assembly. The scraper blades are very sharp and may cause injury.

6. Before installing the beater assembly, check the scraper blades. Check the scraper blades for any signs of wear or damage. If a scraper blade is nicked or worn, replace both blades.

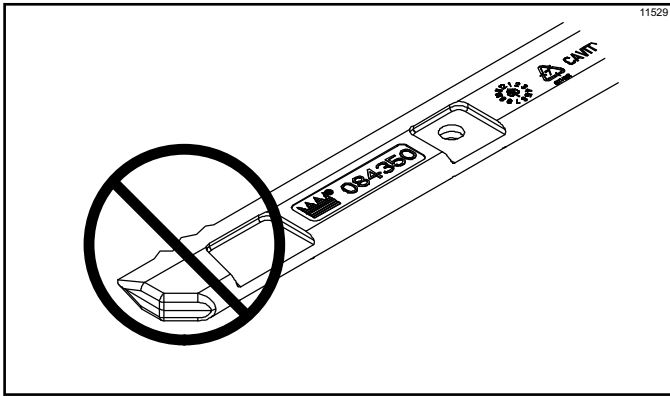

Figure 6-3

If the blades are in good condition, place the rear scraper blade over the rear holding pin on the beater.

(See Figure 6-4.)

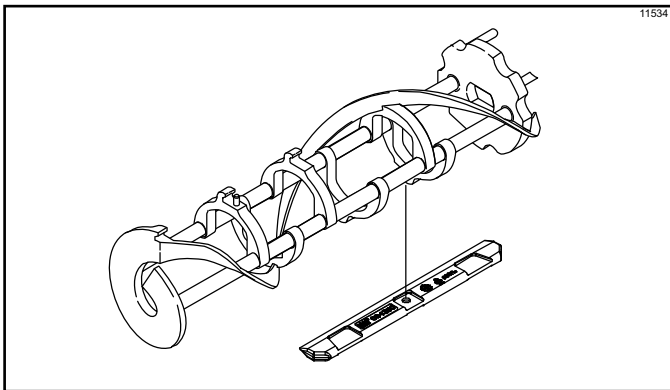

Figure 6-4

**Note:** Scraper blades should be replaced every 3 months.

**Note:** The hole on the scraper blade must fit securely over the pin to prevent costly damage.

7. Holding the rear blade on the beater, slide it into the freezing cylinder halfway. Install the front scraper blade over the front holding pin. (See Figure 6-5.)

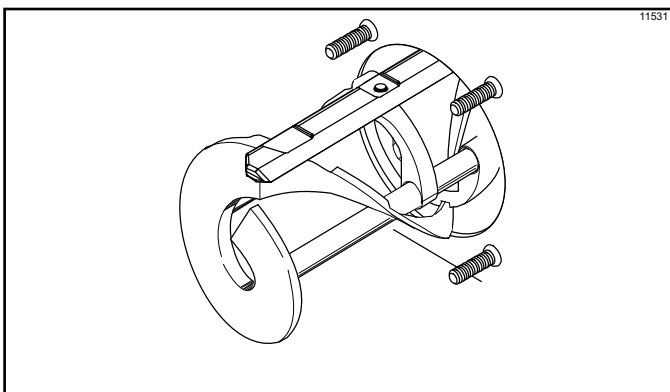

Figure 6-5

8. Before installing the beater shoes, check the shoes for any nicks, cracks, or signs of wear. If any defects are present, replace the beater shoes.
9. If the beater shoes are in good condition, install the beater shoes. (See Figure 6-6.)

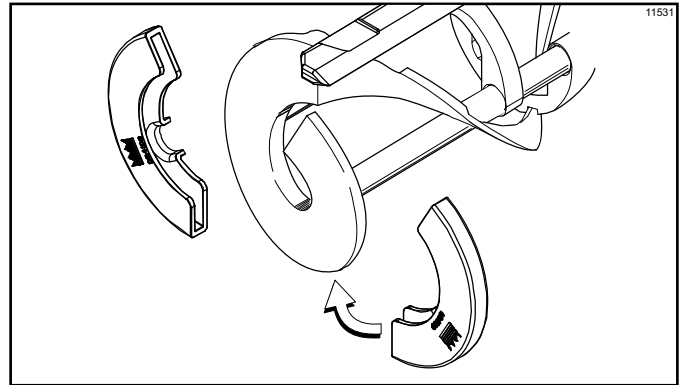

Figure 6-6

10. Slide the beater assembly the rest of the way into the freezing cylinder.

Make sure the beater assembly is in position over the driveshaft by turning the beater slightly until the beater is properly seated. When in position, the beater will not protrude beyond the front of the freezing cylinder. (See Figure 6-7.)

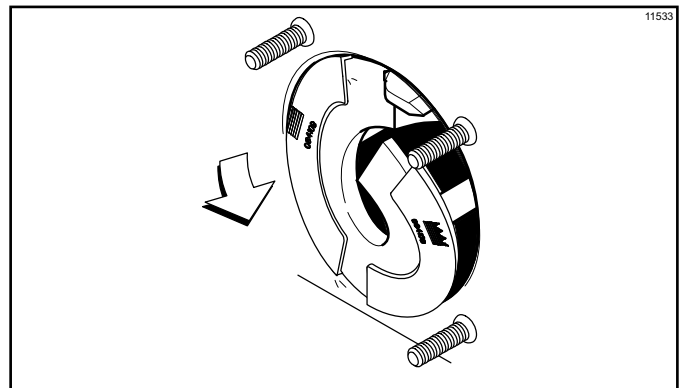

Figure 6-7

**Repeat steps 1 through 10** for the other side of the Model C716.

## Freezer Door Assembly

The assembly of the C708 freezer door is different from the C716 freezer door. Please follow the appropriate instructions for your machine.

### Model C708 Freezer Door Assembly

1. Before assembling the freezer door, check the following for any nicks, cracks, or signs of wear: door bearing, door gasket, draw valve, O-rings, and all sides of the door assembly, including the inside of the draw valve bore. Replace any damaged parts.
2. Install baffle by raising round end while engaging lug into door pocket. Lower round end to secure to door. Place the door gasket into the groove on the back of the freezer door. **Do not** lubricate the gasket or bearing. (See Figure 6-8.)

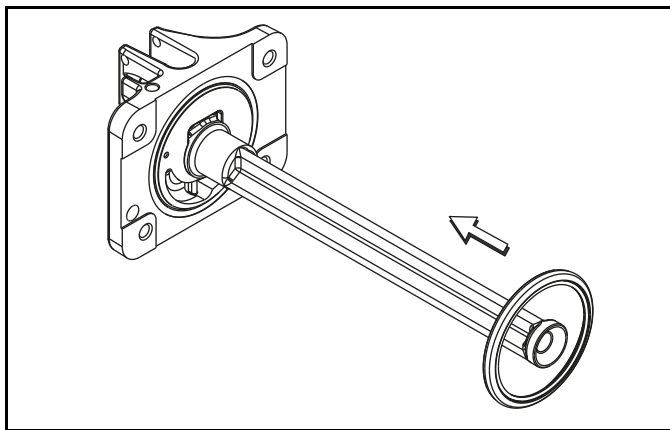

Figure 6-8

3. Slide the three O-rings into the grooves on the draw valve and lubricate. (See Figure 6-9.)

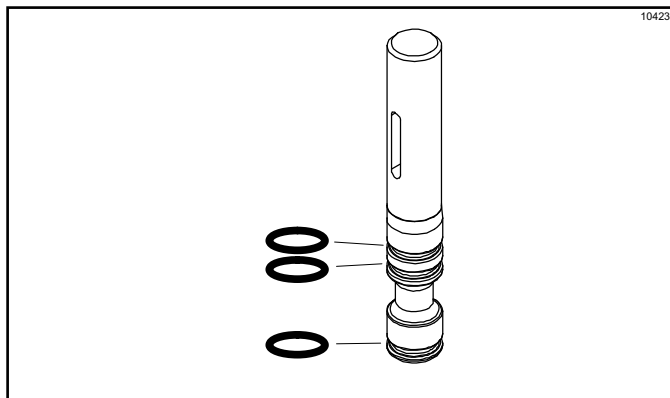

Figure 6-9

4. Lightly lubricate the inside of the top of the freezer door valve cavity. (See Figure 6-10.)

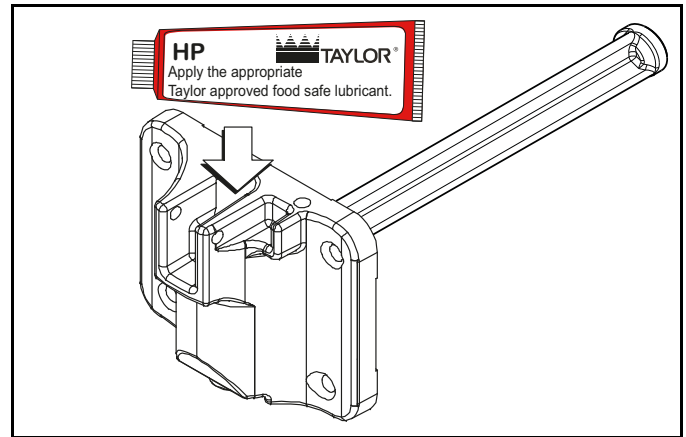

Figure 6-10

5. Insert the draw valve from the top, with the draw handle slot facing forward. (See Figure 6-11.)

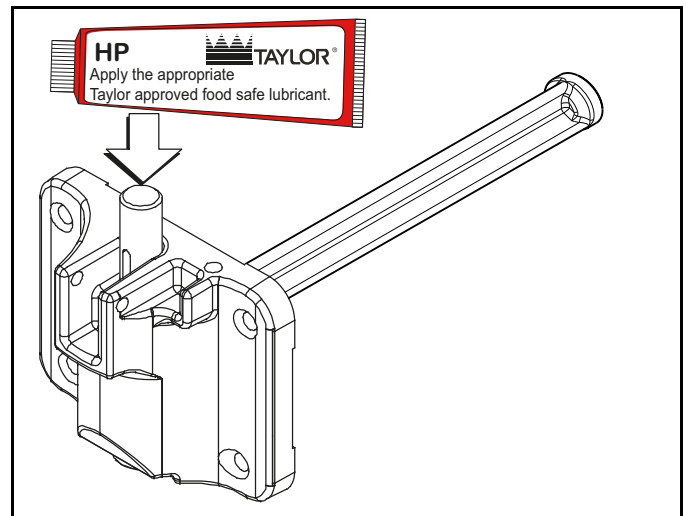

Figure 6-11

6. Insert the baffle rod through the beater in the freezing cylinder. With the door seated on the freezer studs, install the handscrews, with the longer ones on top. Tighten equally in a crisscross pattern to ensure the door is secured. (See Figure 6-12.)

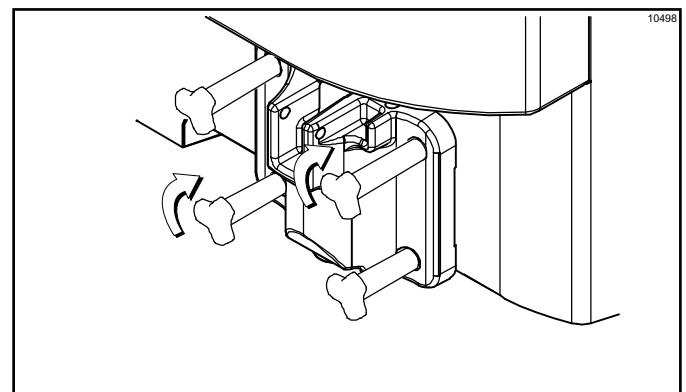

Figure 6-12

## OPERATING PROCEDURES

- Slide the fork of the draw handle into the slot of the draw valve. Secure with the pivot pin. (See Figure 6-13.)

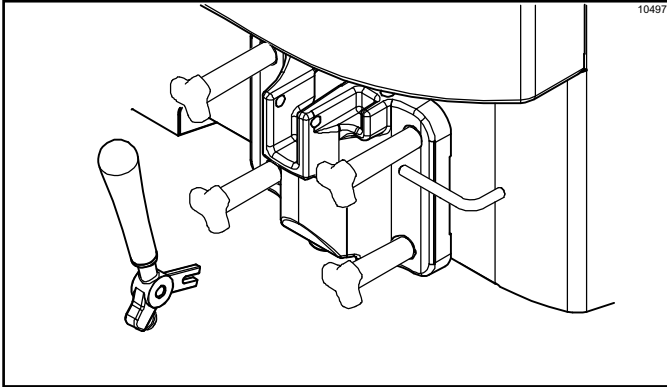

Figure 6-13

**Note:** The C708 features an adjustable draw handle to provide portion control, giving a better, more consistent quality to your product and controlling costs.

The draw handle should be adjusted to provide a flow rate of 5 oz. to 7-1/2 oz. (142 g to 213 g) of product by weight per 10 seconds. To increase the flow rate, turn the adjustment screw clockwise. Turn the adjustment screw counterclockwise to decrease the flow rate.

- Slide the two drip pans into the holes in the left and rear panels. (See Figure 6-14.)

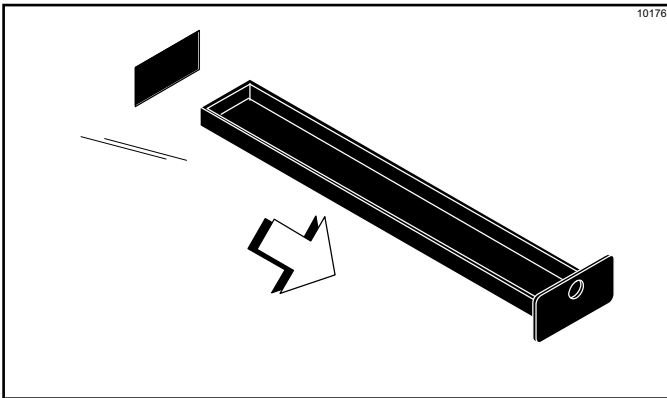

Figure 6-14

- Install the front drip tray and splash shield under the door spout. (See Figure 6-15.)

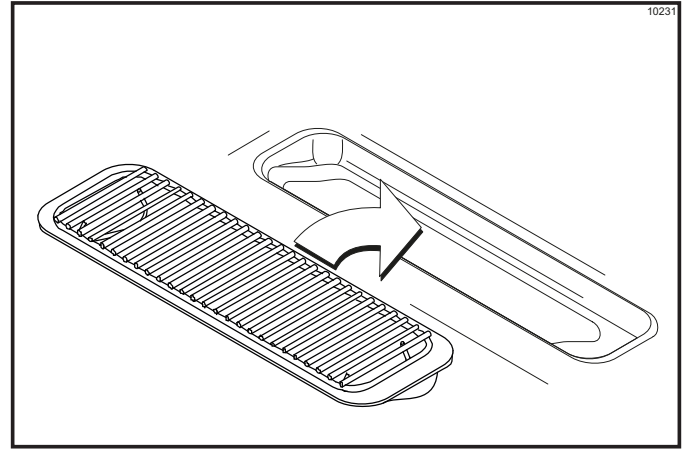

Figure 6-15

### Model C716 Freezer Door Assembly

- Before assembling the freezer door, check the following for any nicks, cracks, or signs of wear: door bearings, door gaskets, draw valves, O-rings, and all sides of the door assembly, including the inside of the draw valve bores. Replace any damaged parts.
- Install baffles by raising round ends while engaging lugs into door pockets. Lower round ends to secure to door. Place the door gaskets into the grooves on the back of the freezer door. **Do not** lubricate the gaskets.

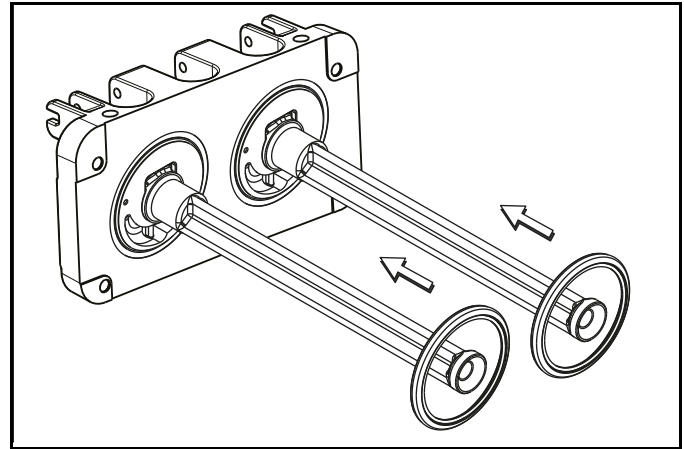

Figure 6-16

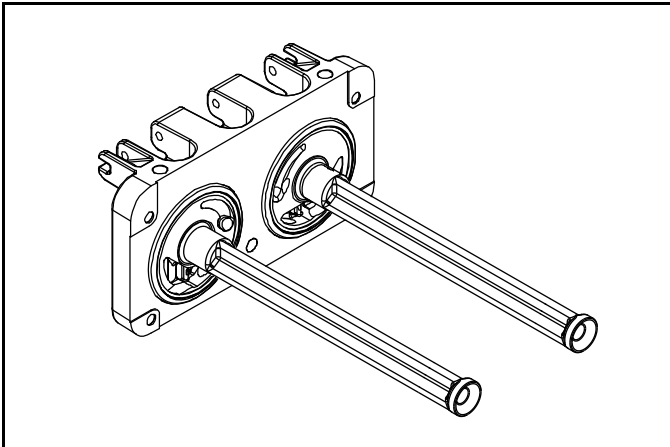

Figure 6-17

- 3. Insert the baffle rods through the beaters in the freezing cylinders. With the door seated on the freezer studs, install the handscrews with the longer ones on top. Tighten equally in a crisscross pattern to ensure the door is secured.

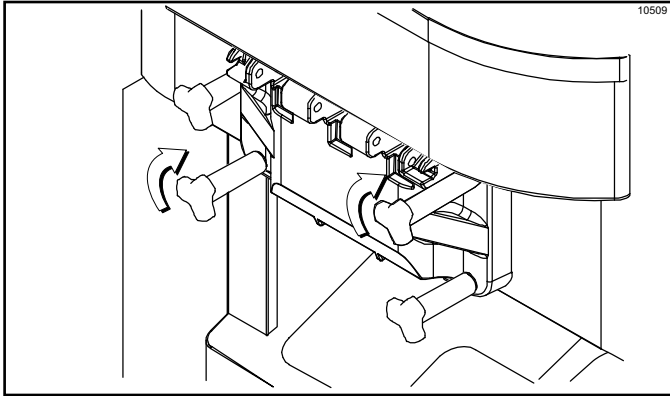

Figure 6-18

- 4. Slide the three O-rings into the grooves of each standard draw valve. Slide the H-ring and O-rings into the grooves of the center draw valve. Lubricate the H-ring and O-rings.

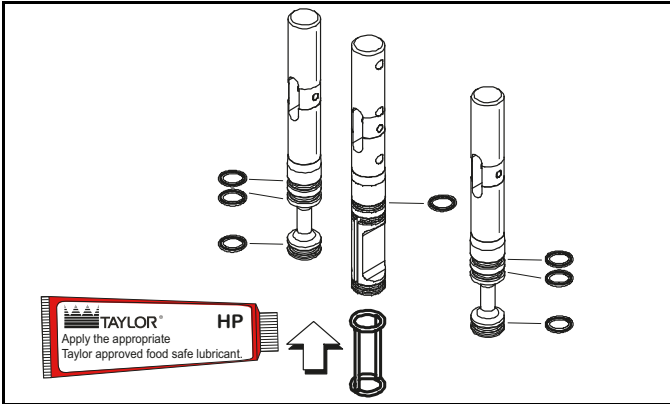

Figure 6-19

- 5. Lubricate the inside of the freezer door spouts, top and bottom.

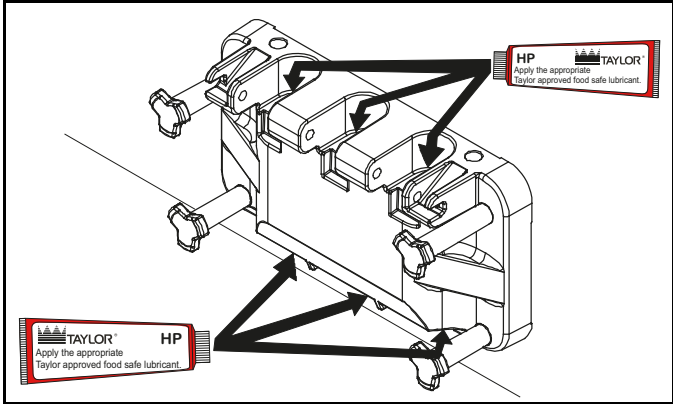

Figure 6-20

- 6. Insert the draw valves from the bottom until the slot in each draw valve comes into view.

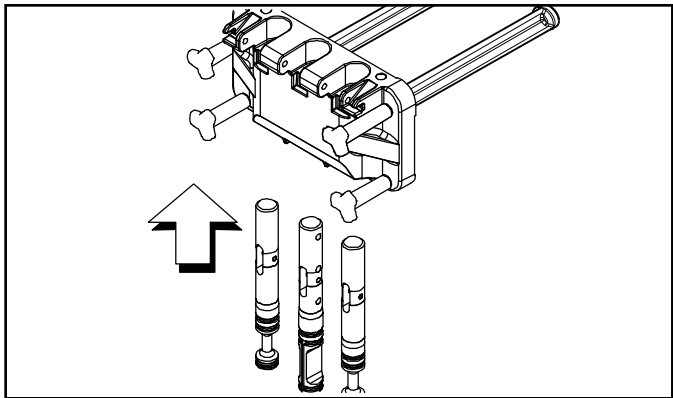

Figure 6-21

- 7. Position each draw handle with the adjustment screw facing down. Slide the fork of each draw handle into the slot of each draw valve, starting from the right.
- 8. Slide the pivot pin through the draw handles as the handles are inserted into the draw valves.

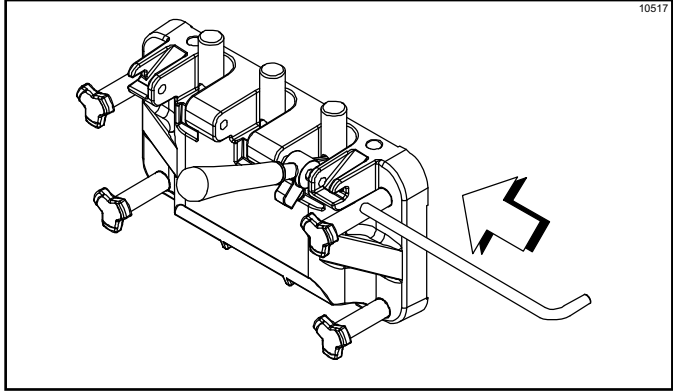

Figure 6-22

**Note:** This freezer features adjustable draw handles to provide portion control, giving a better, more consistent quality to your product and controlling costs. The draw handles should be adjusted to provide a flow rate of 5 oz. to 7-1/2 oz. (142 g to 213 g) of product by weight per 10 seconds. To increase the flow rate, turn the adjustment screw clockwise. To decrease the flow rate, turn the adjustment screw counterclockwise.

9. Snap the design caps over the bottom of the door spouts.
10. Slide the two short drip pans into the holes in the back panel. Slide the two long drip pans into the holes in the side panels. (See Figure 6-23.)

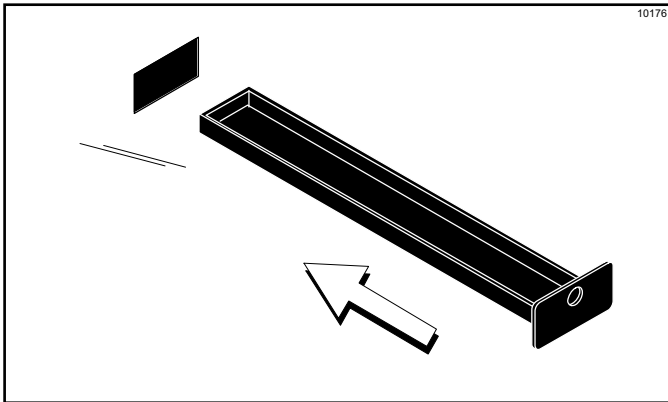

Figure 6-23

6

11. Install the front drip tray and splash shield under the door spouts. (See Figure 6-24.)

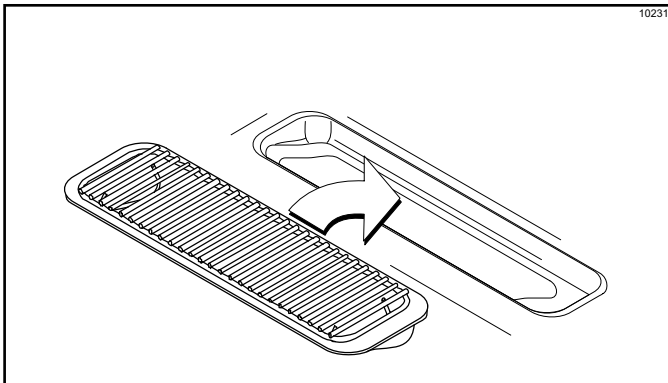

Figure 6-24

## Mix Pump Assembly

1. Inspect the rubber and plastic pump parts. The O-rings, check rings, and gaskets must be in 100% good condition for the pump and entire machine to operate properly. They cannot properly serve their intended function if nicks, cuts, or holes in the material are present.

Inspect the plastic pump parts for cracks, wear, and delamination of plastic.

Replace any defective parts immediately and discard the old.

2. Assemble the piston. Slide the red O-ring into the groove of the piston. **Do not** lubricate the O-ring. (See Figure 6-25.)

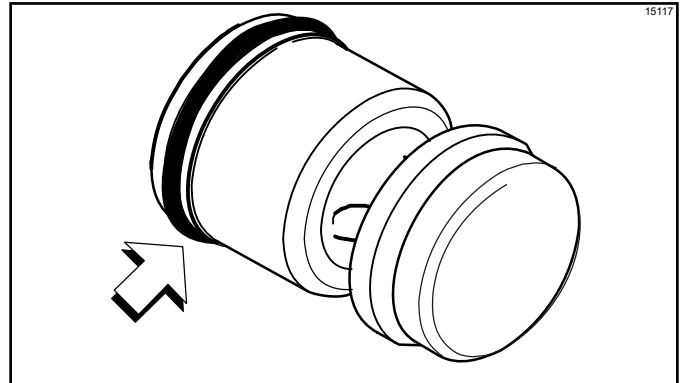

Figure 6-25

3. Apply a thin layer of lubricant to the inside of the pump cylinder at the retaining pin hole end. (See Figure 6-26.)

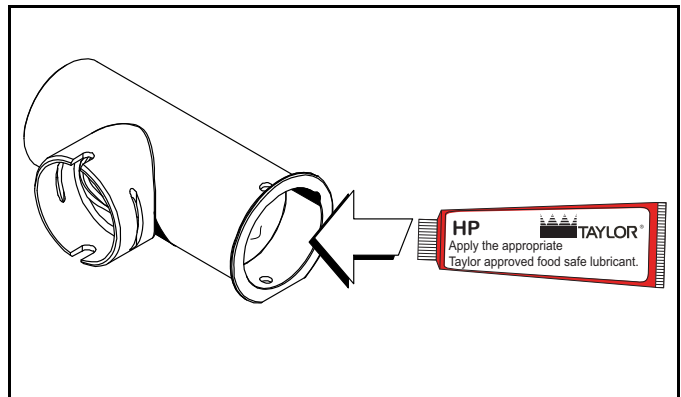

Figure 6-26

4. Insert the piston into the retaining pin hole end of the pump cylinder. (See Figure 6-27.)

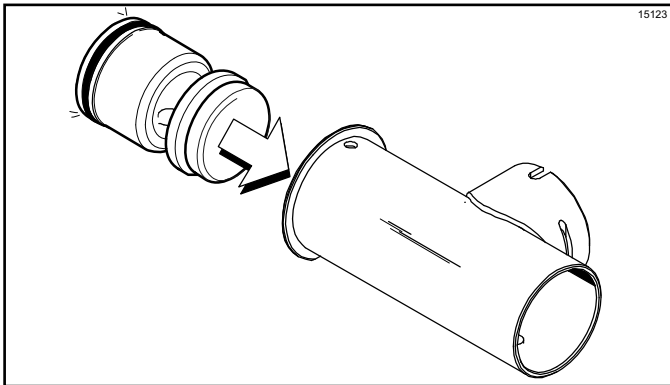

Figure 6-27

5. Assemble the valve cap. Slide the O-ring into the groove of the valve cap. **Do not** lubricate the O-ring. (See Figure 6-28.)

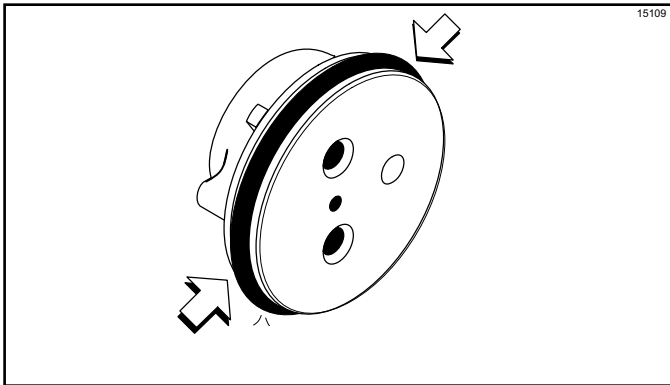

Figure 6-28

6. Slide the pump valve gasket into the holes on the cap. **Do not** lubricate the gasket. (See Figure 6-29.)

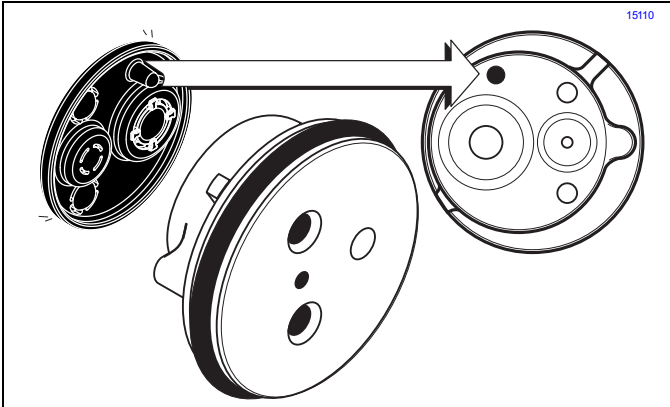

Figure 6-29

7. Insert the valve body cap into the hole in the mix inlet adapter. (See Figure 6-30.)

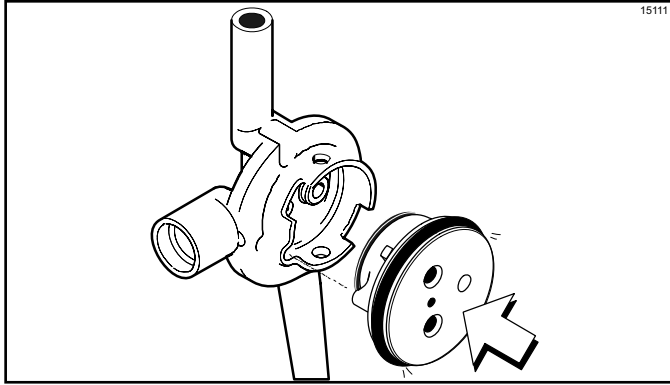

Figure 6-30

8. Insert the mix inlet assembly into the pump cylinder. (See Figure 6-31.)

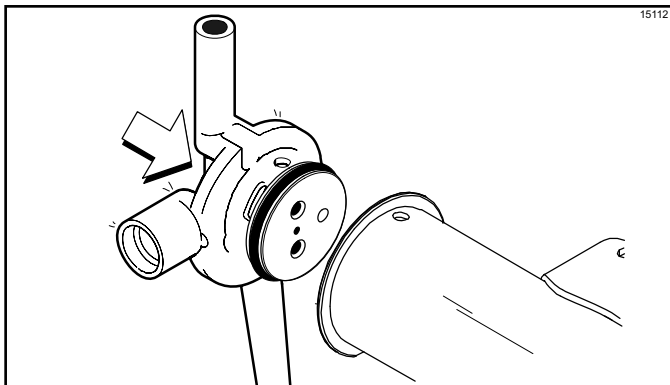

Figure 6-31

The adapter must be positioned into the notch located at the end of the pump cylinder.

9. Secure the pump parts in position by sliding the retaining pin through the cross holes located at one end of the pump cylinder. (See Figure 6-32.)

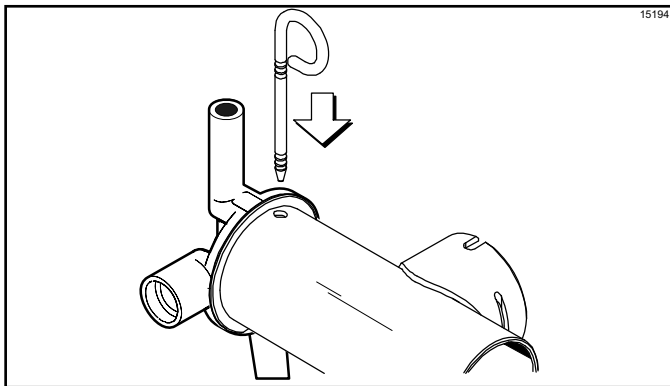

Figure 6-32

**Note:** The head of the retaining pin should be located at the top of the pump when installed.

## OPERATING PROCEDURES

10. Assemble the feed tube assembly. Slide the check ring into the groove of the feed tube.  
(See Figure 6-33.)

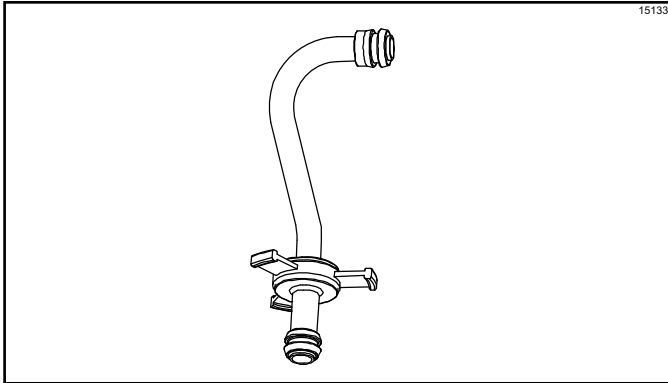

Figure 6-33

11. Install one red O-ring on each end of the mix feed tube and thoroughly lubricate. (See Figure 6-34.)

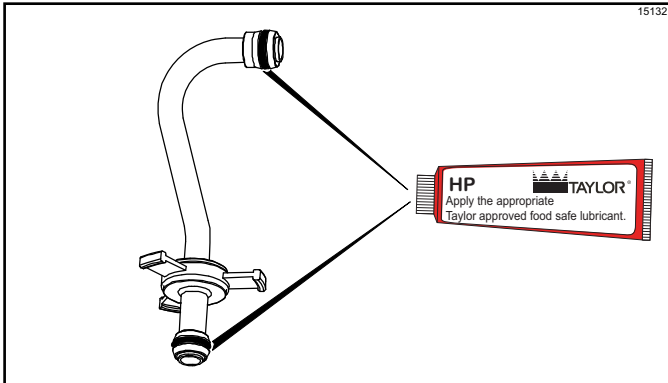

Figure 6-34

12. Lay the pump assembly, pump clip, cotter pin, mix feed tube assembly, and agitator in the bottom of the mix hopper for sanitizing. (See Figure 6-35.)

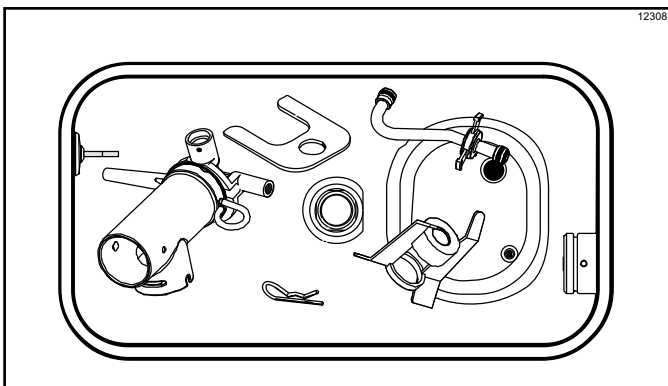

Figure 6-35

13. Slide the large black O-ring and the two smaller black O-rings into the grooves on the driveshaft. Thoroughly lubricate the O-rings and shaft. **Do not** lubricate the hex end of the shaft. (See Figure 6-36.)

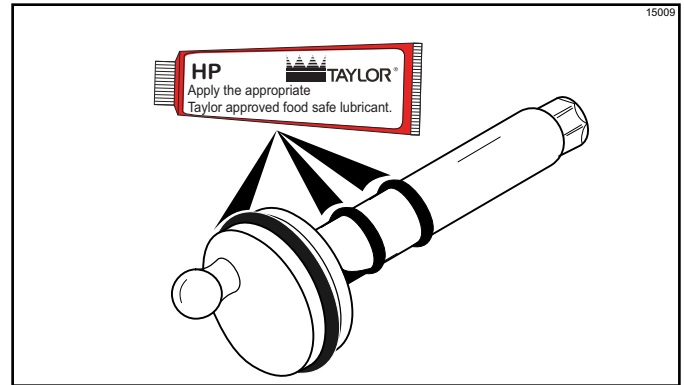

Figure 6-36

14. Install the hex end of the driveshaft into the drive hub at the rear wall of the mix hopper. (See Figure 6-37.)

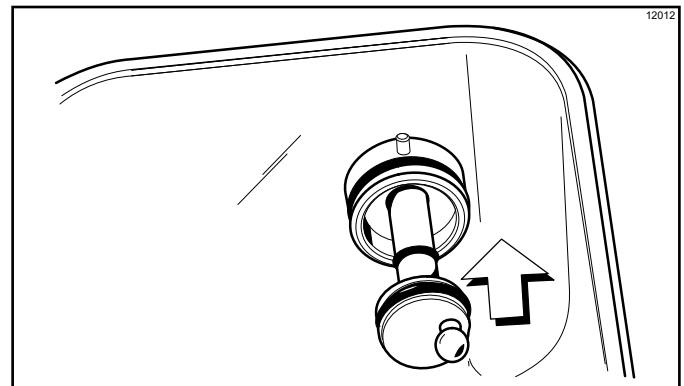

Figure 6-37

**Note:** For ease in installing the pump, position the ball crank of the driveshaft in the 3 o'clock position.

**Repeat steps 1 through 14** for the other side of the Model C716.

## Sanitizing

1. Prepare an approved 100 PPM sanitizing solution (examples: 2-1/2 gal. [9.5 L] of Kay-5<sup>®</sup> or 2 gal. [7.6 L] of Stera-Sheen<sup>®</sup>).

**Important!** Use warm water and follow the manufacturer's specifications.

2. Pour the sanitizing solution over all the parts in the bottom of the mix hopper and allow it to flow into the freezing cylinder. (See Figure 6-38.)

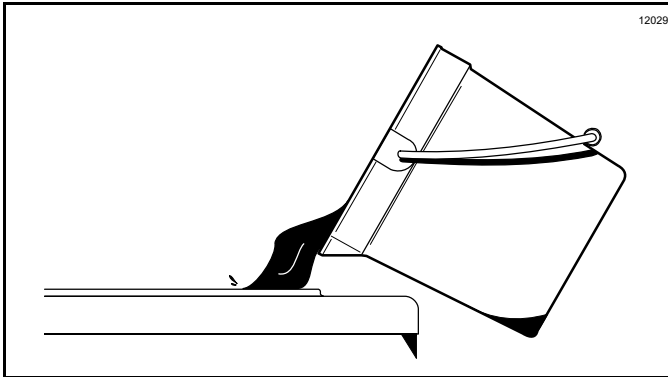

Figure 6-38

**Note:** You have just sanitized the mix hopper and parts; therefore, make sure your hands are clean and sanitized before continuing in these instructions.

3. While the solution is flowing into the freezing cylinder, take particular care to brush-clean the mix-level sensing probe on the bottom of the hopper, the mix hopper, the mix inlet hole, the air/mix pump, the pump clip, the mix feed tube, and the locking clip.
4. Install the pump assembly at the rear of the mix hopper. To position the pump on the drive hub, align the drive hole in the piston with the drive crank of the driveshaft. Secure the pump in place by slipping the pump clip over the collar of the pump, making sure the clip fits into the grooves in the collar. (See Figure 6-39.)

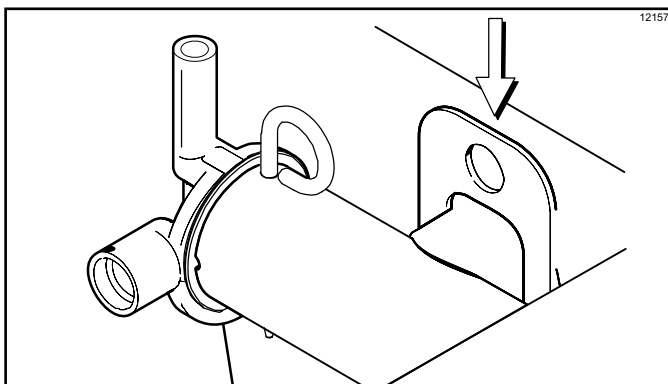

Figure 6-39



**IMPORTANT!** Ensure the cotter pin is installed in the pump end of the mix feed tube. Failure to follow this instruction could result in sanitizer spraying on the operator.

5. Install the pump end of mix feed tube and secure with cotter pin. (See Figure 6-40.)

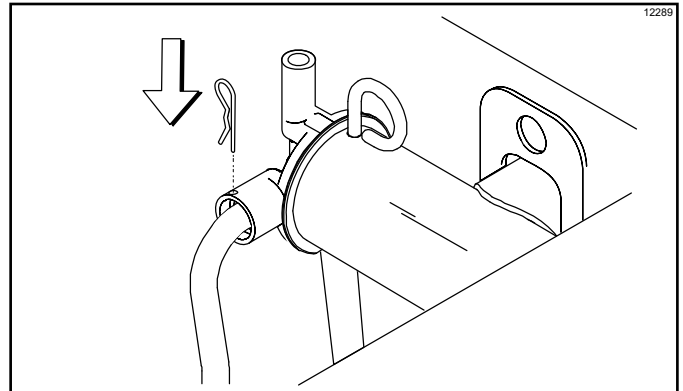





Figure 6-40

6. Prepare another pail of approved 100 PPM sanitizing solution (examples: 2-1/2 gal. [9.5 L] of Kay-5<sup>®</sup> or 2 gal. [7.6 L] of Stera-Sheen<sup>®</sup>).

**Important!** Use warm water and follow the manufacturer's specifications.

7. Pour the sanitizing solution into the mix hopper.
  8. Brush the exposed sides of the hopper.
  9. Place the power switch in the ON position.
  10. Press the Wash key . This will cause the sanitizing solution in the freezing cylinder to be agitated. Wait at least 5 minutes before proceeding with these instructions.
  11. With a pail beneath the door spout(s), open the draw valve and press the Pump key . Open and close the draw valve 6 times.
- Note:** Momentarily open the center draw valve to sanitize the center door spout (C716 only).
12. Draw off the remaining sanitizing solution.

13. Press the Wash and Pump keys   and close the draw valve. (See Figure 6-41.)

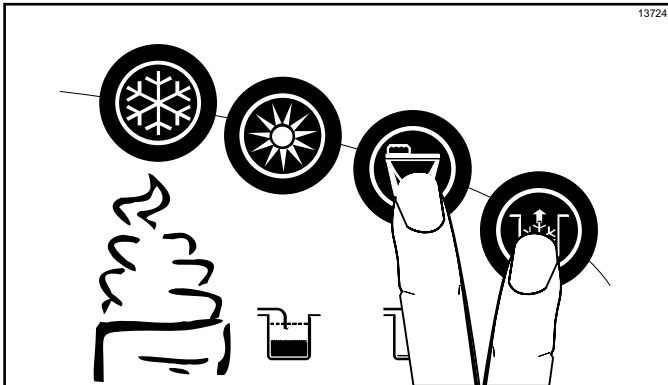

Figure 6-41

**Important!** The machine must **not** be placed in Auto mode until all sanitizing solution has been removed from the freezing cylinder and proper priming procedures have been completed. Failure to follow this instruction may result in damage to the freezing cylinder.

**Note:** Make sure your hands are clean and sanitized before continuing with these instructions.

14. Place the agitator on the agitator driveshaft housing. (See Figure 6-42.)

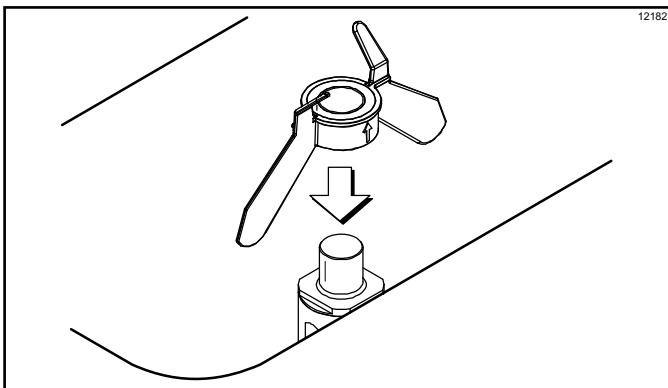

Figure 6-42

**Note:** If agitator should stop turning during normal operation, with **sanitized hands**, remove agitator from agitator driveshaft housing and brush-clean with sanitizing solution. Install the agitator back onto the agitator driveshaft housing.

15. Remove the cotter pin from the pump. Remove the feed tube and position it as shown in the illustration below. Place the cotter pin in position on the outlet fitting of the pump assembly. (See Figure 6-43.)

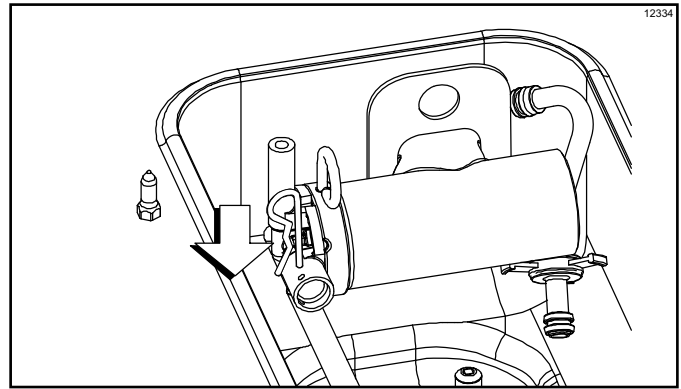

Figure 6-43

Repeat steps 1 through 15 for the other side of the Model C716.

## Priming

**Note:** Use only **fresh** mix when priming the freezer.

1. Place an empty pail beneath the door spout(s). Pour 2-1/2 gal. (9.5 L) of **fresh** mix into the mix hopper and allow it to flow into the freezing cylinder.
2. Open the draw valve to remove all sanitizing solution. When only **fresh** mix is flowing, close the draw valve.

**Note:** Momentarily open the center draw valve to remove sanitizer from the center door spout (C716 only).

**Important!** Failure to remove all sanitizing solution may result in damage to the freezing cylinder.

3. When mix stops bubbling down into the freezing cylinder, remove the cotter pin from the outlet fitting of the mix pump. Insert the outlet end of the mix feed tube into the mix inlet hole in the mix hopper. Place the inlet end of the mix feed tube into the outlet fitting of the mix pump. Secure with cotter pin.

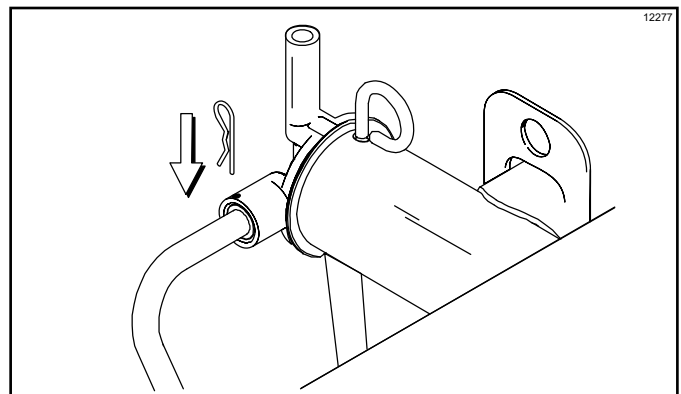

Figure 6-44

4. Select the Auto key ❄️.
5. Fill the hopper with **fresh** mix and place the mix hopper cover in position.

**Repeat steps 1 through 5** for the other side of the Model C716.

## Daily Closing Procedures

**This procedure must be performed once daily.**

The function of the Heat Treatment Cycle is to destroy bacteria by raising the temperature of the mix in the freezing cylinder and the hopper to a specified temperature for a specified period of time, and then bringing the temperature back down low enough to retard spoilage.

The Heat Treatment Cycle will start at the time designated in the Auto Heat Time.

**Important!** The level of mix in the hoppers must be high enough to cover the agitator paddles.

**Note:** If the BRUSH CLEAN COUNTER display has counted down to 1 day, do not add mix. The machine must be disassembled and brush-cleaned within 24 hours.

The freezer must be in the Auto mode (Auto key ❄️ illuminated) or Standby mode (Standby key ❄️/⏸ illuminated) before the Heat cycle can be started.

1. Remove the hopper cover(s).
  - Note:** Make sure your hands are clean and sanitized before performing these next steps.
2. Remove the agitator(s) from the mix hopper(s).
3. Remove the design caps (C716 only).
4. Take the agitator(s), hopper cover(s), and design cap(s) to the sink for further cleaning and sanitizing.
5. Rinse these parts in cool, clean water.
6. Prepare a small amount of an approved 100 PPM cleaning/sanitizing solution (example: Kay-5® or Stera-Sheen®). Use warm water and follow the manufacturer's specifications.
  - a. Brush-clean the agitator(s) and the hopper cover(s).
  - b. Sanitize the agitator(s) and hopper cover(s).

7. Install the agitator(s) back onto the agitator drive shaft housing(s). Replace the hopper cover(s).

**Important!** Make sure the agitator(s) are installed and the switch is in the Auto or Standby mode. Otherwise, the machine will not have a successful Heat cycle.

8. Return to the freezer with a small amount of cleaning solution. Dip the door-spout brush into the cleaning solution and brush-clean the door spout(s) and bottom of the draw valve(s).

**Note:** To ensure sanitary conditions are maintained, brush each item for 60 seconds, repeatedly dipping the brush in cleaning solution. (See Figure 6-45.)

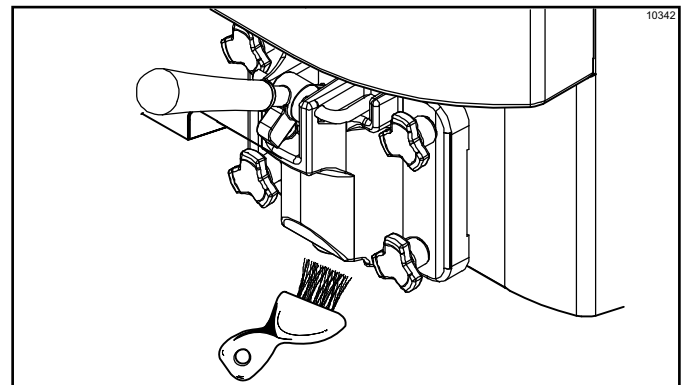

Figure 6-45

9. Remove, clean, and reinstall all drip pans. (See Figure 6-46.)

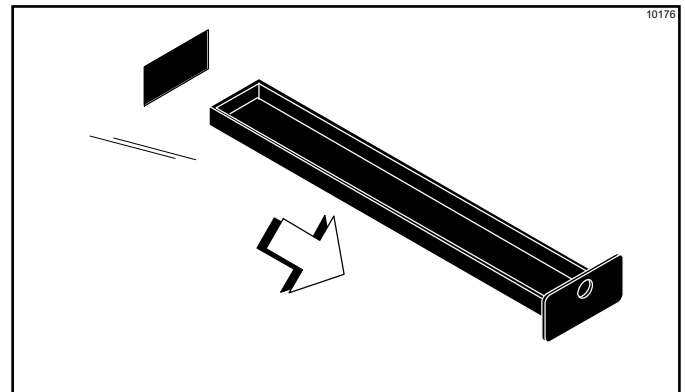



Figure 6-46

10. Using a clean, sanitized towel, wipe down the freezer door, front panel, the area around the bottom of the freezer door, and any other areas that have a buildup of either moisture or food substance.

The Heat cycle will start when the clock on the machine reaches the Auto Heat Time set in the Manager's Menu (See page 5-10).

There are three phases of the Heat cycle: Heating, Holding, and Cooling. Each phase has a time limit. If any one of the three phases fails to reach the proper temperatures within the time limit, the cycle will automatically abort and return to the Standby mode.

A failure message will appear on the fluorescent display to inform the operator that the machine did not successfully complete the Heat Treatment Cycle. The product may not be safe to serve. The freezer will be locked out (soft lock) of the Auto mode. The operator will be given the option of selecting the Heat

key , which will begin a new Heat cycle, or

pressing the Wash key , which will place the freezer into the Off mode to allow a brush-clean of the machine.

**Note:** Once the heating cycle has started, it cannot be interrupted. The heating cycle will take a maximum of 4 hours to complete with full hoppers.



**CAUTION! DO NOT** attempt to draw product or disassemble the machine during the Heat cycle. The product is hot and under extreme pressure, which can cause injuries.

6

When the Heat cycle is complete, the control will

return to the Standby mode. The Standby key(s)  will be illuminated.

## Daily Opening Procedures

Before performing the opening procedures, check the display panel for any error messages. Normally, the display is blank unless an operational fault has occurred. If a fault has been detected, investigate the cause and follow the instructions on the display before proceeding with the opening procedures. (See Failure Messages, starting on page 5-12.)

## Setup—Complete The Following

**Important!** Make sure your hands are clean and sanitized before performing these next steps.

1. Prepare a small amount of an approved 100 PPM sanitizing solution (example: Kay-5® or Stera-Sheen®). Use warm water and follow the manufacturer's specifications.
2. Return to the freezer with a small amount of sanitizing solution. Dip the door-spout brush into the sanitizing solution and brush-clean the door spout(s) and bottom of the draw valve(s). (See Figure 6-47.)

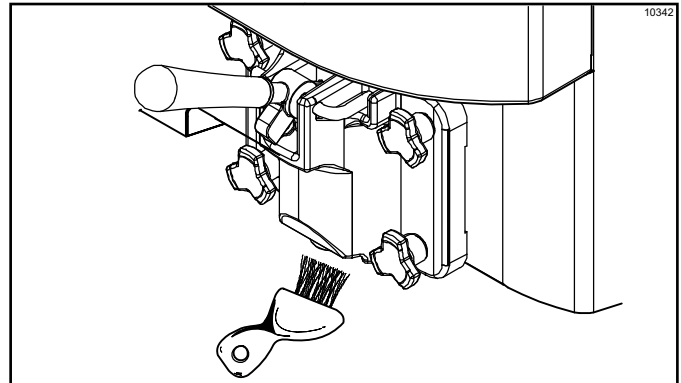



Figure 6-47

**Note:** To ensure sanitary conditions are maintained, brush-clean each item for 60 seconds, repeatedly dipping the brush in sanitizing solution.

3. Using a clean, sanitized towel, wipe down the freezer door, front panel, the area around the bottom of the freezer door, and any other areas that show a buildup of either moisture or food substance. Install the front drip tray and splash shield.

**Note:** Install the design caps (C716 only).

4. When ready to resume normal operation, press the Auto key . (See Figure 6-48.)

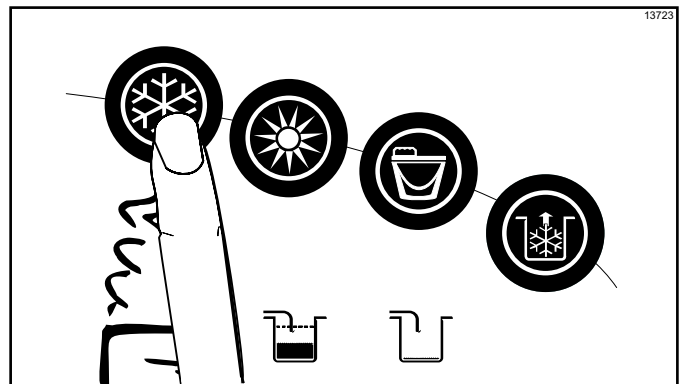

Figure 6-48

The control has a feature in the Manager's Menu to enable or disable the Auto Start feature. When Auto Start is enabled, the machine will automatically exit the Standby mode and start the machine in the Auto mode at a designated time each day. (See page 5-10.)

**Note:** This procedure should be performed 15 minutes prior to serving product.

### Manual Brush-Cleaning

These procedures must be completed according to the frequency specified by your federal, state, or local regulatory agencies. Please consult your governing food code to determine the maximum number of days allowed between brush-clean cycles.





To disassemble these machines, the following items will be needed:

- Two cleaning and sanitizing pails
- Sanitizer/Cleaner
- Cleaning brushes (provided with freezer)
- Single-service towels

### Draining Product From The Freezing Cylinder

1. With a pail beneath the door spout(s), open the draw valve.

Press the Wash and Pump keys   . (See Figure 6-49.)

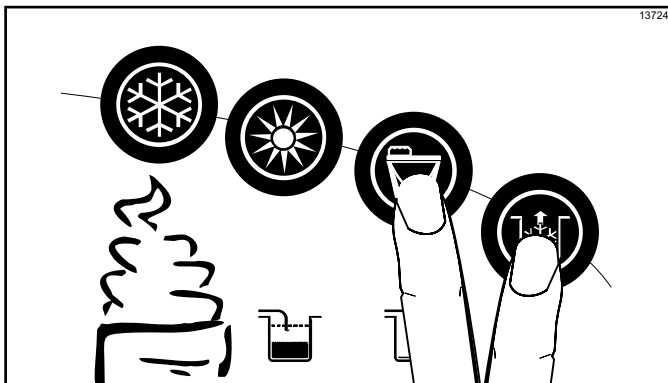



Figure 6-49

**Note:** Do not allow the pump to keep running when the draw valve is closed. Excessive pressure will build up, causing product to spurt out when the draw valve is opened.

2. Drain the product from the freezing cylinder and the mix hopper.
3. When the flow of product stops, press the Wash and Pump keys   , canceling the Wash and Pump modes. Close the draw valve. Properly dispose of the mix. (See Figure 6-50.)

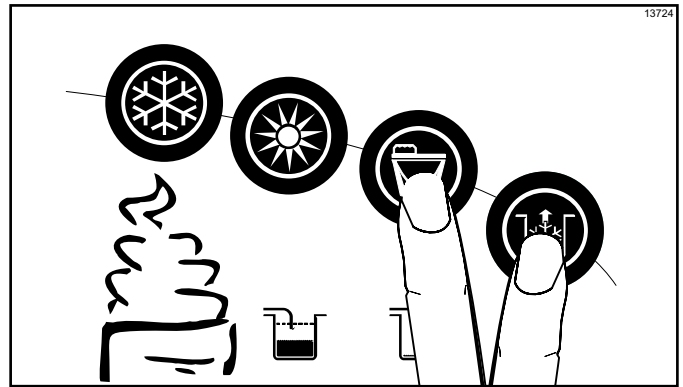

Figure 6-50

4. Remove the locking clip, mix feed tube, pump clip, and the assembled air/mix pump.

Repeat steps 1 through 4 for the other side of the Model C716.

### Rinsing

1. Pour 2 gal. (7.6 L) of cool, clean water into the mix hopper. With the white hopper brush, scrub the mix hopper, mix-level sensing probe, and the outside of the agitator driveshaft housing. Using the double-ended brush, brush-clean the mix inlet hole. (See Figure 6-51.)

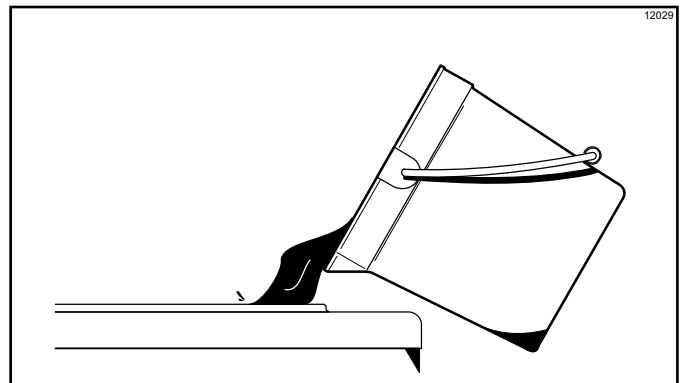



Figure 6-51

## OPERATING PROCEDURES

**Note:** Do not brush-clean the mix inlet hole while the machine is in the Wash mode.

2. With a pail beneath the door spout(s), open the draw valve and press the Wash key . (See Figure 6-52.)

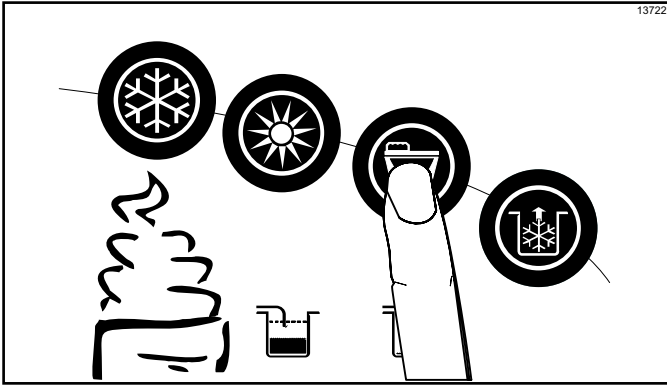



Figure 6-52



3. Drain all the rinse water from the door spout. Close the draw valve and press the Wash key,  canceling the Wash mode.
4. Repeat this procedure using clean, warm water, until the water being discharged is clear.

Repeat steps 1 through 4 for the other side of the Model C716.

6

### Hopper Cleaning

1. Prepare an approved 100 PPM cleaning solution (examples: 2-1/2 gal. [9.5 L] of Kay-5<sup>®</sup> or 2 gal. [7.6 L] of Stera-Sheen<sup>®</sup>).  
**Important!** Use warm water and follow the manufacturer's specifications.
2. Pour the solution into the hopper and allow it to flow into the freezing cylinder.
3. Using the white hopper brush, clean the mix hopper, mix-level sensing probes, and the outside of the agitator driveshaft housing. Using the double-ended brush, clean the mix inlet hole. (**Note:** Do not brush-clean the mix inlet hole while the machine is in the Wash mode.)

4. Press the Wash key . This will cause the cleaning solution in the freezing cylinder to come in contact with all areas of the freezing cylinder.
5. Place an empty pail beneath the door spout(s).
6. Open the draw valve on the freezer door and draw off all the solution.
7. Once the cleaning solution stops flowing from the door spout, close the draw valve and press the Wash key , canceling the Wash mode.

Repeat steps 1 through 7 on the other side of the Model C716.

### Disassembly

**Note:** Failure to remove the parts specified below for brush-cleaning and lubrication will result in damage to the machine. These parts must be removed within the maximum number of days allowed between brush-clean cycles or the machine will hard lock and will not operate.



**WARNING!** Make sure the power switch is in the OFF position. Failure to follow this instruction may result in severe personal injury from hazardous moving parts.

1. Remove the handscrews, freezer door, beater, scraper blades, and driveshaft with driveshaft seal from the freezing cylinder.
2. Remove the driveshaft seal from the driveshaft.
3. Remove the retaining pin, mix inlet adaptor, valve cap, pump gasket, and piston from the pump cylinder. Remove the O-ring from the piston and valve cap.
4. Remove the freezer door gasket, front bearing, pivot pin, draw handle, and draw valve. Remove the three O-rings from the draw valve.

**Note:** Remove the design caps (C716 only).

- Remove the pump driveshaft from the drive hub in the rear wall of the mix hopper. (See Figure 6-53.)

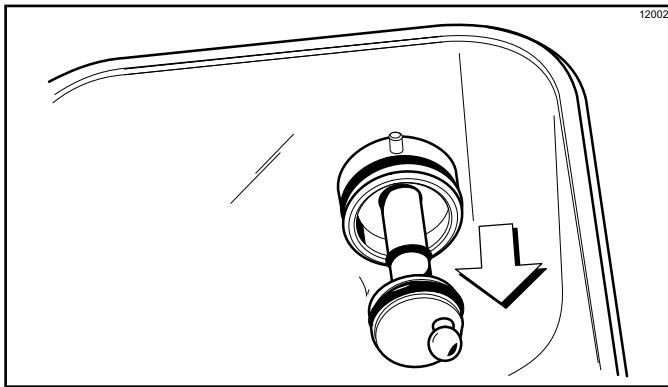

Figure 6-53

- Remove the two small O-rings and one large O-ring from the pump driveshaft.

**Repeat steps 1 through 5** on the other side of the Model C716.

- Remove the front drip tray and splash shield.
- Remove all drip pans. Take them to the sink for cleaning. (See Figure 6-54.)

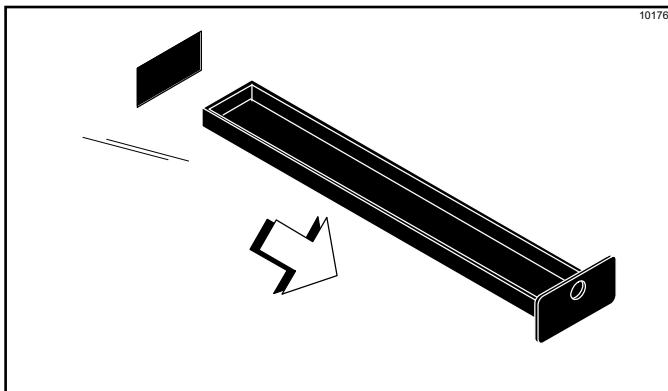

Figure 6-54

**Note:** If the drip pans are filled with an excessive amount of mix, it is an indication that the driveshaft seal(s) or O-ring(s) should be replaced or properly lubricated.

### Brush-Cleaning

- Prepare an approved 100 PPM cleaning solution (examples: 2-1/2 gal. [9.5 L] of Kay-5® or 2 gal. [7.6 L] of Stera-Sheen®).

**Important!** Use warm water and follow the manufacturer's specifications.

Make sure all brushes provided with the freezer are available for brush-cleaning.

- Thoroughly brush-clean all disassembled parts in the cleaning solution, making sure all lubricant and mix film is removed. Make sure to brush all surfaces and holes, especially the holes in the pump components and the draw valve hole in the freezer door. Rinse all parts with clean, warm water. Place the parts on a clean, dry surface to air-dry overnight.
- Return to the freezer with a small amount of cleaning solution. Using the black brush, clean the rear shell bearing at the back of the freezing cylinder. (See Figure 6-55.)

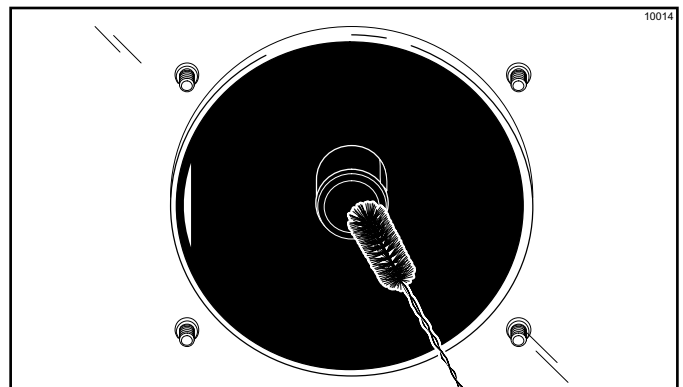

Figure 6-55

- Using the black brush, clean the drive hub opening in the rear wall of the mix hopper. (See Figure 6-56.)

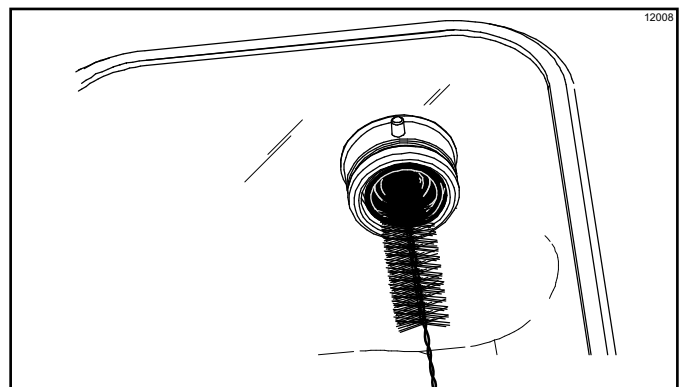

Figure 6-56

**Repeat steps 1 through 4** on the other side of the Model C716.

- Wipe all exterior surfaces of the freezer with a clean, sanitized towel.



## During Cleaning and Sanitizing



**NOTICE!** Cleaning and sanitizing schedules are governed by your federal, state, or local regulatory agencies and must be followed accordingly. Please see the cleaning section of this manual for the proper procedure to clean this machine.

**Important!** We recommend cleaning and sanitizing every 120 days.

## Troubleshooting Bacterial Count

- Thoroughly clean and sanitize the machine regularly, including complete disassembly and brush-cleaning
- Use all brushes supplied for thorough cleaning. The brushes are specially designed to reach all mix passageways.
- Use the bristle brush to clean the mix inlet hole, which extends from the mix hopper down to the rear of the freezing cylinder.
- Use the black-bristle brush to thoroughly clean the rear shell bearing at the rear of the freezing cylinder and the drive hub opening in the rear wall of the mix hopper. Use a generous amount of cleaning solution on the brush.
- Properly prepare the cleaning and sanitizing solutions. Read and follow the label directions carefully. Too **strong** of a solution may damage the parts, and too **weak** of a solution will not do an adequate job of cleaning or sanitizing.
- The temperature of the mix in the mix hopper and walk-in cooler should be below 40°F (4.4°C).
- Discard remaining mix from the freezer during cleaning procedures.

## Regular Maintenance Checks

- Replace scraper blades that are nicked or damaged. Before installing the beater assembly, make sure the scraper blades are properly attached to the helix.
- Check the rear shell bearing for signs of wear (excessive mix leakage in rear drip pan) and make sure it is properly cleaned.
- Using a screwdriver and cloth towel, clean the rear shell bearing and the female hex drive socket free of lubricant and mix deposits.
- Dispose of O-rings and seals if they are worn, torn or fit too loosely, and replace with new ones.
- Follow all lubricating procedures as outlined in Assembly.
- If your machine is air-cooled, check the condensers for dirt and lint. Dirty condensers will reduce the efficiency and capacity of the machine. Condensers should be cleaned monthly with a soft brush. Never use screwdrivers or other metal probes to clean between the fins.
- Caution: Always disconnect electrical power prior to cleaning the condenser. Failure to follow this instruction may result in electrocution.
- If your machine is water-cooled, check the water lines for kinks or leaks. Kinks can occur when the machine is moved back and forth for cleaning or maintenance purposes. Deteriorated or cracked water lines should be replaced only by an authorized Taylor distributor.

**Note:** For machines equipped with an air filter, it will be necessary to vacuum clean the filters on a monthly schedule.

### Winter Storage

If the place of business is to be closed during the winter months, it is important to protect the freezer by following certain precautions, particularly if the building is to be left unheated and subject to freezing conditions.

Disconnect the freezer from the main power source to prevent possible electrical damage.

On water-cooled freezers, disconnect the water supply. Relieve pressure on the spring in the water valve. Use air pressure on the outlet side to blow out any water remaining in the condenser.

**Important!** Failure to follow this procedure may cause severe and costly damage to the refrigeration system.

Your local Taylor distributor can perform this winter storage service for you.

Wrap detachable parts of the freezer (such as the beater, scraper blades, driveshaft, and freezer door) and place them in a protected, dry place. Rubber trim parts and gaskets can be protected by wrapping them with moisture-proof paper. All parts should be thoroughly cleaned of dried mix or lubrication, which can attract mice and other vermin.

**Note:** *It is recommended that an authorized service technician perform winter storage draining to ensure all water has been removed. This will guard against freezing and rupturing of the components.*

Table 8-1

Problem	Probable Cause	Remedy	Page Ref.
1. Soft lock message appears on display.	a. More than 24 hours since the last Heat cycle.	a. The freezer must go through a Heat cycle every 24 hours. The freezer must now be disassembled and brush-cleaned or placed in a Heat cycle.	5-6
	b. The power switch is in the OFF position.	b. The power switch must be in the ON position. The freezer must now be disassembled and brush-cleaned or placed in a Heat cycle.	5-6
	c. The freezer was not in the Auto or Standby mode when the Heat cycle was programmed to start.	c. The freezer must be in the Auto or Standby mode. The freezer must now be disassembled and brush-cleaned or placed in a Heat cycle.	5-6
	d. Mix out or mix low condition.	d. The level of mix in the mix hopper must be above the mix low probe. The freezer must now be disassembled and brush-cleaned or placed in a Heat cycle.	5-6
	e. The agitator is not installed.	e. The agitator must be cleaned and installed before starting the Heat cycle. The freezer must now be disassembled and brush-cleaned or placed in a Heat cycle.	6-11
	f. There was a power failure.	f. Check fault messages and product temperature. Disassemble and brush-clean, or initiate a Heat Treatment Cycle.	5-12
2. Hard lock message appears on display.	a. Brush-clean interval exceeded.	a. The freezer must be disassembled and brush-cleaned within 24 hours when the counter indicates one day remaining.	5-5
	b. A barrel or hopper thermistor is faulty.	b. Call an authorized service technician.	---
3. No control panel functions with power switch in ON position.	a. Machine is unplugged.	a. Plug into wall receptacle.	---
	b. Circuit breaker off or blown fuse.	b. Turn the breaker on or replace the fuse.	---
4. Machine makes a squealing noise.	a. Starved barrel.	a. Remove, clean, and reinstall the pump.	6-6/ 6-9/ 6-15

## TROUBLESHOOTING GUIDE

Problem	Probable Cause	Remedy	Page Ref.
5. No product is being dispensed.	a. Low on mix. The MIX OUT light is on.	a. Add mix to the hopper. Return to Auto mode.	6-10
	b. The power switch is in the OFF position.	b. Place the power switch to ON position and select Auto mode.	6-10
	c. Machine not in Auto mode.	c. Select Auto mode and allow machine to cycle off before drawing product.	6-10
	d. Beater motor is out on reset. BEATER OVERLOAD message is displayed.	d. Turn the machine off. Press the reset button. Restart the machine in Auto mode.	---
	e. The pump motor is not running in the Auto mode.	e. Push the pump reset button. Check that the pump motor is operating when the draw valve is raised.	5-3
	f. Freeze-up in the mix inlet hole.	f. Call an authorized service technician.	---
	g. The mix pump ball crank is broken.	g. Call an authorized service technician.	---
	h. Feed tube or check ring not properly installed.	h. Make sure feed tube and rubber check ring are properly installed.	6-8,6-10
6. The product is too soft.	a. Draw rate is set too fast.	a. Adjust draw rate of 5 oz. to 7-1/2 oz. (142 g to 213 g) of product by weight in 10 seconds.	5-3
7. The product is too thick.	a. Freezing cylinder not primed correctly.	a. Drain the freezing cylinder and reprime the machine.	6-10
	b. Air/mix pump incorrectly assembled.	b. Follow assembly procedures carefully.	6-6
	c. The viscosity control is set too cold.	c. Call an authorized service technician.	---
	d. Freeze-up in mix inlet hole.	d. Call an authorized service technician.	---
	e. Butterfat is in the pump.	e. Disassemble, clean, and reinstall the pump.	6-6, 6-9, 6-15
8. The mix in the hopper is too warm.	a. Hopper cover is not in position.	a. Clean and sanitize the hopper cover and place in position.	6-11
	b. The agitator is not installed.	b. Clean and sanitize the agitator and install.	6-11
	c. The hopper temperature is out of adjustment.	c. Call an authorized service technician.	---
9. The mix in the hopper is too cold.	a. The hopper temperature is out of adjustment.	a. Call an authorized service technician.	---
10. Mix Low and Mix Out probes are not functioning.	a. Milkstone buildup in the hopper.	a. Clean hoppers thoroughly.	6-15
11. Product is collecting on top of the freezer door.	a. The top O-ring on the draw valve is improperly lubricated or worn.	a. Lubricate properly or replace the O-ring.	6-6
12. Excessive mix leakage from the bottom of door spout.	a. Bottom O-ring on draw valve is improperly lubricated or worn.	a. Lubricate properly or replace the O-ring.	6-6

<b>Problem</b>	<b>Probable Cause</b>	<b>Remedy</b>	<b>Page Ref.</b>
13.Excessive mix leakage into the long drip pan.	a. Driveshaft seal improperly lubricated or worn.	a. Lubricate properly or replace the seal.	6-1
	b. Driveshaft seal is installed inside-out.	b. Install correctly.	6-1
	c. Inadequate lubrication of the driveshaft.	c. Lubricate properly.	6-1
	d. The driveshaft and beater assembly work forward.	d. Call an authorized service technician.	---
	e. Worn rear shell bearing.	e. Call an authorized service technician.	---
	f. Gearbox out of alignment.	f. Call an authorized service technician.	---
14.The driveshaft is stuck in the drive coupling.	a. Mix and lubricant collected in drive coupling.	a. Brush-clean the rear shell bearing area regularly.	6-15
	b. Rounded corners of driveshaft, drive coupling, or both.	b. Call an authorized service technician.	---
	c. Gearbox is out of alignment.	c. Call an authorized service technician.	---
15.The freezing cylinder walls are scored.	a. Missing or worn front bearing and beater shoes.	a. Install or replace the front bearing and beater shoes.	6-2,6-4
	b. Scraper blades are damaged.	b. Replace scraper blades.	6-2
	c. Machine was placed in Auto before all sanitizing solution was removed from freezing cylinder.	c. Place machine in Auto only after priming is complete and all sanitizing solution is removed.	6-9/6-10
	d. Broken freezer door baffle rod.	d. Replace freezer door.	6-4
	e. Broken beater pins.	e. Replace beater assembly.	6-2
	f. Beater assembly is bent.	f. Replace beater assembly.	6-2
	g. Machine was placed in Auto before all sanitizing solution was removed from freezing cylinder.	g. Place machine in Auto only after priming is complete and all sanitizing solution is removed.	6-9/6-10
	h. Gearbox is out of alignment.	h. Call an authorized service technician.	---
16.The product makes a popping sound when drawn.	a. Draw rate is set too fast.	a. Adjust draw rate of 5 oz. to 7-1/2 oz. (142 g to 213 g) of product by weight in 10 seconds.	5-3
	b. Pump assembled incorrectly.	b. Assemble and lubricate according to instructions in this manual.	6-6
	c. Freezing cylinder not primed correctly.	c. Drain the freezing cylinder and reprime the machine.	6-10



# Section 9

# Parts Replacement Schedule

Table 9-1

Part Description	Every 3 Months	Every 6 Months	Annually	Every 4 Years
Door A.				X
Scraper Blade	X			
Driveshaft Seal	X			
Freezer Door Gasket	X			
Front Bearing	X			
Front Beater Shoes	X			
Draw Valve O-ring	X			
Mix Feed Tube O-ring	X			
Pump O-ring	X			
Pump Valve Gasket	X			
Mix Feed Tube Check Ring	X			
Pump Driveshaft O-ring	X			
Brush, 3" x 7"		Inspect and replace if necessary.	Minimum	
Brush, 3" x 1/2"		Inspect and replace if necessary.	Minimum	
Brush, 1-1/2" x 3"		Inspect and replace if necessary.	Minimum	
Brush, 1" x 2"		Inspect and replace if necessary.	Minimum	
Black Bristle Brush, 1" x 2"		Inspect and replace if necessary.	Minimum	
Double-Ended Brush		Inspect and replace if necessary.	Minimum	
Yellow Bristle Brush		Inspect and replace if necessary.	Minimum	
Brush Set (3)		Inspect and replace if necessary.	Minimum	
Baffle-Threadless Molded		Inspect and replace if necessary.		



## TAYLOR COMPANY LIMITED WARRANTY ON FREEZERS

Taylor Company is pleased to provide this limited warranty on new Taylor-branded freezer equipment available from Taylor to the market generally (the "Product") to the original purchaser only.

### LIMITED WARRANTY

Taylor warrants the Product against failure due to defect in materials or workmanship under normal use and service as follows. All warranty periods begin on the date of original Product installation. If a part fails due to defect during the applicable warranty period, Taylor, through an authorized Taylor distributor or service agency, will provide a new or remanufactured part, at Taylor's option, to replace the failed defective part at no charge for the part. Except as otherwise stated herein, these are Taylor's exclusive obligations under this limited warranty for a Product failure. This limited warranty is subject to all provisions, conditions, limitations, and exclusions listed below and on the reverse (if any) of this document.

Table 10-1

Product	Part	Limited Warranty Period
Soft Serve	Insulated shell assembly	Five (5) years
Frozen Yogurt Shakes	Refrigeration compressor (except service valve)	Five (5) years
Smoothies	Beater motors	Two (2) years
Frozen Beverage	Beater drive gear	Two (2) years
Batch Desserts	Printed circuit boards and Softech controls beginning with serial number H8024200	Two (2) years
	Parts not otherwise listed in this table or excluded below	One (1) years

### LIMITED WARRANTY CONDITIONS

1. If the date of original installation of the Product cannot be verified, then the limited warranty period begins ninety (90) days from the date of Product manufacture (as indicated by the Product serial number). Proof of purchase may be required at time of service.
2. This limited warranty is valid only if the Product is installed and all required service work on the Product is performed by an authorized Taylor distributor or service agency, and only if genuine, new Taylor parts are used.
3. Installation, use, care, and maintenance must be normal and in accordance with all instructions contained in the Taylor Operator's Manual.
4. Defective parts must be returned to the authorized Taylor distributor or service agency for credit.
5. The use of any refrigerant other than that specified on the Product's data label will void this limited warranty.

### LIMITED WARRANTY EXCEPTIONS

This limited warranty does **not** cover:

1. Labor or other costs incurred for diagnosing, repairing, removing, installing, shipping, servicing, or handling of defective parts, replacement parts, or new Products.
2. Normal maintenance, cleaning, and lubrication as outlined in the Taylor Operator's Manual, including cleaning of condensers.
3. Replacement of wear items designated as Class "000" parts in the Taylor Operator's Manual.

## LIMITED WARRANTY ON EQUIPMENT

---

4. External hoses, electrical power supplies, and machine grounding.
5. Parts not supplied or designated by Taylor, or damages resulting from their use.
6. Return trips or waiting time required because a service technician is prevented from beginning warranty service work promptly upon arrival.
7. Failure, damage, or repairs due to faulty installation, misapplication, abuse, no or improper servicing, unauthorized alteration, or improper operation or use as indicated in the Taylor Operator's Manual, including but not limited to the failure to use proper assembly and cleaning techniques, tools, or approved cleaning supplies.
8. Failure, damage, or repairs due to theft, vandalism, wind, rain, flood, high water, water, lightning, earthquake, or any other natural disaster, fire, corrosive environments, insect or rodent infestation, or other casualty, accident or condition beyond the reasonable control of Taylor; operation above or below the electrical or water supply specification of the Product; or components repaired or altered in any way so as, in the judgment of the Manufacturer, to adversely affect performance, or normal wear or deterioration.
9. Any Product purchased over the Internet.
10. Failure to start due to voltage conditions, blown fuses, open circuit breakers, or damages due to the inadequacy or interruption of electrical service.
11. Electricity or fuel costs, or increases in electricity or fuel costs from any reason whatsoever.
12. Damages resulting from the use of any refrigerant other than that specified on the Product's data label will void this limited warranty.
13. Any cost to replace, refill, or dispose of refrigerant, including the cost of refrigerant.
14. **ANY SPECIAL, INDIRECT, OR CONSEQUENTIAL PROPERTY OR COMMERCIAL DAMAGE OF ANY NATURE WHATSOEVER.** Some jurisdictions do not allow the exclusion of incidental or consequential damages, so this limitation may not apply to you.

This limited warranty gives you specific legal rights, and you may also have other rights which vary from jurisdiction to jurisdiction.

### LIMITATION OF WARRANTY

**THIS LIMITED WARRANTY IS EXCLUSIVE AND IS IN LIEU OF ALL OTHER WARRANTIES, CONDITIONS, AND/OR REMEDIES UNDER THE LAW, INCLUDING ANY IMPLIED WARRANTIES OR CONDITIONS OF MERCHANTABILITY OR FITNESS FOR A PARTICULAR PURPOSE. THE ORIGINAL OWNER'S SOLE REMEDY WITH RESPECT TO ANY PRODUCTS SHALL BE REPAIR OR REPLACEMENT OF DEFECTIVE COMPONENTS UNDER THE TERMS OF THIS LIMITED WARRANTY. ALL RIGHTS TO CONSEQUENTIAL OR INCIDENTAL DAMAGES (INCLUDING CLAIMS FOR LOST SALES, LOST PROFITS, PRODUCT LOSS, PROPERTY DAMAGES, OR SERVICE EXPENSES) ARE EXPRESSLY EXCLUDED. THE EXPRESS WARRANTIES MADE IN THIS LIMITED WARRANTY MAY NOT BE ALTERED, ENLARGED, OR CHANGED BY ANY DISTRIBUTOR, DEALER, OR OTHER PERSON, WHATSOEVER.**

### LEGAL REMEDIES

The owner **must** notify Taylor in writing, by certified or registered letter to the following address, of any defect or complaint with the Product, stating the defect or complaint and a specific request for repair, replacement, or other correction of the Product under warranty, mailed at least thirty (30) days before pursuing any legal rights or remedies.

Taylor Company  
750 N. Blackhawk Blvd.  
Rockton, IL 61072, U.S.A.

## TAYLOR COMPANY LIMITED WARRANTY ON TAYLOR GENUINE PARTS

Taylor Company is pleased to provide this limited warranty on new Taylor genuine replacement components and parts available from Taylor to the market generally (the "Parts") to the original purchaser only.

### LIMITED WARRANTY

Taylor warrants the Parts against failure due to defect in materials or workmanship under normal use and service as follows. All warranty periods begin on the date of original installation of the Part in the Taylor unit. If a Part fails due to defect during the applicable warranty period, Taylor, through an authorized Taylor distributor or service agency, will provide a new or remanufactured Part, at Taylor's option, to replace the failed defective Part at no charge for the Part. Except as otherwise stated herein, these are Taylor's exclusive obligations under this limited warranty for a Part failure. This limited warranty is subject to all provisions, conditions, limitations, and exclusions listed below and on the reverse (if any) of this document.

Table 11-1

Parts Warranty Class Code Or Part	Limited Warranty Period
Class 103 Parts <sup>1</sup>	Three (3) Months
Class 212 Parts <sup>2</sup>	Twelve (12) Months
Class 512 Parts	Twelve (12) Months
Class 000 Parts	No Warranty

### LIMITED WARRANTY CONDITIONS

1. If the date of original installation of the Part cannot be otherwise verified, proof of purchase may be required at time of service.
2. This limited warranty is valid only if the Part is installed and all required service work in connection with the Part is performed by an authorized Taylor distributor or service agency.
3. The limited warranty applies only to Parts remaining in use by their original owner at their original installation location in the unit of original installation.
4. Installation, use, care, and maintenance must be normal and in accordance with all instructions contained in the Taylor Operator's Manual.
5. Defective Parts must be returned to the authorized Taylor distributor or service agency for credit.
6. This warranty is not intended to shorten the length of any warranty coverage provided pursuant to a separate Taylor Limited Warranty on freezer or grill equipment.
7. The use of any refrigerant other than that specified for the unit in which the Part is installed will void this limited warranty.

<sup>1, 2</sup> Except that Taylor Part #032129SER2 (Compressor-Air-230V SERV) and Taylor Part #075506SER1 (Compressor-Air-115V 60HZ) shall have a limited warranty period of twelve (12) months when used in Taylor freezer equipment and a limited warranty period of two (2) years when used in Taylor grill equipment.

## LIMITED WARRANTY ON PARTS

---

### LIMITED WARRANTY EXCEPTIONS

This limited warranty does **not** cover:

1. Labor or other costs incurred for diagnosing, repairing, removing, installing, shipping, servicing, or handling of defective Parts, replacement Parts, or new Parts.
2. Normal maintenance, cleaning, and lubrication as outlined in the Taylor Operator's Manual, including cleaning of condensers or carbon and grease buildup.
3. Required service, whether cleaning or general repairs, to return the cooking surface assemblies, including the upper platen and lower plate, to an operational condition to achieve proper cooking or allow proper assembly of release sheets and clips as a result of grease buildup on the cooking surfaces, including but not limited to the platen and plate, sides of the shroud, or top of the shroud.
4. Replacement of cooking surfaces, including the upper platen and lower plate, due to pitting or corrosion (or in the case of the upper platen, due to loss of plating) as a result of damage due to the impact of spatulas or other small wares used during the cooking process or as a result of the use of cleaners, cleaning materials, or cleaning processes not approved for use by Taylor.
5. Replacement of wear items designated as Class "000" Parts in the Taylor Operator's Manual, as well as any release sheets and clips for the Product's upper platen assembly.
6. External hoses, electrical power supplies, and machine grounding.
7. Parts not supplied or designated by Taylor, or damages resulting from their use.
8. Return trips or waiting time required because a service technician is prevented from beginning warranty service work promptly upon arrival.
9. Failure, damage, or repairs due to faulty installation, misapplication, abuse, no or improper servicing, unauthorized alteration, or improper operation or use as indicated in the Taylor Operator's Manual, including but not limited to the failure to use proper assembly and cleaning techniques, tools, or approved cleaning supplies.
10. Failure, damage, or repairs due to theft, vandalism, wind, rain, flood, high water, water, lightning, earthquake, or any other natural disaster, fire, corrosive environments, insect or rodent infestation, or other casualty, accident or condition beyond the reasonable control of Taylor; operation above or below the gas, electrical, or water supply specification of the unit in which a part is installed; or Parts or the units in which they are installed repaired or altered in any way so as, in the judgment of Taylor, to adversely affect performance, or normal wear or deterioration.
11. Any Part purchased over the Internet.
12. Failure to start due to voltage conditions, blown fuses, open circuit breakers, or damages due to the inadequacy or interruption of electrical service.
13. Electricity, gas, or other fuel costs, or increases in electricity or fuel costs from any reason whatsoever.
14. Damages resulting from the use of any refrigerant other than that specified for the unit in which the Part is installed will void this limited warranty.
15. Any cost to replace, refill, or dispose of refrigerant, including the cost of refrigerant.
16. **ANY SPECIAL, INDIRECT, OR CONSEQUENTIAL PROPERTY OR COMMERCIAL DAMAGE OF ANY NATURE WHATSOEVER.** Some jurisdictions do not allow the exclusion of incidental or consequential damages, so this limitation may not apply to you.

This limited warranty gives you specific legal rights, and you may also have other rights which vary from jurisdiction to jurisdiction.

**LIMITATION OF WARRANTY**

**THIS LIMITED WARRANTY IS EXCLUSIVE AND IS IN LIEU OF ALL OTHER WARRANTIES, CONDITIONS, AND/OR REMEDIES UNDER THE LAW, INCLUDING ANY IMPLIED WARRANTIES OR CONDITIONS OF MERCHANTABILITY OR FITNESS FOR A PARTICULAR PURPOSE. THE ORIGINAL OWNER'S SOLE REMEDY WITH RESPECT TO ANY PRODUCTS SHALL BE REPAIR OR REPLACEMENT OF DEFECTIVE PARTS UNDER THE TERMS OF THIS LIMITED WARRANTY. ALL RIGHTS TO CONSEQUENTIAL OR INCIDENTAL DAMAGES (INCLUDING CLAIMS FOR LOST SALES, LOST PROFITS, PRODUCT LOSS, PROPERTY DAMAGES, OR SERVICE EXPENSES) ARE EXPRESSLY EXCLUDED. THE EXPRESS WARRANTIES MADE IN THIS LIMITED WARRANTY MAY NOT BE ALTERED, ENLARGED, OR CHANGED BY ANY DISTRIBUTOR, DEALER, OR OTHER PERSON, WHATSOEVER.**

**LEGAL REMEDIES**

The owner **must** notify Taylor in writing, by certified or registered letter to the following address, of any defect or complaint with the Part, stating the defect or complaint and a specific request for repair, replacement, or other correction of the Part under warranty, mailed at least thirty (30) days before pursuing any legal rights or remedies.

Taylor Company  
750 N. Blackhawk Blvd.  
Rockton, IL 61072, U.S.A.

