

OPERATOR'S MANUAL



Model C709 and C717 Heat Treatment Soft Serve Freezers

Original Operating Instructions

062080-M

2/4/05 (Original Publication)
(Updated 7/28/2020)

Table of Contents

Section 1: To the Installer

Installer Safety	1-1
Air-Cooled Machines	1-2
Water Connections	1-2
Electrical Connections	1-2
Beater Rotation	1-3
Refrigerant	1-3

Section 2: To the Operator

Compressor Warranty Disclaimer	2-2
--	-----

Section 3: Safety

Section 4: Parts

Model C709	4-1
Model C709 Single-Spout Door and Beater Assembly	4-2
Model C717	4-3
Model C717 Three-Spout Door and Beater Assembly	4-5
Feed Tube Assembly	4-6
Accessories	4-7
Brushes	4-8

Section 5: User Interface

Symbol Definitions	5-2
Operating Screen Descriptions	5-3
Freezer Locks	5-6
Manager's Menu	5-8
Faults	5-12
System Information	5-15

Table of Contents

Section 6: Operating Procedures

Assembly	6-1
Freezer Door Assembly	6-2
Model C709 Freezer Door Assembly	6-2
Model C717 Freezer Door Assembly	6-4
Feed Tube Assembly	6-6
Sanitizing	6-7
Priming	6-8
Daily Closing Procedures	6-9
Daily Opening Procedures	6-10
Manual Brush-Cleaning	6-11
Draining Product from the Freezing Cylinder	6-11
Rinsing	6-12
Hopper Cleaning.	6-12
Disassembly	6-12
Brush-Cleaning.	6-13

Section 7: Operator's Checklist

During Brush-Cleaning and Sanitizing	7-1
Troubleshooting Bacterial Count	7-1
Regular Maintenance Checks.	7-1
Winter Storage	7-2

Section 8: Troubleshooting Guide

Section 9: Parts Replacement Schedule

Section 10: Limited Warranty on Equipment

Section 11: Limited Warranty on Parts

The following information has been included in the manual as safety and regulatory guidelines. For complete installation instructions, see the installation checklist.

Installer Safety



IMPORTANT! In all areas of the world, machines should be installed in accordance with existing local codes. Please contact your local authorities if you have any questions.

Care should be taken to ensure that all basic safety practices are followed during the installation and servicing activities related to the installation and service of Taylor® machines.

- Only Taylor service personnel should perform installation, maintenance, and repairs on Taylor machines.
- Authorized service personnel should consult OSHA Standard 29CFR1910.147 or the applicable code of the local area for the industry standards on lockout/tagout procedures before beginning any installation or repairs.
- Authorized service personnel must ensure that the proper personal protective equipment (PPE) is available and worn when required during installation and service.
- Authorized service personnel must remove all metal jewelry, rings, and watches before working on electrical equipment.



DANGER! The main power supply(s) to the machine must be disconnected prior to performing any installation, maintenance, or repairs. Failure to follow this instruction may result in personal injury or death from electrical shock or hazardous moving parts, as well as poor performance or damage to the machine.



WARNING! This machine has many sharp edges that can cause severe injuries.

Site Preparation

Review the area where the machine will be installed

before uncrating the machine. Make sure all possible hazards to the user or equipment have been addressed.

For Indoor Use Only: This machine is designed to operate indoors, under normal ambient temperatures of 70°F to 75°F (21°C to 24°C). The freezer has successfully performed in high ambient temperatures of 104°F (40°C) at reduced capacities.



WARNING! This machine must **NOT** be installed in an area where a water jet or hose can be used. **NEVER** use a water jet or hose to rinse or clean the machine. Failure to follow this instruction may result in electrocution.



WARNING! Only install this machine in a location where its use and maintenance is restricted to trained personnel. Failure to comply may result in personal injury.



CAUTION! This machine must be installed on a level surface to avoid the hazard of tipping. Extreme care should be taken in moving this machine for any reason. Two or more persons are required to safely move this machine. Failure to comply may result in personal injury or damage to the machine.

The authorized installer should inspect the machine and promptly report any damage to the local authorized Taylor distributor.

This machine is made using USA sizes of hardware. All metric conversions are approximate and vary in size.

Air-Cooled Machines

Do not obstruct air intake and discharge openings:

- **C709**—A minimum of 6 in. (152 mm) airspace is required on both sides and 0 in. (0 mm) on the rear.
- **C717**—A minimum of 3 in. (76 mm) airspace is required around all sides. Install the deflector provided to prevent recirculation of warm air.

This space allows for adequate airflow across the condenser. Failure to allow adequate clearance can reduce the refrigeration capacity of the freezer and possibly cause permanent damage to the compressor.

Water Connections

(Water-Cooled Machines Only)

An adequate cold water supply must be provided with a hand shutoff valve. On the underside rear of the base pan, two 3/8 in. Iron Pipe Size (IPS) water connections for inlet and outlet have been provided for easy hookup. Permanently connect the machine using 1/2 in. (12.7 mm) inside diameter water lines. (Flexible lines are recommended, if local codes permit.) Depending on local water conditions, it may be advisable to install a water strainer to prevent foreign substances from clogging the automatic water valve. There will be only one water **in** and one water **out** connection. **Do not** install a hand shutoff valve on the water **out** line! Water should always flow in this order: first, through the automatic water valve; second, through the condenser; and third, through the outlet fitting to an **open trap drain**.



IMPORTANT! A backflow prevention device is required on the incoming water connection side. Please see the applicable national, state, and local codes for determining the proper configuration. Water pressure to the unit must not exceed 150 psi (1034 kPa).

Electrical Connections



IMPORTANT! In the United States, this machine is intended to be installed in accordance with the National Electrical Code (NEC), ANSI/NFPA 701987. The purpose of the NEC code is the practical safeguarding of persons and property from hazards arising from the use of electricity. This code contains provisions considered necessary for safety.

In all other areas of the world, the machine should be installed in accordance with the existing local codes. Please contact your local authorities if you have any questions.

Each machine requires one power supply for each data label on the machine. Check the data label(s) on the machine for branch circuit overcurrent protection or fuse, circuit ampacity, and other electrical specifications.

See the wiring diagram provided inside the electrical box for proper power connections.



FOLLOW YOUR LOCAL ELECTRICAL CODES.



WARNING! This machine must be properly grounded. Failure to do so can result in severe personal injury from electrical shock.



IMPORTANT! An equipotential grounding lug is provided with this machine. Some countries require the grounding lug to be properly attached to the rear of the frame by the authorized installer. The installation location is marked by the equipotential bonding symbol (5021 of IEC 60417-1) on both the removable panel and the machine's frame.

**IMPORTANT!**

- *Stationary machines that are not equipped with a power cord and a plug or another device to disconnect the machine from the power source must have an all-pole disconnecting device with a contact gap of at least 0.125 in. (3 mm) in the external installation.*
- *Machines that are permanently connected to fixed wiring and for which leakage currents may exceed 10 mA, particularly when disconnected or not used for long periods, or during initial installation, shall have protective devices to protect against the leakage of current, such as a GFI, installed by authorized personnel to local codes.*
- *Supply cords used with this machine shall be oil-resistant, sheathed flexible cable not lighter than ordinary polychloroprene or other equivalent synthetic elastomer-sheathed cord (code designation 60245 IEC 57) installed with the proper cord anchorage to relieve conductors from strain, including twisting, at the terminals and protect the insulation of the conductors from abrasion.*

If the supply cord is damaged, it must be replaced by a Taylor service technician to prevent a hazard.

Beater Rotation

NOTICE! Beater rotation must be clockwise as viewed looking into the freezing cylinder.

To correct the rotation on a three-phase machine, interchange any two incoming power supply lines at the freezer main terminal block only. To correct rotation on a single-phase machine, exchange leads inside the beater motor. (Follow the diagram printed on the motor.)

Electrical connections are made directly to the terminal block provided in the main control box, located behind the service panel.

It is recommended that beater rotation adjustment be performed by an authorized Taylor service technician.

Refrigerant

CAUTION! This machine contains fluorinated greenhouse gases (F-Gas) to provide refrigeration using a hermetically sealed circuit or within foam insulation. This machine's type of gas, quantity, Global Warming Potential (GWP), and CO₂ tonnes equivalent information is recorded on the machine's data label. The refrigerant used is generally considered nontoxic and nonflammable. However any gas under pressure is potentially hazardous and must be handled with caution.

NEVER fill any refrigerant cylinder completely with liquid. Filling the cylinder to approximately 80% will allow for normal expansion.



CAUTION! Use only approved refrigerant listed on the machine's data label or authorized through a manufacturer's technical bulletin. The use of any other refrigerant may expose users and operators to unexpected safety hazards.



WARNING! Refrigerant liquid sprayed onto the skin may cause serious damage to tissue. Keep eyes and skin protected. If refrigerant burns should occur, flush the area immediately with cold water. If burns are severe, apply ice packs and contact a physician immediately.



NOTICE! Taylor reminds technicians to be aware of and in compliance with local government laws regarding refrigerant recovery, recycling, and reclaiming systems. For information regarding applicable local laws, please contact your local authorized Taylor distributor.



IMPORTANT! *Refrigerants and their associated lubricants may be extremely moisture absorbent. When opening a refrigeration system, the maximum time the system is open must not exceed 15 minutes. Cap all open tubing to prevent humid air or water from being absorbed by the oil.*

Your freezer has been carefully engineered and manufactured to give you dependable operation. When properly operated and cared for, it will produce a consistent, quality product. Like all mechanical products, cleaning and maintenance will be required. A minimum amount of care and attention is necessary if the operating procedures outlined in this manual are followed closely.



IMPORTANT! This manual should be read before operating or performing any maintenance on the machine.

Your Taylor machine will **NOT** compensate for and/or correct any errors made during setup or filling operations. Thus, the initial assembly, setup, and priming procedures are of extreme importance. It is strongly recommended that all personnel responsible for the machine's operation, including assembly and disassembly, go through these procedures together to be properly trained and to make sure that all personnel understand their role in using and maintaining the machine.

If you require technical assistance, please contact your local authorized Taylor distributor.

Note: Your Taylor warranty is valid only if the parts are authorized Taylor parts, purchased from the local authorized Taylor distributor, and only if all required service work is provided by a Taylor service technician. Taylor reserves the right to deny warranty claims on machines or parts if Taylor-unapproved parts or incorrect refrigerant were installed in the machine, system modifications were performed beyond factory recommendations, or it is determined that the failure was caused by abuse, misuse, neglect, or failure to follow all operating instructions. For full details of your Taylor warranty, see the Limited Warranty section in this manual.

Note: Constant research results in steady improvements; therefore, information in this manual is subject to change without notice.

For additional information regarding applicable local laws, contact the municipal facility and/or local distributor.



IMPORTANT! If the crossed-out wheeled bin symbol is affixed to this machine, it signifies that this machine is compliant with the EU directives as well as other similar end-of-life legislation in effect after August 13, 2005. Therefore, it must be collected separately after its use is completed and cannot be disposed as unsorted municipal waste.

The user is responsible for delivering the machine to the appropriate collection facility, as specified by your local code.

For additional information regarding applicable local disposal laws, please contact the municipal waste facility and/or local authorized Taylor distributor.

Compressor Warranty Disclaimer

The refrigeration compressor(s) on this machine are warranted for the term stated in the Limited Warranty section in this manual. However, due to the Montreal Protocol and the U.S. Clean Air Act Amendments of 1990, many new refrigerants are being tested and developed, thus seeking their way into the service industry. Some of these new refrigerants are being advertised as drop-in replacements for numerous applications. It should be noted that in the event of ordinary service to this machine's refrigeration system, **only the refrigerant specified on the affixed data label should be used.** The unauthorized use of alternate refrigerants will void your Taylor compressor warranty. It is the machine owner's responsibility to make this fact known to any technician he/she employs.

It should also be noted that Taylor does not warrant the refrigerant used in its machine. For example, if the refrigerant is lost during the course of ordinary service to this machine, Taylor has no obligation to either supply or provide its replacement either at billable or unbillable terms. Taylor does have the obligation to recommend a suitable replacement if the original refrigerant is banned, obsolete, or no longer available during the 5-year warranty of the compressor.

Taylor will continue to monitor the industry and test new alternates as they are being developed. Should a new alternate prove, through our testing, that it would be accepted as a drop-in replacement, then the above disclaimer would become null and void. To find out the current status of an alternate refrigerant as it relates to your compressor warranty, call the local Taylor distributor or the Taylor factory. Be prepared to provide the model/serial number of the machine in question.

For Units Equipped with Taylor's Remote Monitoring System

FCC / IC ID Label Placement:

- This hardware installation package includes a label that must be placed on the unit immediately after the installation of the IoT hardware device has been completed.
- The label indicates the FCC ID and Industry Canada ID for the wireless communication device. The label must be placed on the outside surface of the machine, in a manner that is visible and unobstructed.
- It is recommended that this label be placed directly adjacent to the product nameplate of this device.

FCC Compliance Statement:

- This equipment has been tested and found to comply with the limits for a Class A digital device, pursuant to part 15 of the FCC Rules.
- These limits are designed to provide reasonable protection against harmful interference when the equipment is operated in a commercial environment.
- This equipment generates, uses, and can radiate radio frequency energy, and if not installed and used in accordance with the instruction manual, may cause harmful interference to radio communications.
- Operation of this equipment in a residential area is likely to cause harmful interference, in which case the user will be required to correct the interference at his own expense.

Industry Canada Statement:

- This device complies with Industry Canada license-exempt RSS standard(s).
- Operation is subject to the following two conditions:
 - a. This device may not cause interference.
 - b. This device must accept any interference, including interference that may cause undesired operation of this device.

We at Taylor Company are concerned about the safety of the operator when he or she comes in contact with the freezer and its parts. Taylor has gone to extreme efforts to design and manufacture built-in safety features to protect both the operator and service technician. As an example, warning labels have been attached to the freezer to further point out safety precautions to the operator.



DANGER! Failure to adhere to the following safety precautions may result in severe personal injury or death. Failure to comply with these warnings may also damage the machine and/or its components. Such damage may require component replacement and service repair expenses.



NOTICE! DO NOT operate this machine without reading this entire manual first. Failure to follow all of these operating instructions may result in damage to the machine, poor performance, health hazards, or personal injury.



IMPORTANT! *This machine is to be used only by trained personnel. It is not intended for use, cleaning, or maintenance by children or people with reduced physical, sensory, or mental capabilities or lack of experience and knowledge, unless given supervision or instruction concerning the use of the machine by a person responsible for their safety. Children should be supervised to ensure that they do not play with the machine.*



WARNING! DO NOT install the machines in an area where a water jet could be used. Failure to follow this instruction may result in serious electrical shock.



WARNING! Avoid injury.

- **DO NOT** operate the machine unless it is properly grounded.
- **DO NOT** operate the machine with fuses larger

than specified on the machine's data label.

- All repairs should be performed by an authorized Taylor service technician.
- The main power supplies to the machine must be disconnected prior to performing installation, repairs, or maintenance.
- **For Cord-Connected Machines:** Only authorized Taylor service technicians or licensed electricians may install a plug or replacement cord on the machine.
- Machines that are permanently connected to fixed wiring and for which leakage currents may exceed 10 mA, particularly when disconnected or not used for long periods, or during initial installation, shall have protective devices to protect against the leakage of current, such as a GFI, installed by the authorized personnel to local codes.
- Stationary machines that are not equipped with a power cord and a plug or another device to disconnect the appliance from the power source must have an all-pole disconnecting device with a contact gap of at least 0.125 in. (3 mm) in the external installation.
- Supply cords used with this machine shall be oil-resistant, sheathed flexible cable not lighter than ordinary polychloroprene or other equivalent synthetic elastomer-sheathed cord (code designation 60245 IEC 57) installed with the proper cord anchorage to relieve conductors from strain, including twisting, at the terminals and protect the insulation of the conductors from abrasion.
- If the supply cord is damaged, it must be replaced by a Taylor service technician to avoid a hazard.
- Secure supply cord ground lead to machine in a location where if the cord is pulled the main power leads become taut before the ground lead can break loose.

Failure to follow these instructions may result in electrocution. Contact your local authorized Taylor distributor for service.



WARNING! Avoid injury.

- **DO NOT** allow untrained personnel to operate this machine.
- **DO NOT** put objects or fingers in the door spout.
- **DO NOT** operate the machine unless all service panels and access doors are fastened with screws.
- **DO NOT** remove the machine door or beater assembly unless the control switches are in the OFF position.

Failure to follow these instructions may result in severe personal injury from hazardous moving parts.

3



WARNING! This machine has many sharp edges that can cause severe injuries.

Examples:

- Scraper blades
- Condenser fins
- Cup/cone dispenser (if applicable)



IMPORTANT! Access to the service area of the machine must be restricted to persons having knowledge and practical experience with the machine, in particular as far as safety and hygiene are concerned.



CAUTION! This machine must be placed on a level surface. Extreme care should be taken when moving for any reason. Two or more persons are required to safely move this machine. Failure to comply may result in personal injury or damage to the machine.



NOTICE! Cleaning and sanitizing schedules are governed by your federal, state, or local regulatory agencies and must be followed accordingly. Please refer to the cleaning section of this manual for the proper procedure to clean this machine.

Do not run the machine without product. Failure to follow this instruction can result in damage to the machine.



CAUTION! This machine is designed to maintain product temperature under 41°F (5°C). Any product being added to this machine must be below 41°F (5°C). Failure to follow this instruction may result in health hazards and poor machine performance.

Do not run the machine without product. Failure to follow this instruction can result in damage to the machine.

Do not obstruct air intake and discharge openings:

- **C709**—A minimum of 6 in. (152 mm) airspace is required on both sides and 0 in. on the rear.
- **C717**—A minimum of 3 in. (76 mm) airspace is required around all sides. Install the deflector provided to prevent recirculation of warm air.

For Indoor Use Only: This machine is designed to operate indoors, under normal ambient temperatures of 70°F to 75°F (21°C to 24°C). The freezer has successfully performed in high ambient temperatures of 104° (40°C) at reduced capacities.

Noise Level: Airborne noise emission does not exceed 78 dB(A) when measured at a distance of 39 in. (1.0 m) from the surface of the machine and at a height of 62 in. (1.6 m) from the floor.

Model C709

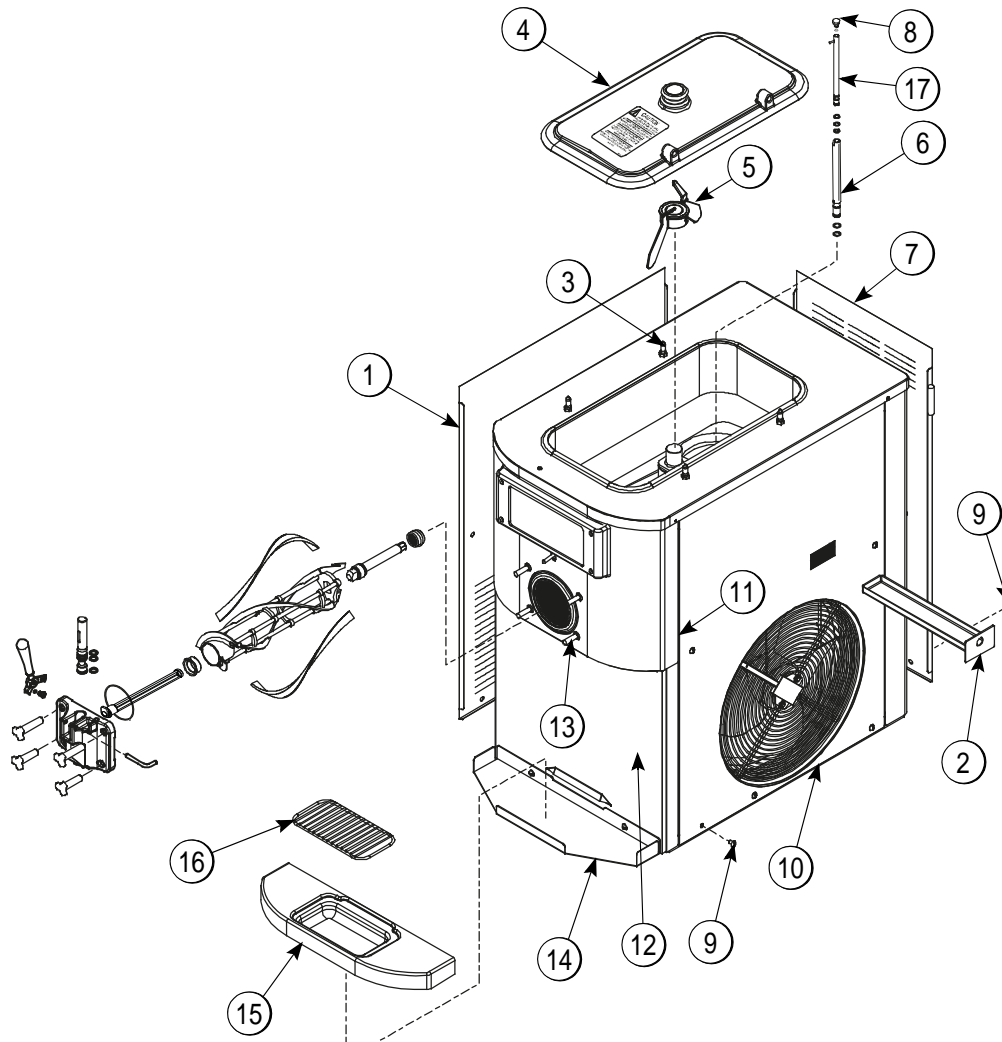

Figure 4-1

Item	Description	Part No.
1	Panel-Side-Left	056963-SP1
2	Pan-Drip 11-5/8 Long	027503
3	Pin-Retaining-Hopper CVR	043934
4	Kit A.-Cover-Hopper	X65368
5	Blade A.-Agitator	X56591
6	Tube A.-Feed-Outer-HT	X34641
7	Panel-Rear	056077-SP1
8	Orifice	022465-100
9	Screw-1/4-20X3/8 RHM-SS	011694

Item	Description	Part No.
10	Panel A-Side-Right	X57871
11	Panel A.-Front-Upper	X59423
12	Panel A.-Front-Lower	X58955
13	Stud-Nose Cone	055987
14	Shelf-Tray-Drip	056076
15	Tray-Drip	056858
16	Shield-Splash	049203
17	Tube A.-Feed-SC-Inner	X32824-2

Model C709 Single-Spout Door and Beater Assembly

4

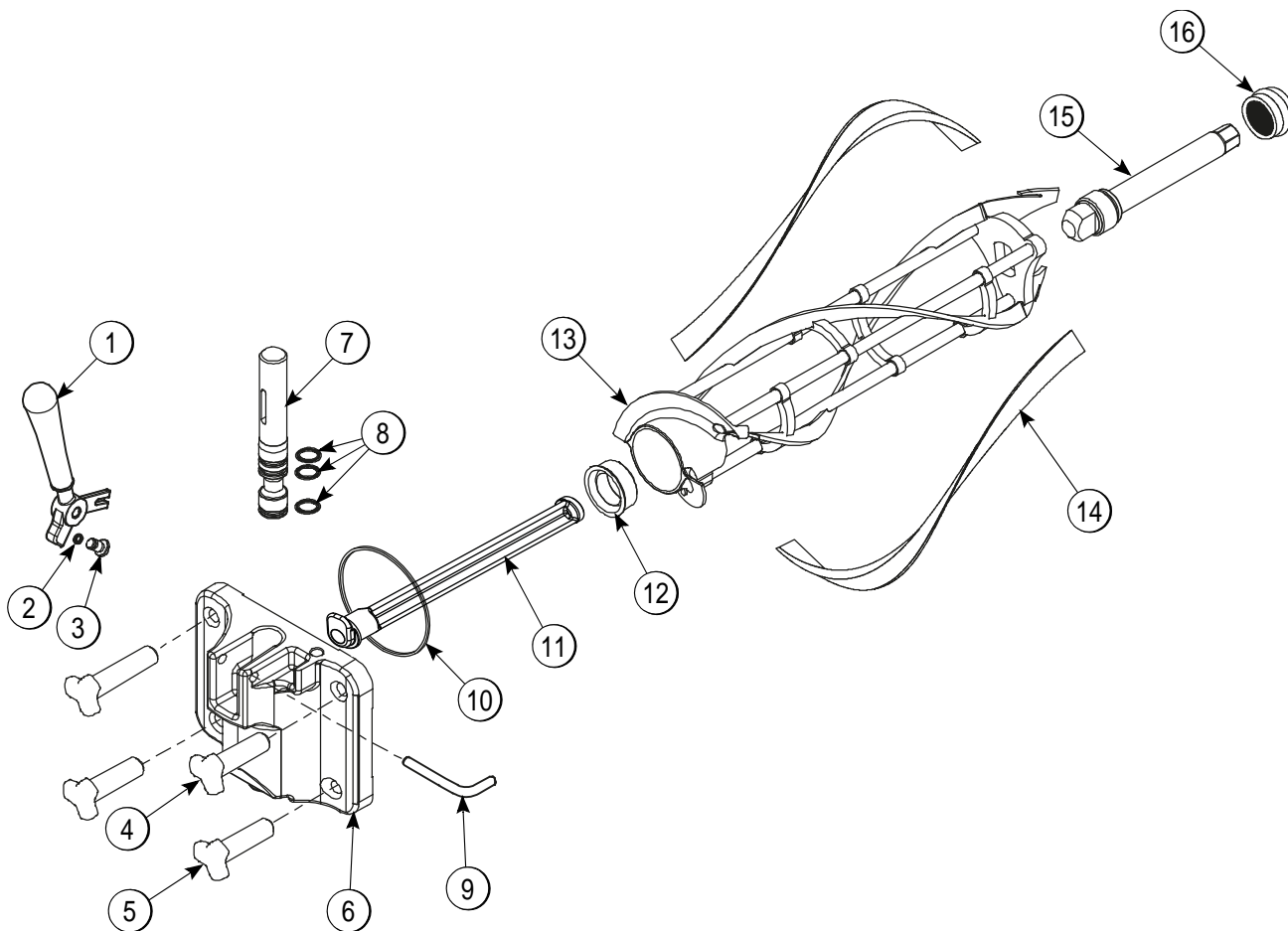
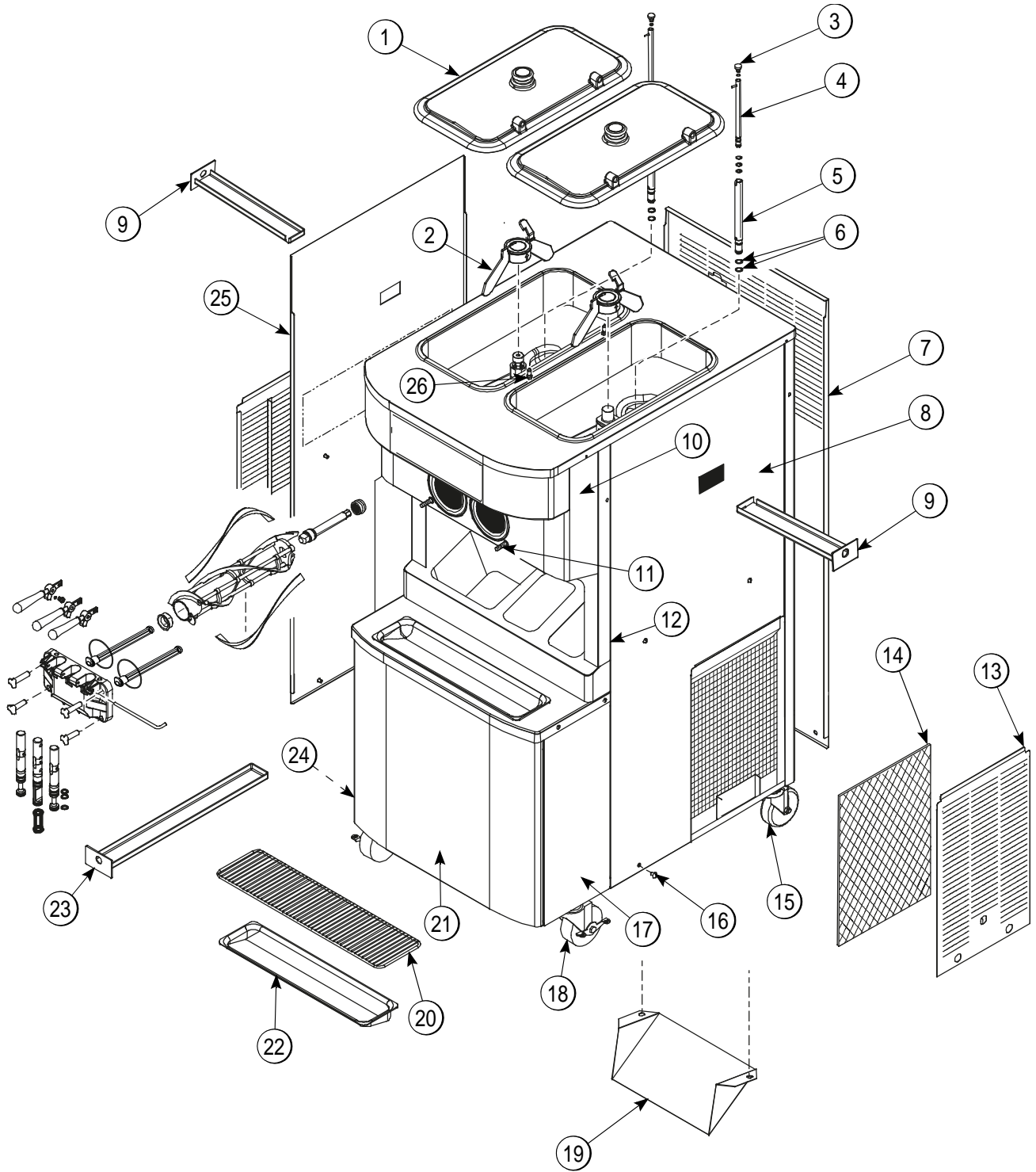

Figure 4-2

Item	Description	Part No.
1	Handle A.-Draw-Welded	X56246
2	O-ring-1/4 OD X .070W 50	015872
3	Screw-Adjustment-5/16-24	056332
4	Nut-Stud Black 3.250"	058765
5	Nut-Stud Black 2.563"	058764
6	Door A.	X87683-1
7	Valve A.-Draw	X55820
8	O-ring-Draw Valve-S.S.	014402

Item	Description	Part No.
9	Pin-Handle-SS	055819
10	Gasket-Door HT 4"-DBL	048926
11	Baffle-Threadless Molded	087708
12	Bearing-Front	088811
13	Beater A.-3.4 qt. Helicore	X31761
14	Blade-Scraper-Plastic	035174
15	Shaft-Beater	056078
16	Seal-Drive Shaft	032560

Model C717



4

Figure 4-3

PARTS

Model C717 Exploded View Parts Identification

Item	Description	Part No.
1	Cover-Hopper	053809-1
2	Blade A.-Agitator	X56591
3	Orifice	022465-100
4	Tube A.-Feed-SC-Inner-3/16	X32824-3
5	Tube A.-Feed-Outer-HT	X34641
6	O-ring-.643 OD X .077 W	018572
7	Panel-Rear	059917
8	Panel-Side-Right	059907
9	Pan-Drip 12.5	059736
10	Panel A.-Front (Middle)	X63879
11	Stud-Nose Cone	055987
12	Panel A.-Front (Upper)	X59836
13	Filter-Air-Poly-FLO	052779-11

Item	Description	Part No.
14	Panel A.-Filter-Louvered	X59928
15	Caster-4" SWV 3/4-10 Stem	044106
16	Screw-1/4-20 X 3/8 RHM-SS	011694
17	Panel-Corner-Front R.	063087
18	Caster-4" SWV 3/4-10 Stem w/ Brake	046437
19	Deflector-Blower	059929
20	Shield-Splash-Wire-19-3/4 L	033813
21	Panel A.-Front Lower	X59854-SER
22	Tray-Drip-19-5/8 L X 4-7/8	033812
23	Pan-Drip 19-1/2 Long	035034
24	Panel-Corner-Front-Left	063088
25	Panel-Side-Left	059906
26	Pin-Retaining-Hopper CVR	043934

4

Model C717 Three-Spout Door and Beater Assembly

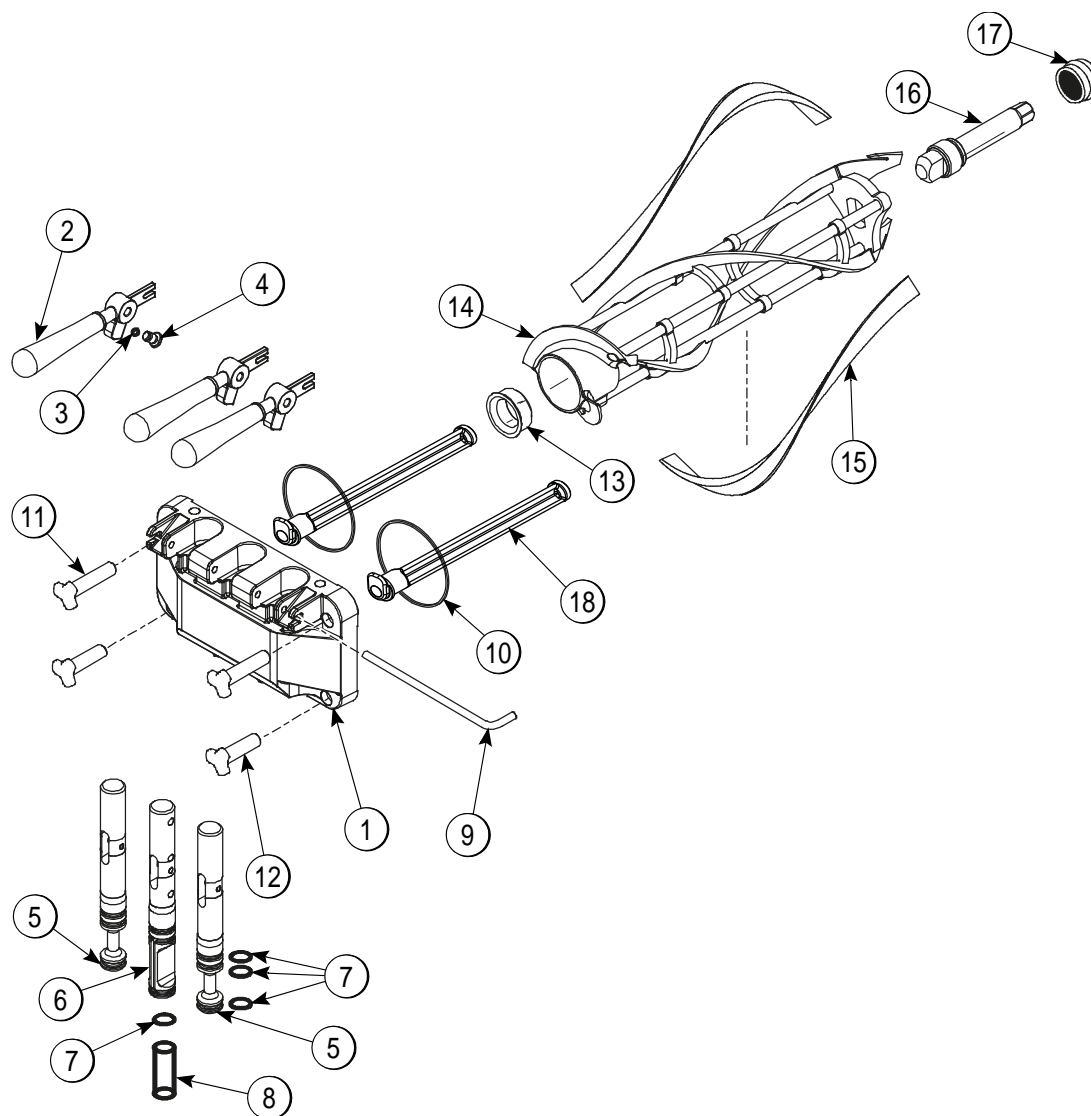

Figure 4-4

Item	Description	Part No.
1	Door A.	X88684-1
2	Handle A.-Draw-Welded	X56421-1
3	O-ring-1/4 OD X .070W 50	015872
4	Screw-Adjustment-5/16-24	056332
5	Valve A.-Draw-L&R	X59888
6	Valve A.-Draw-Center	X59890
7	O-ring-7/8 OD X .103W	014402
8	Seal-Draw Valve	034698
9	Pin-Handle-Twin	059894

Item	Description	Part No.
10	Gasket-Door HT 4"-Double	048926
11	Nut-Stud Black 3.250 Long	058765
12	Nut-Stud Black 2.563 Long	058764
13	Bearing-Front	088811
14	Beater A.-3.4 qt.-Helicore	X31761
15	Blade-Scraper-Plastic	035174
16	Shaft-Beater	032564
17	Seal-Drive Shaft	032560
18	Baffle-Threadless Molded	087708

Feed Tube Assembly

4

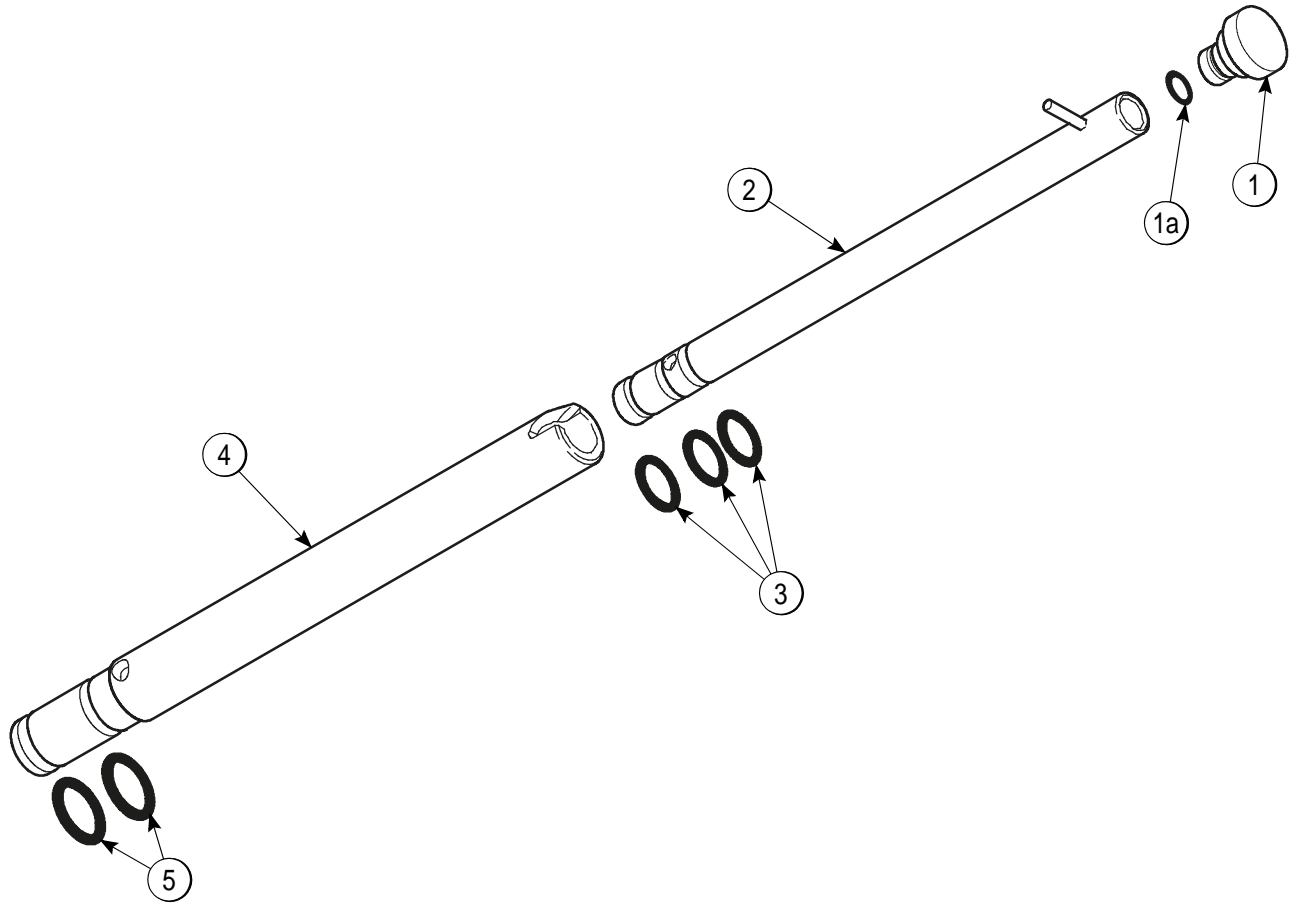

Figure 4-5

Item	Description	Part No.
1	Air Orifice	022465-100
1a	O-ring	016137
2	Tube A.-Feed-SC-Inner (C709)	X32824-2
	Tube A.-Feed-SC-Inner (C717)	X32824-3

Item	Description	Part No.
3	O-ring - 291 ID x .080 W	018550
4	Tube A.-Feed-Outer-HT	X34641
5	O-ring- .643 OD x .077 W	018572

Accessories

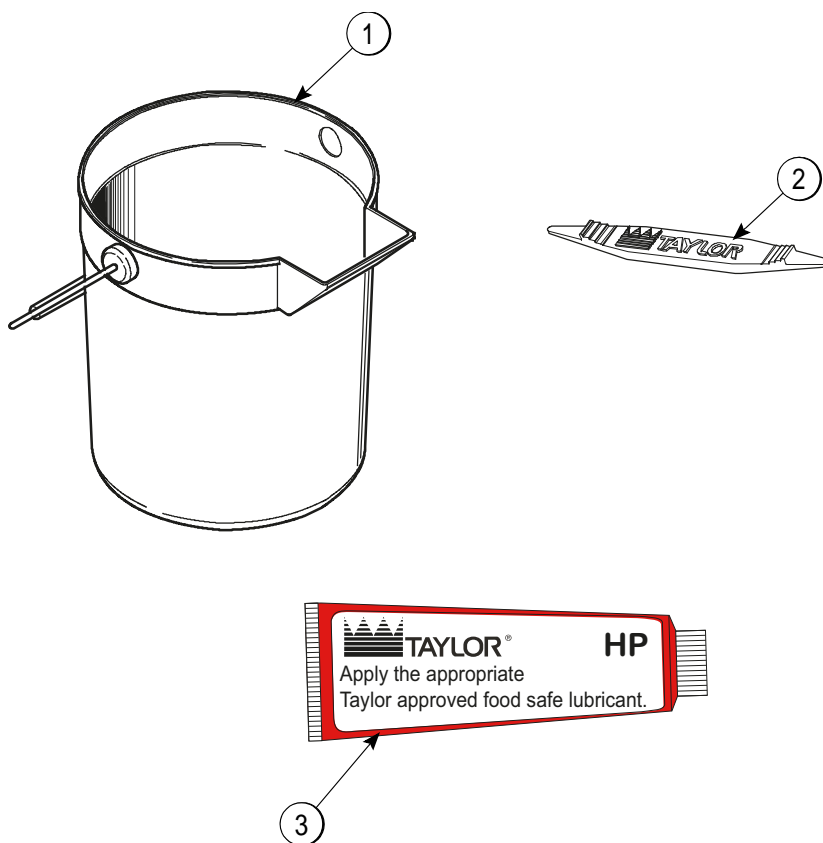

Figure 4-6

Item	Description	Part No.
1	Pail-10 qt.	013163
2	Tool-O-ring Removal	048260-WHT
3	Lubricant-Taylor Hi-Perf	048232

Item	Description	Part No.
*4	Sanitizer-Stera Sheen	055492
*5	Kit A.-Tune-Up (C709)	X49463-92
	Kit A.-Tune-Up (C717)	X49463-79

*Not Shown.

Brushes

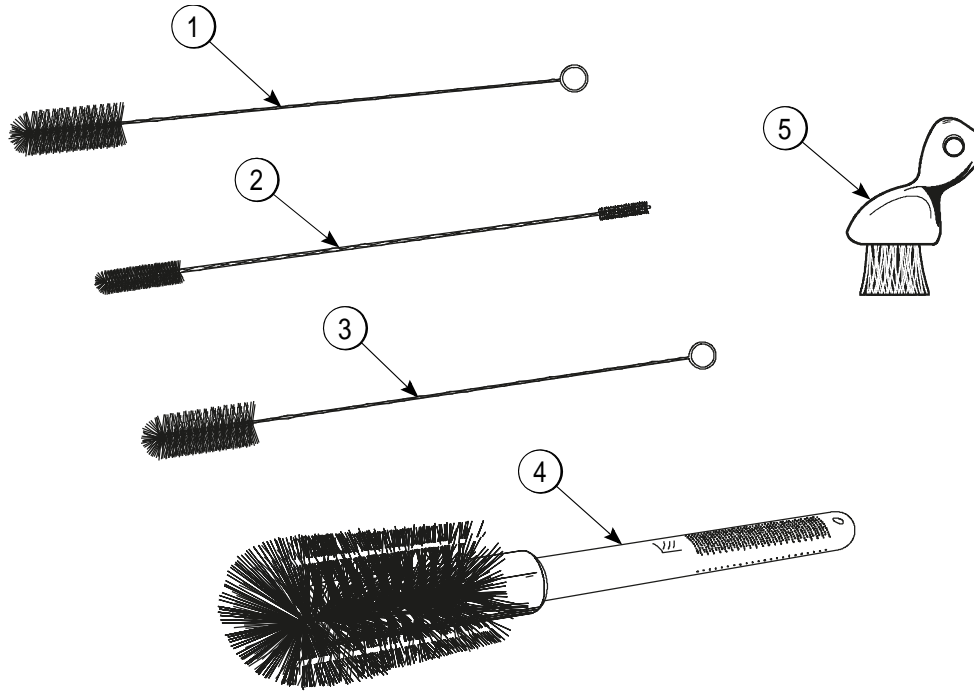

Figure 4-7

Item	Description	Part No.
1	Brush-Rear BRG 1" D X 2" L	013071
2	Brush-Double Ended	013072
3	Brush-Draw Valve 1"OD X 2	013073

Item	Description	Part No.
4	Brush-Mix Pump Body 3" X 7"	023316
5	Brush-End-Door-Spout-SS	039719

User Interface

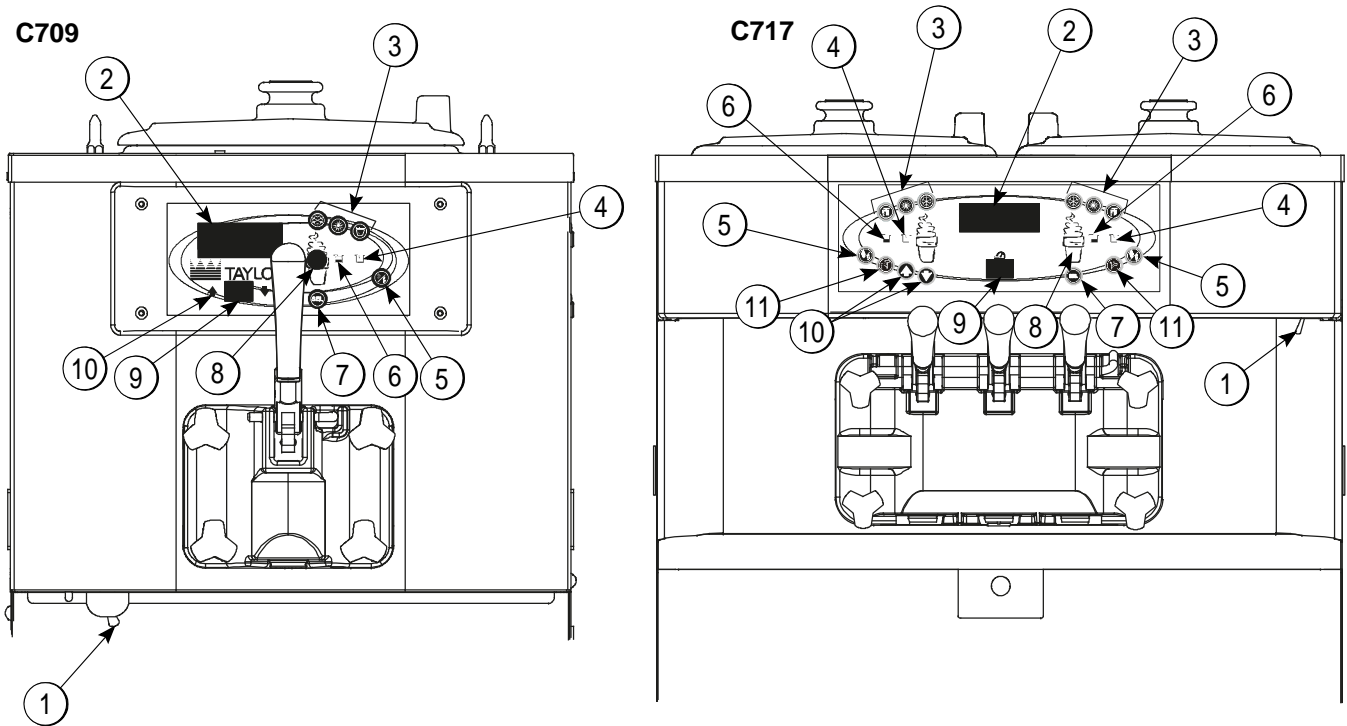

Figure 5-1

5

Item	Description
1	Power Switch
2	Liquid Crystal Display (LCD)
3	Keypads
4	Mix Out Indicator
5	Standby Key
6	Mix Low Indicator
7	Select Key
8	Service Menu Key
9	Brush-Clean Counter
10	Arrow Keys
11	Topping Heater Key

Symbol Definitions

To better communicate in the international arena, symbols have replaced words on many of our operator switches, function, and fault indicators. Your Taylor equipment is designed with these international symbols.

The following chart identifies the symbol definitions.



= Select



= Up Arrow



= Down Arrow



= Auto



= Heat Cycle



= Wash (Model C709)



= Wash (Model C717)



= Mix Low



= Mix Out



= Menu Display



= Standby

Power Switch



When placed in the ON position, the power switch allows control panel operation.

Fluorescent Display

The fluorescent display is located on the front control panel. During normal operation, the display is blank. The display is used to show menu options and notify the operator if a fault is detected. On international models, the display indicates the temperature of the mix in the hopper.

Indicator Lights

Mix Low—When the Mix Low key  is illuminated, the mix hopper has a low supply of mix and should be refilled as soon as possible.

Mix Out—When the Mix Out  key is illuminated, the mix hopper is almost completely exhausted and has an insufficient supply of mix to operate the freezer. At this time, the Auto mode is locked out and the freezer is placed in the Standby mode. To initiate the refrigeration system, add mix to the mix hopper and press the Auto key . The freezer automatically begins operation.

Heat Mode—When the Heat Cycle key  is illuminated, the freezer is in the process of a heat cycle. If enabled, the Heat Cycle key can be pressed to start a heat cycle. If disabled, the Heat Cycle key is inoperable. By default, the Heat Cycle key is enabled.

Brush Clean Counter—When the Brush Clean Counter display has counted down to 1, the machine must be disassembled and brush-cleaned within 24 hours.

Standby Key

The standby feature maintains product temperatures in both the hopper and the freezing cylinder below 40°F (4.4°C). This feature is useful during long “no sale” periods to prevent overbeating and product breakdown.



If enabled, the Standby key  can be pressed to place the machine in the Standby mode. If disabled, the Standby key is inoperable.

Remove the air orifice and turn the inner feed tube so the pin rests on top of the outer feed tube. When Standby is selected, the Standby key  illuminates, indicating the Standby feature has been activated. In the Standby mode, Wash and Auto functions are automatically canceled.

Important! Make sure the level of mix in the hopper is below the mix delivery hole in the feed tube. Failure to follow this instruction may result in lower product quality when normal operation is resumed.

To resume normal operation, press the Auto key . When the machine cycles off, the product in the freezing cylinder will be at serving viscosity. At this time, turn the inner feed tube so the pin fits into the groove of the outer feed tube. Install the air orifice.

Wash Key



The Wash key  (Model C709 or  Model C717) illuminates when pressed. This indicates beater motor operation. Standby or Auto modes must be canceled first to activate the Wash mode.

Auto Key



The Auto key  illuminates when pressed. This indicates that the refrigeration system has been activated. In the Auto mode, Wash or Standby functions are automatically canceled.

Note: An indicating light will illuminate and an audible tone will sound when a mode of operation has been selected. To cancel any function, press the key again. The light and the mode of operation will shut off.

Reset Mechanism

The C709 reset button is in the service panel on the left side of the machine. The C717 reset buttons are in the rear panel of the machine. Reset button(s) protect the beater motor(s) from overloading. Should an overload occur, the reset mechanism will trip. To properly reset the freezer, place the power switch in the OFF position. Press the RESET button firmly. Turn the power switch to the ON position. Press the Wash key / and observe the freezer's performance.

Note: To clear the fault, see page 5-8.

If the beater motor is turning properly, press the Wash key / to cancel the cycle. Press the Auto key  to resume normal operation. If the freezer shuts down again, contact your Taylor service technician.

Adjustable Draw Handle

These machines feature an adjustable draw handle(s) to provide the best portion control, giving a better, consistent quality to your product and controlling costs. The draw handle(s) should be adjusted to provide a flow rate of 5 oz. to 7-1/2 oz. (142 g to 213 g) of product by weight per 10 seconds. To **increase** the flow rate, turn the screw **clockwise**. Turning **counterclockwise** will **decrease** the flow rate.

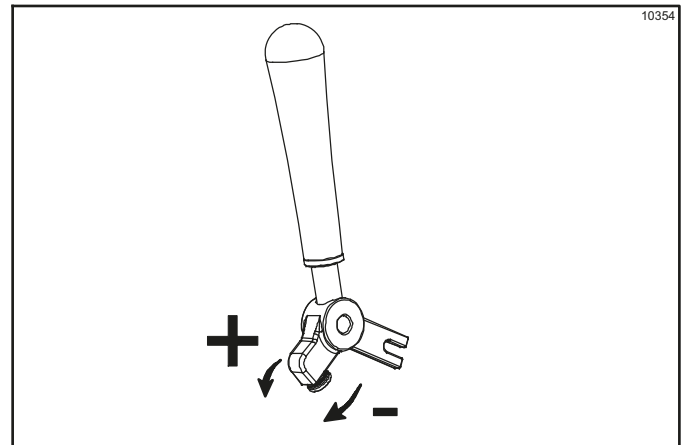

Figure 5-2

Operating Screen Descriptions

The fluorescent display in the center of the control panel is normally blank during the daily operation of the machine. The display is activated when the SEL key or the Manager's Menu is selected. The display screen also alerts the operator of specific faults detected by the control.

Note: The displays illustrated in this section are those seen on Models C709. Model C717 displays may vary slightly.

Power Up Memory (Initializing)

The seven-segment display should display "00" during the initializing sequence.

When the machine is powered, the control system initializes to perform a system check. The screen displays "Initializing." There are four types of data the system checks: Language, System Data, Config Data, and Lockout Data.

Language Initialization

The UVC platform supports multiple languages by keeping specific strings in the battery-backed RAM. After power-up or a CPU reset, the strings are tested to see if they are present and not corrupted. If the strings are present and not corrupted, initialization continues. Otherwise, the operator is prompted to select a language. While language strings are being checked for integrity, the following screen appears.



Note: *If there is a language initialization fault, the machine forces a language selection prior to the initializing sequence. The standard menu LEDs should light as if they were in a menu. If a language has been selected, the machine is powered down, and the machine should not ask for a language unless there is another language initialization fault. English is the factory default setting.*

5

System Data

System data is protected separately from the rest of the data in memory. System data includes variables that change frequently, such as the machine's mode, lockout status, serving counters, and fault codes. While system data is being checked, the following screen appears.



If the system data is corrupted, the machine is set to Off, the serving counters are set to zero, and the faults are cleared. A SYSTEM CRC ERR fault is set and displayed on the VFD. An acknowledgment (SEL key) is required.

Configuration Data

Configuration data is separate from the rest of the data in the memory. Configuration data is information entered through operator and service menus. While configuration data is being checked, the following screen appears.



If configuration data is corrupted, all user and service settings are set to defaults. A CONFIG CRC ERR fault is displayed on the VFD. The system continues to operate in its previous mode, but with default settings.

Lockout Data

Lockout data is protected separately from the rest of the data in the memory. While the lockout data is being checked, the following screen appears.



If lockout data is corrupted, all lockout history data is cleared. A LOCKOUT CRC ERR fault appears.

After the memory integrity has been tested, the Safety Timeout screen appears.

Heat Cycle Data

Heat cycle data is checked separately from the rest of the data in memory. Each individual Heat cycle data record is monitored for corruption individually. At the start of a Heat cycle, the next Heat cycle data record is cleared, and data for the Heat cycle is written to it. The current Heat cycle data appears as the first Heat cycle record in the HEAT CYCLE DATA menu option.

The Heat cycle data records are checked for integrity when the record is accessed, but presently only through the HEAT CYCLE DATA menu option.

Once the system has initialized, the number of days until brush-cleaning is required is indicated on the control panel. The Safety Timeout screen appears with the alarm on for 60 seconds, or until any control key is pressed.

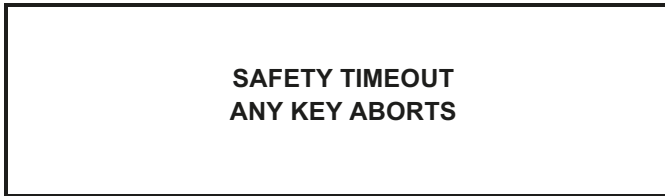

Power Switch Off

After the safety timeout has been completed and the power switch is off, the following screen appears.

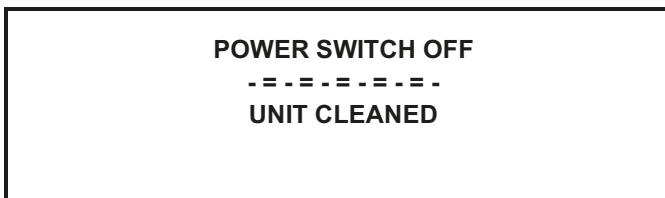

Power Switch On

When the power switch is placed in the ON position, the control panel touch keys become operative. The fluorescent display either is blank or indicates that the machine has been cleaned.

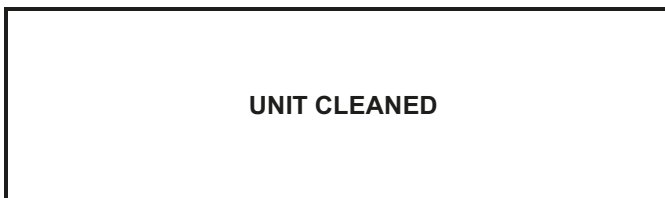

International Models Only

Some international models continuously display the temperature of the mix hopper when the power switch is in the ON position.

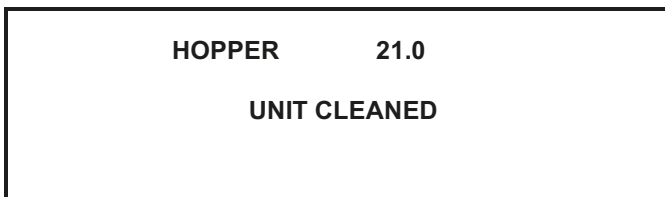

If the control is set for international configuration, the following screen appears when the Heat key is pressed:



Use the Up or Down arrow key to move the cursor to "Yes." Press the SEL key to immediately start a Heat cycle.

Note: The machine must be in Auto or Standby mode and have sufficient mix in the hopper before the machine can successfully enter the Heat mode of operation.

Heat Cycle

The Heat cycle key on the control panel is illuminated throughout the Heat Treatment cycle. Two warning messages appear on the screen. DO NOT DRAW appears when the mix temperature is below 130°F (54.4°C).



When the temperature of the mix is above 130°F (54.4°C), the screen displays the message HOT PRODUCT, indicating that hot product is in the machine.



Important! Do not attempt to draw product or disassemble the machine during the Heat cycle. The product is hot and under extreme pressure.

In the Heat cycle, the mix temperature in the hopper and freezing cylinder must be raised to 151°F (66.1°C) within 90 minutes.

When the heating phase is complete, the freezer goes into the holding phase of the cycle. The holding phase keeps the temperature above 151°F (66.1°C) for a minimum of 35 minutes.

USER INTERFACE

The final phase of the Heat Treatment cycle is the cooling phase. The freezer must cool the mix below 41°F (5°C) within 90 minutes for UVC3 units, or 120 minutes for UVC4 units.

When the entire Heat cycle has been completed, the Heat cycle key is no longer illuminated. The machine enters the Standby mode (Standby key illuminates). The machine can be placed in Auto mode or left in Standby mode.

To comply with health codes, heat treatment system freezers **must** complete a Heat Treatment cycle daily and **must** be disassembled and brush-cleaned according to the frequency specified by your federal, state, or local regulatory agencies. Consult your governing food code to determine the maximum number of days allowed between brush-clean cycles.

Brush-cleaning is the normal disassembly and cleaning procedure found in the Operator's Manual. Failure to follow these guidelines causes the control to lock the freezer out of the Auto mode.

5 If the Heat Treatment cycle fails, the screen displays a failure message and returns the freezer to the Standby mode.

Always comply with local guidelines for the maximum number of days allowed between brush-cleaning.

Freezer Locks

Two types of freezer lock conditions can occur: hard lock or soft lock. A hard lock requires the machine to be disassembled and brush-cleaned. A soft lock can be corrected by either disassembling and brush-cleaning the machine or by starting another Heat Treatment cycle.

Hard Lock

There are two causes of a hard lock failure. The freezer hard locks if either the brush-clean timer has elapsed or a thermistor failure (freezing cylinder or hopper) has occurred during a Heat cycle.

- The following screen appears if a brush-clean cycle time has occurred:

**BRUSH CLEAN TIMEOUT
FREEZER LOCKED
CLEANING REQ'D
> WASH TO BRUSH CLEAN**

Pressing the SEL key displays the following screen:

FREEZER LOCKED

- The following screen appears if there has been a thermistor failure (freezing cylinder or hopper) during the Heat Treatment process:

**SYSTEM FAULT
FREEZER LOCKED
SERVICE REQ'D
> WASH TO BRUSH CLEAN**

Pressing the SEL key indicates which thermistor caused the hard lock.

**HOPPER THERM BAD
FREEZER LOCKED**

If the machine has hard locked and an attempt is made to enter Auto mode, the machine enters the Standby mode and displays the following message.

FREEZER LOCKED

To restore the message that identified the reason for the hard lock, turn the power switch off for 5 seconds and then return the power switch to the ON position. The original message with the reason for the hard lock appears.

The FREEZER LOCKED message remains on the display until the brush-clean requirements are fulfilled. The freezer must be disassembled to activate the 5-minute timer on the display screen. Once the timer counts down to zero, the lockout is cleared.

Soft Lock

If a Heat Treatment cycle has not been initiated within the last 24 hours, a soft lock failure occurs. A soft lock allows the operator to correct the cause of the soft lock. The operator has the option of either starting another Heat cycle or brush-cleaning the machine. When a soft lock occurs, the machine goes into the Standby mode. The following screen appears. The reason for the soft lock is indicated on the third line.

```

NO HEAT CYCLE START
REASON
> HEAT FOR HEAT CYCLE
WASH TO BRUSH CLEAN
    
```

If the reason for the soft lock has been corrected, selecting HEAT CYCLE initiates a Heat cycle immediately. Selecting BRUSH CLEAN hard locks the machine, and brush-cleaning is necessary.

The following table lists the variable messages for soft lock failures that appear on the third line of the screen.

Table 5-1

Message	Description
Power Switch Off	Power switch was in the OFF position.
Mix Out Present	There was a Mix Out condition present.
Auto Or Standby Off	The machine was not in the Auto or Standby mode.
No Heat Cycle Tried	A Heat Treatment cycle was not attempted in the last 24 hours. (AUTO HEAT TIME was advanced, or a power loss was experienced at the time the cycle was to occur.)

If the following screen appears, a soft lock has occurred during the Heat Treatment cycle:

```

HEAT TREAT FAILURE
FREEZER LOCKED
> HEAT FOR HEAT CYCLE
WASH TO BRUSH CLEAN
    
```

A soft lock can also occur anytime during operation when the hopper or freezing cylinder temperature rises above 59°F (15°C), the temperature rises and remains above 45°F (7°C) for more than 1 hour, or the temperature rises and remains above 41°F (5°C) for more than 4 hours.

If a product over temperature condition occurs during operation, the following screen appears.

```

PRODUCT OVER TEMP
> HEAT FOR HEAT CYCLE
WASH TO BRUSH CLEAN
    
```

When this screen appears, automatic freezer operation cannot take place until the freezer is disassembled and brush-cleaned or has completed a Heat Treatment cycle.

Once the freezer is unlocked by starting a Heat Treatment cycle, the Heat Cycle key illuminates and the following message appears on the screen:

```

DO NOT DRAW
    
```

If BRUSH CLEAN is selected to clear the lockout by brush-cleaning the machine, the FREEZER LOCKED message remains on the display until the brush-clean requirements are fulfilled. The freezer must be disassembled to activate the 5-minute timer on the screen. Once the timer counts down to zero, the lockout is cleared.

```

FREEZER LOCKED
    
```

To restore the message that identified the reason for the soft lock, turn the power switch off for 5 seconds, and then return the power switch to the ON position. The original message with the reason for the soft lock appears.

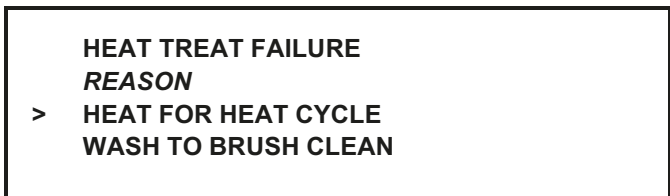

Note: A record of Heat cycle data and lockout history can be found in the Manager's Menu.

Manager's Menu

The Manager's Menu is used to enter the operator function displays. To access the Manager's Menu, press the center of the cone key on the control panel. The arrow keys, the SEL key, and the cone key are lit when the Access Code screen appears.

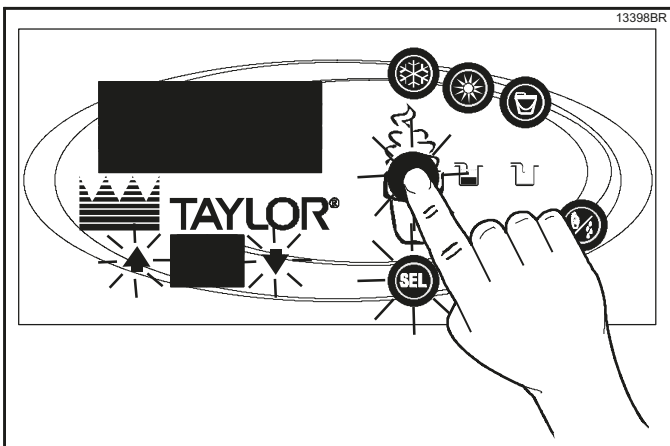

Figure 5-3

In the Manager's Menu, the arrow keys and the SEL key function as menu keys.

- **Up Arrow**—increases the value above the cursor and is used to scroll upward in text displays.
- **Down Arrow**—decreases the value above the cursor and is used to scroll downward in text displays.
- **SEL**—advances the cursor position to the right and is used to select menu options.

There is a 2-minute timeout when you use the Manager's Menu. While in the Manager's Menu, if no activity occurs within a 2-minute period, the display exits to the main menu. One exception to this timeout is for the Current Conditions display.

Note: The machine continues operation in the mode it was in when the Manager's Menu was selected. However, the control keys will not be lit and are nonfunctional when the Manager's Menu appears. The control keys are functional in the Manager's Menu when the Current Conditions screen appears.

Entering Access Code

With the ENTER ACCESS CODE message on the display, use the SEL key to set the first code number in the cursor position. When the correct number is selected, press the SEL key to move the cursor to the next number position.

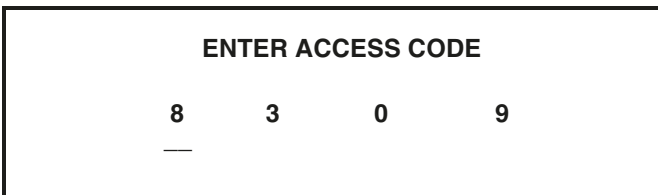

Continue to enter the proper access code numbers (8309) until all four numbers are displayed, then press the SEL key. The Manager's Menu list appears on the screen, provided the correct access code is entered.

If an incorrect number is entered for the access code, the display exits the Manager's Menu when the SEL key is pressed.

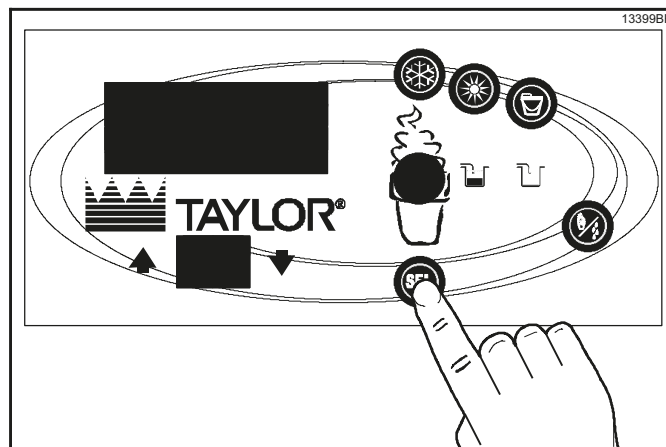
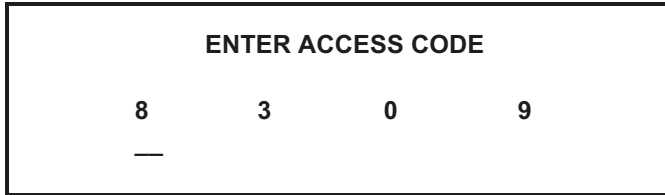

Figure 5-4

Manager's Menu Options

With the ACCESS CODE screen on the display, use the SEL key to set the first code number in the cursor position. When the correct number is selected, press the SEL key to move the cursor to the next number position.



Continue to enter the proper access code numbers (8309) until all four numbers are displayed, then press the SEL key. The Manager's Menu list appears on the screen if correct access code is entered.

If an incorrect number is entered for the access code, the display exits the Manager's Menu when the SEL key is selected.

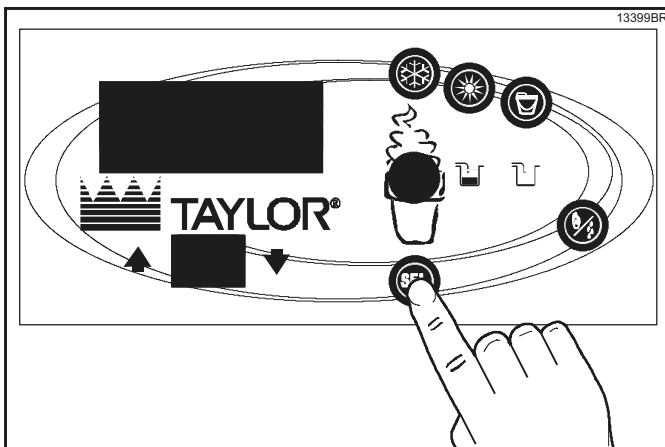



Figure 5-5

Menu Options

Press the arrow keys to move up or down through the menu. Select a menu option by pressing the SEL key. Exit the menu by selecting EXIT FROM MENU, or press the cone key .

The following menu options are listed in the Manager's Menu.

- EXIT FROM MENU
- SERVINGS COUNTER
- SET CLOCK
- AUTO HEAT TIME
- AUTO START TIME
- AUTO STANDBY TIME
- AGITATOR OPERATION

- MIX LEVEL AUDIBLE
- FAULT DESCRIPTION
- FAULT HISTORY
- LOCKOUT HISTORY
- HEAT CYCLE SUMMARY
- HEAT CYCLE DATA
- SYSTEM INFORMATION
- CURRENT CONDITIONS
- ENABLE WIFI

Selecting EXIT FROM MENU exits the Manager's Menu and returns the control panel keys to normal operation.

Use the SERVINGS COUNTER option to check or reset the number of servings dispensed from the machine. The screen automatically resets to zero when the machine is brush-cleaned.

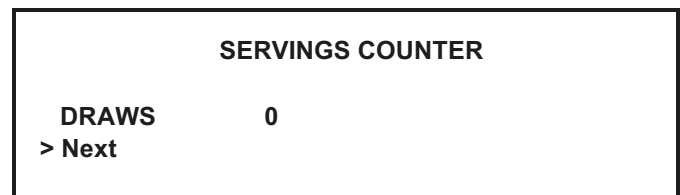

Reset the SERVINGS COUNTER by selecting the SEL key to advance to the next screen. Select the Up arrow to move the arrow (>) to "Yes" and press the SEL key. The servings counter resets to zero and exits back to the Manager's Menu.

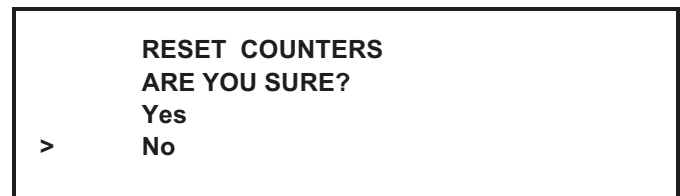

The SET CLOCK option allows you to adjust the control clock date and time. The date and time may only be changed after the freezer has been manually cleaned, but before it has been placed in the Auto or Standby mode. The following message appears if the SET CLOCK option is selected when the machine is not in a brush-clean state.

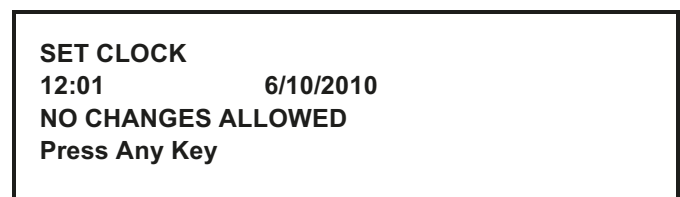

USER INTERFACE

If the machine is in a brush-clean state, pressing the SEL key displays the following screen. Press the Up arrow key to move the arrow from “Exit” to “Change,” and then press the SEL key.

```
SET CLOCK
12:01      6/10/2010
Change
> Exit
```

With the cursor under the hour position, change the time by pressing the Up or Down arrow keys. Move the cursor to the minutes by pressing the SEL key. Once the correct minutes are entered, press the SEL key to advance the cursor to the month.

```
SET CLOCK
12:01      6/10/2010
> Exit
```

Enter the correct month, day, and year. After they have been entered, press the SEL key to advance to the DAYLIGHT SAVING TIME (DST) screen.

```
DAYLIGHT SAVING TIME
ENABLED
> Enable
Disable
```

Pressing the Up or Down arrow keys moves the arrow to “Enable” or “Disable.” Pressing the SEL key next to “Disable” selects that option and returns to the Manager Menu. Pressing the SEL key next to “Enable” selects that option and displays the second screen.

```
MAR Second Sunday
NOV First Sunday
Change
> Exit
```

If the correct Sunday for the time change does not appear, then select “Change.” Pressing the SEL key with the arrow next to “Change” displays the third screen. Press the Up or Down arrow key to move the arrow to the appropriate month for the start of DST.

```
DST START MONTH
> MAR
APR
MAY
```

Pressing the SEL key with the arrow next to the appropriate month displays the following screen:

```
DST START WEEK
> Second Sunday
Third Sunday
Fourth Sunday
```

Press the Up or Down arrow key to move the arrow to the appropriate week for the start of DST. Pressing the SEL key next to the appropriate week displays the following screen. Press the Up or Down arrow key to move the arrow to the appropriate month for the end of DST.

```
DST END MONTH
> NOV
DEC
```

Pressing the SEL key next to the appropriate month displays the following screen. Press the Up or Down arrow key to move the arrow to the appropriate week for the end of DST.

```
DST END WEEK
> First Sunday
Second Sunday
Third Sunday
```

Pressing the SEL key with the arrow by the appropriate week selects that setting and returns to the Manager’s Menu.

The AUTO HEAT TIME screen allows you to set the time of day in which the Heat Treatment cycle starts if the machine is in Auto or Standby mode.

```
AUTO HEAT TIME
00:00
Change
> Exit
```

To set the AUTO HEAT TIME, select the Up arrow key to move the arrow to “Change.” Then press the SEL key. The screen displays the time with the cursor under the hour position.

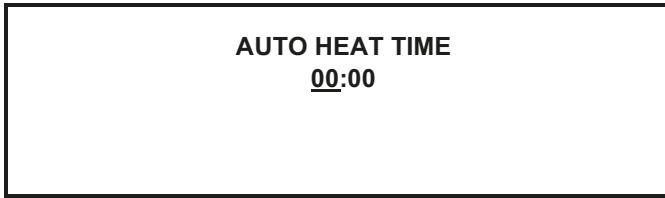

Select the arrow keys to increase or decrease the hour to the desired setting. Then move the cursor to the minutes position by pressing the SEL key. Adjust the setting for minutes, then select the SEL key to save the setting and return to the AUTO HEAT TIME screen. Select the SEL key to exit the screen and return to the Manager’s Menu.

The AUTO START TIME option allows you to set the time of day at which the machine automatically enters the Auto mode from the Standby mode. The machine must be in the Standby mode without a freezer lock condition to auto start at the programmable time. The auto start time can also be disabled and require starting the Auto mode manually.

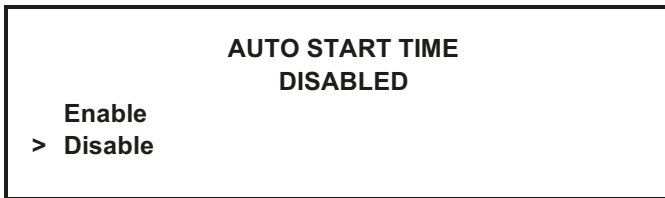

Enable the AUTO START TIME can by selecting the Up arrow key to move the arrow up to “Enable.” Press the SEL key to advance to the next screen.

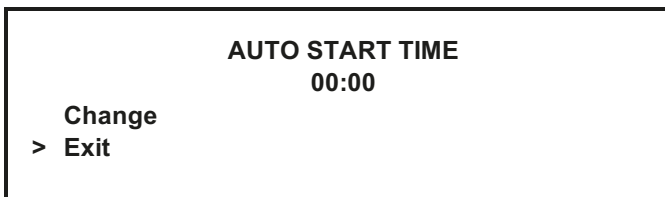

Program the auto start time by selecting the Up arrow key to move the arrow to “Change.” Press the SEL key to advance to the next screen.

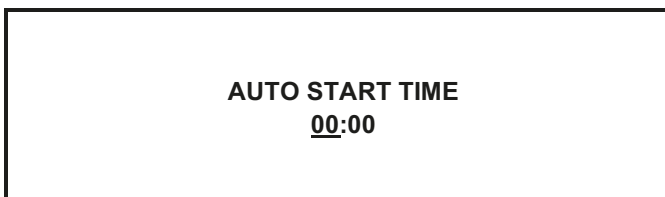

Use the arrow keys to program the auto start time by increasing or decreasing the hour setting above the cursor. Press the SEL key to advance the cursor and program the minutes setting. Select the SEL key to return to the previous screen with the new time setting displayed. Select the SEL key to exit the screen and return to the Manager’s Menu.

The AUTO STANDBY TIME option allows you to set the time of day at which the machine automatically enters the Standby mode from the Auto mode. This allows power saving during slow sales. By default, this feature is disabled.

Enable the AUTO STANDBY TIME by pressing the Up arrow key to move the arrow up to “Enable.” Press the SEL key to advance to the next screen.



Program the auto standby time by pressing the Up arrow key to move the arrow to “Change.” Press the SEL key to advance to the next screen.

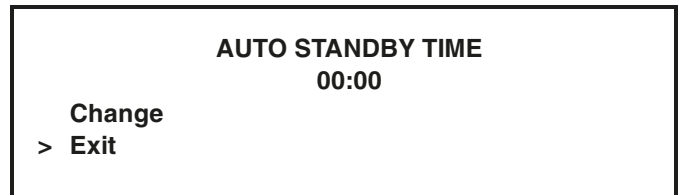

Use the arrow keys to program the auto standby time by increasing or decreasing the hour setting above the cursor. Press the SEL key to advance the cursor and program the minutes setting. Press the SEL key to return to the previous screen with the new time setting displayed. Press the SEL key to exit the screen and return to the Manager’s Menu.

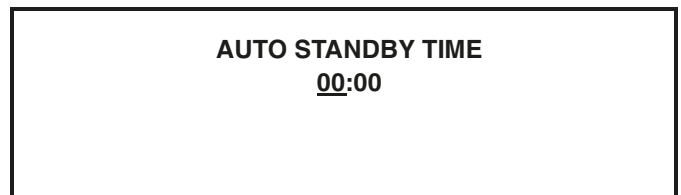

USER INTERFACE

The AGITATOR OPERATION option allows you to select either continuous or intermittent agitator operation.

Agitator operation can be set to operate in the two modes: "Standard operation" or "with Hopper Refrig." For standard operation, the agitator operates during Auto, Standby, and Heat Treatment modes. For Hopper Refrig, the agitator runs only when the hopper is refrigerating and during the heat, hold, and soak phases of a Heat cycle, and the cool phase of a Heat cycle if the hopper is refrigerating. The default is "Standard operation."

AGITATOR OPERATION
> Standard operation
with Hopper Refrig
Exit

Use the arrow keys to move to the desired operation and press the SEL key to accept the selection.

The MIX LEVEL AUDIBLE option, when enabled, alerts the operator with an audible tone when there is Mix Low or Mix Out condition. The following screen appears upon selecting this option.

**MIX LEVEL AUDIBLE
ENABLED**
> Enable
Disable

Disable the audible tone feature by selecting the Down arrow key to move the arrow to "Disable." Select the SEL key to save the new setting and return to the Manager's Menu. The control panel icons for Mix Low and Mix Out illuminate as the mix level drops in the hopper, but the audible tone is disabled.

Faults

The FAULT DESCRIPTION screen indicates a fault with the freezer and where the fault occurred. When no faults are detected, the following screen appears.

FAULT DESCRIPTION
NO FAULT FOUND

Press the SEL key to display the next fault found, or return to the Manager's Menu if no other faults exist. Pressing the SEL key anytime faults appear will clear the faults, if corrected, upon returning to the Manager's Menu screen.

Listed below are the variable messages that appear, along with an explanation for the corrective action.

NO FAULT FOUND—There was no fault found in the freezer. Nothing appears on the screen after this variable message appears.

BEATER OVERLOAD—Place the power switch in the OFF position. Wait 5 minutes for the machine to cool. Press the beater reset button firmly. Place the power switch in the ON position and restart in Auto mode.

COMPRESSOR HPCO—Place the power switch in the OFF position. Wait 5 minutes for the machine to cool. Place the power switch in the ON position and restart in Auto mode.

HOPPER THERMISTOR FAIL*—Place the power switch in the OFF position. Call your authorized service technician.

BARREL THERMISTOR FAIL*—Place the power switch in the OFF position. Call your authorized service technician.

**Note: Three codes have been set up to assist in diagnosing bad thermistor probes. If a probe has shorted, the message SHRT appears for its respective machine location. If the probe is open, the message OPEN appears. If the actual probe environment exceeds 200°F (93°C), the respective screen display location displays OVER, indicating the temperature is out of range.*

COMP ON TOO LONG—The compressor run time exceeded the 11-minute timer. Replace the scraper blades during the next brush-cleaning. If that doesn't resolve the fault, call your authorized service technician.

The FAULT HISTORY screen displays up to 100 faults that have occurred. The most recent fault appears on screen 1. The date, time, and fault description appears on each screen.

FAULT HISTORY 1
00/00/00 00:00
REASON
> Exit

The LOCKOUT HISTORY screen displays a history of the last 100 soft locks, hard locks, brush-clean dates, or aborted Heat cycles. Page numbers are indicated in the upper right-hand corner. Page 1 always contains the most recent failure.

LOCKOUT HISTORY		1
00/00/00	Reason	00:00
> Exit		

The second line of the screen displays the date and time a failure occurs. The third line indicates the reason for a failure, or that a successful brush-cleaning has occurred. Some failures occur with multiple reasons. When this occurs, a page is generated for each reason.

Use the arrow keys to move forward or backward to view each screen. Listed below are the variable messages that may appear:

Faults - Entering a Heat Treatment Cycle

- POWER SWITCH OFF**—The power switch is off.
- AUTO OR STBY OFF**—The control was not in the Auto or Standby mode.
- MIX OUT FAILURE**— A Mix Out condition was present.
- NO HEAT CYCLE TRIED**—The auto heat time was set to attempt a Heat cycle more than 24 hours after the last successful Heat cycle.

Faults in Heat Mode

- HEAT MODE FAILURE**—The maximum allowable heat mode time exceeded 90 minutes.
- COOL MODE FAILURE**—The maximum allowable cool mode time exceeded 90 minutes.
- TOTAL TIME FAILURE**—The maximum allowable total Heat Treatment time exceeded 4 hours.
- BRUSH CLEAN TIMEOUT**—The total days in operation exceeded the brush-clean cycle setting.
- POWER SWITCH OFF**—The power switch was turned off during the Heat cycle.
- POWER FAIL IN H/C**—A power failure occurred during the Heat Treatment cycle.
- MIX LOW FAILURE**—The mix level in the hopper is too low for a successful Heat cycle.

- BEATER OVLD H/C**— The overload tripped for the beater motor.
- BRL THERM FAIL**—The thermistor sensor for the freezing cylinder failed.
- HOPPER THERM FAIL**—The thermistor sensor for the hopper failed.
- HPCO H/C**—The side high-pressure switch opened during the Heat Treatment cycle.

Faults in Auto Mode

- HPR>45F (7C) AFTER 1 HR**—The mix temperature in the hopper was above 45°F (7°C) more than 1 hour.
- BRL>45F (7C) AFTER 1 HR**—The mix temperature in the freezing cylinder was above 45°F (7°C) more than 1 hour.
- HPR>41F (5C) AFTER 4 HR**—The mix temperature in the hopper was above 41°F (5°C) more than 4 hours.
- BRL>41F (5C) AFTER 4 HR**—The mix temperature in the freezing cylinder was above 41°F (5°C) more than 4 hours.
- HPR>41F (5C) AFTER PF**—The mix temperature in the hopper was above 41°F (5°C) more than 4 hours following a power failure.
- BRL>41F (5C) AFTER PF**—The mix temperature in the freezing cylinder was above 41°F (5°C) more than 4 hours following a power failure.
- HPR>59F (15C)**—The mix temperature in the hopper exceeded 59°F (15°C).
- BRL>59F (15C)**—The mix temperature in the freezing cylinder exceeded 59°F (15°C).
- (L/R) TOO COLD**—The mix temperature in the freezing cylinder (barrel) has dropped below 10°F (-12°C).

The HEAT CYCLE SUMMARY screen displays the hours since the last heat cycle, the hours since the product temperature was above 150°F (65.6°C), and the number of heat cycles completed since the last brush-clean date.

HEAT CYCLE SUMMARY	
HRS SINCE HC	0
HRS SINCE 150	0
HRS SINCE BC	0

USER INTERFACE

The HEAT CYCLE DATA screen displays critical times and temperatures for 366 Heat Treatment cycles. Entering this option displays the first screen:

HEAT TREAT CYCLE			
00/00	00:00	00:00	
NO FAULT FOUND			
			1

When in a Heat cycle, a new record is created with the current Heat cycle data. Upon completion of the current Heat cycle, this data is permanently stored as record 1, and all other data records are shifted back one. Record 1 contains the most recently completed Heat cycle. Pressing the Up arrow key cycles the data pages from most recent to oldest. Pressing the Down arrow key cycles from oldest to most recent.

Line 2 displays the month and day the Heat cycle was started, and the start time and end time of the Heat cycle.

Line 3 displays the Heat cycle failure message (if one exists). If no faults were found during the Heat cycle, the screen displays NO FAULT FOUND.

5

Line 4 displays the page number.

Pressing the Up arrow key displays a separate screen for each side of the machine:

H:	42.0	B:	25.0	PS
HEAT	OVER	COOL	PEAK	
0:02	0:00	h	0:00	42.0
0:02	0:00	b	0:00	25.0

Line 1 displays the hopper and barrel temperatures recorded when the Heat cycle ended. The two characters on this line indicate the Heat cycle failure code if a failure occurred.

Line 2 displays the heading for each time and temperature.

Line 3 displays the time spent in the Heat and Cool phases for the hopper and the peak hopper temperature through the entire Heat cycle. It also displays the amount of time that the hopper was greater than the Hold temperature.

Line 4 displays the time spent in the Heat and Cool phases for the barrel, and the peak barrel temperature through the entire Heat cycle. It also displays the amount of time that the barrel temperature was greater than the Hold temperature.

Pressing the SEL or MENU key returns the display to the menu screen.

Table 5-2 lists the variable failure code messages which could appear on line 2.

Table 5-2

Code	Message and Description
HT	Heat Time Too Long Mix temperature did not rise above 151°F (66.1°C) in less than 90 minutes.
CL	Cool Time Too Long Mix temperature in the hopper and freezing cylinder did not fall below 41°F (5°C) in less than 120 minutes.
TT	Total Time Too Long The Heat Treatment cycle must be completed in no more than 4 hours.
MO	Mix Out Condition A Mix Out condition was detected at the start or during the Heat cycle.
ML	Mix Low Condition The Heat Phase or Cool Phase time was exceeded and a Mix Low condition was present.
BO	Beater Overload Condition A beater overload occurred during the Heat cycle.
PF	Power Failure A power failure caused the heat phase, cool phase, or total cycle time to exceed the maximum allowed time. If a power failure occurs, but the Heat Treatment cycle does not fail, an asterisk(*) appears on the third line of the display.
PS	Power Switch OFF The power switch was placed into the OFF position during the Heat cycle.

Code	Message and Description
TH	Thermistor Switch OFF A thermistor probe has failed.
RC	Record Cleared Data has not been written to the page or cleared, due to corrupt data.
OP	Operator Abort Indicates the Heat cycle was aborted in the OPERATOR ABORT option in the Service Menu.
PD	Product Door Not in Place A product door is not in place or is loose.

System Information

System information appears on four separate screens. The first screen contains the control and software version installed in the machine.

SOFTWARE VERSION
C709 CONTROL UVC4
VERSION X.XX
> Next

Press the SEL key to advance to the next system information screen containing the software language version.

Language
V5.01 English
> Next

Press the SEL key to advance to the next screen.

Bootloader
V1.13.000
> Next

Press the SEL key to advance to the system information screen containing the model bill of material and machine serial number. Pressing the SEL key again returns to the Manager's Menu list.

B.O.M. C700000000
S/N M0000000
Othr= 00000
> Next

The Current Conditions screen provides the viscosity readings for the product when the machine is running, as well as hopper and freezing cylinder temperatures for the machine.

VISC 0.0
HOPPER 41.0
BARREL 41.0

The Current Conditions screen is the only Manager's Menu screen that returns the control panel keys to normal operation. The Manager's Menu keys are not lit when this option is selected, but the panel touch keys are fully functional. Exit the Current Conditions screen and return to the Manager's Menu by pressing the SEL key.

ENABLE WIFI

The ENABLE WIFI screen provides the ability to enable/disable the WIFI gateway (if the machine has the optional WIFI equipment).

Press the Up or Down arrow key to move the arrow to the appropriate selection.

Pressing the SEL key with the arrow by the appropriate selection will select that setting and return to the Manager Menu.

Once enabled, the gateway will start broadcasting its access point. This will broadcast until the machine is paired with an Internet connection, or after a 10-minute time-out.

The C709 machine stores mix in a hopper. It has a 3.4 qt. (3.2 L) freezing cylinder with a single-spout door.

The C717 machine stores mix in two hoppers. It has two 3.4 qt. (3.2 L) freezing cylinders with a three-spout door.

We begin our instructions at the point when we enter the store in the morning and find the parts disassembled and laid out to air-dry from the previous night's cleaning.

These opening procedures will show you how to assemble these parts into the freezer, sanitize them, and prime the freezer with fresh mix in preparation to serve your first portion.

If you are disassembling the machine for the first time or need information to get to this starting point in our instructions, see "Disassembly" on page 6-12.

Assembly

Note: When lubricating parts, use an approved food-grade lubricant (example, Taylor Lube).



WARNING! Make sure the power switch is in the OFF position! Failure to follow this instruction may result in severe personal injury to fingers or hands from hazardous moving parts.

Before installing the beater driveshaft, lubricate the groove on the beater driveshaft. Slide the beater driveshaft boot seal over the small end of the beater driveshaft and engage into the groove on the shaft. Heavily lubricate the inside portion of the boot seal and also lubricate the flat end of the boot seal that comes in contact with the rear shell bearing. Apply an even coat of lubricant to the shaft. **Do not** lubricate the hex end.

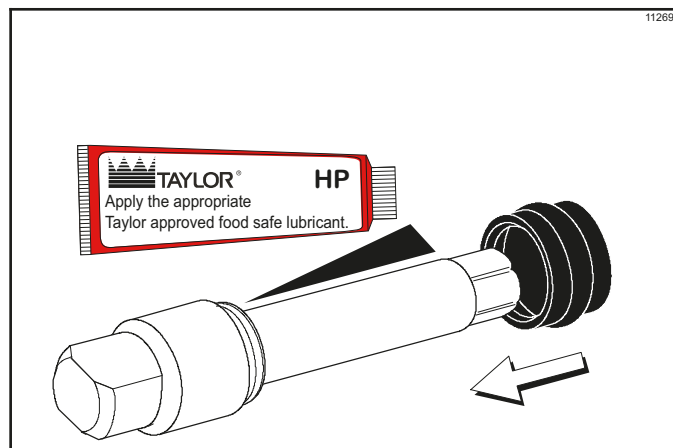

Figure 6-1

Note: To ensure the mix does not leak out of the back of the freezing cylinder, the middle section of the boot seal should be convex, or extend out from the seal. If the middle section of the boot seal is concave, or extending into the middle of the seal, turn the seal inside out.

1. Insert the beater driveshaft through the rear shell bearing in the freezing cylinder and engage the hex end firmly in the drive coupling.

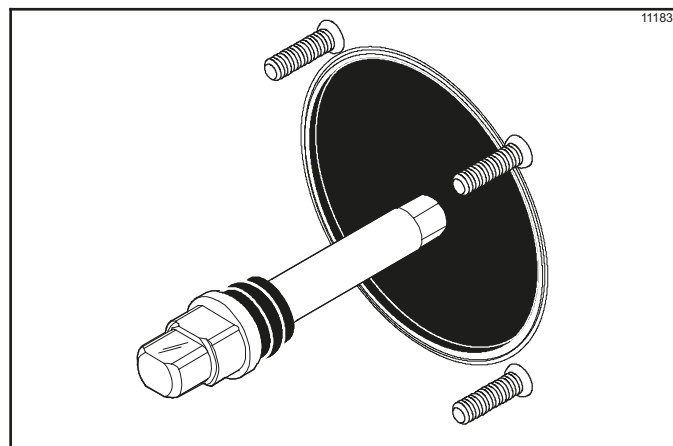

Figure 6-2

OPERATING PROCEDURES

2. Take one of the scraper blades and slip it under the hook at the front of the beater. Wrap the blade around the beater, following the helix and pushing the blade down onto the helix as you wrap. At the back end of the beater, slip the blade under the hook.
3. Repeat step 2 for the second scraper blade.

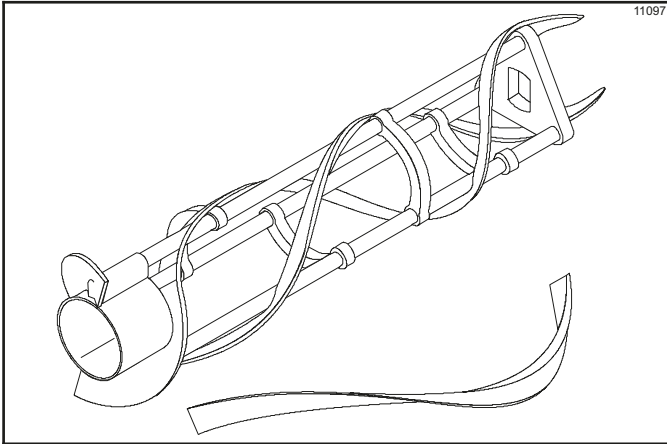

Figure 6-3



WARNING! This machine has many sharp edges that can cause severe injuries.

- 6 4. Holding the beater securely, slide the beater one third of the way into the freezing cylinder. Looking into the freezing cylinder, align the hole at the rear of the beater with the flats on the end of the driveshaft.

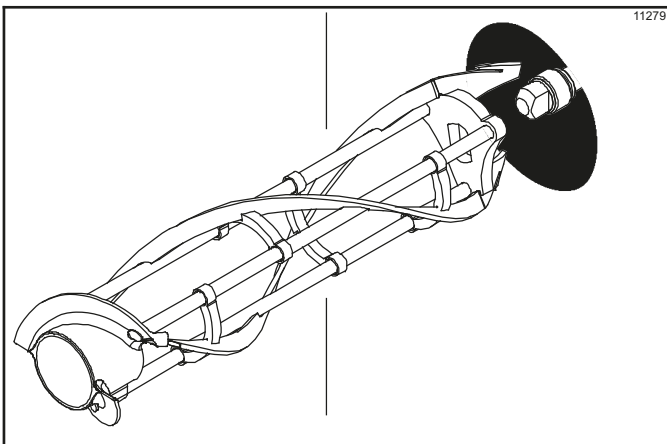

Figure 6-4

5. Slide the beater the remainder of the way into the freezing cylinder and over the end of the driveshaft. The beater should fit snugly, but not so tightly that the beater cannot be turned slightly to engage the driveshaft. If the beater slides in too easily with little

or no resistance, there will not be enough force against the beater to hold the blades in place.

6. Repeat steps 1 through 5 for the other side of Model C717.

Freezer Door Assembly

The assembly of the C709 freezer door is different from the C717 freezer door. Follow the appropriate instructions for your machine.

Model C709 Freezer Door Assembly

1. Install the baffle by raising the round end while engaging the lug into the door pocket. Lower the round end to secure to the door. Place the door gasket into the groove on the back of the freezer door. Slide the front bearing over the baffle rod so the flanged edge is against the door.

Do not lubricate the gasket or bearing.

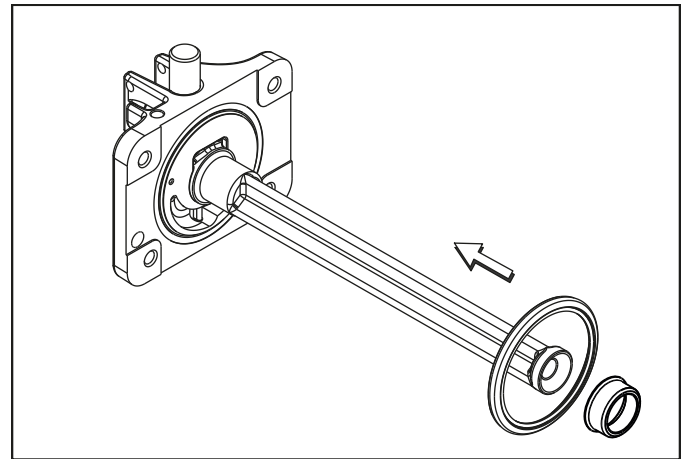

Figure 6-5

2. Slide the three O-rings into the grooves on the draw valve and lubricate.

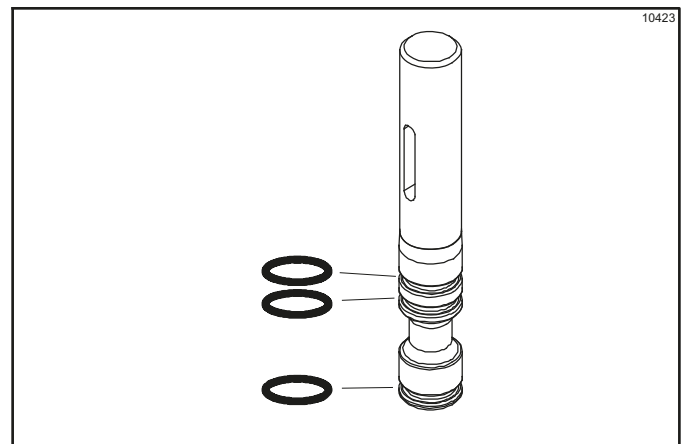

Figure 6-6

- Lightly lubricate the inside of the top of the freezer door valve cavity.

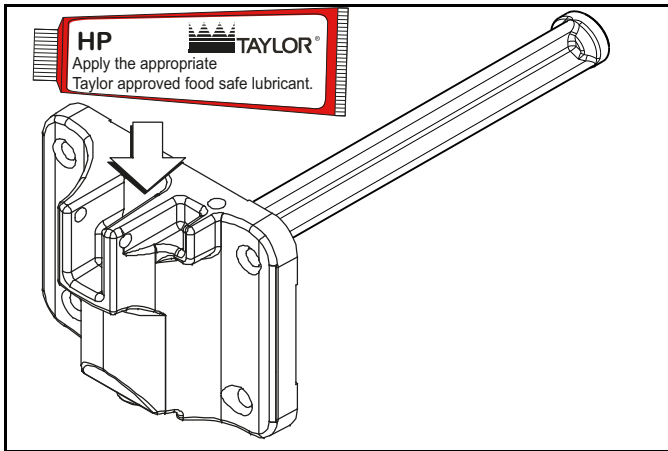

Figure 6-7

- Insert the draw valve from the top, with the draw handle slot facing forward.

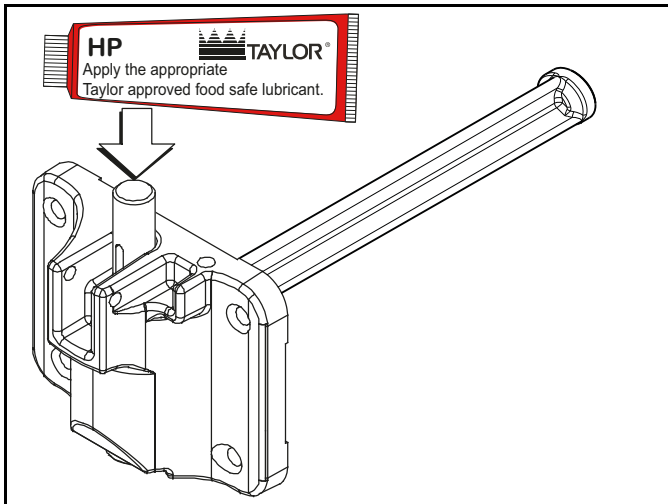

Figure 6-8

- Insert the baffle rod through the beater in the freezing cylinder. With the door seated on the freezer studs, install the handscrews, with the longer handscrews on top. Tighten equally in a crisscross pattern to ensure the door is secure.

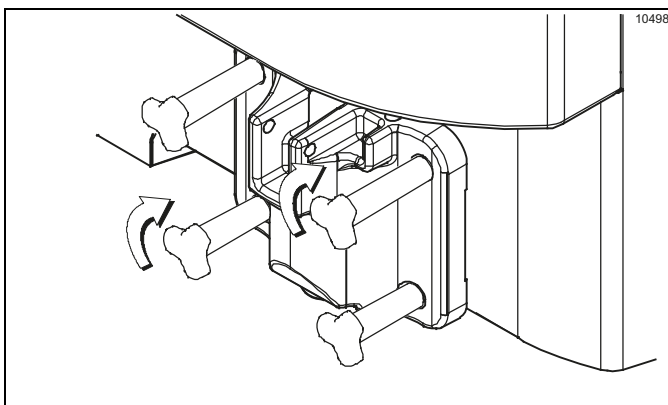

Figure 6-9

- Position the draw handle with the adjustment screw facing down. Slide the fork of the draw handle into the slot of the draw valve. Secure with the pivot pin.

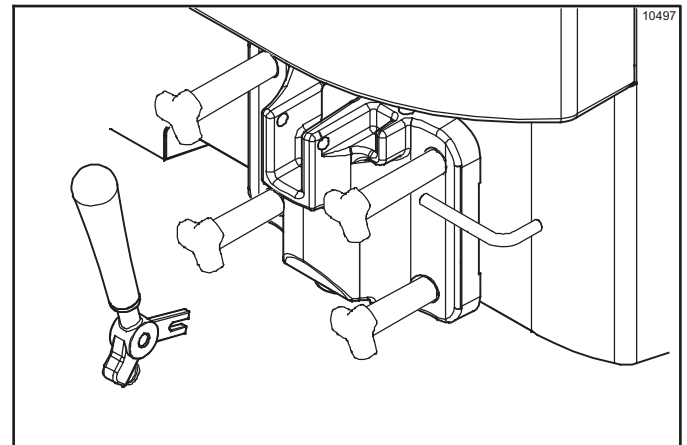

Figure 6-10

Note: The C709 features an adjustable draw handle to provide portion control, giving a better consistent quality to your product and controlling costs.

The draw handle should be adjusted to provide a flow rate of 5 oz. to 7-1/2 oz. (142 g to 213 g) of product by weight per 10 seconds. To **increase** the flow rate, turn the adjustment screw **clockwise**. Turn the adjustment screw **counterclockwise** to **decrease** the flow rate.

- Slide the two drip pans into the holes in the left and right panels.

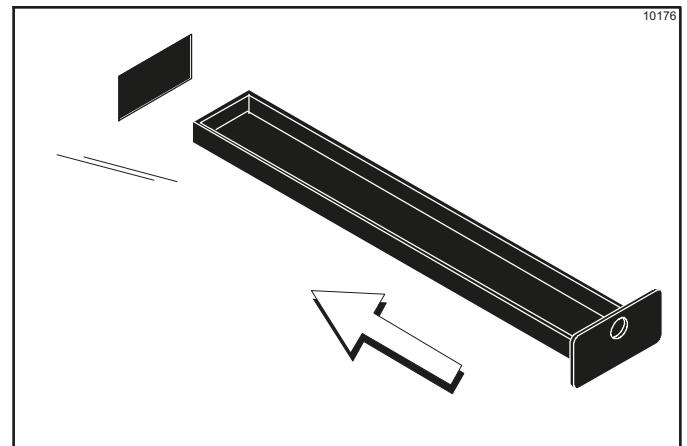

Figure 6-11

OPERATING PROCEDURES

8. Install the front drip tray and splash shield under the door spout.

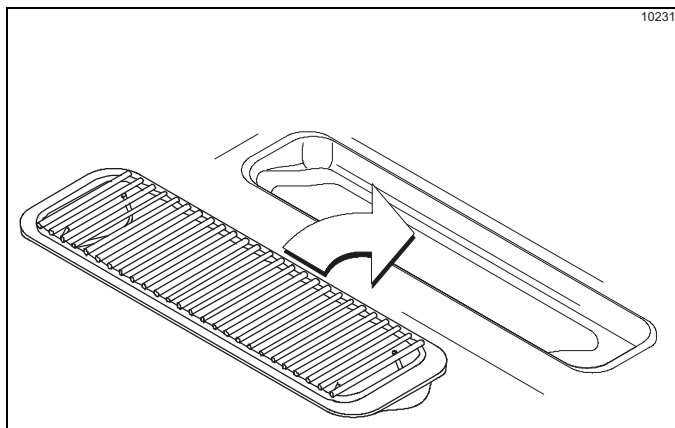

Figure 6-12

Model C717 Freezer Door Assembly

1. Install the baffles by raising the round ends while engaging the lugs into the door pockets. Lower the round ends to secure to the door. Place the door gaskets into the grooves on the back of the freezer door.

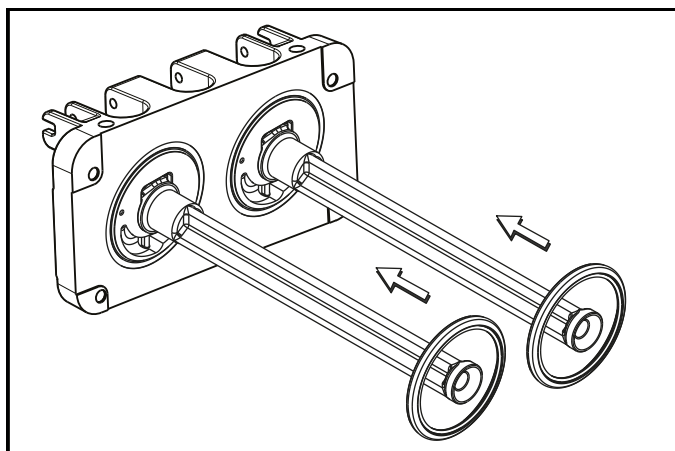

Figure 6-13

2. Slide the front bearings over the baffle rods. The flanged edges should be against the door.

Do not lubricate the gaskets or bearings.

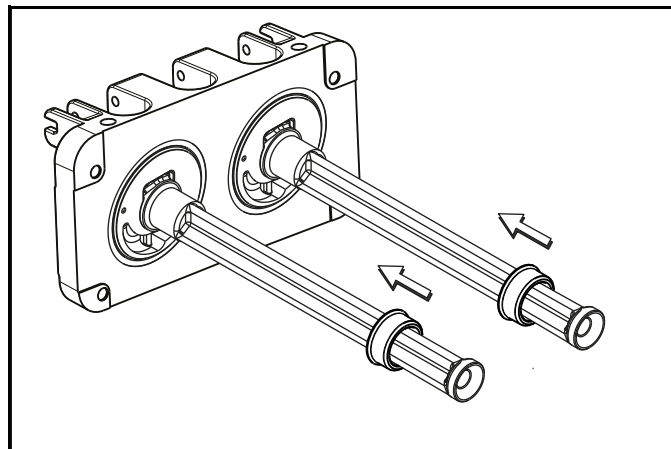

Figure 6-14

3. Insert the baffle rods through the beaters in the freezing cylinders. With the door seated on the freezer studs, install the handscrews with the longer handscrews on top. Tighten equally in a crisscross pattern to ensure the door is secure.

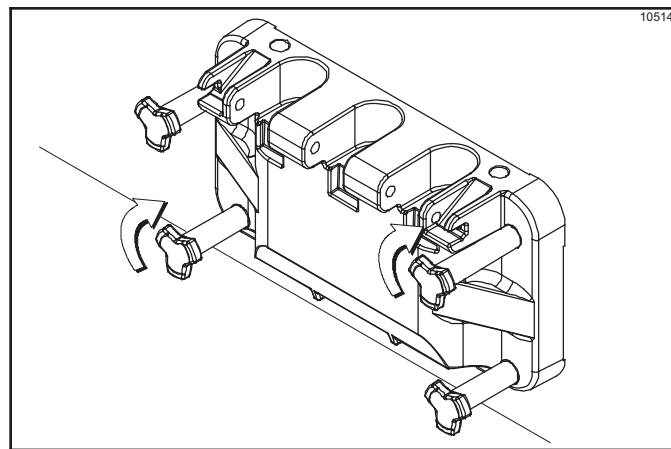

Figure 6-15

- Slide the three O-rings into the grooves of each standard draw valve. Slide the H-ring and O-ring into the grooves of the center draw valve. Lubricate the H-ring and O-rings.

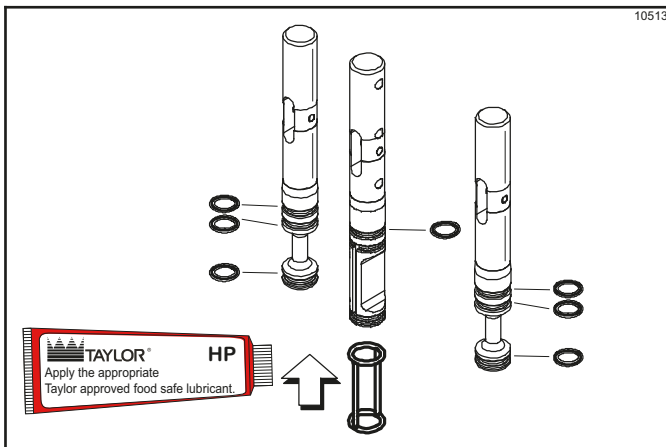

Figure 6-16

- Lubricate the inside of the freezer door spouts (top and bottom).

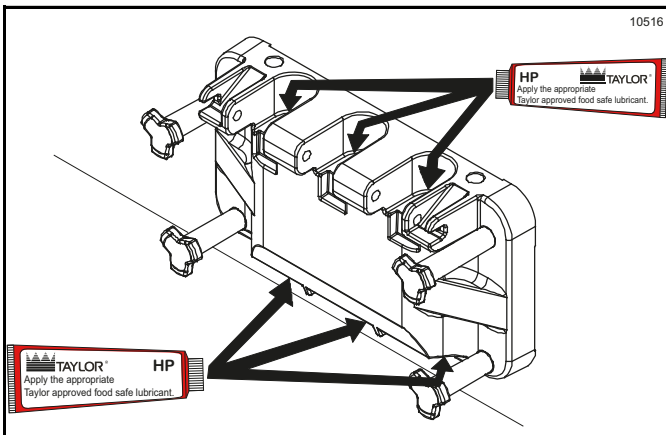

Figure 6-17

- Insert the draw valves from the bottom until the slot in each draw valve comes into view.

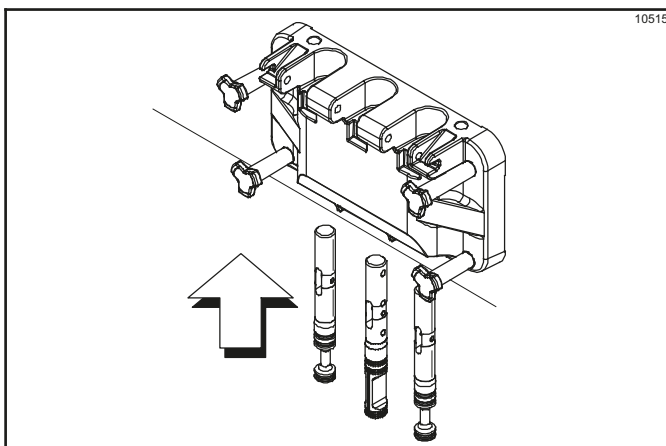

Figure 6-18

- Position each draw handle with the adjustment screw facing down. Slide the fork of each draw handle into the slot of each draw valve, starting from the right.
- Slide the pivot pin through the draw handles as the handles are inserted into the draw valves.

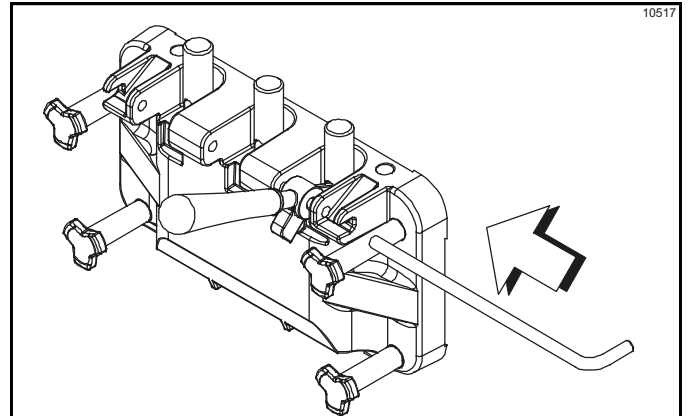

Figure 6-19

Note: This freezer features adjustable draw handles to provide portion control, giving a more consistent quality to your product and controlling costs. The draw handles should be adjusted to provide a flow rate of 5 oz. to 7-1/2 oz. (142 g to 213 g) of product by weight per 10 seconds.

To **increase** the flow rate, turn the adjustment screw **clockwise**. To **decrease** the flow rate, turn the adjustment screw **counterclockwise**.

- Snap the design caps over the bottom of the door spouts.
- Slide the long drip pan into the hole in the front panel. Slide the other two drip pans into the holes in the side panels.

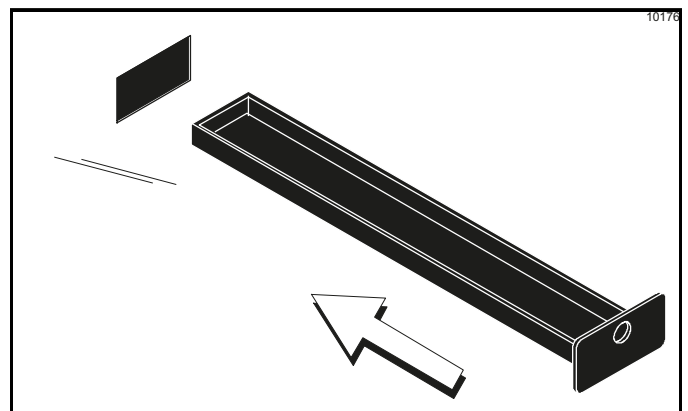

Figure 6-20

- Install the front drip tray and splash shield under the door spouts.

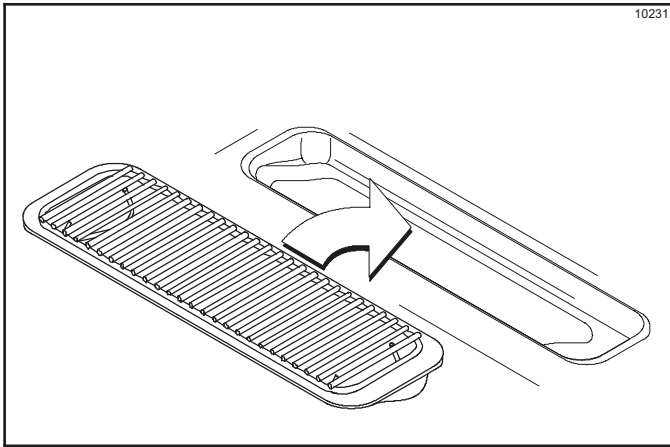

Figure 6-21

Feed Tube Assembly

1. Slide the three O-rings into the grooves of the inner feed tube.

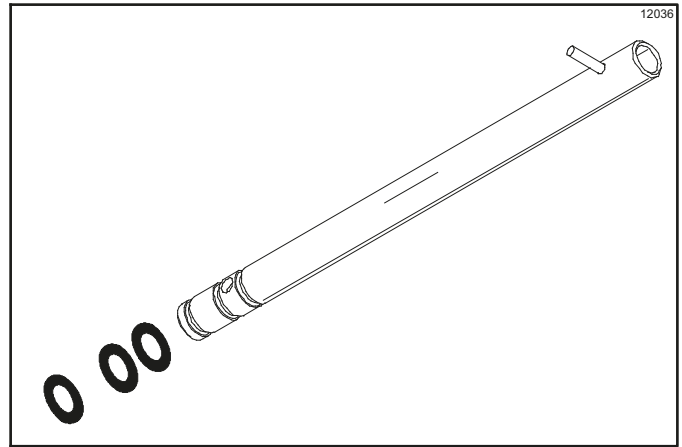

Figure 6-22

2. Slide the two O-rings into the grooves of the outer feed tube.

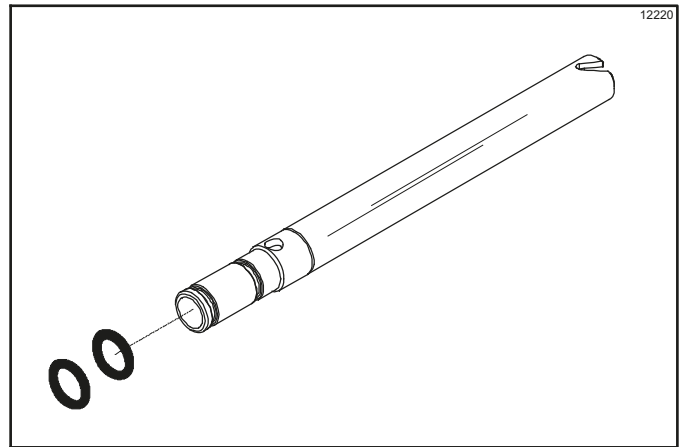

Figure 6-23

3. Slide the small O-ring into the groove of the air orifice.

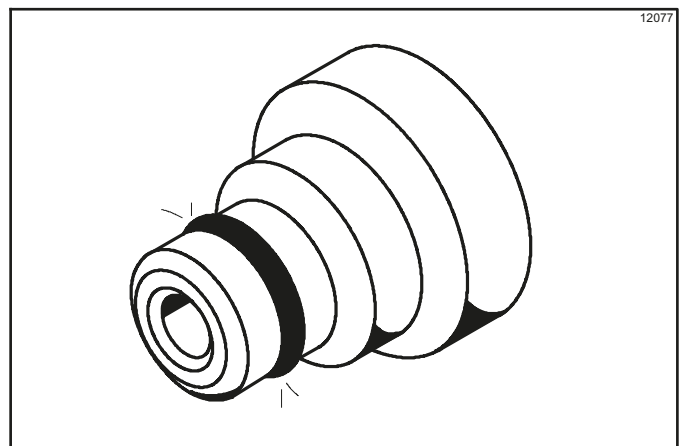

Figure 6-24

Note: Make sure the hole in the air orifice is clean and is not clogged. If the hole in the air orifice becomes clogged, use soap and hot water to clear the hole. **Do not** enlarge the hole in the air orifice.

4. Lay the inner feed tube, the outer feed tube, and the agitator in the bottom of the mix hopper for sanitizing.

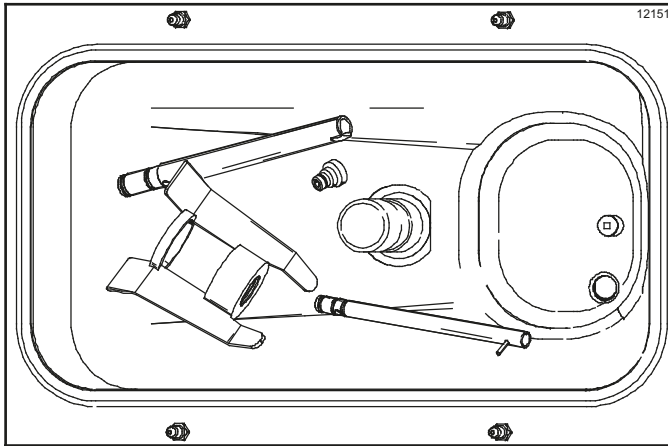

Figure 6-25

5. Repeat steps 1 through 4 for the other side of Model C717.

Sanitizing

1. Prepare an approved 100 PPM sanitizing solution (example, 2-1/2 gal. [9.5 L] of Kay- 5[®] or 2 gal. [7.6 L] of Stera- Sheen[®]).

Note: Use warm water and follow the manufacturer's specifications.

2. Pour the sanitizing solution over all the parts in the bottom of the mix hopper and allow it to flow into the freezing cylinder.

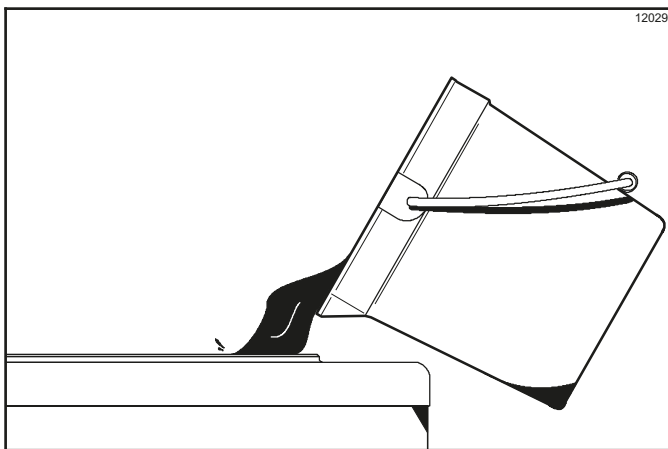



Figure 6-26

Note: Since you sanitized the mix hopper and parts,

make sure your hands are clean and sanitized.

3. While the solution is flowing into the freezing cylinder, brush-clean the mix-level sensing probe on the bottom of the hopper, mix hopper, mix inlet hole, and feed tubes.
4. Place the power switch in the ON position.
5. Press the Wash key  and allow the sanitizing solution in the freezing cylinder to agitate for 5 minutes.
6. With a pail beneath the door spout(s), open and close the draw valve six times. Then open the draw valve and draw off the sanitizing solution.
7. Press the Wash key  and close the draw valve.

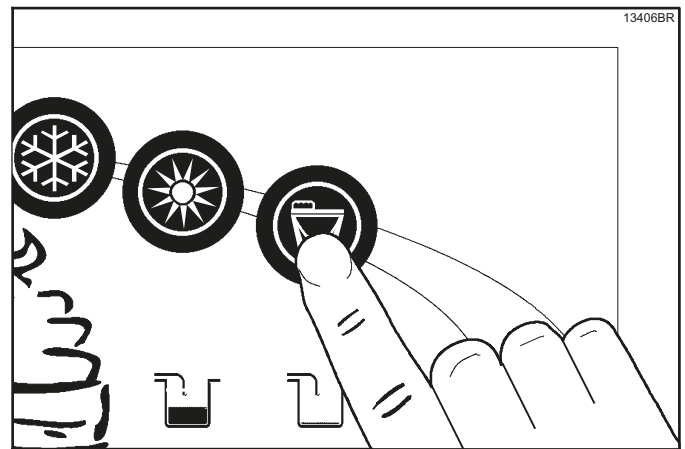

Figure 6-27

Note: Make sure your hands are clean and sanitized.

8. Lubricate the O-rings on the inner and outer feed tubes. **Do not** lubricate the O-ring on the air orifice. Place the inner feed tube inside the outer feed tube.

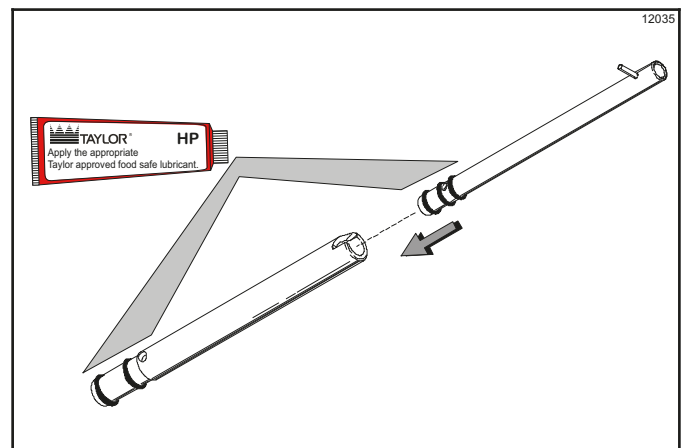

Figure 6-28

OPERATING PROCEDURES

9. Install the air orifice into the hole in the top of the inner feed tube.

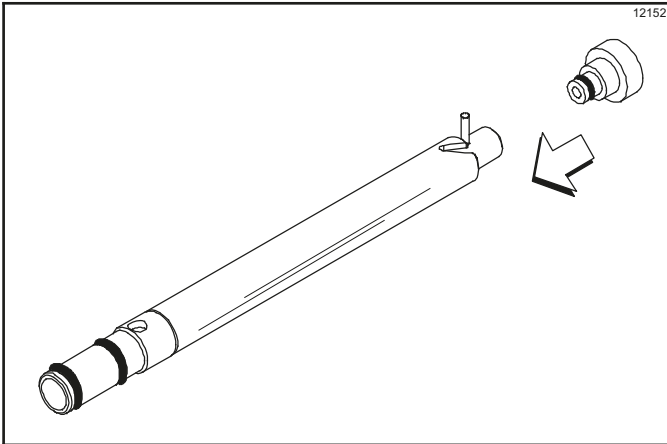

Figure 6-29

Note: Make sure the hole in the air orifice is clean and is not clogged. If the hole in the air orifice should become clogged, use soap and hot water to clear the hole. **Do not** enlarge the hole in the air orifice.

10. Stand the assembled feed tube in the corner of the mix hopper and place the agitator on the agitator housing.

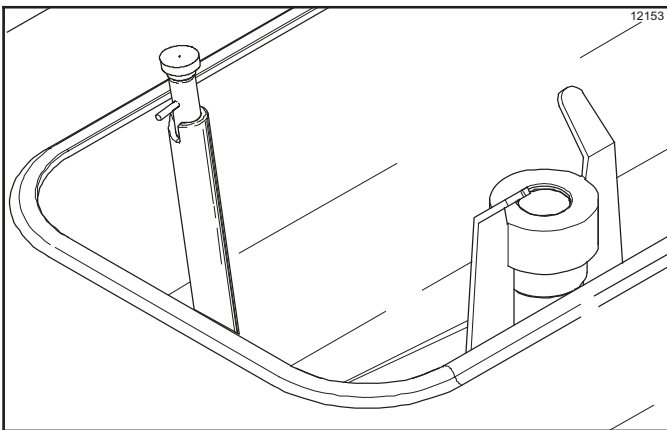

Figure 6-30

Return to the freezer with a small amount of sanitizing solution. Dip the door spout brush into the sanitizing solution and brush-clean the door spout and bottom of the draw valve.

Note: To ensure sanitary conditions are maintained, brush-clean each item for a total of 60 seconds, repeatedly dipping the brush in sanitizing solution.

11. Repeat steps 1 through 10 for the other side of Model C717.

Priming

Note: Use only **fresh** mix when priming the freezer.

1. With a pail beneath the door spout(s), open the draw valve. Pour 2-1/2 gal. (9.5 L) of **fresh** mix into the mix hopper and allow the mix to flow into the freezing cylinder. This process forces out any remaining sanitizing solution. When full-strength mix is flowing from the door spout, close the draw valve.
2. When mix stops bubbling down into the freezing cylinder, install the assembled feed tubes in the mix inlet hole.

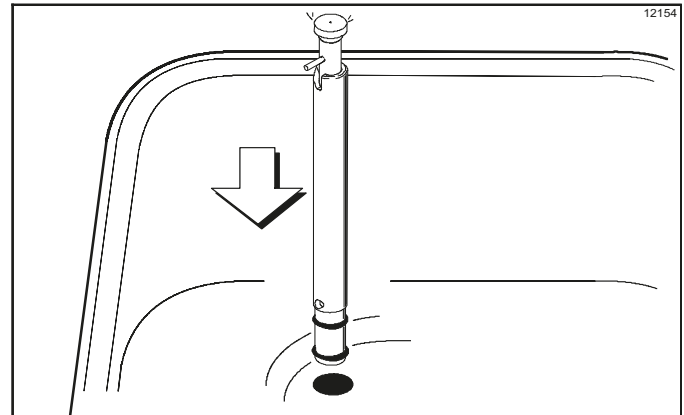

Figure 6-31

The pin on the inner feed tube should be turned and positioned at the bottom of the notch in the outer feed tube. This will align the holes in the feed tubes and allow mix and air to enter the freezing cylinder.

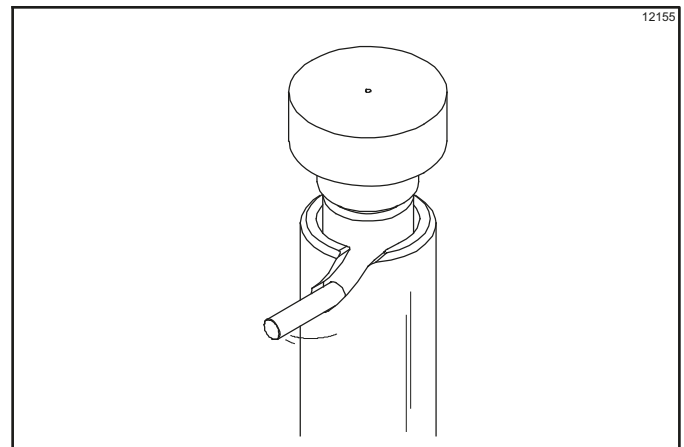

Figure 6-32

3. Select the Auto key ❄️.
4. Fill the hopper with **fresh** mix and place the mix hopper cover in position.
5. Repeat steps 1 through 4 for the other side of Model C717.

Daily Closing Procedures



Perform this procedure once a day.

The function of the Heat Treatment cycle is to destroy bacteria by raising the temperature of the mix in the freezing cylinder and the hopper to a specified temperature for a specified period of time, and then bringing the temperature back down low enough to delay spoilage.

The Heat Treatment cycle starts at the time designated in the Auto Heat Time.

Important! The level of mix in the mix hopper(s) must be up to the fill line on the agitator paddle(s). The Mix Low light must not be on.

Note: If the BRUSH CLEAN COUNTER display has counted down to one day, do not add mix. The machine must be disassembled and brush-cleaned within 24 hours.

The freezer must be in Auto mode (Auto key  illuminated) or in the Standby mode (Standby key  illuminated) before the Heat cycle can be started.

1. Remove the hopper cover(s), drip pan(s), front drip tray, and splash shield. Take them to the sink for cleaning and sanitizing.

Note: Make sure your hands are clean and sanitized.

2. Remove the air orifice(s), the feed tube assembly(ies), and the agitator(s) from the mix hopper(s). Take these parts to the sink for cleaning and sanitizing.

3. Rinse these parts in cool, clean water.

4. Prepare a small amount of an approved 100 PPM cleaning/sanitizing solution (example Kay-5[®] or Stera-Sheen[®]).

Note: Use warm water and follow the manufacturer's specifications.

Brush-clean the parts.

5. Place the front drip tray, splash shield, and air orifice(s) on a clean, dry surface to air-dry overnight or until the Heating cycle is complete.
6. Prepare a small amount of an approved 100 PPM cleaning/sanitizing solution (example Kay-5[®] or Stera-Sheen[®]).

Note: Use warm water and follow the manufacturer's specifications.

Sanitize the drip pans, feed tube assembly(ies), agitator(s), and hopper cover(s).

7. Install the agitator(s) back onto the agitator driveshaft housing(s).

Important! Make sure the agitator(s) are installed and the switch is in the Auto or Standby mode, or the machine will not have a successful Heat cycle.

8. Install the feed tube assembly(ies). Lift and turn the inner feed tube of each assembled feed tube so the pin rests on top of the outer feed tube. This action closes the hole in the assembled feed tubes, preventing mix in the hopper(s) from entering the freezing cylinder(s) during the Heating and Standby process.

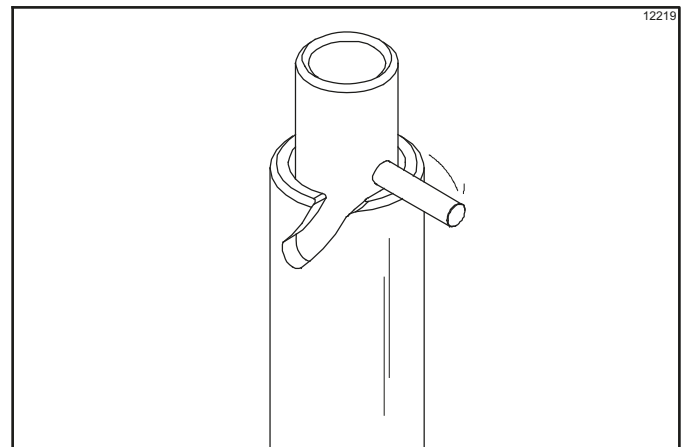

Figure 6-33

9. Replace the hopper cover(s) and install the drip pans.
10. Return to the freezer with a small amount of cleaning solution. Dip the door spout brush into the cleaning solution and brush-clean the door spout(s) and the bottom of the draw valve(s).

Note: To ensure sanitary conditions are maintained, brush each item for 60 seconds, repeatedly dipping the brush in cleaning solution.

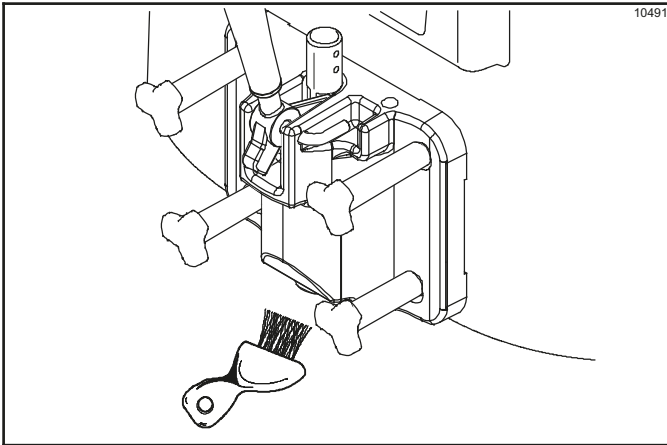



Figure 6-34

11. Using a clean, sanitized towel, wipe down the freezer door, front panel, the area around the bottom of the freezer door, and any other areas with a buildup of either moisture or food substance.

The Heat cycle starts when the clock on the machine reaches the Auto Heat Time set in the Manager's Menu.

There are three phases of the Heat cycle: heating, holding, and cooling. Each phase has a time limit. If any one of the three phases fails to reach the proper temperatures within the time limit, the cycle automatically ends and returns to the Standby mode.

A failure message appears on the fluorescent display to inform the operator that the machine did not successfully complete the Heat Treatment cycle. The product may not be safe to serve. The freezer is locked out (soft lock) of the Auto mode. The operator is given the option of selecting the Heat key , which begins a new Heat cycle, or pressing the Wash key , which places the freezer in the Off mode to allow a brush-clean of the machine.

Note: Once the Heat cycle has started, the process cannot be interrupted. The Heat cycle takes a maximum of 4 hours to complete with full hoppers.

Important! Do not attempt to draw product or disassemble the machine during the Heat cycle. The product is hot and under extreme pressure.

When the Heating cycle is complete, the machine returns to Standby mode. The Standby key(s)  illuminate.

Daily Opening Procedures

Before performing the opening procedures, check the display panel for error messages. Normally, the display is blank unless an operational fault has occurred. If a fault is detected, investigate the cause and follow the instructions on the display before proceeding with the opening procedures. See "Faults" on page 5-12.

Setting Up

Note: Make sure your hands are clean and sanitized.

1. Prepare a small amount of an approved 100 PPM sanitizing solution (example Kay-5[®] or Stera-Sheen[®]).
- Note:** Use warm water and follow the manufacturer's specifications.
2. Sanitize the air orifice(s), front drip tray, and splash shield in this solution.
 3. Return to the freezer with a small amount of sanitizing solution. Dip the door spout brush into the sanitizing solution and brush clean the door spout(s) and bottom of the draw valve(s).

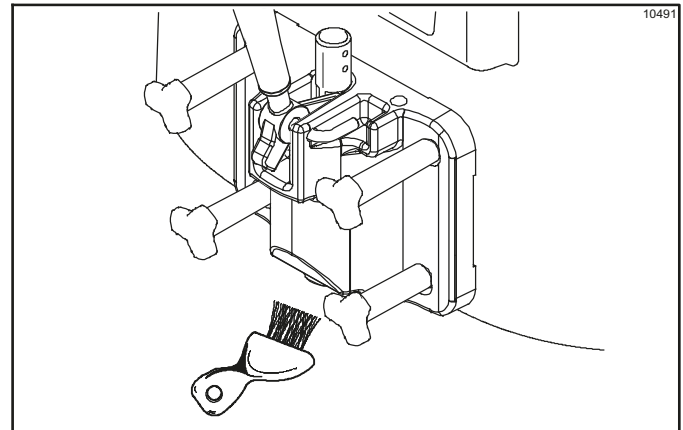

Figure 6-35

Note: To ensure sanitary conditions are maintained, brush-clean each item for 60 seconds, repeatedly dipping the brush in sanitizing solution.

4. Using a clean, sanitized towel, wipe down the freezer door, front panel, the area around the bottom of the freezer door, and any other areas with a buildup of either moisture or food substance. Install the front drip tray and the splash shield.

- To resume normal operation, press the Auto key. When the machine cycles off, the product in the freezing cylinder will be at serving viscosity.

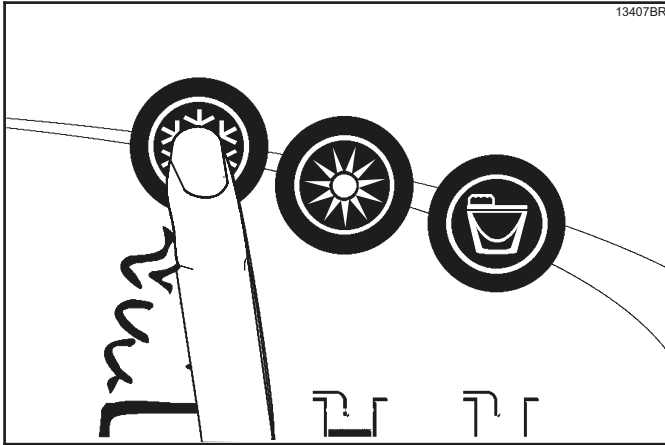

Figure 6-36

- Lift the hopper cover(s). Turn the inner feed tube of each assembled feed tube so the pin rests at the bottom of the notch of the outer feed tube. Install the air orifice(s).

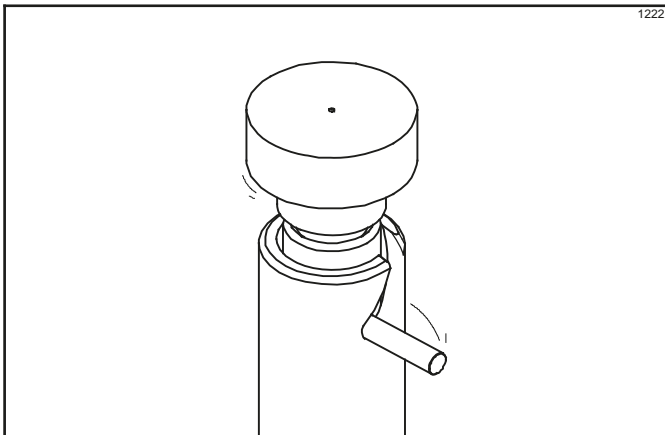

Figure 6-37

The control has a feature in the Manager's Menu to enable or disable the Auto Start feature. When Auto Start is enabled, the machine automatically exits the Standby mode and starts the machine in the Auto mode at a designated time each day.

Note: This procedure should be performed 15 minutes before serving product.

Manual Brush-Cleaning

These procedures must be completed according to the frequency specified by your federal, state, or local regulatory agencies. Consult your governing food code to determine the maximum number of days allowed between brush-clean cycles.





ALWAYS FOLLOW LOCAL HEALTH CODES.

To disassemble and brush-clean the machine, the following items are needed:

- Two cleaning and sanitizing pails
- Sanitizer/cleaner
- Cleaning brushes (provided with freezer)
- Single-service towels

Draining Product from the Freezing Cylinder

- Press the Auto key , canceling the compressor and beater motor operation.
- Remove the hopper cover, agitator paddle, and assembled feed tube. Take these parts to the sink for cleaning.
- With a pail beneath the door spout(s), press the Wash key  and open the draw valve.

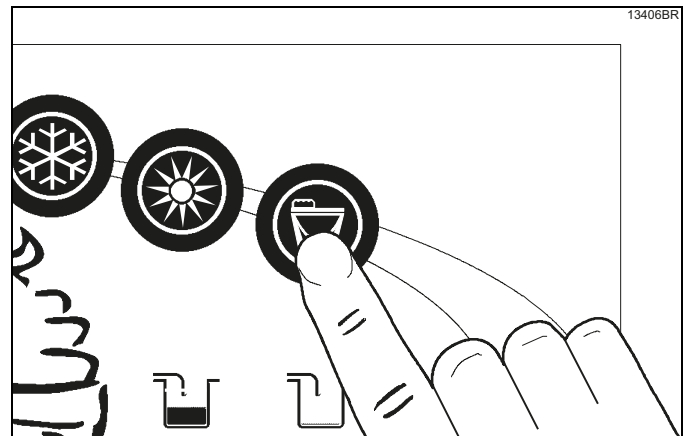



Figure 6-38

Drain the product from the freezing cylinder and mix hopper and properly dispose of the mix.

- When the flow of product stops, press the Wash key , canceling the Wash mode. Close the draw valve.
- Repeat steps 1 through 4 for the other side of

Model C717.

Rinsing

1. Pour 2 gal. (7.6 L) of cool, clean water into the mix hopper. With the white hopper brush, scrub the mix hopper mix-level sensing probes and the outside of the agitator driveshaft housing. Using the double-ended brush, brush-clean the mix inlet hole.

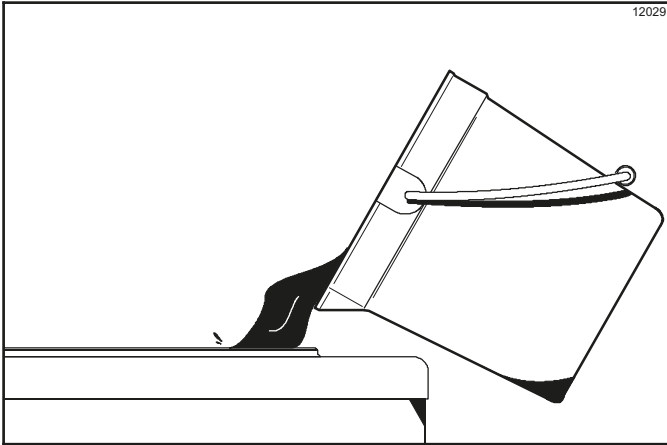



Figure 6-39

Note: Do not brush-clean the mix inlet hole while the machine is in the Wash mode.

2. With a pail beneath the door spout(s), press the Wash key .

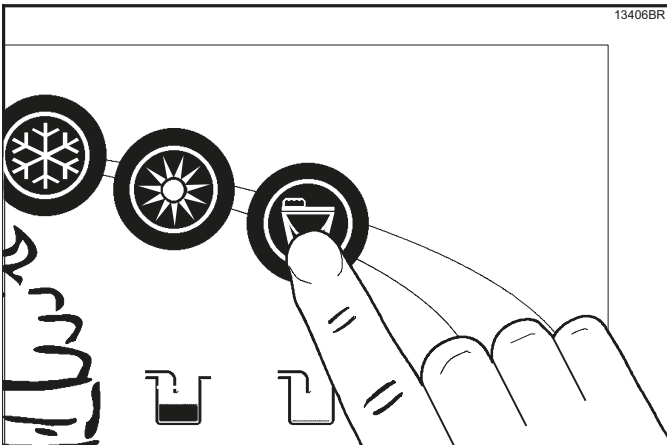



Figure 6-40

3. Open the draw valve on the freezer door. Drain all the rinse water from the door spout, close the draw valve, and press the Wash key,  canceling the Wash mode.
4. Repeat steps 1 through 3 using clean, warm water, until the water being discharged is clear.
5. Repeat steps 1 through 4 for the other side of

Model C717.



Hopper Cleaning

1. Prepare an approved 100 PPM cleaning solution (example 2-1/2 gal. [9.5 L] of Kay-5[®] or 2 gal. [7.6 L] of Stera-Sheen[®]).

Note: Use warm water and follow the manufacturer's specifications.

2. Pour the solution into the hopper and allow the solution to flow into the freezing cylinder.
3. Using the white hopper brush, clean the mix hopper, mix-level sensing probes, and outside of the agitator driveshaft housing. Using the double-ended brush, clean the mix inlet hole.

Note: Do not brush-clean the mix inlet hole while the machine is in Wash mode.

4. Press the Wash key . The cleaning solution in the freezing cylinder will contact all areas of the freezing cylinder.
5. Place an empty pail beneath the door spout(s).
6. Open the draw valve on the freezer door and draw off all the solution.
7. Once the cleaning solution stops flowing from the door spout, close the draw valve and press the Wash key , canceling the Wash mode.
8. Repeat steps 1 through 7 for the other side of Model C717.

Disassembly

Note: Failure to remove the parts specified below for brush-cleaning and lubrication will result in damage to the machine. These parts must be removed within the maximum number of days allowed between brush-clean cycles, or the machine will hard lock and will not operate.

1. Make sure the power switch is in the OFF position.
2. Remove the handscrews, freezer door, beater, scraper blades, and driveshaft with driveshaft seal from the freezing cylinder.
3. Remove the scraper blades.
4. Remove the driveshaft seal from the driveshaft.
5. Remove the freezer door gasket, front bearing, pivot pin, draw handle, and draw valve. Remove the three O-rings from the draw valve.

6. Remove the front drip tray and splash shield.
7. Remove all drip pans and take them to the sink for cleaning.

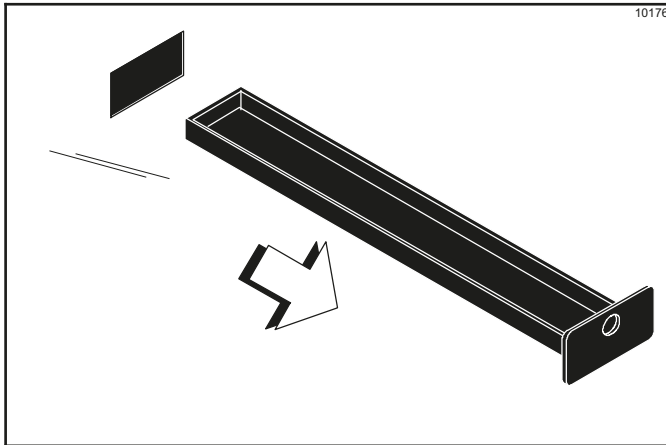

Figure 6-41

Note: If the drip pans are filled with an excessive amount of mix, the driveshaft seal(s) or O-ring(s) should be replaced or properly lubricated.

8. Repeat steps 1 through 7 for the other side of Model C717.

Brush-Cleaning

1. Prepare an approved 100 PPM cleaning solution (example 2-1/2 gal. [9.5 L] of Kay-5® or 2 gal. [7.6 L] of Stera-Sheen®).

Note: Use warm water and follow the manufacturer's specifications.

Make sure all brushes provided with the freezer are available for brush-cleaning.

2. Remove all O-rings.
3. Thoroughly brush-clean all disassembled parts in the cleaning solution, making sure all lubricant and mix film is removed. Make sure to brush all surfaces and holes, especially the draw valve hole in the freezer door.
4. Rinse all parts with clean, warm water. Place the parts on a clean, dry surface to air-dry overnight.

5. Return to the freezer with a small amount of cleaning solution. Using the black brush, clean the rear shell bearing at the back of the freezing cylinder.

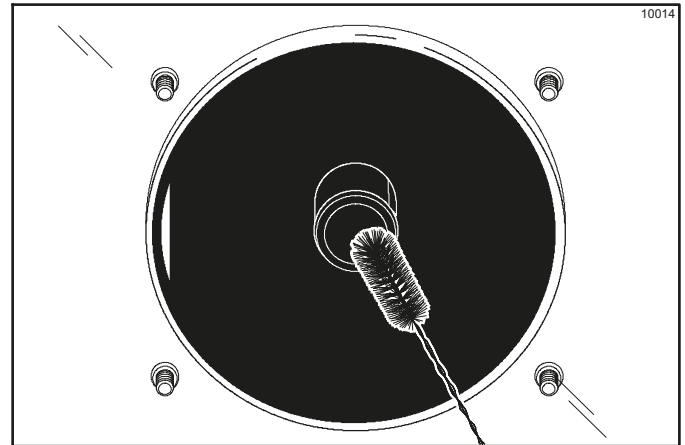

Figure 6-42

6. Repeat steps 1 through 5 for the other side of Model C717.
7. Wipe all exterior surfaces of the freezer with a clean, sanitized towel.

During Brush-Cleaning and Sanitizing



ALWAYS FOLLOW LOCAL HEALTH CODES.



NOTICE! Cleaning and sanitizing schedules are governed by your federal, state, or local regulatory agencies and must be followed accordingly. Please see the cleaning section of this manual for the proper procedure to clean this machine.

Consult your governing food code to determine the maximum number of days allowed between brush-clean cycles.

The following checkpoints should be stressed during the cleaning and sanitizing operations.

Troubleshooting Bacterial Count

- Thoroughly clean and sanitize the machine regularly, including complete disassembly and brush-cleaning.
- Use all brushes supplied for thorough cleaning. The brushes are specially designed to reach all mix passageways.
- Use the white bristle brush to clean the mix inlet hole, which extends from the mix hopper down to the rear of the freezing cylinder.
- Use the black bristle brush to thoroughly clean the rear shell bearing located at the rear of the freezing cylinder. Use a generous amount of cleaning solution on the brush.
- Properly prepare the cleaning and sanitizing solutions. Read and follow label directions carefully. Too **strong** of a solution may damage the parts, and too **weak** of a solution does **not** adequately clean or sanitize.
- The temperature of mix in the mix hopper and walk-in cooler should be below 40°F (4.4°C).

Regular Maintenance Checks

- Replace scraper blades that are nicked or damaged. Before installing the beater assembly, make sure the scraper blades are properly attached to the helix.
- Check the rear shell bearing for signs of wear (excessive mix leakage in rear drip pan) and make sure it is properly cleaned.
- Using a screwdriver and cloth towel, clean the rear shell bearing and the female hex drive socket of lubricant and mix deposits.
- Dispose of O-rings and seals if they are worn, torn, or fit too loosely, and replace with new ones.
- Follow all lubricating procedures as outlined in "Assembly" on page 6-1.
- If your machine is air-cooled or equipped with an auxiliary refrigeration system, check the condensers for dirt and lint. Dirty condensers will reduce the efficiency and capacity of the machine. Condensers should be cleaned **monthly** with a soft brush. **Never** use screwdrivers or other metal probes to clean between the fins

Note: For machines equipped with an air filter, it will be necessary to vacuum-clean the filters monthly.

Winter Storage

If the place of business is to be closed during the winter months, it is important to protect the freezer by following certain precautions, particularly if the building is subject to freezing conditions.

Disconnect the freezer from the main power source to prevent possible electrical damage.

On water-cooled freezers, disconnect the water supply. Relieve pressure on the spring in the water valve. Use air pressure on the outlet side to blow out any water remaining in the condenser. This is **extremely important**. Failure to follow this procedure may cause severe and costly damage to the refrigeration system.

Your local Taylor distributor can perform this winter storage service for you.

Wrap detachable parts of the freezer (such as the beater, blades, driveshaft, and freezer door) and place them in a protected dry place. Rubber trim parts and gaskets can be protected by wrapping them with moisture-proof paper. All parts should be thoroughly cleaned of dried mix or lubrication, which can attract mice and other vermin.

It is recommended that a Taylor service technician perform winter storage draining, to ensure all water has been removed. This guards against freezing and rupturing of the components.

Table 8-1

Problem	Probable Cause	Remedy	Page Ref.
<p>1. Soft lock message appears on display.</p>	<p>a. More than 24 hours since the last Heat cycle.</p> <p>b. The power switch is in the OFF position.</p> <p>c. The freezer was not in the Auto or Standby mode when the Heat cycle was programmed to start.</p> <p>d. Mix Out condition.</p> <p>e. The agitator is not installed.</p> <p>f. There was a power failure.</p>	<p>a. The freezer must go through a Heat cycle every 24 hours. The freezer must be disassembled and brush-cleaned or placed in a Heat cycle.</p> <p>b. Move the power switch to the ON position. The freezer must be disassembled and brush-cleaned or placed in a Heat cycle.</p> <p>c. The freezer must be in the Auto or Standby mode. The freezer must be disassembled and brush-cleaned or placed in a Heat cycle.</p> <p>d. Level of mix in hopper must be up to the fill line on the agitator paddle. The freezer must be disassembled and brush-cleaned or placed in a Heat cycle.</p> <p>e. The agitator must be cleaned and installed before starting the Heat cycle. The freezer must be disassembled and brush-cleaned or placed in a Heat cycle.</p> <p>f. Check fault messages and product temperature. Disassemble and brush-clean or initiate a Heat Treatment cycle.</p>	<p>5-5</p> <p>5-7</p> <p>5-7</p> <p>5-7</p> <p>6-9</p> <p>5-12</p>
<p>2. Hard lock message appears on display.</p>	<p>a. Brush-clean interval exceeded.</p> <p>b. A barrel or hopper thermistor is faulty.</p>	<p>a. The freezer must be disassembled and brush-cleaned within 24 hours when the counter indicates 1 day remaining.</p> <p>b. Call a service technician.</p>	<p>5-5</p> <p>---</p>

TROUBLESHOOTING GUIDE

Problem	Probable Cause	Remedy	Page Ref.
3. No product is being dispensed.	a. Low on mix. The MIX OUT light is on.	a. Add mix to the mix hopper. Return to Auto mode.	6-8
	b. The power switch is in the OFF position.	b. Move the power switch to the ON position and select Auto mode.	6-7
	c. The circuit breaker is off or the fuse is blown.	c. Turn the breaker on or replace the fuse.	---
	d. Beater motor is out on reset. BEATER OVERLOAD message appears.	d. Turn the machine off. Press the RESET button. Restart the machine in Auto mode.	---
	e. Machine is not in Auto mode.	e. Select Auto mode and allow machine to cycle off before drawing product.	6-10
	f. Feed tube not properly installed.	f. Make sure the feed tube is properly installed.	6-8
	g. Freeze-up in mix inlet hole.	g. Call a service technician.	---
	h. The beater is rotating counterclockwise when observed from the operator end.	h. Contact a service technician to correct rotation.	---
4. The product is too soft.	a. Draw rate is set too fast.	a. Adjust draw rate of 5 oz. to 7 1/2 oz. (142 g to 213 g) of product by weight in 10 seconds.	6-2
	b. Not enough airspace around machine (air-cooled machines).	b. Allow for adequate airflow across the condenser.	1-2
	c. Worn scraper blades.	c. Replace regularly.	9-1
	d. Dirty condenser (A/C).	d. Clean monthly.	7-1
	e. Mix is out of date.	e. Use only fresh mix.	---
	f. Loss of water (W/C).	f. Locate cause of water loss and correct.	7-2
	g. Viscosity needs adjustment.	g. Contact service technician.	---
5. The product is too thick.	a. Freezing cylinder not primed correctly.	a. Drain the freezing cylinder and reprime the machine.	6-8
	b. The viscosity control is set too cold.	b. Call a service technician.	---
	c. Freeze-up in mix inlet hole.	c. Call a service technician.	---
6. The mix in the hopper is too warm.	a. Hopper cover is not in position.	a. Clean and sanitize the hopper cover and place in position.	6-8
	b. The agitator is not installed.	b. Clean and sanitize the agitator and install.	6-9
	c. The hopper temperature is out of adjustment.	c. Call a service technician.	---
7. The mix in the hopper is too cold.	a. The hopper temperature is out of adjustment.	a. Call a service technician.	---
8. Mix Low and Mix Out probes are not functioning.	a. Milkstone buildup in the hopper.	a. Clean hopper(s) thoroughly.	6-7
9. Product is collecting on top of the freezer door.	a. The top O-ring on draw valve is improperly lubricated or worn.	a. Lubricate properly or replace the O-ring.	6-4

Problem	Probable Cause	Remedy	Page Ref.
10. Excessive mix leakage from door spout.	a. Missing or worn draw valve O-rings.	a. Install or replace regularly.	6-4/9-1
	b. Inadequate lubrication of draw valve O-rings.	b. Lubricate properly.	6-2/6-4
	c. Wrong type of lubricant is being used (example: petroleum-based lubricant).	c. Use the proper lubricant (example: Taylor Lube).	6-1
11. Excessive mix leakage into the rear drip pan.	a. Missing or worn seal on driveshaft.	a. Install or replace regularly.	6-1/9-1
	b. The driveshaft seal is installed inside out.	b. Install correctly.	6-1
	c. Improper lubrication of driveshaft or seal.	c. Lubricate properly.	6-1
	d. The driveshaft and beater assembly worked forward.	d. Call a service technician.	---
	e. Worn rear shell bearing.	e. Call a service technician.	---
	f. Gearbox out of alignment	f. Call a service technician.	---
12. The driveshaft is stuck in the drive coupling.	a. Mix and lubricant collected in drive coupling.	a. Brush-clean the rear shell bearing area regularly.	6-13
	b. Rounded corners of driveshaft, drive coupling, or both.	b. Call a service technician.	---
	c. Gear box is out of alignment.	c. Call a service technician.	---
13. The freezing cylinder walls are scored.	a. Missing or worn front bearing and scraper blades.	a. Install or replace the front bearing and scraper blades.	6-2
	b. The baffle rod on the freezer door is broken.	b. Replace freezer door.	6-2
	c. Beater assembly is bent.	c. Replace beater assembly.	6-2
	d. Gearbox is out of alignment.	d. Call a service technician.	---
14. The product makes a popping sound when drawn.	a. Draw rate is set too fast.	a. Adjust draw rate of 5 oz. to 7 1/2 oz. (142 g to 213 g) of product by weight in 10 seconds.	6-2
	b. Freezing cylinder not primed correctly.	b. Drain the freezing cylinder and re-prime the machine.	6-8
15. No control panel functions with power switch on.	a. Machine is unplugged.	a. Plug into wall receptacle.	---
	b. Circuit breaker off or blown fuse.	b. Turn the circuit breaker on or replace the fuse.	---
16. No freezer operation after pressing the Auto key.	a. Machine is unplugged.	a. Plug into wall receptacle.	---
	b. The circuit breaker is off or the fuse is blown.	b. Turn the circuit breaker on or replace the fuse.	---
	c. The beater motor is out on reset.	c. Reset the freezer.	5-3
17. Product is not feeding into the freezing cylinder.	a. Inadequate level of mix in the mix hopper.	a. Fill the mix hopper with mix.	6-8
	b. The mix inlet hole is frozen up.	b. The mix hopper temperature needs adjustment. Call a service technician.	---

Section 9

Parts Replacement Schedule

Table 9-1

Part Description	Every 3 Months	Every 6 Months	Annually
Scraper Blades	X		
Driveshaft Seal	X		
Freezer Door Gasket	X		
Front Bearing	X		
Draw Valve O-ring	X		
Mix Feed Tube O-ring	X		
Air Orifice O-ring	X		
White Bristle Brush, 3" x 7"		Inspect and replace if necessary.	Minimum
White Bristle Brush, 1" x 2"		Inspect and replace if necessary.	Minimum
Black Bristle Brush, 1" x 2"		Inspect and replace if necessary.	Minimum
Double-Ended Brush		Inspect and replace if necessary.	Minimum
Yellow Bristle Brush		Inspect and replace if necessary.	Minimum
Baffle-Threadless Molded		Inspect and replace if necessary.	

TAYLOR COMPANY LIMITED WARRANTY ON FREEZERS

Taylor Company is pleased to provide this limited warranty on new Taylor-branded freezer equipment available from Taylor to the market generally (the "Product") to the original purchaser only.

LIMITED WARRANTY

Taylor warrants the Product against failure due to defect in materials or workmanship under normal use and service as follows. All warranty periods begin on the date of original Product installation. If a part fails due to defect during the applicable warranty period, Taylor, through an authorized Taylor distributor or service agency, will provide a new or remanufactured part, at Taylor's option, to replace the failed defective part at no charge for the part. Except as otherwise stated herein, these are Taylor's exclusive obligations under this limited warranty for a Product failure. This limited warranty is subject to all provisions, conditions, limitations, and exclusions listed below and on the reverse (if any) of this document.

Table 10-1

Product	Part	Limited Warranty Period
Soft Serve	Insulated shell assembly	Five (5) years
Frozen Yogurt Shakes	Refrigeration compressor (except service valve)	Five (5) years
Smoothies	Beater motors	Two (2) years
Frozen Beverage	Beater drive gear	Two (2) years
Batch Desserts	Printed circuit boards and Softech controls beginning with serial number H8024200	Two (2) years
	Parts not otherwise listed in this table or excluded below	One (1) year

LIMITED WARRANTY CONDITIONS

1. If the date of original installation of the Product cannot be verified, then the limited warranty period begins ninety (90) days from the date of Product manufacture (as indicated by the Product serial number). Proof of purchase may be required at time of service.
2. This limited warranty is valid only if the Product is installed and all required service work on the Product is performed by an authorized Taylor distributor or service agency, and only if genuine, new Taylor parts are used.
3. Installation, use, care, and maintenance must be normal and in accordance with all instructions contained in the Taylor Operator's Manual.
4. Defective parts must be returned to the authorized Taylor distributor or service agency for credit.
5. The use of any refrigerant other than that specified on the Product's data label will void this limited warranty.

LIMITED WARRANTY ON EQUIPMENT

LIMITED WARRANTY EXCEPTIONS

This limited warranty does **not** cover:

1. Labor or other costs incurred for diagnosing, repairing, removing, installing, shipping, servicing, or handling of defective parts, replacement parts, or new Products.
2. Normal maintenance, cleaning, and lubrication as outlined in the Taylor Operator's Manual, including cleaning of condensers.
3. Replacement of wear items designated as Class "000" parts in the Taylor Operator's Manual.
4. External hoses, electrical power supplies, and machine grounding.
5. Parts not supplied or designated by Taylor, or damages resulting from their use.
6. Return trips or waiting time required because a service technician is prevented from beginning warranty service work promptly upon arrival.
7. Failure, damage, or repairs due to faulty installation, misapplication, abuse, no or improper servicing, unauthorized alteration, or improper operation or use as indicated in the Taylor Operator's Manual, including but not limited to the failure to use proper assembly and cleaning techniques, tools, or approved cleaning supplies.
8. Failure, damage, or repairs due to theft, vandalism, wind, rain, flood, high water, water, lightning, earthquake, or any other natural disaster, fire, corrosive environments, insect or rodent infestation, or other casualty, accident or condition beyond the reasonable control of Taylor; operation above or below the electrical or water supply specification of the Product; or components repaired or altered in any way so as, in the judgment of the Manufacturer, to adversely affect performance, or normal wear or deterioration.
9. Any Product purchased over the Internet.
10. Failure to start due to voltage conditions, blown fuses, open circuit breakers, or damages due to the inadequacy or interruption of electrical service.
11. Electricity or fuel costs, or increases in electricity or fuel costs from any reason whatsoever.
12. Damages resulting from the use of any refrigerant other than that specified on the Product's data label will void this limited warranty.
13. Any cost to replace, refill, or dispose of refrigerant, including the cost of refrigerant.
14. **ANY SPECIAL, INDIRECT, OR CONSEQUENTIAL PROPERTY OR COMMERCIAL DAMAGE OF ANY NATURE WHATSOEVER.** Some jurisdictions do not allow the exclusion of incidental or consequential damages, so this limitation may not apply to you.

This limited warranty gives you specific legal rights, and you may also have other rights which vary from jurisdiction to jurisdiction.

LIMITATION OF WARRANTY

THIS LIMITED WARRANTY IS EXCLUSIVE AND IS IN LIEU OF ALL OTHER WARRANTIES, CONDITIONS, AND/OR REMEDIES UNDER THE LAW, INCLUDING ANY IMPLIED WARRANTIES OR CONDITIONS OF MERCHANTABILITY OR FITNESS FOR A PARTICULAR PURPOSE. THE ORIGINAL OWNER'S SOLE REMEDY WITH RESPECT TO ANY PRODUCTS SHALL BE REPAIR OR REPLACEMENT OF DEFECTIVE COMPONENTS UNDER THE TERMS OF THIS LIMITED WARRANTY. ALL RIGHTS TO CONSEQUENTIAL OR INCIDENTAL DAMAGES (INCLUDING CLAIMS FOR LOST SALES, LOST PROFITS, PRODUCT LOSS, PROPERTY DAMAGES, OR SERVICE EXPENSES) ARE EXPRESSLY EXCLUDED. THE EXPRESS WARRANTIES MADE IN THIS LIMITED WARRANTY MAY NOT BE ALTERED, ENLARGED, OR CHANGED BY ANY DISTRIBUTOR, DEALER, OR OTHER PERSON, WHATSOEVER.

LEGAL REMEDIES

The owner **must** notify Taylor in writing, by certified or registered letter to the following address, of any defect or complaint with the Product, stating the defect or complaint and a specific request for repair, replacement, or other correction of the Product under warranty, mailed at least thirty (30) days before pursuing any legal rights or remedies.

Taylor Company
750 N. Blackhawk Blvd.
Rockton, IL 61072, U.S.A.

TAYLOR COMPANY LIMITED WARRANTY ON TAYLOR GENUINE PARTS

Taylor Company is pleased to provide this limited warranty on new Taylor genuine replacement components and parts available from Taylor to the market generally (the “Parts”) to the original purchaser only.

LIMITED WARRANTY

Taylor warrants the Parts against failure due to defect in materials or workmanship under normal use and service as follows. All warranty periods begin on the date of original installation of the Part in the Taylor unit. If a Part fails due to defect during the applicable warranty period, Taylor, through an authorized Taylor distributor or service agency, will provide a new or remanufactured Part, at Taylor’s option, to replace the failed defective Part at no charge for the Part. Except as otherwise stated herein, these are Taylor’s exclusive obligations under this limited warranty for a Part failure. This limited warranty is subject to all provisions, conditions, limitations, and exclusions listed below and on the reverse (if any) of this document.

Table 11-1

Parts Warranty Class Code Or Part	Limited Warranty Period
Class 103 Parts ¹	Three (3) months
Class 212 Parts ²	Twelve (12) months
Class 512 Parts	Twelve (12) months
Class 000 Parts	No warranty

LIMITED WARRANTY CONDITIONS

1. If the date of original installation of the Part cannot be otherwise verified, proof of purchase may be required at time of service.
2. This limited warranty is valid only if the Part is installed and all required service work in connection with the Part is performed by an authorized Taylor distributor or service agency.
3. The limited warranty applies only to Parts remaining in use by their original owner at their original installation location in the unit of original installation.
4. Installation, use, care, and maintenance must be normal and in accordance with all instructions contained in the Taylor Operator’s Manual.
5. Defective Parts must be returned to the authorized Taylor distributor or service agency for credit.
6. This warranty is not intended to shorten the length of any warranty coverage provided pursuant to a separate Taylor Limited Warranty on freezer or grill equipment.
7. The use of any refrigerant other than that specified for the unit in which the Part is installed will void this limited warranty.

^{1, 2} Except that Taylor Part #032129SER2 (Compressor-Air-230V SERV) and Taylor Part #075506SER1 (Compressor-Air-115V 60HZ) shall have a limited warranty period of twelve (12) months when used in Taylor freezer equipment and a limited warranty period of two (2) years when used in Taylor grill equipment.

LIMITED WARRANTY ON PARTS

LIMITED WARRANTY EXCEPTIONS

This limited warranty does **not** cover:

1. Labor or other costs incurred for diagnosing, repairing, removing, installing, shipping, servicing, or handling of defective Parts, replacement Parts, or new Parts.
2. Normal maintenance, cleaning, and lubrication as outlined in the Taylor Operator's Manual, including cleaning of condensers or carbon and grease buildup.
3. Required service, whether cleaning or general repairs, to return the cooking surface assemblies, including the upper platen and lower plate, to an operational condition to achieve proper cooking or allow proper assembly of release sheets and clips as a result of grease buildup on the cooking surfaces, including but not limited to the platen and plate, sides of the shroud, or top of the shroud.
4. Replacement of cooking surfaces, including the upper platen and lower plate, due to pitting or corrosion (or in the case of the upper platen, due to loss of plating) as a result of damage due to the impact of spatulas or other small wares used during the cooking process or as a result of the use of cleaners, cleaning materials, or cleaning processes not approved for use by Taylor.
5. Replacement of wear items designated as Class "000" Parts in the Taylor Operator's Manual, as well as any release sheets and clips for the Product's upper platen assembly.
6. External hoses, electrical power supplies, and machine grounding.
7. Parts not supplied or designated by Taylor, or damages resulting from their use.
8. Return trips or waiting time required because a service technician is prevented from beginning warranty service work promptly upon arrival.
9. Failure, damage, or repairs due to faulty installation, misapplication, abuse, no or improper servicing, unauthorized alteration, or improper operation or use as indicated in the Taylor Operator's Manual, including but not limited to the failure to use proper assembly and cleaning techniques, tools, or approved cleaning supplies.
10. Failure, damage, or repairs due to theft, vandalism, wind, rain, flood, high water, water, lightning, earthquake, or any other natural disaster, fire, corrosive environments, insect or rodent infestation, or other casualty, accident or condition beyond the reasonable control of Taylor; operation above or below the gas, electrical, or water supply specification of the unit in which a part is installed; or Parts or the units in which they are installed repaired or altered in any way so as, in the judgment of Taylor, to adversely affect performance, or normal wear or deterioration.
11. Any Part purchased over the Internet.
12. Failure to start due to voltage conditions, blown fuses, open circuit breakers, or damages due to the inadequacy or interruption of electrical service.
13. Electricity, gas, or other fuel costs, or increases in electricity or fuel costs from any reason whatsoever.
14. Damages resulting from the use of any refrigerant other than that specified for the unit in which the Part is installed will void this limited warranty.
15. Any cost to replace, refill, or dispose of refrigerant, including the cost of refrigerant.
16. **ANY SPECIAL, INDIRECT, OR CONSEQUENTIAL PROPERTY OR COMMERCIAL DAMAGE OF ANY NATURE WHATSOEVER.** Some jurisdictions do not allow the exclusion of incidental or consequential damages, so this limitation may not apply to you.

This limited warranty gives you specific legal rights, and you may also have other rights which vary from jurisdiction to jurisdiction.

LIMITATION OF WARRANTY

THIS LIMITED WARRANTY IS EXCLUSIVE AND IS IN LIEU OF ALL OTHER WARRANTIES, CONDITIONS, AND/OR REMEDIES UNDER THE LAW, INCLUDING ANY IMPLIED WARRANTIES OR CONDITIONS OF MERCHANTABILITY OR FITNESS FOR A PARTICULAR PURPOSE. THE ORIGINAL OWNER'S SOLE REMEDY WITH RESPECT TO ANY PRODUCTS SHALL BE REPAIR OR REPLACEMENT OF DEFECTIVE PARTS UNDER THE TERMS OF THIS LIMITED WARRANTY. ALL RIGHTS TO CONSEQUENTIAL OR INCIDENTAL DAMAGES (INCLUDING CLAIMS FOR LOST SALES, LOST PROFITS, PRODUCT LOSS, PROPERTY DAMAGES, OR SERVICE EXPENSES) ARE EXPRESSLY EXCLUDED. THE EXPRESS WARRANTIES MADE IN THIS LIMITED WARRANTY MAY NOT BE ALTERED, ENLARGED, OR CHANGED BY ANY DISTRIBUTOR, DEALER, OR OTHER PERSON, WHATSOEVER.

LEGAL REMEDIES

The owner **must** notify Taylor in writing, by certified or registered letter to the following address, of any defect or complaint with the Part, stating the defect or complaint and a specific request for repair, replacement, or other correction of the Part under warranty, mailed at least thirty (30) days before pursuing any legal rights or remedies.

Taylor Company
750 N. Blackhawk Blvd.
Rockton, IL 61072, U.S.A.

