

OPERATOR'S MANUAL



Model C722 Soft Serve Freezer

Original Operating Instructions

080568-M

2/22/12 (Original Publication)
(Updated 8/19/2020)

Complete this page for quick reference when service is required:

Taylor distributor: _____

Address: _____

Phone: _____

Service: _____

Parts: _____

Date of Installation: _____

Information found on the data label:

Model Number: _____

Serial Number: _____

Electrical Specs: Voltage _____ Cycle _____

 Phase _____

Maximum Fuse Size: _____ A

Minimum Wire Ampacity: _____ A

Note: Continuing research results in steady improvements; therefore, information in this manual is subject to change without notice.

Note: Only instructions originating from the factory or its authorized translation representative(s) are considered to be the original set of instructions.

© 2012 Taylor Company

080568-M

Any unauthorized reproduction, disclosure, or distribution of copies by any person of any portion of this work may be a violation of copyright law of the United States of America and other countries, could result in the awarding of statutory damages of up to \$250,000 (17 USC 504) for infringement, and may result in further civil and criminal penalties. All rights reserved.



Taylor Company
750 N. Blackhawk Blvd.
Rockton, IL 61072

Section 1: To the Installer

Installer Safety	1-1
Site Preparation	1-1
Air-Cooled Machines.....	1-1
Water Connections.....	1-2
Electrical Connections.....	1-2
Beater Rotation	1-3
Optional Carts	1-3
Refrigerant	1-4

Section 2: To the Operator

Section 3: Safety

Section 4: Operator Parts Identification

Model C722.....	4-1
Door and Beater Assembly	4-3
X69928-14S Pump A. - Mix Simplified S.S.	4-4
Accessories.....	4-5
Brushes	4-6
Optional Carts	4-7

Section 5: User Interface

Model C722.....	5-1
Symbol Definitions	5-2
Optional Feed Tube (Back-up Option)	5-4
Operating Screen Descriptions	5-4
Manager's Menu	5-5

Section 6: Operating Procedures

Assembly.....	6-1
Mix Pump Assembly.....	6-6
Sanitizing.....	6-8
Priming.....	6-9
Closing Procedure.....	6-10
Draining Product from the Freezing Cylinder	6-10
Rinsing	6-10
Hopper Cleaning	6-11
Disassembly.....	6-11
Manual Brush-Cleaning.....	6-12

Table of Contents

Section 7: Operator Checklist

During Cleaning and Sanitizing	7-1
Troubleshooting Bacterial Count	7-1
Regular Maintenance Checks.....	7-1
Winter Storage.....	7-2

Section 8: Troubleshooting Guide

Section 9: Parts Replacement Schedule

Section 10: Limited Warranty on Equipment

Section 11: Limited Warranty on Parts

The following information has been included in the manual as safety and regulatory guidelines. For complete installation instructions, please see the Installation Checklist.

Installer Safety



IMPORTANT! In all areas of the world, machines should be installed in accordance with existing local codes. Please contact your local authorities if you have any questions.

Care should be taken to ensure that all basic safety practices are followed during the installation and servicing activities related to the installation and service of Taylor® machines.

- Only Taylor service personnel should perform installation, maintenance, and repairs on Taylor machines.
- Authorized service personnel should consult OSHA Standard 29CFR1910.147 or the applicable code of the local area for the industry standards on lockout/tagout procedures before beginning any installation or repairs.
- Authorized service personnel must ensure that the proper personal protective equipment (PPE) is available and worn when required during installation and service.
- Authorized service personnel must remove all metal jewelry, rings, and watches before working on electrical equipment.



DANGER! The main power supply(s) to the machine must be disconnected prior to performing any installation, maintenance, or repairs. Failure to follow this instruction may result in personal injury or death from electrical shock or hazardous moving parts, as well as poor performance or damage to the machine.

Note: All repairs must be performed by a Taylor service technician.



WARNING! This machine has many sharp edges that can cause severe injuries.

Site Preparation

Review the area where the machine will be installed before uncrating the machine. Make sure all possible hazards to the user or equipment have been addressed.



WARNING! Only install this machine in a location where its use and maintenance is restricted to trained personnel. Failure to comply may result in personal injury.

Air-Cooled Machines

The Model C722 air-cooled machine requires a minimum of 6 in. (152 mm) on the left and right sides and 0.0 in. on the back. The C722 equipped with top air discharge that requires 6 in. (152 mm) on the left side, 0.0 in. on the right side, and 0.0 in. on the back.

This will allow for adequate air flow across the condenser. Failure to allow adequate clearance can reduce the refrigeration capacity of the freezer and possibly cause permanent damage to the compressor.

For Indoor Use Only: This machine is designed to operate indoors, under normal ambient temperatures of 70°F to 75°F (21°C to 24°C). The freezer has successfully performed in high ambient temperatures of 104° (40°C) at reduced capacities.



WARNING! This machine must **NOT** be installed in an area where a water jet or hose can be used. **NEVER** use a water jet or hose to rinse or clean the machine. Failure to follow this instruction may result in electrocution.



CAUTION! This machine must be installed on a level surface to avoid the hazard of tipping. Extreme care should be taken in moving this machine for any reason. Two or more persons are required to safely move this machine. Failure to comply may result in personal injury or damage to the machine.

The authorized installer should inspect the machine for damage and promptly report any damage to the local authorized Taylor distributor.

This machine is made using USA sizes of hardware. All metric conversions are approximate and vary in size.

Water Connections

(Water-Cooled Machines Only)

An adequate cold water supply must be provided with a hand shutoff valve. On the underside of the base pan or on the right side, two 3/8 in. IPS water connections for inlet and outlet are provided for easy hookup.

Permanently connect the machine using 1/2 in. (12.7 mm) inside diameter water lines. (Flexible lines are recommended, if local codes permit.) Depending on local water conditions, it may be advisable to install a water strainer to prevent foreign substances from clogging the automatic water valve. There will be only one water **in** and one water **out** connection. **Do not** install a hand shutoff valve on the water **out** line! Water should always flow in this order: First, through the automatic water valve; second, through the condenser; and third, through the outlet fitting to an **open trap drain**.



IMPORTANT! A backflow prevention device is required on the incoming water connection side. Please see the applicable national, state, and local codes for determining the proper configuration. Water pressure to the unit must not exceed 150 psi (1034 kPa).

Electrical Connections



IMPORTANT! In the United States, this machine is intended to be installed in accordance with the National Electrical Code (NEC), ANSI/NFPA 701987.

The purpose of the NEC code is the practical safeguarding of persons and property from hazards arising from the use of electricity. This code contains provisions considered necessary for safety.

In all other areas of the world, the machine should be installed in accordance with the existing local codes. Please contact your local authorities if you have any questions.

Each machine requires one power supply for each data label on the machine. Check the data label(s) on the machine for branch circuit overcurrent protection or fuse, circuit ampacity, and other electrical specifications.

See the wiring diagram provided inside the electrical box for proper power connections.



FOLLOW YOUR LOCAL ELECTRICAL CODES.



WARNING! This machine must be properly grounded. Failure to do so can result in severe personal injury from electrical shock.



WARNING! Avoid injury.

- **DO NOT** operate the machine unless it is properly grounded.
- **DO NOT** operate the machine with fuses larger than specified on the machine's data label.
- All repairs should be performed by an authorized Taylor service technician.
- The main power supplies to the machine must be disconnected prior to performing installation, repairs, or maintenance.
- **For Cord-Connected Machines:** Only Taylor service technicians or licensed electricians may install a plug or replacement cord on the machine.

- Machines that are permanently connected to fixed wiring and for which leakage currents may exceed 10 mA, particularly when disconnected or not used for long periods, or during initial installation, shall have protective devices to protect against the leakage of current, such as a GFI, installed by the authorized personnel to local codes.
- Stationary machines that are not equipped with a power cord and a plug or another device to disconnect the appliance from the power source must have an all-pole disconnecting device with a contact gap of at least 0.125 in. (3 mm) in the external installation.
- Supply cords used with this machine shall be oil-resistant, sheathed flexible cable not lighter than ordinary polychloroprene or other equivalent synthetic elastomer-sheathed cord (code designation 60245 IEC 57) installed with the proper cord anchorage to relieve conductors from strain, including twisting, at the terminals and protect the insulation of the conductors from abrasion.
- If the supply cord is damaged, it must be replaced by the manufacturer, service agent, or a similarly qualified person to avoid a hazard.
- Secure supply cord ground lead to machine in a location where if the cord is pulled the main power leads become taut before the ground lead can break loose.

Failure to follow these instructions may result in electrocution. Contact your local authorized Taylor distributor for service.



IMPORTANT! An equipotential grounding lug is provided with this machine. Some countries require the grounding lug to be properly attached to the rear of the frame by the authorized installer. The installation location is marked by the equipotential bonding symbol (5021 of IEC 60417-1) on both the removable panel and the machine's frame.

Beater Rotation



NOTICE! Beater rotation must be clockwise as viewed looking into the freezing cylinder.

To correct the rotation on a three-phase machine, interchange any two incoming power supply lines at the machine main terminal block only. To correct rotation on a single-phase machine, exchange leads inside the beater motor. (Follow the diagram printed on the motor.)

Electrical connections are made directly to the terminal block provided in the main control box located behind the service panel.

It is recommended that beater rotation adjustment be performed by an authorized Taylor service technician.

Optional Carts

There are two optional carts available.

- **C20600-AFB:** ADA-compliant height cart, not equipped with a door.
- **C20600-000:** Standard height cart with reversible front door panel and rear panel.

Note: If the door is required on the rear of the cart instead of the front, the front door panel and the rear panel can be reversed. To reverse these panels, remove the five screws on each panel. Reverse and re-install the panels, making sure all screws are re-installed.

Important! For safety purposes, the freezer must be bolted to the cart using all four bolts. Failure to comply could result in personnel injury and machine damage.

Refrigerant



CAUTION! This machine contains fluorinated greenhouse gases (F-Gas) to provide refrigeration using a hermetically sealed circuit or within foam insulation.

This machine's type of gas, quantity, Global Warming Potential (GWP), and CO₂ tonnes equivalent information is recorded on the machine's data label. The refrigerant used is generally considered nontoxic and nonflammable. However any gas under pressure is potentially hazardous and must be handled with caution.

NEVER fill any refrigerant cylinder completely with liquid. Filling the cylinder to approximately 80% will allow for normal expansion.



CAUTION! Use only approved refrigerant listed on the machine's data label or authorized through a manufacturer's technical bulletin. The use of any other refrigerant may expose users and operators to unexpected safety hazards.



WARNING! Refrigerant liquid sprayed onto the skin may cause serious damage to tissue. Keep eyes and skin protected. If refrigerant burns should occur, flush them immediately with cold water. If burns are severe, apply ice packs and contact a physician immediately.



NOTICE! Taylor reminds technicians to be aware of and in compliance with local government laws regarding refrigerant recovery, recycling, and reclaiming systems. For information regarding applicable local laws, please contact your local authorized Taylor distributor.



IMPORTANT! *Refrigerants and their associated lubricants may be extremely moisture absorbent. When opening a refrigeration system, the maximum time the system is open must not exceed 15 minutes. Cap all open tubing to prevent humid air or water from being absorbed by the oil.*

Your freezer has been carefully engineered and manufactured to give you dependable operation.

This machine, when properly operated and cared for, will produce a consistent quality product. Like all mechanical products, it will require cleaning and maintenance. A minimum amount of care and attention is necessary if the operating procedures outlined in this manual are followed closely.



NOTICE! *This Operator's Manual should be read before operating or performing any maintenance on your machine. Failure to follow this instruction may result in damage to the machine, poor performance, health hazards, or personal injury.*

This Operator's Manual should be read before operating or performing any maintenance on your machine.

Your Taylor freezer will **not** eventually compensate for, and correct, any errors during the setup or filling operations. Thus, the initial assembly and priming procedures are of extreme importance. It is strongly recommended that personnel responsible for the machine's operation, both assembly and disassembly, go through these procedures together in order to be properly trained and to make sure that no confusion exists.

If you require technical assistance, please contact your local authorized Taylor distributor.

Note: *Your Taylor warranty is valid only if the parts are authorized Taylor parts, purchased from the local authorized Taylor distributor, and only if all required service work is provided by an authorized Taylor service technician. Taylor reserves the right to deny warranty claims on machines or parts if Taylor-unapproved parts or incorrect refrigerant were installed in the machine, system modifications were performed beyond factory recommendations, or it is determined that the failure was caused by abuse, misuse, neglect, or failure to follow all operating instructions. For full details of your Taylor warranty, please see the Limited Warranty section in this manual.*

Note: *Constant research results in steady improvements; therefore, information in this manual is subject to change without notice.*



IMPORTANT! *If the crossed-out wheeled-bin symbol is affixed to this machine, it signifies that this machine is compliant with the EU Directives as well as other similar end-of-life legislation in effect after August 13, 2005. Therefore, it must be collected separately after its use is completed and cannot be disposed as unsorted municipal waste.*

The user is responsible for delivering the machine to the appropriate collection facility, as specified by your local code.

For additional information regarding applicable local disposal laws, please contact the municipal waste facility and/or local authorized Taylor distributor.

Compressor Warranty Disclaimer

The refrigeration compressor(s) on this machine are warranted for the term stated in the Limited Warranty section in this manual. However, due to the Montreal Protocol and the U.S. Clean Air Act Amendments of 1990, many new refrigerants are being tested and developed, thus seeking their way into the service industry. Some of these new refrigerants are being advertised as drop-in replacements for numerous applications. It should be noted that in the event of

2 ordinary service to this machine's refrigeration system, **only the refrigerant specified on the affixed data label should be used.** The unauthorized use of alternate refrigerants will void your Taylor compressor warranty. It is the machine owner's responsibility to make this fact known to any technician he/she employs.

It should also be noted that Taylor does not warrant the refrigerant used in its equipment. For example, if the refrigerant is lost during the course of ordinary service to this machine, Taylor has no obligation to either supply or provide its replacement either at billable or unbillable terms. Taylor does have the obligation to recommend a suitable replacement if the original refrigerant is banned, obsoleted, or no longer available during the five-year warranty of the compressor.

Taylor will continue to monitor the industry and test new alternates as they are being developed. Should a new alternate prove, through our testing, that then it would be accepted as a drop-in replacement, then the above disclaimer would become null and void. To find out the current status of an alternate refrigerant as it relates to your compressor warranty, call the local Taylor distributor or the Taylor factory. Be prepared to provide the model/serial number of the machine in question.

We at Taylor Company, are concerned about the safety of the operator when he or she comes in contact with the freezer and its parts. Taylor has gone to extreme efforts to design and manufacture built in safety features to protect both you and the service technician. As an example, warning labels have been attached to the freezer to further point out safety precautions to the operator.

To Operate Safely



DANGER! Failure to adhere to the following safety precautions may result in severe personal injury or death. Failure to comply with these warnings may also damage the machine and/or its components. Such damage may require component replacement and service repair expenses.



NOTICE! DO NOT operate this machine without reading this entire manual first. Failure to follow all of these operating instructions may result in damage to the machine, poor performance, health hazards, or personal injury.



IMPORTANT! *This machine is to be used only by trained personnel. It is not intended for use, cleaning, or maintenance by children or people with reduced physical, sensory, or mental capabilities or lack of experience and knowledge, unless given supervision or instruction concerning the use of the machine by a person responsible for their safety. Children should be supervised to ensure that they do not play with the machine.*



IMPORTANT! *An equipotential grounding lug is provided with this machine. Some countries require the grounding lug to be properly attached to the rear of the frame by the authorized installer. The installation location is marked by the equipotential bonding symbol (5021 of IEC 60417-1) on both the removable panel and the*

machine's frame.



WARNING! This machine must **NOT** be installed in an area where a water jet or hose can be used. **NEVER** use a water jet or hose to rinse or clean the machine. Failure to follow this instruction may result in electrocution.



WARNING! Avoid injury.

- **DO NOT** operate the machine unless it is properly grounded.
- **DO NOT** operate the machine with fuses larger than specified on the machine's data label.
- All repairs should be performed by an authorized Taylor service technician.
- The main power supplies to the machine must be disconnected prior to performing installation, repairs, or maintenance.
- **For Cord-Connected Machines:** Only Taylor service technicians or licensed electricians may install a plug or replacement cord on the machine.
- Machines that are permanently connected to fixed wiring and for which leakage currents may exceed 10 mA, particularly when disconnected or not used for long periods, or during initial installation, shall have protective devices to protect against the leakage of current, such as a GFI, installed by the authorized personnel to local codes.
- Stationary machines that are not equipped with a power cord and a plug or another device to disconnect the appliance from the power source must have an all-pole disconnecting device with a contact gap of at least 0.125 in. (3 mm) in the external installation.
- Supply cords used with this machine shall be oil-resistant, sheathed flexible cable not lighter than ordinary polychloroprene or other equivalent synthetic elastomer-sheathed cord (code designation 60245 IEC 57) installed with the proper cord anchorage to relieve conductors from strain, including twisting, at the terminals

and protect the insulation of the conductors from abrasion.

- If the supply cord is damaged, it must be replaced by the manufacturer, service agent, or a similarly qualified person to avoid a hazard.
- Secure supply cord ground lead to machine in a location where if the cord is pulled the main power leads become taut before the ground lead can break loose.

Failure to follow these instructions may result in electrocution. Contact your local authorized Taylor distributor for service.

3



WARNING! Avoid injury.

- **DO NOT** allow untrained personnel to operate this machine.
- **DO NOT** operate the machine unless all service panels and access doors are restrained with screws.
- **DO NOT** remove any internal operating parts (including, but not limited to, machine door, beater, or scraper blades), unless all control switches are in the OFF position.

Failure to follow these instructions may result in severe personal injury, especially to fingers or hands, from hazardous moving parts.



WARNING! This machine has many sharp edges that can cause severe injuries.

- **DO NOT** put objects or fingers in the door spout. This may contaminate the product and cause severe personal injury from blade contact.
- **USE EXTREME CAUTION** when removing the beater assembly. The scraper blades are very sharp.
- **CAUTION-SHARP EDGES:** Two people are required to handle the cup/cone dispenser. Protective gloves must be worn, and the mounting holes must **not** be used to lift or hold the dispenser. Failure to follow this instruction can result in personal injury to fingers or equipment damage.



IMPORTANT! Access to the service area of the machine must be restricted to persons having knowledge and practical experience with the machine, in particular as far as safety and hygiene are concerned.



WARNING! Only install this machine in a location where its use and maintenance is restricted to trained personnel. Failure to comply may result in personal injury.



CAUTION! This machine must be placed on a level surface. Extreme care should be taken when moving it for any reason. Two or more persons are required to safely move this machine. Failure to comply may result in personal injury or damage to the machine.



NOTICE! Cleaning and sanitizing schedules are governed by your federal, state, or local regulatory agencies and must be followed accordingly. Please refer to the cleaning section of this manual for the proper procedure to clean this machine.



CAUTION! This machine is equipped with a refrigerated cabinet, designed to maintain product temperature at or below 41°F (5°C). Before replenishing the mix supply, the product must be refrigerated at or below 41°F (5°C). Failure to follow this instruction may result in health hazards and poor machine performance.

DO NOT run the machine without product. Failure to follow this instruction can result in damage to the machine.

DO NOT obstruct air intake and discharge openings. A minimum of 3 in. (76 mm) of air clearance on both sides of the machine is required. It is recommended to place the rear of the machine against the wall to prevent the recirculation of warm air. Failure to follow this instruction may cause poor machine performance and damage to the machine.

For Indoor Use Only: This machine is designed to operate indoors, under normal ambient temperatures of 70°F to 75°F (21°C to 24°C). The machine has successfully performed in high ambient temperatures of up to 104°F (40°C) at reduced capacities.

Noise Level: Airborne noise emission does not exceed 78 dB(A) when measured at a distance of 39 in. (1.0 m) from the surface of the machine and at a height of 62 in. (1.6 m) from the floor.

Model C722

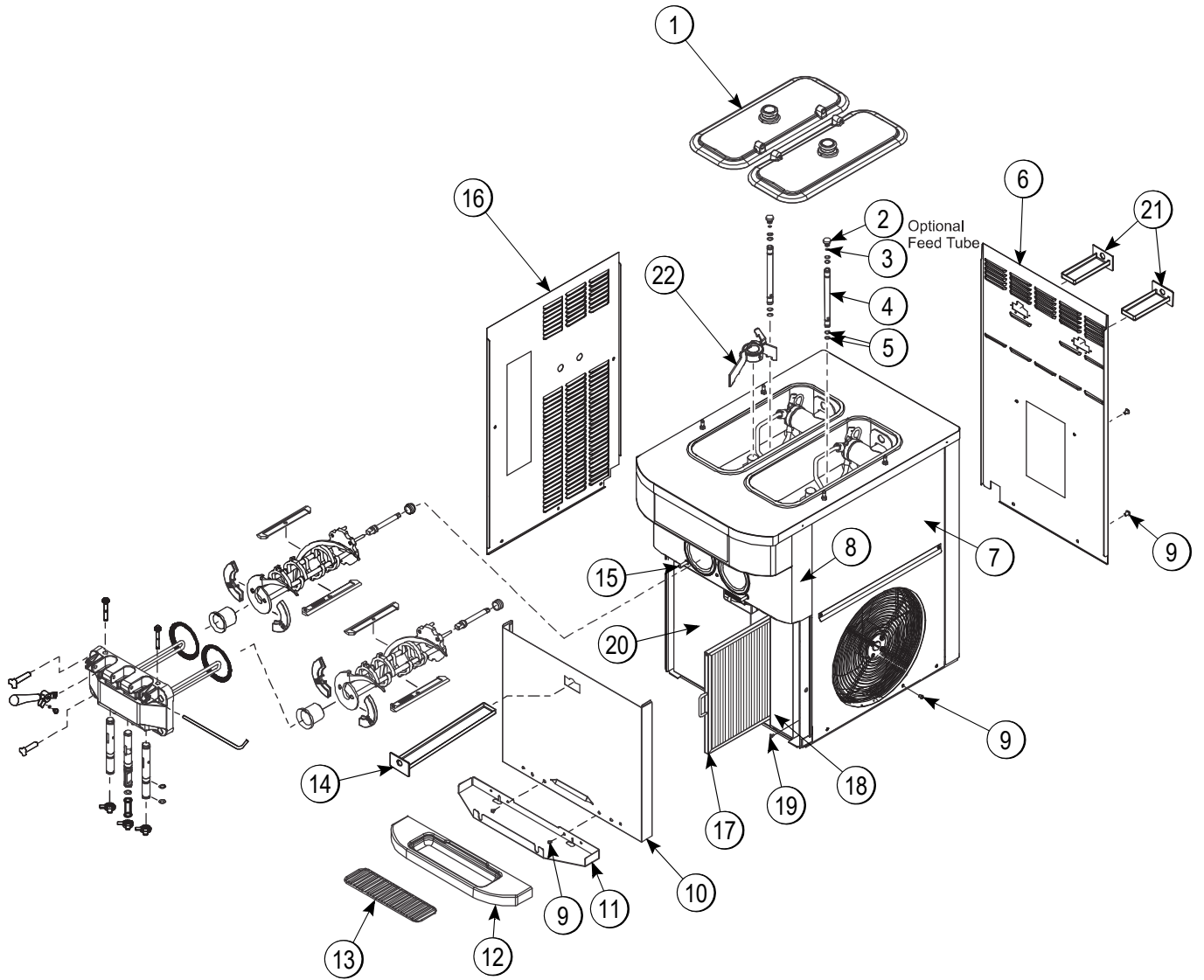

Figure 4-1

OPERATOR PARTS IDENTIFICATION

Model C722 Exploded View Parts Identification

Item	Description	Part No.
1	Kit A.-Hopper CVR 14 QT BLA	X69146
**2	Orifice	022465-100
**3	O-ring-11/16 OD X .103W Red	016132
**4	Tube A.-Feed-SS-5/32 Hole	X29429-2
**5	O-ring-.643 OD X .077W	018572
6	Panel-Rear	080162
7	Panel A.-Side Right	X68854
8	Panel A.-Front	X81843
9	Screw-1/4-20X3/8 Slotted	011694
10	Panel A.-Front-Lower	X81841
11	Shelf-Drip Tray	080782
12	Tray-Drip	080781

Item	Description	Part No.
13	Shield-Splash-Wire	046177-SP
14	Pan A.-Drip 15 1/8 Long	X51601
15	Stud-Nose Cone	055987
16	Panel-Side Left	068851
17	Filter A.	X81440
17A	Filter-Air-18.28X15.5X.70	052779-15
18	Cover-Access-Front-R.	056933
19	Screw-10x3/8 Slotted Hex	015582
20	Cover-Access-Left	081834
21	Pan-Drip-Rear	080226
*22	Blade A.-Agitator	X56591-SP

*Factory-equipped agitator units only

**Optional Feed Tube

4

Door and Beater Assembly

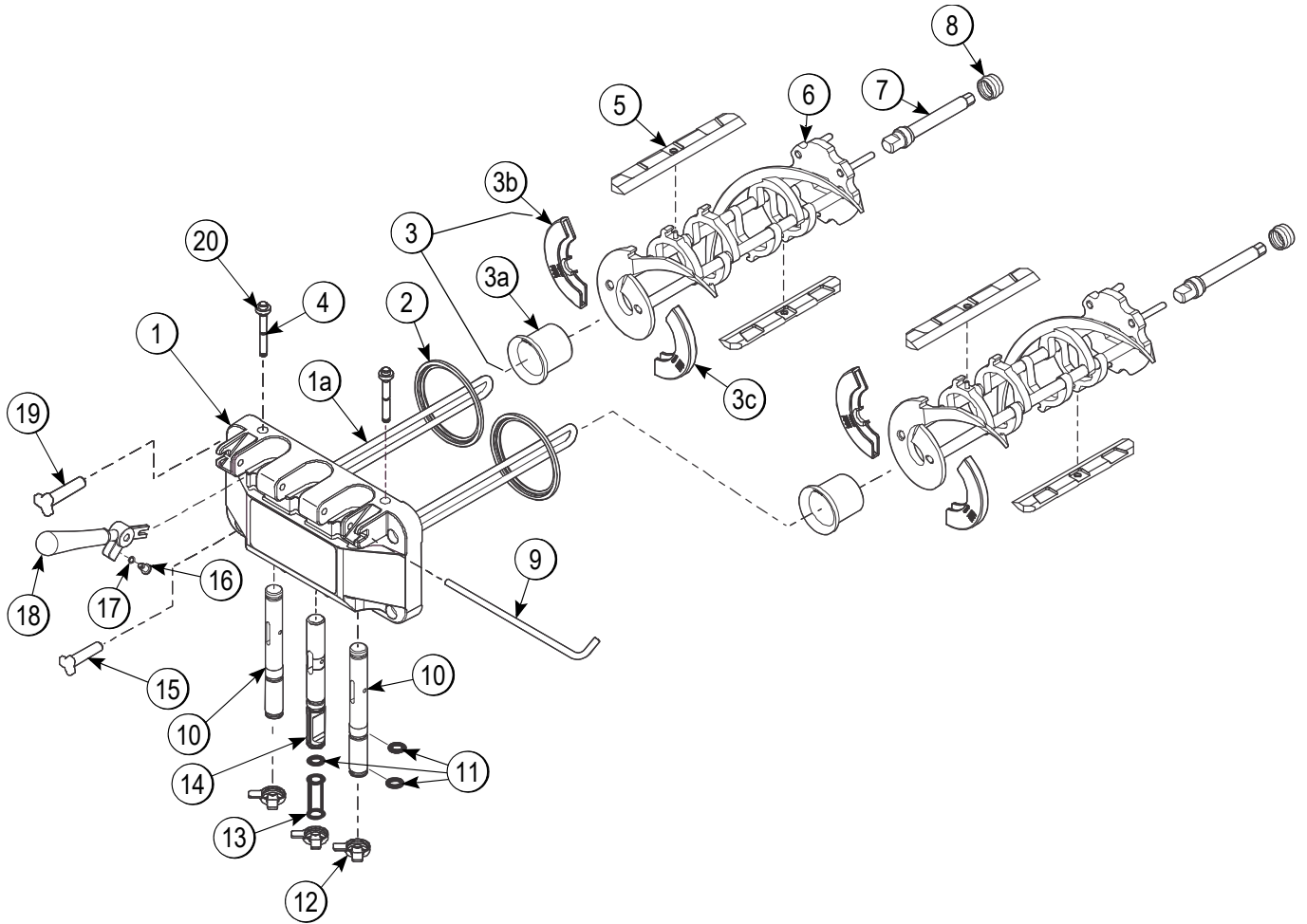

4

Figure 4-2

Item	Description	Part No.
1	Door A.-SH BAF-w/PRG	X68889-SER
1a	Baffle A.-Short 4"	X50883
2	Gasket-Door HT 4"-Double	048926
3	Kit A.-Beater-Front Shoes-Bearing	X50350
3a	Bearing-Front Shoe	*See Note
3b	Shoe-Front Helix-Front	*See Note
3c	Shoe-Front Helix-Rear	*See Note
4	O-ring-1/2OD X .070W	024278
5	Blade-Scraper-Plastic	084978
6	Beater A.-2.8QT-1 Pin	X80291
7	Shaft-Beater	081707
8	Seal-Drive Shaft	032560

Item	Description	Part No
9	Pin-Handle-Twin	059894
10	Valve A.-Draw	X69615
11	O-ring-7/8 OD X .103W	083693
12	Cap-Design 1.010"ID-6 Point	014218
13	Seal-Draw Valve-Large H	034698
14	Valve A.-Draw-Center	X62218
15	Nut-Stud-Black 2.563 Long	058764
16	Screw-Adjustment-5/16-24	056332
17	O-ring-1/4 OD X .070W	015872
18	Handle A.-Draw	X56421-1
19	Nut-Stud-Black 3.250 Long	058765
20	Plug-Prime Twin	059936

*Not available separately. Order [X50350](#) kit.

X69928-14S Pump A. - Mix Simplified S.S.

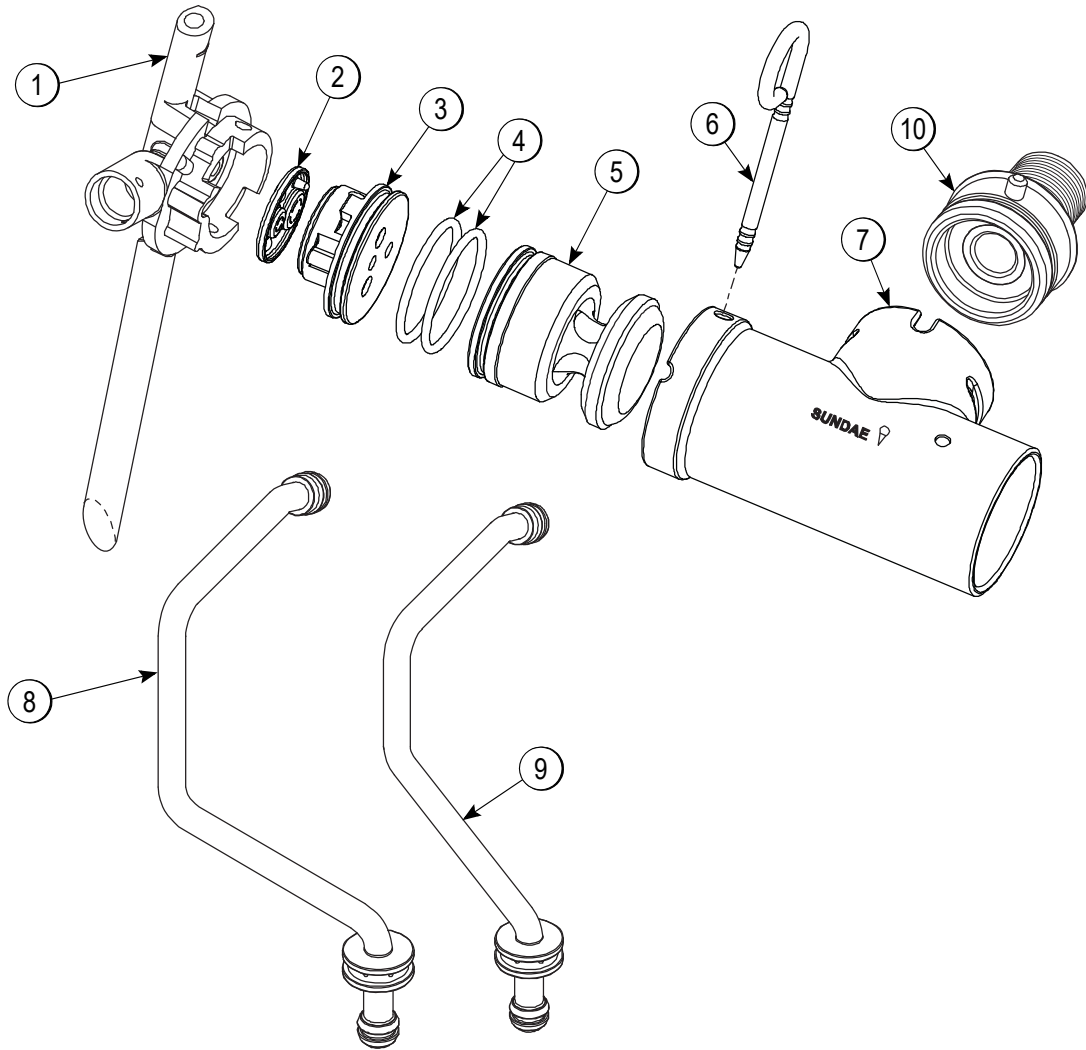

Figure 4-3

Item	Description	Part No.
1-7	Pump A.-Mix Simplified S.S.	X69928-14S
1	Adaptor-Mix Inlet-SS-Red	069921
2	Gasket-Simplified Pump Valve	086097
3	Cap-Valve Body SS	056874-14
4	O-ring-2-1/8 OD X .139W-#225	020051
5	Piston-Pump-Simpl.-Short	069922

Item	Description	Part No.
6	Pin-Retaining	X55450
7	Cylinder-Pump Hopper Softserve	069920
8	Tube A.-Feed-Left *C722*	X69919
9	Tube A.-Feed-Right *C722*	X69924
10	Sleeve A.-Mix Pump *HT*	X44761

Accessories

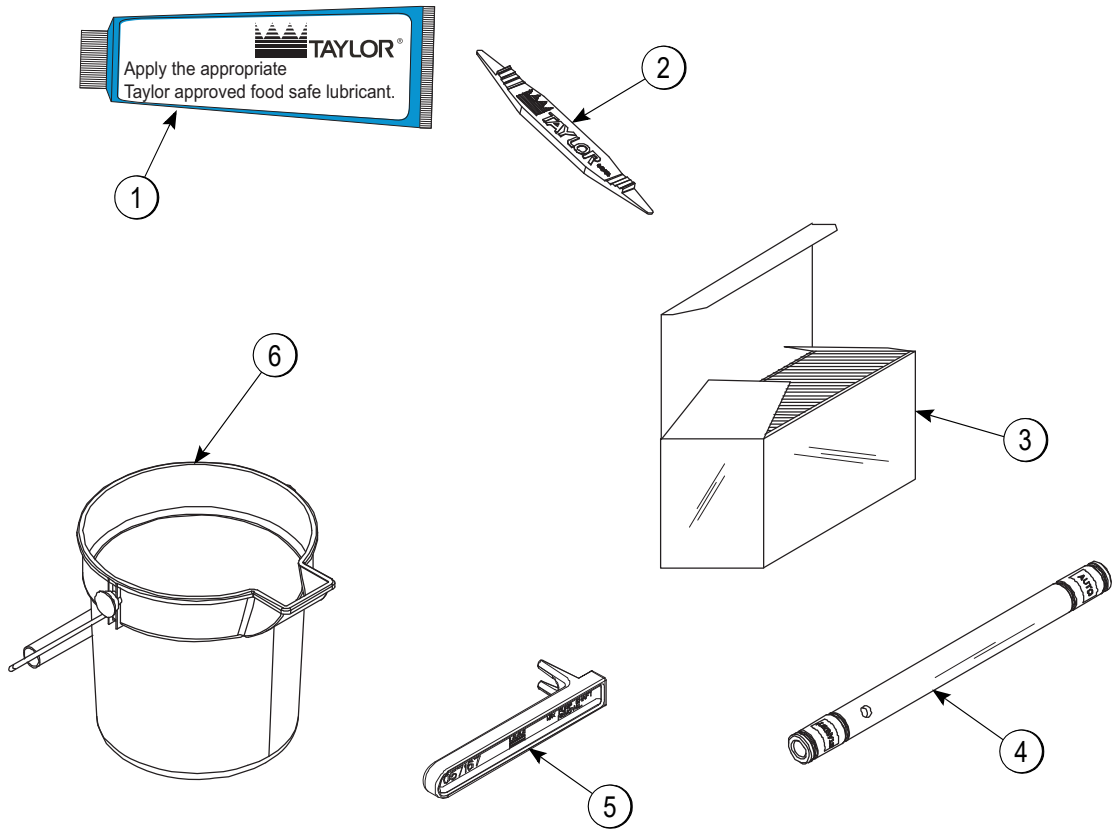

Figure 4-4

Item	Description	Part No.
1	Lubricant-Taylor	047518
2	Tool-O-ring Removal	048260-WHT
*3	Sanitizer-Stera Sheen	See Note
***4	Tube A.-Feed-SS-5/32 Hole	X29429-2

Item	Description	Part No.
5	Tool-Mix Pump Shaft Removal	057167
6	Pail-10 QT	013163
**	Kit A.-Tune	X49463-97

*A sample container of sanitizer is sent with the machine. For reorders, order Stera Sheen® part no. 055492 (100 2 oz. packs) or Kay-5® part no. 041082 (200 packs).

**Not Shown.

***Optional Feed Tube.

Brushes

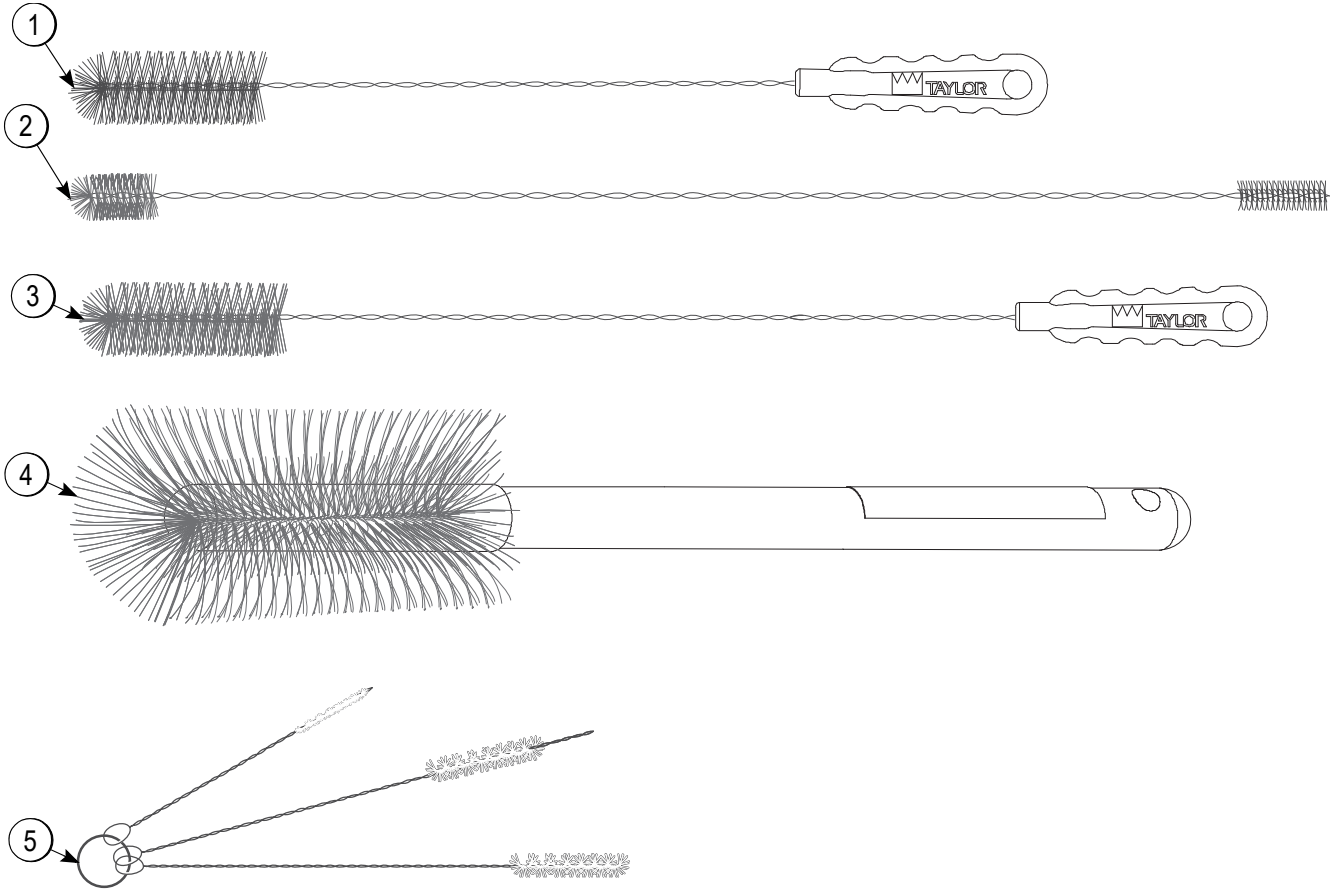

Figure 4-5

Item	Description	Part No.
1	Brush-Rear BRG. - 1" X 2"	013071
2	Brush-Double End	013072
3	Brush-Draw Valve 1 X 2 X 17	013073

Item	Description	Part No.
4	Brush-Mix Pump Body- 3 X 7	023316
5	Brush-Set LVB	050103

Optional Carts

**Cart A.-ADA X69400
C20600-AFB**

**Cart A.-Std. X69425
C20600-000**

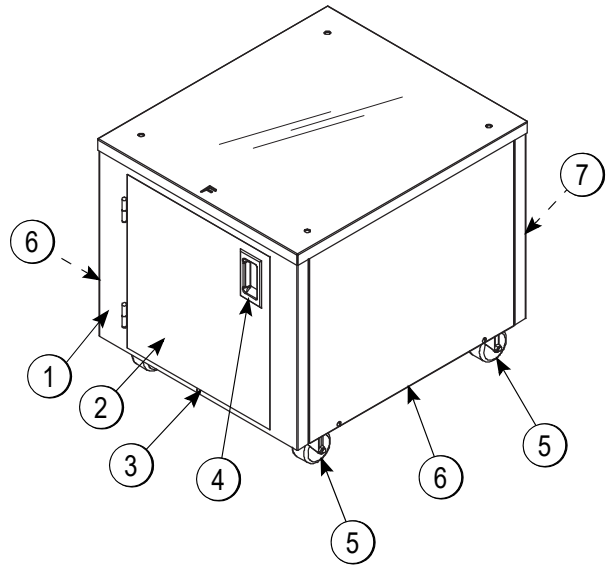
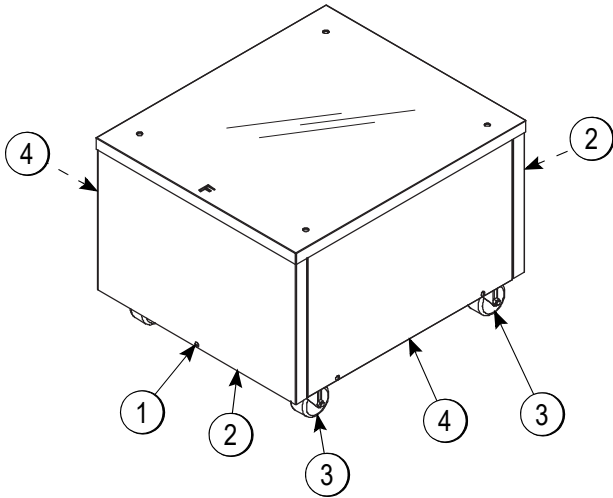

Figure 4-6

4

Item	Description	Part No.
	Cart A.-ADA	X69400
1	Screw-10-32 X 1/2 SLTD	037734
2	Panel-Front/Rear-ADA	069402
3	Caster-3" SWV 3/4-10 Stem w/Brake	030307
4	Panel-Side-Cart	069403

Note: This is an ADA-compliant height cart, not equipped with a door.

Item	Description	Part No.
	Cart A.-STD	X69425
1	Panel A.-STD Cart-Front	X69426
2	Door A.-STD Cart	X69295
3	Screw-10-32 X 1/2 SLTD TRUS	037734
4	Handle-STNLS Flush Pull	019043
5	Caster-3" SWV 3/4-10 Stem w/Brake	030307
6	Panel-Side-STD Cart	069428
7	Panel-Rear-STD Cart	069429

Note: This is a standard-height cart with reversible front door panel and rear panel.

Model C722

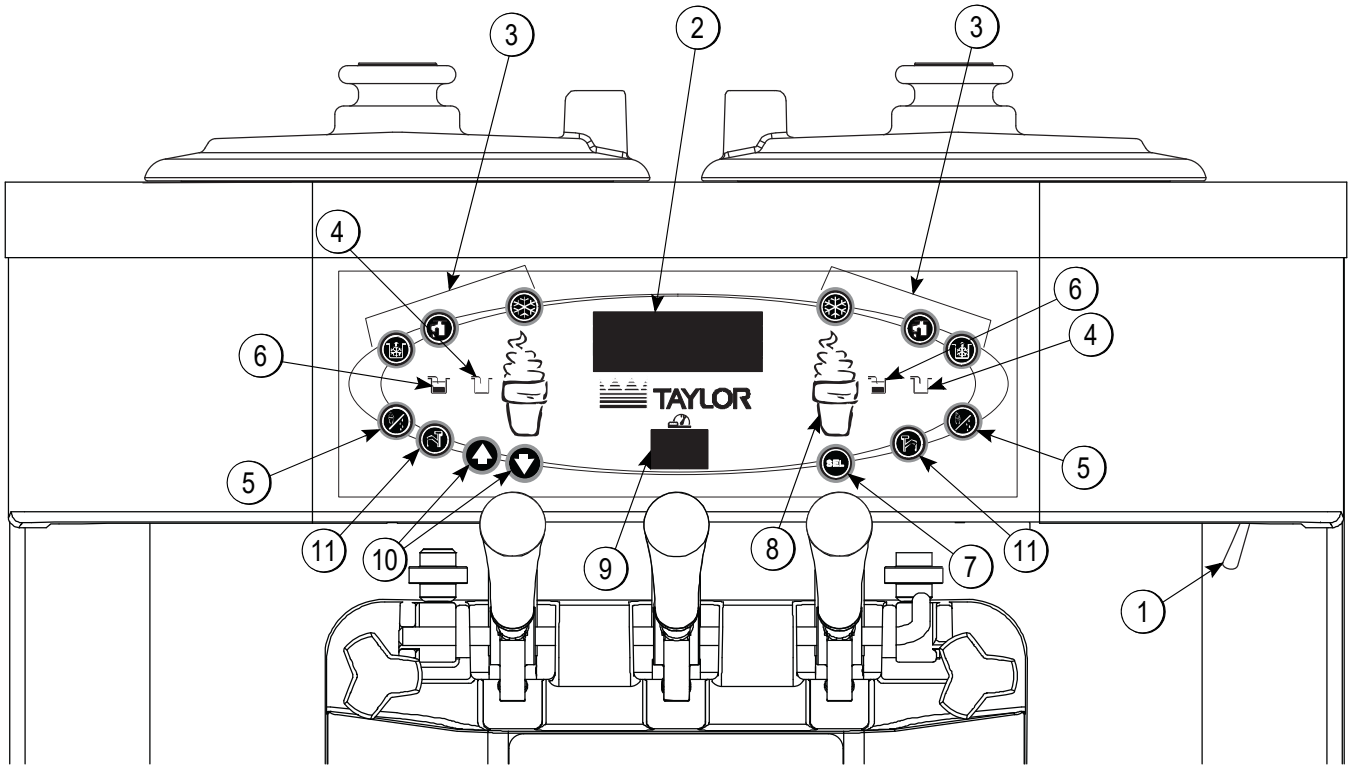

5

Figure 5-1

Item	Description
1	Power Switch
2	Liquid Crystal Display
3	Keypads
4	Mix Out Indicators
5	Standby Indicators
6	Mix Low Indicators
7	Select Key
8	Service Menu Key
9	Brush Clean Counter
10	Arrow Keys
11	Topping Heater Keys (not functional)

Symbol Definitions

To better communicate in the international arena, symbols have replaced words on many of our operator switches, function, and fault indicators. Your Taylor machine is designed with these international symbols.

The following chart identifies the symbol definitions.



= Select



= ON



= OFF



= Up Arrow



= Down Arrow



= Auto



= Wash



= Mix Low



= Mix Out



= Menu Display



= Mix Pump



= Standby



= Topping Heater-Left



= Topping Heater-Right

Power Switch



When placed in the ON position, the power switch allows control panel operation.

Liquid Crystal Display

The Liquid Crystal Display (LCD) is located on the front control panel. During normal operation, the display is blank. The display is used to show menu options and notify the operator if a fault is detected. On international models, the display will indicate the temperature of the mix in the hopper.

Indicator Lights

Mix Low—When the Mix Low symbol  illuminates, the mix hopper has a low supply of mix and should be refilled as soon as possible.



Mix Out—When the Mix Out  symbol illuminates, the mix hopper is almost completely exhausted and has an insufficient supply of mix to operate the freezer. At this time, the Auto mode is locked out and the freezer will be placed in the Standby mode. To initiate the refrigeration system, add mix to the mix hopper and press the Auto symbol  key. The freezer will automatically begin operation.

Optional feature: Some freezers are equipped with rear indicator lights.

Standby Symbol

During long **no sale** periods, the machine can be placed in Standby mode. This maintains product temperatures below 40°F (4.4°C) in both the hopper and the freezing cylinder and helps prevent overbeating and product breakdown.

To activate Standby mode, press the Standby symbol

 key or enter the access code for the Manager's Menu and select the Standby mode option (see pages 5-5 and 5-7). The Standby symbol  will illuminate, indicating the Standby feature has been activated.

Note: To resume normal operation, press the Auto symbol  key. When the machine cycles off, the product in the freezing cylinder will be at serving viscosity.

Wash Symbol

The Wash symbol  will illuminate when pressed. This indicates beater motor operation. The Standby or Auto modes must be canceled first to activate the Wash mode.

Auto Symbol

The Auto symbol  will illuminate when pressed. This indicates that the refrigeration system has been activated. In the Auto mode, the Wash or Standby functions are automatically canceled.

Note: An indicating light will illuminate and a tone will sound whenever a mode of operation has been selected. To cancel any function, press the key again. The light and the mode of operation will shut off.

Topping Heater Symbols

The Topping Heater symbols are not functional on the Model C722.



Reset Mechanism

The reset buttons are located in the left side panel of the machine. They protect the beater motors from overloading. Should an overload occur, the reset mechanism will trip. To properly reset the freezer, place the power switch in the OFF position. Press the reset button firmly. Turn the power switch to the ON position.

Press the Wash symbol  and observe the freezer's performance.



CAUTION! DO NOT use metal objects to press the reset button. Failure to follow this instruction may result in electrocution.

If the beater motor is turning properly, press the Wash symbol  to cancel the cycle. Press the Auto symbol  to resume normal operation. If the freezer shuts down again, contact your authorized service technician.

Adjustable Draw Handle

This machine features an adjustable draw handle to provide the best portion control, giving a better, consistent quality to your product and controlling costs. The draw handle should be adjusted to provide a flow rate of 5 oz. to 7-1/2 oz. (148 ml to 222 ml) of product by weight per 10 seconds. To **increase** the flow rate, tighten the screw. To **decrease** the flow rate, loosen the screw. (See Figure 5-2.)

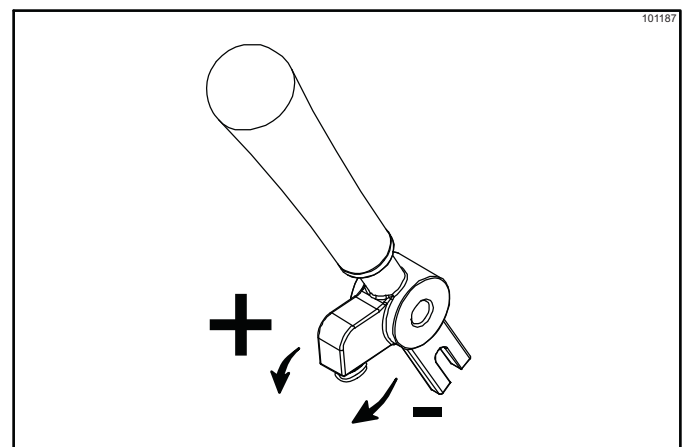

Figure 5-2

Optional Feed Tube (Back-up Option)

If the air/mix pump has become inoperable because of a missing or damaged part, the operator can temporarily operate the unit using the feed tube. The product ejection rate will be slower when the feed tube is used instead of the air/mix pump.

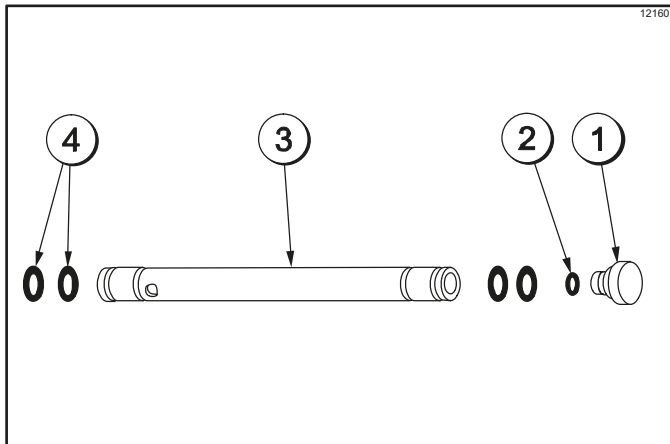

Figure 5-3

Item	Description	Part No.
1	Orifice	022465-100
2	O-ring-3/8 OD X .070 W	016137
3	Tube A.-Feed-SS 5/32 Hole	X29429-2
4	O-ring-.643 OD X .077 W	018572

The feed tube serves two purposes. One end of the tube has a hole and the other end does not.

1. Normal Operation

During normal operation, the end of the feed tube with the hole is placed into the mix inlet hole. Every time the draw handle is raised, new mix and air from the hopper flow into the freezing cylinder. This keeps the freezing cylinder properly loaded and maintains overrun.

2. Long “No Sale” Periods

During long “No Sale” periods, the unit can be placed into the Standby mode. This maintains product temperatures below 40°F (4.4°C) in both the hopper and the freezing cylinder, and helps prevent over-beating and product breakdown.

To place the unit into the Standby mode, press the STANDBY key. Remove the air orifice. Lubricate the o-rings located on the end of the feed tube without the hole. Place that end of the tube into the mix inlet hole.

This will prevent any mix from entering the freezing cylinder.

Note: The air orifice is used to meter a certain amount of air into the freezing cylinder. The air orifice maintains overrun and allows enough mix to enter the freezing cylinder after a draw.

Operating Screen Descriptions

The LCD located in the center of the control panel is normally blank during the daily operation of the machine. The display is activated when the SEL symbol or the Manager's Menu is selected. The display screen will also alert the operator of specific faults detected by the control.

Power Up

When the machine is powered, the control system will initialize to perform a system check. The screen will display INITIALIZING. There are four types of data the system will check: LANGUAGE, SYSTEM DATA, CONFIG DATA, and LOCKOUT DATA.

If the system detects corrupt data during “initializing.....,” the detected faults will be displayed for acknowledgment after the SAFETY TIMEOUT display, if the power switch is on. The faults may be CORRUPTED LANGUAGE, CONFIG CRC ERR, SYSTEM CRC ERR, FAULT HISTORY, LOCKOUT CRC ERR, or POWER FAILURE.

Once the system has initialized, the number of days remaining before the next required brush-cleaning is indicated on the control panel and the SAFETY TIMEOUT screen is displayed with the alarm turned on.

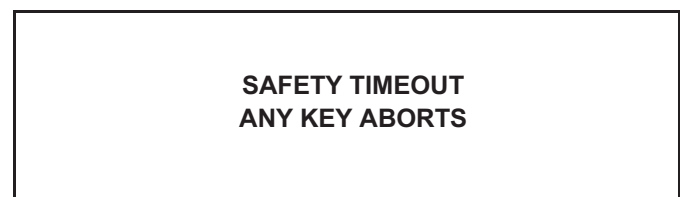

The SAFETY TIMEOUT screen will be displayed with the alarm on for 60 seconds, or until any control symbol is selected.

After the safety timeout has been completed and the power switch is off, the following screen is displayed.

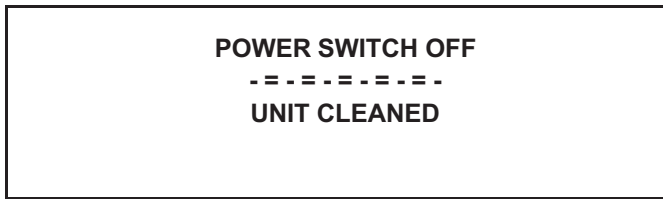

Power Switch ON

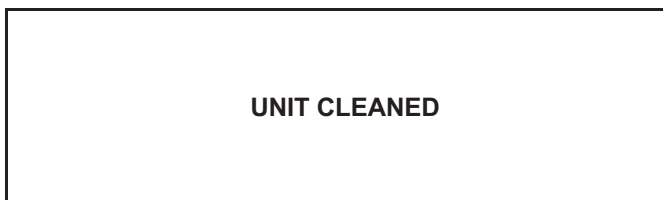

When the power switch is placed in the ON position, the control panel press keys become operative. The fluorescent display will be either be blank or will indicate that the machine has been cleaned.



Brush-Clean Counter

The brush-clean counter (item 9 on page 5-1) will display the number of hours since the freezer was last brush-cleaned. After hour 99, it will change to a letter and a number (example: A0, A1, ... B0, B1, etc.).

Manager's Menu

The Manager's Menu is used to enter the operator function displays. To access the Manager's Menu, press the center of the Cone symbol  (Menu Display) on the control panel on the right side of the machine. The arrow symbols, the SEL symbol, and the Cone symbol  (Menu Display) will be lit when the ACCESS CODE screen is displayed. (See Figure 5-4.)

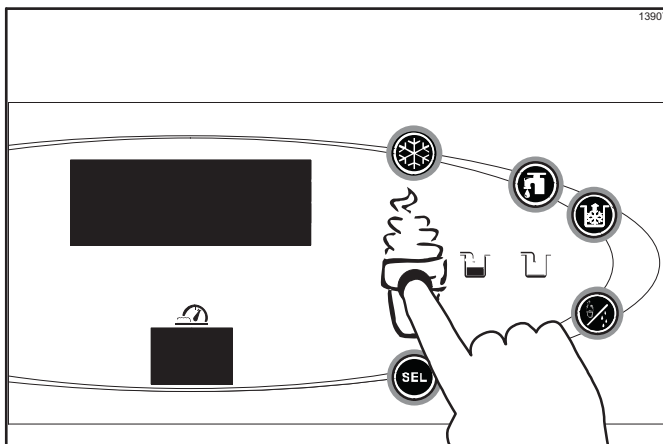

Figure 5-4

In the Menu program, the arrow symbols and the SEL symbol will function as menu keys.

Up Arrow—Increases the value above the cursor and is used to scroll upward in text displays.

Down Arrow—Decreases the value above the cursor and is used to scroll downward in text displays.

SEL—Advances the cursor position to the right and is used to select menu options.

Note: *The machine will continue operation in the mode it was in when the menu was selected. However, the control keys will not be lit and are nonfunctional when the Manager's Menu is displayed.*

Entering Access Code

With the ACCESS CODE screen on the display, use the SEL symbol to set the first code number in the cursor position. When the correct number is selected, press the SEL symbol to move the cursor to the next number position.

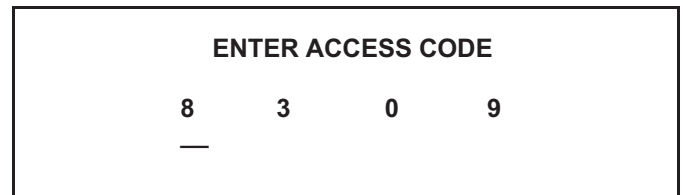

5

Continue to enter the proper access code numbers (8309) until all four numbers are displayed, and then press the SEL symbol. The Manager's menu list will display on the screen, provided the correct access code is entered.

If an incorrect number is entered for the access code, the display will exit the Menu program when the SEL symbol is selected. (See Figure 5-5.)



Figure 5-5

Menu Options

Press the **Arrow** symbols to move up or down through the Menu. Select a Menu option by pressing the SEL symbol. Exit the Menu program by selecting EXIT FROM MENU or press the Cone symbol  (Menu Display).

The following menu options are listed in the Manager's Menu.

- EXIT FROM MENU
- SERVINGS COUNTER
- SET CLOCK
- AUTO START TIME
- STANDBY MODE
- MIX LEVEL AUDIBLE
- FAULT DESCRIPTION
- FAULT HISTORY
- LOCKOUT HISTORY
- SYSTEM INFORMATION
- CURRENT CONDITIONS
- NET SERVICE PIN

Selecting EXIT FROM MENU will exit the Manager's Menu and then return the control panel symbols to normal operation.

The SERVINGS COUNTER screen is used to reset the servings counter to zero.

Note: *The SERVINGS COUNTER automatically resets to zero when the machine is brush-cleaned.*

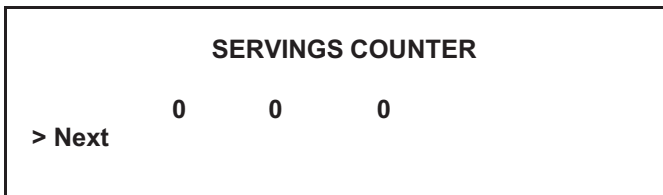

Reset the SERVINGS COUNTER by selecting the SEL symbol to advance to the next screen. Select the Up Arrow symbol to move the Arrow cursor(>) to **Yes** and press the SEL symbol. The SERVINGS COUNTER will reset to zero and exit back to the Manager's Menu.

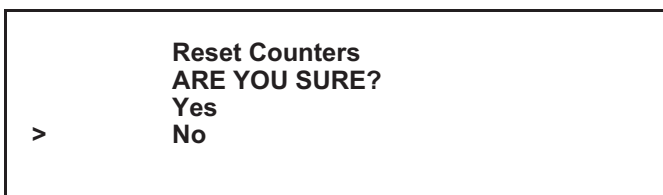

The SET CLOCK screen allows the Manager to adjust the control clock date and time. The date and time may only be changed after the freezer has been manually cleaned, but before it has been placed in the Auto or Standby mode. The following message will be displayed if the SET CLOCK option is selected when the machine is not in a brush-clean state.



To change the date or time, select the SET CLOCK option in the menu. Press the Up Arrow symbol to advance the arrow cursor from **Exit** to **Change**, then press the SEL symbol to select the Change option.



Change the time by pressing the Up Arrow symbol with the cursor under the hour position. Move the cursor to the minutes position by pressing the SEL symbol. Once the correct minutes are entered, press the SEL symbol to advance the cursor to the month.



Enter the correct month, day, and year. After they have been entered, press the SEL symbol to advance to the DAYLIGHT SAVING TIME (DST) screen.



Pressing the Up or Down Arrow symbols will move the arrow to **Enable** or **Disable**. Pressing the SEL symbol next to **Disable** selects that option and returns to the Manager Menu. Pressing the SEL symbol next to **Enable** selects that option and displays the second screen.

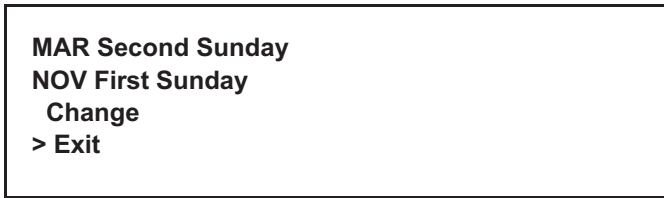

If the correct Sunday for the time change is not displayed, then **Change** should be selected. Pressing the SEL symbol with the arrow cursor next to **Change** displays the third screen. Press the Up or Down Arrow symbol to move the arrow cursor to the appropriate month for the start of DST.

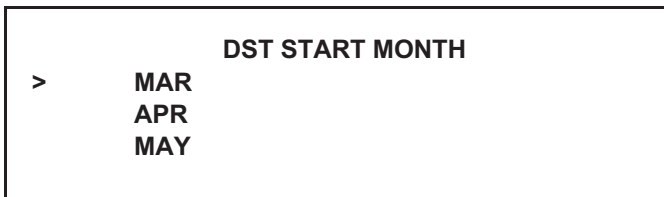

Pressing the SEL symbol with the arrow cursor next to the appropriate month will display the following screen.



Pressing the Up or Down Arrow symbol will move the arrow cursor to the appropriate week for the start of DST. Pressing the SEL symbol next to the appropriate week will display the following screen. Press the up or down Arrow symbol to move the arrow cursor to the appropriate month for the end of DST.

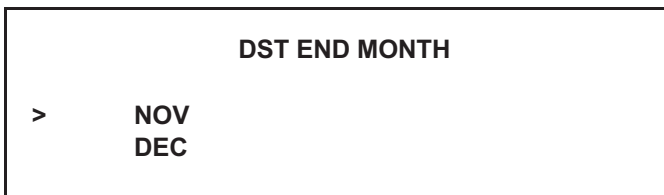

Pressing the SEL symbol next to the appropriate month will display the following screen. Press the Up or Down Arrow symbol to move the cursor to the appropriate week for the end of DST.

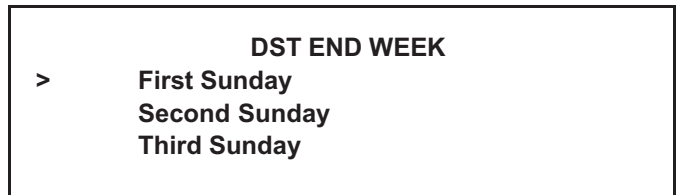

Pressing the SEL symbol with the cursor by the appropriate week will select that setting and return to the Manager's Menu.

The AUTO START TIME option allows the manager to set the time of day at which the machine automatically enters the Auto mode from the Standby mode. The machine must be in the Standby mode in order to Auto start at the programmable time. The AUTO START TIME can also be disabled and require starting the Auto mode manually.

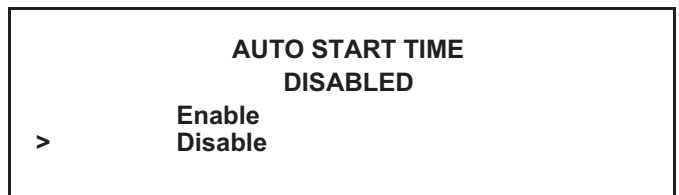

Enable the AUTO START TIME by selecting the Up Arrow symbol to move the cursor to **Enable**. Press the SEL symbol to advance to the next screen.

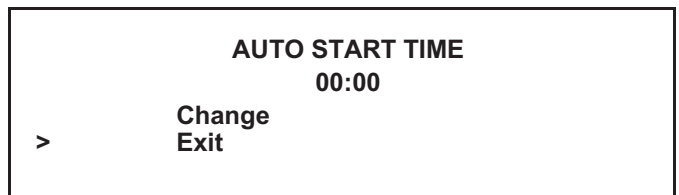

Program the AUTO START TIME by selecting the Up Arrow symbol to move the cursor to **Change**. Press the SEL symbol to advance to the next screen.

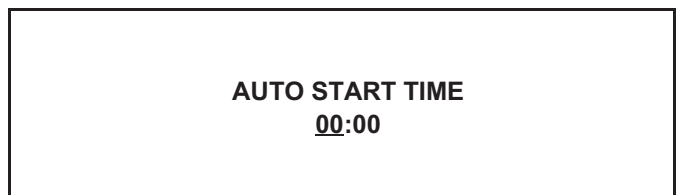

Use the arrow symbols to program the AUTO START TIME by increasing or decreasing the hour setting above the cursor. Press the SEL symbol to advance the cursor

and program the minutes setting. Select the SEL symbol to return to the previous screen with the new time setting displayed. Select the SEL symbol to exit the screen and return to the Manager's Menu.

The Standby option is used to manually place either side of the machine in the Standby mode during long, no draw periods. Select the Standby screen from the Manager's Menu. Press the SEL symbol to activate Standby.

Discontinue Standby operation by exiting the Manager's Menu and selecting the Auto mode.

```
STANDBY MODE
LEFT
RIGHT
> Exit
```

The MIX LEVEL AUDIBLE option, when enabled, will alert the operator with an audible tone when there is a mix low or mix out condition. The following screen is displayed upon selecting this option.

```
MIX LEVEL AUDIBLE
ENABLED
> Enable
Disable
```

Disable the audible tone feature by selecting the Down Arrow symbol to move the cursor to **Disable**. Select the SEL symbol to save the new setting and return to the Manager's Menu. The control panel icons for Mix Low and Mix Out will illuminate as the mix level drops in the hopper but the audible tone will be disabled.

The FAULT DESCRIPTION screen lists any faults detected by the control and allows the manager to clear them from the system. Faults are displayed on the second and/or third line.

```
FAULT DESCRIPTION
L: Beater Overload
R: Beater Overload
```

Pressing the SEL symbol displays the next fault or returns to the Manager's Menu if no other faults exist. Pressing the SEL symbol any time faults are displayed will clear corrected faults upon returning to the Manager's Menu. Press the Menu symbol  to return to the Manager's Menu.

The FAULT HISTORY screen displays a history of the last 100 faults. Page numbers are displayed in the upper right corner. Page 1 contains the most recent fault. Use the arrow symbols to cycle through the history pages. The date and time of the event are displayed on the second line. The third line displays the reason for the fault.

```
FAULT HISTORY 1
02/27/12 12:58
HPCO COMPRESSOR
> Exit
```

The LOCKOUT HISTORY screen displays a history of the last 100 hardlocks, brush-clean dates, etc.

```
LOCKOUT HISTORY
02/27/12 12:58
< HPR THERM FAIL
> Exit
```

Use the arrow symbols to advance forward or backward to view each screen. The following list indicates the variable messages that may appear. Press the SEL symbol to return to the Manager's Menu.

Note: If no fault was found, the message will state, **NO FAULT FOUND**.

Faults Occurring While in Auto or Standby Mode

BEATER OVERLOAD—Place the power switch in the OFF position. Wait 5 minutes for the machine to cool. Press the beater motors reset button firmly. Place the power switch in the ON position and restart in AUTO.

HPCO COMPRESSOR—Place the power switch in the OFF position. Wait 5 minutes for the machine to cool. Place the power switch in the ON position and restart in AUTO.

L/R HPR Therm Fail—The hopper thermistor failed. Call for service.

L/R BRL Therm Fail—The freezing cylinder thermistor failed. Call for service.

L/R HPR>59F (15C)—The mix temperature in the hopper exceeded 59°F (15°C).

L/R BRL>59F (15C)—The mix temperature in the freezing cylinder exceeded 59°F (15°C).

L/R HPR>45F (7C) AFTER 1 HR—The mix temperature in the hopper was above 45°F (7°C) for more than 1 hour.

L/R BRL>45F (7C) AFTER 1 HR—The mix temperature in the freezing cylinder was above 45°F (7°C) for more than 1 hour.

L/R HPR>41F (5C) AFTER 4 HR—The mix temperature in the hopper was above 41°F (5°C) for more than 4 hours.

L/R BRL>41F (5C) AFTER 4 HR—The mix temperature in the freezing cylinder was above 41°F (5°C) for more than 4 hours.

L/R HPR>41F (5C) AFTER PF—The mix temperature in the hopper was above 41°F (5°C) for more than 4 hours, following a power failure.

L/R BRL>41F (5C) AFTER PF—The mix temperature in the freezing cylinder was above 41°F (5°C) for more than 4 hours, following a power failure.

Note: Refer to your local health codes regarding temperature recommendations for procedures to follow if these fault screens appear.

The system information is displayed on three separate screens. The first screen contains the control and software version installed in the machine.

```

SOFTWARE VERSION
C722 CONTROL UVC4
VERSION V00.00.000
> Next
    
```

Press the SEL symbol to advance to the next system information screen containing the software language version.

```

Language
V4.00 English

> Next
    
```

Press the SEL symbol to advance to the third system information screen containing the model bill of material and machine serial number. Pressing the SEL symbol again will return to the Manager's Menu.

```

B.O.M. C700000000
S/N      K0000000

> Next
    
```

The CURRENT CONDITIONS screen displays the current viscosity, and the hopper and barrel temperatures. Press the SEL or MENU symbols to return to the Manager's Menu.

```

VISC          0.0    0.0
HOPPER        41.0   41.0
BARREL        41.0   41.0
    
```

The NET SERVICE PIN screens allows the manager to initialize a network connection for networking kitchens.

```

NET SERVICE PIN
ARE YOU SURE?
Yes
> No
    
```

Use the arrow symbols to move the cursor up or down. Pressing the SEL symbol with the arrow cursor next to **No** will return to the Manager's Menu. Pressing the SEL symbol with the arrow cursor next to **Yes** will connect to the network if a gateway card is connected.

Note: If **Yes** is selected, it may take a few moments for the memory to clear and the defaults to load. The display may show the message **COMMUNICATIONS FAILURE** during this time.

The Model C722 is a medium-capacity soft serve machine. Mix is stored in the hoppers. The machine is equipped with a three-spout door and two 2.8 qt. (2.7 L) capacity freezing cylinders.

We begin our instructions at the point where we enter the store in the morning and find the parts disassembled and laid out to air dry from the previous night's cleaning.

These opening procedures will show you how to assemble the parts into the freezer, sanitize them, and prime the freezer with **fresh** mix in preparation to serve your first portion.

If you are disassembling the machine for the first time or need information to get to this starting point in our instructions, turn to "Disassembly" on page 6-11, and start there.

Assembly

Note: When lubricating parts, use an approved food-grade lubricant (example: Taylor Lube).



WARNING! Make sure the control switch is in the OFF position to eliminate the chance of moving parts. Failure to follow this instruction may result in severe personal injury from hazardous moving parts.

1. Lubricate the groove on the beater driveshaft.
2. Slide the beater driveshaft boot seal over the small end of the beater driveshaft and engage into the groove on the shaft.
3. Heavily lubricate the inside portion of the boot seal. Also lubricate the flat end of the boot seal that comes in contact with the rear shell bearing.
4. Apply an even coat of lubricant to the shaft. **Do not lubricate the hex end.**

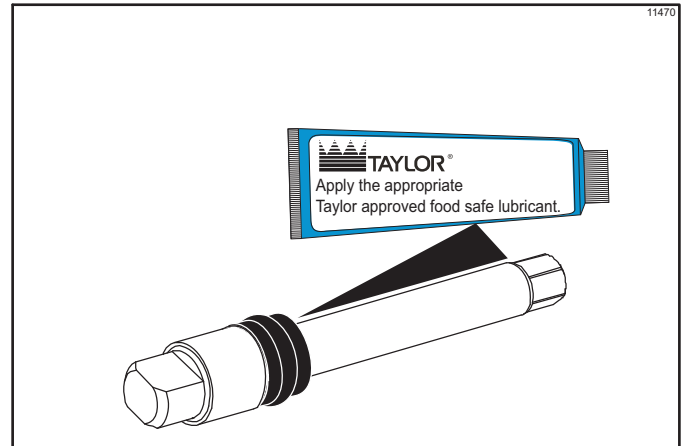

Figure 6-1

Note: To ensure that mix does not leak out of the back of the freezing cylinder, the middle section of the boot seal should be convex or extend out from the seal. If the middle section of the boot seal is concave or extending into the middle of the seal, turn the seal inside out.

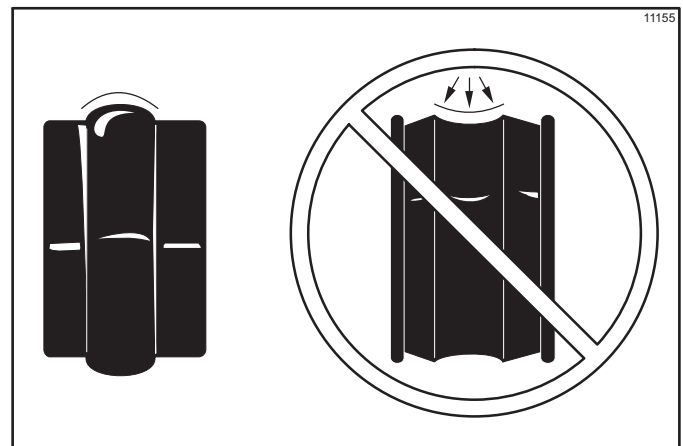

Figure 6-2

5. Insert the beater driveshaft through the rear shell bearing in the freezing cylinder and engage the hex end firmly into the drive coupling.

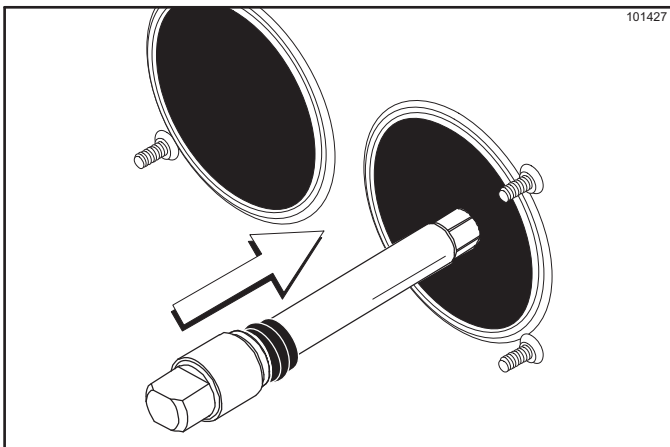

Figure 6-3



WARNING! Use extreme caution when handling the beater assembly. The scraper blades are very sharp and may cause injury.

6. Before installing the beater assembly, check the scraper blades.

Check the scraper blades for any signs of wear or damage. If a scraper blade is nicked or worn, replace both blades.

6

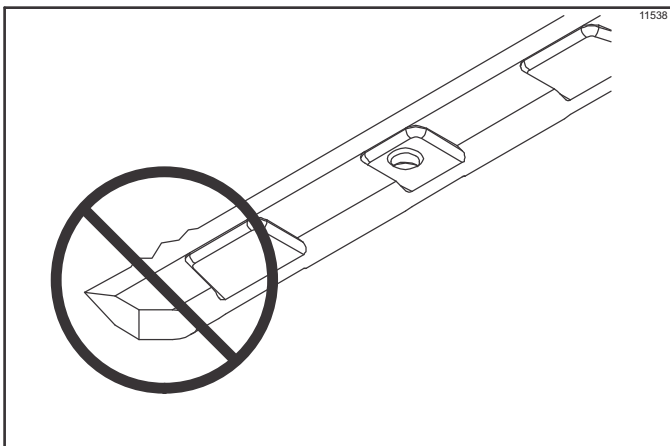

Figure 6-4

If the blades are in good condition, place the rear scraper blade over the rear holding pin on the beater.

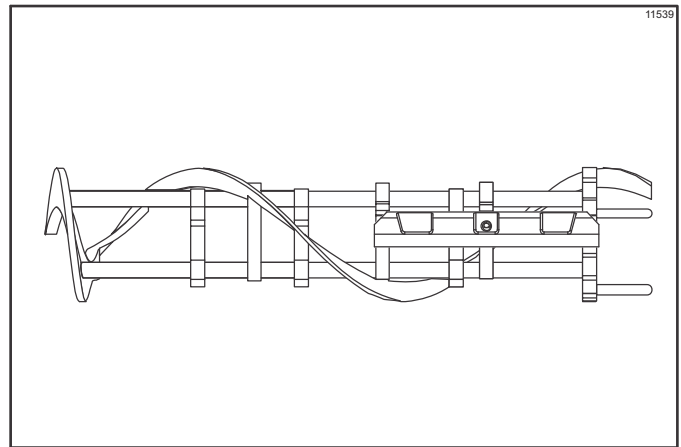

Figure 6-5

Note: *Scraper blades should be replaced every 3 months.*

Note: *The hole on the scraper blade must fit securely over the pin to prevent damage.*

7. Holding the rear blade on the beater, slide it halfway into the freezing cylinder. Install the front scraper blade over the front holding pin.

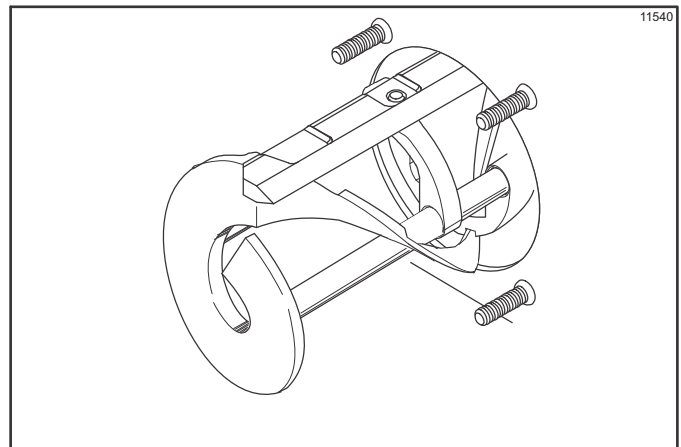

Figure 6-6

8. Before installing the beater shoes, check the shoes for any nicks, cracks, or signs of wear. If any defects are present, replace the beater shoes.
9. If the beater shoes are in good condition, install the beater shoes.

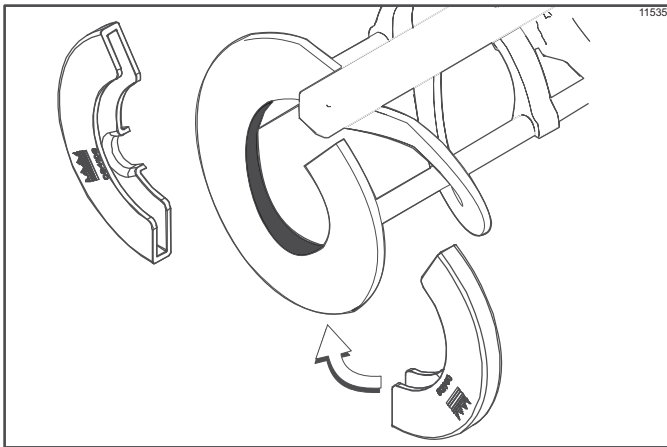

Figure 6-7

10. Slide the beater assembly the rest of the way into the freezing cylinder. Make sure the beater assembly is in position over the driveshaft by turning the beater slightly until the beater is properly seated. When in position, the beater will not protrude beyond the front of the freezing cylinder.

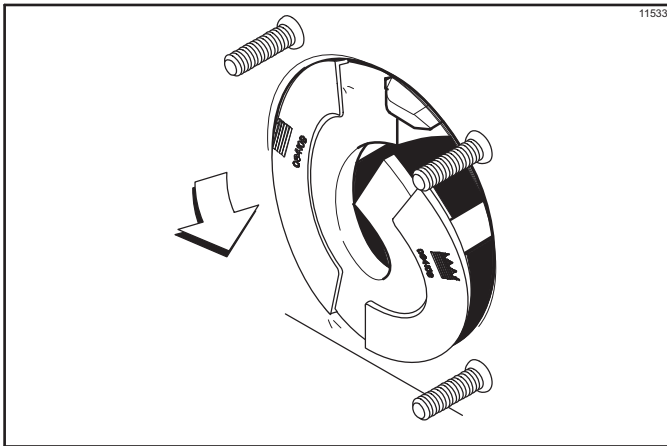

Figure 6-8

11. Repeat steps 1 through 10 for the other side of the machine.
12. Before assembling the freezer door, check the following for any nicks, cracks, or signs of wear: the door bearings, door gaskets, draw valves, O-rings, and all sides of the door assembly, including the inside of the draw valve bores. Replace any damaged parts.
13. Place the door gaskets into the grooves on the back of the freezer door. Do not lubricate the gaskets.

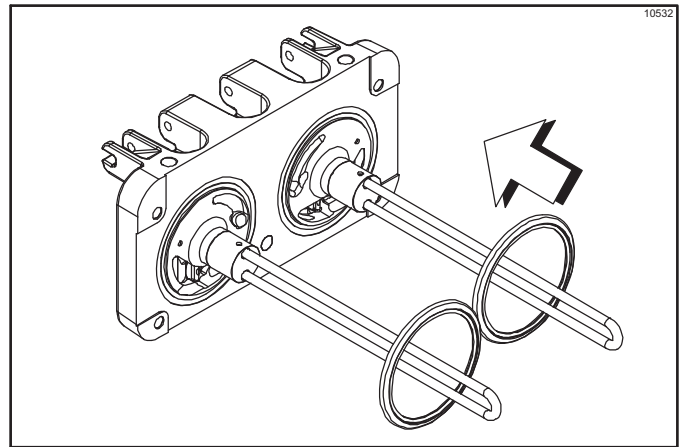
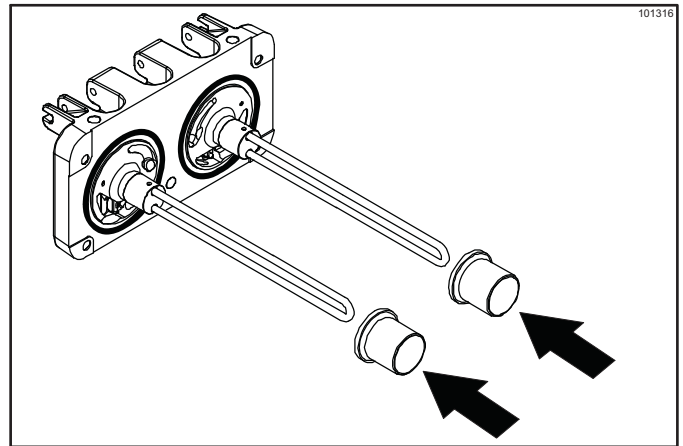

Figure 6-9

14. Slide the front bearings over the baffle rods. The flanged edges should be against the door. **Do not lubricate the gaskets or front bearings.**



- Slide the two O-rings into the grooves on each prime plug. Apply an even coat of Taylor Lube to the O-rings and shafts.

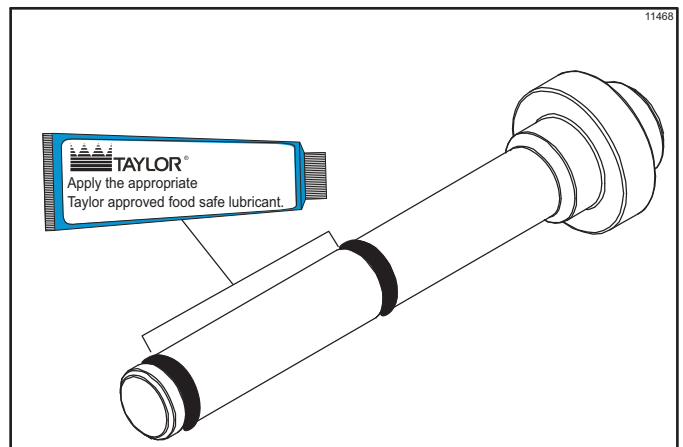

Figure 6-10

OPERATING PROCEDURES

15. Insert the prime plugs into the holes in the top of the freezer door, and push down.

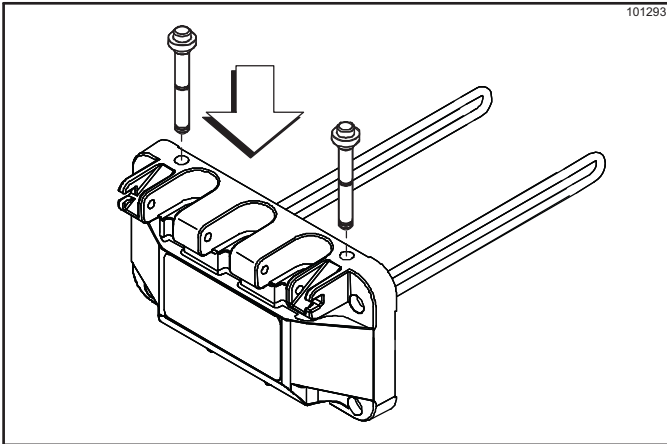

Figure 6-11

16. To install the freezer door, insert the baffle rods through the beaters in the freezing cylinders.

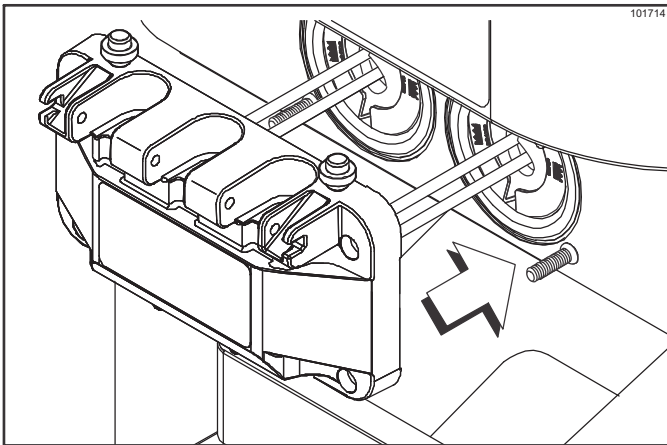

Figure 6-12

With the door seated on the freezer studs, install the handscrews. Use the long handscrews on the top and the short handscrews on the bottom. Tighten them equally in a crisscross pattern to ensure the door is secured.

17. Slide the three O-rings into the grooves of each standard draw valve. Slide the H-ring and O-ring into the grooves of the center draw valve. Lubricate the H-ring and O-rings.

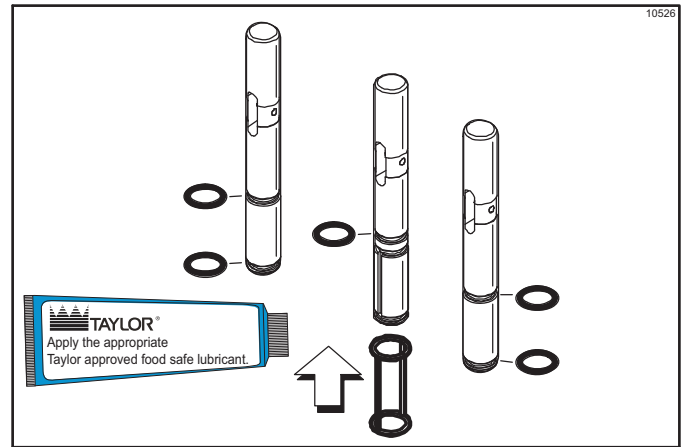

Figure 6-13

18. Lubricate the inside of the freezer door spouts, top and bottom.

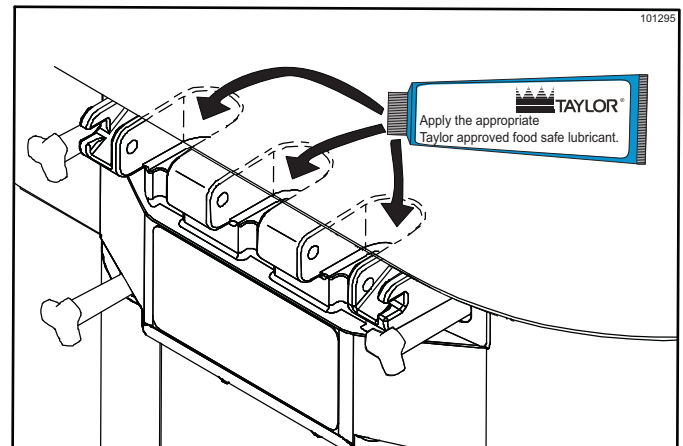

Figure 6-14

19. Insert the draw valves from the bottom until the slot in each draw valve comes into view.

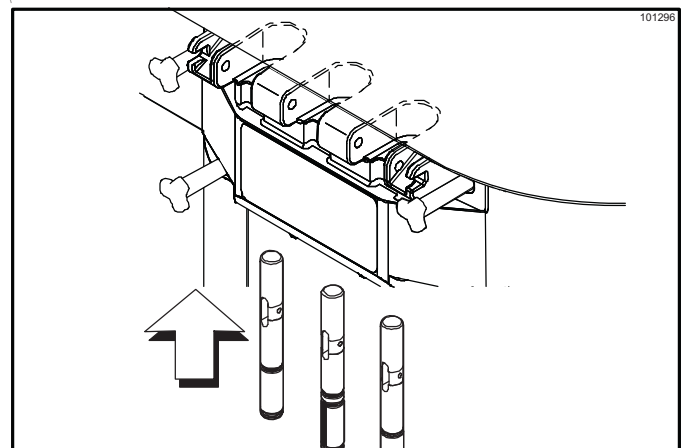

Figure 6-15

20. Position each draw handle with the adjustment screw facing down. Slide the fork of each draw handle into the slot of each draw valve, starting from the right.

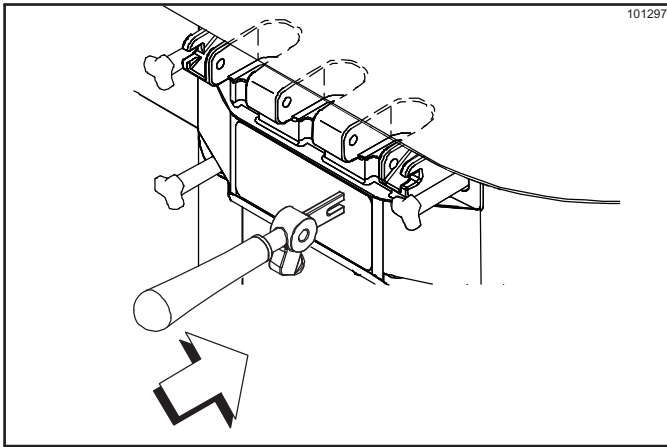

Figure 6-16

21. Slide the pivot pin through the draw handles as the handles are inserted into the draw valves.

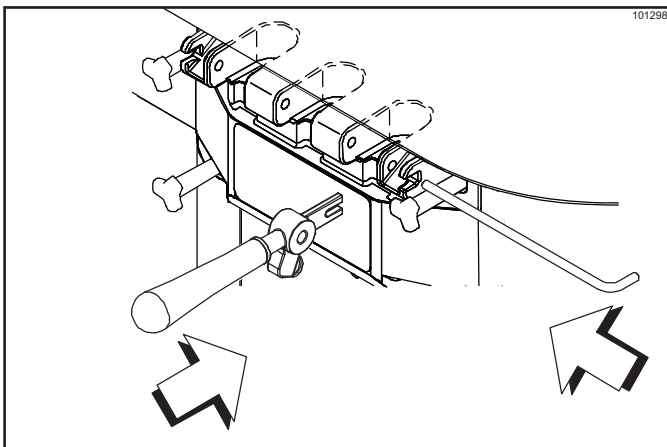

Figure 6-17

Note: This freezer features three adjustable draw handles to provide portion control, giving a better consistent quality to your product and controlling costs. The draw handle should be adjusted to provide a flow rate of 5 oz. to 7-1/2 oz. (148 ml to 222 ml) of product by weight per 10 seconds.

To **increase** the flow rate, tighten the screw. To **decrease** the flow rate, loosen the screw.

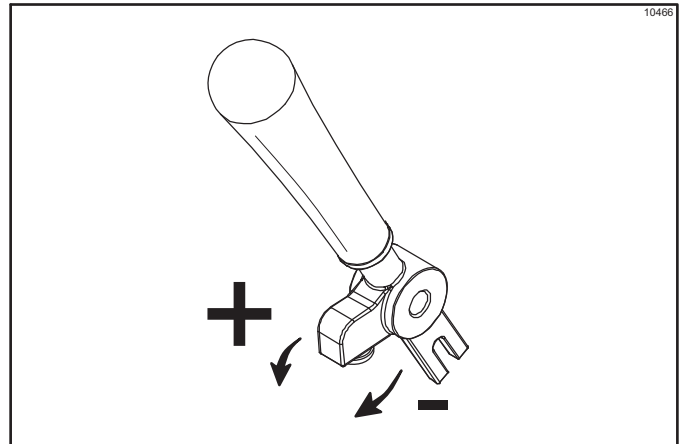

Figure 6-18

22. Snap the design caps over the bottom of the door spouts.

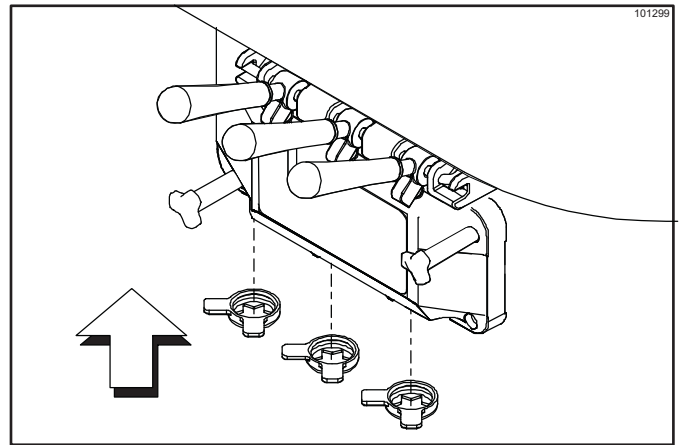

Figure 6-19

23. Slide the drip pan into the hole in the front panel.

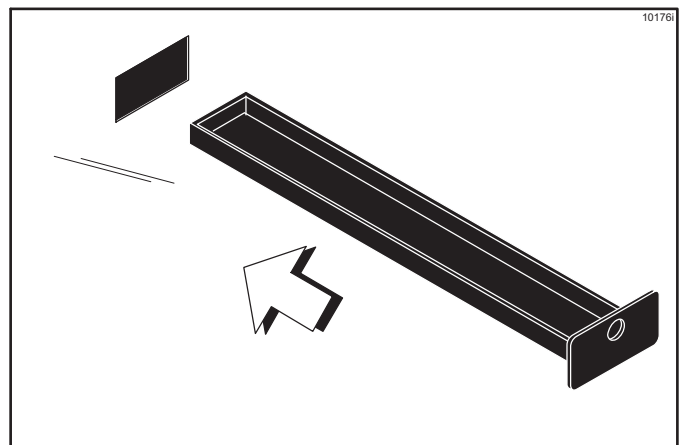

Figure 6-20

OPERATING PROCEDURES

24. Install the front drip tray and splash shield under the door spouts.

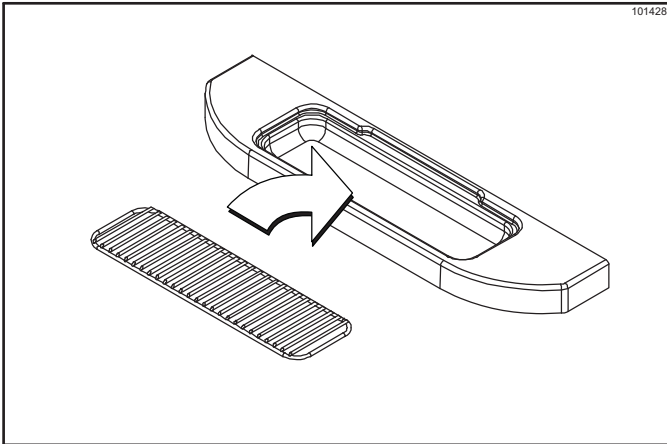

Figure 6-21

3. Apply a thin layer of lubricant to the inside of the pump cylinder at the retaining pin hole end.

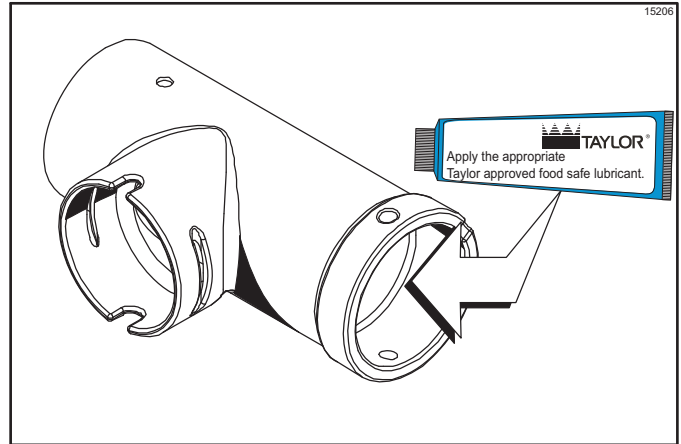

Figure 6-23

Mix Pump Assembly

1. Inspect the rubber pump parts. The O-rings and gasket must be in 100% good condition for the pump and the machine to operate properly. The O-rings and gasket cannot properly serve their intended function if nicks, cuts, or holes in the material are present.

Inspect the plastic pump parts for cracks, wear, and delamination of the plastic.

Replace any defective parts immediately.

2. Assemble the piston. Slide the red O-ring into the groove of the piston. **Do not** lubricate the O-ring.

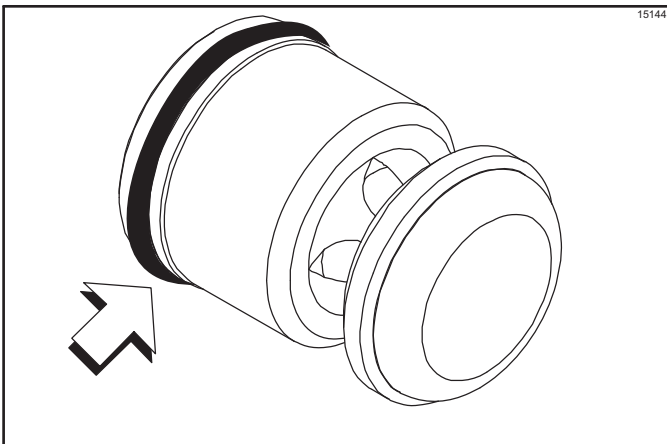

Figure 6-22

4. Insert the piston into the retaining pin hole end of the pump cylinder.

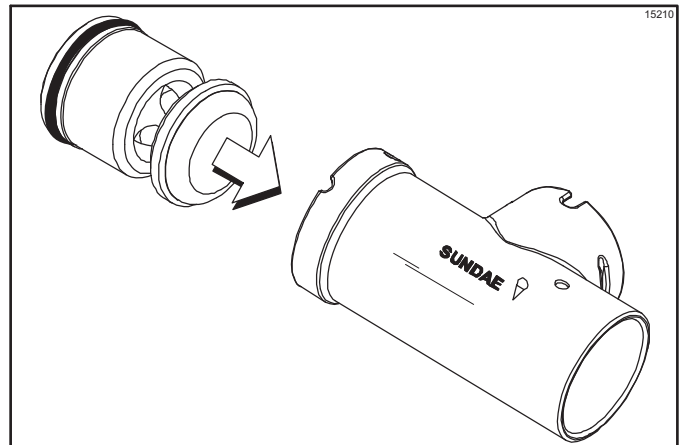

Figure 6-24

5. Assemble the valve cap. Slide the O-ring into the groove of the valve cap. **Do not** lubricate the O-ring.

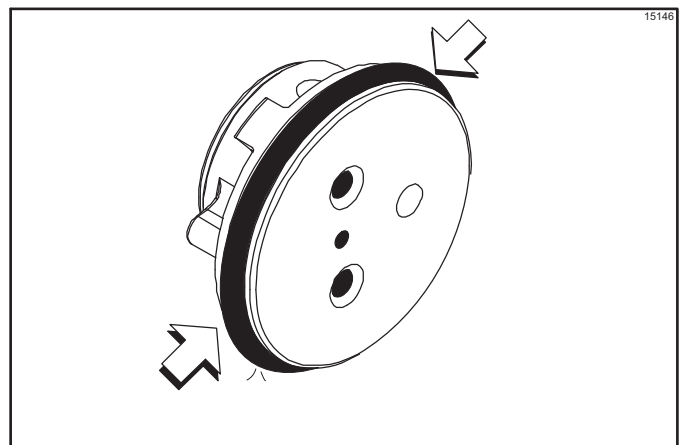

Figure 6-25

- Slide the pump valve gasket into the holes on the cap. **Do not** lubricate the gasket.

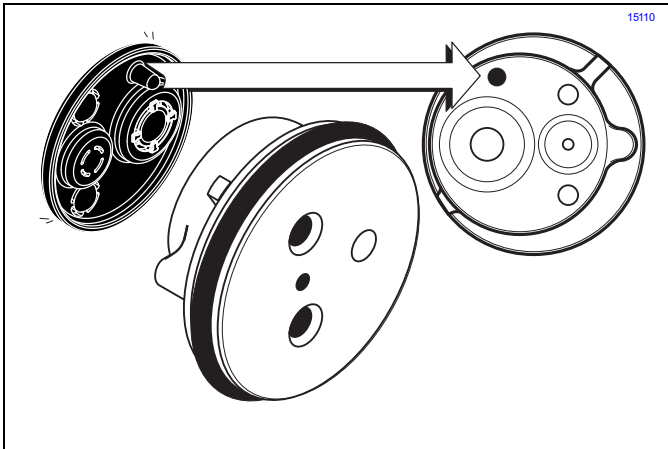

Figure 6-26

- Insert the valve body cap into the hole in the mix inlet adapter.

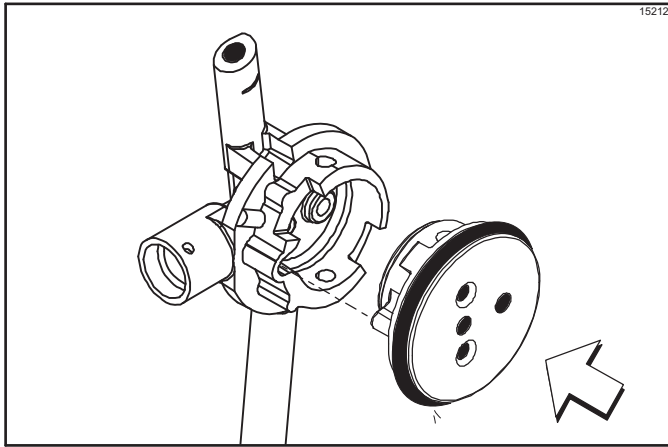

Figure 6-27

- Insert the mix inlet assembly into the pump cylinder.

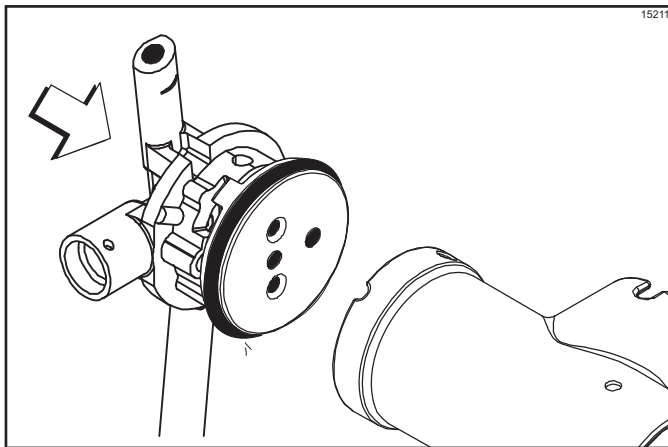

Figure 6-28

The adapter must be positioned into the notch located at the end of the pump cylinder.

- Secure the pump parts in position by sliding the

retaining pin through the cross holes located at one end of the pump cylinder.

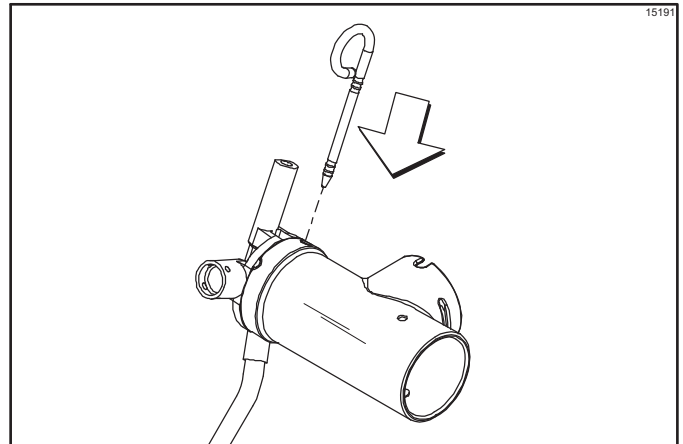

Figure 6-29

Note: The head of the retaining pin should be located at the top of the pump when installed.

- Assemble the feed tube assembly. Slide the check ring into the groove of the feed tube.

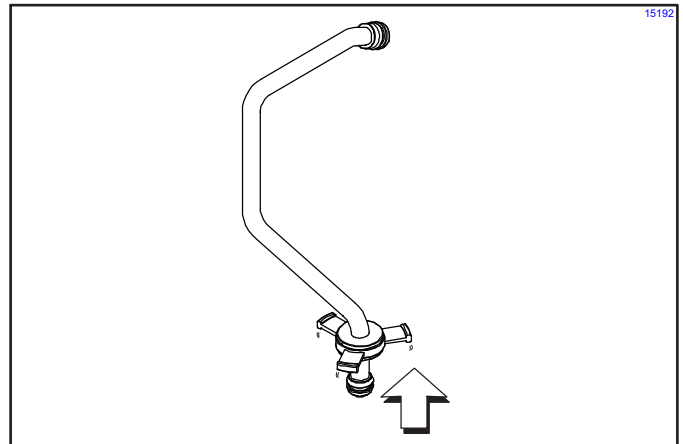

Figure 6-30

- Install one red O-ring on each end of the mix feed tube, and thoroughly lubricate it.

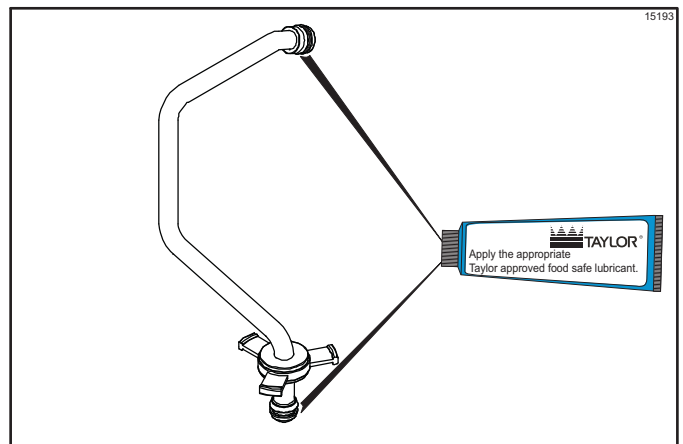

Figure 6-31

OPERATING PROCEDURES

12. Lay the pump assembly, pump clip, cotter pin, mix feed tube, and the agitator in the bottom of the mix hopper for sanitizing.
13. Slide the large black O-ring and the two smaller black O-rings into the grooves on the driveshaft. Thoroughly lubricate the O-rings and shaft. **Do not** lubricate the hex end of the shaft.

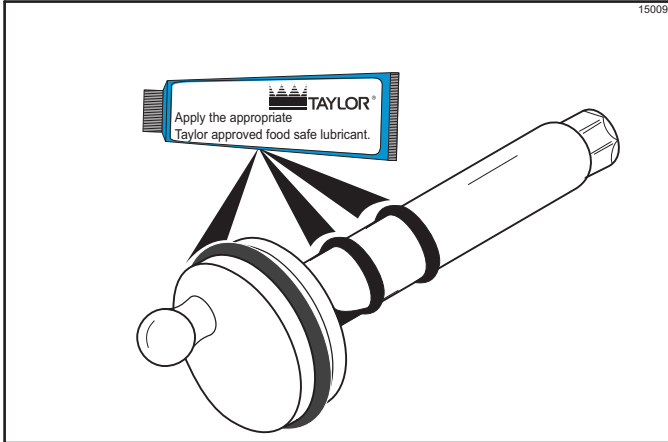

Figure 6-32

14. Install the hex end of the driveshaft into the drive hub at the rear wall of the mix hopper.

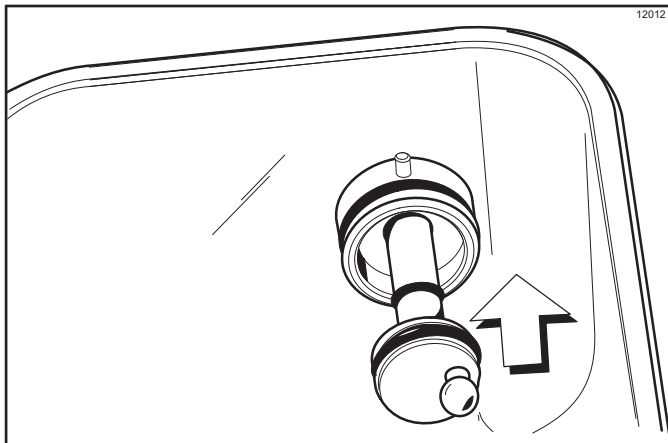

Figure 6-33

Note: For ease in installing the pump, position the ball crank of the driveshaft in the three o'clock position.

Repeat steps 1 through 14 for the other side of the machine.

Sanitizing

1. Prepare a pail of cleaning/sanitizing solution with an active chlorine concentrate of 100 ppm–200 ppm (parts per million).

Important! Use warm water and follow the manufacturer's specifications.

2. Pour sanitizing solution over all the parts in the bottom of the mix hopper and allow it to flow into the freezing cylinder.

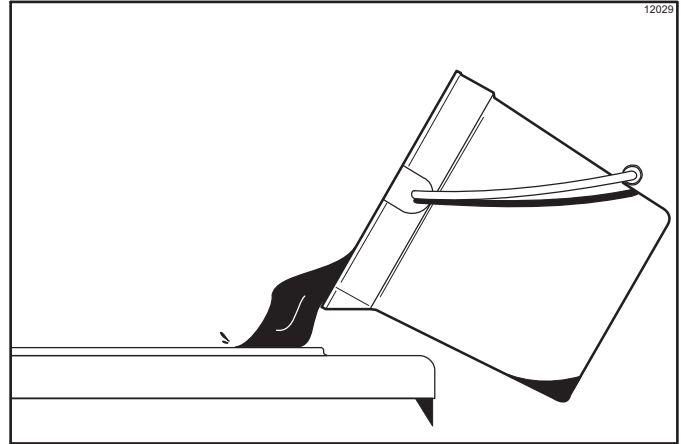

Figure 6-34

Note: You have just sanitized the mix hopper and parts. Therefore, make sure your hands are clean and sanitized before proceeding with these instructions.

3. While the solution is flowing into the freezing cylinder, take particular care to brush-clean the mix-level sensing probe, mix hopper, mix inlet hole, air/mix pump, pump clip, mix feed tube, cotter pin, and agitator.
4. Install the pump assembly at the rear of the mix hopper. To position the pump on the drive hub, align the drive hole in the piston with the drive crank of the driveshaft. Secure the pump in place by slipping the pump clip over the collar of the pump, making sure the clip fits into the grooves in the collar. (See Figure 6-35.)

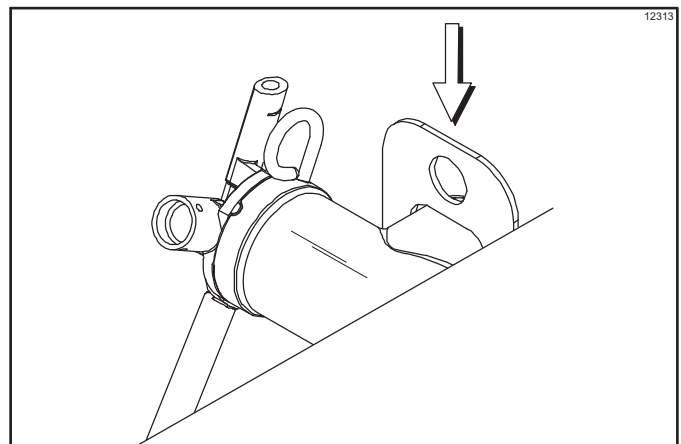

Figure 6-35

- Important:** Install the pump end of the mix feed tube and secure it with the cotter pin. Failure to follow this instruction could result in sanitizer spraying on the operator. (See Figure 6-36.)

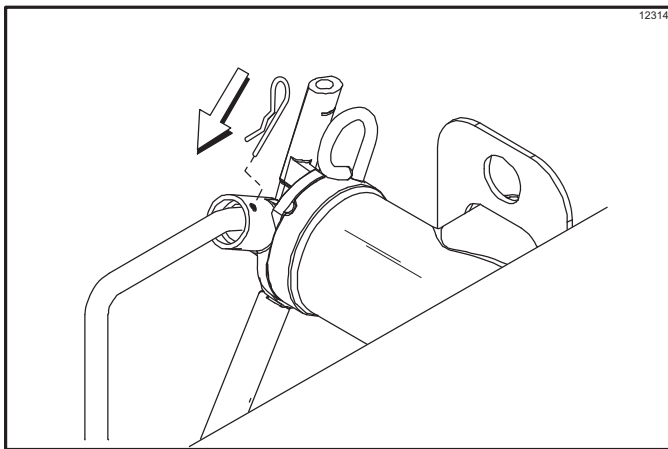





Figure 6-36

- Prepare another pail of cleaning/sanitizing solution with an active chlorine concentrate of 100 ppm–200 ppm.

Important! Use warm water and follow the manufacturer's specifications.

- Pour the sanitizing solution into the mix hopper.
- Brush the exposed sides of the hopper.
- Place the power switch in the ON position.
- Press the Wash symbol . This will cause the sanitizing solution in the freezing cylinder to be agitated. Wait at least 5 minutes before proceeding with these instructions.
- With an empty pail beneath the door spouts, raise the prime plug and press the Mix Pump  symbol.
- When a steady stream of sanitizing solution is flowing from the prime plug opening in the bottom of the freezer door, open the draw valve. Momentarily open the center draw valve to sanitize the center door spout. Draw off the remaining sanitizing solution.
- Once the sanitizer stops flowing from the door spout, press the Wash  and Mix Pump  symbols and close the draw valve.

Important! The machine **must not be placed in Auto until all sanitizing solution has been removed** from the freezing cylinder and proper priming procedures have been completed. Failure to follow this instruction may result in damage to the freezing cylinder.

Note: Make sure your hands are clean and sanitized before proceeding with these instructions.

- Place the agitator on the agitator driveshaft housing.

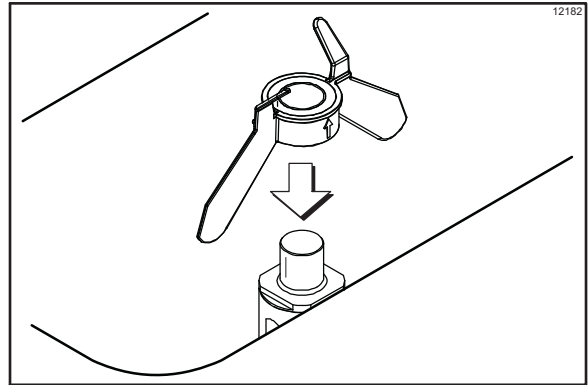

Figure 6-37

Note: If the agitator should stop turning during normal operation, with **sanitized hands**, remove the agitator from the agitator driveshaft housing and brush-clean it with sanitizing solution. Install the agitator back onto the agitator driveshaft housing.

Repeat steps 1 through 14 for the other side of the machine.

Priming

Note: Use only **fresh** mix when priming the freezer.

- Place an empty pail beneath the door spouts. With the prime plug in the **up** position, pour 2-1/2 gal. (9.5 L) of **fresh** mix into the mix hopper and allow it to flow into the freezing cylinder.
- Open the draw valve to remove the sanitizing solution. When only **fresh** mix is flowing, close the draw valve.

OPERATING PROCEDURES

- Once a steady stream of mix starts to flow from the prime plug opening in the bottom of the freezer door, push the prime plug down.

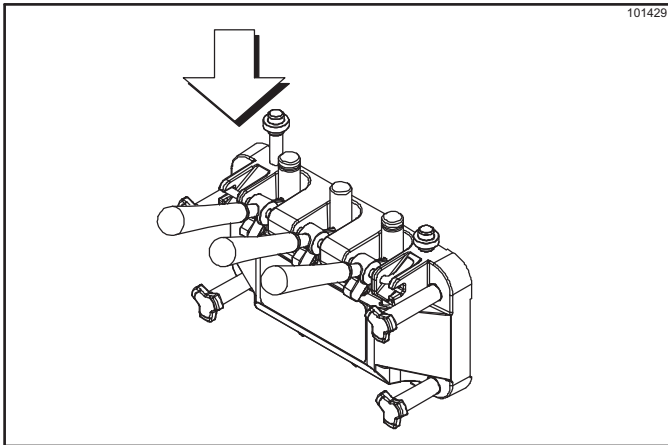

Figure 6-38

Important! Failure to remove all sanitizing solution may result in damage to the freezing cylinder.

- When mix stops bubbling down into the freezing cylinder, remove the cotter pin from the outlet fitting of the mix pump. Insert the outlet end of the mix feed tube into the mix inlet hole in the mix hopper. Place the inlet end of the mix feed tube into the outlet fitting of the mix pump. Secure it with the cotter pin.

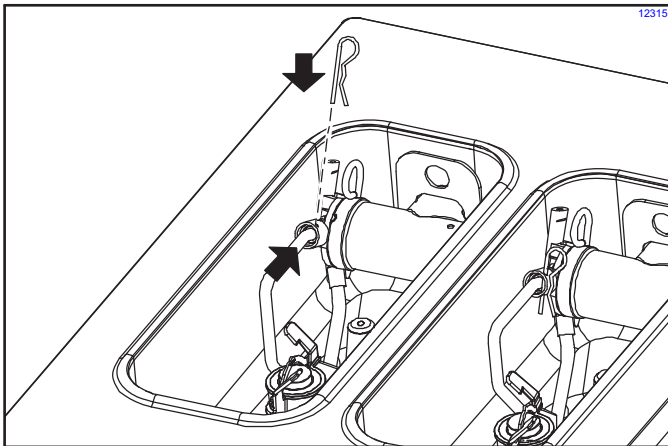

Figure 6-39

- Select the Auto symbol

Note: The brush-clean counter will start at this time.

- Fill the hopper with **fresh** mix and place the mix hopper cover in position.

Repeat steps 1 through 6 for the other side of the machine.

Closing Procedure

Note: These procedures must be completed every day.



ALWAYS FOLLOW LOCAL HEALTH CODES.

To disassemble the Model C722, the following items will be needed.

- Two cleaning and sanitizing pails
- Sanitizer/cleaner
- Cleaning brushes (provided with the machine)
- Single-service towels

Draining Product from the Freezing Cylinder

- With a pail beneath the door spouts, open the draw valve. Press the Wash and Mix Pump symbols.

Important! Do not allow the pump to keep running when the draw valve is closed. Excessive pressure will build up causing product to spurt out when the draw valve is opened.

Drain the product from the freezing cylinder and the mix hopper.

- When the flow of product stops, press the Wash and Pump symbols, canceling the Wash and Pump modes. Close the draw valve.
- Remove the agitator, cotter pin, mix feed tube, pump clip, and assembled air/mix pump.

Repeat steps 1 through 3 for the other side of the machine.

Rinsing

- Pour 2 gal. (7.6 L) of cool, clean water into the mix hopper. With the hopper brush, scrub the mix hopper, mix-level sensing probe, and the outside of the agitator driveshaft housing (factory-equipped agitator machines only). Using the double-ended brush, clean the mix inlet hole. (See Figure 6-40.)

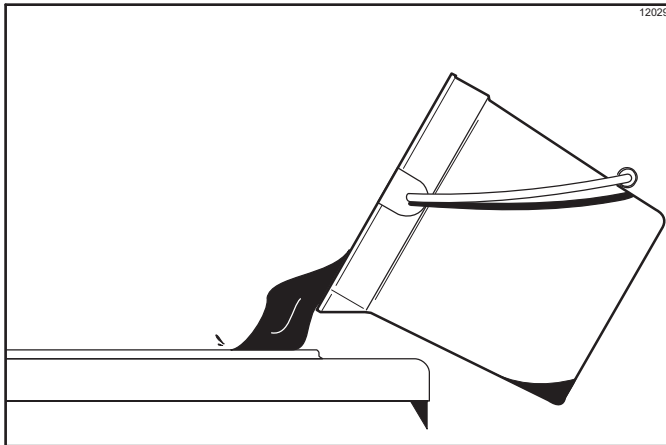



Figure 6-40

Note: Do not brush-clean the mix inlet hole while the machine is in the Wash mode.



2. With a pail beneath the door spout, raise the prime plug and press the Wash symbol .
3. When a steady stream of rinse water is flowing from the prime plug opening in the bottom of the freezer door, open the draw valve. Drain all the rinse water from the door spout. Close the draw valve and push the prime plug down.
4. Press the Wash symbol , canceling the Wash mode.
5. Repeat steps 1 through 4 using clean, warm water, until the water being discharged is clear.

Repeat steps 1 through 5 for the other side of the machine.

Hopper Cleaning

1. Prepare a pail of cleaning/sanitizing solution with an active chlorine concentrate of 100 ppm–200 ppm.
Important! Use warm water and follow the manufacturer's specifications.
2. With the prime plug pushed down, pour the cleaning solution into the hopper. Allow the solution to flow into the freezing cylinder.
3. Using the hopper brush, clean the mix hopper, mix-level sensing probes, and the outside of the agitator driveshaft housing. Using the double-ended brush, clean the mix inlet hole.

Note: Do not brush-clean the mix inlet hole while the machine is in the Wash mode.

4. Press the Wash symbol . This will cause the cleaning solution in the freezing cylinder to come in contact with all areas of the freezing cylinder. Wait at least 5 minutes before proceeding with these instructions.
5. Place an empty pail beneath the door spouts.
6. Raise the prime plug.
7. When a steady stream of cleaning solution is flowing from the prime plug opening in the bottom of the freezer door, open the draw valve. Draw off all the solution.
8. Once the cleaning solution stops flowing from the door spout, close the draw valve and the prime plug.
9. Press the Wash symbol , cancelling the Wash mode.

Repeat steps 1 through 9 on the other side of the machine.

Disassembly



WARNING! Make sure the control switch is in the OFF position to eliminate the chance of moving parts. Failure to follow this instruction may result in severe personal injury from hazardous moving parts.

1. Remove the handscrews, freezer door, beaters, scraper blades, and driveshafts with the driveshaft seals from the freezing cylinders.
2. Remove the driveshaft seal from each driveshaft.
3. From each pump cylinder, remove the retaining pin, mix inlet adaptor, valve cap, pump gasket, and the piston. Remove the O-ring from the piston and valve cap.
4. Remove the freezer door gaskets, front bearings, pivot pin, draw handles, draw valves, prime plugs, and design caps. Remove the O-rings from the draw valves.

OPERATING PROCEDURES

5. Remove the pump driveshafts from the drive hubs in the rear wall of the mix hoppers. (See Figure 6-41.)

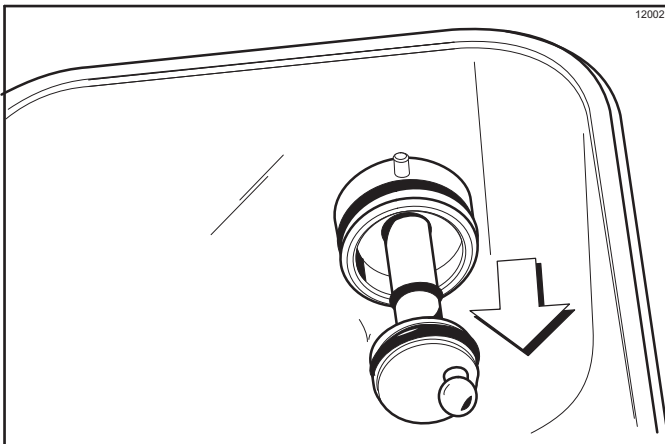

Figure 6-41

6. Remove the two small O-rings and one large O-ring from each pump driveshaft.
7. Remove the front drip tray and splash shield.
8. Remove all drip pans. Take all parts removed in steps 1 through 8 to the sink for cleaning. (See Figure 6-42.)

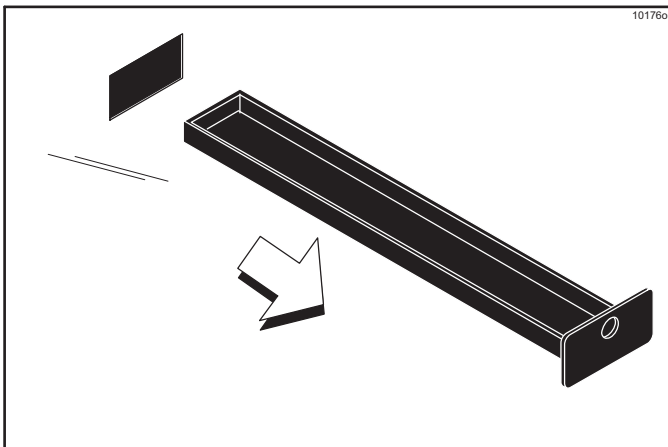

Figure 6-42

Note: If the drip pans are filled with an excessive amount of mix, the driveshaft seal(s) or O-ring(s) should be replaced or properly lubricated.

Manual Brush-Cleaning

These procedures must be completed according to the frequency specified by your federal, state, or local regulatory agencies. Please consult your governing Food Code to determine the maximum number of days allowed between brush-clean cycles.

Use the recommended cleaning procedure outlined in the manual or an alternate procedure used in conjunction with a cleaning/sanitizing system that has been certified by NSF.



ALWAYS FOLLOW LOCAL HEALTH CODES.

1. Prepare a sink with cleaning/sanitizing solution with an active chlorine concentrate of 100 ppm to 200 ppm.
Important! Use warm water and follow the manufacturer's specifications.
Make sure all brushes provided with the freezer are available for cleaning.
2. Thoroughly brush-clean all disassembled parts in the cleaning solution, making sure all lubricant and mix film is removed. Make sure to brush all surfaces and holes, especially the holes in the pump components and the draw valve holes in the freezer door.
Rinse all parts with clean, warm water. Place the parts on a clean, dry surface to air dry overnight.
3. Return to the freezer with a small amount of cleaning solution. Using the black brush, clean the rear shell bearing at back of each freezing cylinder. (See Figure 6-43.)

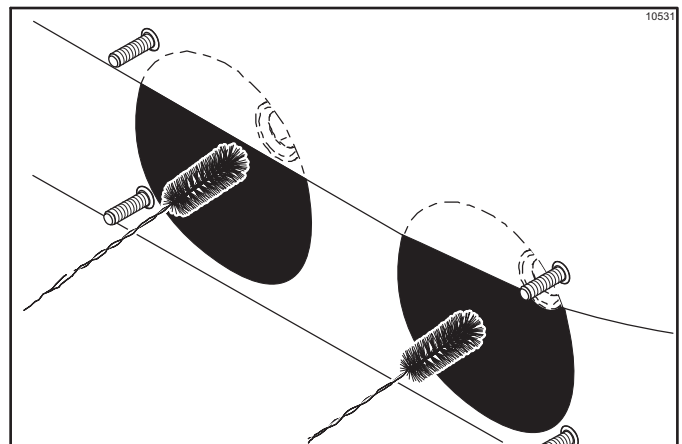

Figure 6-43

- Using the black brush, clean the drive hub opening in the rear wall of each mix hopper. (See Figure 6-44.)

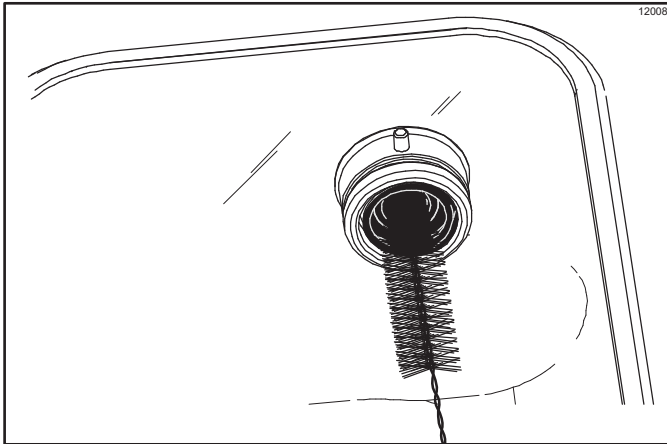

Figure 6-44

- Wipe all exterior surfaces of the freezer with a clean, sanitized towel.

Note: *The brush-clean counter will reset to zero at this time.*

During Cleaning and Sanitizing



ALWAYS FOLLOW LOCAL HEALTH CODES.

Cleaning and sanitizing schedules are governed by federal, state, or local regulatory agencies, and must be followed accordingly. If the machine has a Standby mode, it must not be used instead of proper cleaning and sanitizing procedures and frequencies set forth by the ruling health authority. The following check points should be stressed during the cleaning and sanitizing operations.



IMPORTANT! *Cleaning and sanitizing must be performed daily.*

Troubleshooting Bacterial Count

- Thoroughly clean and sanitize the machine regularly, including complete disassembly and brush-cleaning.
- Use all brushes supplied for thorough cleaning. The brushes are specially designed to reach all mix passageways.
- Use the bristle brush to clean the mix inlet hole which extends from the mix hopper down to the rear of the freezing cylinder.
- Use the black bristle brush to thoroughly clean the rear shell bearing located at the rear of the freezing cylinder and the drive hub opening in the rear wall of the mix hopper. Use a generous amount of cleaning solution on the brush.
- Properly prepare the cleaning and sanitizing solutions. Read and follow the label directions carefully. Too **strong** of a solution may damage the parts, and too **weak** of a solution will not do an adequate job of cleaning or sanitizing.
- The temperature of the mix in the mix hopper and walk-in cooler should be below 40°F (4.4°C).

- Discard the remaining mix from the freezer during the cleaning procedures.

Regular Maintenance Checks

- Replace scraper blades that are nicked or damaged. Before installing the beater assembly, make sure the scraper blades are properly attached to the helix.
- Check the rear shell bearing for signs of wear (excessive mix leakage in rear drip pan) and make sure it is properly cleaned.
- Using a screwdriver and cloth towel, clean the rear shell bearing and the female hex drive socket of lubricant and mix deposits.
- Dispose of O-rings and seals if they are worn, torn, or fit too loosely, and replace them with new ones.
- Follow all lubricating procedures as outlined in "Assembly."



CAUTION! *Always disconnect the electrical power prior to cleaning the condenser. Failure to follow this instruction may result in electrocution.*

- If your machine is air-cooled, check the condenser for dirt and lint accumulation. Dirty condensers will reduce the efficiency and capacity of the machine. Condensers should be cleaned **monthly** with a soft brush. **Never** use screwdrivers or other metal probes to clean between the fins.

Note: *For machines equipped with an air filter, it will be necessary to vacuum-clean the filters monthly.*

- If your machine is water-cooled, check the water lines for kinks or leaks. Kinks can occur when the machine is moved back and forth for cleaning or maintenance. Deteriorated or cracked water lines should be replaced only by an authorized Taylor distributor.

Winter Storage

If the place of business is to be closed during the winter months, it is important to protect the freezer by following certain precautions, particularly if the building is subject to freezing conditions.

Disconnect the freezer from the main power source to prevent possible electrical damage.

On water-cooled freezers, disconnect the water supply. Relieve pressure on the spring in the water valve. Use air pressure on the outlet side to blow out any water remaining in the condenser. **This is extremely important.** Failure to follow this procedure may cause severe and costly damage to the refrigeration system.

Your local Taylor distributor can perform this winter storage service for you.

Wrap detachable parts of the freezer (such as the beater, blades, driveshaft, and freezer door) and place them in a protected dry place. Rubber trim parts and gaskets can be protected by wrapping them with moisture-proof paper. All parts should be thoroughly cleaned of dried mix or lubrication, which can attract mice and other vermin.

It is recommended that a service technician perform winter storage draining to ensure all water has been removed. This will guard against freezing and rupturing of the components.

Table 8-1

Problem	Probable Cause	Remedy	Page Ref.
1. No product is being dispensed.	a. The mix out light is on—low on mix.	a. Add mix to mix hopper. Return to Auto mode.	6-9
	b. Power switch is in the OFF position.	b. Turn power switch to ON position and select Auto.	6-9
	c. Machine not in Auto mode.	c. Select AUTO and allow machine to cycle off before drawing product.	6-9
	d. Beater motor is out on reset. The BEATER OVERLOAD message displayed.	d. Turn machine off. Press the reset button. Restart the machine in Auto.	5-8
	e. Pump motor control is out on internal overload.	e. Turn power switch off. Remove and clean mix pump. Allow at least 2 minutes for power switch to remain off for control to reset. Once power is restored, before installing pump, press Pump key and verify the pump shaft rotates counterclockwise. Note: If this does not correct the problem or if rotation is clockwise, call a service technician.	---
	f. Feed tube or check ring not properly installed.	f. Make sure feed tube and rubber check ring are properly installed.	6-7, 6-9
	g. Butterfat buildup in the pump.	g. Carefully remove the mix pump. Clean and reinstall.	6-11
	h. Freeze-up in mix inlet hole.	h. Call a service technician.	---
	i. The mix pump ball crank is broken.	i. Call a service technician.	---
2. No control panel functions (power switch is on).	a. Machine is unplugged.	a. Plug into wall receptacle.	---
	b. Circuit breaker OFF or blown fuse.	b. Turn the breaker ON or replace the fuse.	---
3. The product is too soft.	a. Draw rate is set too fast.	a. Adjust draw rate: 5 oz. to 7-1/2 oz. (142 g to 213 g) of product by weight in 10 seconds.	6-5

TROUBLESHOOTING GUIDE

Problem	Probable Cause	Remedy	Page Ref.
4. The product is too thick.	a. Freezing cylinder not primed correctly.	a. Drain the freezing cylinder and reprime the machine.	6-9
	b. Air/mix pump incorrectly assembled.	b. Assemble and lubricate according to instructions in this manual.	6-6
	c. The viscosity control is set too cold.	c. Call a service technician.	---
	d. Freeze-up in mix inlet hole.	d. Call a service technician.	---
5. The mix in the hopper is too warm.	a. Hopper cover is not in position.	a. Clean and sanitize hopper cover and place in position.	6-9
	b. Agitator is not installed.	b. Clean, sanitize, and install the agitator.	6-9
	c. The hopper temperature is out of adjustment.	c. Call a service technician.	---
6. The mix in the hopper is too cold.	a. The hopper temperature is out of adjustment.	a. Call a service technician.	---
7. Mix low and mix out probes are not functioning.	a. Milkstone buildup in the hopper.	a. Clean hoppers thoroughly.	6-12
8. The mix pump will not operate.	a. Pump motor control is out on internal overload.	a. Turn power switch off. Remove and clean mix pump. Allow at least 2 minutes for power switch to remain off for control to reset. Once power is restored, before installing pump, press Pump key and verify pump shaft rotates counterclockwise. <i>Note: If rotation is clockwise, call a service technician.</i>	---
9. Product is collecting on top of the freezer door.	a. The top O-ring on draw valve is improperly lubricated or is worn.	a. Lubricate properly or replace the O-ring.	6-4
10. Excessive mix leakage from the bottom of door spout.	a. Bottom O-ring on draw valve is improperly lubricated or is worn.	a. Lubricate properly or replace the O-ring.	6-4
11. Excessive mix leakage into the drip pan.	a. The seal on driveshaft is improperly lubricated or is worn.	a. Lubricate properly or replace the seal.	6-1
	b. The seal is installed inside-out on the driveshaft.	b. Install correctly.	6-1
	c. Inadequate lubrication of the driveshaft.	c. Lubricate properly.	6-1
	d. The driveshaft and beater assembly work forward.	d. Call a service technician.	---
	e. Worn rear shell bearing.	e. Call a service technician.	---
	f. Gearbox out of alignment.	f. Call a service technician.	---

Problem	Probable Cause	Remedy	Page Ref.
12.The driveshaft is stuck in the drive coupling.	a. Mix and lubricant collected in drive coupling.	a. Brush-clean the rear shell bearing area regularly.	6-12
	b. Rounded corners of driveshaft, drive coupling, or both.	b. Call a service technician.	---
	c. Gearbox is out of alignment.	c. Call a service technician.	---
13.The freezing cylinder walls are scored.	a. Missing or worn front bearing.	a. Install or replace the front bearing.	6-3
	b. Scraper blades are damaged.	b. Replace scraper blades.	6-2
	c. Machine was placed in Auto before all sanitizing solution was removed from freezing cylinder.	c. Place machine in Auto only after priming is complete and all sanitizing solution is removed.	6-9
	d. Broken freezer door baffle rod.	d. Replace freezer door.	---
	e. Broken beater pins.	e. Replace beater assembly.	6-1
	f. Beater assembly is bent.	f. Replace beater assembly.	---
	g. Gearbox is out of alignment.	g. Call a service technician.	---
14.The product makes a popping sound when drawn.	a. Draw rate is set too fast.	a. Adjust draw rate: 5 oz. to 7-1/2 oz. (142 g to 213 g) of product by weight in 10 seconds.	6-5
	b. Pump assembled incorrectly.	b. Assemble and lubricate according to instructions in this manual.	6-6
	c. Freezing cylinder not primed correctly.	c. Drain the freezing cylinder and reprime the machine.	6-9

Section 9

Parts Replacement Schedule

Table 9-1

Part Description	Every 3 Months	Every 6 Months	Annually
Scraper Blade	X		
Driveshaft Seal	X		
Freezer Door Gasket	X		
Front Bearing	X		
Front Beater Shoes	X		
Design Caps	X		
Draw Valve O-ring	X		
Mix Feed Tube O-ring	X		
Pump O-ring	X		
Prime Plug O-ring	X		
Pump Valve Gasket	X		
Mix Feed Tube Check Ring	X		
Pump Driveshaft O-ring	X		
Bristle Brush, 3" x 7"		Inspect and replace if necessary.	Minimum
Bristle Brush, 1" x 2"		Inspect and replace if necessary.	Minimum
Black Bristle Brush, 1" x 2"		Inspect and replace if necessary.	Minimum
Double-Ended Brush		Inspect and replace if necessary.	Minimum

TAYLOR COMPANY LIMITED WARRANTY ON FREEZERS

Taylor Company is pleased to provide this limited warranty on new Taylor-branded freezer equipment available from Taylor to the market generally (the "Product") to the original purchaser only.

LIMITED WARRANTY

Taylor warrants the Product against failure due to defect in materials or workmanship under normal use and service as follows. All warranty periods begin on the date of original Product installation. If a part fails due to defect during the applicable warranty period, Taylor, through an authorized Taylor distributor or service agency, will provide a new or remanufactured part, at Taylor's option, to replace the failed defective part at no charge for the part. Except as otherwise stated herein, these are Taylor's exclusive obligations under this limited warranty for a Product failure. This limited warranty is subject to all provisions, conditions, limitations, and exclusions listed below and on the reverse (if any) of this document.

Table 10-1

Product	Part	Limited Warranty Period
Soft Serve	Insulated Shell Assembly	Five (5) Years
Frozen Yogurt Shakes	Refrigeration Compressor (except service valve)	Five (5) Years
Smoothies	Beater Motors	Two (2) Years
Frozen Beverage	Beater Drive Gear	Two (2) Years
Batch Desserts	Printed circuit boards and Softech controls beginning with serial number H8024200	Two (2) Years
	Parts not otherwise listed in this table or excluded below	One (1) Years

LIMITED WARRANTY CONDITIONS

1. If the date of original installation of the Product cannot be verified, then the limited warranty period begins ninety (90) days from the date of Product manufacture (as indicated by the Product serial number). Proof of purchase may be required at time of service.
2. This limited warranty is valid only if the Product is installed and all required service work on the Product is performed by a Taylor-authorized distributor or service agency, and only if genuine, new Taylor parts are used.
3. Installation, use, care, and maintenance must be normal and in accordance with all instructions contained in the Taylor Operator's Manual.
4. Defective parts must be returned to the Taylor-authorized distributor or service agency for credit.
5. The use of any refrigerant other than that specified on the Product's data label will void this limited warranty.

LIMITED WARRANTY ON EQUIPMENT

LIMITED WARRANTY EXCEPTIONS

This limited warranty does **not** cover:

1. Labor or other costs incurred for diagnosing, repairing, removing, installing, shipping, servicing, or handling of defective parts, replacement parts, or new Products.
2. Normal maintenance, cleaning, and lubrication as outlined in the Taylor Operator's Manual, including cleaning of condensers.
3. Replacement of wear items designated as Class "000" parts in the Taylor Operator's Manual.
4. External hoses, electrical power supplies, and machine grounding.
5. Parts not supplied or designated by Taylor, or damages resulting from their use.
6. Return trips or waiting time required because a service technician is prevented from beginning warranty service work promptly upon arrival.
7. Failure, damage, or repairs due to faulty installation, misapplication, abuse, no or improper servicing, unauthorized alteration, or improper operation or use as indicated in the Taylor Operator's Manual, including but not limited to the failure to use proper assembly and cleaning techniques, tools, or approved cleaning supplies.
8. Failure, damage, or repairs due to theft, vandalism, wind, rain, flood, high water, water, lightning, earthquake, or any other natural disaster, fire, corrosive environments, insect or rodent infestation, or other casualty, accident, or condition beyond the reasonable control of Taylor; operation above or below the electrical or water supply specification of the Product; components repaired or altered in any way so as to, in the judgment of the Manufacturer, adversely affect performance, or normal wear or deterioration.
9. Any Product purchased over the Internet.
10. Failure to start due to voltage conditions, blown fuses, open circuit breakers, or damages due to the inadequacy or interruption of electrical service.
11. Electricity or fuel costs, or increases in electricity or fuel costs for any reason whatsoever.
12. Damages resulting from the use of any refrigerant other than that specified on the Product's data label will void this limited warranty.
13. Any cost to replace, refill, or dispose of refrigerant, including the cost of refrigerant.
14. **ANY SPECIAL, INDIRECT, OR CONSEQUENTIAL PROPERTY OR COMMERCIAL DAMAGE OF ANY NATURE WHATSOEVER.** Some jurisdictions do not allow the exclusion of incidental or consequential damages, so this limitation may not apply to you.

This limited warranty gives you specific legal rights, and you may also have other rights that vary from jurisdiction to jurisdiction.

LIMITATION OF WARRANTY

THIS LIMITED WARRANTY IS EXCLUSIVE AND IS IN LIEU OF ALL OTHER WARRANTIES, CONDITIONS, AND/OR REMEDIES UNDER THE LAW, INCLUDING ANY IMPLIED WARRANTIES OR CONDITIONS OF MERCHANTABILITY OR FITNESS FOR A PARTICULAR PURPOSE. THE ORIGINAL OWNER'S SOLE REMEDY WITH RESPECT TO ANY PRODUCTS SHALL BE REPAIR OR REPLACEMENT OF DEFECTIVE COMPONENTS UNDER THE TERMS OF THIS LIMITED WARRANTY. ALL RIGHTS TO CONSEQUENTIAL OR INCIDENTAL DAMAGES (INCLUDING CLAIMS FOR LOST SALES, LOST PROFITS, PRODUCT LOSS, PROPERTY DAMAGES, OR SERVICE EXPENSES) ARE EXPRESSLY EXCLUDED. THE EXPRESS WARRANTIES MADE IN THIS LIMITED WARRANTY MAY NOT BE ALTERED, ENLARGED, OR CHANGED BY ANY DISTRIBUTOR, DEALER, OR OTHER PERSON, WHATSOEVER.

LEGAL REMEDIES

The owner **must** notify Taylor in writing by certified or registered letter to the following address, of any defect or complaint with the Product, stating the defect or complaint and a specific request for repair, replacement, or other correction of the Product under warranty, mailed at least thirty (30) days before pursuing any legal rights or remedies.

Taylor Company
750 N. Blackhawk Blvd.
Rockton, IL 61072, U.S.A.

TAYLOR COMPANY LIMITED WARRANTY ON TAYLOR GENUINE PARTS

Taylor Company is pleased to provide this limited warranty on new Taylor genuine replacement components and parts available from Taylor to the market generally (the “Parts”) to the original purchaser only.

LIMITED WARRANTY

Taylor warrants the Parts against failure due to defect in materials or workmanship under normal use and service as follows. All warranty periods begin on the date of original installation of the Part in the Taylor unit. If a Part fails due to defect during the applicable warranty period, Taylor, through an authorized Taylor distributor or service agency, will provide a new or remanufactured Part, at Taylor’s option, to replace the failed defective Part at no charge for the Part. Except as otherwise stated herein, these are Taylor’s exclusive obligations under this limited warranty for a Part failure. This limited warranty is subject to all provisions, conditions, limitations, and exclusions listed below and on the reverse (if any) of this document.

Table 11-1

Parts Warranty Class Code or Part	Limited Warranty Period
Class 103 Parts ¹	Three (3) Months
Class 212 Parts ²	Twelve (12) Months
Class 512 Parts	Twelve (12) Months
Class 000 Parts	No Warranty

LIMITED WARRANTY CONDITIONS

1. If the date of original installation of the Part cannot be otherwise verified, proof of purchase may be required at time of service.
2. This limited warranty is valid only if the Part is installed and all required service work in connection with the Part is performed by a Taylor-authorized distributor or service agency.
3. The limited warranty applies only to Parts remaining in use by their original owner at their original installation location in the unit of original installation.
4. Installation, use, care, and maintenance must be normal and in accordance with all instructions contained in the Taylor Operator’s Manual.
5. Defective Parts must be returned to the authorized Taylor distributor or service agency for credit.
6. This warranty is not intended to shorten the length of any warranty coverage provided pursuant to a separate Taylor Limited Warranty on freezer or grill equipment.
7. The use of any refrigerant other than that specified for the unit in which the Part is installed will void this limited warranty.

^{1, 2} Except that Taylor Part #032129SER2 (Compressor-Air-230V SERV) and Taylor Part #075506SER1 (Compressor-Air-115V 60HZ) shall have a limited warranty period of twelve (12) months when used in Taylor freezer equipment and a limited warranty period of two (2) years when used in Taylor grill equipment.

LIMITED WARRANTY ON PARTS

LIMITED WARRANTY EXCEPTIONS

This limited warranty does **not** cover:

1. Labor or other costs incurred for diagnosing, repairing, removing, installing, shipping, servicing, or handling of defective Parts, replacement Parts, or new Parts.
2. Normal maintenance, cleaning, and lubrication as outlined in the Taylor Operator's Manual, including cleaning of condensers or carbon and grease buildup.
3. Required service, whether cleaning or general repairs, to return the cooking surface assemblies, including the upper platen and lower plate, to an operational condition to achieve proper cooking or allow proper assembly of release sheets and clips as a result of grease buildup on the cooking surfaces, including but not limited to the platen and plate, sides of the shroud, or top of the shroud.
4. Replacement of cooking surfaces, including the upper platen and lower plate, due to pitting or corrosion (or in the case of the upper platen, due to loss of plating) as a result of damage due to the impact of spatulas or other small wares used during the cooking process or as a result of the use of cleaners, cleaning materials, or cleaning processes not approved for use by Taylor.
5. Replacement of wear items designated as Class "000" Parts in the Taylor Operator's Manual, as well as any release sheets and clips for the Product's upper platen assembly.
6. External hoses, electrical power supplies, and machine grounding.
7. Parts not supplied or designated by Taylor, or damages resulting from their use.
8. Return trips or waiting time required because a service technician is prevented from beginning warranty service work promptly upon arrival.
9. Failure, damage, or repairs due to faulty installation, misapplication, abuse, no or improper servicing, unauthorized alteration, or improper operation or use as indicated in the Taylor Operator's Manual, including but not limited to the failure to use proper assembly and cleaning techniques, tools, or approved cleaning supplies.
10. Failure, damage, or repairs due to theft, vandalism, wind, rain, flood, high water, water, lightning, earthquake, or any other natural disaster, fire, corrosive environments, insect or rodent infestation, or other casualty, accident or condition beyond the reasonable control of Taylor; operation above or below the gas, electrical, or water supply specification of the unit in which a part is installed; or Parts or the units in which they are installed repaired or altered in any way so as to, in the judgment of Taylor, adversely affect performance, or normal wear or deterioration.
11. Any Part purchased over the Internet.
12. Failure to start due to voltage conditions, blown fuses, open circuit breakers, or damages due to the inadequacy or interruption of electrical service.
13. Electricity, gas, or other fuel costs, or increases in electricity or fuel costs for any reason whatsoever.
14. Damages resulting from the use of any refrigerant other than that specified for the unit in which the Part is installed will void this limited warranty.
15. Any cost to replace, refill, or dispose of refrigerant, including the cost of refrigerant.
16. **ANY SPECIAL, INDIRECT, OR CONSEQUENTIAL PROPERTY OR COMMERCIAL DAMAGE OF ANY NATURE WHATSOEVER.** Some jurisdictions do not allow the exclusion of incidental or consequential damages, so this limitation may not apply to you.

This limited warranty gives you specific legal rights, and you may also have other rights which vary from jurisdiction to jurisdiction.

LIMITATION OF WARRANTY

THIS LIMITED WARRANTY IS EXCLUSIVE AND IS IN LIEU OF ALL OTHER WARRANTIES, CONDITIONS, AND/OR REMEDIES UNDER THE LAW, INCLUDING ANY IMPLIED WARRANTIES OR CONDITIONS OF MERCHANTABILITY OR FITNESS FOR A PARTICULAR PURPOSE. THE ORIGINAL OWNER'S SOLE REMEDY WITH RESPECT TO ANY PRODUCTS SHALL BE REPAIR OR REPLACEMENT OF DEFECTIVE PARTS UNDER THE TERMS OF THIS LIMITED WARRANTY. ALL RIGHTS TO CONSEQUENTIAL OR INCIDENTAL DAMAGES, (INCLUDING CLAIMS FOR LOST SALES, LOST PROFITS, PRODUCT LOSS, PROPERTY DAMAGES, OR SERVICE EXPENSES) ARE EXPRESSLY EXCLUDED. THE EXPRESS WARRANTIES MADE IN THIS LIMITED WARRANTY MAY NOT BE ALTERED, ENLARGED, OR CHANGED BY ANY DISTRIBUTOR, DEALER, OR OTHER PERSON, WHATSOEVER.

LEGAL REMEDIES

The owner **must** notify Taylor in writing, by certified or registered letter to the following address, of any defect or complaint with the Part, stating the defect or complaint and a specific request for repair, replacement, or other correction of the Part under warranty, mailed at least thirty (30) days before pursuing any legal rights or remedies.

Taylor Company
750 N. Blackhawk Blvd.
Rockton, IL 61072, U.S.A.

