



Place this chapter in the Grill section
of the Equipment Manual.

Manufactured exclusively for
McDonald's® by

Taylor Company
750 N. Blackhawk Blvd.
Rockton, IL 61072

Phone: (815) 624-8333

Toll Free Number

Outside Illinois:

1 (800) 228-8309

Inside Illinois:

1 (800) 851-5639

Fax: (815) 624-8000



Table of Contents

Introduction	Page 1
Safety	Page 1
Parts Identifications/Functions	Page 4
Important to the Operator	Page 10
Equipment Set Up Procedures	Page 12
Menu Screens	Page 16
Daily Cleaning Procedures	Page 24
Troubleshooting Guide	Page 42
Parts Warranty Explanation	Page 46
Ordering/Service Information	Page 47
Non-Scheduled Maintenance	Page 48
System Set-up	Page 48
Menu Items	Page 53
Auto Leveling	Page 61
Wiring Diagrams	Page 62

Warranty

A warranty checkout card is shipped with all new equipment that leaves the factory. The warranty checkout card is packed in an envelope which also contains this operator's manual. Refer to the warranty checkout card and the warranty classifications listed in the Parts Identification/Function section when service is performed on your machine.

It is recommended that the operator take the necessary time to carefully read through the complete warranty information contained in the warranty checkout card. Any questions or unclear statements found within the card should be made clear to you upon delivery of the machine. Thoroughly understand your warranty protection before you begin operation.

For any questions pertaining to the Taylor Warranty, please contact your authorized Taylor Distributor, or Taylor Company, Rockton, Illinois 61072.

This manual is for the exclusive use of licensees and employees of McDonald's Corporation.

INTRODUCTION

The Model C845 has three independent upper platens. It provides automatic leveling of the platens.

The grill is capable of cooking a variety of products and features two cooking options, AUTO and MANUAL.

AUTO Option: The grill automatically detects the product placed on the grill plate (menu items cooked using the clamshell, only) and sets the appropriate cooking parameters.

MANUAL Option: After the operator selects the desired product to be cooked, the grill automatically sets the appropriate cooking parameters.

These grills provide all the features of a flat grill, as well as the advantages of two-sided cooking.



All repairs must be performed by an authorized Taylor service agent. The main power supplies to the grill must be disconnected prior to performing any repairs.

Note: This grill is designed for indoor use only.

SAFETY

Always follow these safety precautions when operating the grill:



DO NOT operate the grill without reading this operator's manual. Failure to comply may result in equipment damage or personal injury. This manual should be kept in a safe place for future reference.



DO NOT operate the grill unless it is properly grounded. Failure to comply may result in equipment damage or personal injury.



DO NOT install the unit in an area where a water jet could be used. **DO NOT** use a water jet to clean or rinse the grill. Failure to follow this instruction may result in serious electrical shock. In addition, water may collect inside the grill and destroy electrical components and cause injury from hot steam.



This unit is provided with an equipotential grounding lug that is to be properly attached to the rear of the frame by the authorized installer. The installation location is marked by the equipotential bonding symbol (5021 of IEC 60417-1) on both the removable panel and the equipment's frame.



- **DO NOT** operate the grill with larger fuses than specified on the data label.
- All repairs must be performed by an authorized Taylor service agent.
- The main power supplies to the grill must be disconnected prior to performing any repairs.
- Stationary appliances which are not equipped with a power cord and a plug or other device to disconnect the appliance from the power source must have an all-pole disconnecting device with a contact gap of at least 3 mm installed in the external installation.
- Appliances that are permanently connected to fixed wiring and for which leakage currents may exceed 10 mA, particularly when disconnected or not used for long periods, or during initial installation, shall have protective devices such as a GFI, to protect against the leakage of current, installed by the authorized personnel to the local codes.

- Supply cords used with this unit shall be oil-resistant, sheathed flexible cable, not lighter than ordinary polychloroprene or other equivalent synthetic elastomer-sheathed cord, (Code designation 60245 IEC 57) installed with the proper cord anchorage to relieve conductors from strain, including twisting, at the terminals and protect the insulation of the conductors from abrasion.
- If the supply cord is damaged, it must be replaced by a Taylor authorized service technician.

Failure to follow these instructions may result in personal injury, equipment damage, or poor grill performance.

WARNING: Improper installation, adjustment, alteration, service or maintenance can cause property damage, injury or death. Read the installation, operating, and maintenance instructions thoroughly before installing or servicing this equipment.



- This appliance must be isolated from all combustible construction and materials, including, but not limited to; walls, partitions, furniture, floors, curtains, paper, boxes, and decorations. Failure to comply may result in a fire and cause destruction and severe injury.

 **FOR YOUR SAFETY**
Do not store or use gasoline or other flammable vapors or liquids in the vicinity of this or any other appliance.



- **DO NOT** obstruct the ventilation openings at the rear of this appliance.
- **DO NOT** obstruct the flow of air in and around the grill.
- **DO NOT** operate the grill unless all service panels and access doors are attached with screws. Failure to comply may result in personal injury from gas or electrical components.



USE EXTREME CAUTION while setting up, operating, and cleaning the grill. Avoid coming in contact with hot grill surfaces or hot grease. Failure to comply will result in burn injuries.



- The grill must be placed on a level surface.
- To ensure thorough cleaning, the grill must be pulled away from the wall. Before moving the grill, remove the grease cans. Turn off the gas at the quick connect shut-off valve on the flexible hose. Disconnect the gas quick connector. Disconnect the restraining means to the front caster stems. To return the grill to its original position, reverse the steps. Use extreme caution to smoothly and slowly roll the grill backward into place.

Failure to follow these instructions may cause the grill to tip and can result in severe equipment damage or personal injury.



NOTICE all warning labels that have been attached to the grill to further point out safety precautions to the operator.



Per IEC 60335-1 and its part 2 standards, "This appliance is to be used only by trained personnel. It is not intended for use by children or people with reduced physical, sensory, or mental capabilities, or lack of experience and knowledge, unless given supervision or instruction concerning the use of the appliance by a person responsible for their safety."

HAZARD COMMUNICATION STANDARD (HCS) - The procedure(s) in this manual include the use of chemical products. These chemical products will be highlighted with bold faced letters followed by the abbreviation (HCS) in the text portion of the procedure. See the Hazard Communication Standard (HCS) manual for the appropriate Material Safety Data Sheet(s) (MSDS).

This piece of equipment is made in America and has American sizes on hardware. All metric conversions are approximate and vary in size.

NOISE LEVEL: Airborne noise emission does not exceed 70 dB(A) when measured at a distance of 1.0 meter from the surface of the machine and at a height of 1.6 meters from the floor.

These instructions are valid only if the country code symbol appears on the appliance. If the symbol does not appear on the appliance, refer to the technical instructions which give the necessary instructions for adapting the appliance to the utilization conditions of that country.



If the crossed out wheeled bin symbol is affixed to this product, it signifies that this product is compliant with the EU Directive as well as other similar legislation in effect after August 13, 2005. Therefore, it must be collected separately after its use is completed, and cannot be disposed as unsorted municipal waste.

The user is responsible for returning the product to the appropriate collection facility, as specified by your local code.

For additional information regarding applicable local laws, please contact the municipal facility and/or local distributor.

PARTS IDENTIFICATION/FUNCTIONS

C845 Exploded View (See Figure 1)

ITEM	PART NO.	DESCRIPTION	QTY.	FUNCTION	WARR. CLASS
1	X78330-SER	Kit A.-Grease Shield	3	Prevents grease migration.	103
1a	078329	Fastener-Snap in 1/4 x 15/16	24	Fastens the grease shield to the grill.	000
1b	078285	Shield-Grease	4	Prevents grease migration.	000
2	X73680	Panel A.-Back Panel	1	Provides access to internal components for service and cleaning.	103
3	024298	Screw-10-32 x 3/8	19	Secures the panels to the frame.	000
4	073353	Panel-Side Upper Right	1	Provides access to internal components for service and cleaning.	103
5	073345-R	Panel-Side	1	Provides access to internal components for service and cleaning.	103
6	078377	Caster-5" 7-5/8 Stem	2	Allows grill mobility.	103
7	073240	Caster-Grill 5" Swivel w/Lock	2	Prevents grill movement.	103
8	X72491-SER	Control-Display	3	Controls all functions of the grill.	103
9	076989-WP	Switch-Rocker-DPST 10A	1	Activates power to the grill and the exhaust fans.	103
10	076012	Button-Operator-Black (Standby)	3	Activates the cook cycle, keeps the upper platen in the closed position, and displays the message "STANDBY" on the control. When pressed twice within five seconds, the upper platen will automatically lower into the Standby position.	000
11	076011	Button-Operator-Red (Raise)	3	Cancels the Standby mode, raises the upper platen, and deactivates the Cook cycle.	000
12	039381	Screw-10-32 x 3/8	14	Secures the panel to the lower cook surface.	000
13	073352	Panel-Side Upper Left	1	Provides access to internal components for service and cleaning.	103
14	073345-L	Panel-Side	1	Provides access to internal components for service and cleaning.	103
15	075288	Guard-Lense (International Only)	3	Protects the Standby button from being accidentally activated.	103

C845 Exploded View

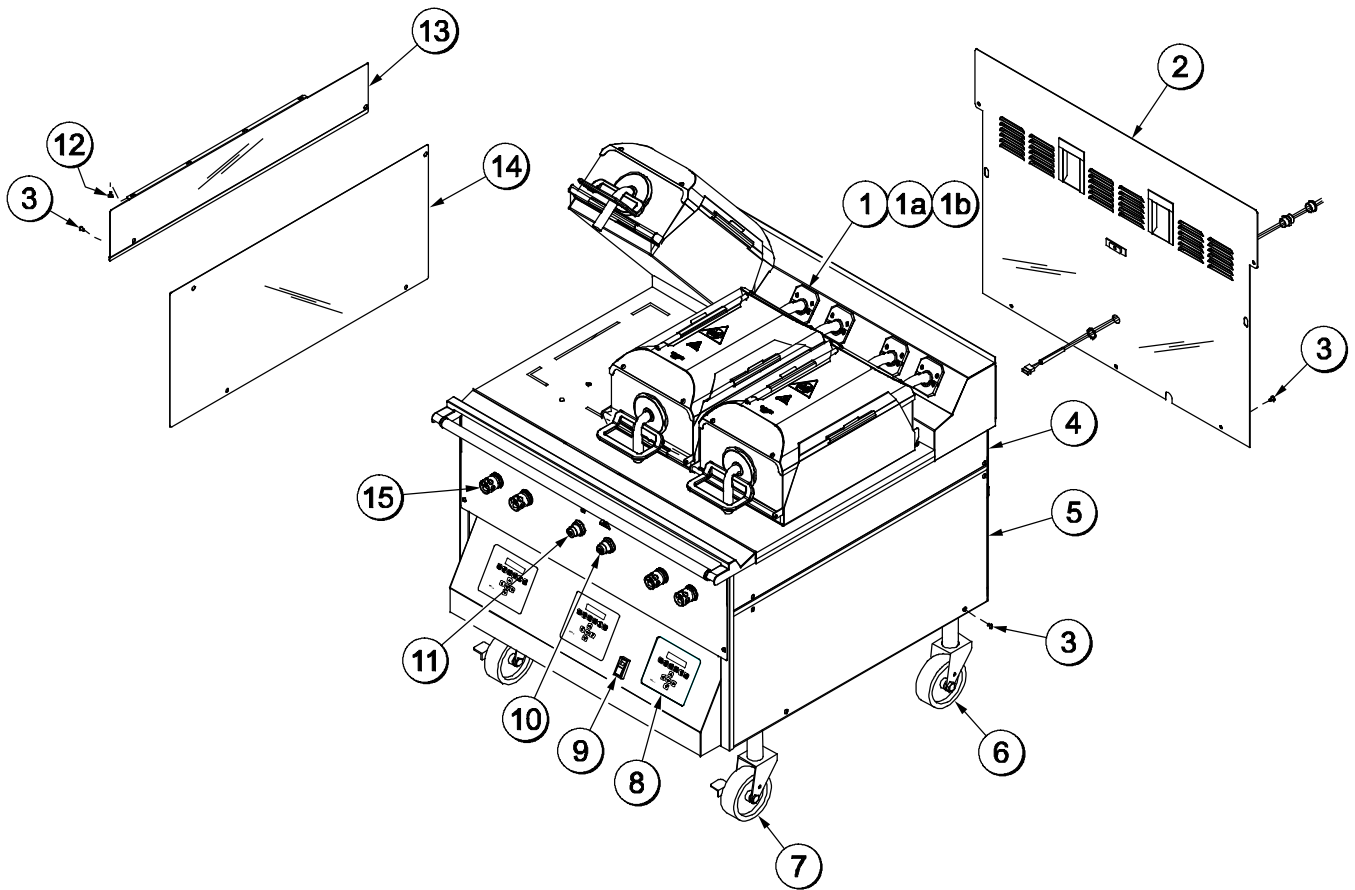

Figure 1

C845 Front View

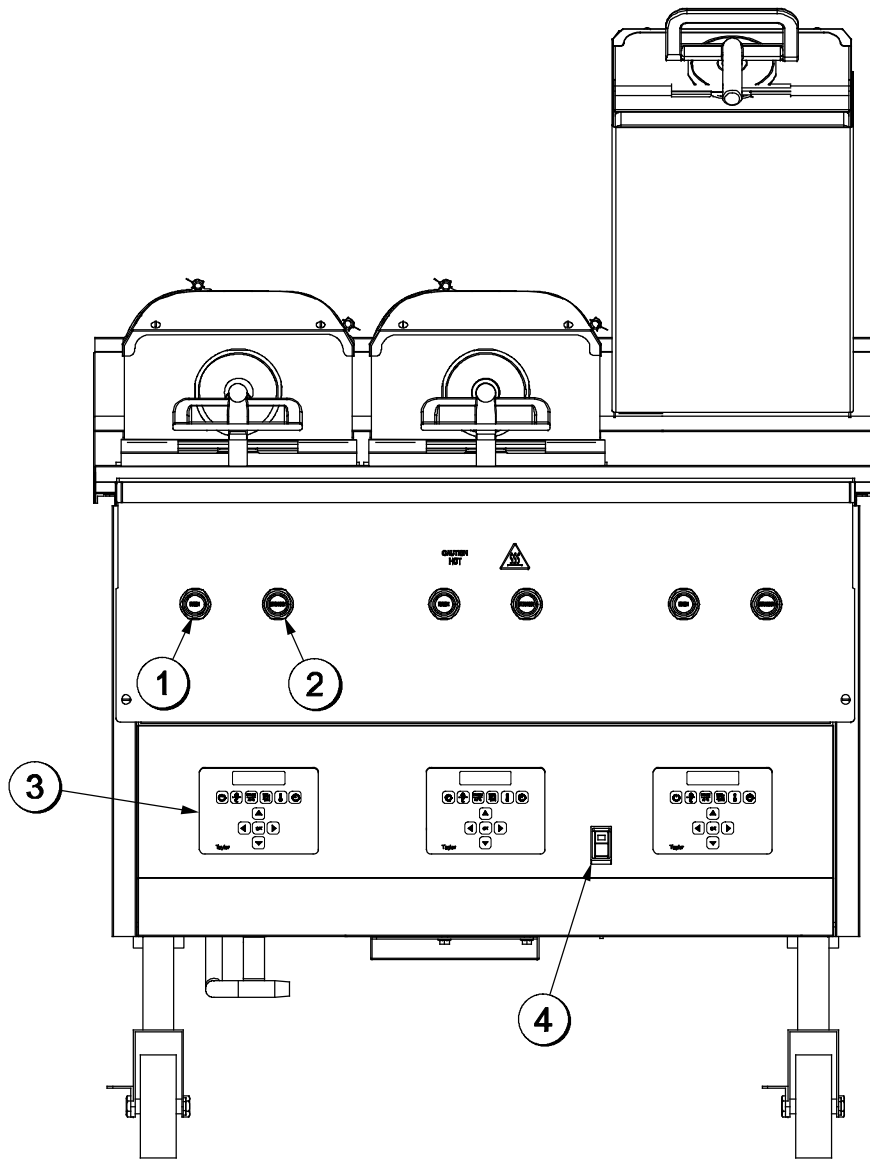

Figure 2

ITEM	PART NO.	DESCRIPTION	QTY.	FUNCTION	WARR. CLASS
1	076011	Button-Operator-Red (Raise)	3	Cancels the Standby mode, raises the upper platen, and deactivates the Cook cycle.	000
2	076012	Button-Operator-Black (Standby)	3	Activates the cook cycle, keeps the upper platen in the closed position, and displays the message "STANDBY" on the control. When pressed twice within five seconds, the upper platen will automatically lower into the Standby position.	000
3	X72491-SER	Control-Display	3	Controls all functions of the grill.	103
4	076989-WP	Switch-Rocker-DPST 10A	1	Activates power to the grill and the exhaust fans.	103

C845 Right Side View

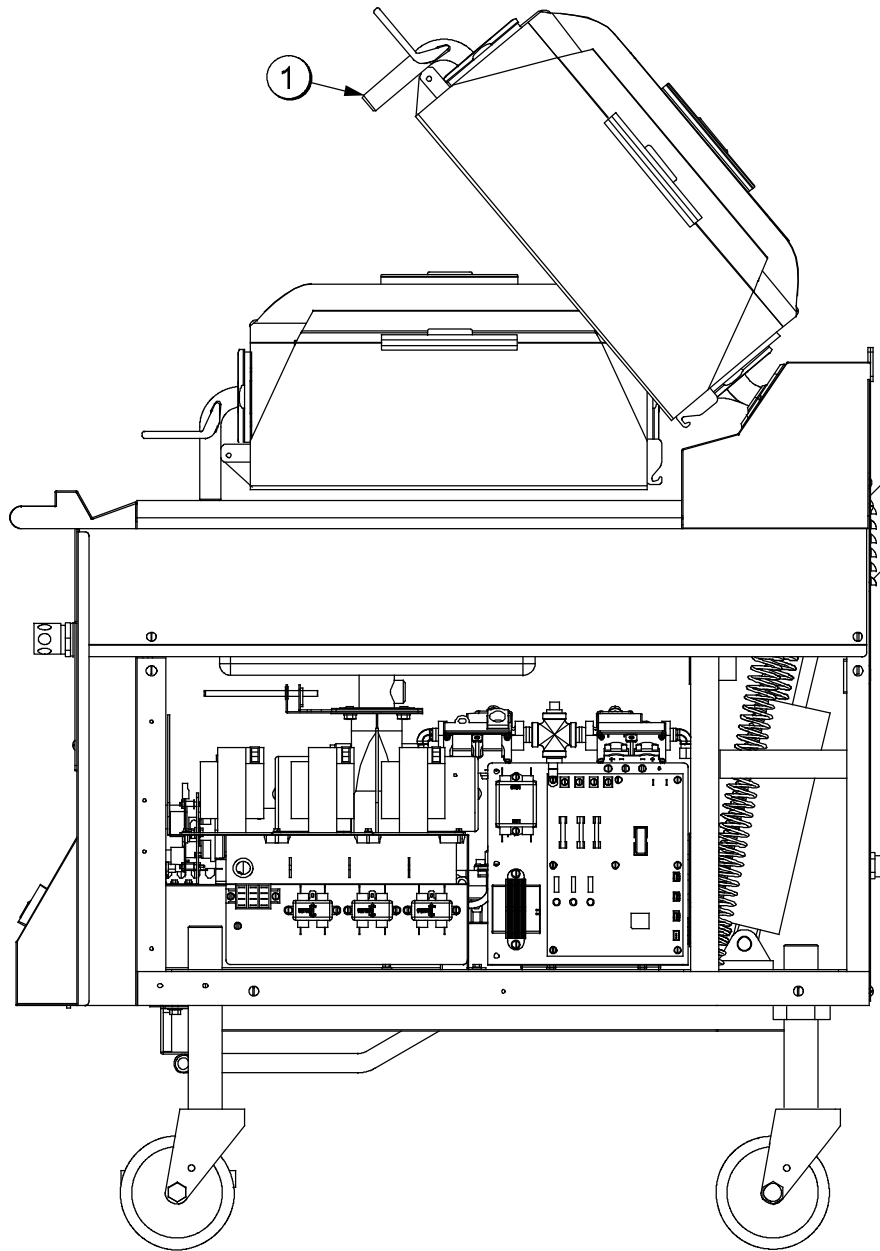

Figure 3

ITEM	PART NO.	DESCRIPTION	QTY.	FUNCTION	WARR. CLASS
1	072472	Handle-Platen	3	The handle sits solidly on the lower cook surface when the platen is lowered.	103

C845 Left Side View

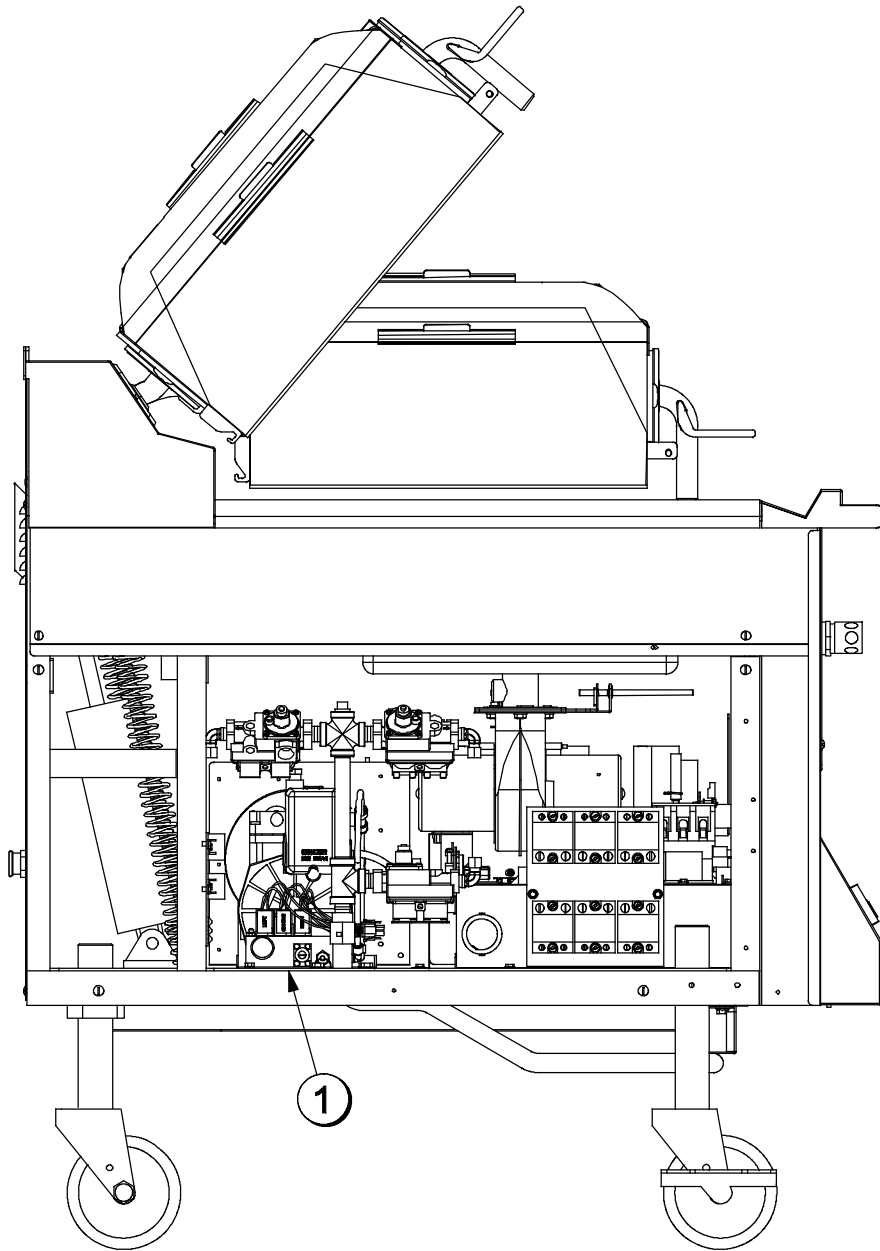

Figure 4

ITEM	PART NO.	DESCRIPTION	QTY.	FUNCTION	WARR. CLASS
1	072695	Manifold A.	1	Regulates air pressure for platen operation.	103

Accessories

ITEM	PART NO.	DESCRIPTION	QTY.	FUNCTION	WARR. CLASS
1	073338	Rod-Release Material	3	Secures the hemmed end of the release material sheet to the rear of the platen.	000
2	072673	Clip-Release Material w/Tab	9	Secures the release material sheet to the front and sides of the platen.	000
3	073337	Sheet-Release Box of 9	1	Non-stick barrier used to protect the upper platen.	000
4	073677	Hose A.-Flexible Gas	1	Supplies the gas to the unit.	103
*5	081432	Sheet-Lower Release (Box of 12)	1	Non-stick barrier used to protect the lower cook surface.	000

*For grill markets using lower release sheet, only.

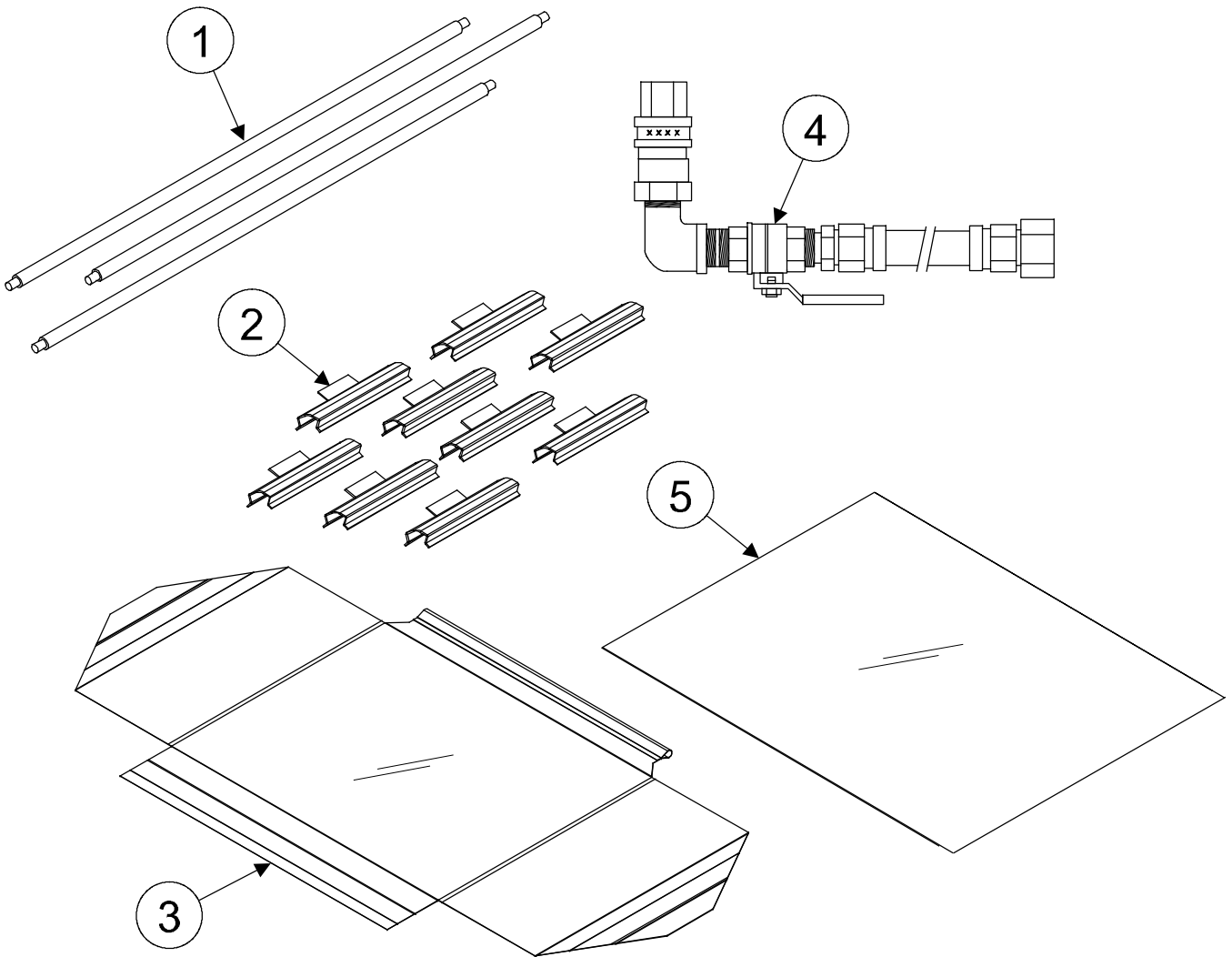

Figure 5

IMPORTANT TO THE OPERATOR

Important to the Operator Parts Identification (See Figure 6.)

ITEM	DESCRIPTION	FUNCTION
1	Fan Interlock Switch	This switch activates power to the grill and the exhaust fans.
2	ON/OFF Key	This key is used to turn the controller on and off to start a preheating mode and to auto-gap the platen. The key must be pressed and held for three seconds to activate, in order to prevent unintended operation.
3	AM/PM Key	This key is used to toggle back and forth between the AM and PM menu item lists.
4	MANUAL/AUTO Key	This key is used to toggle back and forth between the Manual and Auto modes.
5	Left Arrow Key	This key is used to scroll through menu items when cooking in the Manual mode. (Inactive in the Auto mode.)
6	Down Arrow Key	While in the Menu mode, this key is used to decrease a numerical value and to scroll through the characters when entering a new menu item or modifying an old one. (Inactive in the Auto mode.)
7	OK Key	This key is used to accept the information entered.
8	Right Arrow Key	This key is used to scroll through menu items when cooking in the Manual mode. (Inactive in the Auto mode.)
9	Up Arrow Key	While in the Menu mode, this key is used to increase a numerical value and to scroll through the characters when entering a new menu item or modifying an old one. (Inactive in the Auto mode.)
10	Program Key	This key is used to enter and exit the Programming mode.
11	Temperature Key	When pressed and held for 3 seconds, this key will access the Probe Calibration screen.
12	Cook Time Key	This key is used to change the remove time of a specific menu item. To change a specific cook time, the item must be selected in the Manual mode. (Note: Press and hold the Cook Time key for three seconds to activate.)
13	Liquid Crystal Display	This screen displays menu options and information.

Important to the Operator

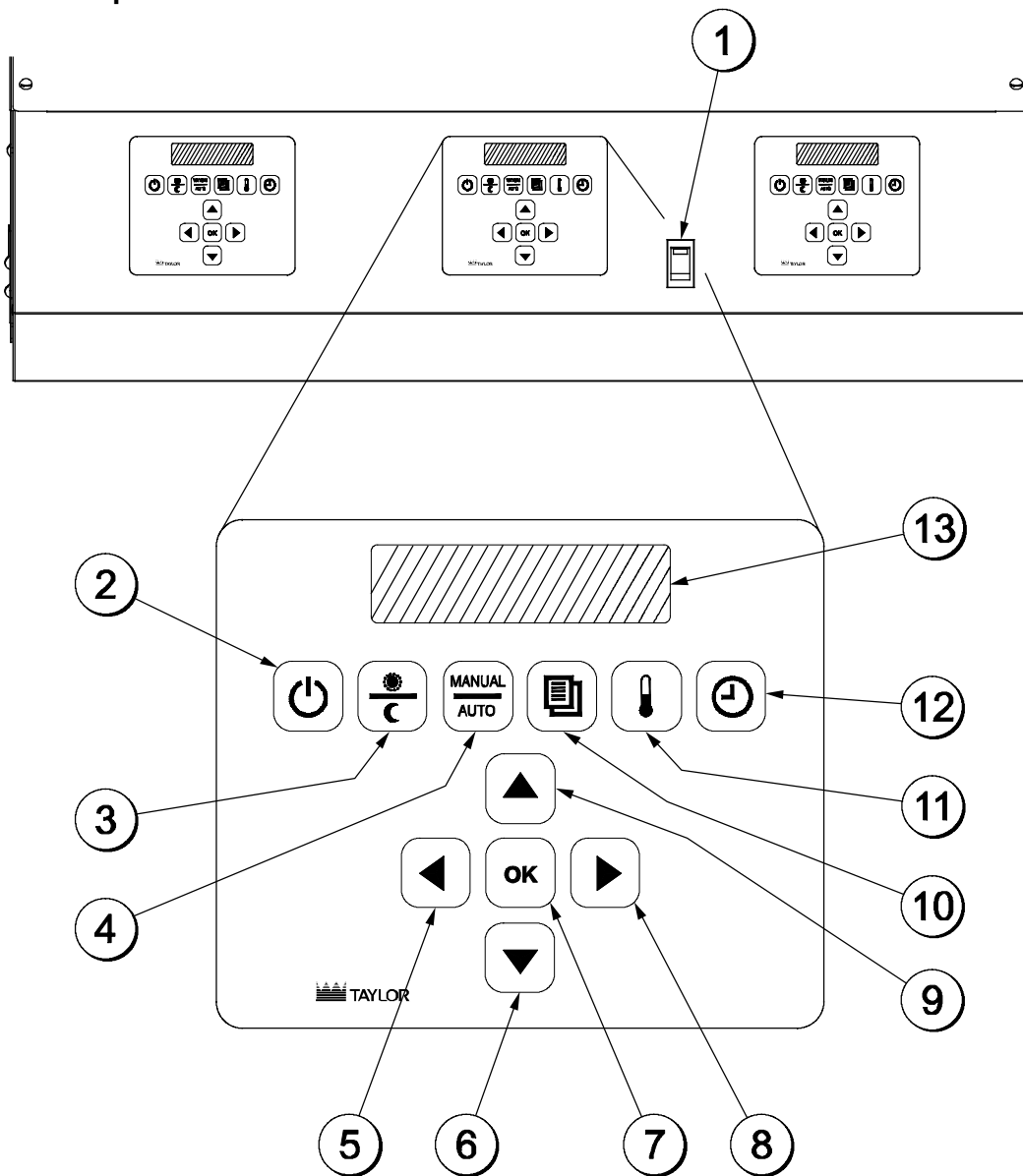



Figure 6

Symbol Definitions

To better communicate in the International arena, the words on many of our operator keys have been replaced by symbols to indicate their functions. Your Taylor equipment is designed with these International symbols.

The following chart identifies the symbol definitions.

 = ON/OFF

 = AM/PM

 = PROGRAM

 = TEMPERATURE

 = TIME

EQUIPMENT SET-UP PROCEDURES

Installing Upper Release Material Sheets

1. Slide the release material retention bar through the loop in the release sheet. (See Figure 7.)

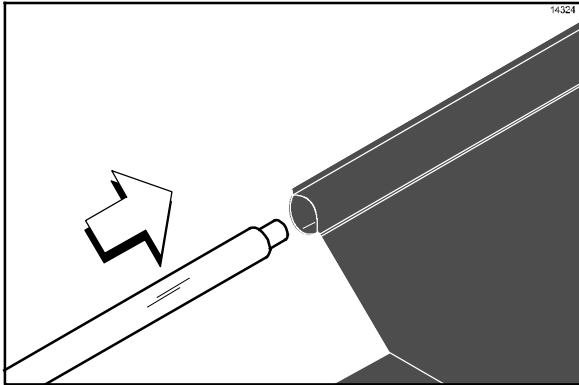

Figure 7

2. Engage the material retention bar into the hooks provided on the shroud. (See Figure 8.)

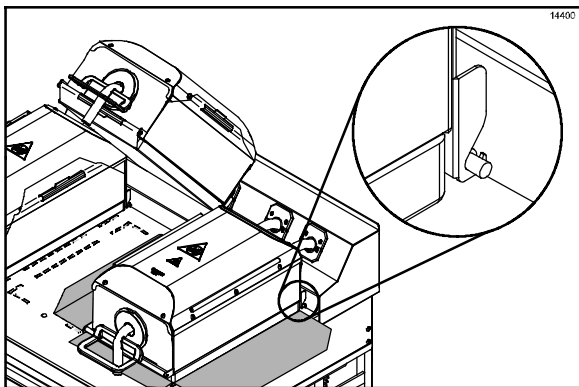

Figure 8

3. Center the release sheet on the bar. Pull it tightly over the release material bar located in the front of the shroud. Secure the sheet with a locking clip. (See Figure 9.)

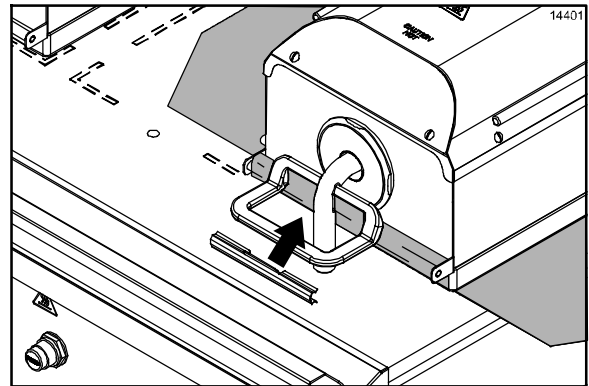

Figure 9

4. Carefully rotate the release sheet side flaps over the cover rails and secure the sheet with locking clips. (See Figure 10.)

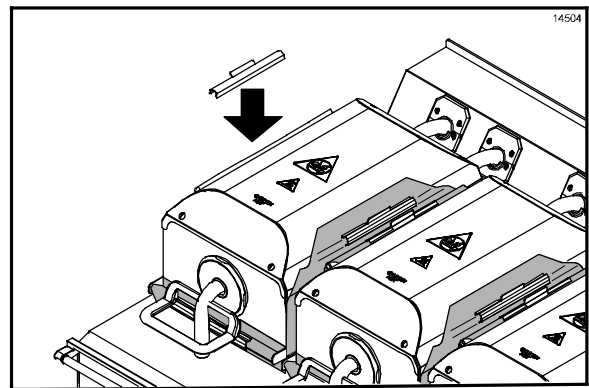

Figure 10

IMPORTANT! Do not crease the release sheet. This will greatly reduce the life of the sheet.

5. Make sure the release sheets are tight across the upper platen surface.
6. **Repeat these steps** for the other upper platens.

Installing Lower Release Sheets (Grills Using Lower Release Sheets)

Note: The following steps pertain to grill markets using lower release sheets, only. **If your grill does not use lower release sheets, proceed to “Start-Up of the Grill” on page 15.**



WARNING! Upper release sheets cannot be used on the lower grill surface. Poor quality and potential food safety issues may occur.

1. Clean the grill with a sanitizer-soaked grill cloth to remove any debris on the grill. (See Figure 11.)

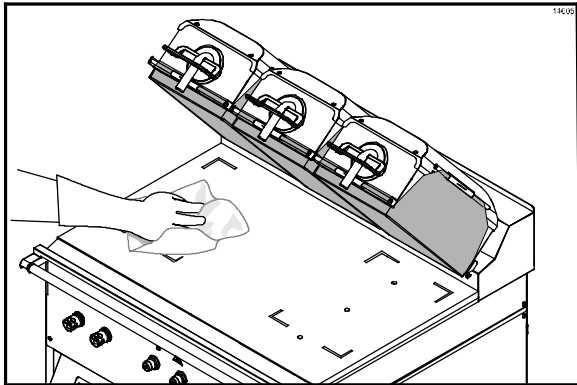

Figure 11

2. Place the fan interlock switch in the ON position. The controller will display the message “OFF”. (See Figure 12.)

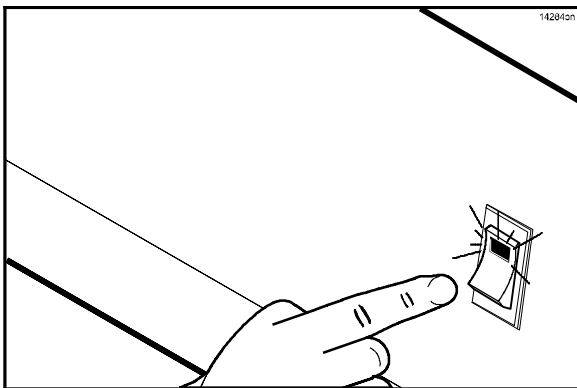



Figure 12

3. Press the  key for 3 - 5 seconds. “AM TOO COOL” and “AM FOLDED EGGS - CLAM” will be displayed on the control screen.

4. The screen will then display, “CLEAN GRILL SURFACES,” followed by “CLOSE PLATEN FOR AUTO LEVELING.”
5. Using a sundae spoon, distribute two level spoonfuls of soy adherence flakes over a warm 3 ft. (1 m.) grill surface, allowing the flakes to melt. (See Figure 13.)

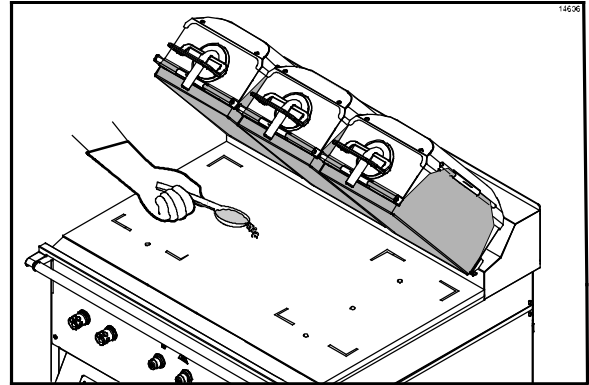

Figure 13

6. Using a clean squeegee, spread the flakes on the cooking zone. (See Figure 14.)

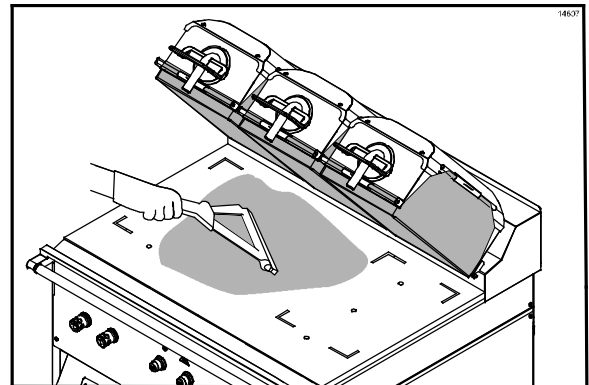

Figure 14

7. Put on heat-resistant gloves. (See Figure 15.)

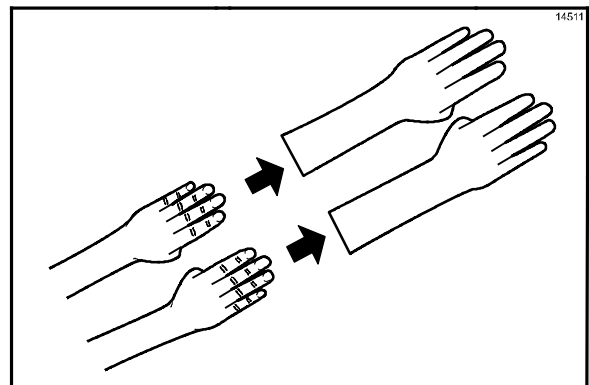

Figure 15

8. With the narrow side of the lower release sheet facing the back of the grill, hold the release sheet about one inch from the end of each side. Align the back edge of the release sheet with the back splash and the side edge of the grill. (See Figure 16.)

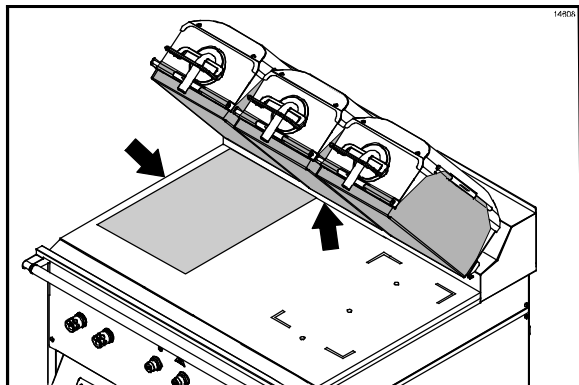

Figure 16

9. Using the grill squeegee, gently squeegee out air bubbles, making sure not to crease or fold the release sheet. (See Figure 17.)

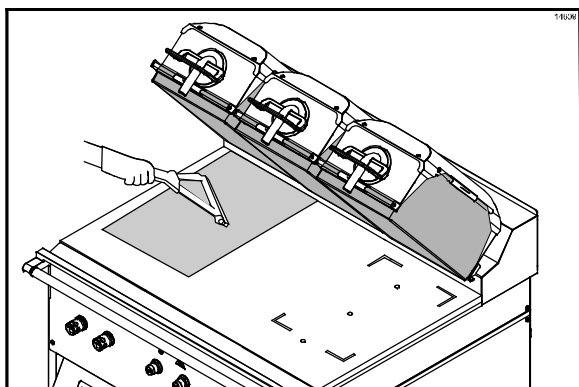

Figure 17

10. Repeat the last two steps for the release sheet on the other side of the grill. (See Figure 18.)

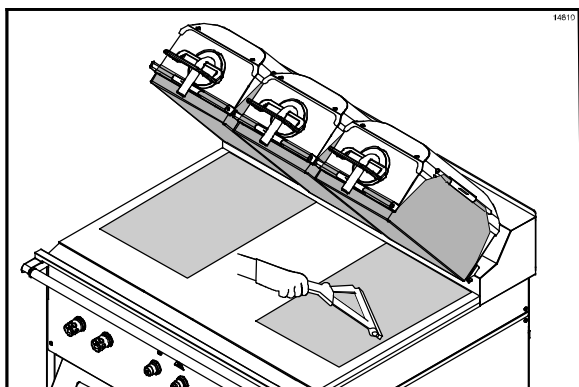

Figure 18

11. Align the back edge of the third lower release sheet with the back splash and middle of the grill. The release sheet will overlap the edge of the other two release sheets. (See Figure 19.)

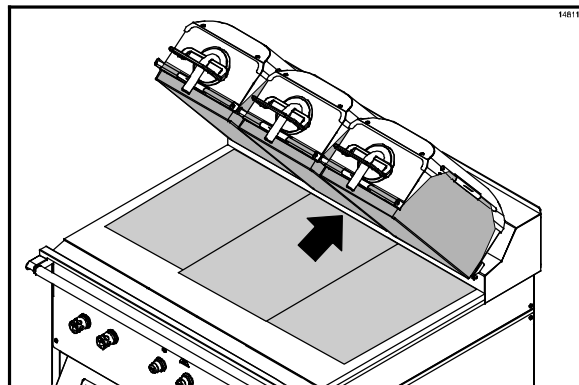

Figure 19

12. Use the squeegee to gently remove the air bubbles.

Note: When properly applied, the release sheets will lay flat, with only a few small air bubbles.

13. Press the Standby button to close the platen. (See Figure 20.)

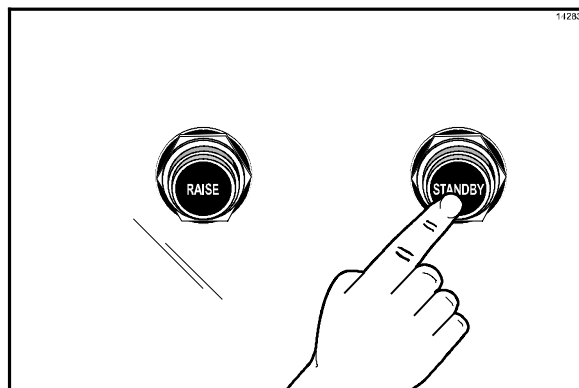

Figure 20

14. After the platen has closed, the grill will start heating up to the proper temperature. The control will display the following message until the grill has reached the proper temperature, "TOO COOL FOR AUTO LEVELING".
15. When the grill has reached the proper temperature, the screen will display, "PLEASE WAIT FOR AUTO LEVELING".
16. When the Auto Leveling is complete, the upper platen will raise. The screen will display the product that had been selected.

The release sheet must be changed when:

- Product sticks to the release sheet.
- Carbon builds up, causing problems in taste or appearance.
- There is a tear in the release sheet in the cooking area.
- The release material substance is worn from the release sheet.

Note: Rotate and reverse the release sheets on a daily basis.

Care of Release Material Sheets

- **DO NOT** fold or crease.
- **DO NOT** touch with any sharp object or abrasive.
- **DO NOT** hose with hot water or soak in water.
- **DO NOT** place under other objects.

Start-Up of the Grill

IMPORTANT: The lower grill plate and the upper platen **MUST BE CLEAN** before starting these procedures.

Note: Grills that use lower release sheets require start up of grill before installation of lower release sheets. (See page 13.)

1. Place the fan interlock switch in the ON position. The controller will display the message "OFF". (See Figure 21.)

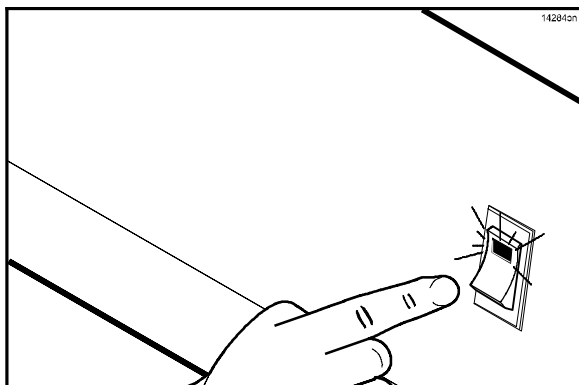



Figure 21

2. Heat up the grill by pressing the  key for 3 - 5 seconds. "AM TOO COOL" and "AM FOLDED EGGS - FLAT" will be displayed on the control screen. (See Figure 22.)

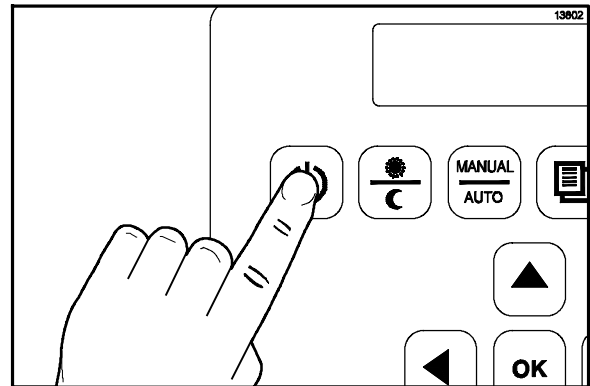

Figure 22

3. The control will first display, "CLEAN GRILL SURFACES". Then the control will display, "CLOSE THE CLAM FOR AUTO LEVELING."
4. Press the Standby button to close the platen. (See Figure 23.)

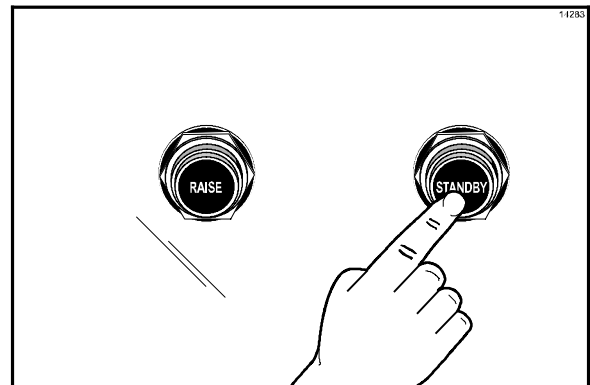

Figure 23

5. After the platen has closed, the grill will start heating up to the proper temperature. The control will display the following message until the grill has reached the proper temperature, "TOO COOL FOR AUTO LEVELING".
6. When the grill has reached the proper temperature, the screen will display, "PLEASE WAIT FOR AUTO LEVELING".
7. When the Auto Leveling is complete, the upper platen will raise. The screen will display the product that had been selected.

MENU SCREENS

Limited access to menu screens is available through the Operator Menu or the Manager Menu. In order to enter the Operator Menu or the Manager Menu, individual passcodes must be entered.

Operator Menu - Passcode Access

The Operator Menu gives limited MENU and SYSTEM SETUP access. Access to this menu is intended for day to day operations (whomever is responsible for Beef Integrity).

To enter the Operator Menu, press the  key to display "PROGRAMMING." Press the

 key to display the passcode entry screen. Enter the Operator Menu passcode by pressing the keys in this order:

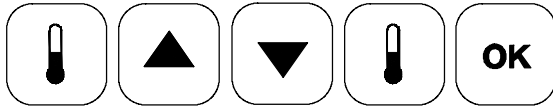

All menu items will be visible, except "ADD ITEM". The following parameters are available for each menu item:

- AM/PM
- REMOVE IN
- REMOVE ALARM

The following SYSTEM SETUP parameters will be available:

- PROBE CALIBRATION
- TEMPERATURE DISPLAY
- AUTO CLOSE
- SPEAKER VOLUME
- TOO COOL DELAY

Manager Menu - Passcode Access

The Manager Menu gives access to all MENU items and limited SYSTEM SETUP access. To

access the Manager Menu, press the  key to display "PROGRAMMING." Press the

 key to display the passcode entry screen. Enter the Manager Menu passcode by pressing the keys in this order:

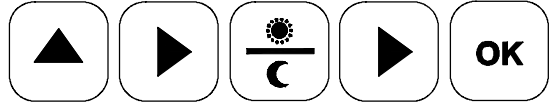

All MENU items will be visible, including "ADD ITEM". All parameters are available for each menu item.

The following SYSTEM SETUP parameters will be available, in addition to those available in the Operator Menu.

- AUTO PROD MELT TIME
- GATEWAY ENABLE
- DATE
- TIME
- 24 HOUR STORE

Product Selection



The  key allows the operator to cook in either the AUTO mode or in the MANUAL mode.

AUTO Mode





In the AUTO mode, the grill automatically detects the product that is placed on the lower grill plate and sets the appropriate cooking parameters. **The AUTO option is only available for clam items.**

Note: In “MENU ITEMS”, the **AUTO SELECTION** parameter must be set to “YES”.

MANUAL Mode

In the MANUAL mode, the operator selects the desired product to be cooked.

To select a product using the MANUAL item option, perform the following steps.

1. Press the  key. “AM” will be displayed on the control screen. If “PM” is desired, press the  key one more time.
2. Use the  or  keys to scroll through the various product menu selections. Continue this process until the desired product is displayed. The product that is displayed will be selected.

Patty Placement

Placement procedures of meat products must be followed on the grill. Meat must be placed on the lower grill plate, two patties at a time, from front to back, per the patty placement guide on page 18. When the cook cycle is complete, the upper platen will raise.

The patties must be removed immediately after the upper platen has been raised to the OPEN position and the meat has been seasoned. Remove the patties, one at a time, from front to back and right to left, per the patty placement guide on page 18.

The maximum amount of meat patties to be cooked on each cook zone of the grill is as follows.

- 8 regular (10:1) patties
- 6 quarter pound (4:1) patties
- 4 Angus patties
- 8 sausage patties
- 6 circular bacon

The following chart is to be used as the patty placement guide.

**Model C845
IntelliGap™ Grill
10:1, 4:1, Sausage, Circular Bacon,
and Patty Placement Guide**

Patties laying pattern

NOTE:
Lay the patties on
the grill two at a time
from front to back.

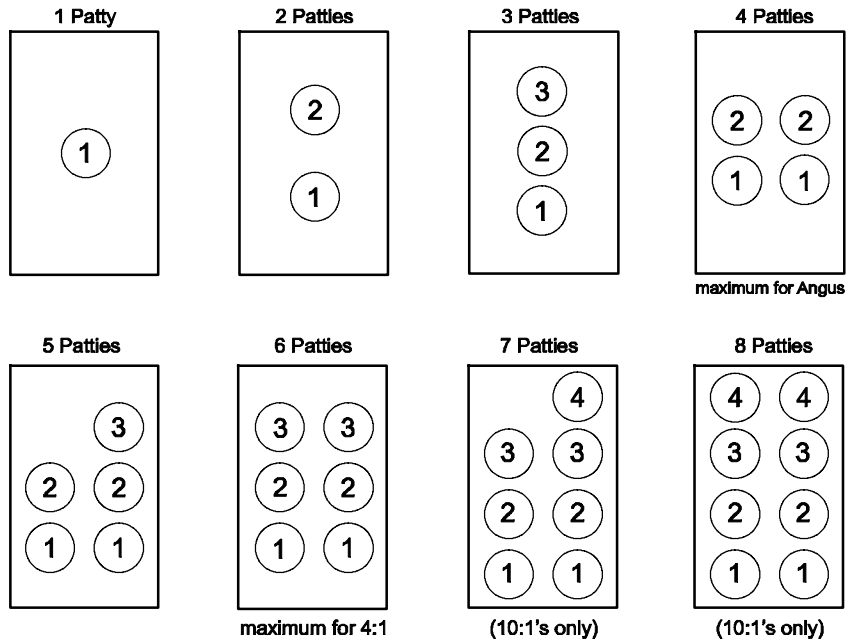

Patties pulling pattern

NOTE:
Remove the patties
one at a time in the
order shown –
from front to back,
right to left.

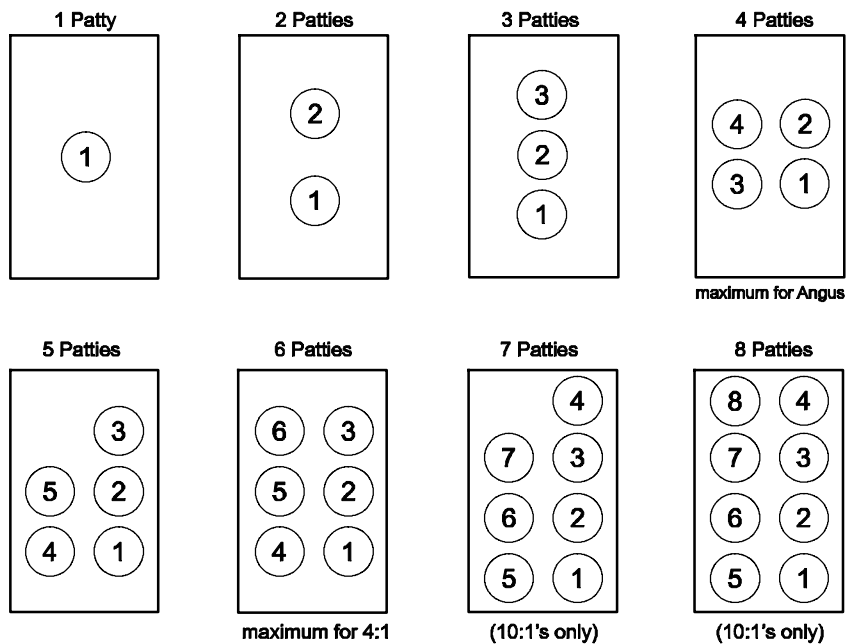

Figure 24

Note: Patty placement procedures for International Markets may differ. Follow the recommendations of your local McDonald's authorities.

Standby Procedures

Whenever the grill is idle and product is not being cooked, the upper platen must be placed in the STANDBY position.

1. To place the upper platen in the STANDBY position, press the STANDBY button twice from the open position. (See Figure 25.)

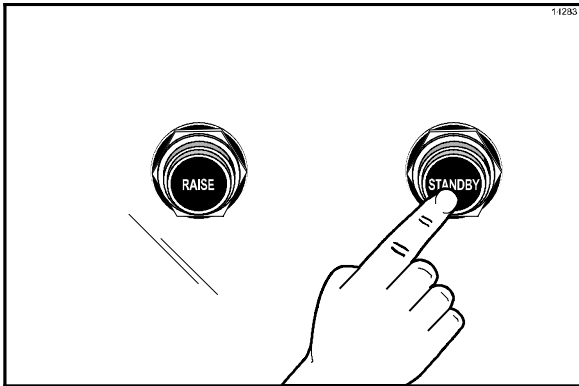

Figure 25

2. To raise the upper platen to the OPEN position to resume cooking, press the RAISE button. (See Figure 26.)

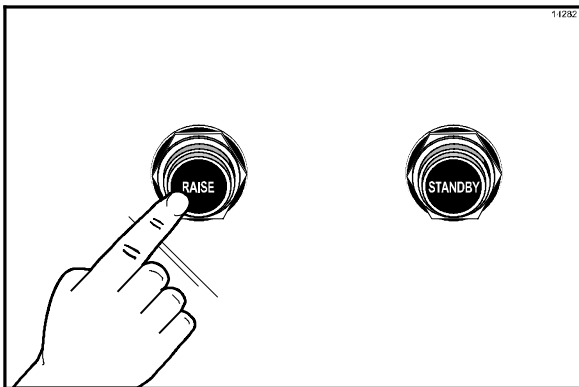

Figure 26

Note: If the grill remains idle for 5 continuous minutes without being placed in STANDBY, a tone will sound and the display will flash "PUT GRILL IN STANDBY".



CAUTION: NEVER USE FORCE TO RAISE THE UPPER PLATEN. DAMAGE TO COMPONENTS WILL RESULT. USE ONLY THE RAISE BUTTON TO OPEN THE UPPER PLATEN!

Cleaning After Each Run of Product (Grills Using Lower Release Sheets)

Note: This manual contains separate procedures for grills that use lower release sheets and for grills that do not use lower release sheets. Use the appropriate procedures for your grill.

If your grill does not use lower release sheets, go to page 20.

1. Squeegee the lower release sheet from front to back. (See Figure 27.)

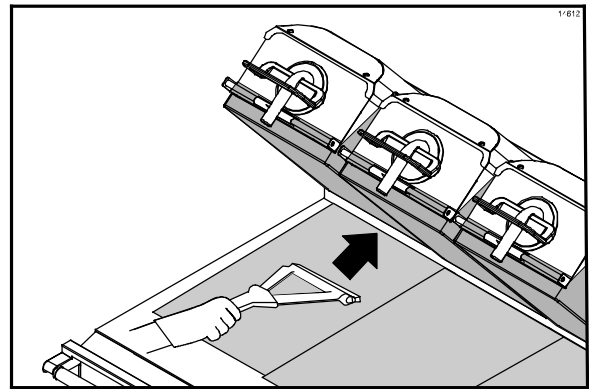

Figure 27

2. Squeegee the upper release sheet from top to bottom. (See Figure 28.)

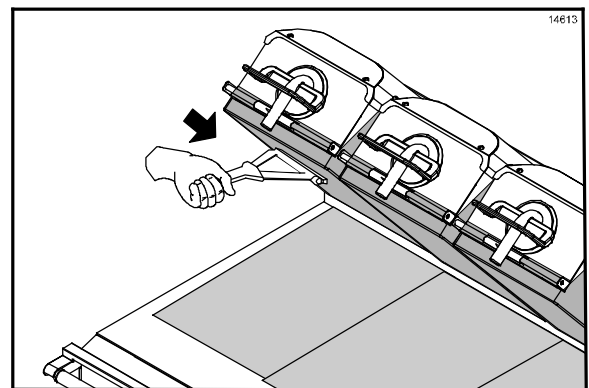

Figure 28

3. Push the residue into the grease trough. (See Figure 29.)

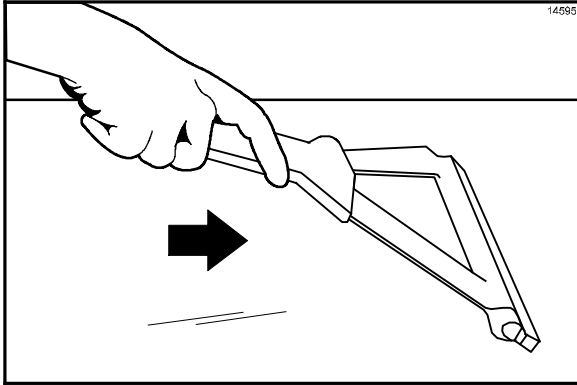

Figure 29

Note: Do not use excessive pressure when wiping the release sheet. Using excessive pressure can scratch or tear the release sheet.

4. Carefully squeegee the air bubbles from center to side, making sure the release sheet does not become folded or creased. (See Figure 30.)

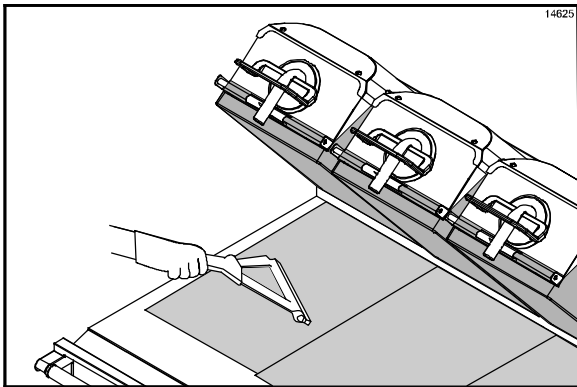

Figure 30

5. Wipe the squeegee with a sanitizer-soaked grill cloth.
6. Wipe the top platens and grill surface 4 times an hour with a sanitizer-soaked grill cloth.
7. As needed during operation, use a sanitizer-soaked grill cloth to clean the back splash plate and bullnose areas.



CAUTION: THE UPPER PLATENS AND LOWER COOK SURFACE ARE HOT! TO PREVENT BURN INJURIES, USE EXTREME CAUTION WHEN WIPING THE RELEASE MATERIAL SHEETS.

Cleaning After Each Run of Product (Grills Not Using Lower Release Sheets)

Note: This manual contains separate procedures for grills that use lower release sheets and for grills that do not use lower release sheets. Use the appropriate procedures for your grill.

IMPORTANT! If your grill uses lower release sheets, follow the instructions starting on page 19. Failure to follow this instruction will result in equipment damage and poor grill performance.

1. Using the grill scraper, scrape the grease on the lower grill plate from front to back. **Do not** scrape across the rear of the lower grill plate with the grill scraper. (See Figure 31.)

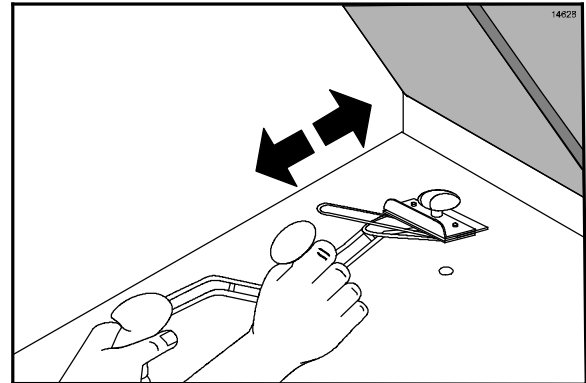
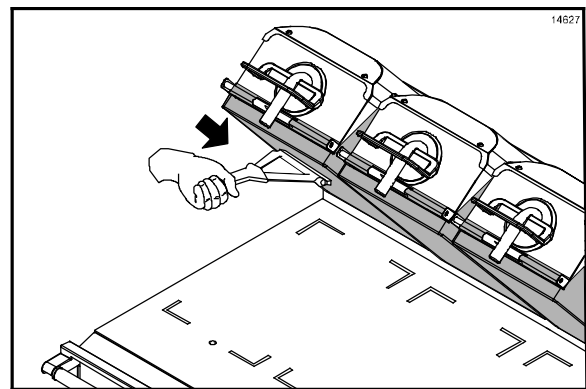

Figure 31

2. Use the wiper squeegee to clean the release material sheet on the upper platen. Use a diagonal motion to clean the sheet. Hold the handle at a slight upward angle, with the wiper end facing downward. (See Figure 32.)



Note: Do not use excessive pressure when wiping the release sheet. Using excessive pressure can scratch or tear the release sheet.

Figure 32

- Using the wiper squeegee, push the grease at the rear of the lower grill plate into the grease can. **Do not** use the grill scraper for this step. (See Figure 33.)

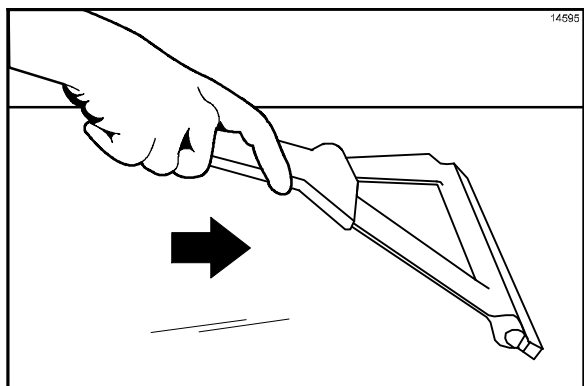

Figure 33





- Use the grill cloth to clean the back splash plate and the bullnose areas as needed during operation.

Note: To increase the life of the release material sheet, wipe it with a damp, folded grill cloth a minimum of **four times** every hour.



CAUTION: THE UPPER PLATEN SURFACE IS VERY HOT! TO PREVENT BURN INJURIES, USE EXTREME CAUTION WHEN WIPING THE RELEASE MATERIAL SHEET.

To Cook in the Flat Grill Mode

- To select a flat grill menu item, press the  key.
- Press the  key for the Manual Mode. Scroll to the desired flat menu item by pressing the  or  keys. The display may show “TOO COOL” or “TOO HOT”, until the grill reaches the set temperatures.
- After placing product in the prescribed method, press the STANDBY button to start the cook cycle. (See Figure 34.)

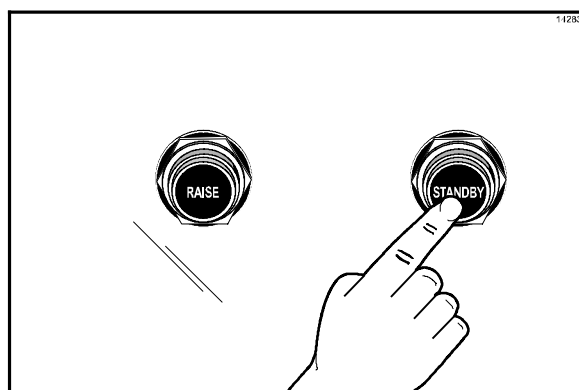



Figure 34

- Perform the functions that appear on the display (i.e., sear, turn). (**Note:** Pressing the RAISE button will cancel the cook cycle.)
- When the cook cycle is complete, the display will flash the message “REMOVE” and an audible alert will sound. Remove the product, per the prescribed method.

To Transition From Breakfast to Lunch

1. If the grill is in the AM AUTO Mode, press the  key to select PM.
2. If the grill is set to a certain breakfast item in the Manual Mode, press the  key to select PM.
3. The display may show “TOO COOL” or “TOO HOT”, until the grill reaches the set temperatures.

To Display the Current Temperatures



Note: The actual temperatures may be displayed at any time, including during a cook cycle.

1. Press the  key. A series of screens will display. The first screen will display as follows.

Top Bck	(AM/PM)	Top Frt
Back	Cntr	Frt

2. The next display will show the actual temperatures, per the following example.

426	Now/Deg F	425
348	350	349







Note: Pressing the  key once and the  key five times will keep the temperatures on the screen until the  key is pressed.

3. The next display will show the set point temperatures, per the following example.

425	Set/Deg F	425
350	350	350

4. The display will then return to the selected menu item.

To Change Product Cook Times

1. Press the  key to put the grill into the Manual Mode.
2. Scroll to the menu item that requires a change to the cook time by pressing the  or  keys.
3. Press and hold the  key for 3-5 seconds.
4. Use the  key to increase the time and the  key to decrease the time. Each press of the key changes the time by one second.
5. Press the  key to save the changes.

To Change a Menu Item

See “Product Selection” on page 17.

Probe Calibration

For grill markets that use lower release material sheets, probe calibration is performed with the release sheets installed. For grill markets that do not use lower release material sheets, probe calibration is performed without the upper release sheets installed.

Thermocouple probes are located from front to rear on the lower grill plates and upper platens. Measurements should be taken from front to back and left to right on all model grills.

See Figure 35 below, which identifies the probe locations.

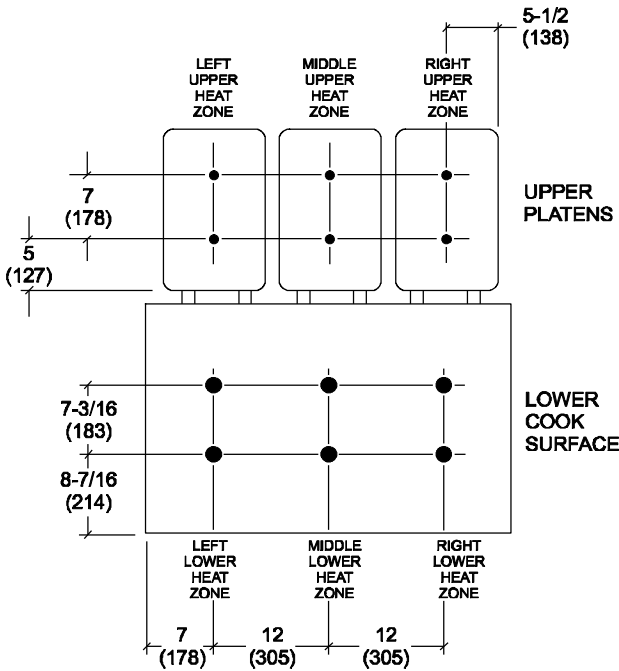







Figure 35

1. Press the  key to put the grill into the Manual Mode.
2. Press and hold the  key for three seconds.
3. Place a pyrometer surface probe on the selected heat zone as shown in Figure 35.
4. If the displayed temperature on the controller is more than 5°F/3°C different from the pyrometer surface probe display:

Press the  key to increase the temperature or press the  key to decrease the temperature to match the displayed temperatures.

Note: The set of numbers that follow the zone name represent the previous calibration adjustment.

5. To calibrate the next zone, use the  key to move to the next zone.
6. Once calibration is complete, press the  key to save all changes.

DAILY CLEANING PROCEDURES

Grills Using Lower Release Sheets

Note: This manual contains separate procedures for grills that use lower release sheets and for grills that do not use lower release sheets. Use the appropriate procedures for your grill.

If your grill does not use lower release sheets, go to page 33.



- **CAUTION:** Never use cold water or ice to cool the upper platen or the lower grill plate.
- Never use grill screens on the upper platen or the lower grill plate.
- Never allow the grill scraper or abrasive cleaning materials to come in contact with the release sheet.

1. Raise the upper platen to the OPEN position by pressing the red RAISE key. (See Figure 36.)

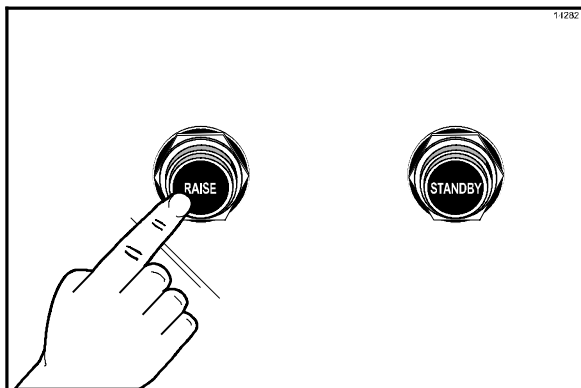



Figure 36



CAUTION: NEVER USE FORCE TO RAISE THE UPPER PLATEN. DAMAGE TO COMPONENTS MAY RESULT. USE ONLY THE RAISE KEY TO OPEN THE UPPER PLATEN!

2. Press the  key until the message “CLEANING” is displayed

3. Press the  key.

When the cook surfaces reach the proper temperature for cleaning, an alarm will sound and the message “READY TO CLEAN” will be displayed.

4. Press the  key to cancel the alarm.

5. Press the  key again and the message “OFF” will display.

6. Put on heat-resistant gloves. (See Figure 37.)

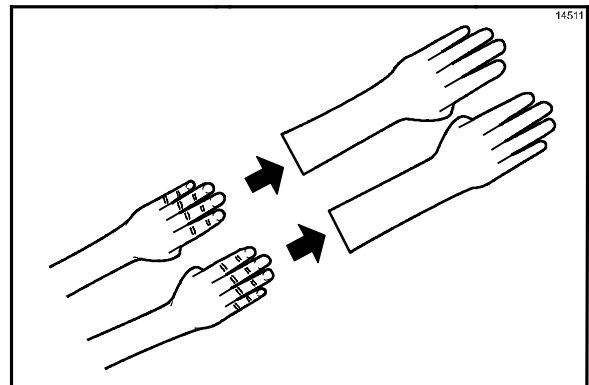

Figure 37

7. Remove, empty, and reinstall the grease pans. (See Figure 38.)

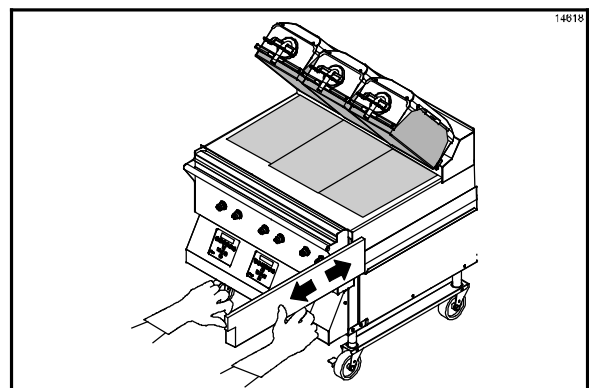

Figure 38



CAUTION: THE UPPER PLATENS, LOWER COOK SURFACE AND RELEASE SHEETS ARE VERY HOT. TO PREVENT BURN INJURIES, USE EXTREME CARE.

8. Wipe the exposed surface of the upper and lower release sheets with a clean, sanitizer-soaked grill cloth. (See Figure 39.)

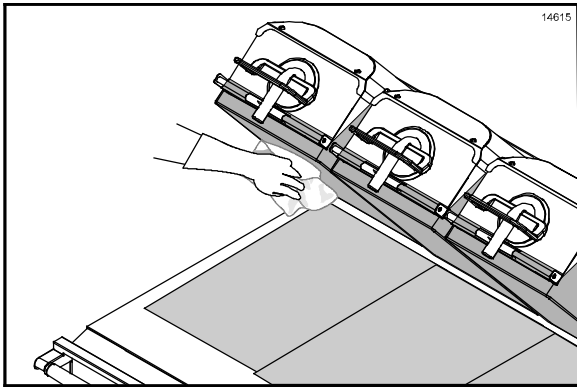

Figure 39

9. Open one packet of **McD Hi-Temp Grill Cleaner (HTGC)**. Empty the contents into a clean entrée base or stainless steel pan. (See Figure 40.)

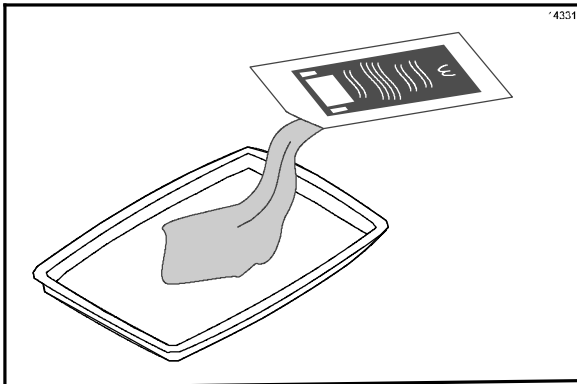

Figure 40

10. Dip a clean, sanitizer-soaked grill cloth into the grill cleaner. Do not saturate the cloth. (See Figure 41.)

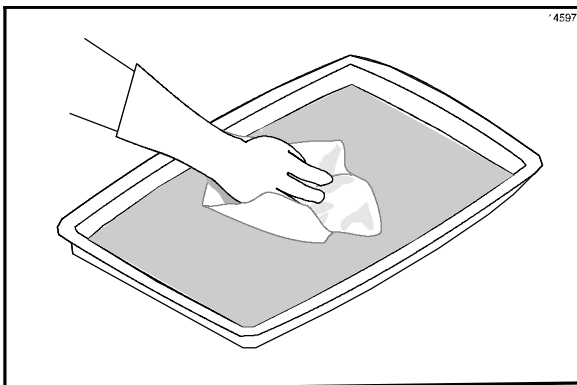

Figure 41

11. Use the grill cloth dampened with grill cleaner to clean the exposed surfaces of the upper and lower release sheets. (See Figure 42.)

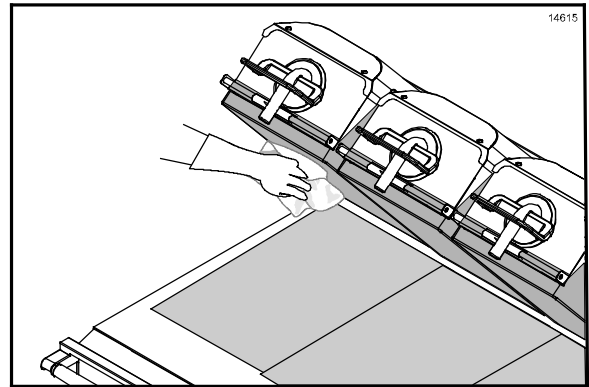

Figure 42

12. Remove the release sheet locking clips, the bars, and the upper and lower release sheets. Wash and rinse the clips and bars in the 3-compartment sink. If necessary, soak them in a hot solution of **SolidSense APSC** to remove carbon accumulation. (See Figure 43.)

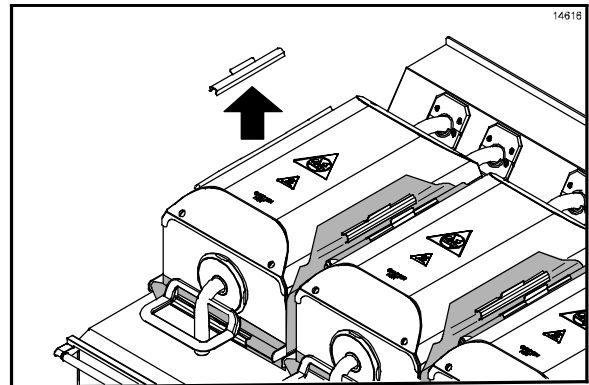

Figure 43

- Place all release sheets flat on the release sheet storage tray. DO NOT fold, crease, or place them on sharp objects. DO NOT clean them in the 3-compartment sink. (See Figure 44.)

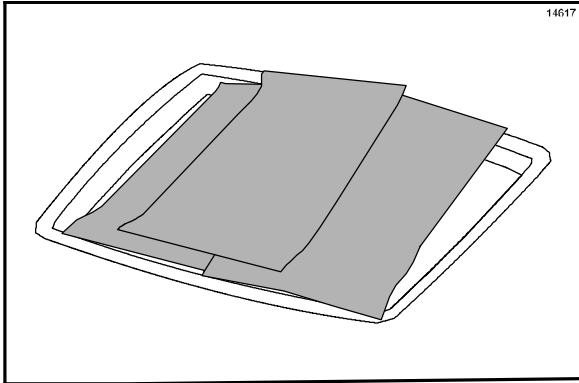

Figure 44

- Dip the Kay Grill Cleaning Pad Holder into the grill cleaner. (See Figure 45.)

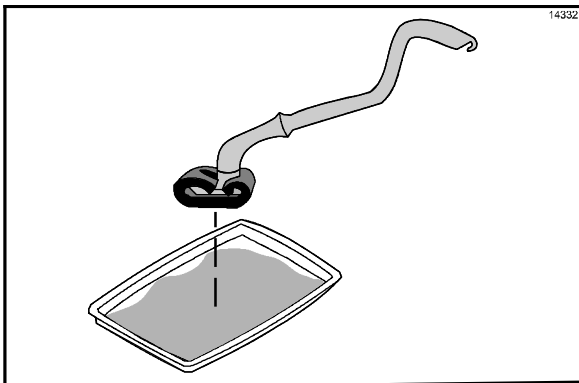

Figure 45

IMPORTANT: DO NOT scrub while applying grill cleaner in the following steps:

- Spread a light coating of the grill cleaner over the entire lower grill surface, using front to back strokes. Allow the product to remain on the grill while spreading across all surfaces. (See Figure 46.)

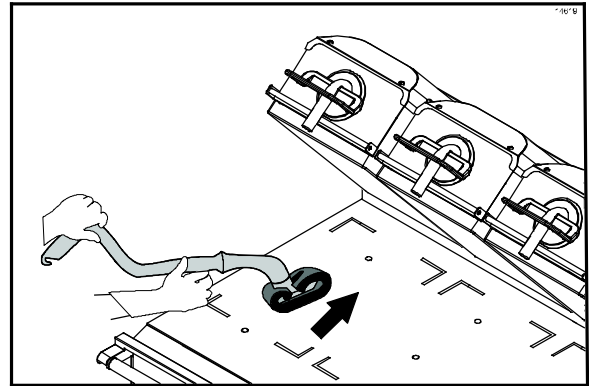

Figure 46

Note: Allowing the grill cleaner to sit on the grill surfaces will require less effort and time to scrub heavy soil buildup and achieve a clean grill.

- Apply **McD Hi-Temp Grill Cleaner (HTGC)** to the front side of the platens, starting from the right platen to the left platen. (See Figure 47.)

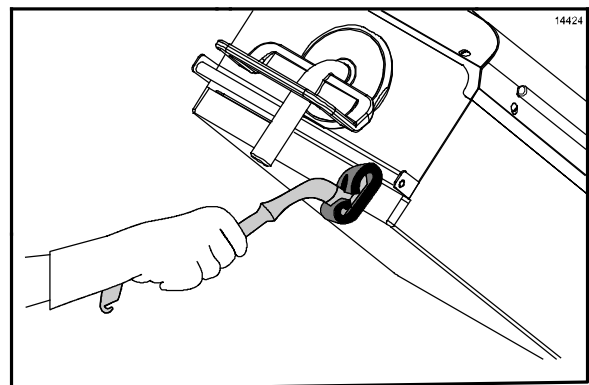

Figure 47

17. Apply the grill cleaner to the platen surfaces, starting from the right platen to the left platen. (See Figure 48.)

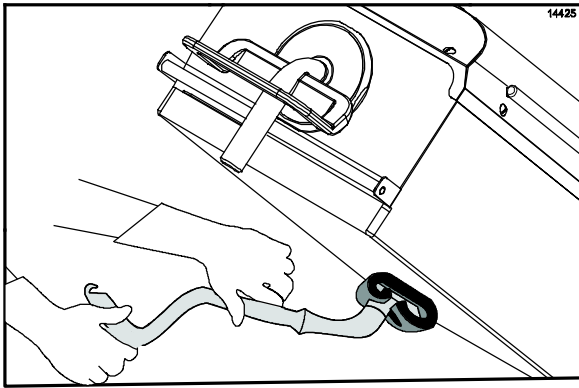

Figure 48

20. Press the black STANDBY button to lower the center platen. (See Figure 51.)

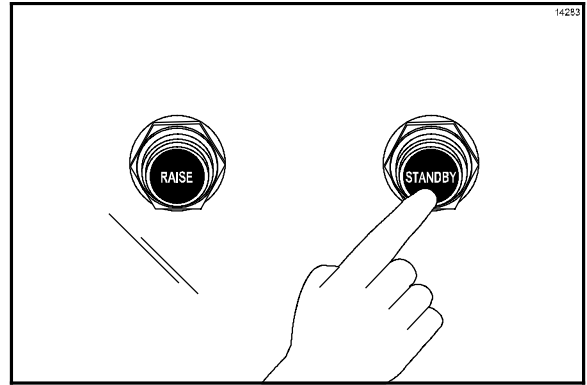

Figure 51

18. Apply the grill cleaner to the back side of the platens, from the right platen to the left platen. (See Figure 49.)

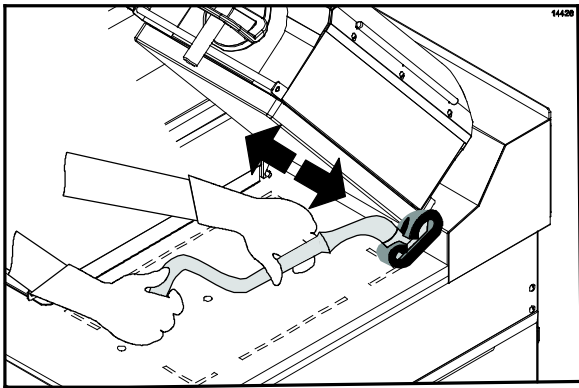

Figure 49

21. Apply the grill cleaner to both sides of the center platen. (See Figure 52.)

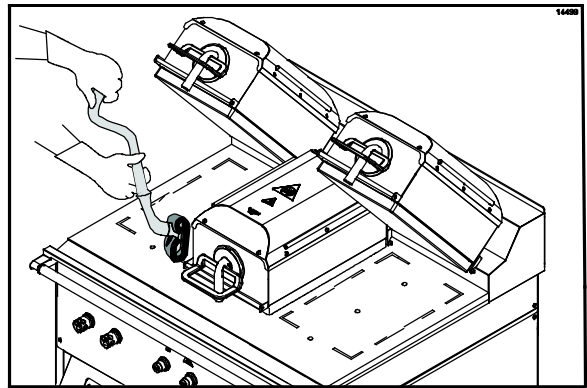

Figure 52

19. Apply the grill cleaner to the outer edges of the right and left platens. (See Figure 50.)

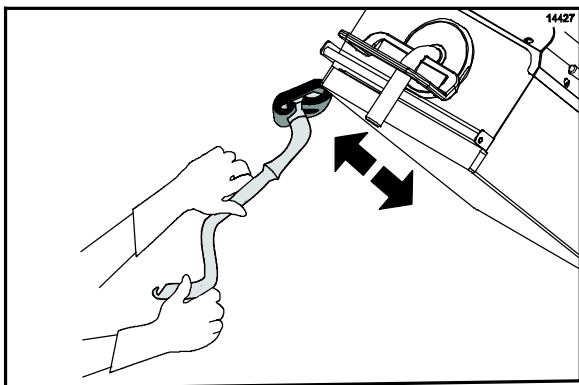

Figure 50

22. Apply grill cleaner to the inner edges of the right and left platens. (See Figure 53.)

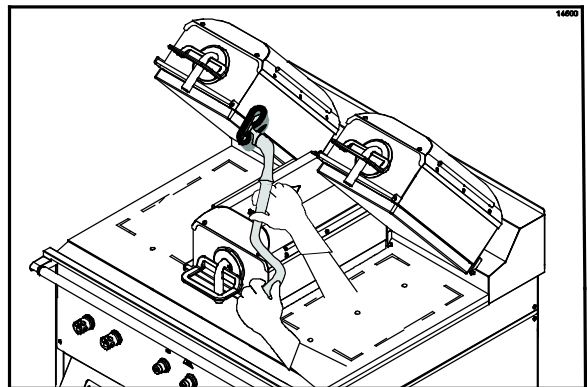

Figure 53

23. Press the red RAISE button to raise the center platen.
24. Using the Kay Grill Cleaning Pad Holder, scrub the front side of the platens from the right platen to the left platen. (See Figure 54.)

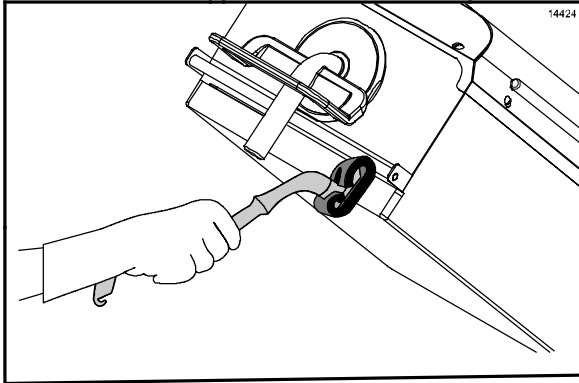

Figure 54

Note: Scrub all areas containing visible soil accumulation until the soil liquefies.

25. Scrub the platen surfaces, starting from the right platen to the left platen. (See Figure 55.)

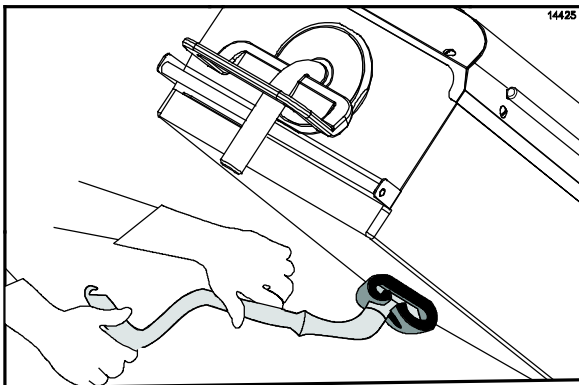

Figure 55

26. Scrub the back side of the platens from the right platen to the left platen. (See Figure 56.)

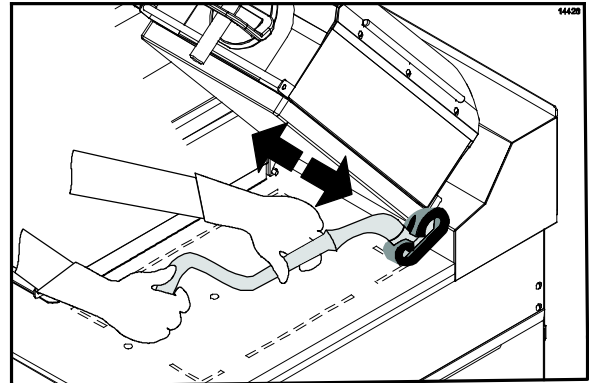

Figure 56

27. Scrub the outer edges of the right and left platens. (See Figure 57.)

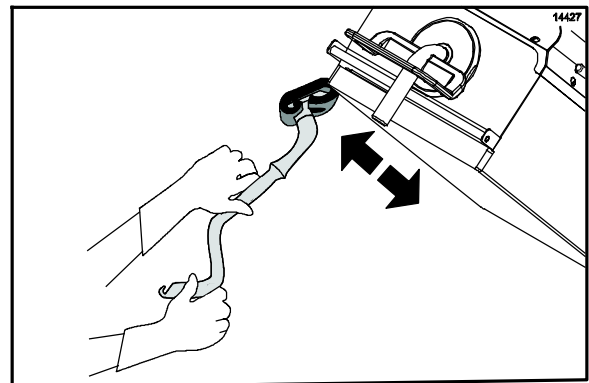

Figure 57

28. Press the black STANDBY button to lower the center platen.
29. Apply the grill cleaner to both sides of the center platen. (See Figure 58.)

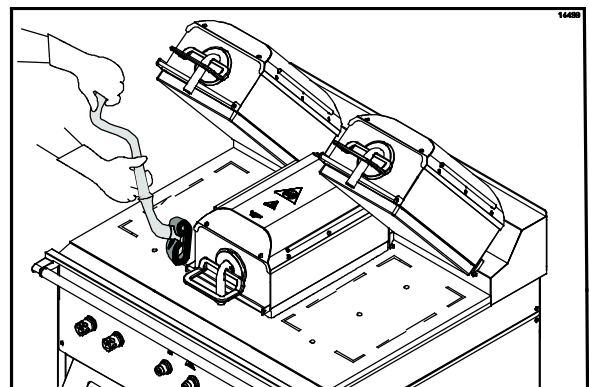

Figure 58

30. Scrub the inner edges of the right and left platens. (See Figure 59.)

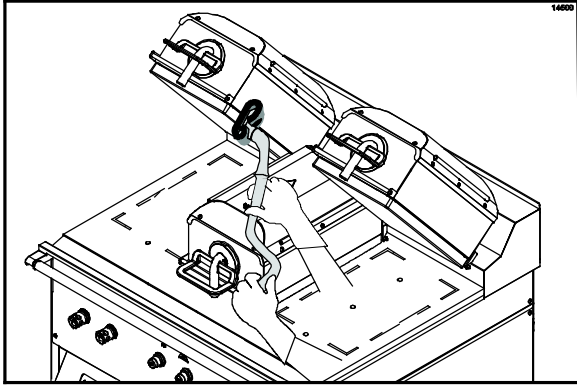

Figure 59

31. Press the red RAISE button to raise the center platen.
32. Rinse the front, side, and back of the platen surfaces with a clean, sanitizer-soaked grill cloth, starting from the right platen to the left platen. (See Figure 60.)

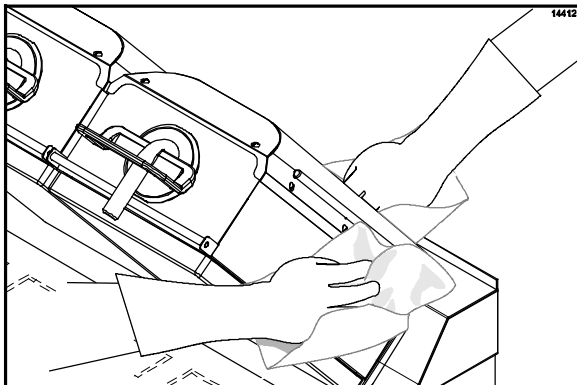

Figure 60

33. Press the black STANDBY button to lower the center platen.
34. Rinse both sides of the center platen. (See Figure 61.)

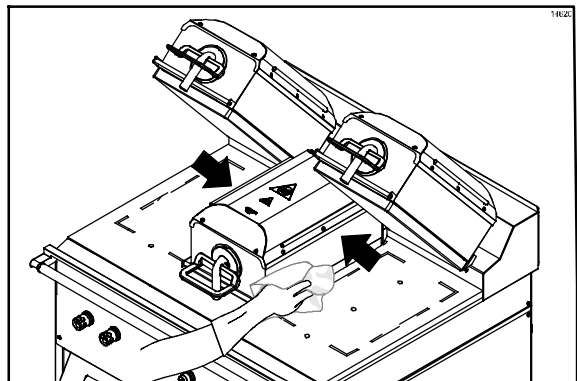

Figure 61

35. Rinse the inner edges of the right and left platens with a clean, sanitizer-soaked grill cloth. (See Figure 62.)

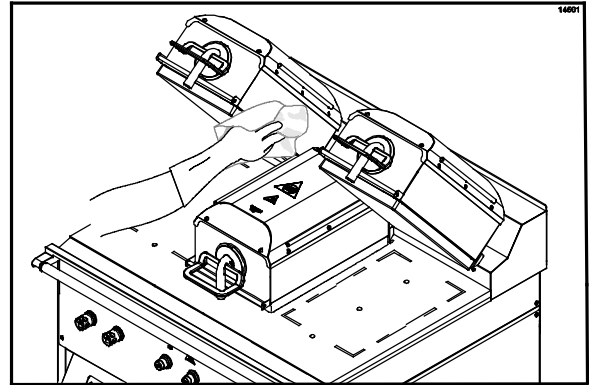

Figure 62

36. Press the red RAISE button to raise the center platen.
37. Rinse the lower grill surface with a clean, sanitizer-soaked grill cloth. (See Figure 63.)

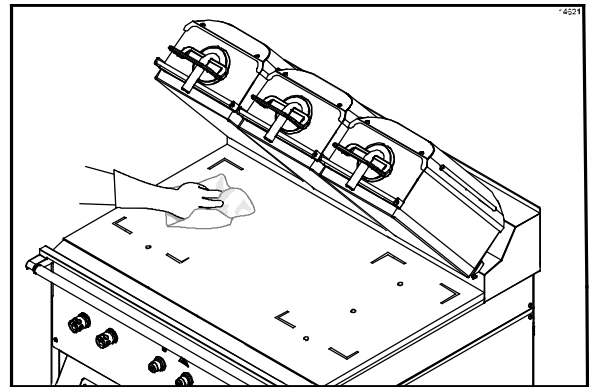

Figure 63

38. Clean the surrounding areas such as the hood, bull nose, and back splash, with a clean, sanitizer-soaked grill cloth. (See Figure 64.)

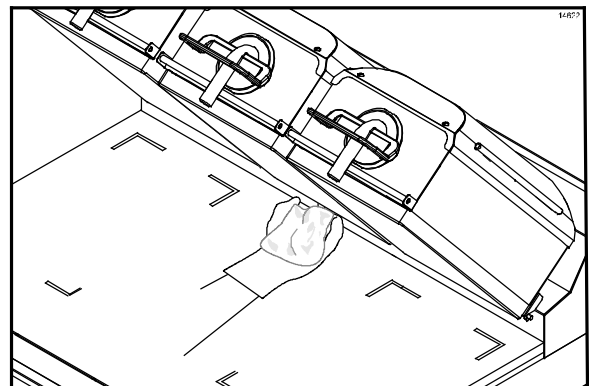

Figure 64

Note: The rear of the upper platen, as well as the tubular arm, can easily be

wiped from the front of the unit. If cleaning is performed on a daily basis, there should be no carbon build-up.

- 39. One at a time, place the upper and lower release sheets on the lower grill surface. Wipe both sides of each release sheet with a clean, sanitizer-soaked grill cloth. (See Figure 65.)

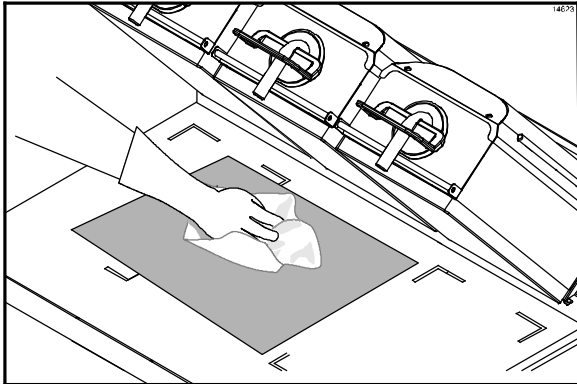

Figure 65

- 40. Re-install the upper release sheets. Secure the sheets with the locking clips and bars. (See Figure 66.)

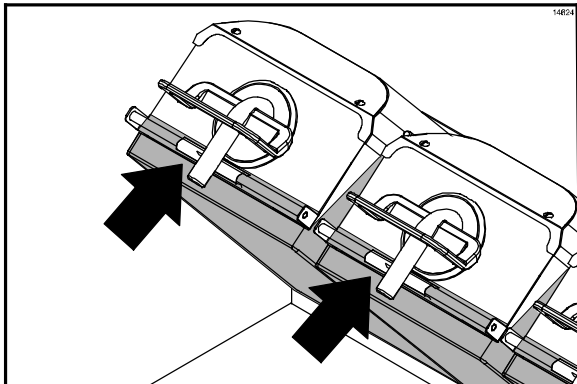

Figure 66

Note: Reverse the cooking side of the release sheets on a daily basis (example: black side on odd days; grey or brown side on even days).

- 41. Wipe the lower grill surface with a clean, sanitizer-soaked grill cloth. Repeat until surface is clean. (See Figure 67.)

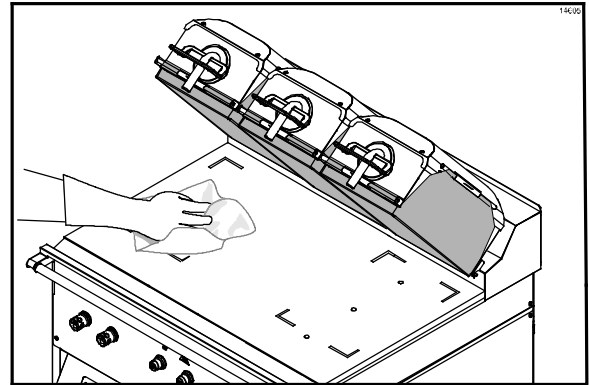

Figure 67

- 42. Remove and empty the grease pans. (See Figure 68.)

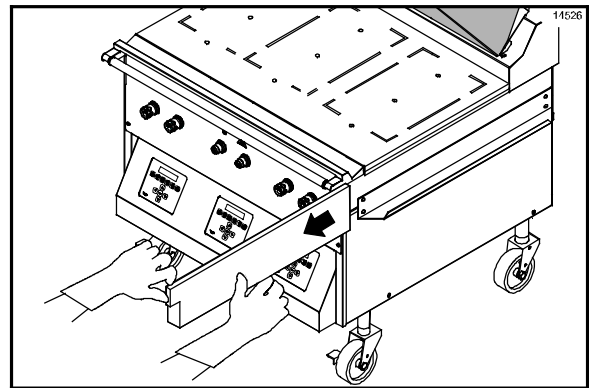

Figure 68

- 43. Wash and rinse the grease pans in the 3-compartment sink.
- 44. Re-install the grease pans. (See Figure 69.)

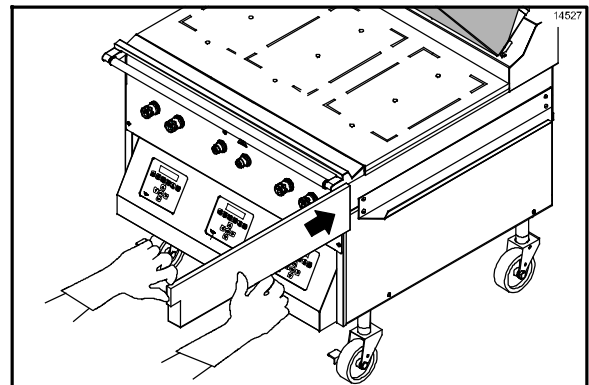



Figure 69

45. Press the  key for 3 - 5 seconds. "AM TOO COOL" and "AM FOLDED EGGS - CLAM" will be displayed on the control screen.
46. The screen will then display, "CLEAN GRILL SURFACES," followed by "CLOSE PLATEN FOR AUTO LEVELING."
47. Using a sundae spoon, distribute two level spoonfuls of soy adhesion flakes over a warm 3 ft. (1 m.) lower grill surface, allowing the flakes to melt. (See Figure 70.)

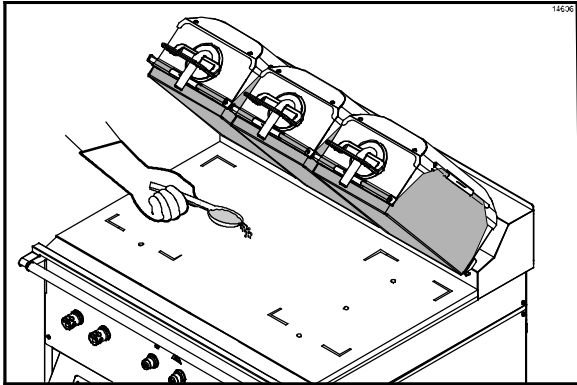

Figure 70

48. Using a clean squeegee, spread the flakes on the cooking zone. (See Figure 71.)

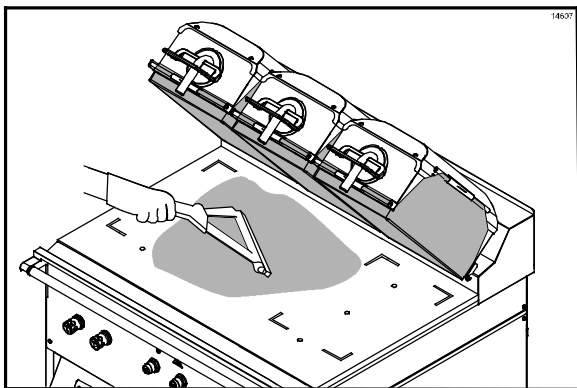

Figure 71

49. With the narrow side of the lower release sheet facing the back of the grill, hold the release sheet about one inch from the end of each side. Align the back edge of the release sheet with the back splash and the side edge of the grill. (See Figure 72.)

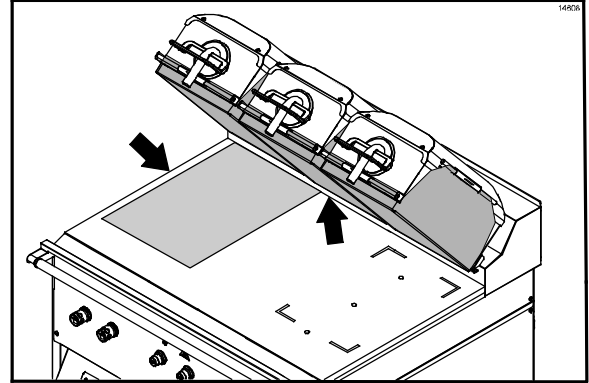

Figure 72

50. Using the grill squeegee, gently squeegee out air bubbles, making sure not to crease or fold the release sheet. (See Figure 73.)

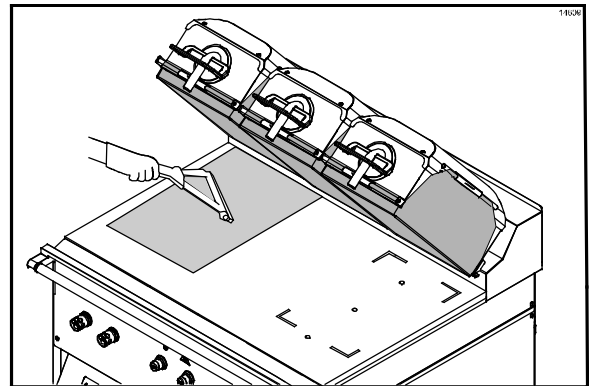

Figure 73

51. Repeat the last two steps for the release sheet on the other side of the grill. (See Figure 74.)

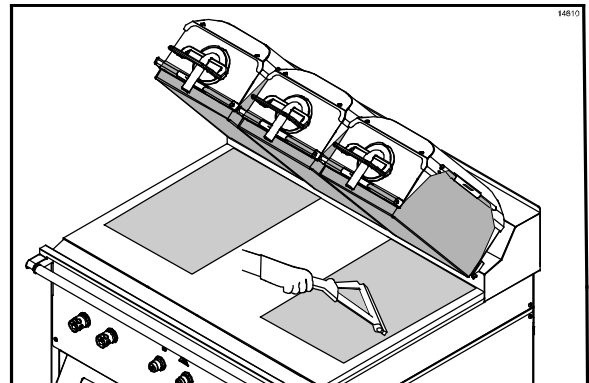

Figure 74

- Align the back edge of the third lower release sheet with the back splash and middle of the grill. The release sheet will overlap the edge of the other two release sheets. (See Figure 75.)

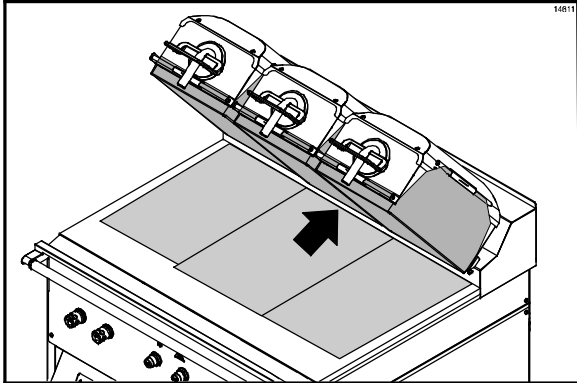

Figure 75

- Use the squeegee to gently remove the air bubbles.

Note: When properly applied, the release sheets will lay flat, with only a few small air bubbles.

- Leave the upper platens in the OPEN position overnight.
- Place the fan interlock switch in the OFF position. (See Figure 76.)

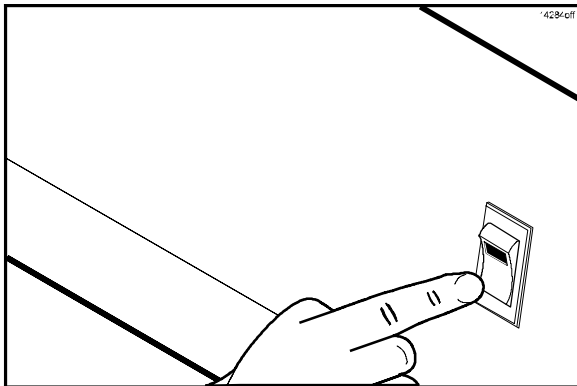

Figure 76

- After the grill cleaning pad has cooled, remove it from the pad holder. Wash and rinse it thoroughly at the 3-compartment sink. Turn the grill pad over and re-install it on the holder.
- Wash, rinse, and sanitize all utensils and tools used to clean the grill at the 3-compartment sink.

Cleaning Procedure - 24 Hour Stores Only (Grills Using Lower Release Sheets)

- Clean the grill using the Daily Cleaning Procedures on pages 24 - 32, steps 1 - 53.
- After the grill pad has cooled, remove, wash, and rinse it thoroughly at the 3-compartment sink. Turn the grill pad over and re-install on the grill pad holder.
- Wash, rinse, and sanitize all utensils and tools used to clean the grill at the 3-compartment sink.
- Place the fan interlock switch in the OFF position. Wait 10 seconds and then place the switch back in the ON position. The display will read "OFF".
- Press the Standby button to close the platen.
- After the platen has closed, the control will display "GRILL TOO COOL FOR AUTO LEVELING" until the grill reaches the proper temperature. When the proper temperature is reached, the platen will self-level and open when completed. The grill will be in the AM Manual mode.
- The grill is now ready to use.

DAILY CLEANING PROCEDURES

Grills Not Using Lower Release Sheets

IMPORTANT: This manual contains separate procedures for grills that use lower release sheets and for grills that do not use lower release sheets. Use the procedures appropriate for your grill.

If your grill uses lower release sheets, use the instructions starting on page 24. Failure to follow this instruction will result in equipment damage and poor grill performance.



- **CAUTION: Never use cold water or ice to cool the upper platen or the lower grill plate.**
- **Never use grill screens on the upper platen or the lower grill plate.**
- **Never allow the grill scraper or abrasive cleaning materials to come in contact with the release sheet.**

1. Raise the upper platen to the OPEN position by pressing the red RAISE button. (See Figure 77.)

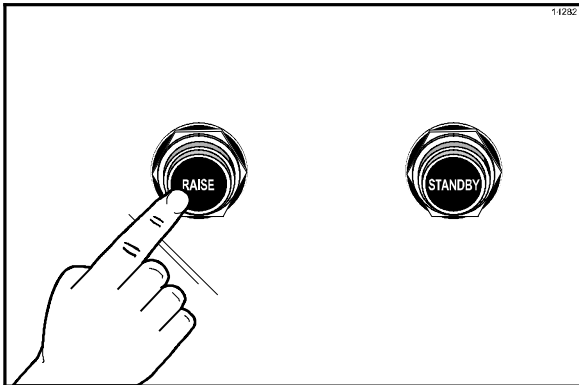

Figure 77



CAUTION: NEVER USE FORCE TO RAISE THE UPPER PLATEN. DAMAGE TO COMPONENTS MAY RESULT. ONLY USE THE RAISE KEY TO OPEN THE UPPER PLATEN!

2. Press the  key until the message “CLEANING” is displayed.

3. Press the  key.

When the cook surfaces reach the proper temperature for cleaning, an alarm will sound and the message “READY TO CLEAN” will be displayed.

4. Press the  key to cancel the alarm.

5. Press the  key again and the message “OFF” will display.

6. Put on heat-resistant gloves. (See Figure 78.)

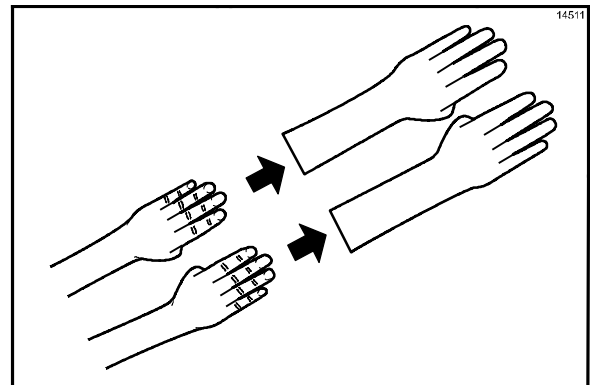

Figure 78



CAUTION: THE UPPER PLATEN SURFACE AND RELEASE MATERIAL SHEETS ARE VERY HOT. TO PREVENT BURN INJURIES, USE EXTREME CARE.

7. Wipe the exposed surface of the release sheets with a clean, sanitizer-soaked grill cloth. (See Figure 79.)

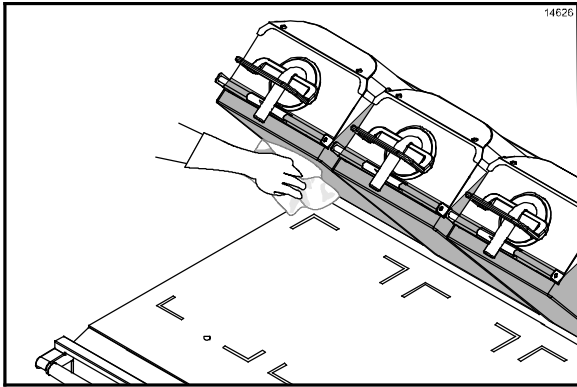

Figure 79

8. Remove the release sheet locking clips, bars, and release sheets. Take the clips and bars to the 3-compartment sink to be washed and rinsed. If necessary, soak them in a hot solution of **SolidSense APSC** to remove carbon accumulation. (See Figure 80.)

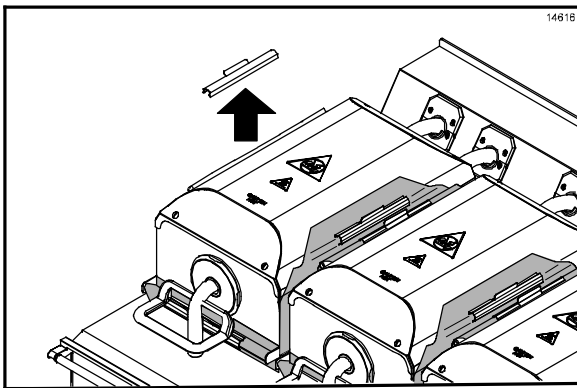

Figure 80

9. Set the release sheets aside on a clean, flat surface until further cleaning is performed. **Do not** fold, crease, or place them on sharp objects. (See Figure 81.)

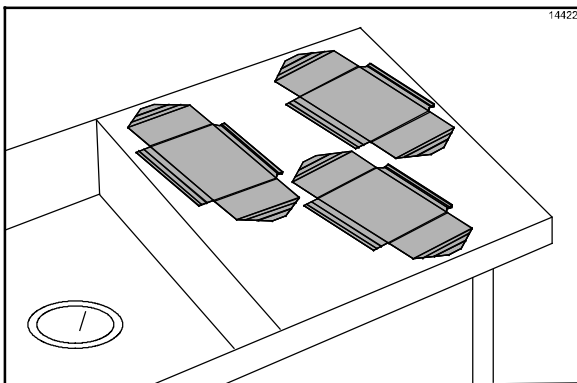

Figure 81

10. Scrape the **lower** grill surface with the grill scraper, from front to back. (See Figure 82.)

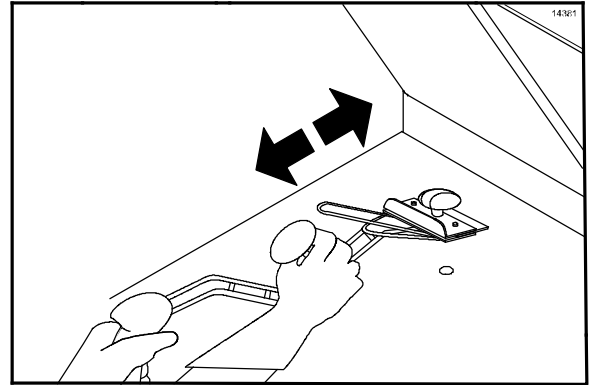

Figure 82

11. Use the grill squeegee to push residual grease into the grease pans. (See Figure 83.)

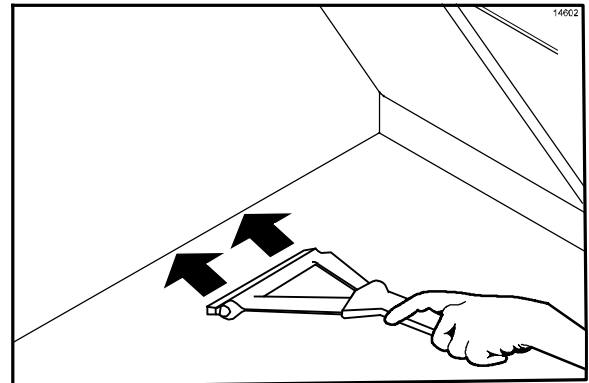

Figure 83

12. Remove, empty, and reinstall the grease pans. (See Figure 84.)

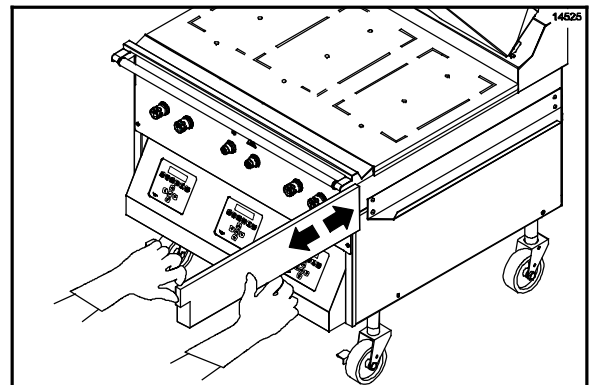

Figure 84

13. Open one packet of **McD Hi-Temp Grill Cleaner (HTGC)**. Empty the contents into an entrée base or stainless steel pan. (See Figure 85.)

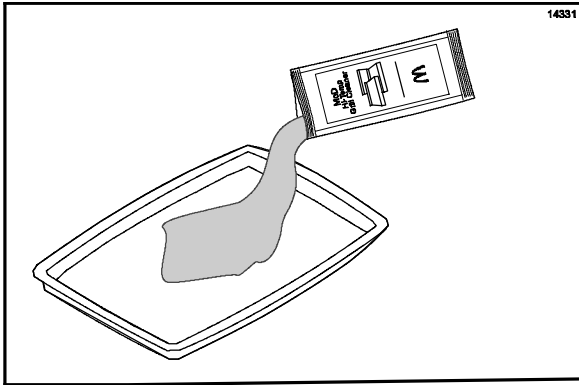

Figure 85

14. Dip the Kay Grill Cleaning Pad Holder into the grill cleaner. (See Figure 86.)

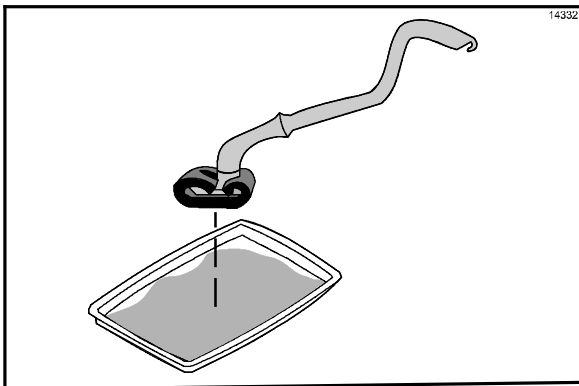

Figure 86

IMPORTANT: DO NOT scrub while applying the grill cleaner in the following steps:

15. Apply **McD Hi-Temp Grill Cleaner (HTGC)** to the front side of the platens, starting from the right platen to the left platen. (See Figure 87.)

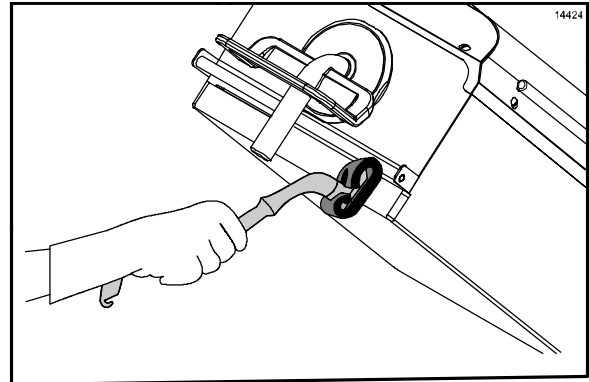

Figure 87

! DO NOT USE METAL SCRAPERS, ABRASIVE PADS, SCREENS OR WIRE BRUSHES ON THE UPPER PLATENS. DAMAGE TO COMPONENTS MAY RESULT.

16. Apply the grill cleaner to the platen surfaces, starting from the right platen to the left platen. (See Figure 88.)

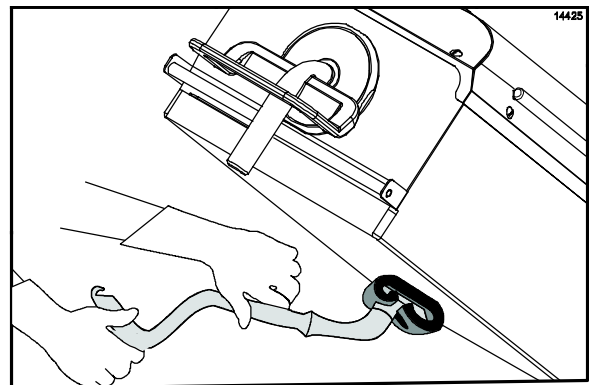

Figure 88

- Apply the grill cleaner to the back side of the platens, from the right platen to the left platen. (See Figure 89.)

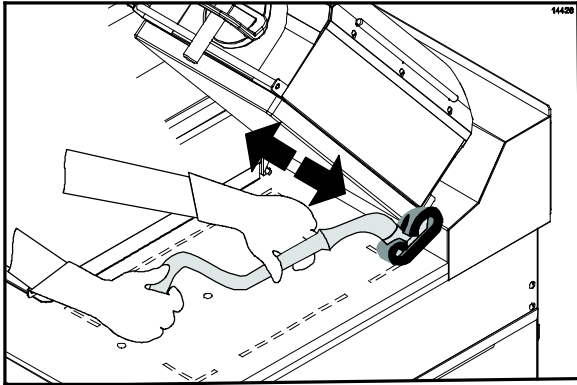

Figure 89

- Apply the grill cleaner to the outer edges of the right and left platens. (See Figure 90.)

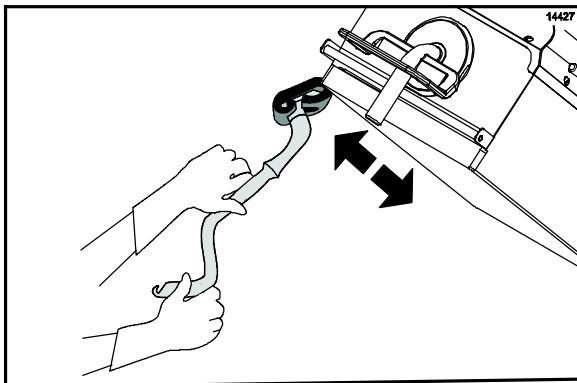

Figure 90

- Press the black STANDBY button to lower the center platen. (See Figure 91.)

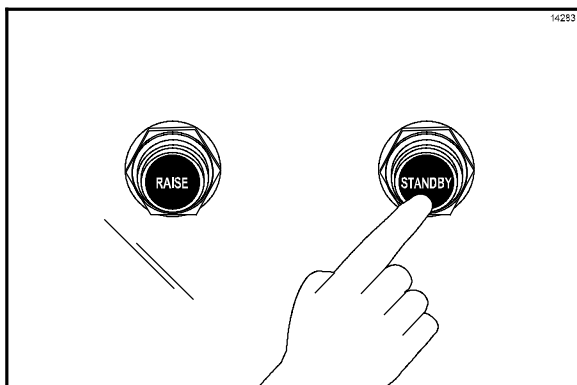

Figure 91

- Apply the grill cleaner to both sides of the center platen. (See Figure 92.)

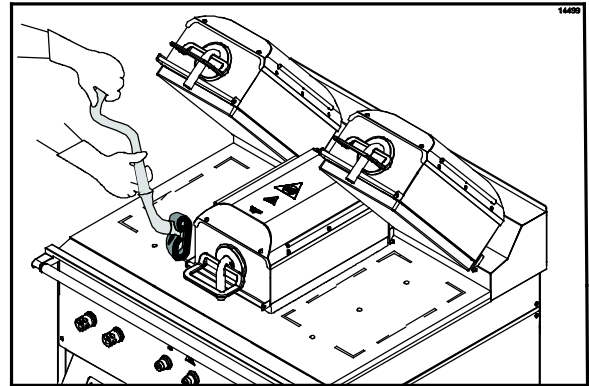

Figure 92

- Apply grill cleaner to the inner edges of the right and left platens. (See Figure 93.)

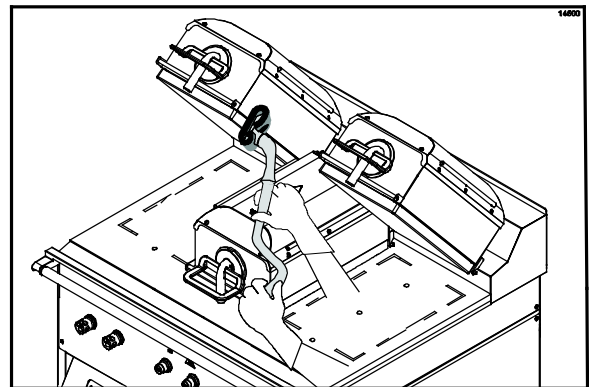

Figure 93

- Press the red RAISE button to raise the center platen.

- Using the Kay Grill Cleaning Pad Holder, scrub the front side of the platens from the right platen to the left platen. (See Figure 94.)

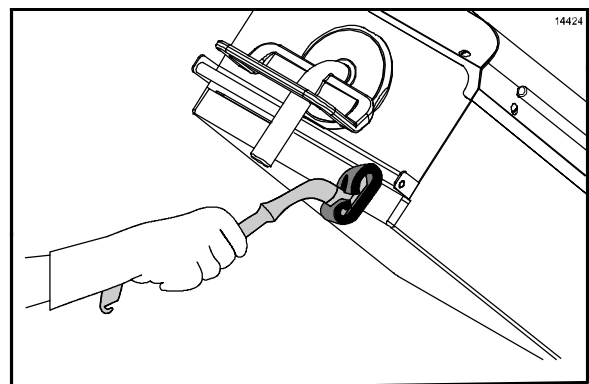

Figure 94

24. Scrub the platen surfaces, starting from the right platen to the left platen.
(See Figure 95.)

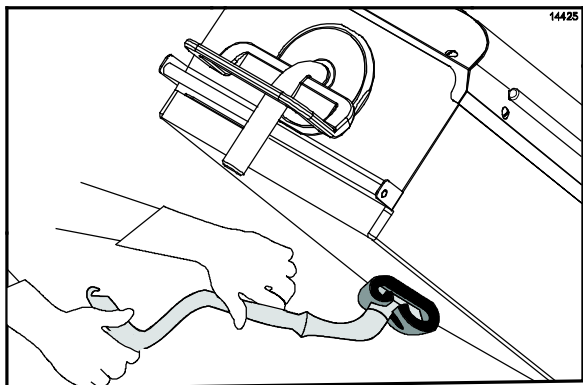

Figure 95

25. Scrub the back side of the platens from the right platen to the left platen.
(See Figure 96.)

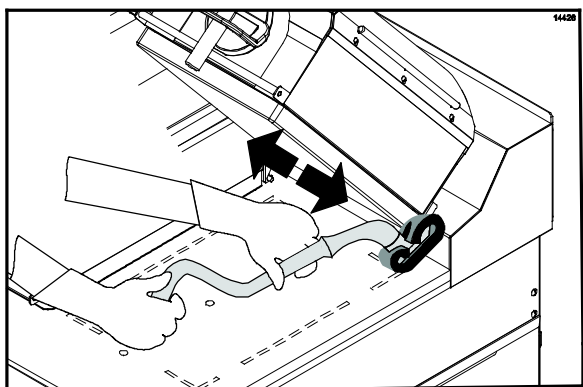

Figure 96

26. Scrub the outer edges of the right and left platens.
(See Figure 97.)

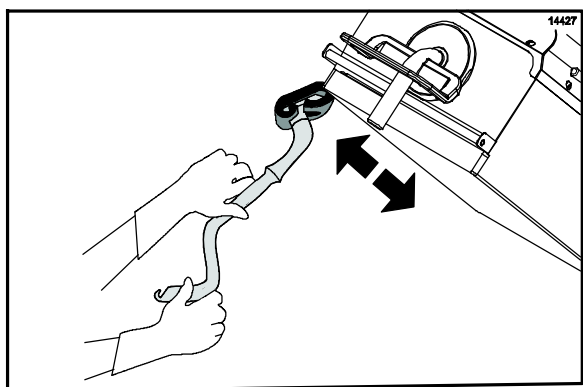

Figure 97

27. Press the black STANDBY button to lower the center platen.

28. Scrub both sides of the center platen.
(See Figure 98.)

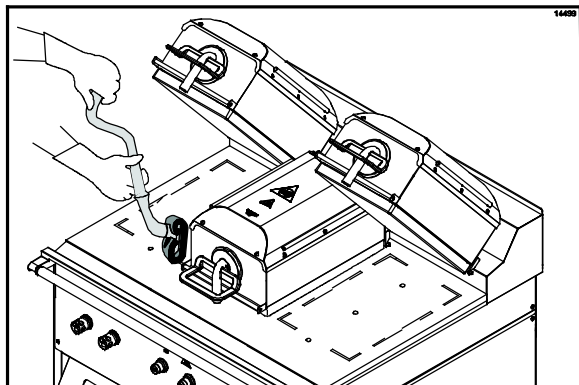

Figure 98

29. Scrub the inner edges of the right and left platens.
(See Figure 99.)

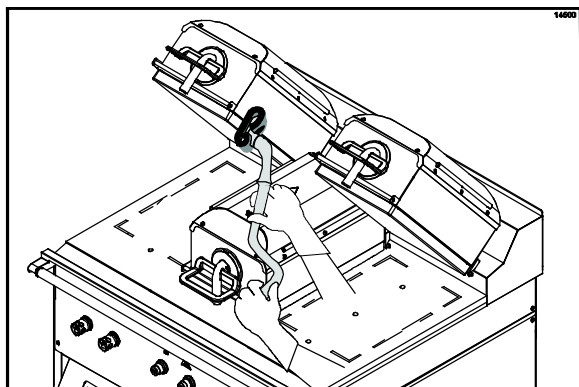

Figure 99

30. Press the red RAISE button to raise the center platen.

31. Rinse the front, side, and back of the platen surfaces with a clean, sanitizer-soaked grill cloth, starting from the right platen to the left platen. (See Figure 100.)

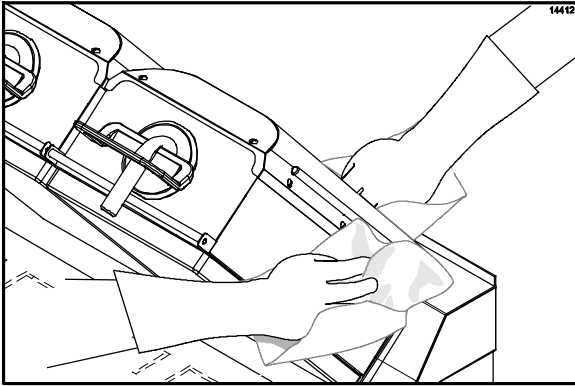

Figure 100

32. Press the black STANDBY button to lower the center platen.
33. Rinse both sides of the center platen. (See Figure 101.)

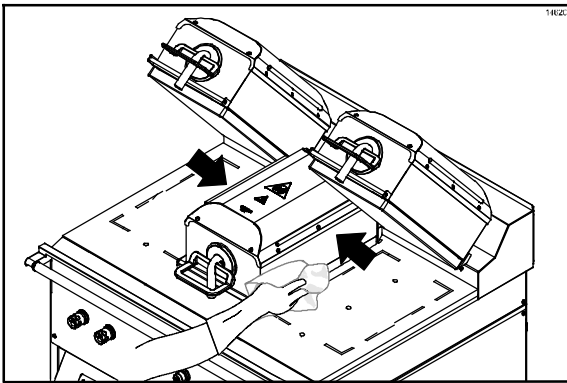

Figure 101

34. Rinse the inner edges of the right and left platens with a clean, sanitizer-soaked grill cloth. (See Figure 102.)

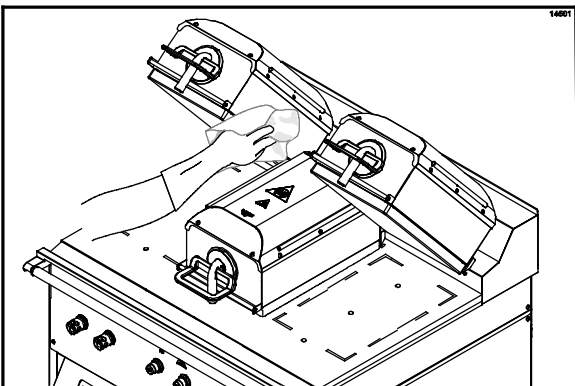

Figure 102

35. Press the red RAISE button to raise the center platen.
36. Wipe the back of the upper grill platen with a clean, sanitizer-soaked grill cloth.
37. Pour the remaining **McD Hi-Temp Grill Cleaner (HTGC)** onto the lower grill surface. (See Figure 103.)

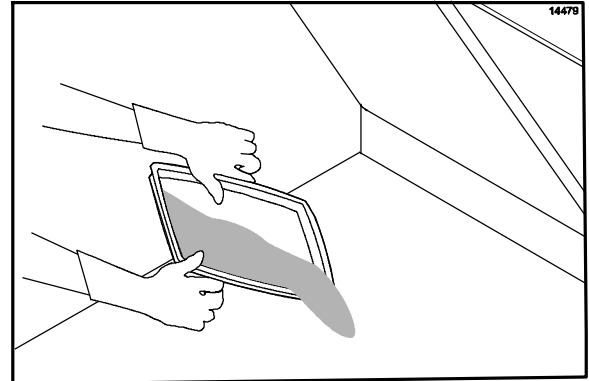

Figure 103

38. Spread the grill cleaner over the entire lower grill surface from front to back, using even strokes. **Do not scrub while applying product.** (See Figure 104.)

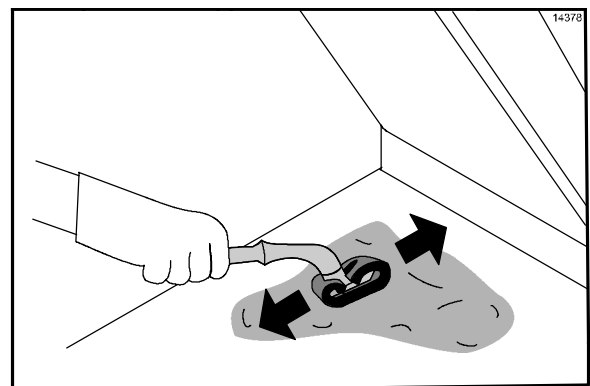

Figure 104

39. Use the cleaning pad holder to lightly scrub the lower grill surfaces until all soil has been liquified by the grill cleaner. For stubborn soils, apply additional grill cleaner and lightly scrub. (See Figure 105.)

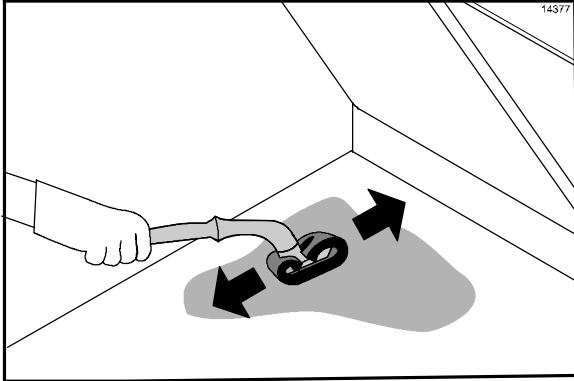

Figure 105

Note: The rear of the upper platen, as well as the tubular arm, can easily be wiped from the front of the unit. If cleaning is performed on a daily basis, there should be no carbon build-up.

40. Pour a small amount of lukewarm water on a clean, sanitizer-soaked grill cloth held over the bottom grill surface and wipe off the residue. (See Figure 106.)

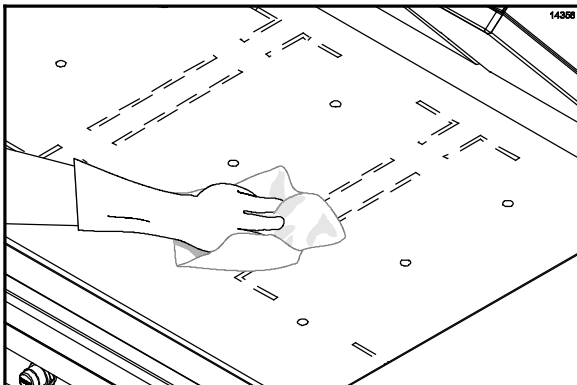

Figure 106

41. Place the upper platen release sheets flat on the lower grill surface. Gently clean both sides of the sheets with the Kay Grill Cleaning Pad Holder. (See Figure 107.)

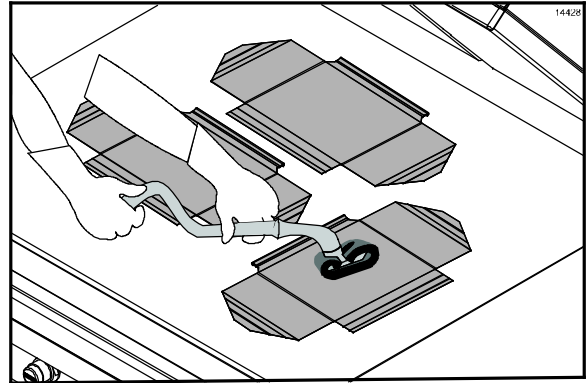

Figure 107

42. Rinse both sides of the release sheets with a clean, sanitizer-soaked grill cloth. (See Figure 108.)

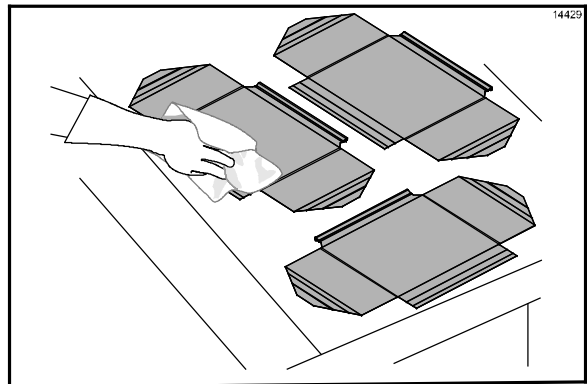

Figure 108

43. Re-install the release sheets on the opposite side than previously used. Secure the sheets with the locking clips and bars. (See Figure 109.)

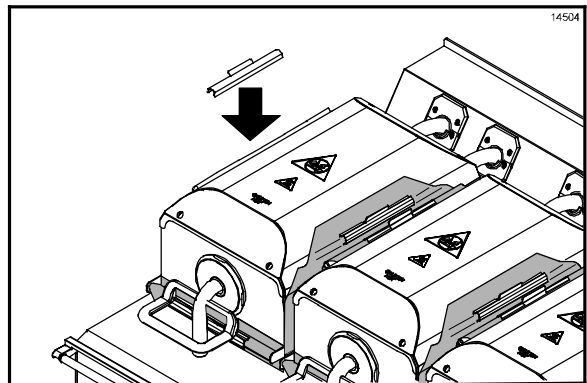

Figure 109

44. Wipe the lower grill surface with a clean, sanitizer-soaked grill cloth. Repeat, until no visible soil remains. (See Figure 110.)

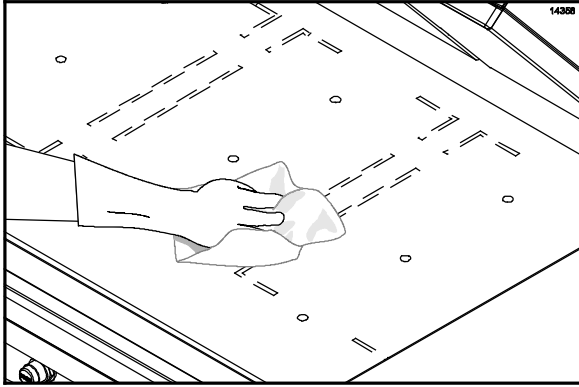

Figure 110

45. Remove and empty the grease pans. (See Figure 111.)

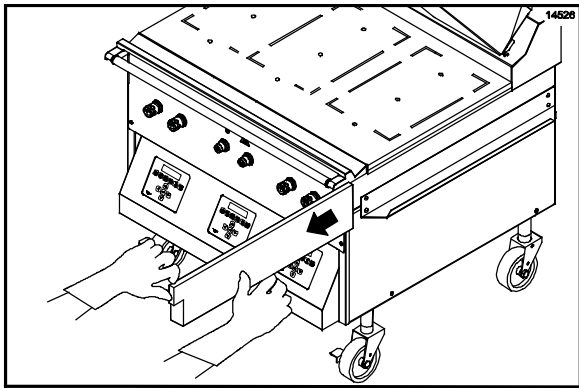

Figure 111

46. Wash and rinse the grease pans in the 3-compartment sink.

47. Re-install the grease pans. (See Figure 112.)

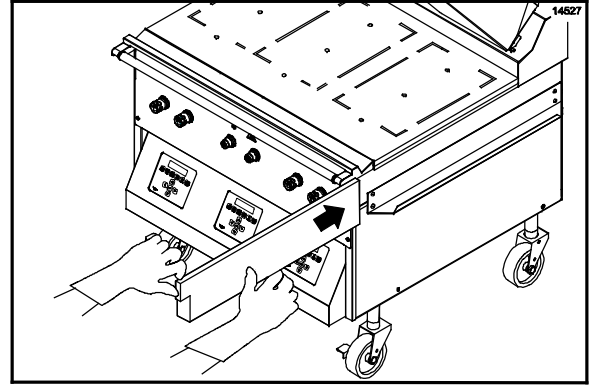

Figure 112

48. Wipe the remaining grill surfaces with a clean, sanitizer-soaked grill cloth.
49. Apply a light coat of fryer cooking oil to the entire **lower** grill surface, only.
50. Leave the upper platens in the OPEN position overnight.
51. Place the fan interlock switch in the OFF position. (See Figure 113.)

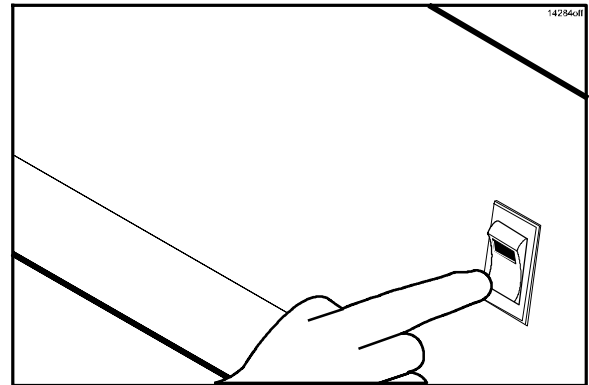





Figure 113

Cleaning Procedure - 24 Hour Stores Only (Grills Not Using Lower Release Sheets)

1. Press the  key until the message "CLEANING" is displayed. Press the  key."/>
 2. The grill controller will display "GRILL TOO HOT FOR CLEANING" until the grill reaches the proper temperature for cleaning. When the proper temperature is reached, a tone will sound and the control will display "GRILL READY FOR CLEANING".
 3. Press the  key to cancel the alarm.
 4. Press the  key again and the message "OFF" will display.
 5. Clean the grill using the Closing Procedures starting on page 33.
 6. After the grill has been cleaned, place the fan interlock switch in the OFF position. Wait 10 seconds and then place the switch back in the ON position. The display will read "OFF".
 7. Reinstall the release sheets. (See Figure 114.)

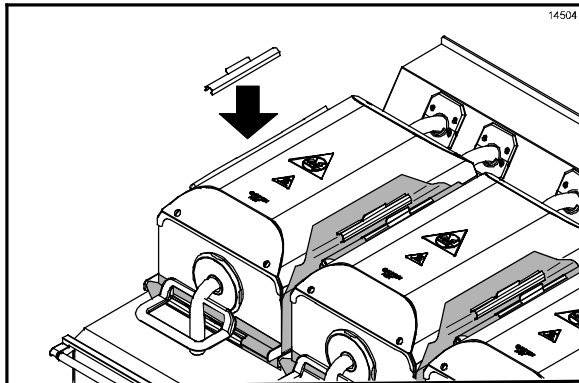



Figure 114

8. Press the  key for 3 - 5 seconds. "AM TOO COOL" and "AM FOLDED EGGS - FLAT" will be displayed on the control screen.
9. The screen will then display, "CLEAN GRILL SURFACES," followed by "CLOSE PLATEN FOR AUTO LEVELING."
10. Press the Standby button to close the platen. (See Figure 115.)

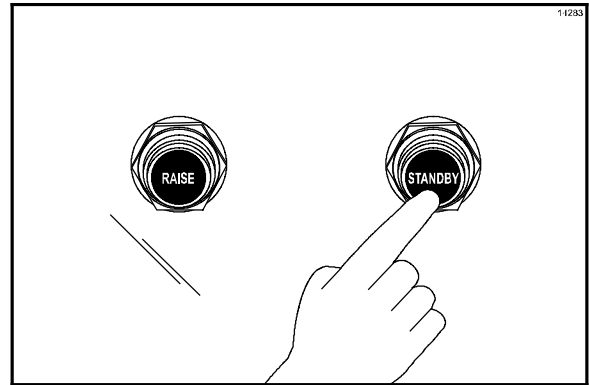

Figure 115

11. After the platen has closed, the control will display "GRILL TOO COOL FOR AUTO LEVELING" until the grill reaches the proper temperature. When the proper temperature is reached, the platen will self-level and open when completed. The grill will be in the AM Manual mode.
12. The grill is now ready to use.

TROUBLESHOOTING GUIDE



WARNING: Inspection, testing and repair of electrical equipment should be performed only by qualified service personnel.



DANGER: Use extreme care during electrical circuit tests. Live circuitry may be exposed.



The grill should be disconnected from all electricity when servicing, except when electrical tests are required.



The grill must be pulled away from the wall for thorough cleaning. When returning the grill to its original position, use extreme caution to smoothly and slowly roll the grill backward into place. Failure to do so may cause the grill to tip and can cause severe equipment damage or personal injury.

PROBLEM	PROBABLE CAUSE	REMEDY
The center heat zones and the heat zones on one side will not heat. The control displays "PROBE FAILURE."	One power connection is not connected.	Check the power connection.
	The restaurant circuit breaker has tripped.	Reset the restaurant circuit breaker.
	The contactor is faulty.	Call a service technician.
	The heater element is faulty.	Call a service technician.
	The high limit switch is faulty.	Call a service technician.
	The solid state relay is faulty.	Call a service technician.
The center heat zones and the heat zones on one side will not heat. The control displays "PROBE OPEN."	The thermocouple is faulty.	Call a service technician.
	The motor control board is faulty.	Call a service technician.
One heat zone will not heat. (Note: Affects only one specific heat zone.)	The interface board is faulty.	Call a service technician.
	The solid state relay is faulty.	Call a service technician.
	The control harness is faulty.	Call a service technician.
	The heater element is faulty.	Call a service technician.
	The high limit switch is faulty.	Call a service technician.
	The solid state relay is faulty.	Call a service technician.
One of the heat zones is overheating. (The display reads "TOO HOT".)	The interface board is faulty.	Call a service technician.
	The solid state relay is faulty.	Call a service technician.

PROBLEM	PROBABLE CAUSE	REMEDY
The exhaust hood and grill will not turn on when the fan interlock switch is placed in the ON position.	The restaurant circuit breaker has been tripped.	Reset the circuit breaker.
	The fan disconnect switch on the roof is in the OFF position.	Place the switch in the ON position.
	The fan interlock cord is not connected properly.	Reconnect the cord.
	The fan interlock switch is faulty.	Call a service technician.
The exhaust hood alone does not turn on when the fan interlock switch is in the ON position.	The fan interlock switch is faulty.	Call a service technician.
	Loose or broken wires.	Call a service technician.
The grill alone will not turn on when the fan interlock switch is in the ON position.	The ansul reset tripped.	Press the ansul reset button.
	The fan interlock switch is faulty.	Call a service technician.
	The fuse in the control box is faulty.	Call a service technician.
The upper platen will not stay in the COOK or STANDBY position.	Temperature is insufficient to satisfy the indicator LED's.	Wait until the indicator LED's turn green.
	The control harness is faulty.	Call a service technician.
	The processor control is faulty.	Call a service technician.
	The interface board is faulty.	Call a service technician.
	The latch switch is faulty.	Call a service technician.
	The latch solenoid is faulty.	Call a service technician.
	The pneumatic system is faulty.	Call a service technician.
The upper platen will not stay in the COOK position, but will stay in the STANDBY mode.	The processor control is not set properly.	Call a service technician.
The upper platen will not stay in the STANDBY mode, but will stay in the COOK position.	Incorrect use of the STANDBY button.	Press the STANDBY button within five seconds of lowering the platen into the COOK position.
	Faulty wire connections.	Call a service technician.
The upper platen opens too rapidly.	The orifice/check valve is incorrect or missing.	Call a service technician.

PROBLEM	PROBABLE CAUSE	REMEDY
The product is under-cooked or overcooked.	The release material sheet is worn.	Replace the release material sheet.
	The upper platen or lower grill surface is not clean and/or has carbon build-up.	Closing procedures must be followed to properly clean the upper platen and the lower grill surface and to remove carbon build-up.
	Incorrect cooking time.	Reset the processor control for the correct time.
	Incorrect temperature.	Adjust the processor control to the proper setting.
	The preset gap height is incorrect.	Call a service technician.
	The heating zone is not heating.	Call a service technician.
The product is not cooking evenly.	The upper platen or lower grill surface is not clean and/or has carbon build-up.	Closing procedures must be followed to properly clean the upper platen and the lower grill surface and to remove carbon build-up.
	Release material sheet is worn.	Replace release material sheet.
	The platen is not level.	Re-level the platen.
	Air pressure is not high enough.	Call a service technician.
	The preset gap height is incorrect.	Call a service technician.
The product is not recognized.	The grill is not set in the Auto Product Recognition mode.	Correct the product menu settings.
	The product is out of specification (examples: freezer burned, warped, too thick, or too thin).	Use good product that is within specification.
The platen will not auto-level.	Defective motors and cables.	Call a service technician.
	Defective motor interface board.	Call a service technician.
	Loose harness connections.	Call a service technician.
	Defective main display controller.	Call a service technician.
The display reads "UPPER PLATEN STUCK".	The arm bearings are dirty.	Call a service technician.
	The air cylinder is faulty.	Call a service technician.
	Plugged air lines to cylinders.	Call a service technician.

GAS ZONES ONLY

PROBLEM	PROBABLE CAUSE	CORRECTIVE ACTION
The display reads "BLOWER FAILURE".	The blower is faulty.	Call a service technician.
	The pressure switch is faulty.	Call a service technician.
The burner will not light. The display reads "IGNITION FAILURE".	The quick disconnect gas hose is not fully engaged.	Re-engage the quick disconnect.
	The manual shutoff valve is in the OFF position.	Turn the valve to the ON position.
	Air is in the gas hose.	Wait 5 minutes before relighting.
	The processor control is faulty.	Call a service technician.
	The spark ignition module is faulty.	Call a service technician.
	The gas solenoid is faulty.	Call a service technician.
	The electrode is faulty.	Call a service technician.
	The interface board is faulty.	Call a service technician.
The burner lights, but will not stay lit.	The electrode is faulty.	Call a service technician.
	Improper ground.	Call a service technician.
The burner lights, but the zone is cool or overheats.	The grill is out of calibration.	Calibrate the grill using the GR1M1 card instructions.
	The processor control is faulty.	Call a service technician.
	The thermocouple is faulty.	Call a service technician.

PARTS WARRANTY EXPLANATION

Class 103 Parts

The warranty for new equipment Class 103 parts is one year from the original date of unit installation, with a replacement parts warranty of three months.

Class 212 Parts

The warranty for new equipment Class 212 parts is two years from the original date of unit installation, with a replacement parts warranty of twelve months.

Class 512 Parts

The warranty for new equipment Class 512 parts is five years from the original date of unit installation, with a replacement parts warranty of twelve months.

Class 000 Parts

Class 000 parts are considered wear items - no warranty.

Class *** Parts

See warranty explanation on the back of the check-out card.

CAUTION: Warranty is valid only if the parts are authorized Taylor parts, purchased from an authorized Taylor Distributor, and the required service work is provided by an authorized Taylor service technician.

Taylor reserves the right to deny warranty claims on equipment or parts if non-approved parts or refrigerant were installed in the machine, system modifications were performed beyond factory recommendations, or it is determined that the failure was caused by neglect or abuse.

ORDERING/SERVICE INFORMATION

Taylor Distributor: _____

Address: _____

Telephone: _____

Date of Installation: _____

Data Label

The data label provides necessary information that the operator should record and refer to when calling for parts or service. The data label is located in the front panel.

Complete the following information for quick reference when this information is requested.

1. Model Number: _____
2. Serial Number _____
3. Electrical Specs:
Voltage _____ Cycle _____ Phase _____
4. Maximum Fuse Size: _____ Amps

Parts Warranty

Warranty is valid only if the parts are authorized Taylor parts, purchased from an authorized Taylor Distributor, and the required service work is provided by a factory authorized service technician. Taylor reserves the right to deny warranty claims on equipment or parts if non-approved parts were installed in the machine, system modifications were performed beyond factory recommendations, or it is determined that the failure was caused by neglect or abuse.

Note: Constant research results in steady improvements; therefore, information in this manual is subject to change without notice.

Release Material

Please refer to the following part numbers when ordering release material:

Upper platen release material:

Saint Gobain: DC WRIN 02701-003

Taconic: DC WRIN 02701-000

Lower release material:

Saint Gobain: DC WRIN 02198-009

NON-SCHEDULED MAINTENANCE



WARNING: INSPECTION, TESTING, AND REPAIR OF ELECTRICAL EQUIPMENT SHOULD ONLY BE PERFORMED BY QUALIFIED SERVICE PERSONNEL.



ALL ELECTRICAL CONNECTIONS SHOULD BE DISCONNECTED AND THE HOOD CIRCUIT BREAKER TURNED OFF WHEN SERVICING THE GRILL. FAILURE TO DO SO MAY RESULT IN EQUIPMENT DAMAGE OR PERSONAL INJURY.

SYSTEM SET-UP

To enter the SYSTEM SET-UP menu, perform the following steps.

1. While in the AM/PM AUTO Mode, press the  key. The following screen will display.

PRESS ENTER FOR
PROGRAMMING

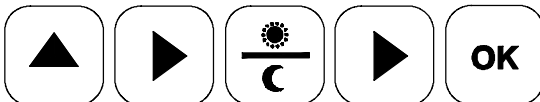

2. Press the  key to display the passcode entry screen.
3. Enter the Manager Menu passcode by pressing the keys in this order:



4. After the passcode has been entered, press the  key until the screen displays "SYSTEM SETUP."

The following screen will display.

PRESS ENTER FOR
SYSTEM SETUP

5. Press the  key to accept the selection.
6. Press the  key until the desired display screen appears.

Probe Calibration

1. Upon entering the SYSTEM SET UP menu, the following screen will display.

PROBE CALIBRATION
TOP BACK +00 424



Note: The Probe Calibration screen can also be accessed directly from the Main Menu without entering a passcode by pressing and holding the TEMP key for three seconds.

2. Place a pyrometer surface probe in the center of the selected heat zone.
3. If the displayed temperature on the controller is more than 5°F/3°C different from the pyrometer surface probe display:

Press the  key to increase the temperature to match the displayed temperatures.

Press the  key to decrease the temperature to match the displayed temperatures.



Note: The set of numbers that follow the zone name represent the previous calibration adjustment.

4. To calibrate the next zone, use the  key to move to the next zone.
5. Once calibration is complete, press the  key to save all changes.
6. Press the  key to return to the AM/PM AUTO Mode, or allow it to time-out after 5 seconds.

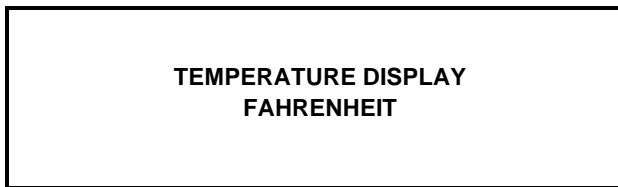

Display Temperature in °F/°C

1. From the SYSTEM SET UP menu, press the  key until the temperature display screen appears.

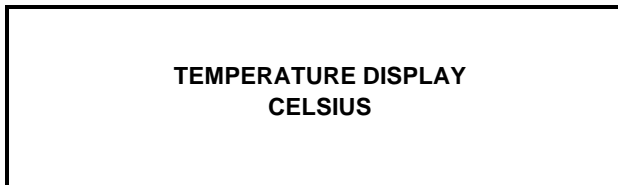

2. Pressing the  or  keys will alter the display message between F and C to display the temperature in degrees Fahrenheit or Celsius.







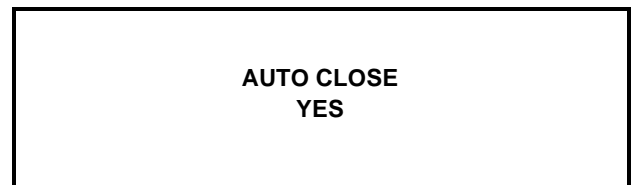

3. Press the  key to save the changes.
4. Press the  key to return to the AM/PM AUTO Mode.

5. Press the  key to exit from programming or let the display time out after 3-5 seconds.

Auto Close

1. From the SYSTEM SET UP menu, press the  key until the screen displays "AUTO CLOSE".





2. Use the  or  keys to scroll to either "YES" or "NO".
3. Press the  key to save the selection.
4. Press the  key to return to the AM/PM Mode.
5. Press the  key to exit from programming or wait for the display to time out after 3-5 seconds.



Speaker Volume

1. From the SYSTEM SET UP menu, press the  key until the screen displays "SPEAKER VOLUME".

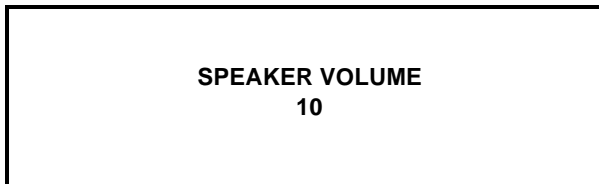

2. To increase the speaker volume, press the  key. To decrease the speaker volume, press the  key.







3. Press the  key to save the changes.
4. Press the  key to return to the AM/PM Mode.
5. Press the  key to exit from programming or let the display time out after 3-5 seconds.

Too Cool Delay

1. From the SYSTEM SET UP menu, press the  key until the display shows "TOO COOL DELAY".



2. To change the Too Cool Delay time, press the  or  keys to obtain the desired number.
3. Press the  key to confirm the selection.
4. Press the  key to return to the AM/PM Mode.
5. Press the  key to exit the programming mode or wait for the display to time out after 3-5 seconds.



Auto Prod Melt Time

This feature allows a one second delay before the platen is completely lowered into the cooking position. This feature is used to melt any ice crystals or deformity in the product.

IMPORTANT! DO NOT adjust the Auto Prod Melt Time.

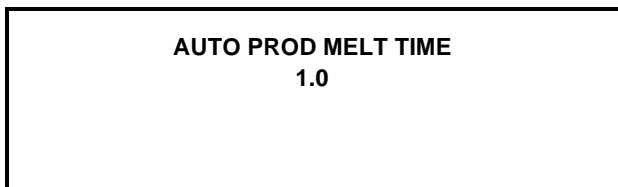
1. From the SYSTEM SET UP menu, press the  key until the screen displays "AUTO PROD MELT TIME".







2. Press the  key to return to the AM/PM Mode.
3. Press the  key to exit the programming mode, or wait for the display to time out after 3-5 seconds.

Gateway Enabled





The Gateway board was incorporated to be used with "Smart Equipment." It allows the manager to send a LON® service message out the power line.

IMPORTANT! To enable the Gateway, it must be enabled on each control panel. Perform the following steps on one control panel and then repeat the steps on the other control panels.



1. From the SYSTEM SET UP menu, press the  key to scroll to "GATEWAY ENABLED Y or N" (YES or NO).
2. Press the  key to change to "Y" (YES).
3. Press the  key.

4. Press the  key.
5. Press the  key to exit the programming mode.
6. Repeat these steps on the second control panel.
7. Repeat these steps on the third control panel to enable the Gateway on the entire grill.
8. Shut off the grill for 30 seconds before attempting to send a service pin.

Sending a Service Pin

1. While in the AM/PM AUTO or MANUAL Mode, access the Control Menu by pressing the  key twice to display "PROGRAMMING."
2. Pressing the  key will display the passcode entry screen.
(Note: No passcode is required. Proceed to the next step.)
3. Press  key until the SOFTWARE VERSION is displayed.
4. Press the  key until the GATEWAY VERSION number appears.

Note: If question marks appear instead of the Gateway version number, wait a few seconds. If the version number does not appear, shut the machine off. After approximately 30 seconds, restart the machine and repeat these steps.





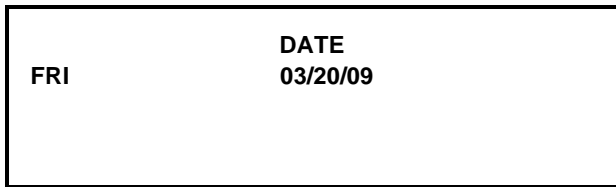

5. Press the  key to send the service pin.
6. Press the  key.
7. Press the  key to exit the programming mode.

Note: network commissioning process tool called the “wink” function can be initiated over the existing user interface to identify a piece of equipment. When the “wink” command is received through the network for the grill, an alarm will sound at maximum volume for two seconds.

Date

- From the SYSTEM SET UP menu, press the  key until the screen displays “DATE”.







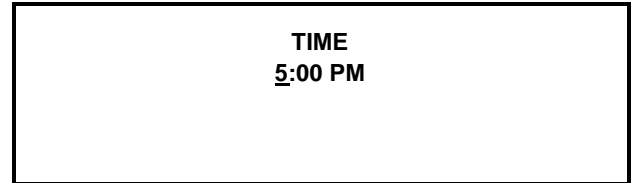

- Use the  key to place the cursor under the digit to be changed (i.e., weekday, month, day, or year).
- Use the  and  keys to change the digit. Scroll to the next digit to be adjusted and repeat these steps, until the desired date has been entered.
- Press the  key to accept the selection.
- Press the  key to return to the AM/PM Mode.
- Press the  key to exit the programming mode, or wait for the display to time out after 3-5 seconds.

Time

- From the SYSTEM SET UP menu, press the  key until the screen displays “TIME”.





- To make an adjustment to the time, press the  key to scroll to the digit to be changed (i.e., hour, minute, or AM/PM).
- Press the  and  keys to increase or decrease the digit. Scroll to the next digit to be adjusted and repeat these steps, until the desired time has been entered.
- Press the  key to accept the selection.
- Press the  key to return to the AM/PM Mode.
- Press the  key to exit the programming mode, or wait for the display to time out after 3-5 seconds.

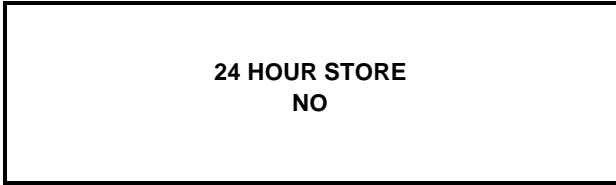

24 Hour Store



1. From the SYSTEM SET UP menu, press the  key until the screen displays "24 HOUR STORE".

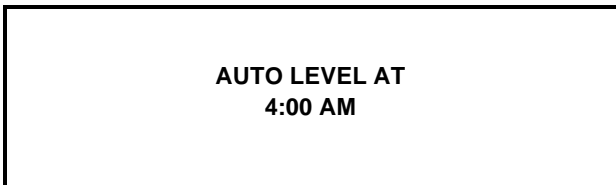

2. To select "YES", press the  key and press the  key. The following screen will display:



3. To make an adjustment to the time, use the  or  keys to scroll to the digit to be changed (i.e., hour, minute, and AM/PM).

4. Press the  and  keys to increase or decrease the digit. Scroll to the next digit to be adjusted and repeat these steps until the desired time has been entered.

5. Press the  key to accept the selection(s).

6. Press the  key to return to the AM/PM Mode.

7. Press the  key to exit the programming mode, or wait for the display to time out after 3-5 seconds.

MENU ITEMS

To enter the MENU ITEMS menu, perform the following steps.

1. While in the AM/PM AUTO Mode, press the  key. The following screen will display.



2. Press the  key to display the passcode entry screen.
3. Enter the Manager Menu passcode by pressing the keys in this order:

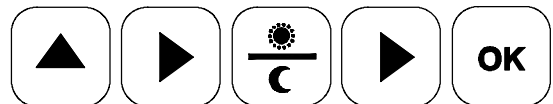





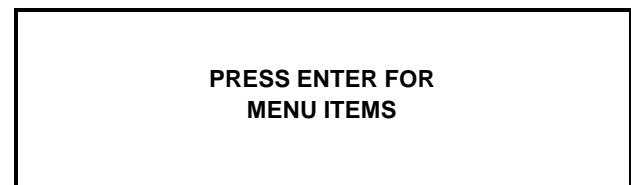

4. After the passcode has been entered, press the  key until the screen displays "MENU ITEMS."

The following screen will display.



5. Press the  key to accept the selection.





To View Settings For a Menu Item

1. Once the Control Menu passcode has been entered, press the  key for "MENU ITEMS".
2. Use the  or  keys to scroll to the desired menu item.
3. Press the  key to select the menu item.
4. Use the  or  keys to scroll through the menu items.

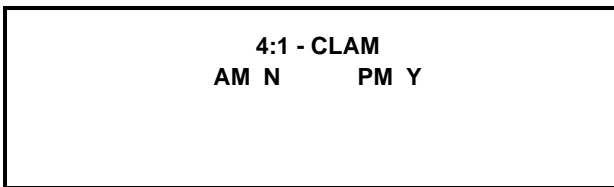
To Change a Menu Item (AM or PM)

1. After selecting the item, press the  key.
2. The screen will display the item and "AM Y/N PM Y/N."





3. To change the selection, press the  or  keys until the desired AM or PM selection is displayed.
4. Press the  key to save the selection.
5. Press the  key twice to return to the AM/PM AUTO Mode.
6. Press the  key to exit the programming mode, or let the display time-out after 3-5 seconds.

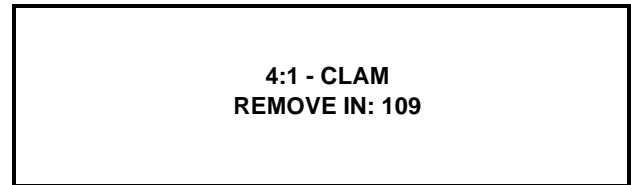

Change Product Cook Times (Remove In)



1. After selecting the item, press the  key until the screen displays "REMOVE IN 000".



2. To change the setting, press the  or  keys until the desired time is displayed.

Note: Each press of the  key will move the cursor to the next digit on the screen.

3. Press the  key to save the changes.
4. Press the  key twice to return to the AM/PM AUTO Mode.
5. Press the  key to exit the programming mode.





Note: Pressing the  key exits the programming mode immediately. If the  key is not pressed, the display automatically times-out after 3-5 seconds and exits the programming mode.

Change Remove Alarm Mode

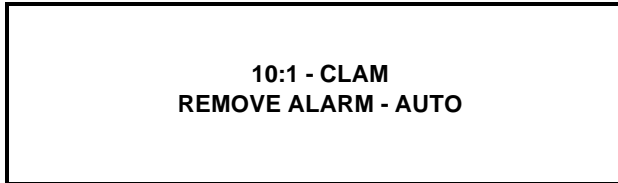
1. After selecting the item, press the  key until the screen displays "REMOVE ALARM".

Example of a screen:





2. To change the setting, press the  or  keys until the desired setting is displayed.
3. Press the  key to save the changes.
4. Press the  key twice to return to the AM/PM AUTO Mode.
5. Press the  key to exit the programming mode, or let the display time out after 3-5 seconds.

Change Remove Gap Mode

1. After selecting the item, press the  key until the screen displays "REMOVE GAP".

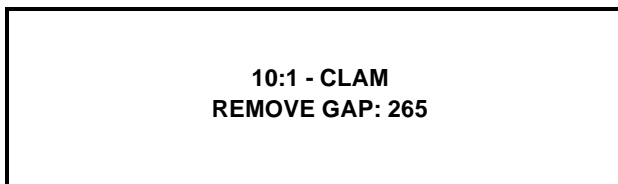

Example of a screen:



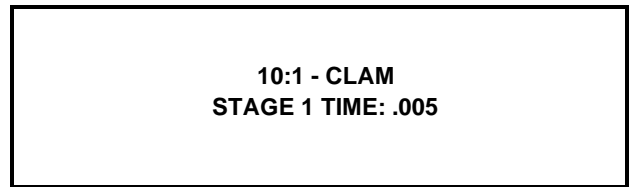

2. To change the setting, press the  or  keys until the desired setting is displayed.

3. Press the  key to save the changes.
4. The Stage 1 Time screen will display:

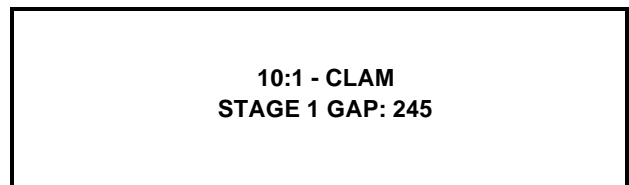

5. To change the setting, press the  or  keys until the desired setting is displayed.
6. Press the  key to save the changes.
7. The Stage 1 Gap screen will display:





8. Press the  key twice to return to the AM/PM AUTO Mode.
9. Press the  key to exit the programming mode, or let the display time out after 3-5 seconds.

Change Product Cook Temperatures (Top Temp/Bottom Temp)

1. After selecting the item, press the  key until the screen displays "TOP TEMP".

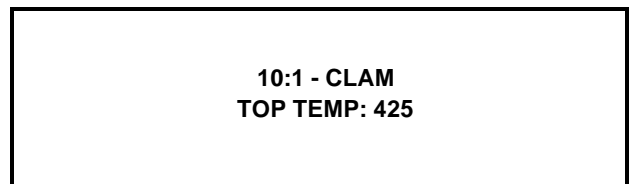

The following screen will display.

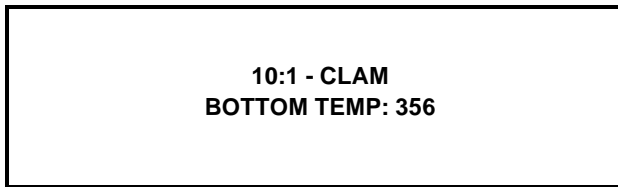

2. To change the setting, press the  or  keys to change the temperature.

- Press the  key, the screen will display "BOTTOM TEMP ____".



- To change the setting, press the  or  keys to change the temperature.

- Press the  key to save the changes.

- Press the  key to return to the AM/PM AUTO Mode.



- Press the  key to exit the programming mode, or let the display time out after 3-5 seconds.

Change Auto Selection Mode

- After selecting the item, press the  key until the screen displays "AUTO SELECTION".

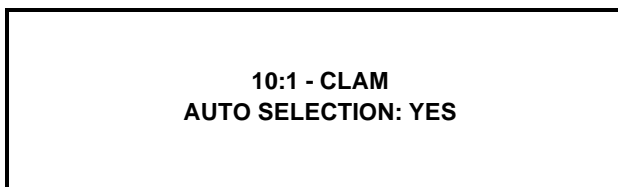
Example of a screen:



- To change the selection, press the  or  keys until the desired selection (YES or NO) is displayed.

- Press the  key to save the changes.

- Press the  key twice to return to the AM/PM AUTO Mode.



- Press the  key to exit the programming mode, or let the display time out after 3-5 seconds.

Changing Product Thickness Recognition For Menu Item (Auto Gap)

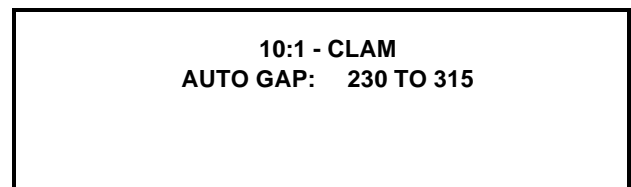

IMPORTANT! Settings should NOT be changed unless authorized by a Taylor Service Representative. This change should only be performed to adjust deformed product. Before attempting to change the product thickness settings, cook the deformed product in the MANUAL mode.

- Press the  key until the screen displays "AUTO GAP".
- The screen will show two sets of numbers. The first set of numbers is the minimum gap of the item. The second set of numbers is the maximum gap of the item.



- Press the  or  keys to adjust the minimum gap.

Note: Each press of the  key will move the cursor to the next digit on the screen.

- Press the  key to accept the selection.
- Press the  or  keys to adjust the maximum gap.



- Press the  key to accept the selection.

- Press the  key twice to return to the Operating Mode. The display will time-out after 3-5 seconds.

- Press the  key to exit the Programming mode.

Programming Optional Menu Items

1. Once the Control Menu passcode has been entered, press the  key for "MENU ITEMS".





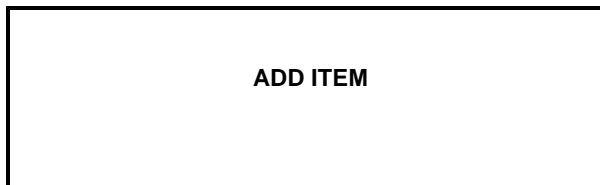

2. Use the  or  keys to scroll to "ADD ITEM".

The following screen will display.





3. Press the  key. The following screen will display.





4. Use the  or  key to change the first default character into the first desired character.
5. Move the cursor to the next digit by using the  key.
6. Continue entering the appropriate characters until the complete item name has been entered.
7. Press the  key until any remaining default characters are removed.
8. Press the  key. The screen will display, "TYPE: CLAM". Press the  or  key to select "CLAM" or "FLAT."
9. Press the  key.



Flat Selection Procedures

- a. If "FLAT" was selected, the screen will display "FUNCTIONS: 0". The new flat item can have a maximum of three functions: Turn, Sear, and Turn/Sear.



- b. Use the  key to scroll to the appropriate number of functions and press the  key. The screen will display "FUNC1: TURN."



- c. Use the  key to scroll to the desired function. Press the  key to accept the selection.

Note: For items with multiple functions, repeat these steps until all the functions have been entered.

- d. After the  key has been pressed, the screen will display, "AM __ PM __". Use the  or  keys to scroll to the appropriate selection.

- e. Press the  key. The screen will display the first function and "000". (Example: TURN IN: 000.)

- f. Press the  or  keys to change the time in single increments. The time can also be changed in increments of 10's and 100's by moving the cursor, per the following procedure:

Press the  key to move the cursor to the next digit. Change the time, using the  or  keys. Repeat this sequence for each digit until the correct time is displayed.



- g. Press the  key to accept the selection. The screen will display the first function and "ALARM: AUTO".

Use the  key to scroll to the desired selection (AUTO or MANU)

and press the  key.

Note: For items with multiple functions, repeat these steps until all functions have been entered.

- h. After pressing the  key, the screen will display "REMOVE IN 000."

- i. Use the  or  keys to enter the appropriate time.



Note: Pressing the  key moves the cursor to the next digit on the screen.

- j. Press the  key. The screen will display "REMOVE ALARM: AUTO."



- k. Use the  or  keys to scroll to "AUTO" or "MANUAL".

- l. With the appropriate selection displayed, press the  key. The screen will display "TOP TEMP OFF."



- m. Press the  key. The screen will display the default temperature.

- n. Press the  or  keys to increase or decrease the temperature in single increments. The temperature can also be changed in increments of 10's and 100's by moving the cursor, per the following procedure:

Press the  key to move the cursor to the next digit. Change the



temperature using the  or  keys. Repeat this sequence for each digit until the correct temperature is displayed.

- o. Press the  key. The screen will display "BOTTOM TEMP OFF."

- p. Press the  key. The screen will display the default temperature. Use the  or  keys to increase or decrease the temperature.

Note: Pressing the  key moves the cursor to the next digit on the screen.

- q. Press the  key to accept the selection.



- r. Press the  key twice and then press the  key to exit the programming mode.

Clam Selection Procedures



- a. If "CLAM" was selected, the screen will display "GAP STAGES: 0." If the new item is a multi-gap product, use the  key to add the desired gap stages (maximum of 3).

Note: "GAP STAGES" is typically set to "0".



- b. Press the  key. The screen will display "AM __ PM __".

- c. Use the  or  keys to scroll to the appropriate selection.

- d. Press the  key. The screen will display "REMOVE IN 000."

- e. Press the  or  keys to enter the time in single increments. The time can also be changed in increments of 10's and 100's by moving the cursor, per the following procedure:

Press the  key to move the cursor to the next digit. Change the



time, using the  or  keys. Repeat this sequence for each digit until the correct time is displayed.

- f. Press the  key. The screen will display "REMOVE ALARM: AUTO."



- g. Use the  or  keys to scroll to "AUTO" or "MANUAL".

- h. With the appropriate selection

displayed, press the  key. The screen will display "REMOVE GAP: 000".

- i. Use the  or  keys to enter the product gap specification in single increments. The gap can also be entered in increments of 10's and 100's by moving the cursor, per the following procedure:

Press the  key to move the cursor to the next digit. Change the



gap setting using the  or  keys. Repeat this sequence for each digit until the correct gap is displayed.

- j. Press the  key to save the selection.

For products with "0" gap stages, proceed to step p.



For multi-gap products only, follow steps k. through o.

- k. After pressing the  key, the screen will display "STAGE1 TIME: 000."

- l. Use the  or  keys to enter the appropriate time.

Note: Pressing the  key moves the cursor to the next digit on the screen.



- m. Press the  key. The screen will display, "STAGE1 GAP: 000."

- n. Use the  or  keys to enter the appropriate gap setting. Press the  key to save the selection.



Note: Pressing the  key moves the cursor to the next digit on the screen.

- o. If the menu item has additional gap stages, repeat the previous steps until all gap stages have been programmed.



- p. After the  key has been pressed, the screen will display "TOP TEMP OFF."

- q. Press the  key. The screen will display the default temperature. Press the  or  keys to increase or decrease the temperature in single increments.



The temperature can also be changed in increments of 10's and 100's by moving the cursor, per the following

procedure: Press the  key to move the cursor to the next digit. Change the temperature using the  or  keys. Repeat this sequence for each digit until the correct temperature is displayed.

r. Press the  key. The screen will display "BOTTOM TEMP OFF."

s. Press the  key. The screen will display the default temperature. Use the  or  keys to increase or decrease the temperature.

Note: Pressing the  key moves the cursor to the next digit on the screen.



t. Press the  key. The screen will display "AUTO SELECTION: NO". Use the  or  keys to scroll to "YES or NO".

Note: AUTO SELECTION is typically set to "NO".

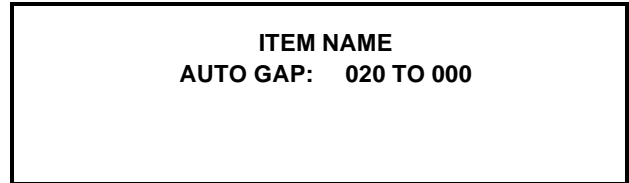

u. Press the  key. If "AUTO SELECTION: NO" was selected, proceed to step y.



v. If "AUTO SELECTION: YES" was selected, the AUTO GAP screen will display. This screen shows two sets of numbers. The first set of numbers is the minimum gap of the item. The second set of numbers is the maximum gap of the item. (See example screen below.)

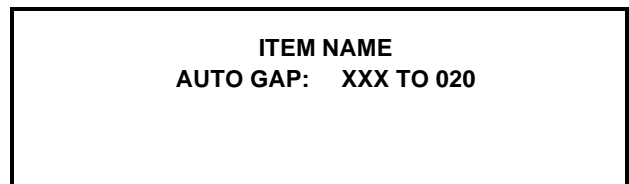



w. Press the  or  keys to adjust the minimum gap. Press the  key to accept the selection. (See example screen below.)



x. Press the  or  keys to adjust the maximum gap. Press the  key to accept the selection.







y. The screen will display "AM __ PM __". Use the  or  keys to scroll to the appropriate selection.

Press the  key to accept the selection.

z. Press the  key twice and then press the  key to exit the programming mode.

Removing Menu Items

Core menu items cannot be removed. Other menu items can be removed by performing the following steps.

1. Once the Control Menu passcode has been entered, press the  key for "MENU ITEMS".
2. Use the  or  keys to scroll to the menu item to be removed.
3. Press the  key until the "REMOVE IN" screen is displayed.
4. Press and hold the  key until the menu item is removed.
5. Press the  key twice and then press the  key to exit the programming mode.

AUTO LEVELING

1. Ensure the grill surfaces are clean and the release sheets are installed.
2. Allow the grill to reach operating temperature (minimum of 45 minutes).
3. While the grill is in the AM/PM AUTO Mode, press the  key twice. The following screen will be displayed.

PRESS ENTER FOR
AUTO LEVELING

4. Press the  key. The following screen appears.

CLOSE GRILL CLAM FOR
AUTO LEVELING

5. Press the STANDBY button.
(See Figure 116.)

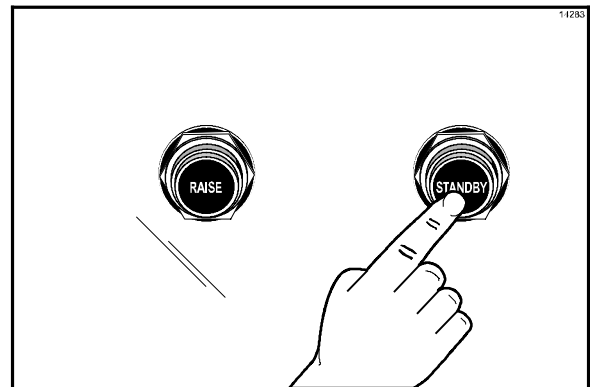

Figure 116

The following screen appears.

PLEASE WAIT FOR
AUTO LEVELING

6. The platen will raise after it has auto leveled.

C845 WIRING DIAGRAM 073090-23

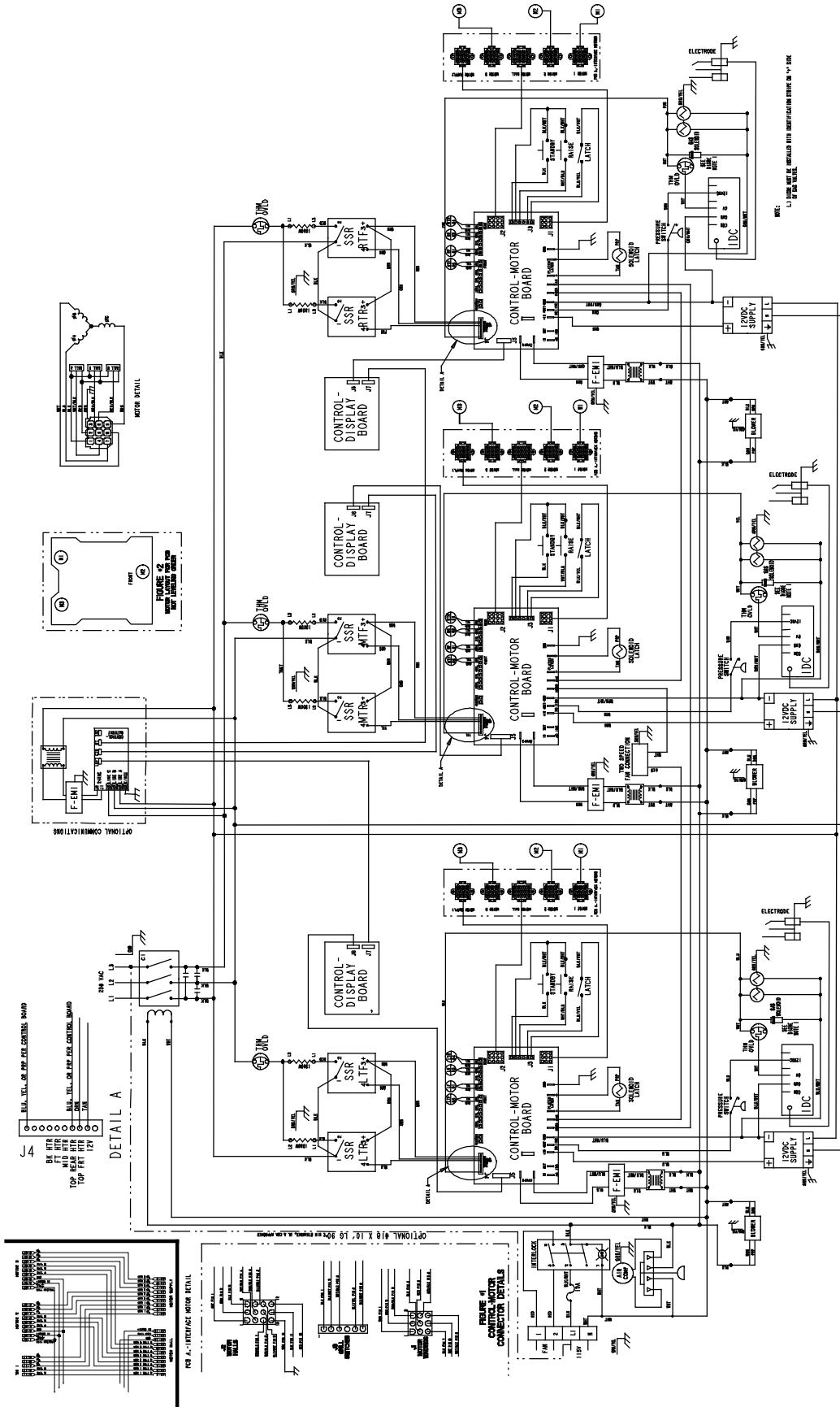

C845 WIRING DIAGRAM 073700-40

