

# Clamshell Grill Taylor Models C850, C852, C854, C856, C858, & C860



This equipment chapter is to be inserted in the appropriate section of the Equipment Manual.

**Manufactured exclusively for**

**McDonald's® By**

**Taylor Company®**

750 N. Blackhawk Blvd.

Rockton, IL 61072

McDonald's® Hotline:

(877-435-7623)

service@taylor-company.com

## TABLE OF CONTENTS



Warranty .....	3
Introduction .....	3
Safety .....	3
Parts Identification/Function and Exploded View .....	7
Important to the Operator .....	28
Equipment Setup and Close Procedures .....	33
Menu Screens .....	37
Sausage, Circular Bacon and Patty Placement Guide .....	51
Standby Procedures .....	53
Cleaning After Each Run of Product (Using Lower Release Sheets) .....	53
Cleaning After Each Run of Product (Not Using Lower Release Sheets) .....	54
Daily Cleaning Procedures (Using Lower Release Sheets) .....	56
Cleaning Procedure-24 Hour Stores (With Lower Release Sheets) .....	65
Daily Cleaning Procedures (Without Lower Release Sheets) .....	65
Cleaning Procedure-24 Hour Stores (Without Lower Release Sheets) .....	72
Quarterly Recovery Mode Procedures .....	72
Troubleshooting Guide .....	77
Equipment Troubleshooting .....	78
Product Troubleshooting .....	79
Limited Warranty On Equipment .....	80
Limited Warranty On Parts .....	82
Ordering/Service Information .....	85

### Warranty

Warranty information is contained in this Equipment Manual. Refer to the warranty information listed in the Limited Warranty on Equipment and Limited Warranty on Parts sections and to the warranty classifications listed in the Parts Identification/Function section when service is performed on your machine.

It is recommended that the operator take the necessary time to carefully read through the complete warranty information. Thoroughly understand your warranty protection before you begin operation.

For any questions pertaining to the Taylor Warranty, please contact Taylor Company, Rockton, Illinois 61072.

This manual is for the exclusive use of licensees and employees of McDonald's Corporation.

©2006 McDonald's Corporation

All Rights Reserved

November, 2006 (Original Publication)

(Updated May, 2018 )

EM SD11

Printed in

The United States of America



## WARRANTY

Warranty information is contained in this Equipment Manual. Refer to the warranty information listed in the Limited Warranty on Equipment and Limited Warranty on Parts sections and to the warranty classifications listed in the Parts Identification/Function section when service is performed on your machine.

It is recommended that the operator take the necessary time to carefully read through the complete warranty information. Thoroughly understand your warranty protection before you begin operation.

For any questions pertaining to the Taylor Warranty, please contact Taylor Company, Rockton, Illinois 61072.

## INTRODUCTION

**Note:** *These appliances are intended to be used for commercial applications, for example in kitchens of restaurants, canteens, hospitals and in commercial enterprises such as bakeries, butcheries, etc., but not for continuous mass production of food.*

The models contained in this Operator Manual are the C850, C852, C854, C856, C858, and C860. The Model C850 is an electric grill with one upper platen. The Model C852 is an electric grill with two independent upper platens. The Model C854 is an electric grill with one upper platen and a shortened lower cooking surface. The Model C856 is an electric grill with two independent upper platens and two independent shortened lower cooking plates. The Model C858/C860 is an electric grill with three independent upper platens and three independent lower cooking plates.

These grills provide automatic leveling of the plates. They are capable of cooking a variety of products and feature two cooking options, Auto and Manual.

**Auto Option:** The grills automatically detect the product placed on the grill plate (menu items that are cooked double-sided, only) and set the appropriate cooking parameters.

**Manual Option:** After the operator selects the desired product to be cooked, the grills set the appropriate cooking parameters.

These grills provide all the features of a flat grill, as well as the advantages of two-sided cooking.

## SAFETY



**DANGER!** Improper installation, adjustment, alteration, service, or maintenance can cause property damage, injury, or death. Read the installation, operating, and maintenance instructions thoroughly before installing or servicing this equipment.

Always follow these safety precautions when operating the grill:



**NOTICE! DO NOT** operate the grill without reading this operator's manual. Failure to comply may result in equipment damage or personal injury. This manual should be kept in a safe place for future reference.



**IMPORTANT!** *This appliance is to be used only by trained personnel. It is not intended for use by children or people with reduced physical, sensory, or mental capabilities or lack of experience and knowledge, unless given supervision or instruction concerning the use of the appliance by a person responsible for their safety. Children should be supervised to ensure that they do not play with the appliance.*



**WARNING! DO NOT** install the unit in an area where a water jet or a steam cleaner could be used. **DO NOT** use a water jet or a steam cleaner to clean or rinse the grill. Failure to follow this instruction may result in serious electrical shock. In addition, water may collect inside the grill and destroy electrical components and cause injury from hot steam.



**WARNING! DO NOT** operate the grill unless it is properly grounded. Failure to comply may result in equipment damage or personal injury.



**WARNING!** All repairs must be performed by an authorized Taylor service technician. The main power supplies to the grill must be disconnected prior to performing any repairs. Failure to comply may result in equipment damage or personal injury.

These grills are designed for indoor use only.

**Note:** Only instructions originating from the factory or its authorized translation representative(s) are considered to be the original set of instructions.



**IMPORTANT!** This equipment is provided with an equipotential grounding lug that is to be properly attached to the rear of the frame by the authorized installer. The installation location is marked by the equipotential bonding symbol (5021 of IEC 60417- 1) on the removable panel and the frame.



**WARNING!** Avoid injury.

- **DO NOT** operate the grill unless it is properly grounded.
- **DO NOT** operate the grill with larger fuses than specified on the data label.
- **DO NOT** operate the grill unless all service panels and access doors are attached with screws.
- This appliance is intended to be moved for cleaning.
- This appliance is to be connected with flexible connections for equipotential bonding and connection to services such as electricity supply, water supply, gas supply and steam supply such that the appliance can be moved in the direction required for cleaning a distance not

less than the dimension of the appliance in the direction of movement plus 500 mm without the flexible connections becoming taut or being subject to strain.

- All repairs must be performed by an authorized Taylor service technician.
- The main power supplies to the grill must be disconnected prior to performing any repairs.
- Only authorized Taylor service technicians or licensed electricians may install a plug or replacement cord on this equipment.
- Stationary appliances which are not equipped with a power cord and a plug or other device to disconnect the appliance from the power source must have an all-pole disconnecting device with a contact gap of at least 1/8 in. (3 mm) installed in the external installation.
- Appliances that are permanently connected to fixed wiring and for which leakage currents may exceed 10 mA, particularly when disconnected or not used for long periods, or during initial installation, shall have protective devices such as a GFI to protect against the leakage of current installed by the authorized personnel to the local codes.
- Supply cords used with this machine shall be oil-resistant, sheathed flexible cable not lighter than ordinary polychloroprene or other equivalent synthetic elastomer-sheathed cord (code designation 60245 IEC 57) installed with the proper cord anchorage to relieve conductors from strain, including twisting, at the terminals and protect the insulation of the conductors from abrasion. If the supply cord is damaged, it must be replaced by the manufacturer, its service agent, or similarly qualified person, in order to avoid a hazard.

Failure to follow these instructions may result in severe injury or death from electrocution.



**WARNING!** This appliance must be isolated from all combustible construction and materials including but not limited to walls, partitions, furniture, floors, curtains, paper, boxes, and decorations. Failure to comply may result in fire and cause destruction and severe injury.



**WARNING!** For your safety **DO NOT** store or use gasoline or other flammable vapors or liquids in the vicinity of this or any other appliance. Failure to comply could result in a fire hazard.



**IMPORTANT!**

- **DO NOT** obstruct the ventilation openings at the rear of this appliance.
- **DO NOT** obstruct the flow of air in and around the grill.
- **DO NOT** operate the grill unless all service panels and access doors are attached with screws.

Failure to comply may result in personal injury from gas or electrical components.



**CAUTION!** Use extreme caution while setting up, operating, and cleaning the grill to avoid coming in contact with hot grill surfaces or with hot grease. Failure to comply may result in burn injuries.



**CAUTION!** The grill must be placed on a level surface.

- To ensure thorough cleaning, the grill must be pulled away from the wall. When pulling the grill away from the wall for cleaning and before returning the grill to its original position, first always check to ensure that all four casters are aligned and parallel with the grill from front to back and that the lock nuts are tight. If the

casters are properly aligned, unlock the front casters and use care to smoothly and slowly roll the grill into or out of place. (Do not lift.) If there is a discontinuity in the floor, use extra care to ensure that the unit remains as level as possible from side to side. Failure to do so may cause the grill to tip, leading to grill damage or personal injury. When returning the grill to its original position, use extreme caution to smoothly and slowly roll the grill backward into place and lock the front casters.

Failure to follow these instructions may cause the grill to tip and can result in severe equipment damage or personal injury.



**NOTICE!** All warning labels that have been attached to the grill point out safety precautions to the operator.



**NOTICE!** The procedure(s) in this manual include the use of chemical products. These chemical products will be highlighted with boldface letters followed by the abbreviation HCS in the text portion of the procedure. See the hazard communication standard (HCS) manual for the appropriate material safety data sheet(s) (MSDS).

This unit is made using USA sizes of hardware. All metric conversions are approximate.

**Noise Level:** Airborne noise emission does not exceed 70 dB(A) when measured at a distance of 39 in. (1.0 m) from the surface of the machine and at a height of 62 in. (1.6 m) from the floor.



**IMPORTANT!** *If the crossed-out waste container symbol is affixed to this product, it signifies that this product is compliant with the EU Directive as well as other similar legislation in effect after August 13, 2005. Therefore, it must be collected separately after its use is completed and cannot be disposed as unsorted municipal waste. The user is responsible for returning the product to the appropriate collection facility, as specified by your local code.*

For additional information regarding applicable local laws, please contact the municipal facility and/or local distributor.

**PARTS IDENTIFICATION/FUNCTION AND EXPLODED VIEW**

**C850 Exploded View**

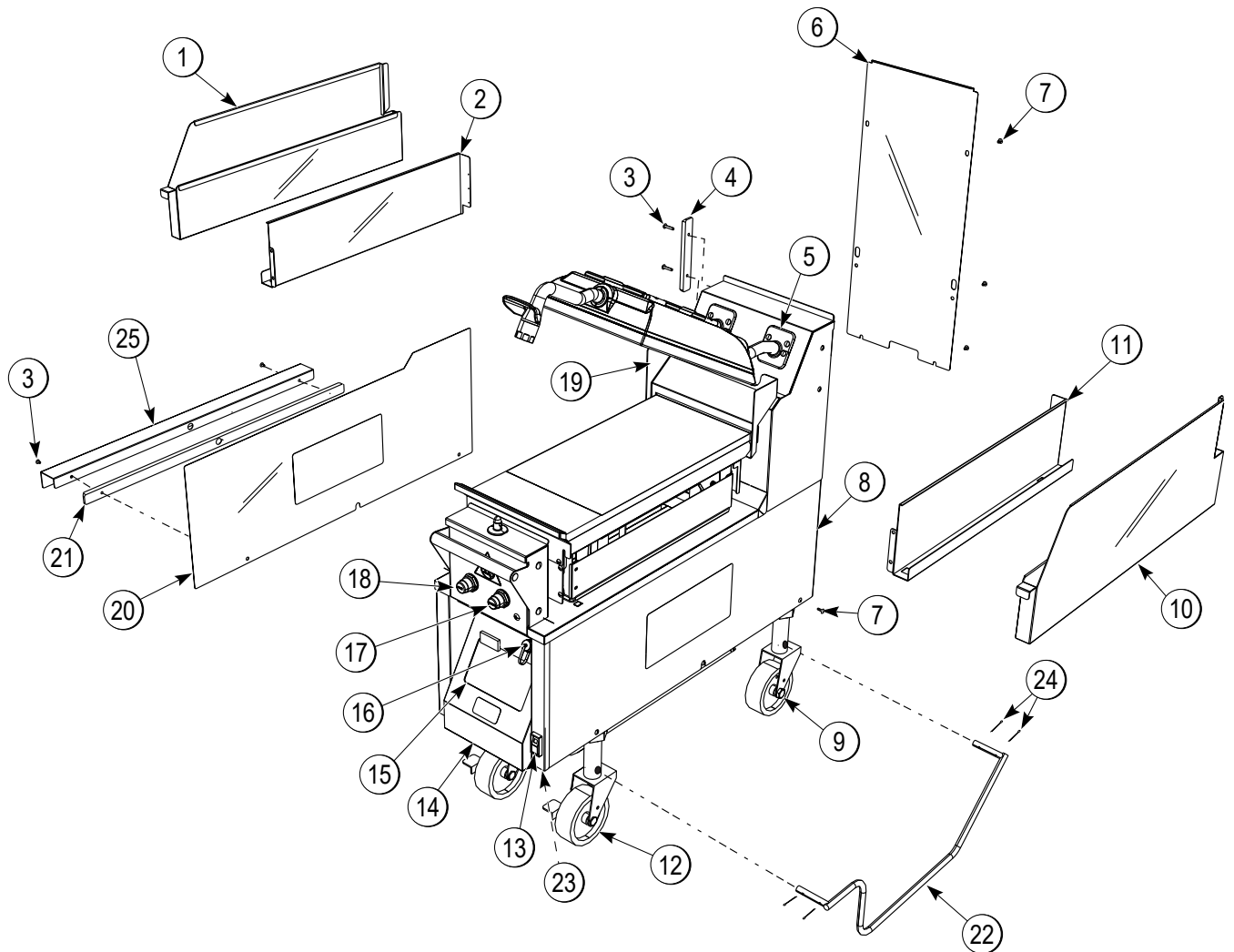

Figure-1

## C850 Exploded View

Item	Part No.	Description	Qty.	Function	Warr. Class
1	X84969	Can A.-Grease-L	1	Container for grease.	103
2	X84224	Shroud-Upper Side	1	Metal bracket that the grease can slides into, securing it next to the lower grill plate.	103
3	070695	Screw-10-32X1/2 Phil	4	Fastens bumpers to panels.	000
4	084549	Bumper	2	Protects grill from damage.	000
5	X73600-SER	Kit A.-Grease Shield	2	Fastens grease shields to rear shroud.	000
6	082959	Panel-Rear	1	Provides access to internal components for service and cleaning.	103
7	024298	Screw-10-32X3/8 Phil	34	Secures the panel to the frame.	000
8	082958	Panel-Side-Right	1	Provides access to internal components for service and cleaning.	103
9	078377-1	Caster-5 7-5/8 Stem	2	Allows grill mobility.	103
10	X84608	Can A.-Grease-R	1	Container for grease.	103
11	X84225	Shroud-Upper Side	1	Metal bracket that the grease can slides into, securing it next to the lower grill plate.	103
12	073240-3	Caster-5 7-5/8 Stem-Swivel W/ Lock	2	Prevents grill movement when the brake is used.	103
13	076989-WP	Switch-Rocker- DPST 10A	1	Activates power to the grill and the exhaust fans.	103
14	X84230	Door A.-Control	1	Houses the controls.	103
15	X85623-SER	Touchscreen A.	1	Controls all functions of the grill.	- - -
16	068583	Cover A.-USB Waterproof	1	Protects USB port from water damage.	103
17	076012	Button-Operator-Black	1	Activates the cook cycle, keeps the upper platen in the closed position, and displays STANDBY on the control. When pressed twice with one-second intervals between presses, the upper platen will automatically lower into the Standby position.	000
18	076011	Button-Operator-Red	1	Cancels Standby mode, raises the upper platen, and deactivates the Cook cycle.	000
19	X85465	Shield A.-Rear GRS	1	Prevents grease migration.	000
20	082957	Panel-Side-Left	1	Provides access to internal components for service and cleaning.	103
21	084613	Bumper	1	Protects grill from damage.	000
22	086984-1	Outrigger A.-Right	1	Stabilizes grill.	000
23	086985-1	Outrigger-Left	1	Stabilizes grill.	000
24	087002	Pin-Cotter 1/8 x 1 in.	8	Secures the outrigger to the caster.	000
25	085447	Spacer Bumper	1	Protects grill from damage.	000

# C852 Exploded View

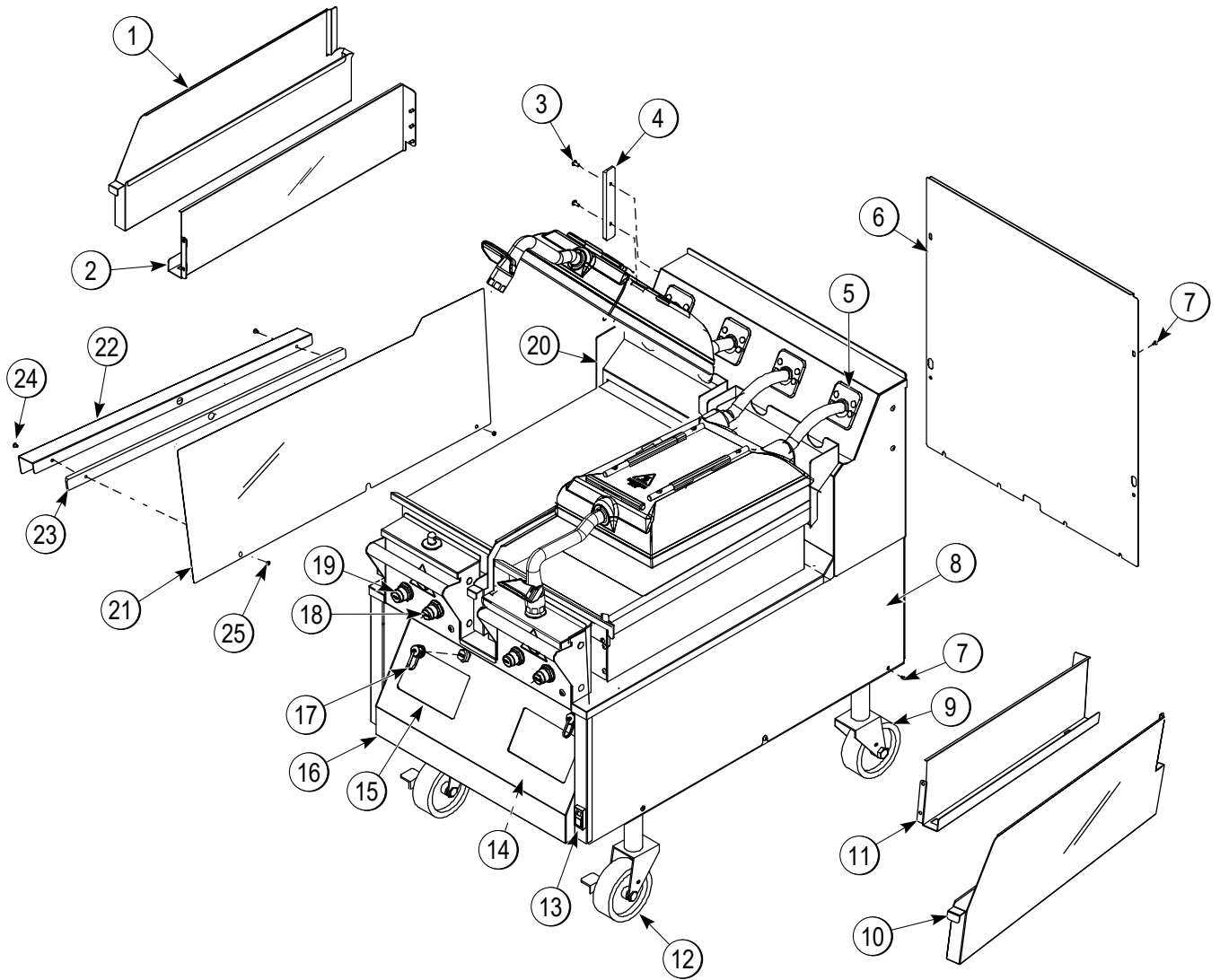

Figure-2

## C852 Exploded View

Item	Part No.	Description	Qty.	Function	Warr. Class
1	X84969	Can A.-Grease-L	2	Container for grease.	103
2	X84224	Shroud A.-Upper*LFT	1	Metal bracket that the grease can slides into, securing it next to the lower grill plate.	103
3	070695	Screw-10-32X1/2 PHIL	4	Fastens bumper onto panel.	000
4	084549	Bumper	1	Protects grill from damage.	000
5	X73600-SER	Kit A.-Grease Shield	4	Fastens grease shields to rear shroud.	000
6	084215	Panel-Rear	1	Provides access to internal components for service and cleaning.	103
7	024298	Screw-10-32X3/8 SLTD Truss	54	Secures the panel to the frame.	000
8	082958	Panel-Side-Right	1	Provides access to internal components for service and cleaning.	103
9	078377	Caster-5 7-5/8 Stem	2	Allows grill mobility.	103
10	X84608	Can A.-Grease-R	2	Container for grease.	103
11	X84225	Shroud A.-Upper*RT	1	Metal bracket that the grease can slides into, securing it next to the lower grill plate.	103
12	073240	Caster-5 7-5/8 Swivel W/Lock	2	Prevents grill movement when the lock is used.	103
13	076989-WP	Switch-Rocker- DPST 10A	1	Activates power to the grill and the exhaust fans.	103
14	X84265-23	Control A.-Right	1	Controls all functions of the grill.	---
15	X85623-SER	Touchscreen A.	1	Controls all functions of the grill.	---
16	X84255	Door A.-Welded	2	Houses the controls and the fan interlock switch.	103
17	068583	Cover A.-USB Waterproof	2	Protects USB port from water damage.	103
18	076012	Button-Operator- Black	2	Activates the cook cycle, keeps the upper platen in the closed position, and displays the message STANDBY on the control. When pressed twice with one-second intervals between presses, the upper platen will automatically lower into the Standby position.	000
19	076011	Button-Operator- Red	2	Cancels the Standby mode, raises the upper platen, and deactivates the Cook cycle.	000
20	X85465	Shield A.-Rear-GRS	2	Prevents grease migration.	000
21	082957	Panel-Side-Left	1	Provides access to internal components for service and cleaning.	103
22	085447	Space Bumper	1	Protects grill from damage.	000
23	084613	Bumper	1	Protects grill from damage.	000
24	033944	Screw-10-32x3/4 SLTD Truss	2	Secures the spacer to the bumper.	000
25	079150	Nut-10-32 Whiz Flange Lock	2	Secures the spacer to the bumper.	000

**C850/C852 Right Side View**

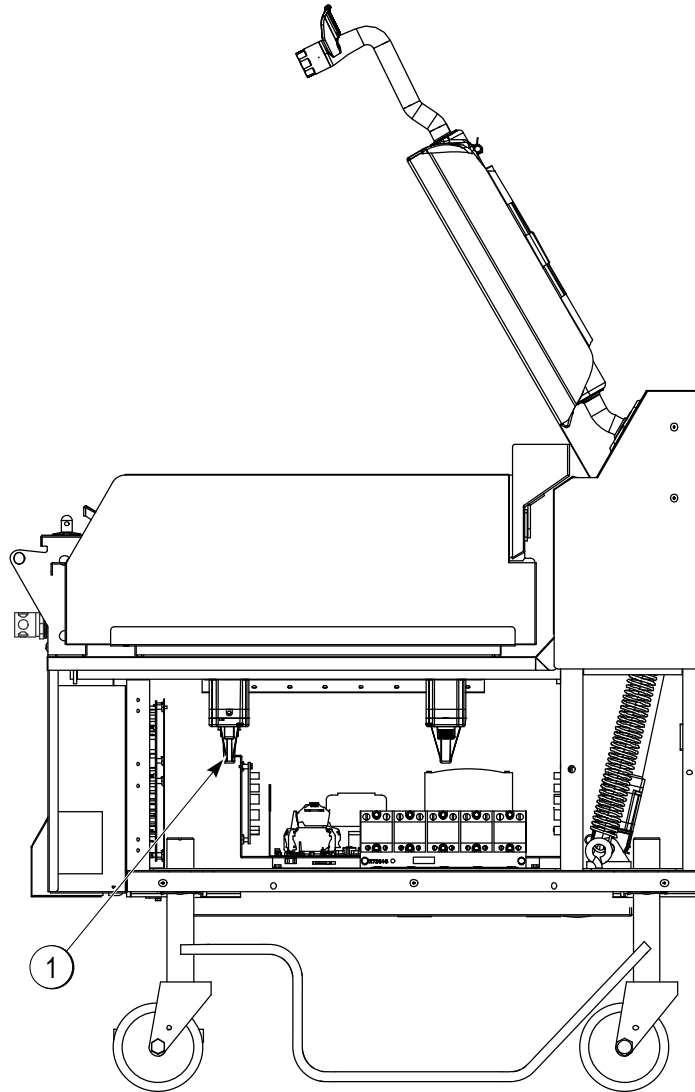

Figure-3 (C850 shown)

Item	Part No.	Description	Qty.	Function	Warr. Class
1	X84169-SER	Kit A.-Actuator Plate	3 (C850) 6 (C852)	Positions the cooking surface.	103

**C850/C852 Left Side View**

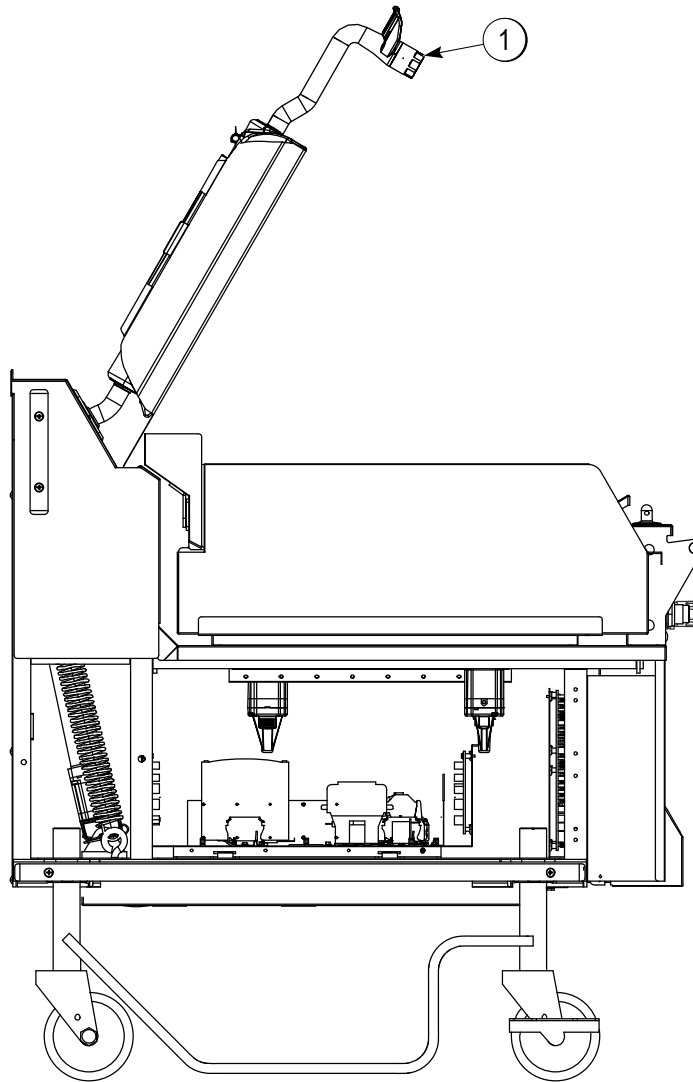

Figure-4 (C850 shown)

Item	Part No.	Description	Qty.	Function	Warr. Class
1	X85715	Handle A.-Align Ring	1 (C850) 2 (C852)	The handle clicks in to the platen latch when in the down position.	000

# C854 Exploded View

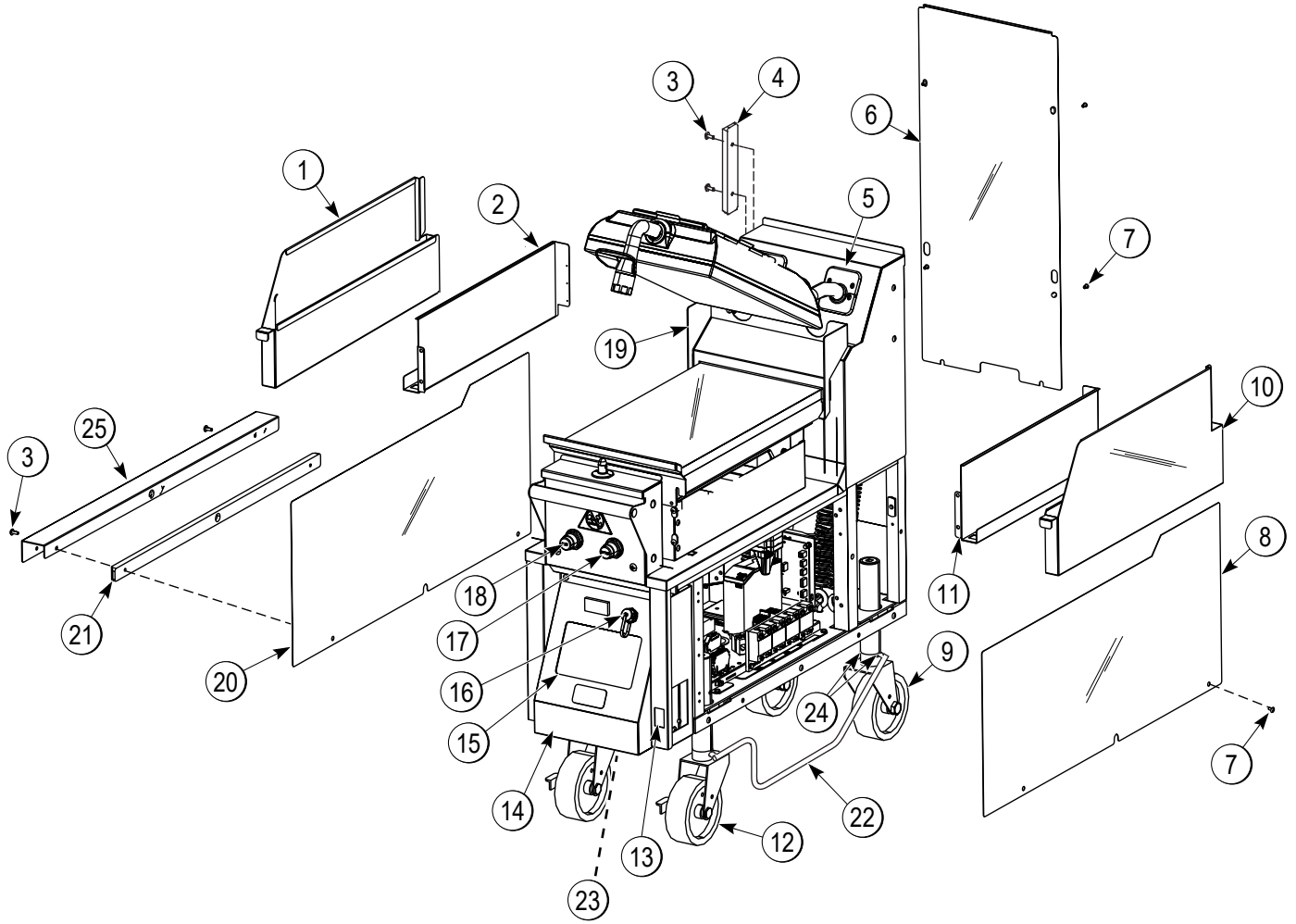

Figure-5

## C854 Exploded View

Item	Part No.	Description	Qty	Function	Warr. Class
1	X84971	Can A.-Grease-L	1	Container for grease.	103
2	X84248	Shroud A.-Upper*LFT	1	Metal bracket that the grease can slides into, securing it next to the lower grill plate.	103
3	070695	Screw-10-32X1/2 PHIL	4	Fastens bumper onto panel.	000
4	084549	Bumper	1	Protects grill from damage.	000
5	X73600-SER	Kit A.-Grease Shield	4	Fastens grease shields to rear shroud.	000
6	082959	Panel-Rear	1	Provides access to internal components for service and cleaning.	103
7	024298	Screw-10-32X3/8 SLTD Truss	54	Secures the panel to the frame.	000
8	084250	Panel-Side-Right	1	Provides access to internal components for service and cleaning.	103
9	078377-1	Caster-5 7-5/8 Stem	2	Allows grill mobility.	103
10	X84526	Can A.-Grease-R	1	Container for grease.	103
11	X84246	Shroud A.-Upper*RT	1	Metal bracket that the grease can slides into, securing it next to the lower grill plate.	103
12	073240-3	Caster-5 7-5/8 Stem-Swivel W/Lock	2	Prevents grill movement.	103
13	076989-WP	Switch-Rocker- DPST 10A	1	Activates power to the grill and the exhaust fans.	103
14	X84523	Door A.-Lower	1	Controls all functions of the grill.	---
15	X85623-SER	Touchscreen A.	1	Controls all functions of the grill.	---
16	068583	Cover A.-USB Waterproof	2	Protects USB port from water damage.	103
17	076012	Button-Operator- Black	2	Activates the cook cycle, keeps upper platen in the closed position, and displays the message STANDBY on the control. When pressed twice with one-second intervals between presses, the upper platen will automatically lower into STANDBY position.	000
18	076011	Button-Operator- Red	2	Cancels the Standby mode, raises the upper platen, and deactivates the Cook cycle.	000
19	X85465	Shield A.-Rear-GRS	2	Prevents grease migration.	000
20	084251	Panel-Side-Left	1	Provides access to internal components for service and cleaning.	103
21	084550	Bumper	1	Protects grill from damage.	000
22	086984	Outrigger A.-Right	1	Stabilizes grill.	000
23	086985	Outrigger-Left	1	Stabilizes grill.	000
24	087002	Pin-Cotter 1/8 x 1 in.	8	Secures the outrigger to the caster.	000
25	085441	Spacer Bumper	1	Protects grill from damage.	000



## C856 Exploded View

Item	Part No.	Description	Qty	Function	Warr. Class
1	X84971	Can A.-Grease-L	2	Container for grease.	103
2	X84248	Shroud A.-Upper*L	2	Metal bracket that the grease can slides into, securing it next to the lower grill plate.	103
3	070695	Screw-10-32X1/2 Phil	4	Fastens bumper onto panel.	000
4	084549	Bumper	1	Protects grill from damage.	000
5	X73600-SER	Kit A.-Grease Shield	4	Fastens grease shields to rear shroud.	000
6	084215	Panel-Rear	1	Provides access to internal components for service and cleaning.	103
7	024298	Screw-10-32X3/8 SLTD Truss	54	Secures the panel to the frame.	000
8	084250	Panel-Side-Right	1	Provides access to internal components for service and cleaning.	103
9	078377	Caster-5 7-5/8 Stem	2	Allows grill mobility.	103
10	X85465	Shield A.Rear GRS	2	Prevents grease migration.	
11	X84246	Shroud A.-Upper*R	2	Metal bracket that the grease can slides into, securing it next to the lower grill plate.	103
12	073240	Caster-5 7-5/8 Swivel W/Lock	2	Prevents grill movement.	103
13	X84526	Can A.-Grease-R	2	Container for grease.	103
14	076989-WP	Switch-Rocker- DPST 10A	1	Activates power to the grill and the exhaust fans.	103
15	X85623-SER	Touchscreen A.	2	Controls all functions of the grill.	- - -
16	X84504	Door A.-Welded	1	Houses the controls and the fan interlock switch.	103
17	068583	Cover A.-USB Waterproof	2	Protects USB port from water damage.	103
18	076012	Button-Operator- Black	2	Activates the cook cycle, keeps the upper platen in the closed position, and displays the message STANDBY on the control. When pressed twice with one-second intervals between presses, the upper platen will automatically lower into the Standby position.	000
19	076011	Button-Operator- Red	2	Cancels the Standby mode, raises the upper platen, and deactivates the Cook cycle.	000
20	084251	Panel-Side-Left	1	Provides access to internal components for service and cleaning.	103
21	084550	Bumper	1	Protects grill from damage.	000
22	085441	Spacer Bumper	1	Protects grill from damage.	000
23	033944	Screw-10-32x3/4 SLTD Truss	2	Secures the spacer to the bumper.	000
24	079150	Nut-10-32 Whiz Flange Nut	2	Secures the spacer to the bumper.	000

**C854/C856 Right Side View**

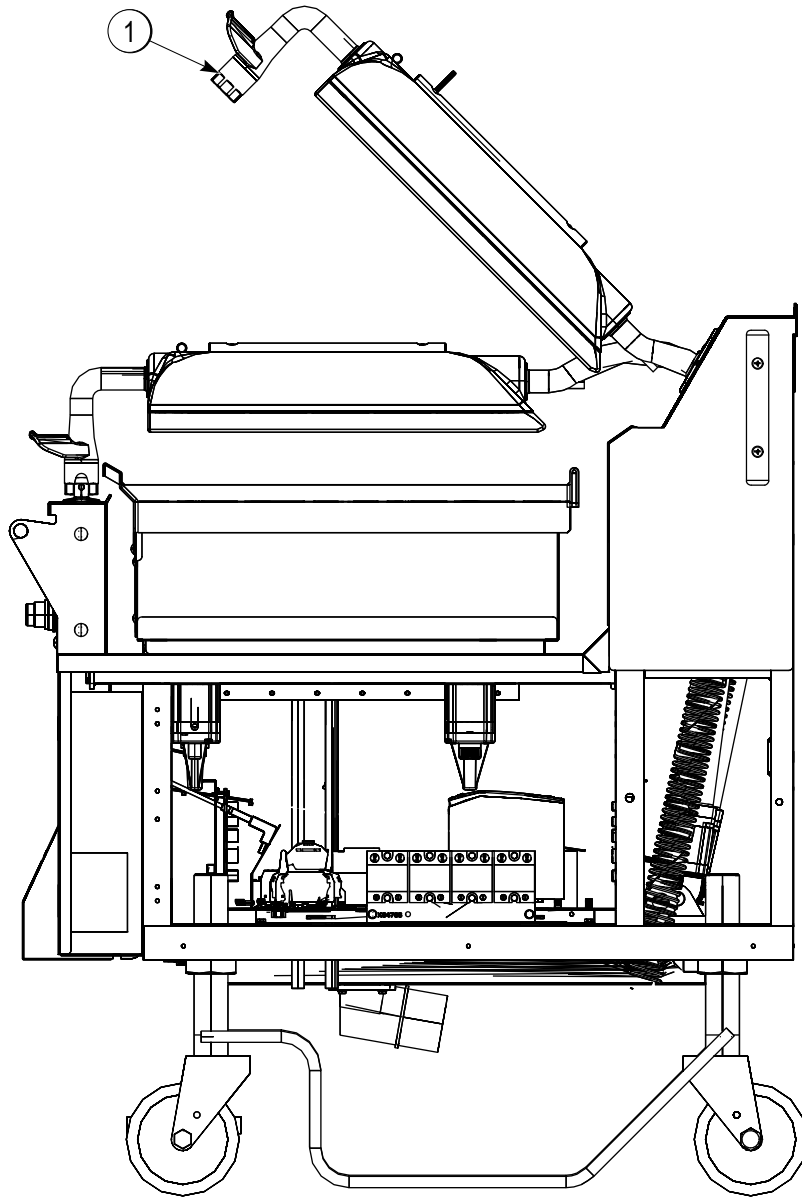

Figure-7 (C854 with outrigger shown)

Item	Part No.	Description	Qty.	Function	Warr. Class
1	X85716	Handle A.-Align Ring	1 (C854) 2 (C856)	The handle clicks in to the platen latch when in the down position.	103

**C854/C856 Left Side View**

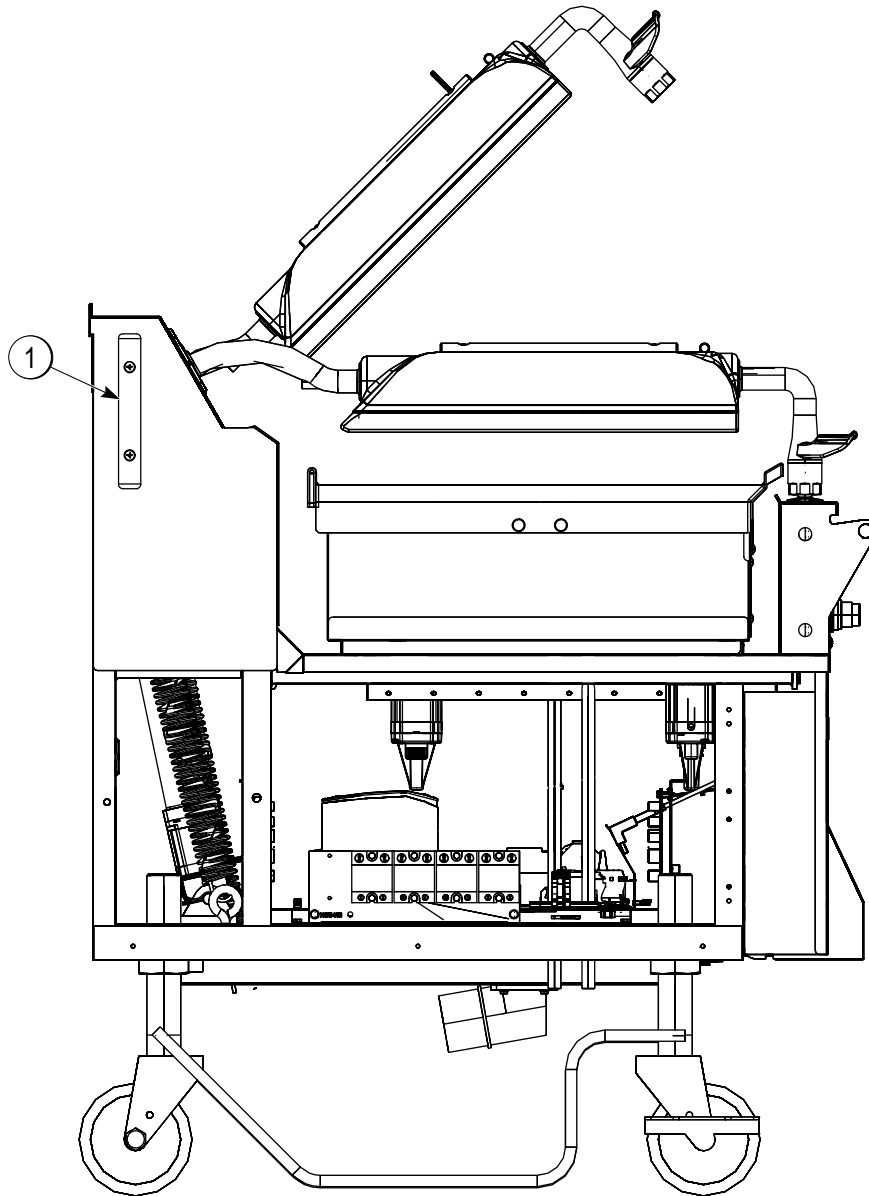

Figure-8 (C854 with outrigger shown)

Item	Part No.	Description	Qty.	Function	Warr. Class
1	084549	Bumper	1	Protects the grill from damage.	000

# C858 Exploded View

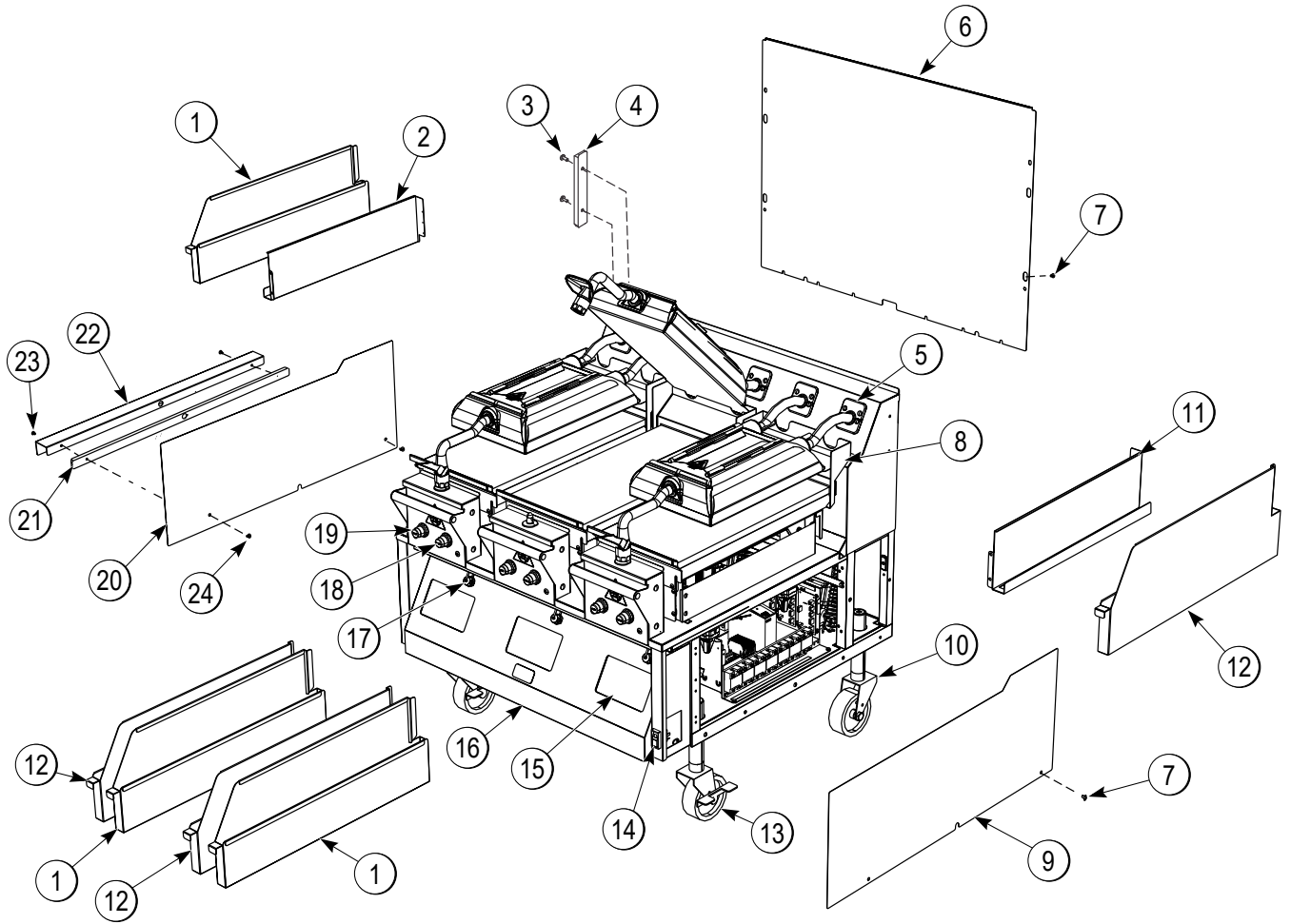

Figure-9

## C858 Exploded View

Item	Part No.	Description	Qty.	Function	Warr. Class
1	X84969	Can A.-Grease-L	3	Container for grease.	103
2	X84224	Shroud A.-Upper*L	3	Metal bracket that the grease can slides into, securing it next to the lower grill plate.	103
3	070695	Screw-10-32X1/2 Phil	4	Fastens bumper onto panel.	000
4	084549	Bumper	1	Protects grill from damage.	000
5	X73600-SER	Kit A.-Grease Shield	6	Fastens grease shields to rear shroud.	000
6	085963	Panel-Rear	1	Provides access to internal components for service and cleaning.	103
7	024298	Screw-10-32X3/8 SLTD Truss	54	Secures the panel to the frame.	000
8	X85465	Shield A.-Rear GRS	3	Prevents grease migration.	
9	082958	Panel-Side-Right	1	Provides access to internal components for service and cleaning.	103
10	078377	Caster-5 7-5/8 Stem	2	Allows grill mobility.	103
11	X84225	Shroud A.-Upper*R	3	Metal bracket that the grease can slides into, securing it next to the lower grill plate.	103
12	X84608	Can A.-Grease-R	3	Container for grease.	103
13	073240	Caster-5 7-5/8 Swivel W/Lock	2	Prevents grill movement.	103
14	076989-WP	Switch-Rocker- DPST 10A	1	Activates power to the grill and the exhaust fans.	103
15	X85623-SER	Touchscreen A.	3	Controls all functions of the grill.	---
16	X85931	Door A.-Welded	1	Houses controls and the fan interlock switch.	103
17	068583	Cover A.-USB Waterproof	3	Protects USB port from water damage.	103
18	076012	Button-Operator- Black	3	Activates the cook cycle, keeps the upper platen in the closed position, and displays the message STANDBY on the control. When pressed twice with one-second intervals between presses, the upper platen will automatically lower into the Standby position.	000
19	076011	Button-Operator- Red	3	Cancels the Standby mode, raises the upper platen, and deactivates the Cook cycle.	000
20	082957	Panel-Side-Left	1	Provides access to internal components for service and cleaning.	103
21	084613	Bumper	1	Protects grill from damage.	000
22	085447	Spacer Bumper	1	Protects grill from damage.	000
23	033944	Screw-10-32x3/4 SLTD Truss	2	Secures the spacer to the bumper.	000
24	079150	Nut-10-32 Whiz Flange Nut	2	Secures the spacer to the bumper.	000

# C860 Exploded View

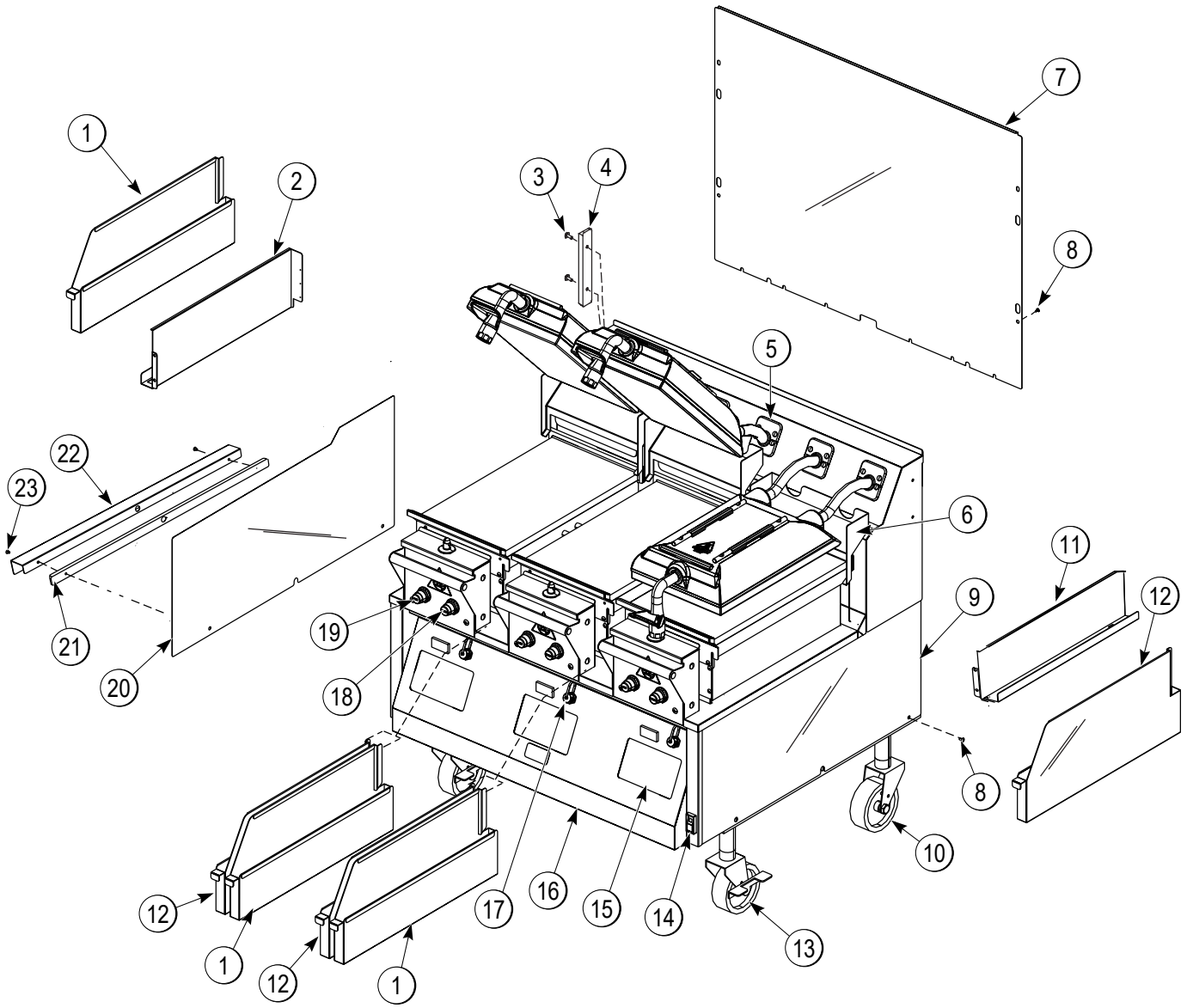

Figure-10

## C860 Exploded View

Item	Part No.	Description	Qty.	Function	Warr. Class
1	X84971	Can A.-Grease-L	3	Container for grease.	103
2	X84248	Shroud A.-Upper*L	3	Metal bracket that the grease can slides into, securing it next to the lower grill plate.	103
3	070695	Screw-10-32X1/2 Phil	4	Fastens bumper onto panel.	000
4	084549	Bumper	1	Protects grill from damage.	000
5	X73600-SER	Kit A.-Grease Shield	6	Fastens grease shields to rear shroud.	000
6	X85465	Shield A.-Rear GRS	3	Prevents grease migration.	
7	085963	Panel-Rear	1	Provides access to internal components for service and cleaning.	103
8	024298	Screw-10-32X3/8 SLTD Truss	54	Secures the panel to the frame.	000
9	084250	Panel-Side-Right	1	Provides access to internal components for service and cleaning.	103
10	078377	Caster-5 7-5/8 Stem	2	Allows grill mobility.	103
11	X84246	Shroud A.-Upper*R	3	Metal bracket that the grease can slides into, securing it next to the lower grill plate.	103
12	X84526	Can A.-Grease-R	3	Container for grease.	103
13	073240	Caster-5 7-5/8 Swivel W/Lock	2	Prevents grill movement.	103
14	076989-WP	Switch-Rocker- DPST 10A	1	Activates power to the grill and the exhaust fans.	103
15	X85623-SER	Touchscreen A.	3	Controls all functions of the grill.	- - -
16	X85761	Door A.-Welded	1	Houses controls and the fan interlock switch.	103
17	068583	Cover A.-USB Waterproof	3	Protects USB port from water damage.	103
18	076012	Button-Operator- Black	3	Activates the cook cycle, keeps the upper platen in the closed position, and displays the message STANDBY on the control. When pressed twice with one-second intervals between presses, the upper platen will automatically lower into the STANDBY position.	000
19	076011	Button-Operator- Red	3	Cancels the Standby mode, raises the upper platen, and deactivates the Cook cycle.	000
20	084251	Panel-Side-Left	1	Provides access to internal components for service and cleaning.	103
21	084613	Bumper	1	Protects grill from damage.	000
22	085447	Spacer Bumper	1	Protects grill from damage.	000
23	033944	Screw-10-32x3/4 SLTD Truss	2	Secures the spacer to the bumper.	000

# C858 Right Side View

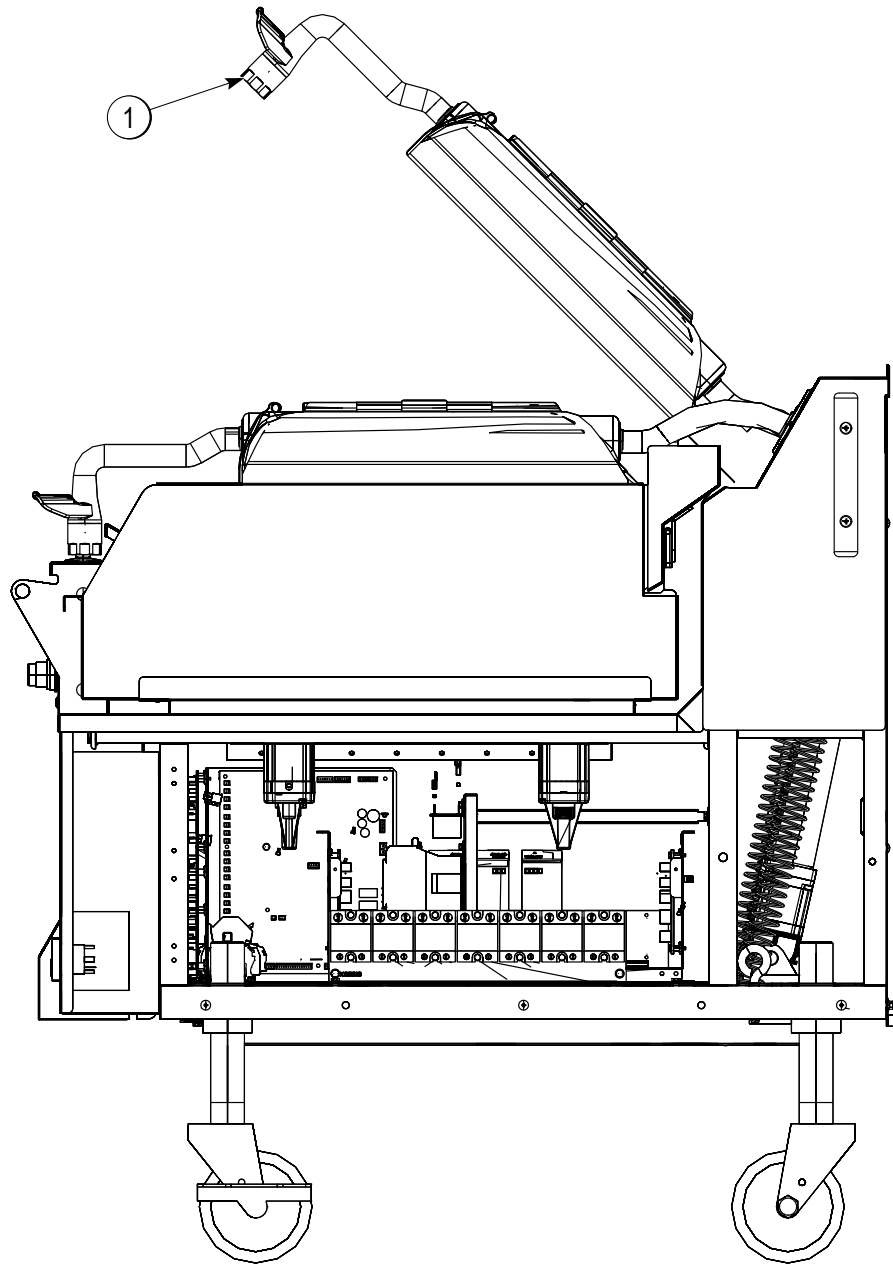

Figure-11

Item	Part No.	Description	Qty.	Function	Warr. Class
1	X85715	Handle A.-Align Ring	3	The handle clicks in to the platen latch when in the down position.	103

**C858 Left Side View**

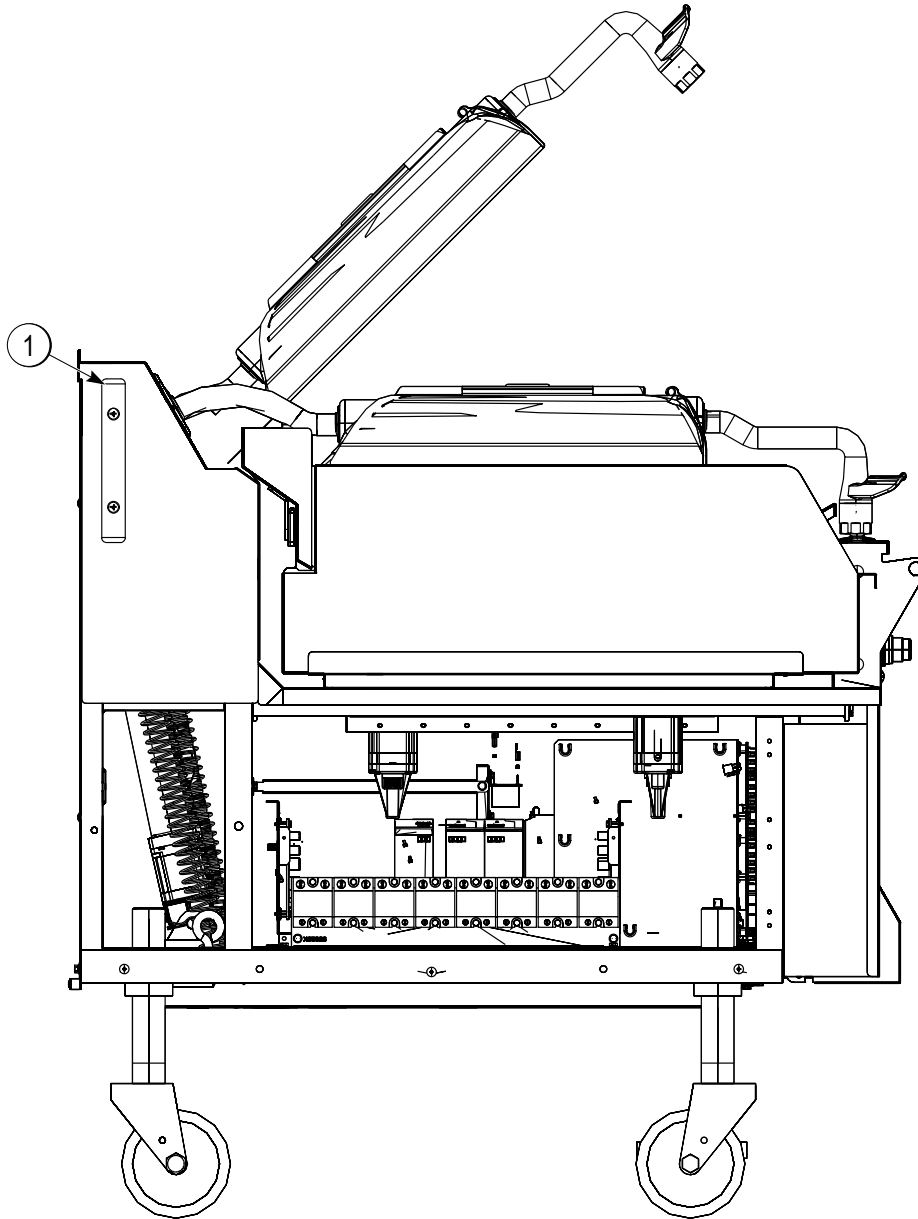

Figure-12

Item	Part No.	Description	Qty.	Function	Warr. Class
1	084549	Bumper	1	Protects the grill from damage.	000

# C860 Right Side View

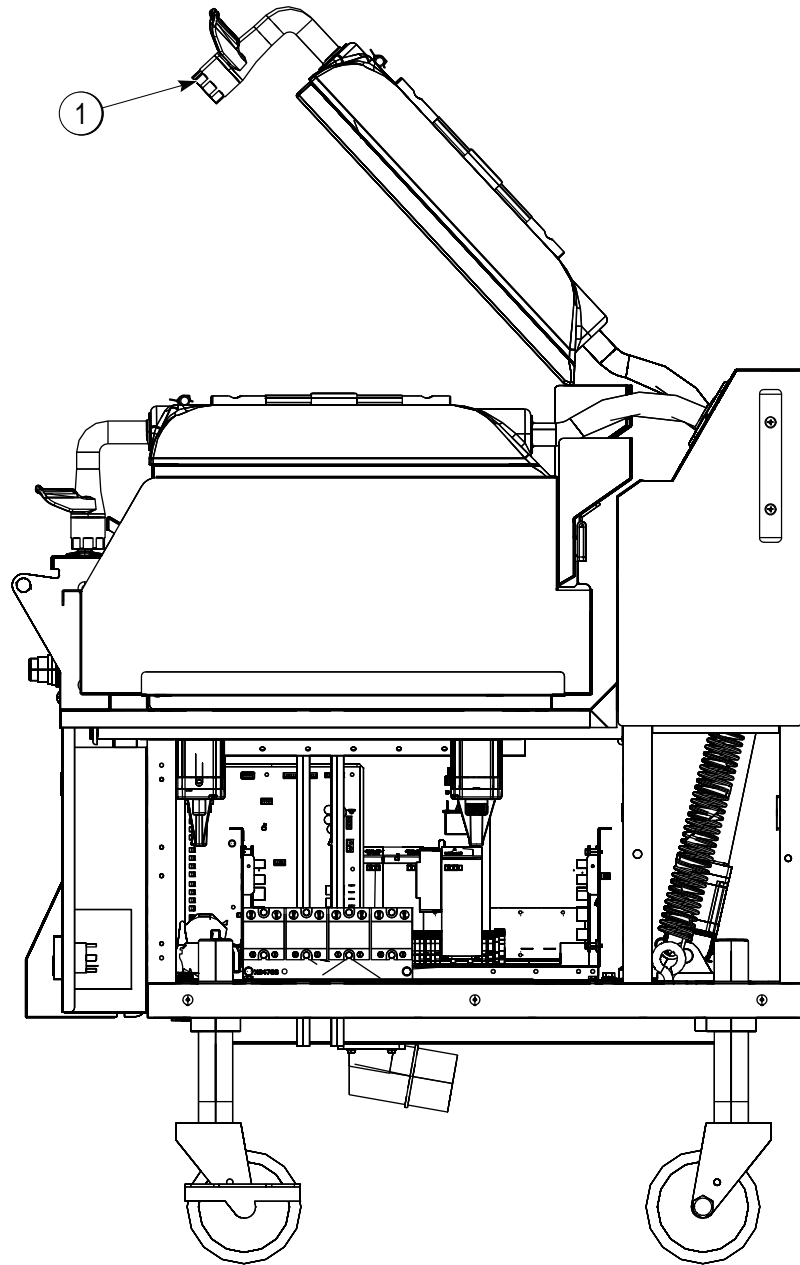

Figure-13

Item	Part No.	Description	Qty.	Function	Warr. Class
1	X85715	Handle A.-Align Ring	3	The handle clicks in to the platen latch when in the down position.	103

**C860 Left Side View**

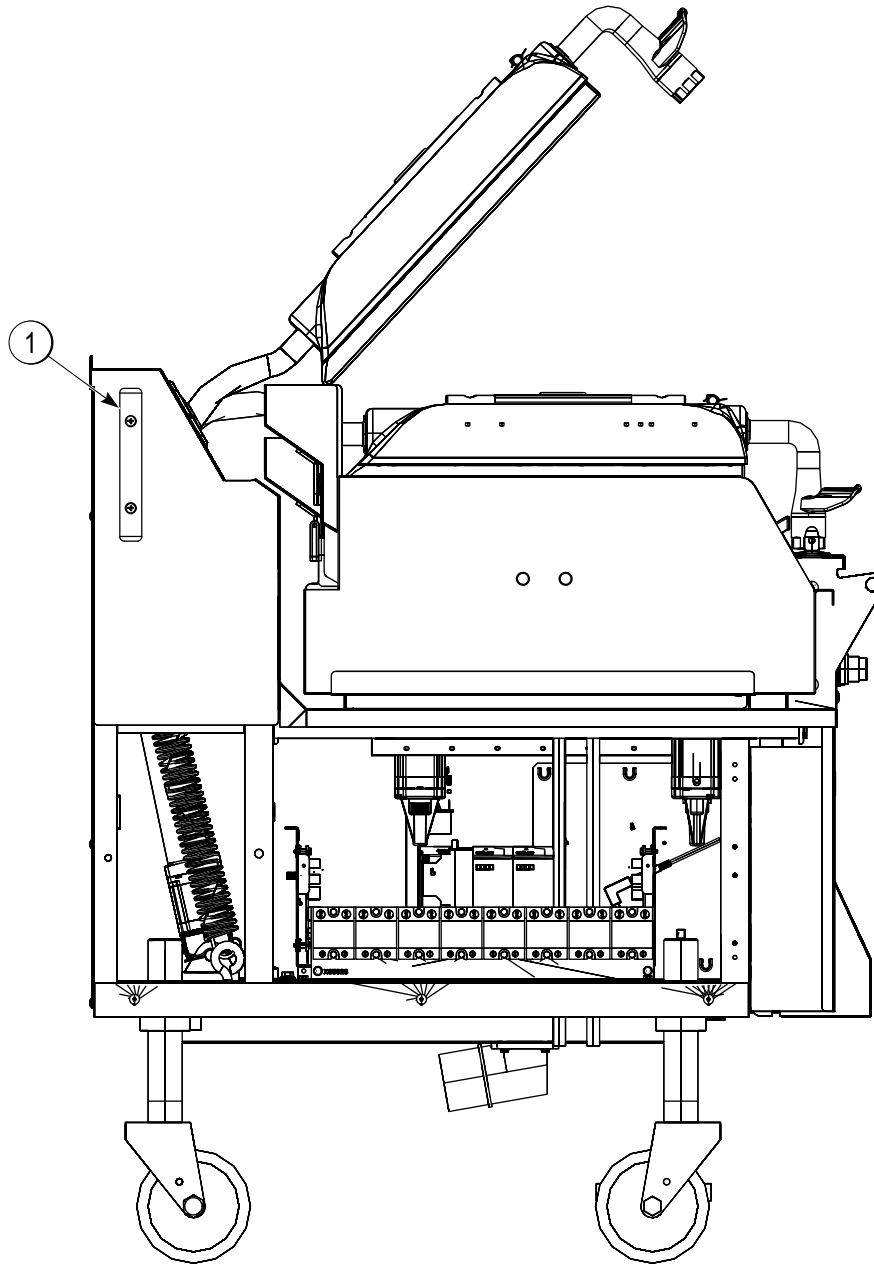

Figure-14

Item	Part No.	Description	Qty.	Function	Warr. Class
1	084549	Bumper	1	Protects the grill from damage.	000

## Accessories

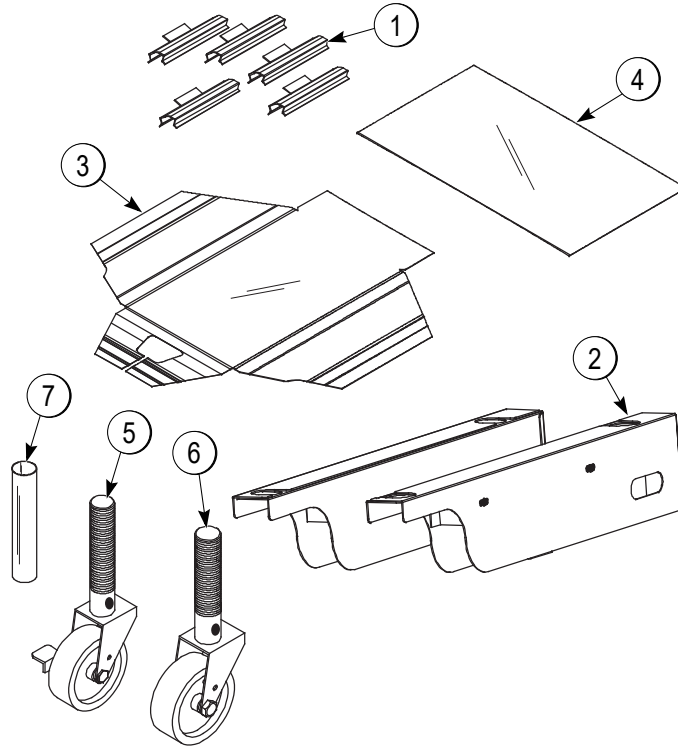

Figure-15

Item	Part No.	Description	Function	Warr. Class
1	072673	Clip-Release Material-w/Tab	Secures the release material to the front and sides of the platen.	000
*2	X85752	Kit A.-Caster Guard (C850)	Protects the power cord.	000
	X85753	Kit A.-Caster Guard (C852/C858)	Protects the power cord.	000
	X85754	Kit A.-Caster Guard (C854)	Protects the power cord.	000
	X85756	Kit A.-Caster Guard (C856/C860)	Protects the power cord.	000
3	084366	Sheet-Release Box of 3	Non-stick barrier used to protect the upper platen.	000
**4	084387	Sheet-Lower Release Box of 3	Non-stick barrier used to protect the lower cook surface.	000
5	073240-3	Caster-5" 7-5/8 Swivel W/Lock (C850/C854 Only)	Prevents grill movement.	000
	073240	Caster-5" 7-5/8 Swivel W/Lock (C852/C856/C858/C860)	Prevents grill movement.	000
6	078377-1	Caster-5" 7-5/8 Stem Rigid (C850/C854)	Allows grill mobility.	000
	078377	Caster-5" 7-5/8 Stem Rigid (C852/C856/C858/C860)	Allows grill mobility.	000
7	084814	Cover-Caster Thread (C850/C854)	Protects the caster thread.	000

\*Optional–Purchased separately

\*\*For markets using lower release sheets only.

# IMPORTANT TO THE OPERATOR

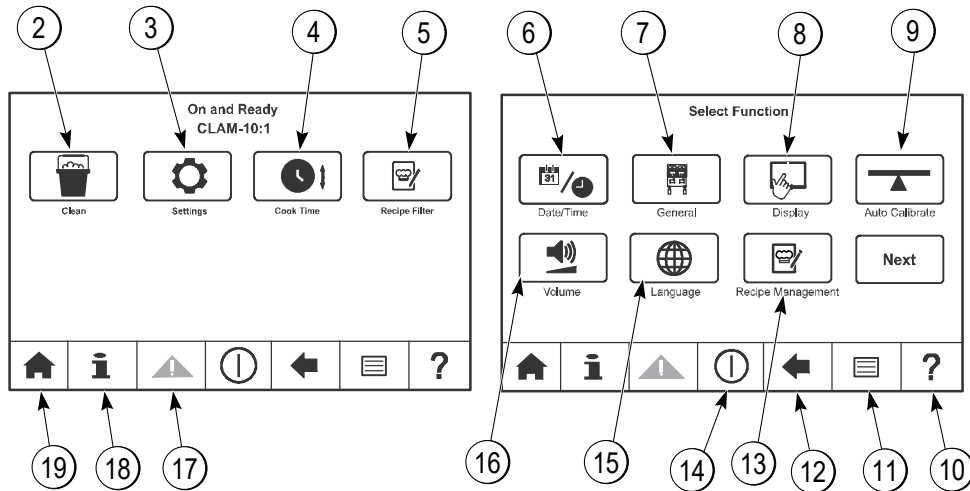
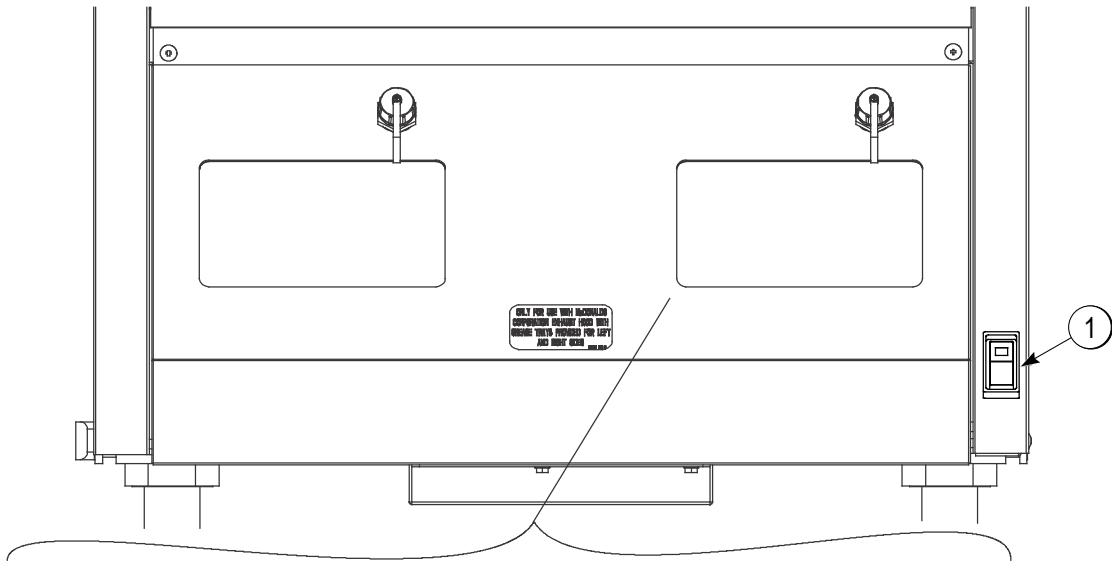

Crew Menu Touchscreen

Manager's Menu Touchscreen

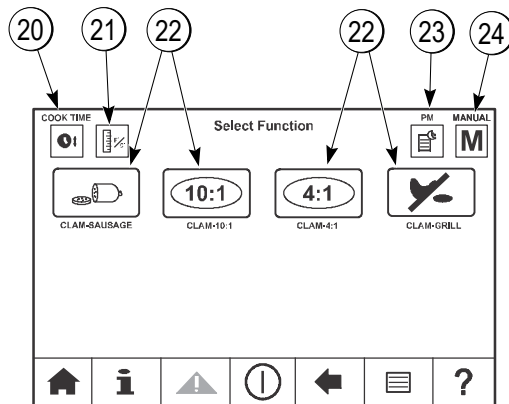

Home Menu Touchscreen

Figure-16

## Important to the Operator Exploded View

Item	Description	Function
1	Fan Interlock Switch	Activates power to the grill and the exhaust fans.
2	Clean Key	Takes the grill into the ready mode for cleaning.
3	Settings Key	Displays a passcode screen to allow the manager to enter the passcode and enter the Manager menu. From the Manager menu, the manager can make adjustments to the Date/Time, Temperature Scale, Volume, Brightness, Language, and Firmware Manager functions.
4	Cook Time Key	Allows the user to set the Cook Time.
5	Recipe Filter Key	Allows the user to choose the grill mode (auto or manual) and toggle between AM, PM, and ALLDAY modes.
6	Date/Time Key	Allows the user to enter the date and time of day.
7	General Key	Displays the Temperature Scale, Firmware, and About screens.
8	Display Key	Displays the Brightness and Font Limit screens.
9	Auto Calibrate Key	Allows the user to Auto Calibrate and Gap Check.
10	Help Key	Future development
11	Menu Key	Displays the main screen.
12	Back Arrow Key	Returns the user to the previous screen.
13	Recipe Management Key	Allows the user to choose a product.
14	Power Key	Takes the user to another screen to turn the grill controller off.
15	Language Key	Selects the desired language.
16	Volume Key	Selects the desired volume.
17	Notification/Warning Key	Displays the recent faults and events.
18	Information Key	Displays current status of machine (examples: temperatures of upper platens and lower cook surfaces, date when last cleaning was performed).
19	Home Key	Enters the main menu.
20	Cook Time Shortcut Key	Allows the user to jump to the Cook Time key from the Home screen.
21	Temperature Calibration Key	Allows the user to calibrate temperatures of specified areas on the grill.
22	Recipe Key	Allows the user to choose a product.
23	AM/PM Shortcut Key	Allows the user to jump to the AM/PM key from the Home screen.
24	Manual Shortcut Key	Allows the user to jump to the Manual key from the Home screen.

## Other Symbol Definitions

To better communicate in the international arena, the words on many of our operator keys have been replaced by symbols to indicate their functions. Your Taylor equipment is designed with these international symbols.

The following chart identifies the symbol definitions.



= ON Key—Activates and deactivates the grill control.



= Home Key—Returns you to the actions required screen.



= Information Key—Displays the current status of machine (examples: temperatures of upper platens and lower cook surfaces, date when the last cleaning was performed, and date when the last product integrity was performed.)



= Notification Key (grey)—No active alert or warning.



= Warning Key (orange)—Displays the recent faults and events.



= Alarm Key (red)—Displays the recent faults and events. Highest level of concern.



= Notification Key (yellow)—Displays the recent faults and events. Concerns that are not urgent.



= Alert Key (red)—Displays the recent faults and events. Highest level of concern.



= Back Arrow Key—Returns the user to the previous screen.



= Help Key—Content details of current screen. - Future development



= Menu Key—Displays list of available actions in the grill.



= Checkmark Key—Acknowledges the changes completed.



= (Full) Clean Key—Takes the grill into the ready mode for cleaning.



= Auto Calibrate Key—Allows the user to auto Calibrate and Gap Check.



= Settings Key—Displays a passcode screen to allow the manager to enter the passcode and enter the Manager menu. From the Manager menu, the manager can make adjustments to the Date/Time, Temperature, Scale, Volume, Brightness, Language, and Firmware Manager functions.



= Training Key—Displays steps on how to perform various actions.



= About Key—Displays information regarding model, bill of material, Store I.D., and IP address.



= Date/Time Key—Allows the user to enter the date and time of day.



= Date Key—Displays the current date.



= Time Key—Actual time is displayed and allows the user to update the time.



= Scale Key—Allows the user to select Celsius or Fahrenheit.



= Celsius Key—Display will be blue if in Celsius format.



= Fahrenheit Key—Display will be blue if in Fahrenheit format.



= Not Calibrated Key

## Other Symbol Definitions



= X Key–Do not save current changes. Exits current screen.



= Auto Calibrate Key–Pressing this key will calibrate the gaps. Also in Info screen displaying status.



= Grill Mode Key–Allows the user to toggle between Manual and Auto. Also represents the Manual Mode.



= Firmware Manager Key–Allows the user to update software.



= Brightness Key–Displays the current brightness setting and allows the user to change the brightness level.



= Gap Check Key–Moves the lower platen to a defined gap.



= Recipes Key–Functions associated with recipes.



= Display Key–Displays the Brightness and Font Limit screens.



= Volume Key–Sets the desired volume.



= Language Key–Displays the available languages.



= Cook Time Key–Allows the user to set the cooking time for the product.



= Configuration Key–Allows the user to change the default settings.



= AM/PM Key–Allows the user to toggle between AM and PM mode.



= General Key–Allows updates to software, viewing/updating the config. Also used in Info. Screen for temp. In grill.



= Recipe Filter Key–Allows the user to choose the grill mode (Manual/Auto) and toggle between AM, P,M and ALLDAY.



= Recipe Management Key–Allows the user to toggle, change the order of recipes, and make other changes to recipes.



= Copy From Key–Allows the user to download recipes and other information to the grill from a USB drive.



= Copy To Key–Allows the user to upload recipes and other information to a USB drive from the grill.



= Auto Key–Sets the grill to automatically detect product placed on the grill and sets the proper cooking parameters.



= Font Limits Key–Allows the user to change the font size.



= Seconds Only Key–Allows the user to change the Countdown Timer from seconds only to minutes and seconds.



= Status Indicator Key–Shows the operator the overall health of the grill.



= Recovery Key–Allows the user to enter the Recovery Mode in the Clean menu.



= All Day Key–Allows the user to store recipes that can be used all day.



= Wipe Down Key–Allows the lower plate to be lowered for cleaning without lowering the temperature of the plate.



= Time Format Key–Allows the user to choose either the 12- or 24-hour format.



= Next Key–Advances the user to the next screen.



## EQUIPMENT SETUP AND CLOSE PROCEDURES

The two-platen Model C852 has been selected to illustrate the step-by-step procedures in this manual. For grills equipped with less than two platens, perform the following steps as appropriate for your grill platen configuration.

### Installing Upper Platen Release Sheets

1. Carefully wrap the release sheet side flaps over the side cover rails. Secure the sheet with the locking clips. The back edge of the sheet will not be secured, but instead will hang free. See Figure 17.

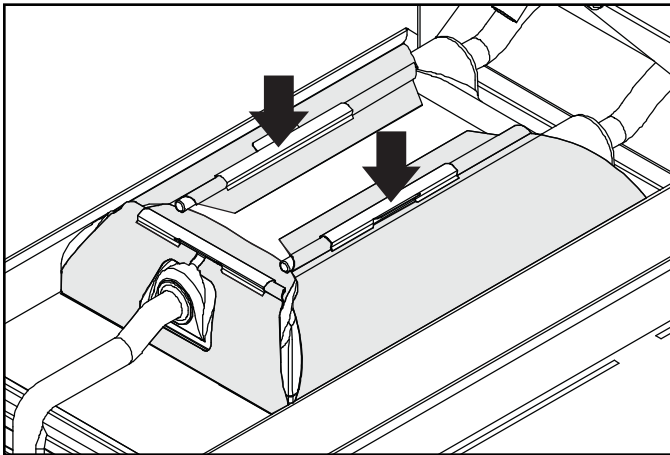

Figure-17

2. Center the release sheet on the front of the upper platen. Pull it tightly over the release material cover rail located in the front of the platen and secure it with a locking clip. See Figure 18.

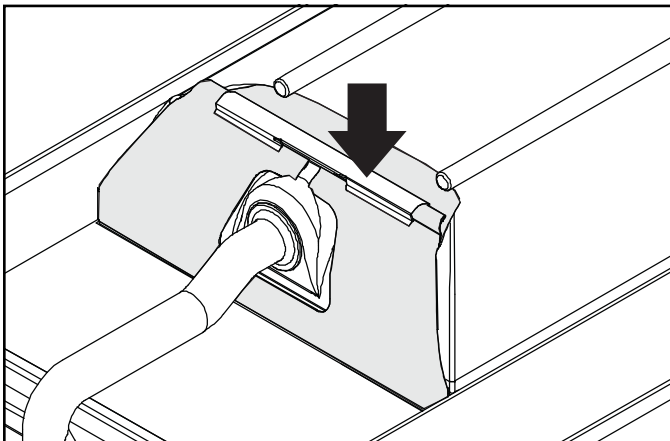

Figure-18

**Important!** Do not crease the release sheet. This will greatly reduce the life of the sheet.

3. Make sure the release sheets are tight across the upper platen surface.

4. Repeat step 1 through step 3 for the other upper platen on Models C852, C856, and C858.

### Changing Release Sheets

**The release sheet must be changed when:**

- Product sticks to the release sheet.
- Carbon builds up, causing problems in taste or appearance.
- There is a tear in the release sheet in the cooking area.
- The release material substance is worn from the release sheet.

**Note:** Reverse the cooking side of the release sheets on a daily basis (example: black side on odd days; grey or brown side on even days).

### Proper Care for Release Sheets

- Do not fold or crease.
- Do not touch with any sharp object or abrasive.
- Do not hose with hot water or soak in water.
- Do not place under other objects.

### Startup Grill

**Important!** The lower grill plate and the upper platen must be clean before starting these procedures.

**Note:** Grills that use lower release sheets require startup of grill before installation of lower release sheets.

1. Place the fan interlock switch in the ON position. The controller will initialize and then display the following screen. See Figure 19.

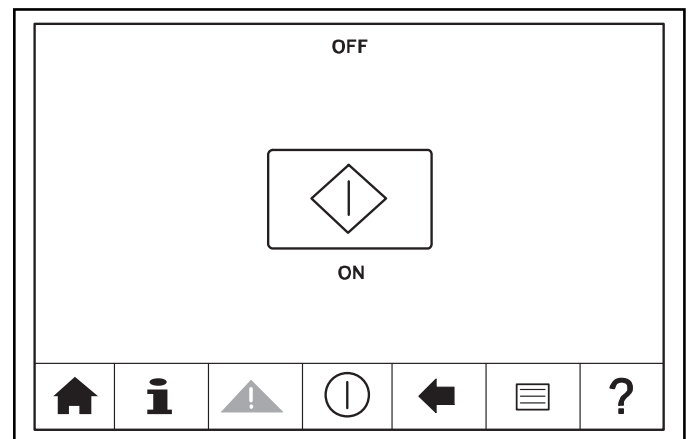



Figure-19

- If the alert key  is any color other than gray, an error has occurred. Refer to the screen for instructions.
- Pressing the on key  will display the heat up timer. See Figure 20.

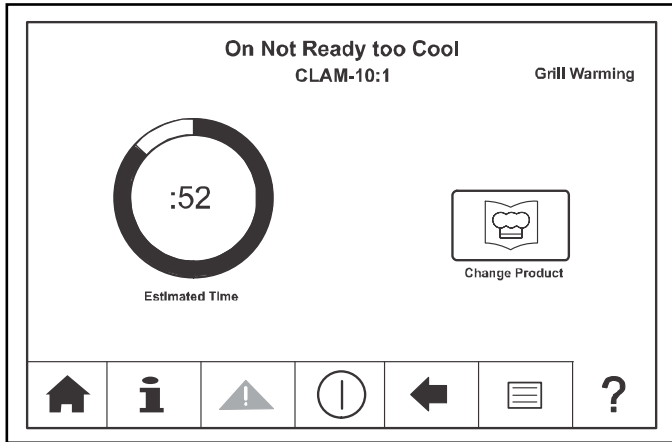



Figure-20

- This timer will remain in place until the grill reaches set point.

**Note:** The current product is displayed on the On Not Ready too Cool screen. If the selected product needs to change, press the Change Product

key . This will display the available recipe items that can be selected. See Figure 21.

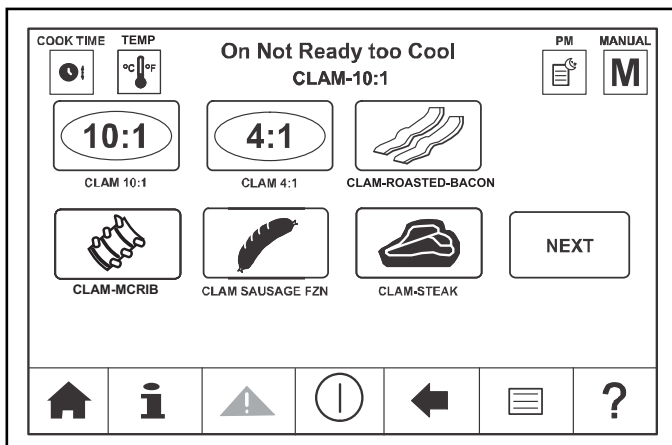

Figure-21

- If a product is not selected within 10 seconds, the screen will go back to the heat up/cool down timer.

- Once the grill reaches the desired set point, the auto calibration screen will appear for 40 seconds and then close. The screen will then display the following. See Figure 22.

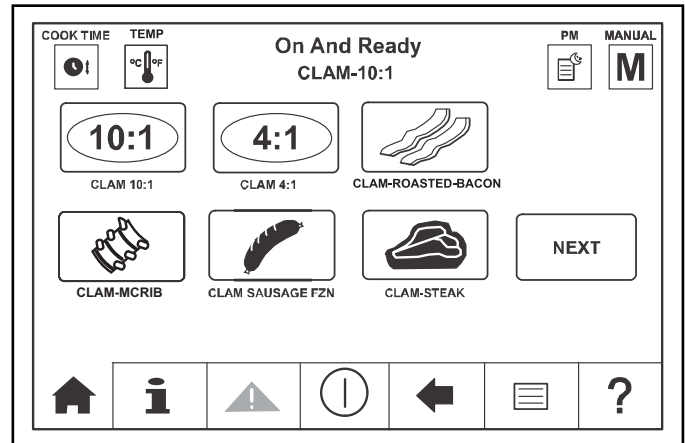



Figure-22

- Press the menu key  to display the menu screen. See Figure 23.

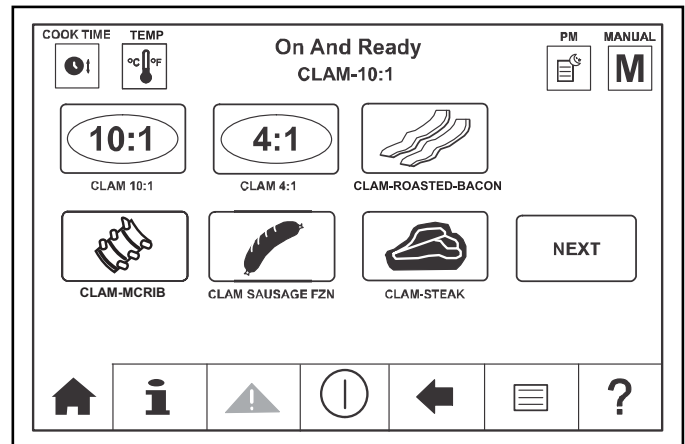

Figure-23

- The menu screen appears below. See Figure 24.

- Press the Clean key .

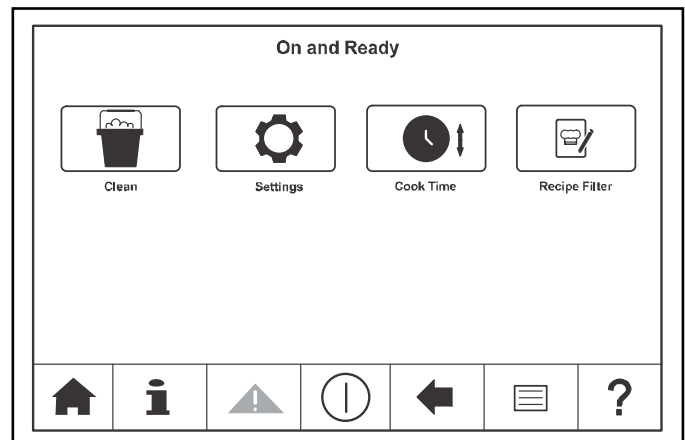



Figure-24

10. Selecting the Clean key  will allow the operator to select the clean option. See Figure 25.

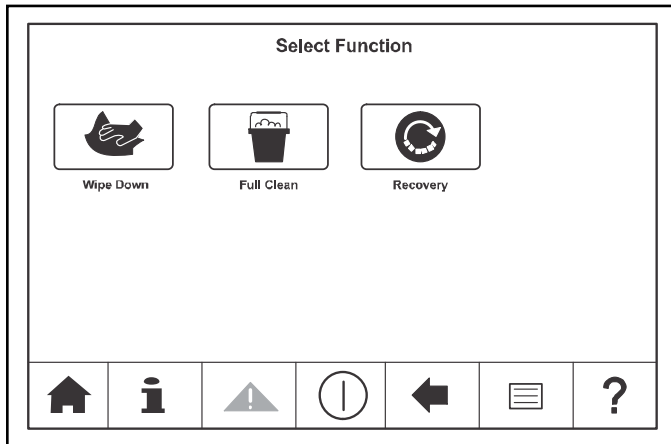



Figure-25

11. Select the Settings key  to enter the Manager Menu. See Figure 26.

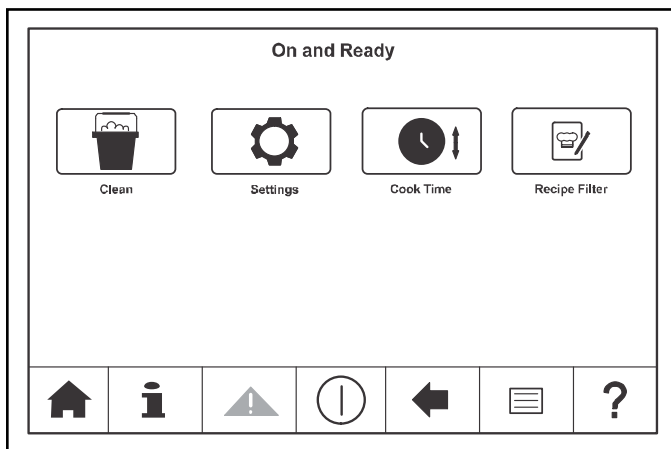

Figure-26

12. Enter the manager menu passcode 1955. See Figure 27. (See page 38 for more details.)

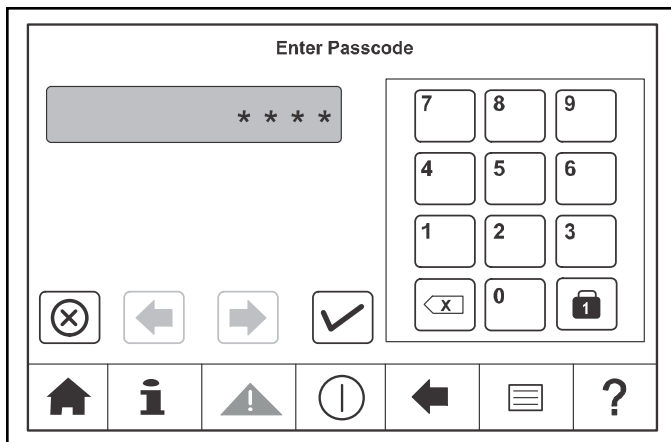



Figure-27

13. Select the Cook Time key . See Figure 28.

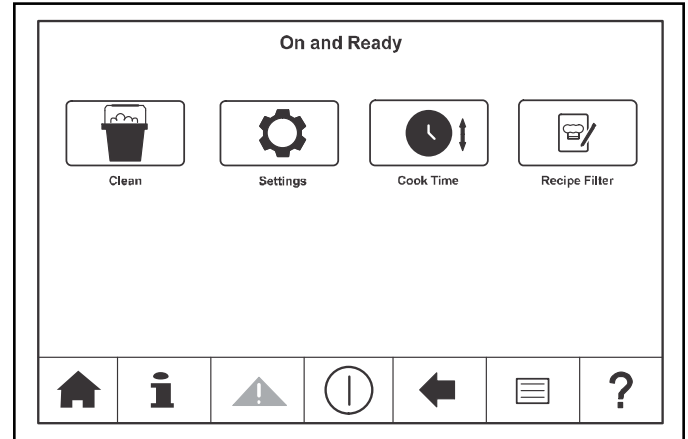



Figure-28

14. If the cook time is correct, press the checkmark key  to confirm. See Figure 29.

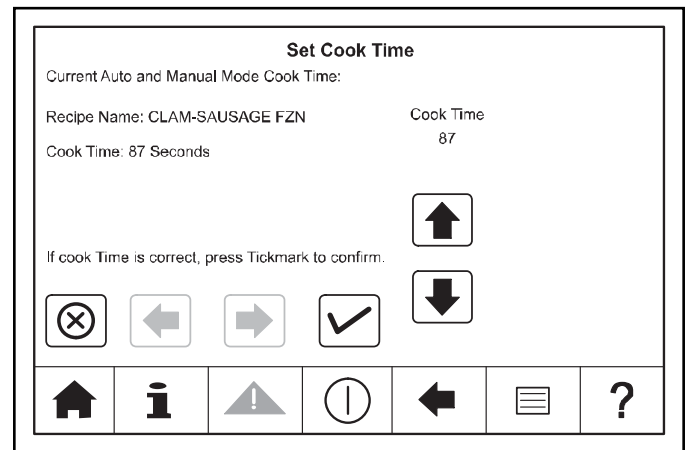

Figure-29

15. Select the Recipe Filter key . See Figure 30.

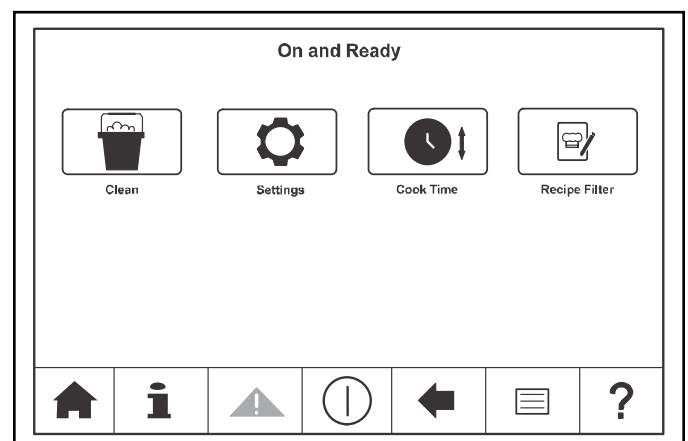

Figure-30

16. Choose Grill Mode (see page 43 for more information) or AM/PM Toggle. See Figure 31.

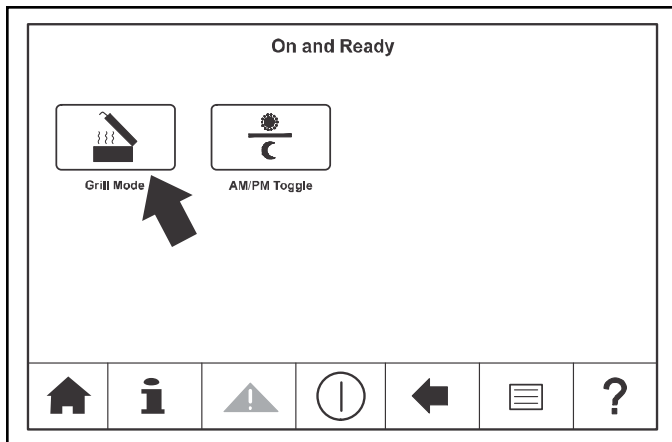

Figure-31

17. Choose AM, PM, or ALL DAY. See Figure 32.

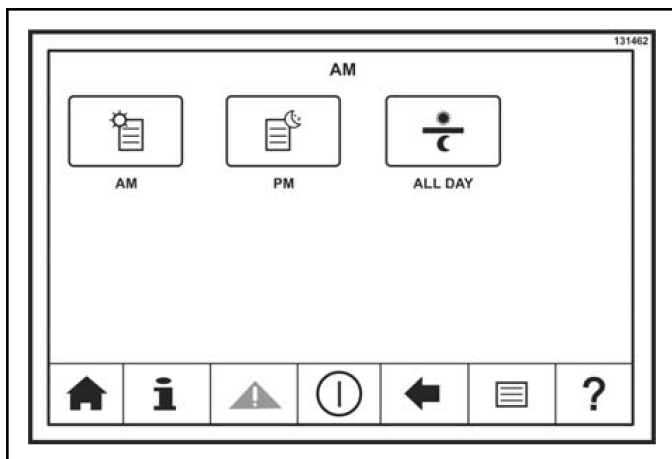

Figure-32

### Installing Lower Release Sheets

**Note:** The following steps pertain only to grill markets using lower release sheets. If lower release sheets are not used, please disregard this procedure.



**IMPORTANT!** Upper release sheets cannot be used on the lower grill surface. Poor quality and potential food safety issues will occur.

1. Put on heat-resistant gloves. See Figure 33.

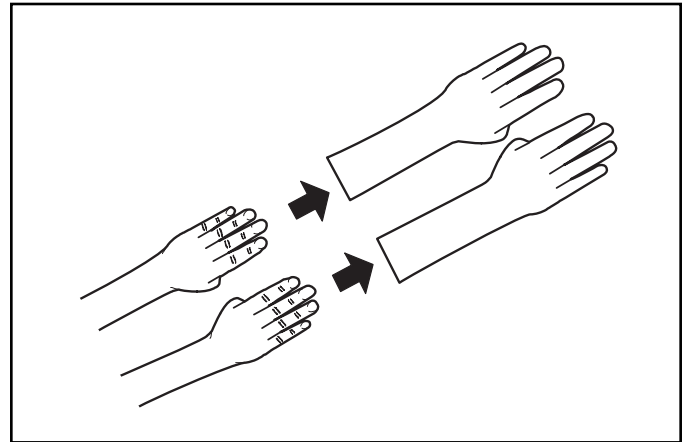

Figure-33

2. Clean the grill with a sanitizer-soaked grill cloth to remove any debris on the grill. See Figure 34.

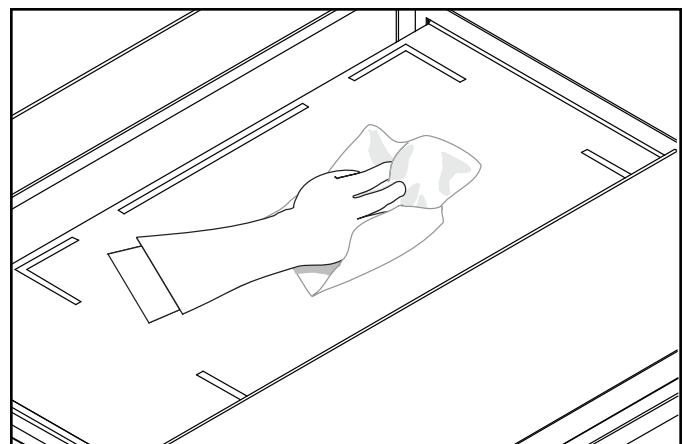

Figure-34

3. Using a sundae spoon, distribute two level spoonfuls of soy adhesion flakes over one warm 12 in. (305 mm) cook zone, and allow the flakes to melt. See Figure 35.

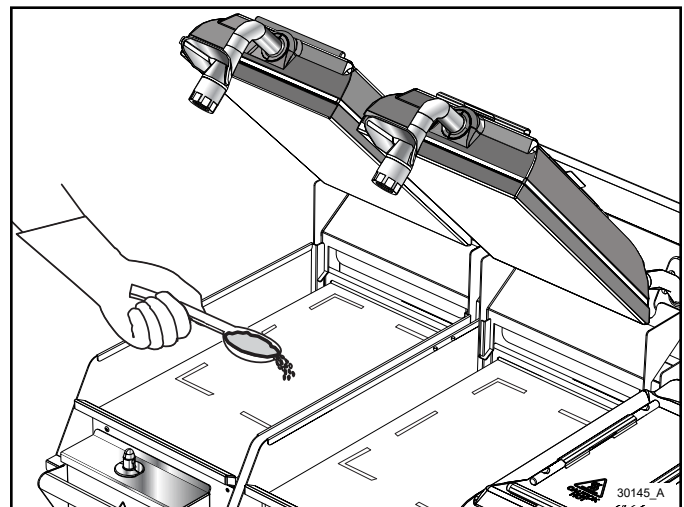

Figure-35

- Using a clean squeegee, spread the flakes on the cooking zone. See Figure 36.

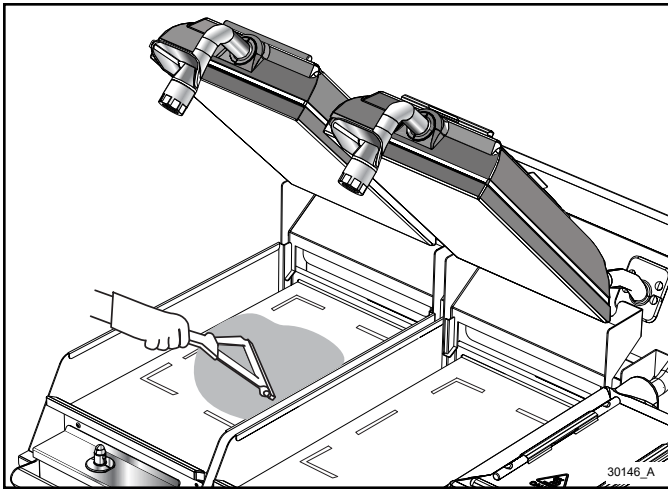

Figure-36

- With the 12 in. (305 mm) side of the lower release sheet facing the back of the grill, hold the release sheet about one inch from the end of each side. Align the back edge of the release sheet with the back splash and the side edge of the grill. See Figure 37.

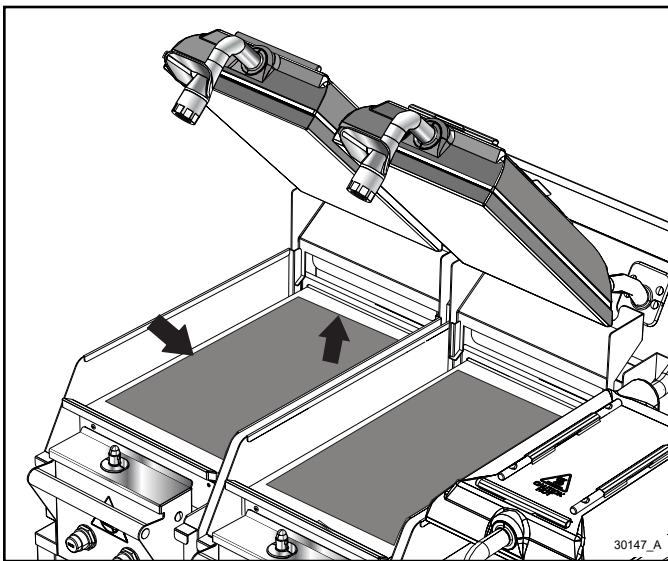

Figure-37

- Using the grill squeegee, gently squeegee out the air bubbles, making sure not to crease or fold the release sheet. See Figure 38.

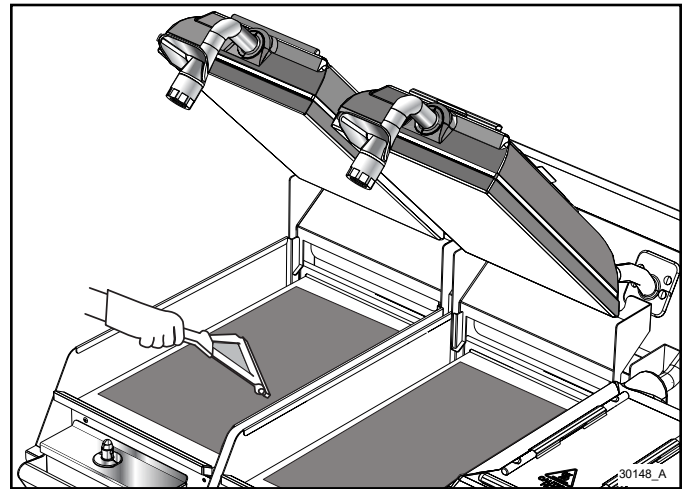

Figure-38

- Repeat step 5 and step 6 for the other cook zone if applicable.

**Note:** When properly applied, the release sheet will lie flat, with only a few small air bubbles.



## MENU SCREENS

**Note:** For all screens that display the checkmark key

☑ and the X key ⊗; pressing the checkmark key saves the selection and exits the screen. Pressing the X key exits the screen without saving the selection.

At the bottom of the main menu screen the following keys are displayed:

- Home Key** 🏠 : Enters the cooking settings menu.
- Information Key** ⓘ : Displays the current status screen and the following information.
  - Displays the current grill temperatures for the upper and lower platens, in addition to the ambient temperature of the control board.
- Alert Key** ⚠ : Displays the recent faults and events.
- Power/On/Off Key** ⏻ : Activates/deactivates the grill control.
- Back Arrow Key** ⬅ : Returns the user to the previous screen.

- **Menu Key**  : Displays the production menu screen.
- **Help Key**  : Contains details of the current screen and future development.

**Note:** See “Cooking Product” starting on page 43 for detailed information on the use of these keys.

### Manager Menu—Passcode Access

Additional access to menu screens is available through the manager menu.

To access the manager menu, press the settings key

 . The passcode screen will display. See Figure 39.

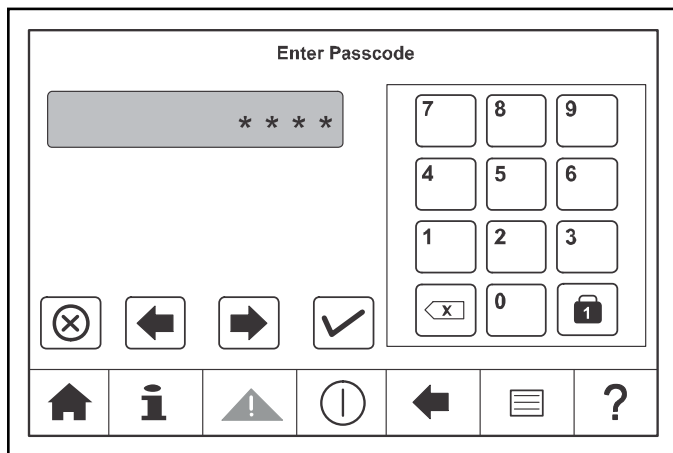



Figure-39

Enter the manager menu pass code 1955 and press the checkmark key  . The Select Function screen will display. See Figure 40

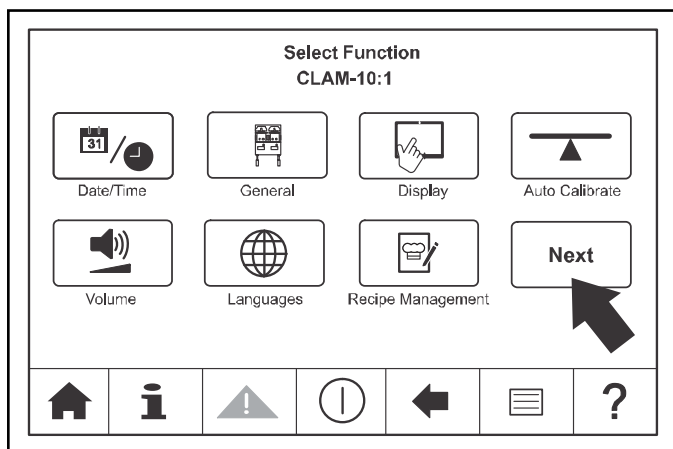

Figure-40

Press Next key to see the second screen. See Figure 41.

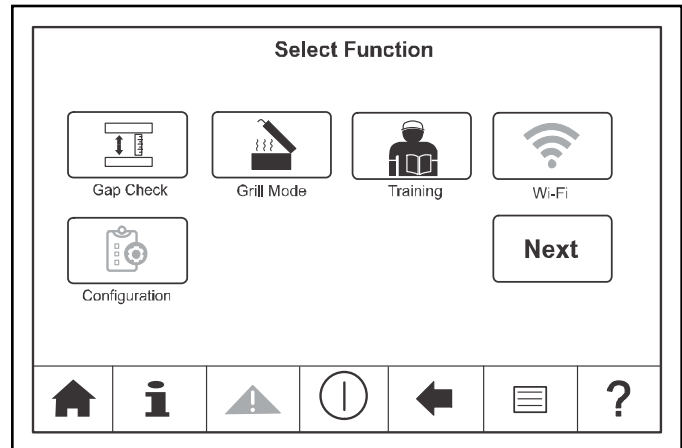



Figure-41

## Auto Calibrate Key

Use as needed. Troubleshooting Guide on page 77.

Press the Auto Calibrate key  to initiate auto calibration. See Figure 42, Figure 43, and Figure 44.

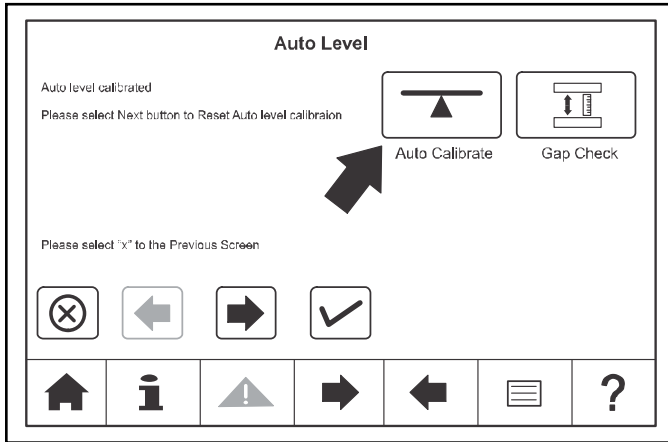

Figure-42

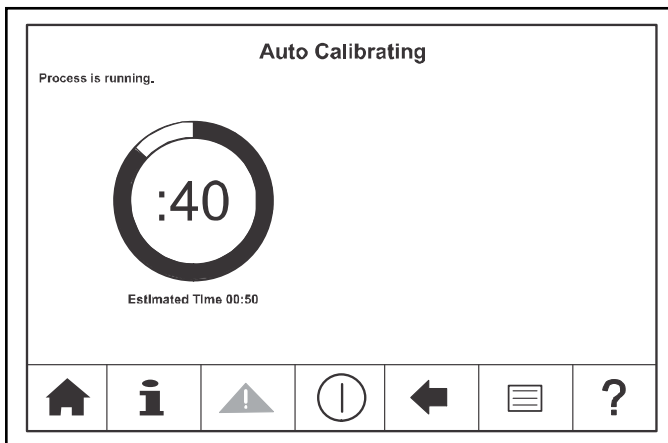

Figure-43

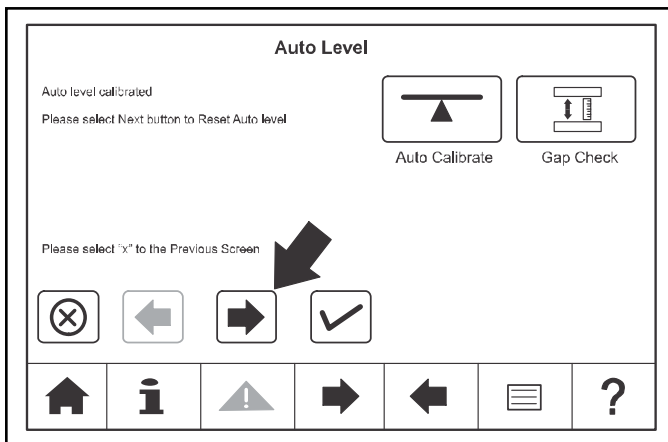



Figure-44

## Date/Time Key

The date/time screen is used to enter the date and time of day. When the Date/Time key  is pressed, three keys are displayed. The Date key, the Time key, and the Date/Time Format key. See Figure 45.

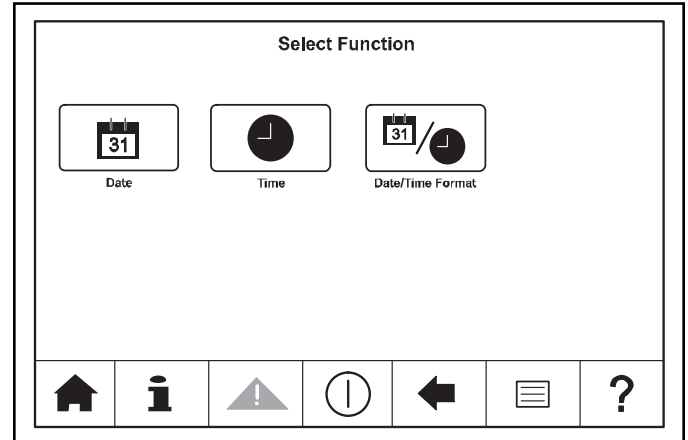





Figure-45

To enter the date, press the Date key . Enter the year, month, and day, using the up and down arrow keys.

Press the checkmark key  to confirm the selection or press the X key  to return to the Select Function screen without saving the selection. See Figure 46.

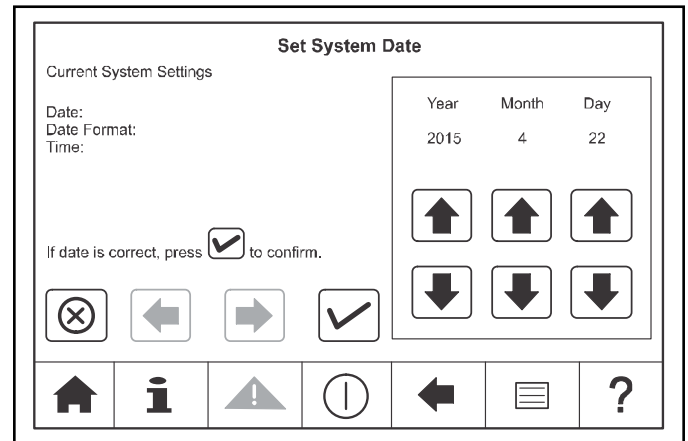



Figure-46

To enter the time, press the Time key . Enter the hour, minute, and AM/PM, using the up and down arrow keys. Press the checkmark key  to confirm the selection. See Figure 47.

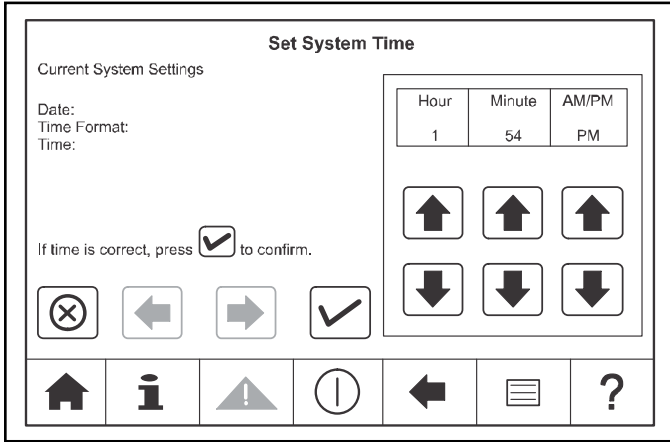







Figure-47

Next, press the Time Format key . Turn the daylight savings time and 24 hour clock on or off, as needed and press the checkmark key  to confirm the selections.

Press the back arrow key  to return to the Select Function screen.

## Scale Key

The scale screen is used to select the temperature scale to be used, either Celsius or Fahrenheit. When the scale key  is pressed, two keys are displayed;  and . Press the desired temperature scale key. Press the back arrow key to return to the Select Function screen. See Figure 48.

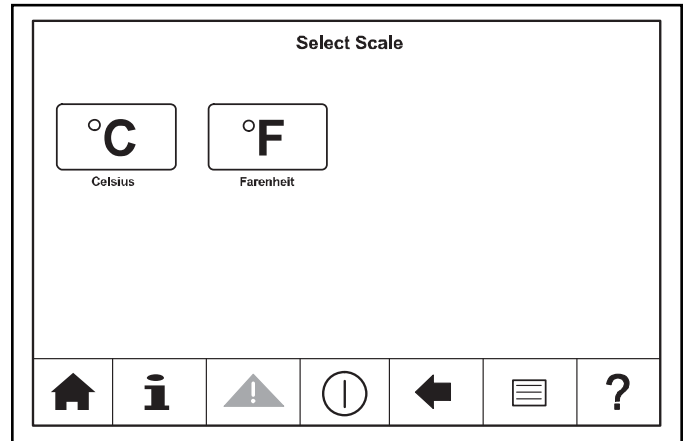





Figure-48

## About Key

The about key  is used to display information about the grill, including the model, bill of material (BOM), store ID and IP, system date, and system time. Use the arrow keys to scroll forward or backward through the grill component information screens. Press the checkmark key  or X key  to return to the Select Function screen. See Figure 49.

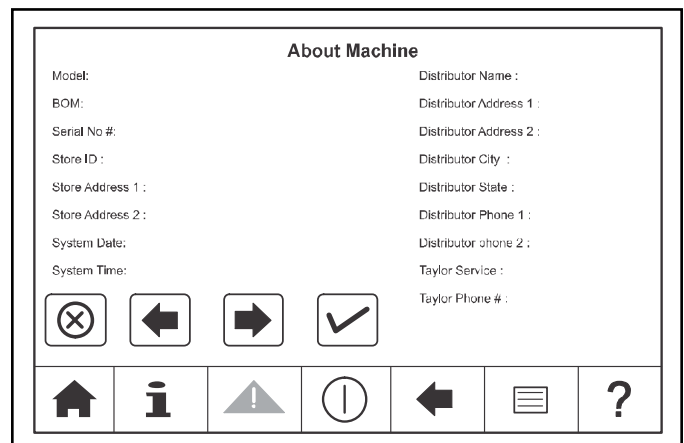





Figure-49

## Volume Key

The volume key  is used to display the current volume setting. To change the setting, use the up and down arrow keys. Press the checkmark key  to confirm the selection or press the X key  to return to the Select Function screen without saving the selection. See Figure 50.

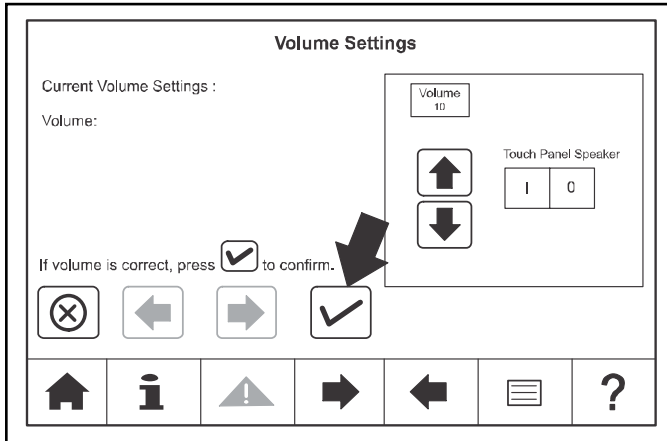





Figure-50

## Brightness Key

The brightness key  is used to display the current brightness setting. To change the setting, first select the display Key . Use the up and down arrow keys to adjust the brightness. Press the checkmark key  to confirm the selection or press the X key  to return to the Select Function screen without saving the selection. See Figure 51.

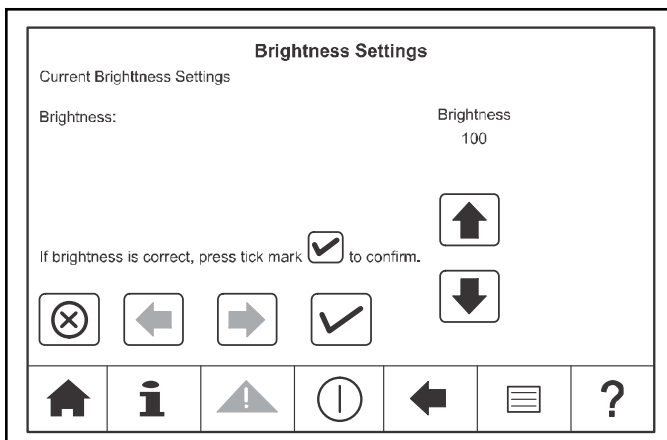



Figure-51

## Language Key

The language key  is used to list the available languages. Select the current language setting and press the back arrow key to return to the Select Function screen. See Figure 52.

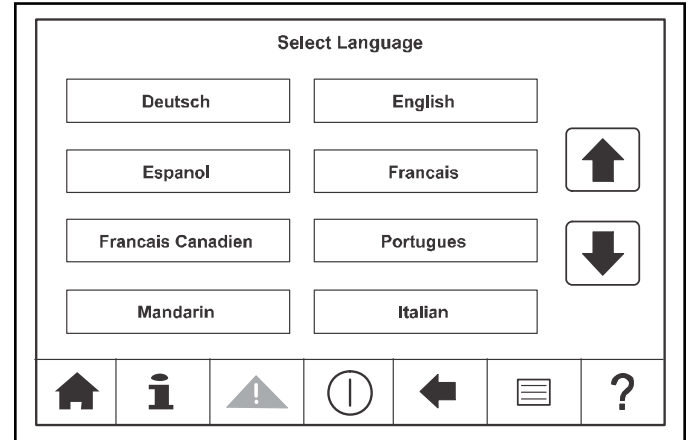



Figure-52

## Font Limits Key

The font limits key  allows you to change the size of the screen font. See Figure 53.

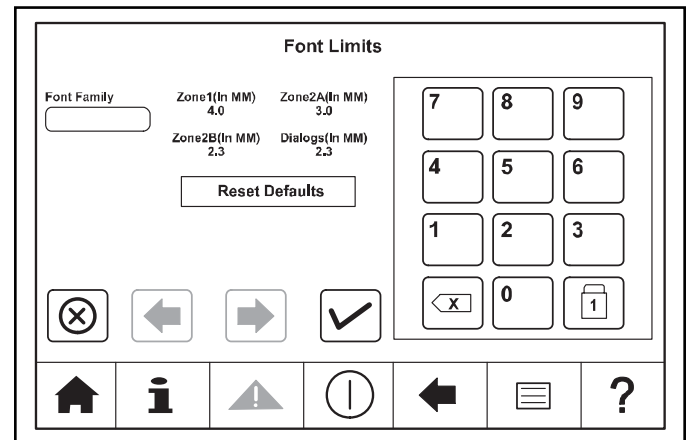



Figure-53

## Seconds Only Key

The seconds only key  allows you to change the countdown timer from seconds only to minutes only. See Figure 54.

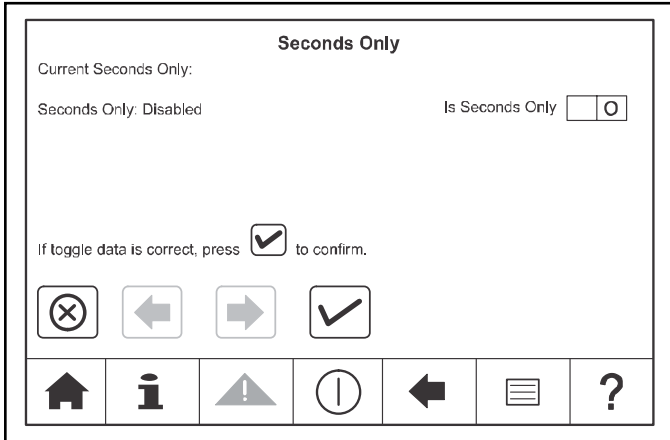

Figure-54

## Copy To / Copy From Keys

After inserting a USB drive, select the Copy To key. Pressing this key will generate a CSV file, which can be opened in Microsoft Excel. See Figure 55.

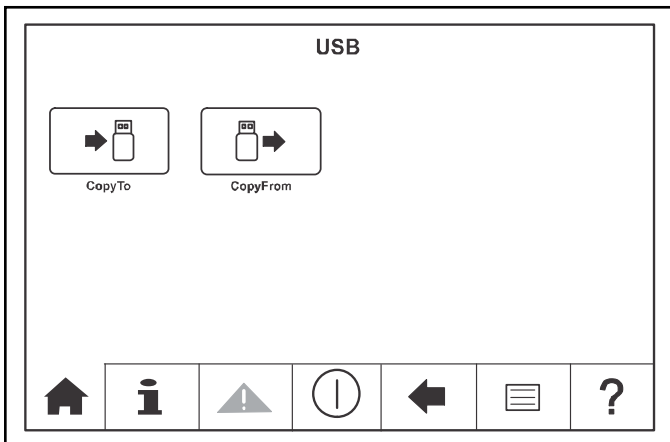

Figure-55

The following screen will display as the files are downloading to the USB drive. See Figure 56.

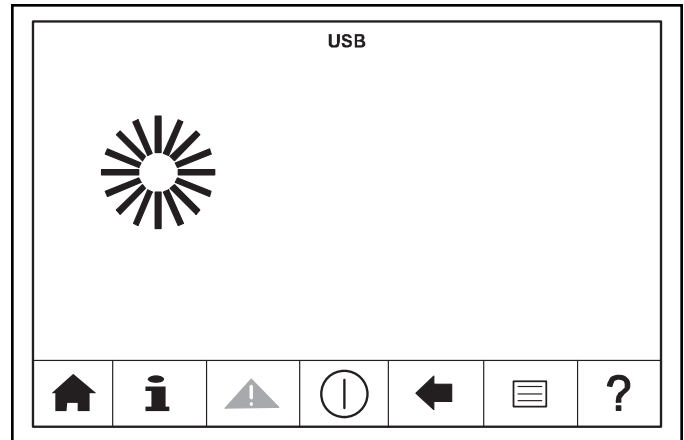



Figure-56

## Firmware Manager Key

The firmware manager key  is used to display the CONFIGURATION screen. Press the CLOSE key to return to the Select Function screen. See Figure 57.

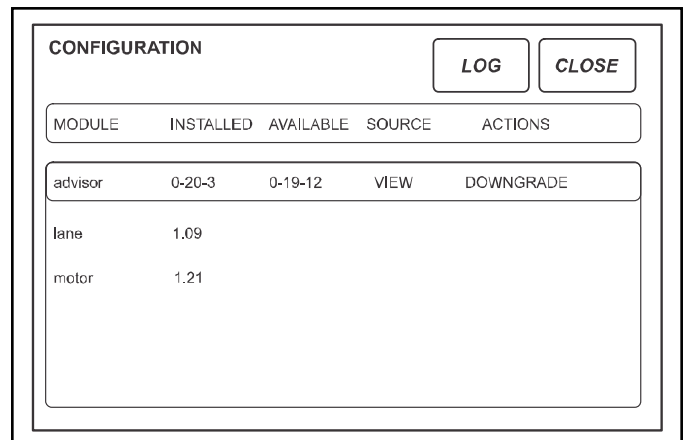

Figure-57

## Grill Mode Key

Press the Grill Mode key **M**. Select manual or auto. See Figure 58.

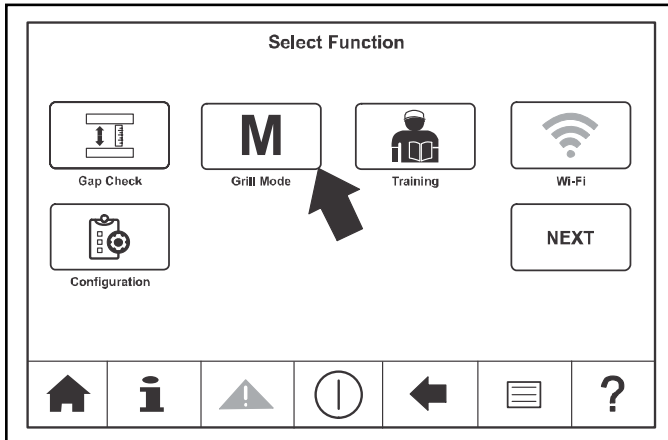

Figure-58

Press the back arrow key  to return to the Select Function screen.

If auto is selected, the only functional key in the cooking settings screen is Grill Mode **M** key.

If the auto key is selected, press the Grill Mode **M** key.

Press the checkmark key  to confirm the selection.

If manual is selected, press the appropriate recipe item to be cooked. Initiate the cook cycle by pressing either the start key on the control screen or by pressing the STANDBY button.

## Cooking Product

Press the home  key.

Select the desired product. See Figure 59. What appears is dependent upon grill mode.

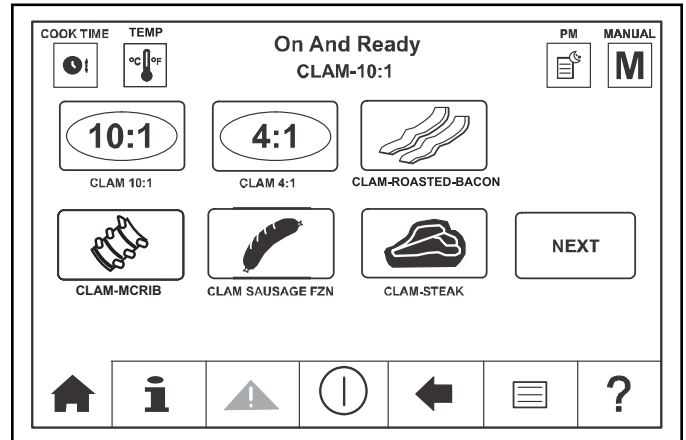

Figure-59

Select the STANDBY button. See Figure 60.

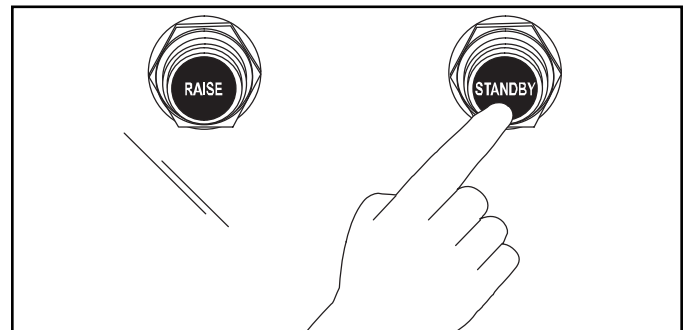





Figure-60

The platen will lower, and the product will begin to cook. The countdown timer will then appear.



**WARNING!** The upper platen surface is very **HOT**. Use extreme caution when wiping the release material sheet. Failure to comply can result in severe personal injury.

## Recipe Management

1. Select the menu  key.
2. Select the settings  key.
3. Enter the manager passcode 1955.
4. Select the checkmark  key.
5. Choose the Recipe Management key . See Figure 61.

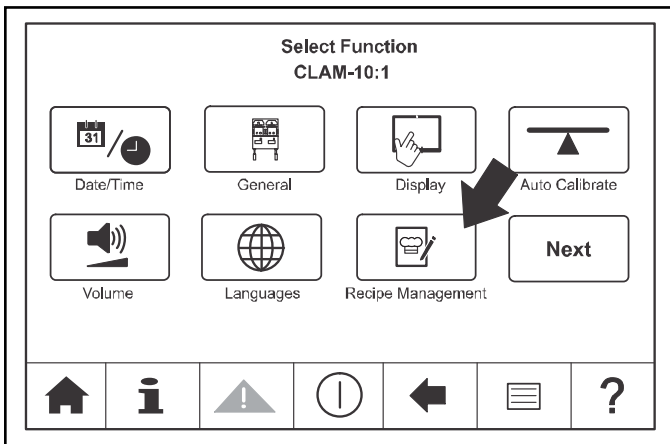

Figure-61

6. Select the Editing key. See Figure 62.

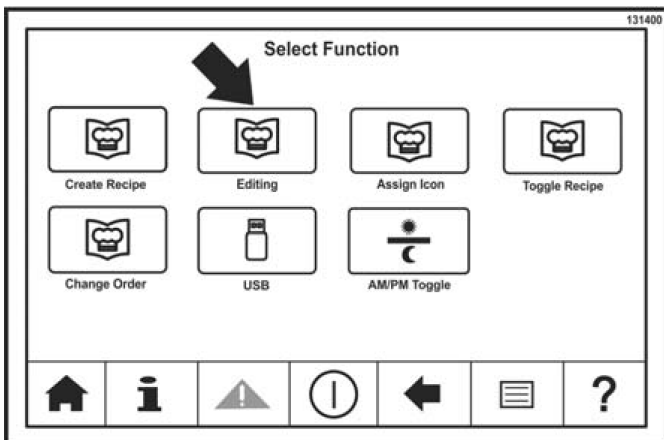

Figure-62

7. If the recipe name is correct, press the next button.

8. If the name is not correct, press the menu item to select the recipe you want to edit. See Figure 63 and Figure 64.

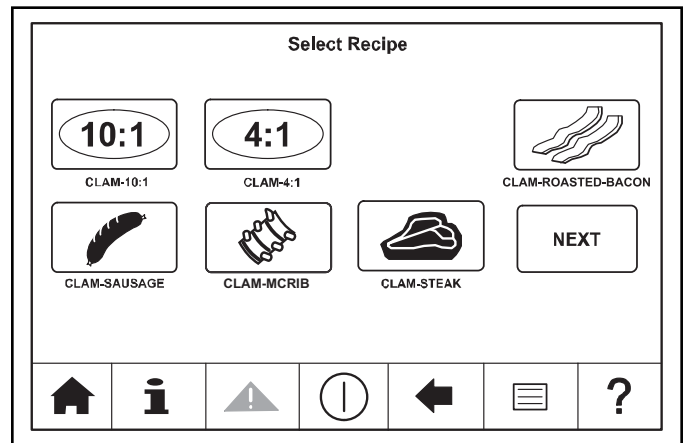

Figure-63

9. Touch the board to activate the keyboard if the recipe is not correct.

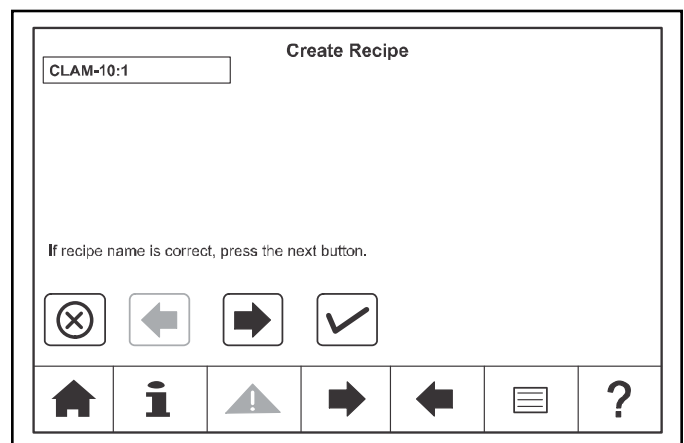

Figure-64

10. Type the name of your new recipe. (The back arrow key is used as a backspace key.) Select DONE when complete. See Figure 65. Then select the back arrow key. See Figure 64.

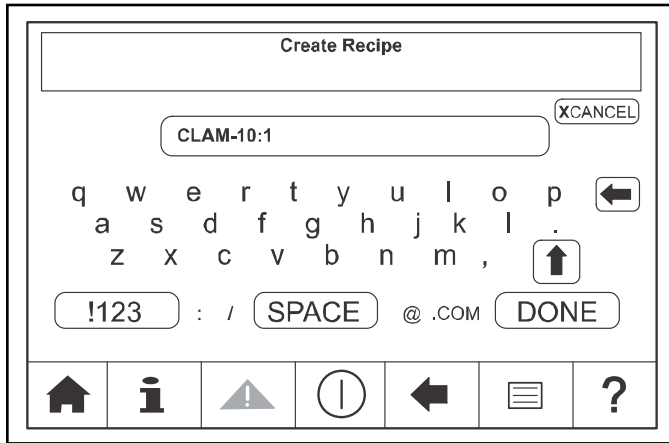

Figure-65

- **AM/PM, ALLDAY, Not AM/Not PM (disabled)**– Current loaded product time mode of operation.
- **Remove Alarm**–Current loaded product cook removal alarm. Configuration options are auto and manual.
- **Auto Selection**–When in this mode, the grill will detect a range of products which are set up in the recipes configuration. These recipes can not overlap in min and max thickness ranges. If they do, then a separate screen is shown showing this conflict. You can select the product that you want to cook in that instance.
- **Flat Bread Prep**–Current loaded product prepare bun in time.
- **Clam or Flat**–Allows the user to select the mode of the grill for cooking.
- **Stages**–This is the number of cook stages. See Figure 66.

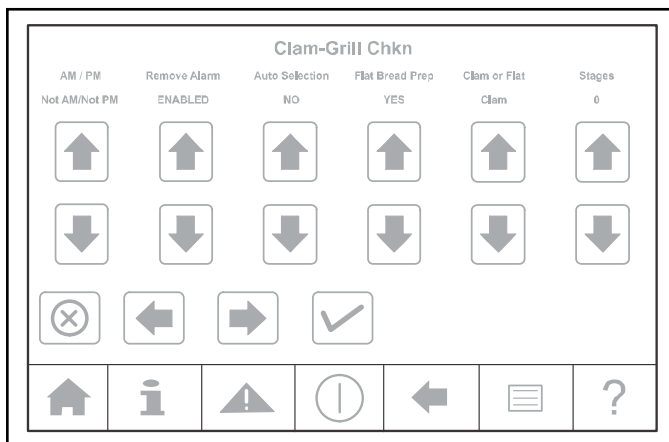

Figure-66

- **Flat Functions**–A non clam item.
- **Bread Prep Alarm**–Current loaded product prepare bread in time alarm (auto/manual).
- **Function 1, 2, 3 and Measured Time**–(Flat Items Only)
- **Turn In**–Indicates the currently loaded product's amount of remove in time that is dedicated to cooking before a turn is executed.
- **Turn Alarm**–Currently loaded product turn in time alarm. Configurations are auto or manual.
- **Sear In**–Indicates the currently loaded product amount of remove in time that is dedicated to cooking before a sear is executed. See Figure 67.
- **Function 1,2 and 3 Alarm**–(Flat Items Only)
- **Turn Alarm**–Current loaded product turn in time alarm. Configurations are auto or manual.
- **Sear Alarm**–Current loaded product sear in time alarm. Configurations are auto or manual.

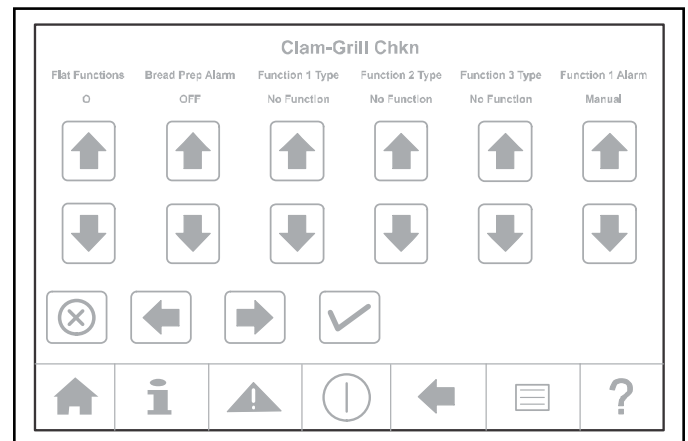

Figure-67

- **Turn/Sear Alarm**—Current loaded product turn/sear in time alarm. Configurations are auto or manual.
- **Regap Feature**—Current loaded product final stage gap before removal.
- **Enable Tilt**—Tilt the lower plate to pour grease into trays at end of cook cycle.
- **Clam Flip**—Allow for a double cook of platen open and close feature.
- **Timeout Seconds**—Adjust five-second timeout period at end of cook cycle. See Figure 68.



Figure-68

11. The egg ring is used for chicken and eggs. The egg ring gap is the thickness of the ring. See Figure 69.

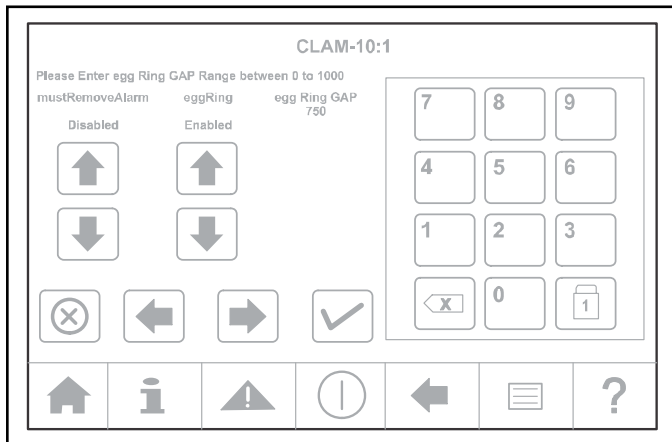

Figure-69

- **Must Remove In**—The time in which the product should be removed for the grill. There is an associated alarm with this.
- **Remove In**—Total cook time in seconds.
- **Remove Gap**—(Clam items only) Current loaded product final stage gap before removal.
- **Stage 1 Time**—(Stage 1 seconds, clam items only) Indicates the currently loaded product's amount of remove in time that is dedicated to stage 1 timing.
- **Stage 1 Gap**—Indicates gap distance for stage 1.
- **Stage 2 Time**—(Stage 2 seconds, clam items only) Indicates the currently loaded product's amount of remove in time that is dedicated to stage 2 timing.
- **Stage 2 Gap**—Indicates gap distance for stage 2.
- **Stage 3 Time**—(Stage 3 seconds, clam items only) Indicates the currently loaded products amount of remove in time that is dedicated to stage 3 timing.
- **Stage 3 Gap**—Indicates gap distance for stage 3. See Figure 70.

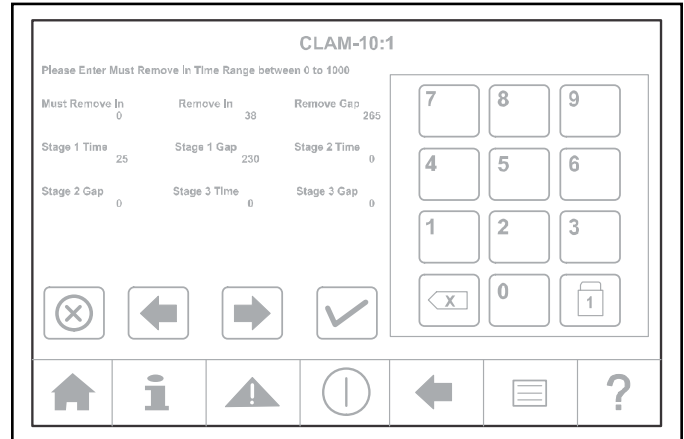

Figure-70

- **Icon ID**–The number of the icon in the list in the controller. It is used to link the icon to the recipe. See Figure 71.

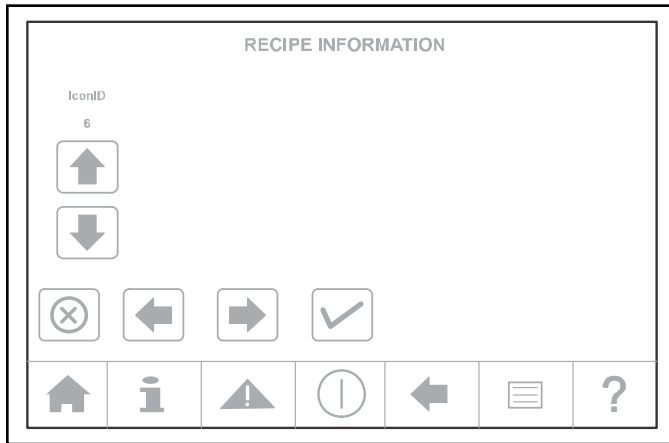

Figure-71

- **Must Remove In**–The time in which the product should be removed for the grill. There is an associated alarm with this.
- **Remove In**–Total cook time in seconds.
- **Remove Gap**–Current loaded product final stage gap before removal.
- **Stage 1 Time**–Indicates the currently loaded product's amount of remove in time that is dedicated to stage 1 timing.
- **Stage 1 Gap**–Indicates gap distance for stage 1.
- **Stage 2 Time**–Indicates the currently loaded product's amount of remove in time that is dedicated to stage 2 timing.
- **Stage 2 Gap**–Indicates gap distance for stage 2.
- **Stage 3 Time**–Indicates the currently loaded products amount of remove in time that is dedicated to stage 3 timing.
- **Stage 3 Gap**–Indicates gap distance for stage 3. See Figure 72.

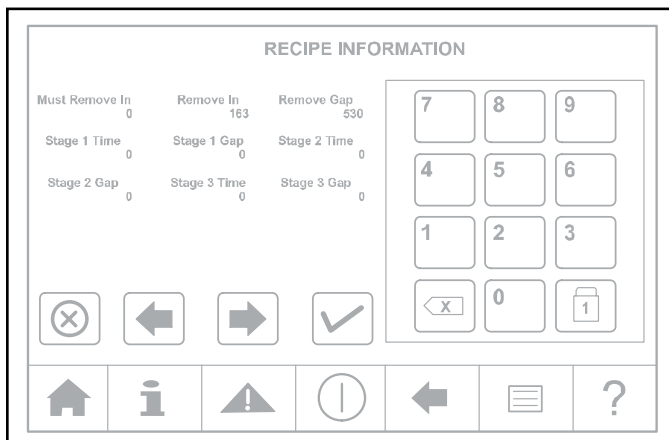

Figure-72

- **Top Platen Temp**–Current loaded product platen cooking temperature setpoint.
- **Bottom Platen Temp**–Current loaded product platen cooking temperature setpoint.
- **Bread Prep Time**–Currently loaded product prepare bun in time.
- **Auto Min. Detect**–Indicates the currently loaded product minimum auto selection gap setting.
- **Auto Max. Detect**–Indicates the currently loaded product maximum auto selection gap.
- **Function 1, 2, 3, and Measured Time**–(Flat items only)
- **Turn In**–Indicates the currently loaded product's amount of remove in time that is dedicated to cooking before a turn is executed.
- **Turn Alarm**–Currently loaded product turn in time alarm. Configurations are auto or manual.
- **Sear In**–Indicates the currently loaded product amount of remove in time that is dedicated to cooking before a sear is executed. See Figure 73.

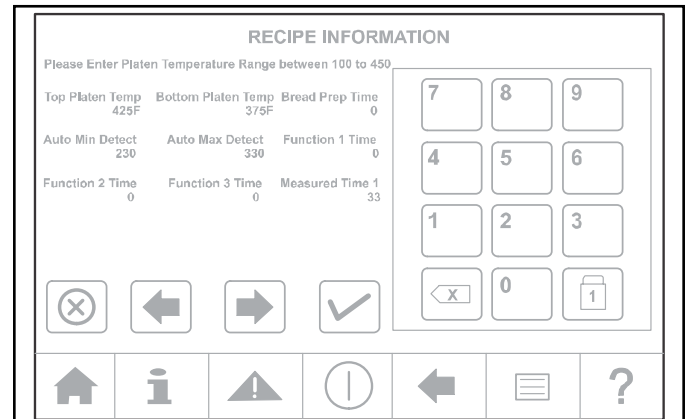

Figure-73

12. Select the checkmark  key to save and exit the screen. See Figure 77.

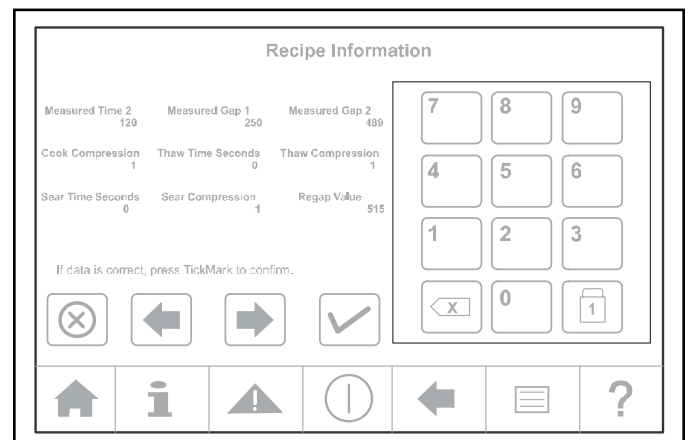

Figure-74

13. Select the Create Recipe key to create a new recipe.  
See Figure 75.

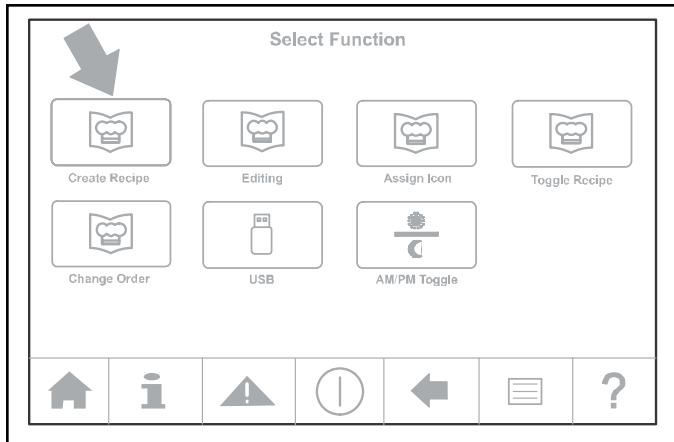

Figure-75

14. Select the recipe. See Figure 76.

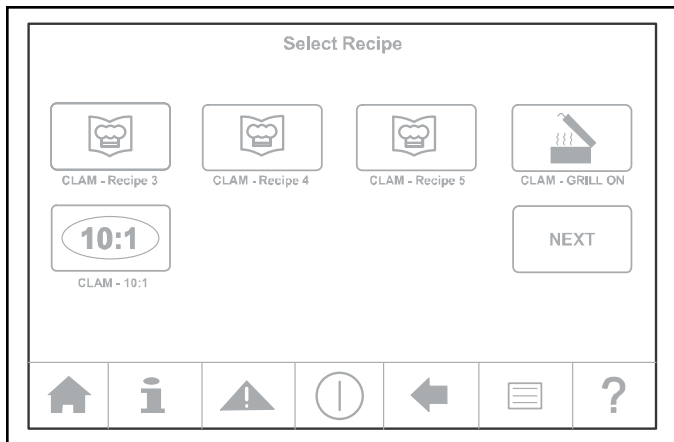



Figure-76

15. If the recipe name is correct, press the checkmark key  to confirm. If the name is not correct, press the menu item under Create Recipe. See Figure 77.

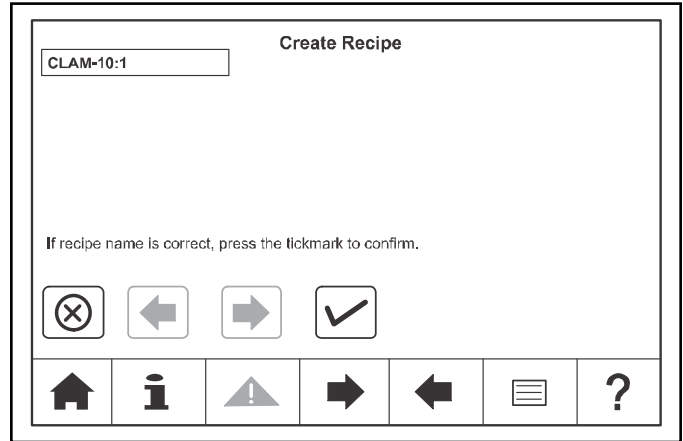

Figure-77

16. Type the name of your new recipe. (The back arrow key is used as a backspace key.) Select DONE when complete. See Figure 78.

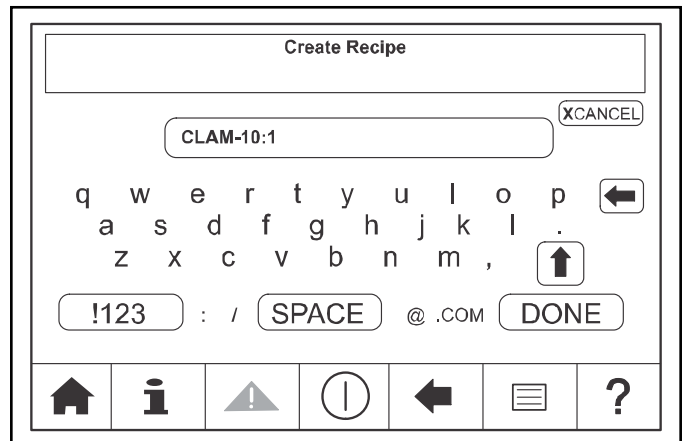

Figure-78

## Probe Calibration

Thermocouple probes are located on the front and rear of the lower grill plates and upper platen. The measurements should be taken from front to back and left to right on all model grills.

Figure 79 identifies the probe locations for the Model C850, C852, and C858 grill.

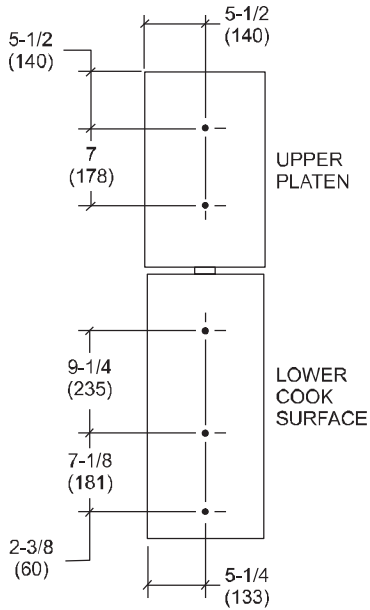

Figure-79

Figure 80 identifies the probe locations for the Model C854, C856, and C860 grill.

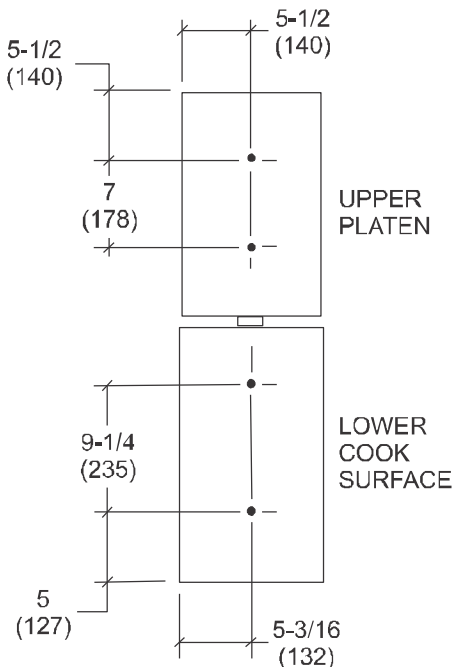





Figure-80

## Surface Temperature Calibration

**Important!** Make sure the grill has been turned on and allowed to reach set point. (approx. 45 min.)

1. Remove all upper and (lower if used) Teflon from the cook surfaces.
2. Make sure all surfaces are clean of carbon.
3. Use the restaurants surface probe.
4. Select the Temperature  Key (top left 2nd key) on the main screen.
5. Press and hold for 3 seconds.
6. Place the surface probe on the desired zone to be calibrated. Refer to Probe Calibration on page 49.
7. Using the up/down arrow keys, adjust the temperatures to match the surface probe temperatures.
8. Press the checkmark  Key to save the adjustments.

## Adjust Cook Times

1. Select the menu item to have the cook time adjusted. Select the menu item key it will be highlighted in blue.
2. Select the cook time  Key located on the top left of the main screen.
3. Press and hold for 3 seconds.
4. Using the up/down arrow key adjust the cook time needed.
5. Press the checkmark  Key to save the adjustments.

## Patty Placement

Placement procedures of meat products must be followed on the grill. Meat must be placed on the lower grill platen, two patties at a time, from front to back, per the patty placement guide on page 51. When the cook cycle is complete, the upper platen will raise.

The patties must be removed immediately after the upper platen has been raised to the OPEN position and the meat has been seasoned. Remove the patties, one at a time, from front to back and right to left, per the patty placement guide on page 51.

The maximum amount of meat patties to be cooked on each heat zone is as follows:

- 8 regular (10:1) patties
- 6 (6:1) patties
- 4 quarter pound (4:1) patties
- 8 sausage patties
- 6 circular bacon

The U.S. Recipe list includes:

- CLAM 10:1
- CLAM 6:1
- CLAM 4:1
- CLAM-GRILL CHKN
- CLAM-FRESH 4:1
- CLAM-SAUSAGE FZN
- CLAM-MCRIB
- CLAM-STEAK
- FLAT-GRILL CHKN
- FLAT-FOLDED EGG
- FLAT-ROUND EGG
- FLAT-10:1
- FLAT-4:1
- FLAT-MCRIB
- FLAT-SAUSAGE FZ
- FLAT-HOT CAKES
- CLAM-MUSHROOMS
- CLAM-ROAST BACON
- CLAM-FOLDED EGGS
- CLAM-ROUND EGGS
- CLAM-LOR ONION
- LIFECYCLE

The following chart is to be used as the patty placement guide.

# SAUSAGE, CIRCULAR BACON AND PATTY PLACEMENT GUIDE

Models C850, C852, C854, C856, C858, C860 Next Generation Grill 10:1, 6:1, 4:1

## Laying Pattern

**Note:** Lay the patties on the grill two at a time from front to back.

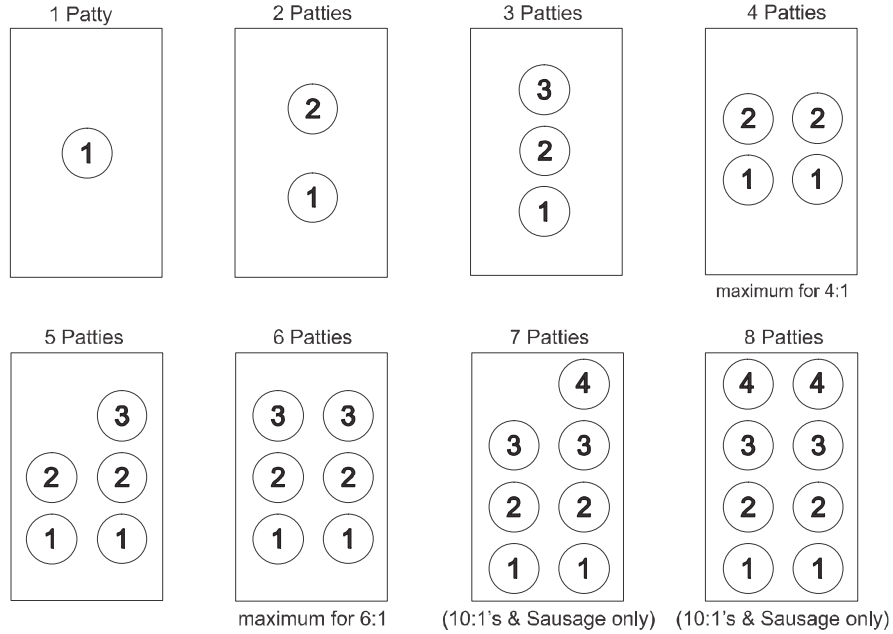
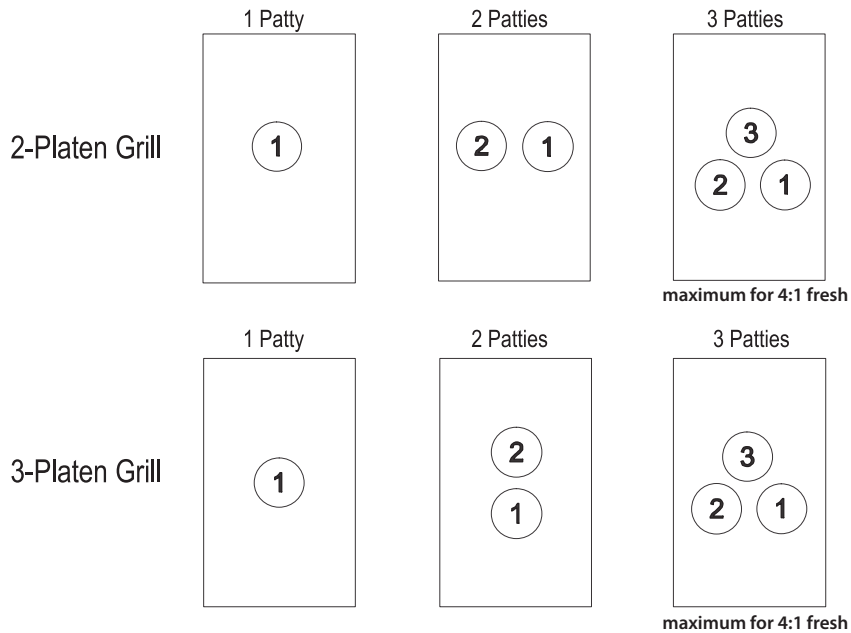

Figure-81

## Fresh Product Patty Placement Guide



30170\_A

Figure-82

## Pulling Pattern

**Note:** Remove the patties one at a time in the order shown from front to back and right to left.

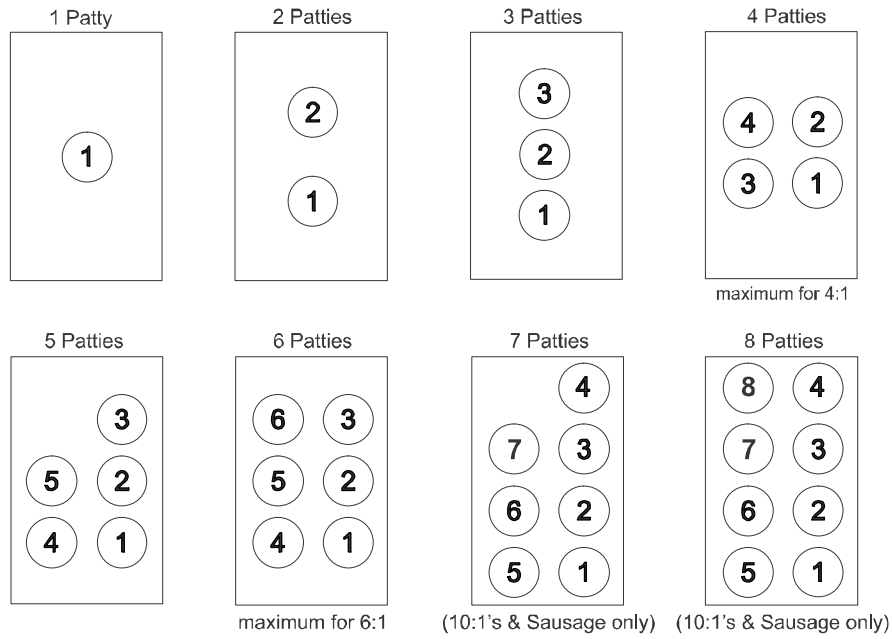

Figure-83

**Note:** Patty placement procedures for international markets may differ. Follow the recommendations of your local McDonald's authorities.

## STANDBY PROCEDURES

Whenever the grill is idle and product is not being cooked, the upper platen must be placed in the STANDBY position.

1. To place the upper platen in the STANDBY position, press the STANDBY button twice from the open position. See Figure 84.

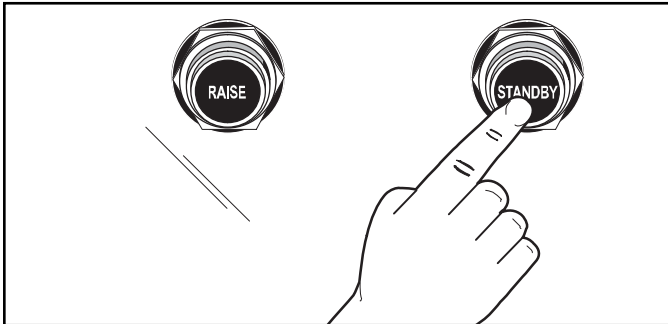

Figure-84

2. To raise the upper platen to the OPEN position to resume cooking, press the RAISE button. See Figure 85.

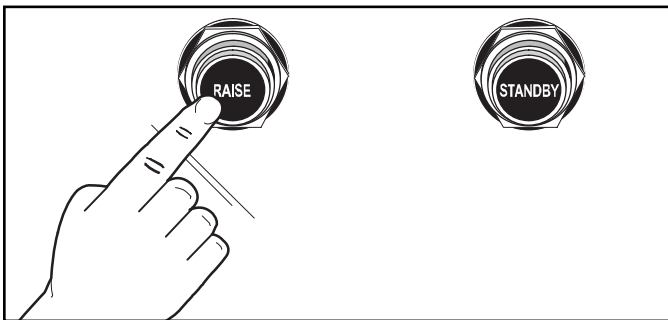

Figure-85

**Note:** If the grill remains idle for five continuous minutes without being placed in STANDBY, a tone will sound and the display will flash PUT GRILL IN STANDBY.

**Note:** FRANCE ONLY: With the upper platen in the OPEN position, press the STANDBY button to enter the Standby. To start cooking, lower the upper platen.



**CAUTION!** Never use force to raise the upper platen. Damage to components may result. Only use the RAISE button to open the upper platen.

## CLEANING AFTER EACH RUN OF PRODUCT (USING LOWER RELEASE SHEETS)

**Note:** This manual contains separate procedures for grills that use lower release sheets and for grills that do not use lower release sheets. Use the appropriate procedures for your grill.

**If your grill does not use lower release sheets, go to page 54.**

**Note:** Do not use excessive pressure when wiping the release sheet with the squeegee. Using excessive pressure can scratch or tear the release sheet.

1. Squeegee the lower release sheet from front to back. See Figure 86.

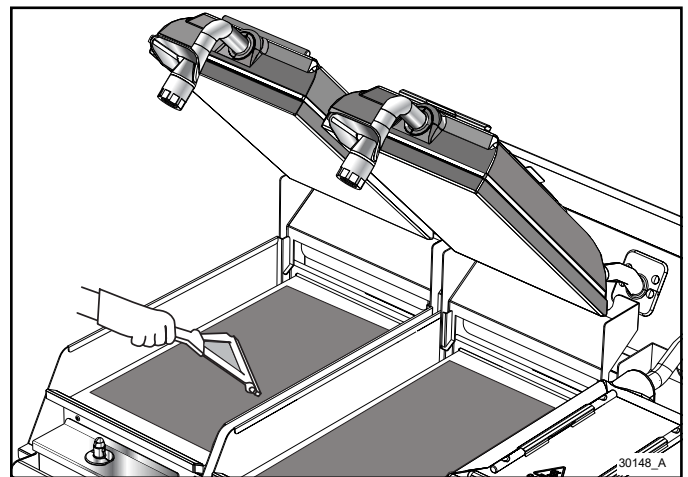

Figure-86

2. Squeegee the upper release sheet from top to bottom. See Figure 87.

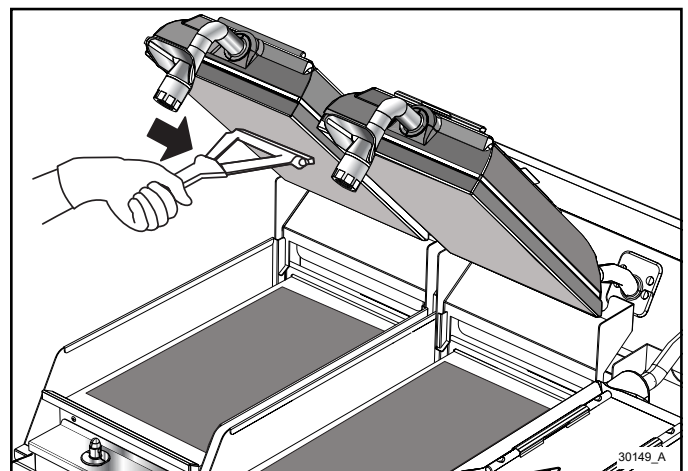

Figure-87

3. Push the residue into the grease trough.

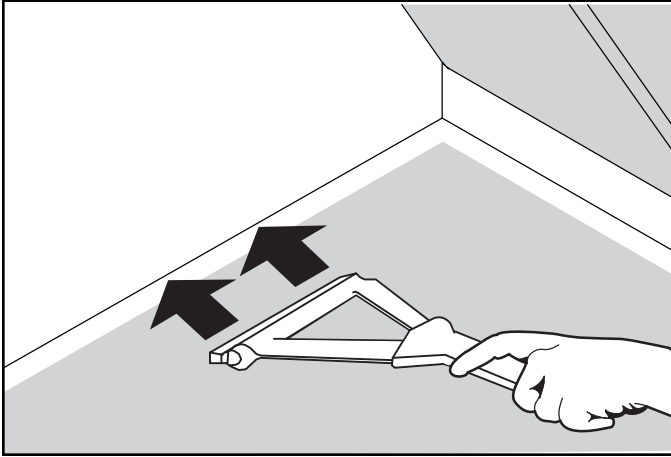

Figure-88

4. Carefully squeegee the air bubbles from the center to the side, making sure the release sheet does not become folded or creased.

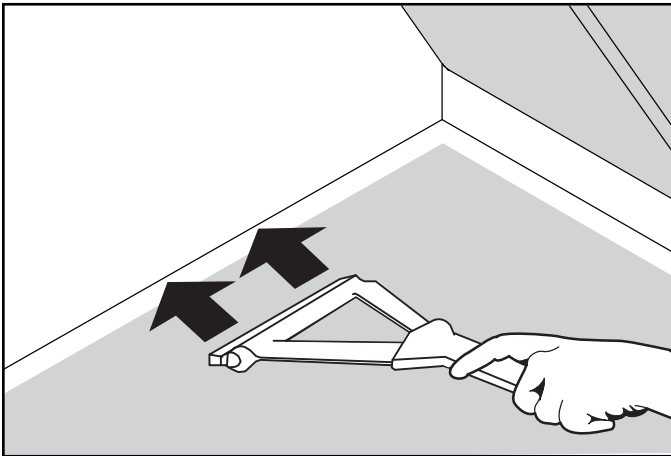

Figure-89

5. Wipe the squeegee with a sanitizer-soaked grill cloth.

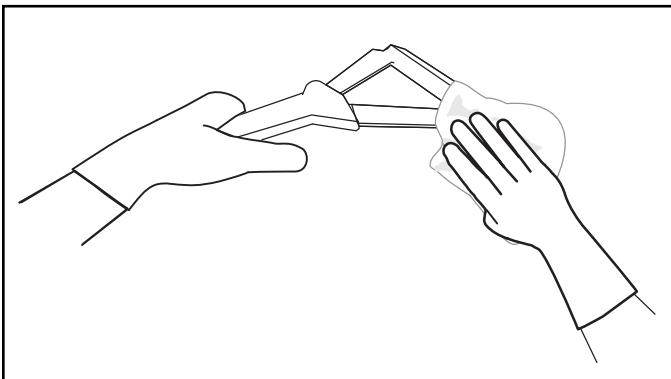

Figure-90

6. Wipe the top platens and grill surface four times an hour with a sanitizer-soaked grill cloth.

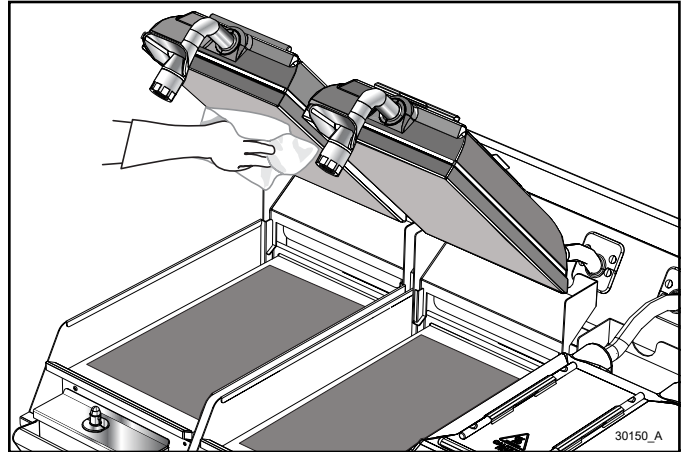

Figure-91

7. As needed during operation, use a sanitizer-soaked grill cloth to clean the rear grease shield and the bullnose areas. See Figure 92.

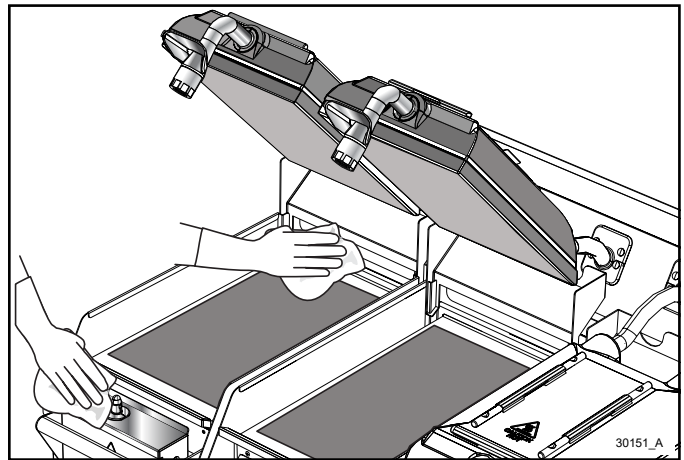

Figure-92



**CAUTION!** The upper platen surface and release sheet are very hot. To prevent burn injuries, wear heat-resistant gloves when replacing the release sheets.

**CLEANING AFTER EACH RUN OF PRODUCT  
(NOT USING LOWER RELEASE SHEETS)**

**Note:** This manual contains separate procedures for grills that use lower release sheets and for grills that do not use lower release sheets. Use the appropriate procedures for your grill.

**If your grill uses lower release sheets, go to page 53.**

- Using the grill scraper, scrape the grease on the lower grill plate from front to back. **Do not** scrape across the rear of the lower grill plate with the grill scraper. See Figure 93.

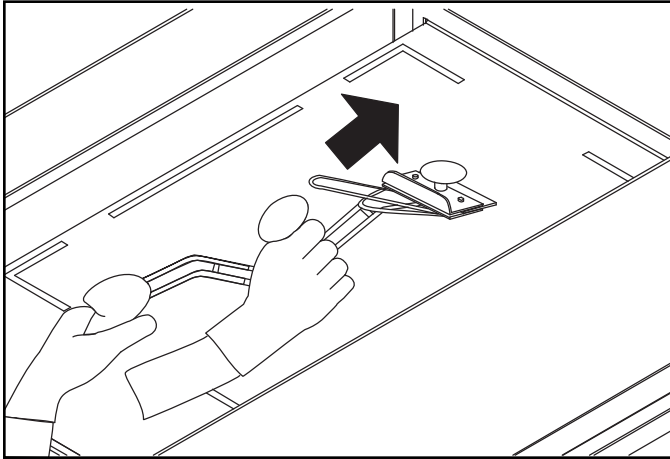

Figure-93

- Use the wiper squeegee to clean the release sheet on the upper platen. Use a diagonal motion to clean the sheet. Hold the handle at a slightly upward angle, with the wiper end facing downward. See Figure 94.

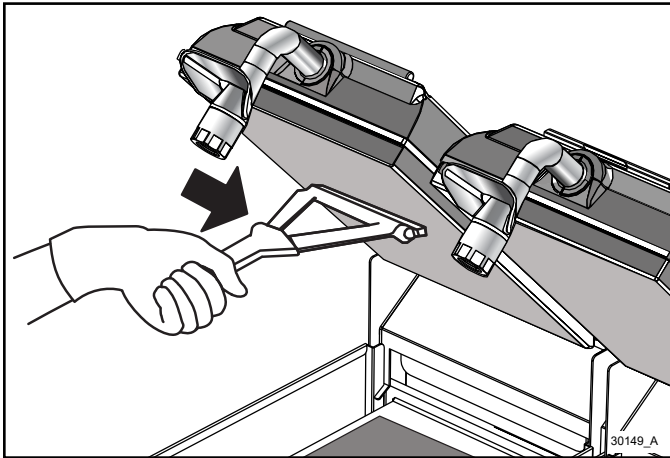

Figure-94

**Note:** Do not use excessive pressure when wiping the release sheet with the squeegee. Using excessive pressure can scratch or tear the release sheet.

- Using the wiper squeegee, push the grease at the rear of the lower grill plate into the grease can.

**Do not use the grill scraper for this step.** See Figure 95.

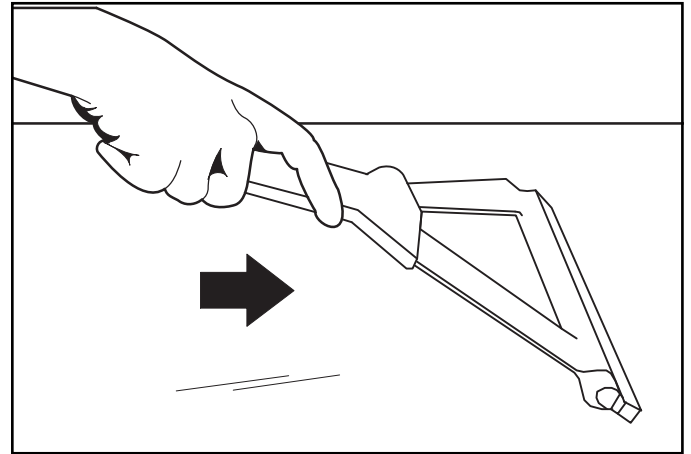

Figure-95



- Use the grill cloth to clean the rear grease shield and the bullnose areas as needed during operation.

**Note:** To increase the life of the release sheet, wipe it with a damp, folded grill cloth a minimum of **four times every hour**.

### To Display the Current Status

**Note:** The actual temperatures may be displayed at any time, including during a cook cycle.

Press the information key . The following information will be displayed.

- The current grill temperatures for the upper and lower plates
- The ambient temperature of the control board
- The clean key  displays the time since the grill was last cleaned and the length of time it took to clean the grill.
- The auto calibrate key  indicates if the grill is calibrated and the current menu item.

## Wipe Down Mode

1. Press the Wipe Down key to enter the Wipe Down mode. See Figure 96.

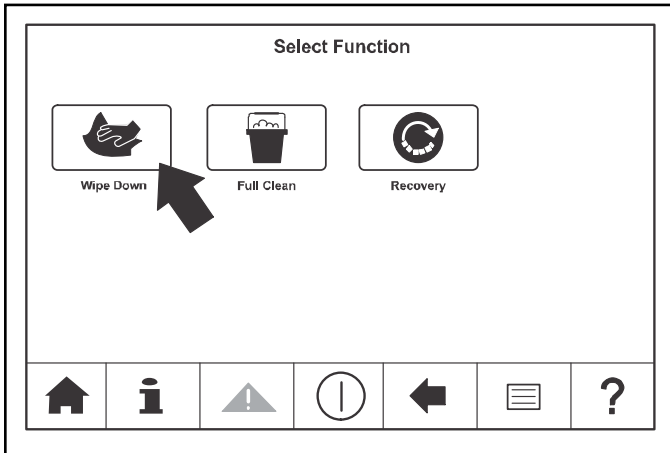

Figure-96

2. The following screen will allow you to move the platen up and down. See Figure 97.

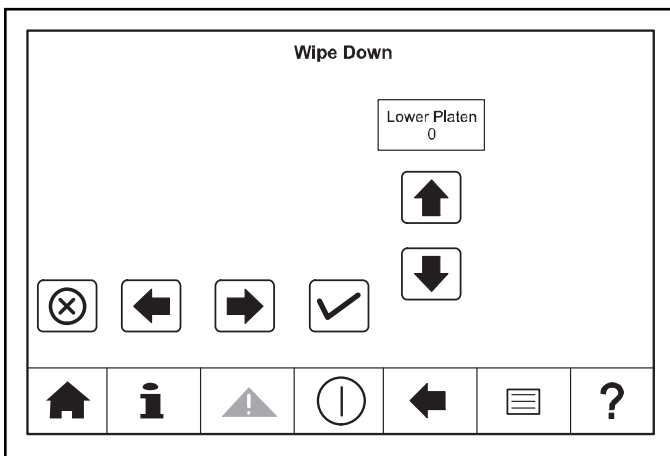



Figure-97

3. Press The Full Clean key . See Figure 98.

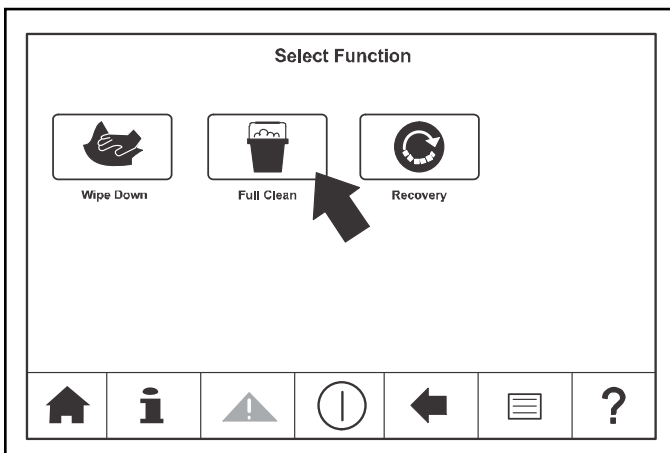

Figure-98

4. Remove the upper and lower release sheets from the grill. See Figure 99.

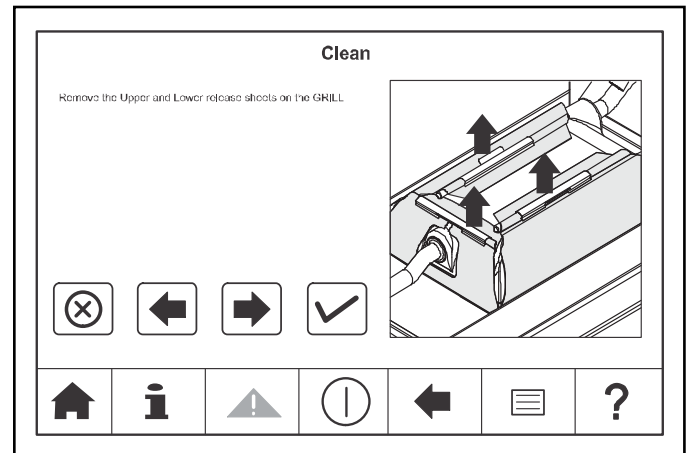

Figure-99

### DAILY CLEANING PROCEDURES (USING LOWER RELEASE SHEETS)

**Note:** This manual contains separate procedures for grills that use lower release sheets and for grills that do not use lower release sheets. Use the appropriate procedures for your grill.

**If your grill does not use lower release sheets, go to page 65.**



**CAUTION!** Never use cold water or ice to cool the upper platen or the lower grill plate. Failure to comply may result in equipment damage.

- Never use grill screens on the upper platen or the lower grill plate.
- Never allow the grill scraper or abrasive cleaning materials to come in contact with the release sheet.

1. Raise the upper platen to the OPEN position by pressing the red RAISE button. See Figure 100.

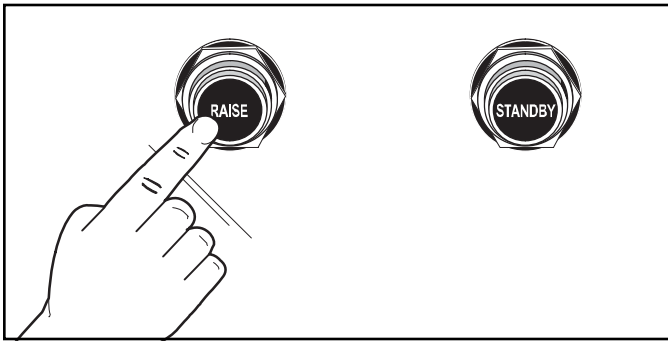





Figure-100



**CAUTION!** Never use force to raise the upper platen. Damage to components may result. Only use the RAISE button to open the upper platen.

2. Press the menu key  until the clean key  is displayed.
3. Press the clean key .
4. Press the full clean key .
5. Gather the necessary cleaning supplies while the grill is cooling down:
  - Kay® grill cleaning pad holder
  - Kay® grill cleaning pad
  - Kay® hi-temp tool w/flat paddle attachment
  - Flat paddle multi-use tool pad
  - Flat paddle universal pad
  - Kay® QSR heat-activated grill and toaster cleaner (HAGTC)
  - Heat resistant gloves (14 inches in length)
  - Kay® hi-temp tool with double-sided bristle brush
  - Squeegee
  - Sundae spoon
  - Release sheet storage tray
  - Soy adhesion flakes

When the cook surfaces reach the proper temperature for cleaning, “Cleaning in progress” will be displayed.

6. Press the Next  key to proceed.

7. Put on heat-resistant gloves. See Figure 101.

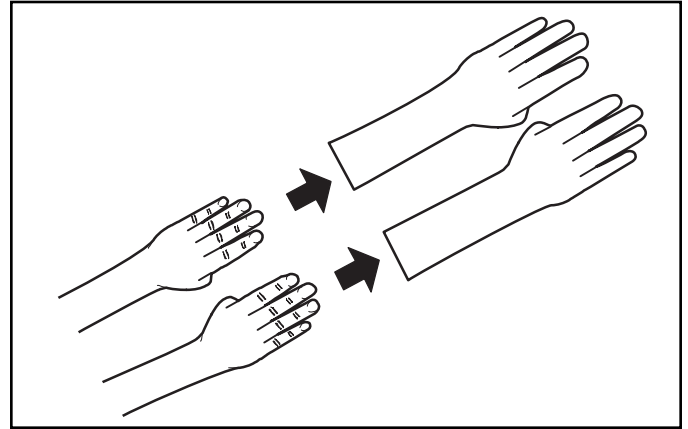

Figure-101

8. Use the sanitizer-soaked grill cloth to clean the exposed surfaces of the upper and lower release sheets. See Figure 102.

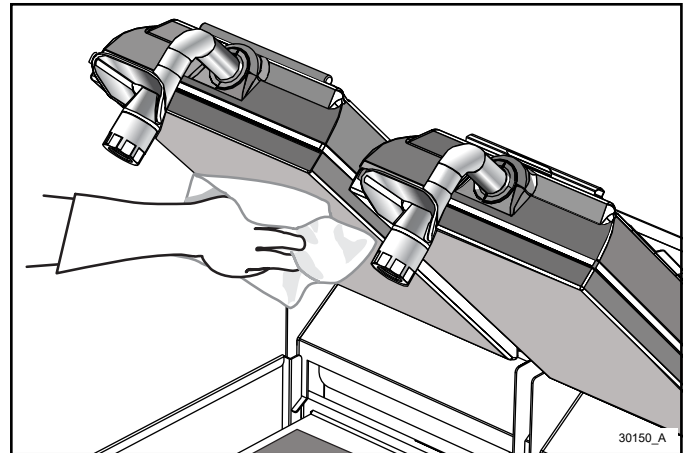

Figure-102

9. Spray a clean sanitizer-soaked grill cloth with one spray of grill cleaner. See Figure 103.

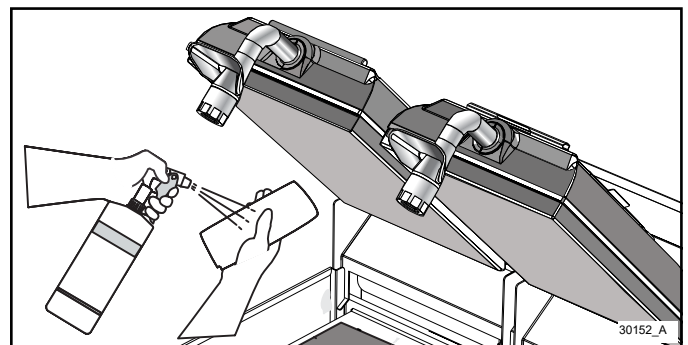

Figure-103

10. Use the sanitizer-soaked grill cloth to wipe clean the exposed surfaces of the upper release sheets, including the sides. Repeat the cleaning for the lower release sheets. See Figure 104.

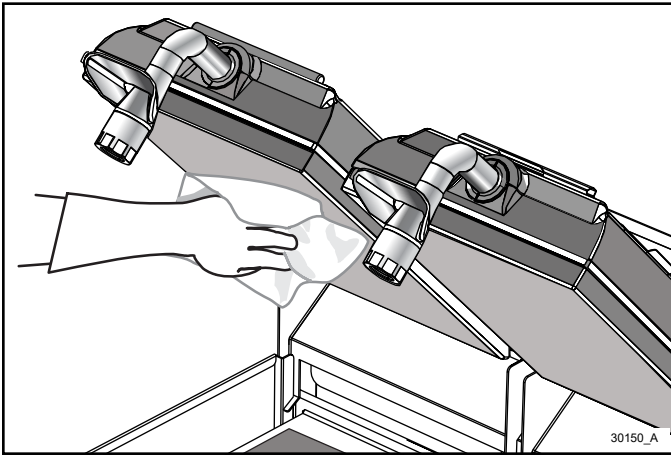

Figure-104

11. Rinse the upper and lower release sheets with a separate sanitizer-soaked grill cloth. Wipe until the grill cleaner residue has been fully removed. See Figure 105.

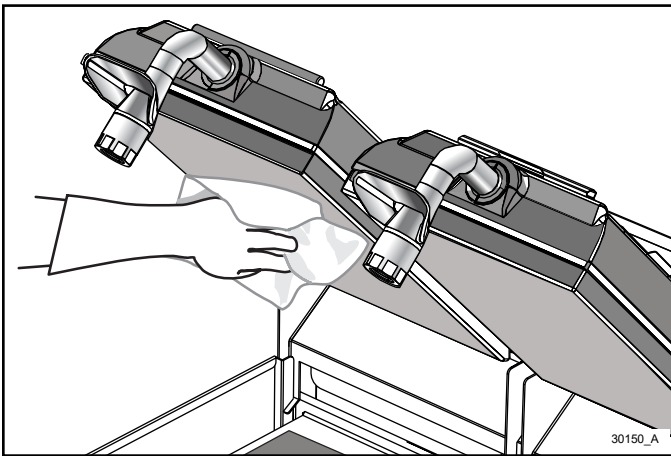

Figure-105

12. Remove the release sheet locking clips and the upper and lower release sheets. Wash and rinse the clips in the three-compartment sink. If necessary, soak them in a hot solution of SolidSense APSC to remove carbon accumulation. See Figure 106.

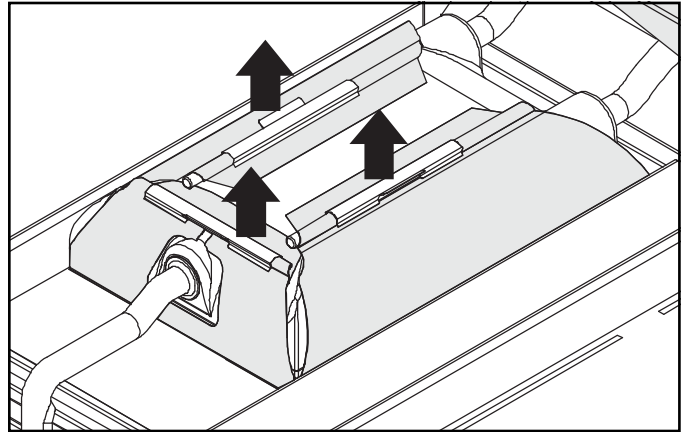

Figure-106

13. Place all release sheets flat on the release sheet storage tray, clean side down. Do not fold, crease, or place them on sharp objects. Do not clean the release sheets in the three-compartment sink. See Figure 107.

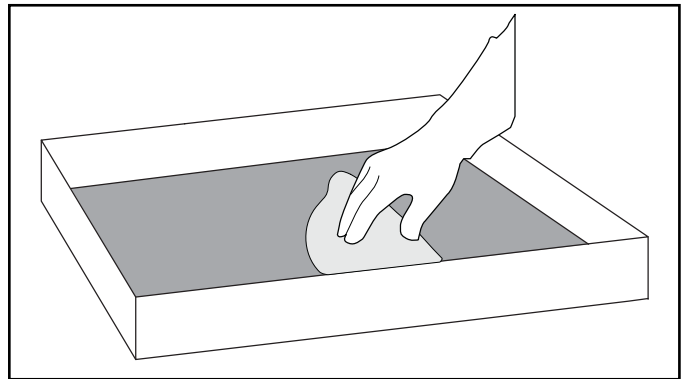

Figure-107

14. Spray a clean sanitizer-soaked grill cloth once with grill cleaner. Wipe the soiled side of the release sheet until clean. See Figure 108.

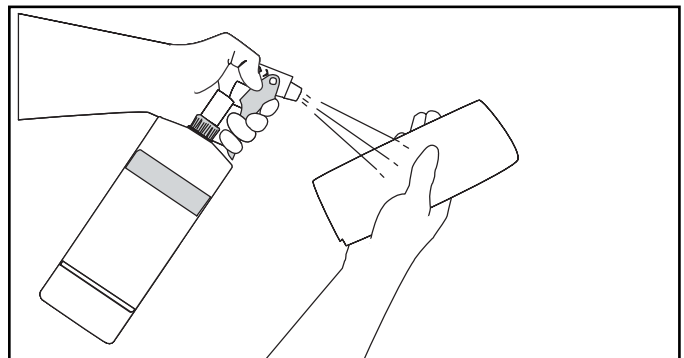

Figure-108

15. Rinse with a separate clean sanitizer-soaked grill cloth to rinse off the remaining grill cleaner. Repeat for all of the release sheets. See Figure 109.

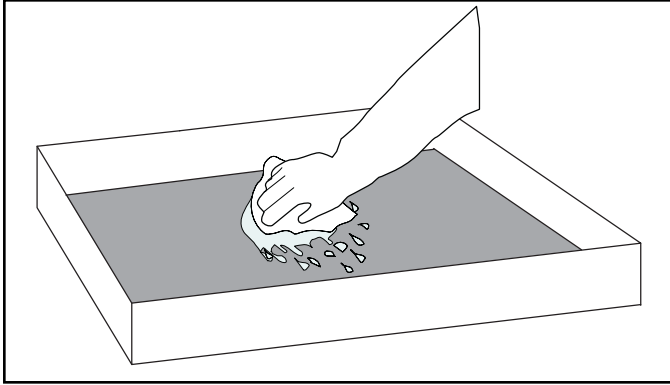

Figure-109

16. Spray the upper platens with grill cleaner, starting with the sides and back. If you have three upper platens, lower the middle platen first to easily access the adjoining sides of the right and left platens.
17. After spraying the sides, spray the surface of each upper platen three times to cover the bottom, middle, and top. See Figure 110.

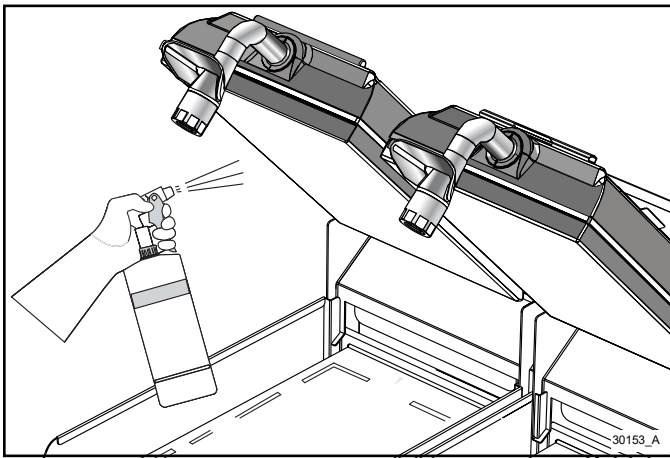

Figure-110

18. Firmly attach the cleaning pad to the Kay grill cleaning pad holder.

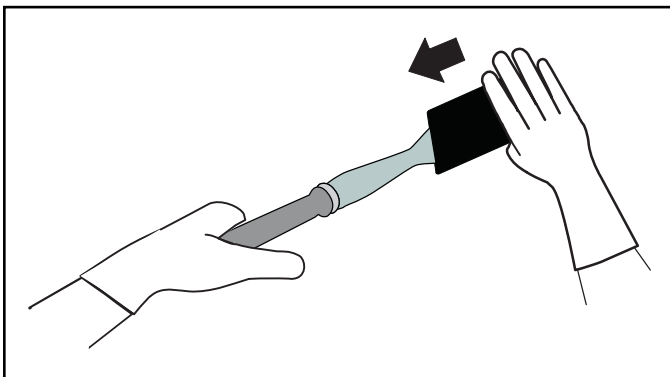

Figure-111

19. Using the Kay grill cleaning pad holder, distribute the grill cleaner around the upper platens to ensure full coverage. See Figure 112.

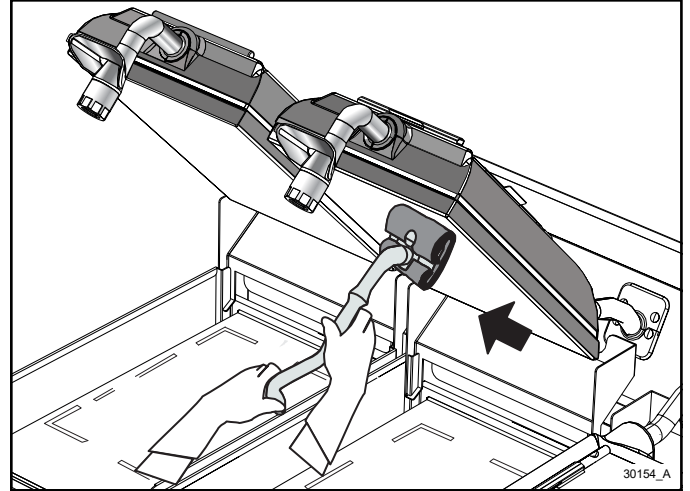

Figure-112

20. Remove the cap from the dosing bottle and squeeze the bottle to fill the dosing cup to ½ oz as marked. See Figure 113.

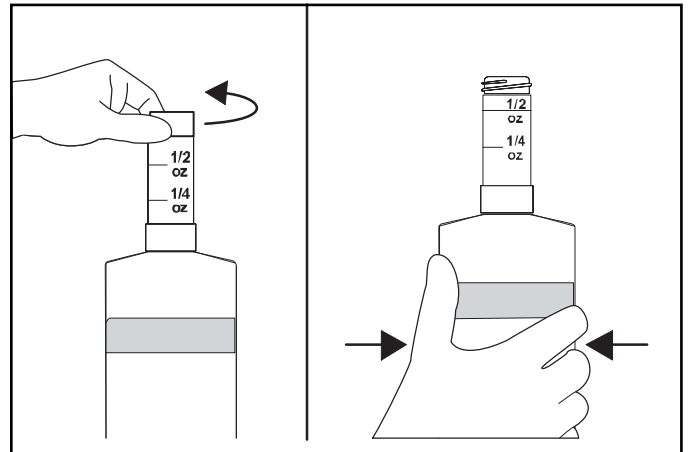

Figure-113

21. Beginning on the left lower plate, pour the dosed ½ oz. of grill cleaner from left to right in the shape of an arched M. Repeat for each lower plate until all of them are fully covered. See Figure 114.

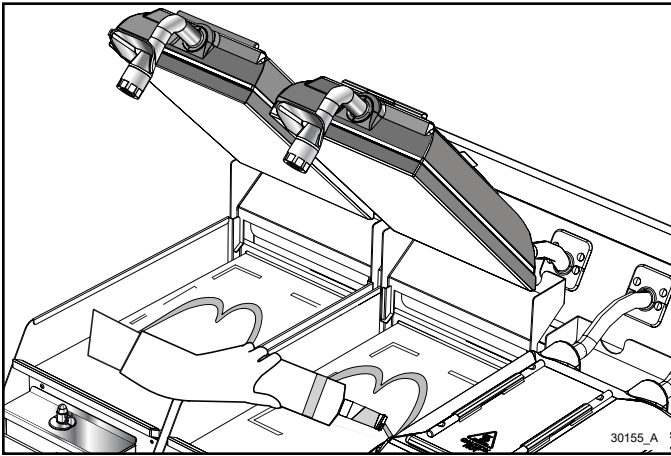

Figure-114

22. Spread the grill cleaner thoroughly on the lower surface to ensure full coverage. See Figure 115.

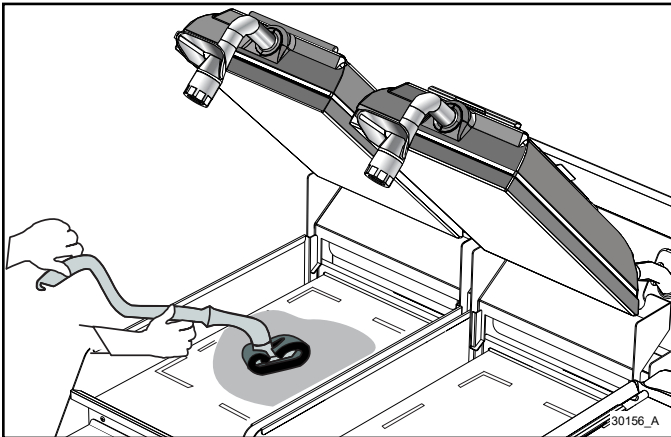

Figure-115

23. Scrub the upper and lower platen with the grill cleaning pad and holder. See Figure 116.

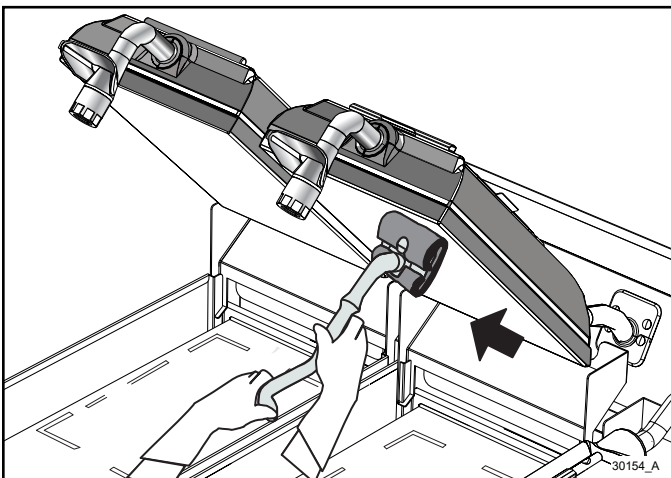

Figure-116

24. If needed, scrub the upper platen with the Kay double-sided grill brush. See Figure 117.

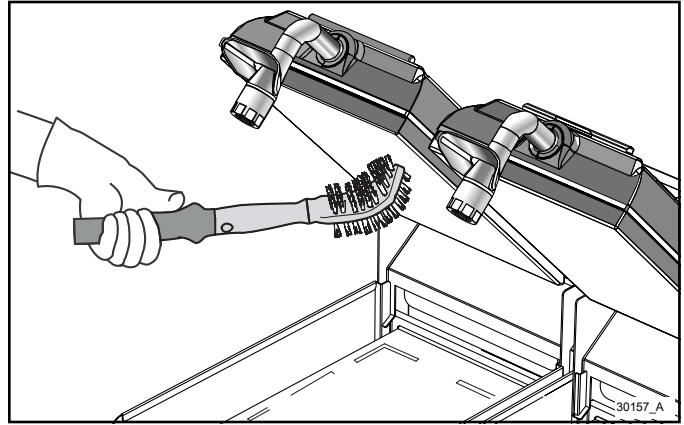

Figure-117

25. Using a sanitizer-soaked grill cloth, wipe the lower plate. See Figure 118.

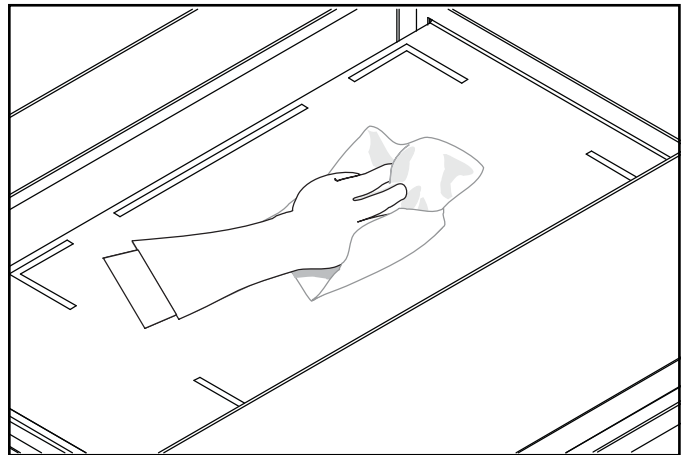

Figure-118

26. Pull out the grill. See Figure 119.

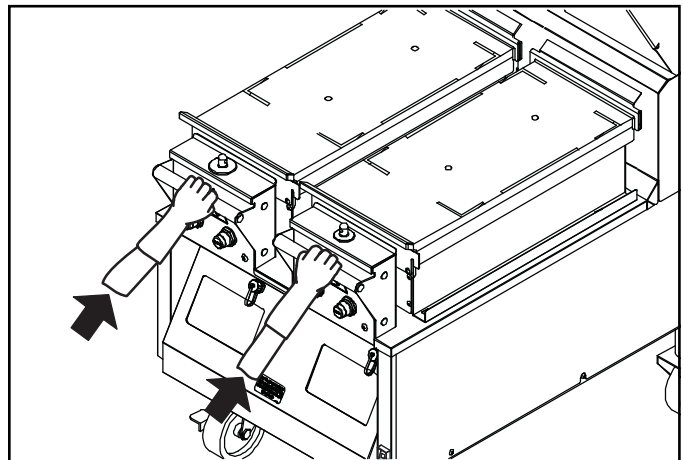

Figure-119

27. To clean the lower plate sides, raise the lower platen. See Figure 120.

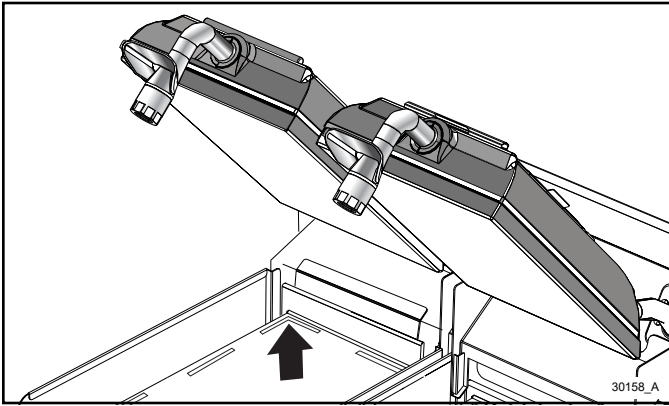

Figure-120

28. Once the platen has raised, put the multi-use tool pad on the multi-use tool. Spray the multi-use tool pad with grill cleaner. See Figure 121.

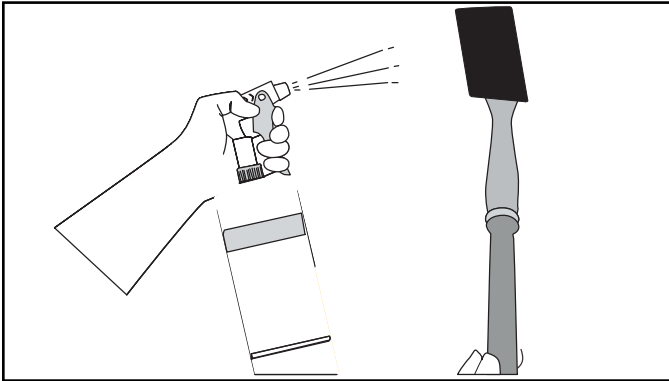

Figure-121

29. Scrub the lower platen sides. Repeat until the sides are fully covered. See Figure 122.

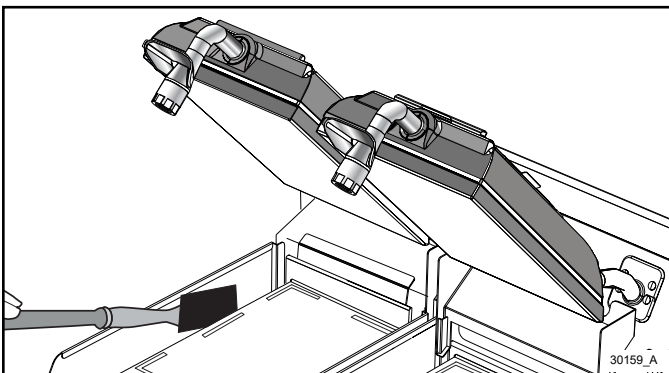

Figure-122

30. Remove and empty the grease cans and take them to the three-compartment sink. Leave them at the sink until the grill cleaning is finished. See Figure 123.

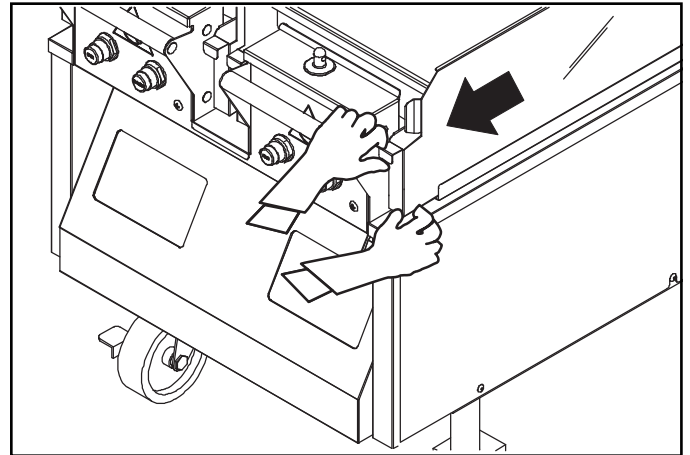

Figure-123

31. Remove the rear grease guard and take it to the three-compartment sink to wash, rinse, and sanitize. See Figure 124.

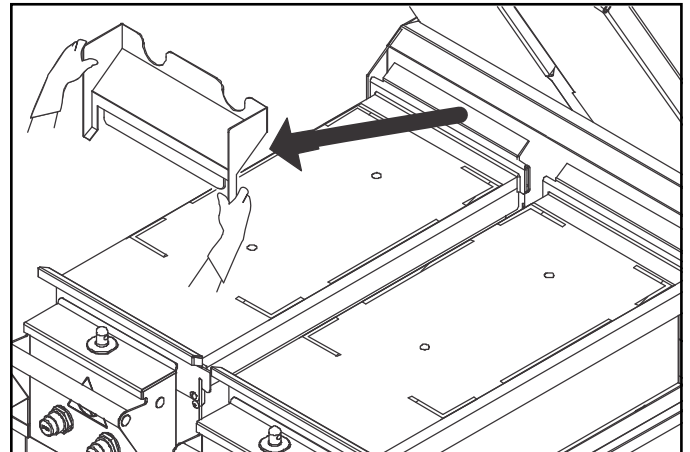

Figure-124

32. Wipe the outer edges of the lower plate. See Figure 125.

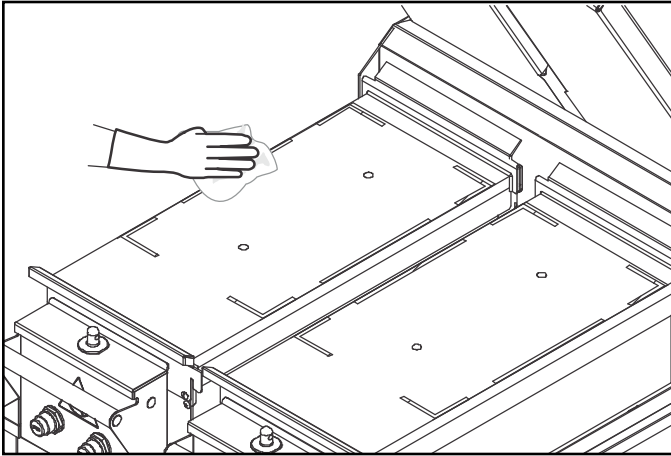

Figure-125

33. Continue cleaning through the Clean mode until the lower plate raises.

34. Once the lower plate is raised, spray the multi-use tool pad with grill cleaner and repeat until the sides are fully covered. See Figure 126.

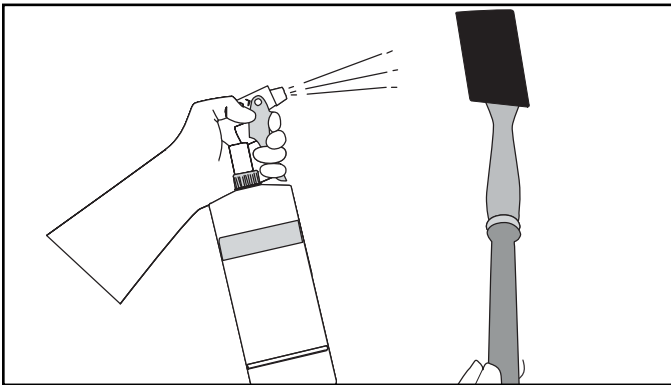

Figure-126

35. Remove the multi-use tool pad from the flat paddle tool and snap on the sanitizer-soaked universal pad. Clean in between and behind the platens and surrounding areas, such as the hood and bullnose. See Figure 127.

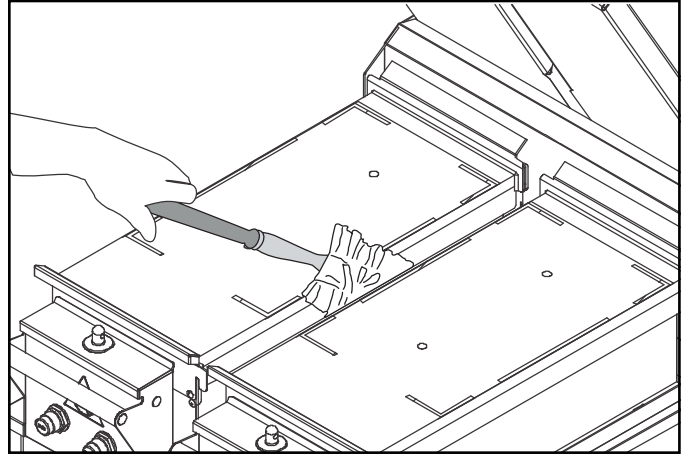

Figure-127

36. With the grill pulled out, wipe down the front and back areas of the grill with the universal pad. See Figure 128.

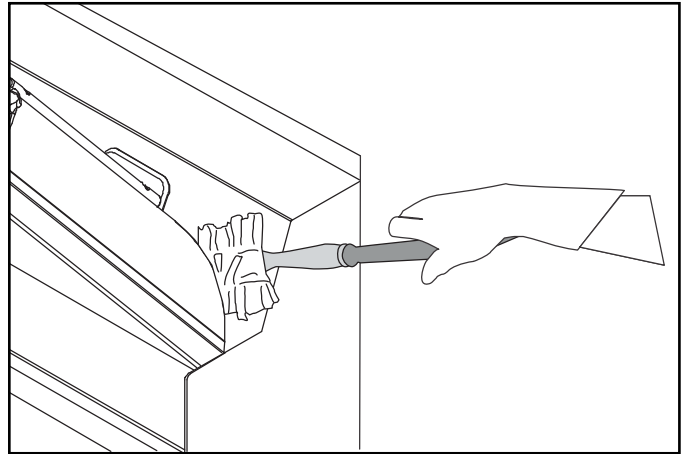

Figure-128

37. Rinse the upper platens and lower plates with a clean, sanitizer-soaked grill cloth. Also rinse the surrounding areas such as the hood, bull nose, and backslash. See Figure 129.

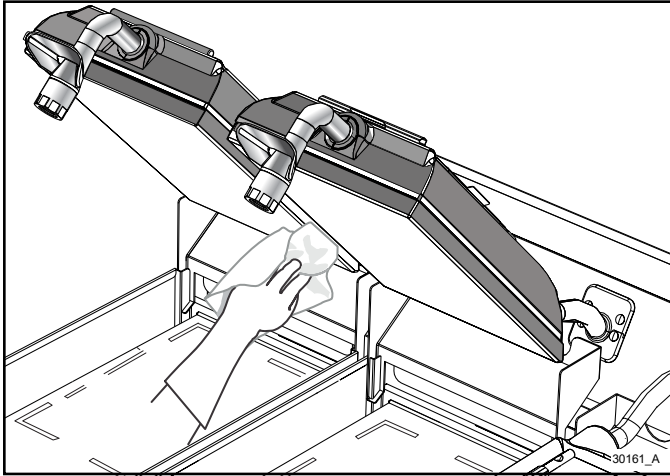

Figure-129

38. Remember to use a clean side of the cloth with each wiping. Discard the grill cloth in the soiled towel pail.

39. Once the clean mode is completed. Push the grill back into place.

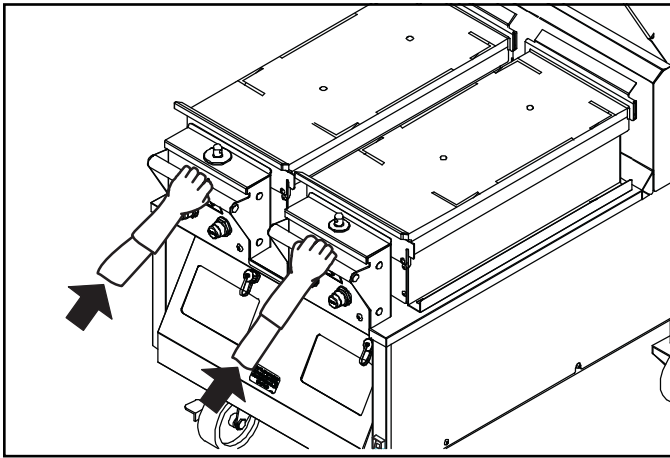

Figure-130

40. Reinstall the rear grease guard after it has been washed and rinsed. See Figure 131.

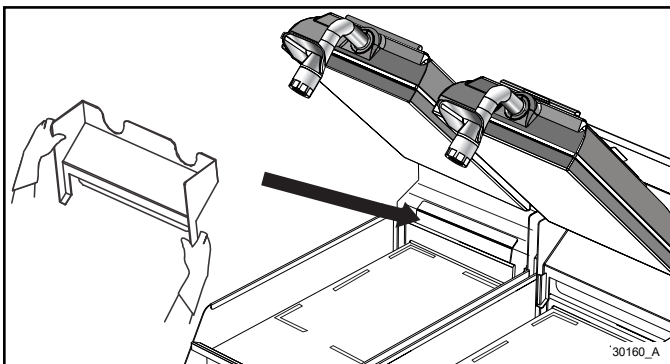

Figure-131

41. Reinstall the upper release sheets prior to use. See Figure 132.

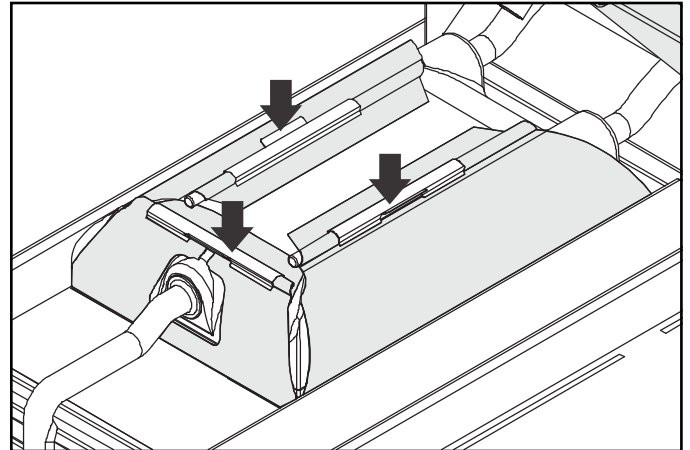

Figure-132

**Note:** Reverse the cooking side of the release sheets on a daily basis (example: black side on odd days; grey or brown side on even days).

42. Using a sundae spoon, distribute two level spoonfuls of soy adhesion flakes over a warm 3 ft. (1 m) lower grill surface, allowing the flakes to melt. Spread on the cooking zone with a clean squeegee. See Figure 133.

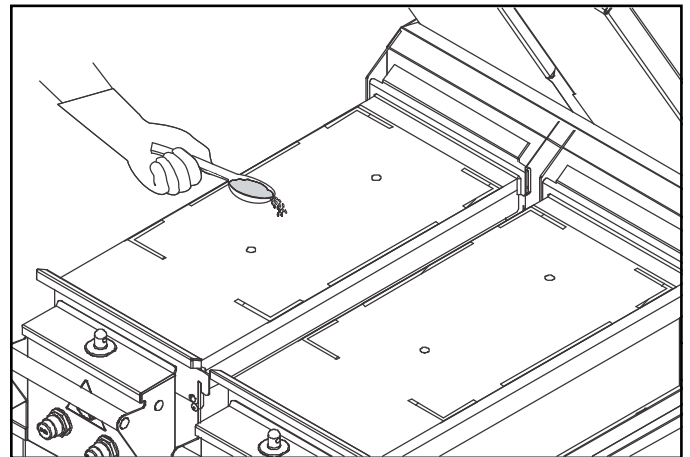

Figure-133

43. Install the lower release sheets. See Figure 134.

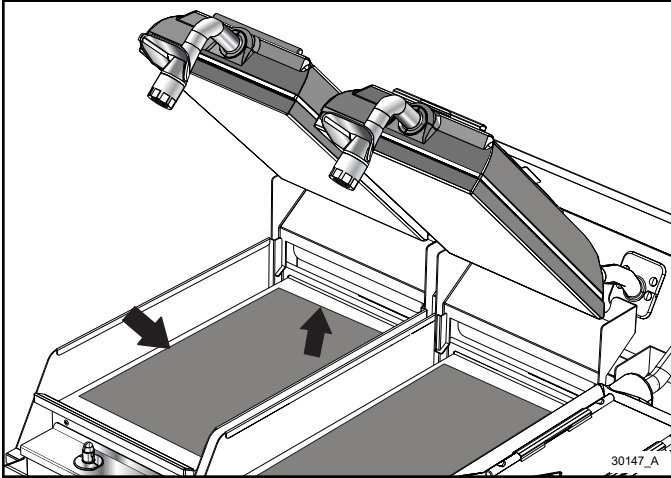

Figure-134

44. Squeegee the air bubbles and wrinkles out of each release sheet. See Figure 135.

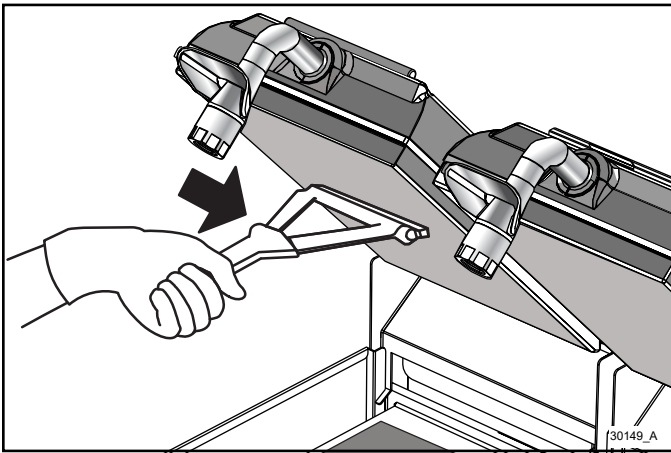

Figure-135

45. Place the fan interlock switch in the OFF position if the restaurant is closing; otherwise, return it to the appropriate setting for cooking. See Figure 136.

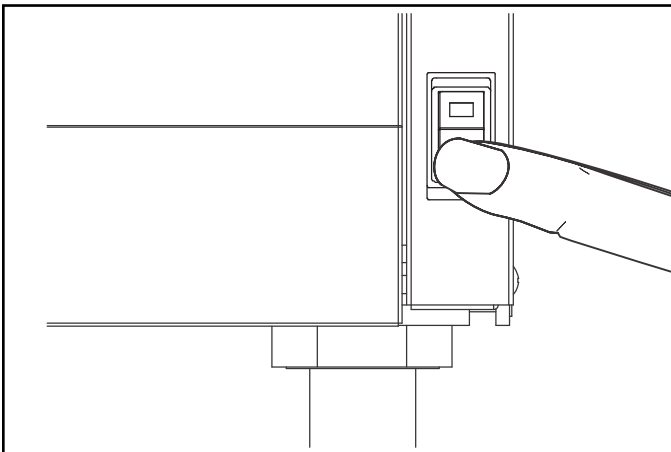

Figure-136

46. Wash, rinse and sanitize the rear grease guard and grease cans at the three-compartment sink. Reinstall the grease cans. See Figure 137.

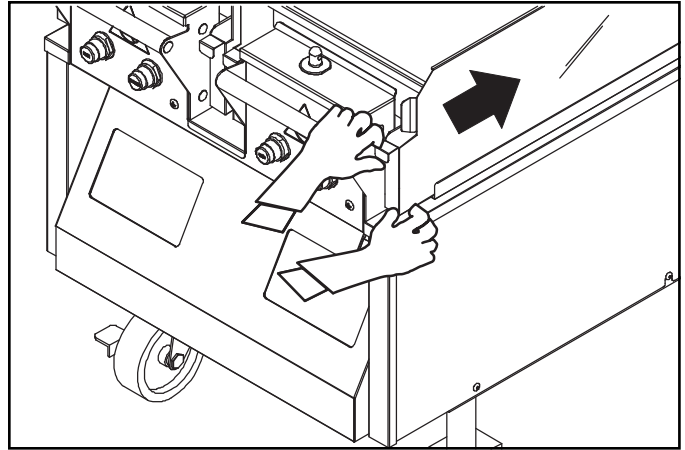

Figure-137

47. Bring the cleaning tools to the three-compartment sink. Rinse or launder the mop sock; then place it in a clean sanitizer pail. Once the grill pad and multi-use tool pad have cooled, remove and wash and rinse them thoroughly at the three-compartment sink. Allow to air dry.

48. Flip the grill pad over and replace on the tool for the next grill cleaning.

49. Wash, rinse, and sanitize all of the utensils and tools used to clean the grill at the three-compartment sink. See Figure 138.

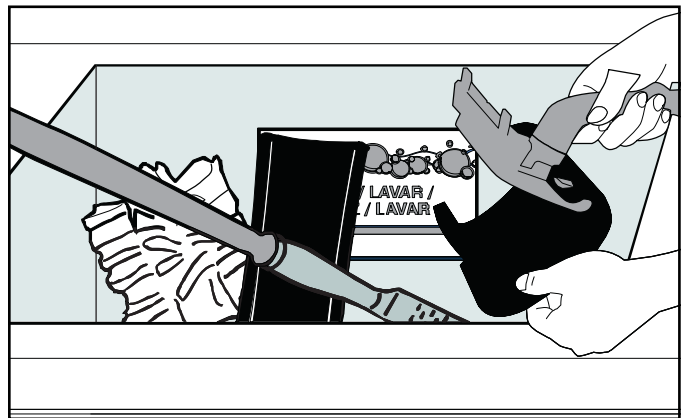

Figure-138

**Note:** Reverse the cooking side of the release sheets on a daily basis (example: black side on odd days; grey or brown side on even days).

50. Leave the upper platens in the OPEN position overnight.

## CLEANING PROCEDURE-24 HOUR STORES (WITH LOWER RELEASE SHEETS)

1. Clean the grill using the daily cleaning procedures on pages 56–64.
2. After the grill pad has cooled, remove, wash, and rinse it thoroughly at the three-compartment sink. Turn the grill pad over and reinstall it on the grill pad holder.
3. Wash, rinse, and sanitize all utensils and tools used to clean the grill at the three-compartment sink.
4. The grill is now ready to use.

## DAILY CLEANING PROCEDURES (WITHOUT LOWER RELEASE SHEETS)

**Note:** This manual contains separate procedures for grills that use lower release sheets and for grills that do not use lower release sheets. Use the procedures appropriate for your grill.

If your grill uses lower release sheets, go to page 56.



**CAUTION!** Never use cold water or ice to cool the upper platen or the lower grill plate. Failure to comply may result in equipment damage.

- Never use grill screens on the upper platen or the lower grill plate.
  - Never allow the grill scraper or abrasive cleaning materials to come in contact with the release sheet.
1. Raise the upper platen to the OPEN position by pressing the red RAISE button. See Figure 139.

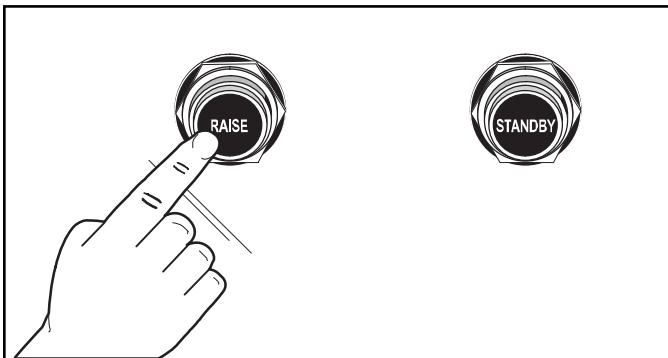

Figure-139



**CAUTION!** Never use force to raise the upper platen. Damage to components may result. Only use the RAISE button to open the upper platen.

2. Press the menu key until the clean key is displayed.
  3. Press the clean key .
  4. Press the full clean key .
  5. Gather the necessary cleaning supplies while the grill is cooling down:
    - Kay® grill cleaning pad holder
    - Kay® grill cleaning pad
    - Kay® Hi-temp tool w/flat paddle attachment
    - Flat paddle multi-use tool
    - Flat paddle universal pad
    - Kay® QSR heat-activated grill and toaster cleaner (HAGTC)
    - Heat-resistant gloves (14 in. length)
    - Kay® hi-temp tool with double-sided bristle brush
    - Squeegee
    - Sundae spoon
    - Release sheet storage tray
    - Soy adhesion flakes
- When the cook surfaces reach the proper temperature for cleaning, “Cleaning in progress” will be displayed.
6. Press the next key to proceed.
  7. Put on heat-resistant gloves. See Figure 140.

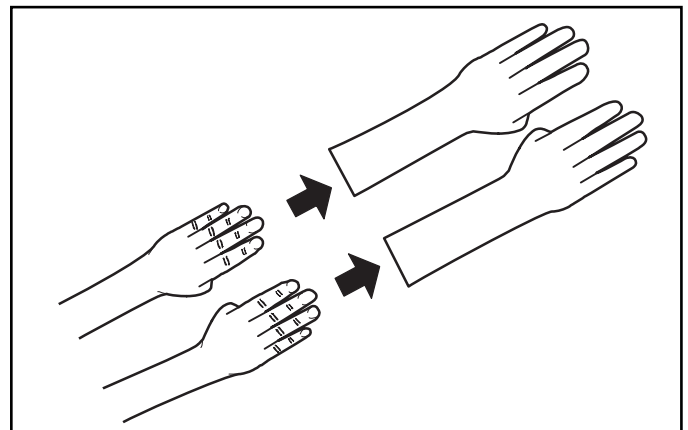

Figure-140



**CAUTION!** The upper platen surface and release sheet are very hot. To prevent burn injuries, wear heat-resistant gloves when replacing the release sheets.

8. Wipe the exposed surface of the release sheets with a clean, sanitizer-soaked grill cloth. See Figure 141.

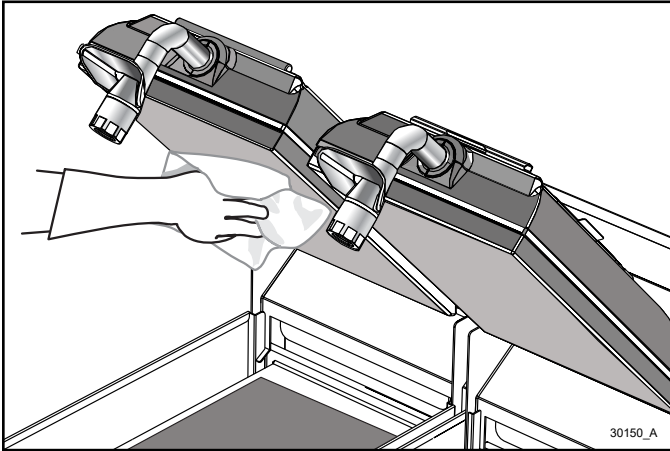

Figure-141

9. Spray a clean, sanitizer-soaked grill cloth with one spray of grill cleaner. See Figure 142.

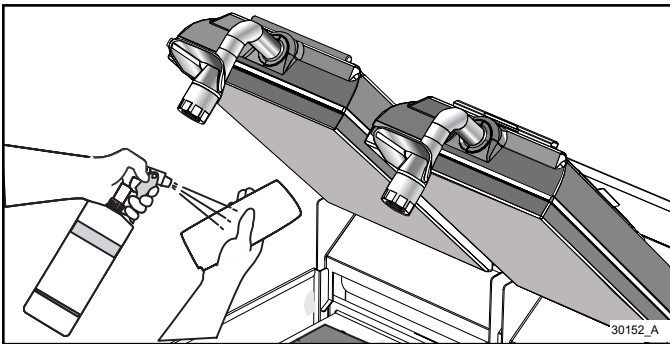

Figure-142

10. Use the sanitizer-soaked grill cloth to wipe clean the exposed surfaces of the upper release sheets, including the sides. Repeat the cleaning for the lower release sheets. See Figure 143.

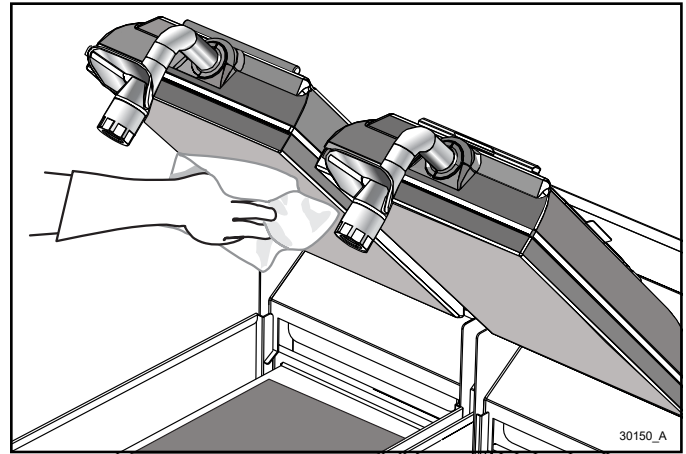

Figure-143

11. Rinse the upper release sheets with a separate sanitizer-soaked grill cloth. Wipe until the grill cleaner residue has been fully removed. See Figure 144.

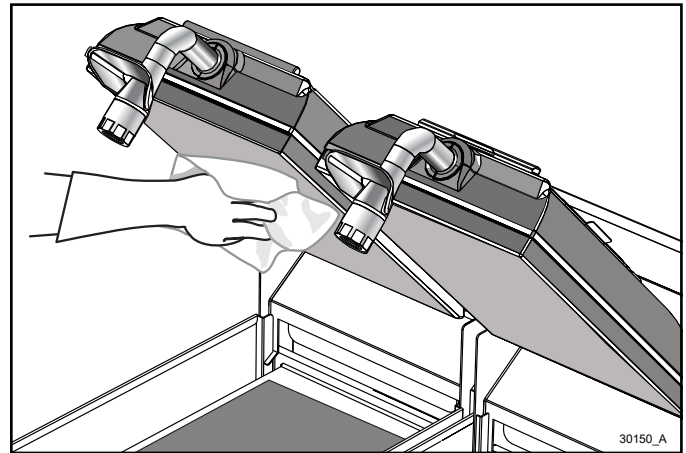

Figure-144

12. Remove the release sheet locking clips and the upper release sheets. Wash and rinse the clips in the three-compartment sink. If necessary, soak them in a hot solution of SolidSense APSC to remove carbon accumulation. See Figure 145.

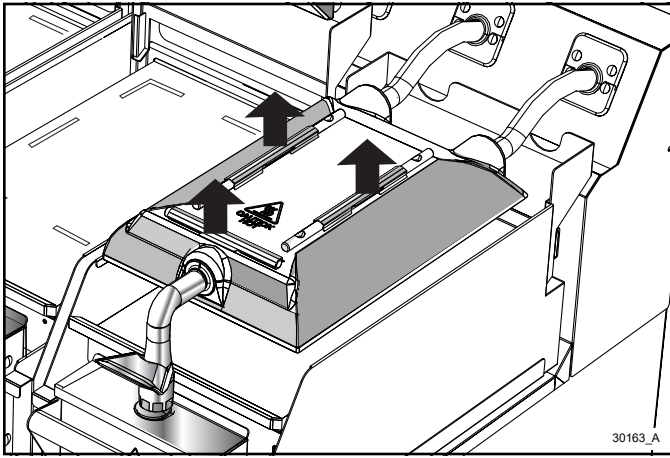

Figure-145

13. Place all of the release sheets clean side down flat on the release sheet storage tray. See Figure 146.

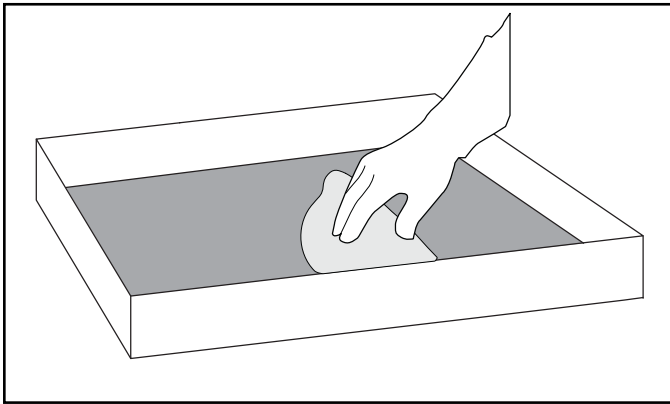

Figure-146

14. Spray a clean, sanitizer-soaked grill cloth once with grill cleaner. Wipe the soiled side of the release sheet until clean. See Figure 147.

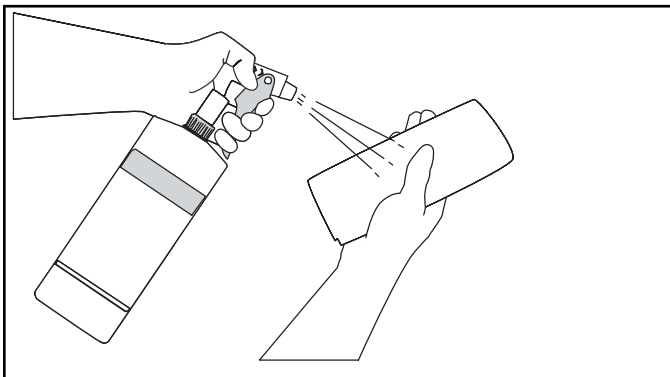

Figure-147

15. Rinse with a separate clean, sanitizer-soaked grill cloth to rinse off the remaining grill cleaner. Repeat for all of the release sheets. See Figure 148.

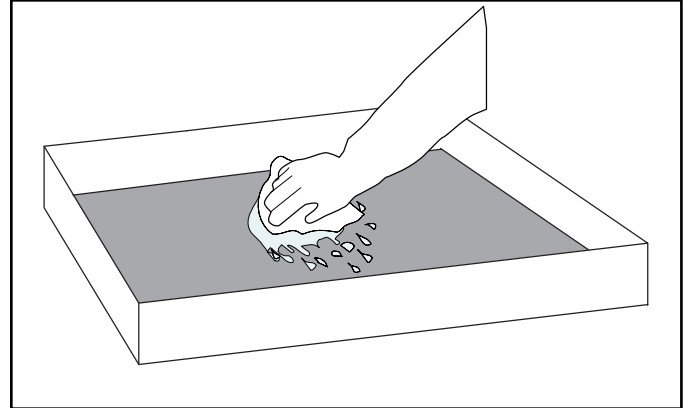

Figure-148

16. Remove the rear grease guard and take it to the three-compartment sink to wash, rinse, and sanitize. See Figure 149.

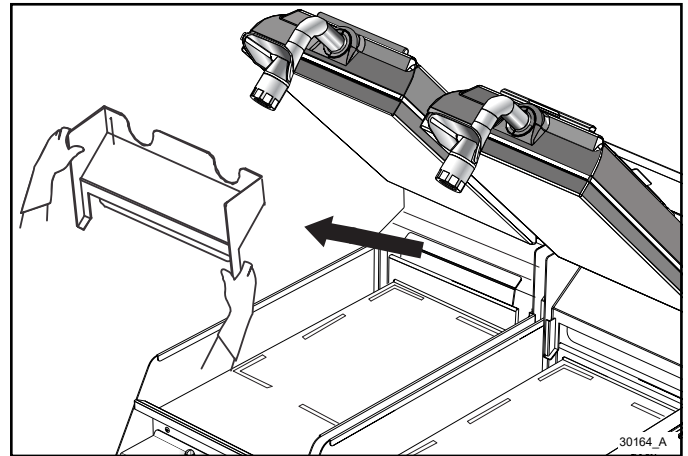

Figure-149

17. Spray the upper platens with grill cleaner, starting with the sides and back. If you have three upper platens, lower the middle platen first to easily access the adjoining sides of the right and left platens.

18. After spraying the sides, spray the surface of each upper platen three times to cover the bottom, middle, and top. See Figure 150.

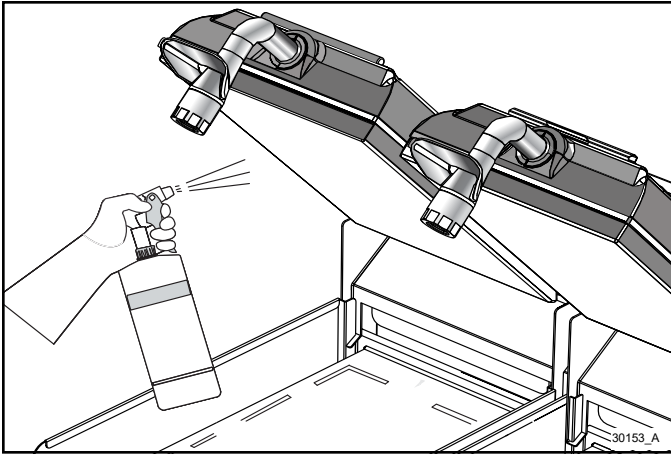

Figure-150

19. Firmly attach the cleaning pad to the Kay grill cleaning pad holder.



**NOTICE! DO NOT** use metal scrapers, abrasive pads, screens, or wire brushes. Damage to components may result.

20. Apply the grill cleaner to the platen surfaces, starting from the right platen to the left platen.
21. Using the Kay grill cleaning pad holder, distribute the grill cleaner around the upper platens to ensure full coverage. See Figure 151.

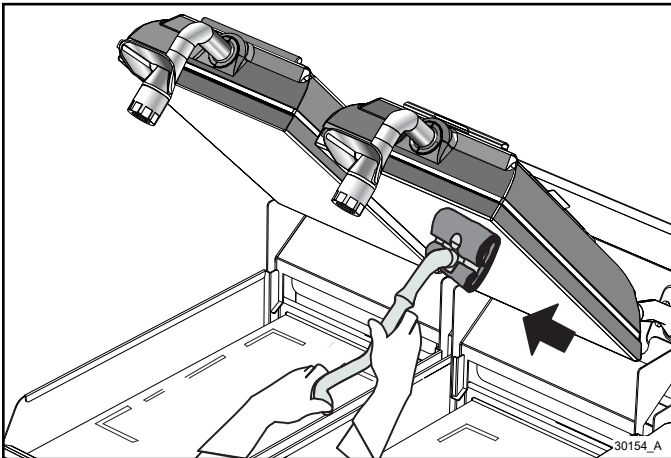

Figure-151

22. Remove the cap from the dosing bottle and squeeze the bottle to fill the dosing cup as marked  $\frac{1}{2}$  oz. See Figure 152.

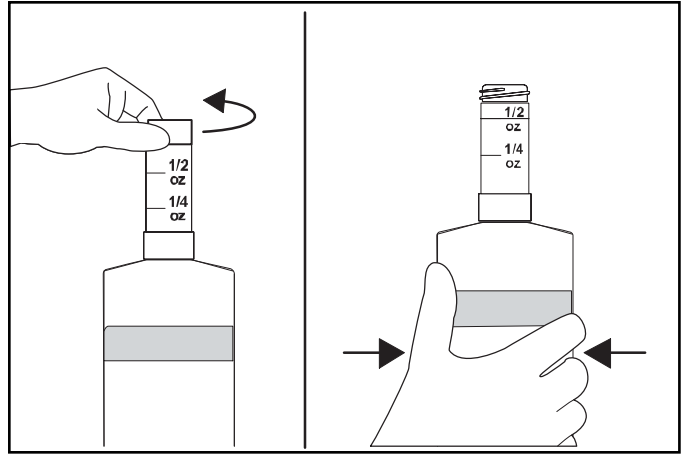

Figure-152

23. Beginning on the left lower plate, pour the dosed  $\frac{1}{2}$  oz. of grill cleaner from left to right in the shape of an arched M. Repeat for each lower plate until all of them are fully covered. See Figure 153.

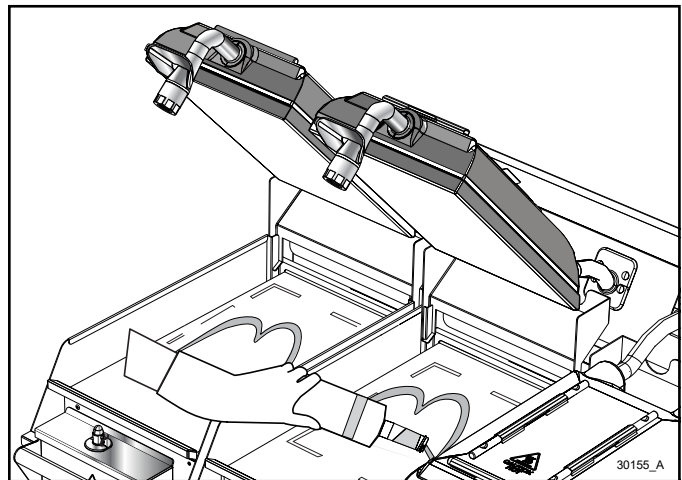

Figure-153

24. Apply the grill cleaner to the back side of the platens, from the right platen to the left platen.

25. Spread the grill cleaner thoroughly on the lower surface to ensure full coverage. See Figure 154.

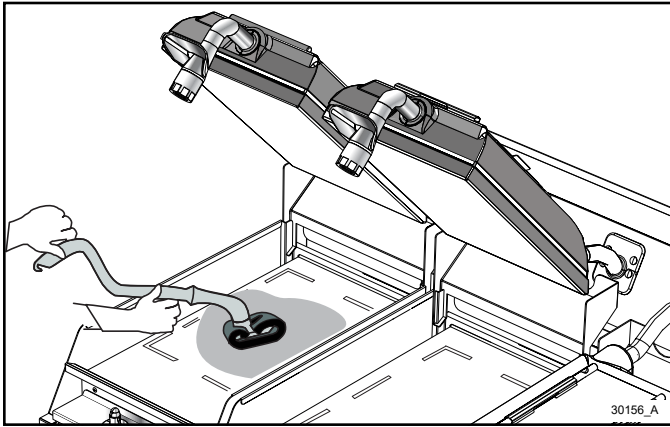

Figure-154

26. Scrub the upper and lower plate with the grill cleaning tool and pad. See Figure 155.

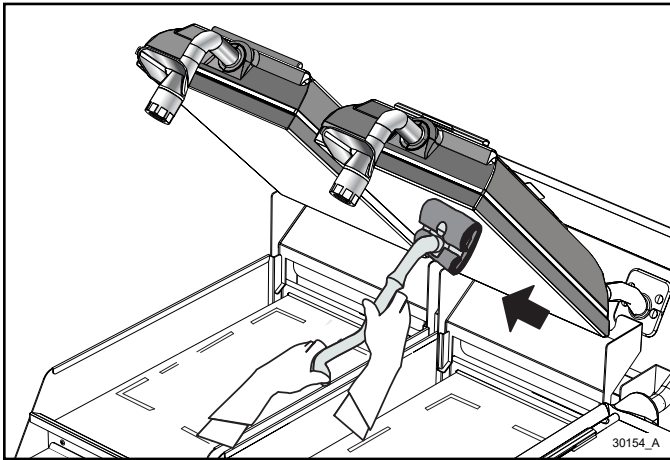

Figure-155

27. If needed, scrub the upper platen with the Kay double-sided grill brush. See Figure 156.

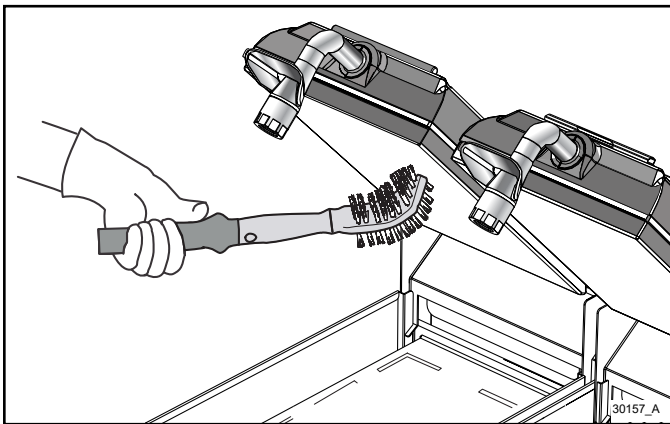

Figure-156

28. Remove and empty the grease cans and take to the three-compartment sink. Leave at the sink until the grill cleaning is finished. Continue through clean mode until the lower plate raises. See Figure 157.

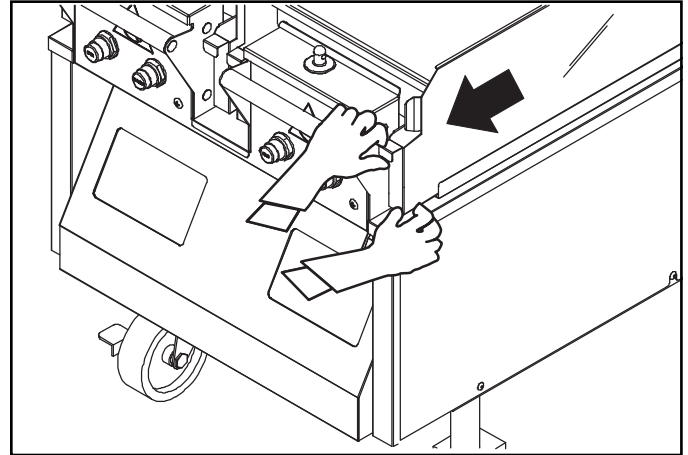

Figure-157

**Note:** Allowing the grill cleaner to sit on the grill surfaces will require less effort and time to scrub heavy soil buildup and achieve a clean grill.

29. To clean the lower plate sides, pull out the grill and raise the lower plates. See Figure 158.

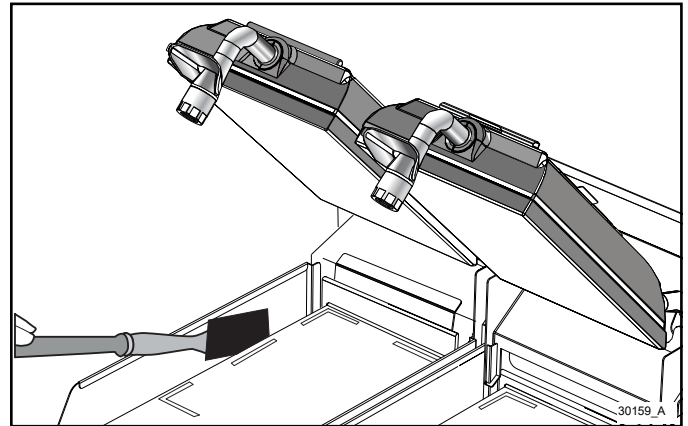

Figure-158

30. Once the platen has raised, Put the multi-use tool pad on the flat paddle tool. Spray the multi-use tool pad with grill cleaner. See Figure 159.

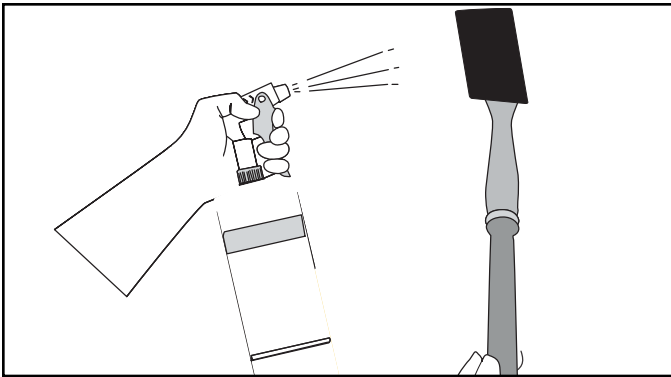

Figure-159

31. Scrub the lower plate sides. Repeat until the sides are fully covered. See Figure 160.

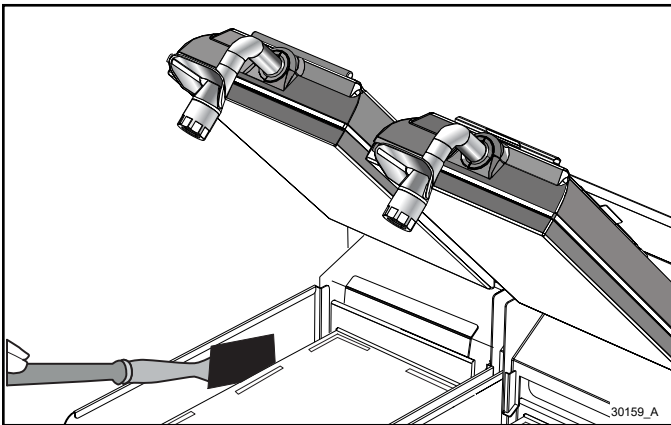

Figure-160

32. Remove the multi-use tool pad from the flat paddle tool and snap on the sanitizer-soaked universal pad. Clean in-between and behind the platens and surrounding areas, such as the hood and bullnose. See Figure 161.

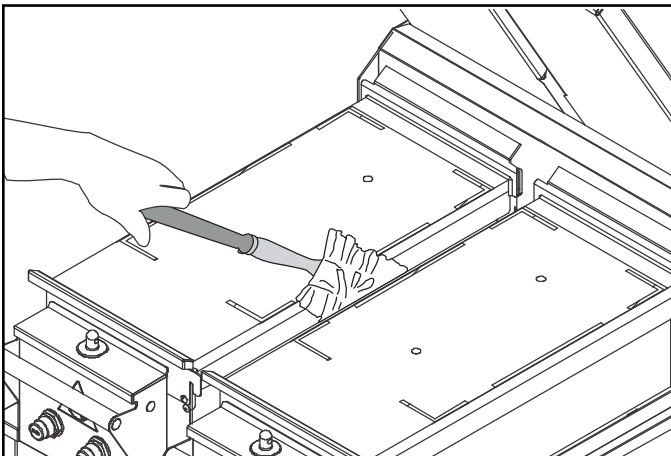

Figure-161

33. With the grill pulled out, wipe down the front and back areas of the grill with the universal pad. See Figure 162.

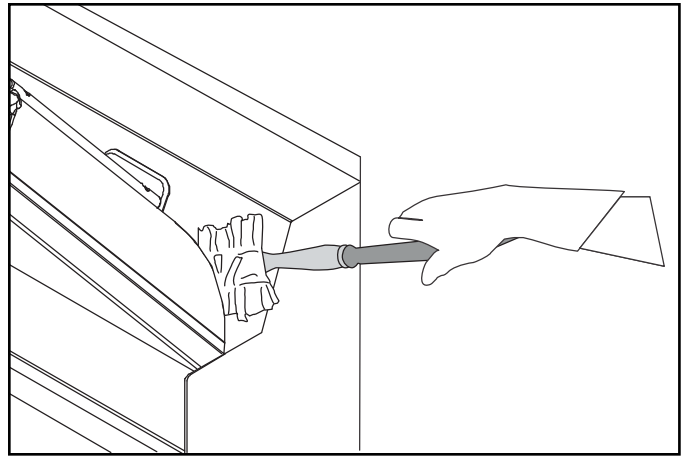

Figure-162

34. Rinse the upper platens and lower plates with a clean, sanitizer-soaked grill cloth. Also rinse the surrounding areas, such as the hood, bull nose, and rear grease guard. See Figure 163.

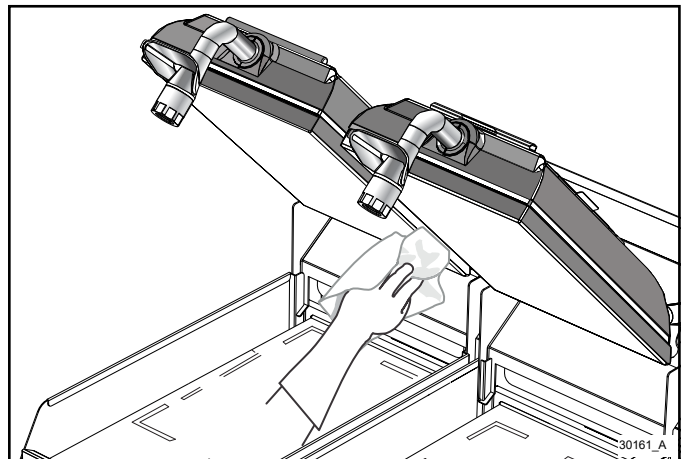

Figure-163

35. Remember to use a clean side of the cloth with each wiping. Discard the grill cloth in the soiled towel pail.

36. Push the grill back into place. See Figure 164.

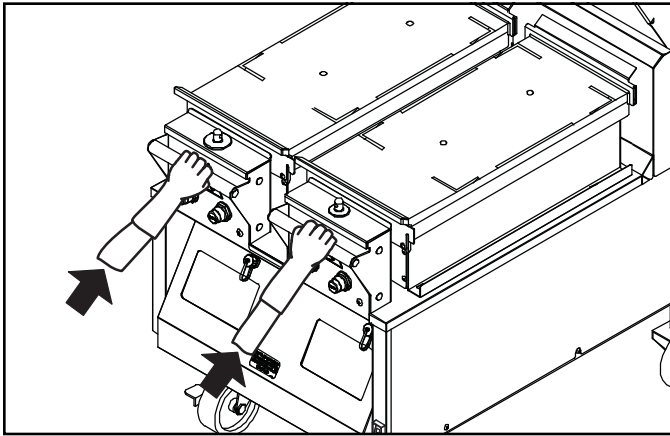

Figure-164

37. Reinstall the upper release sheets prior to use. See Figure 163.

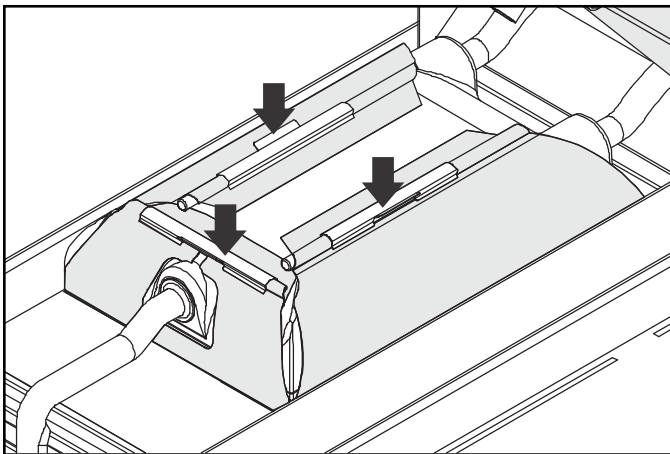

Figure-165

**Note:** Reverse the cooking side of the release sheets on a daily basis (example: black side on odd days; grey or brown side on even days).

38. Wash and rinse the grease pans in the three-compartment sink. See Figure 166.

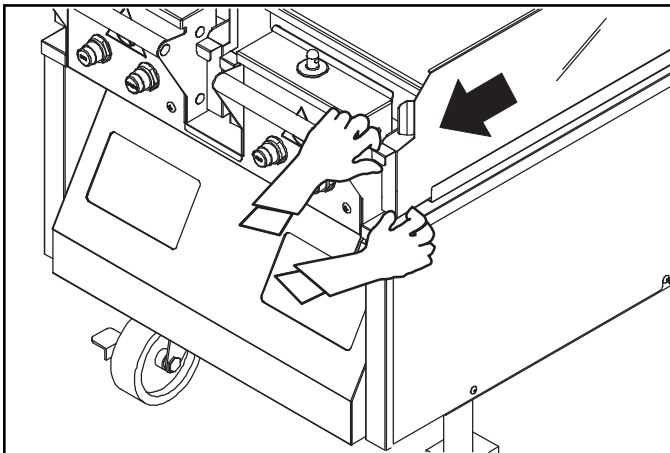

Figure-166

39. Reinstall the grease pans. See Figure 167.

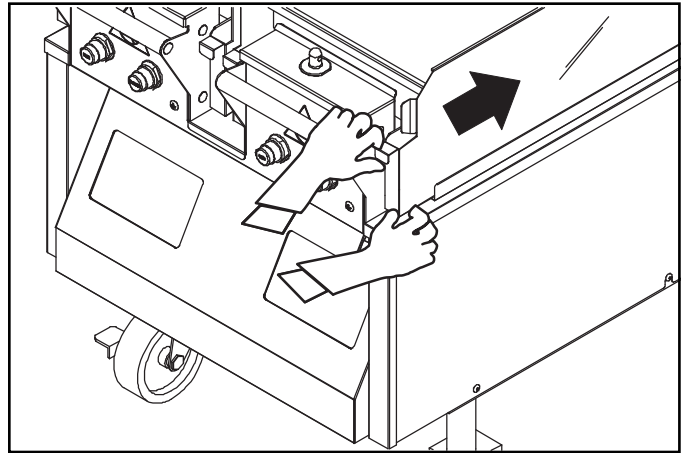

Figure-167

40. Reinstall the rear grease guard. See Figure 168.

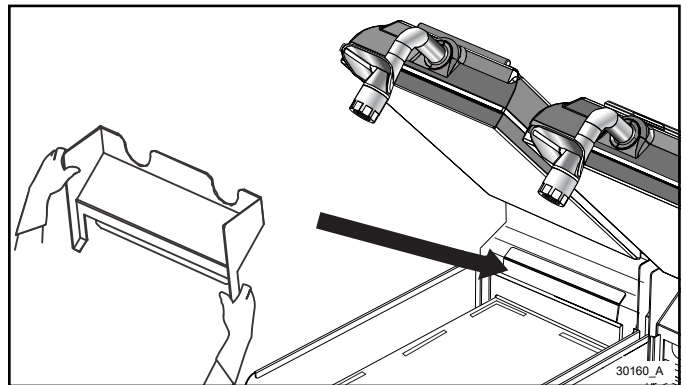

Figure-168

41. Bring the cleaning tools to the three-compartment sink. Rinse or launder the universal pad; then place it in a clean sanitizer pail. Once the grill pad and universal pad have cooled, remove and wash and rinse them thoroughly at the three-compartment sink. Allow them to air dry.

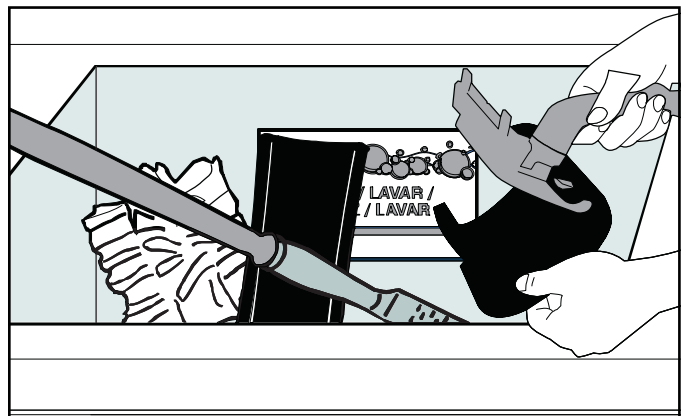

Figure-169

42. Flip the grill pad over and replace it on the tool for the next grill cleaning.

43. Wipe the remaining grill surfaces with a clean sanitizer-soaked grill cloth.

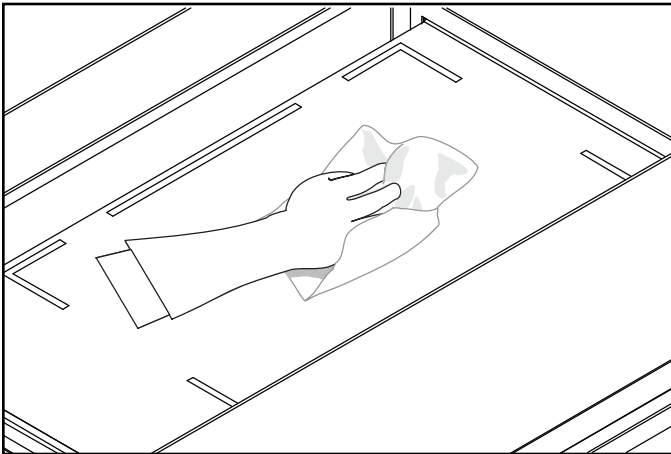

Figure-170

44. Apply a light coat of fryer cooking oil to the entire lower grill surface.
45. Leave the upper platens in the OPEN position overnight.
46. After the grill pad has cooled, remove it from the pad holder and wash and rinse it thoroughly at the three-compartment sink. Turn the grill pad over and re-install it on the grill pad holder.

### CLEANING PROCEDURE-24 HOUR STORES (WITHOUT LOWER RELEASE SHEETS)

1. Clean the grill using the daily cleaning procedures on pages 65–71.
2. After the grill pad has cooled, remove, wash, and rinse it thoroughly at the three-compartment sink. Turn the grill pad over and reinstall it on the grill pad holder.
3. Wash, rinse, and sanitize all utensils and tools used to clean the grill at the three-compartment sink.

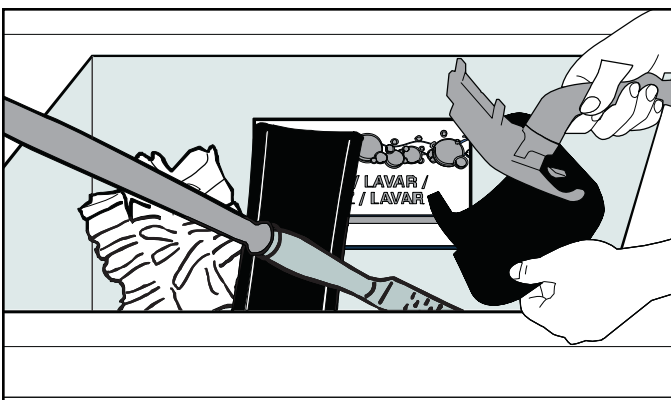

Figure-171

4. The grill is now ready to use.

### QUARTERLY RECOVERY MODE PROCEDURES

(Follow the McD Grill Recovery Cleaning Procedure from EcoLab)

**Note:** Use new and clean tools for recovery application.

**Note:** PPE (gloves, apron and a face shield) should be worn when following the cleaning procedure due to the high temperature of the grill.

**Important!** : Remove the upper and lower release sheets prior to Recovery procedure.



**CAUTION!** Do not remove the grill filters. Cleaning without the filters can cause severe burns or fire.

1. Ensure Recovery mode programming has been completed on the grill before initiating cleaning.
2. Press the Recovery key  to enter the recovery mode. See Figure 172.

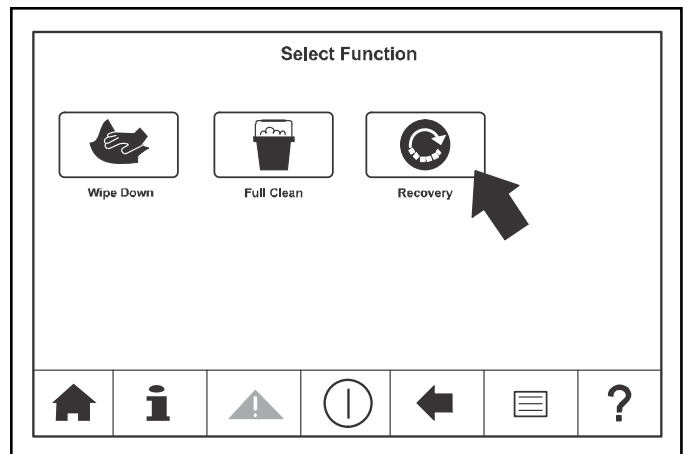

Figure-172

3. The recovery mode is on. See Figure 173.

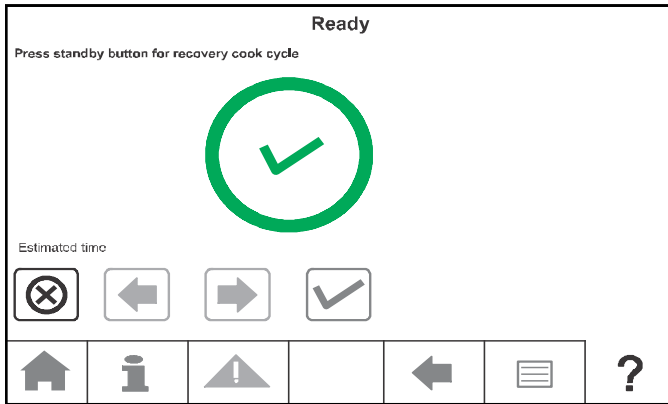

Figure-173

4. Press the STANDBY button to start the recovery process. See Figure 174.

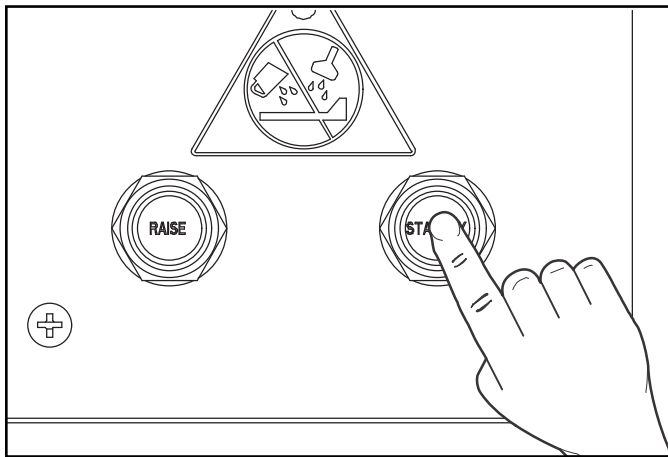



Figure-174

5. Select the Recovery setting  from the grill interface and allow the grill to cool before cleaning. Do not turn the fan interlock off. Allow the grill to reach 285°F before cleaning. A temperature of 285°F is critical to maximize the effectiveness of the cleaning product.

6. Put on heat-resistant gloves. See Figure 175.

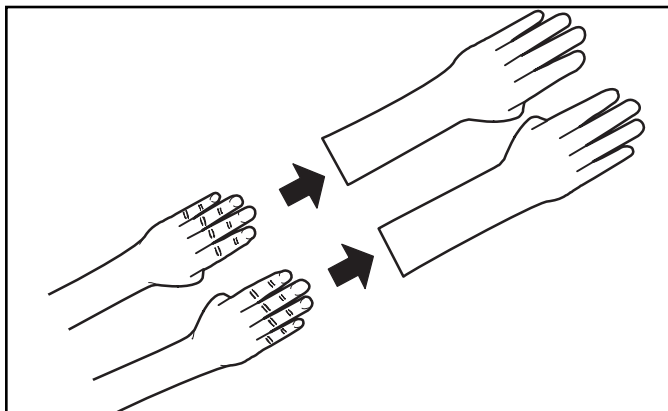

Figure-175

7. Remove and empty the grease cans, then rinse and replace. See Figure 176.

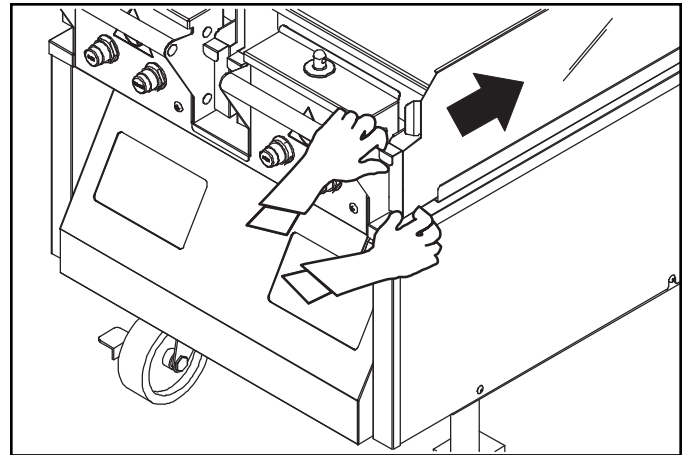

Figure-176

8. Remove all of the clips, bars, and release sheets before the recovery cleaning. See Figure 177.

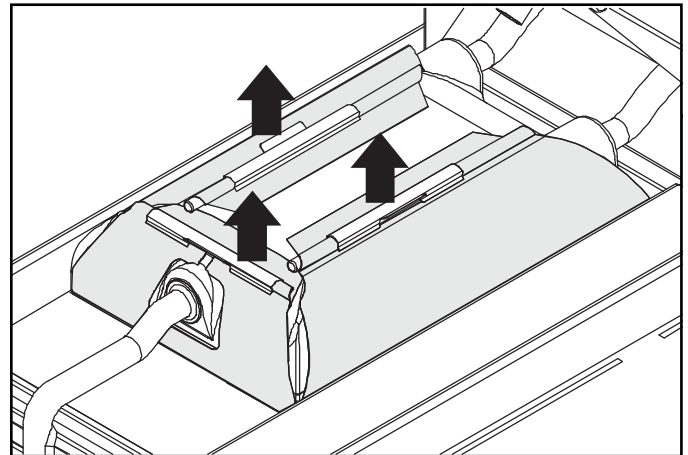

Figure-177

9. Clean the release sheets (see "O&T manual" or "grill cleaning key card" for details). See Figure 178.

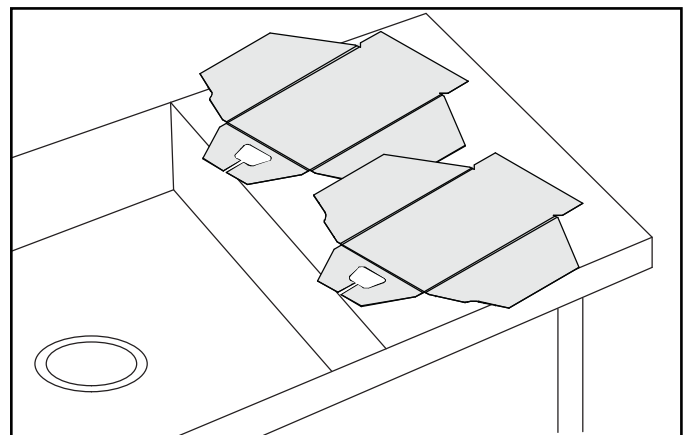

Figure-178

10. Take the clips and bars to the three-compartment sink; then wash, rinse and sanitize them.
11. Gather the materials for cleaning while the grill is cooling down.
12. When the grill has reached 285°F, it is ready for cleaning.
13. Put Personal Protective Equipment on (examples: gloves, face shield, and apron). See Figure 179.

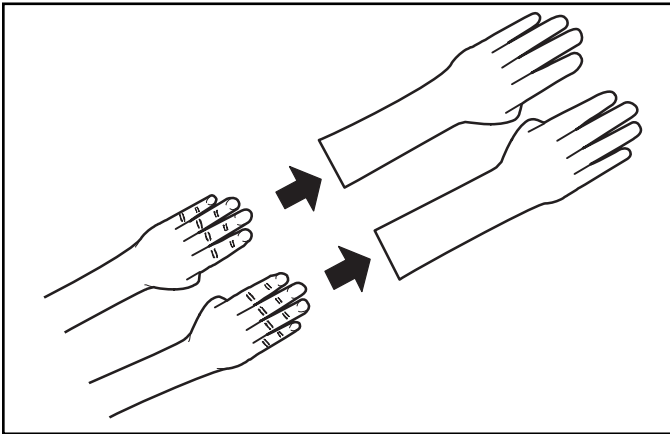

Figure-179

14. Wipe the upper platens and lower plates with a clean, sanitizer-soaked grill cloth before cleaning. Discard the cloth into the soiled towel pail after use. See Figure 180.

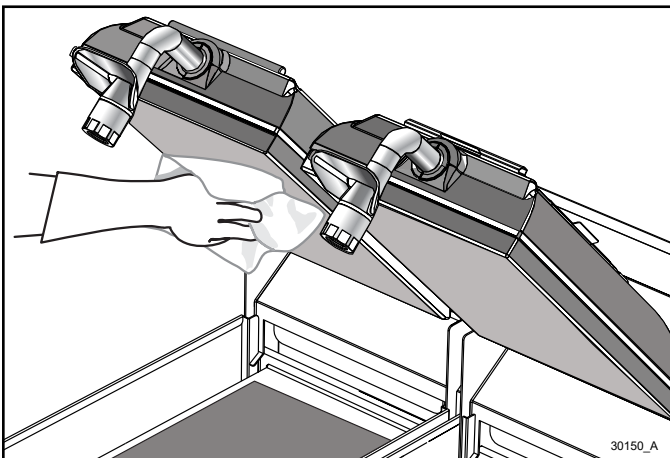

Figure-180

15. Scrape off as much carbon buildup as possible from all surfaces of the upper platens (especially the back and corners) with the scraper.

16. With all of the platens up, apply sufficient Kay QSR heat activated grill & toaster cleaner to the grill tool pad and coat the edges of the upper platens with the product. See Figure 181.

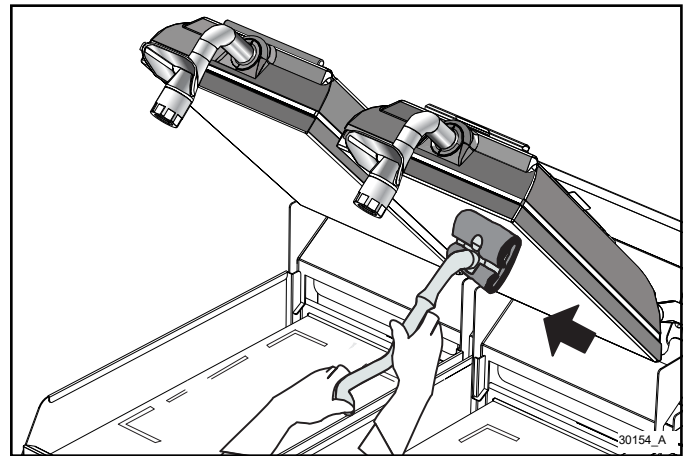

Figure-181

**Note:** If needed, pull the grill out from the wall and stand to the side of the grill to reach the back side of the upper platens. Pour additional Kay QSR heat activated grill & toaster cleaner onto a grill cloth and apply it to hard to-reach areas. See Figure 182.

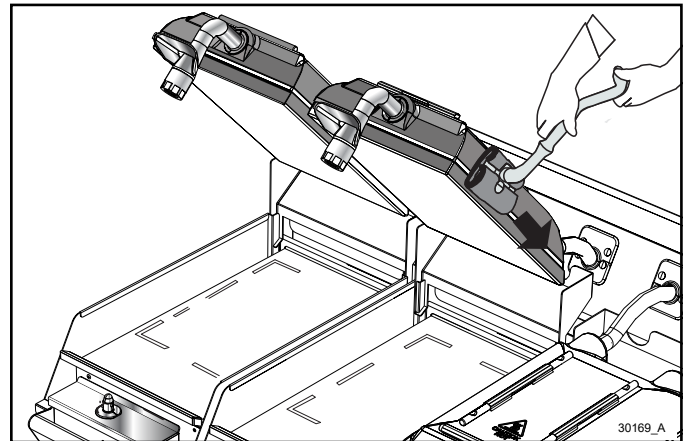

Figure-182

17. Use a separate bottle of Kay QSR heat-activated grill & toaster cleaner and remove the cap. Evenly pour the entire bottle of cleaner onto the lower plate surface of the grill along with the remainder of the first bottle. See Figure 183.

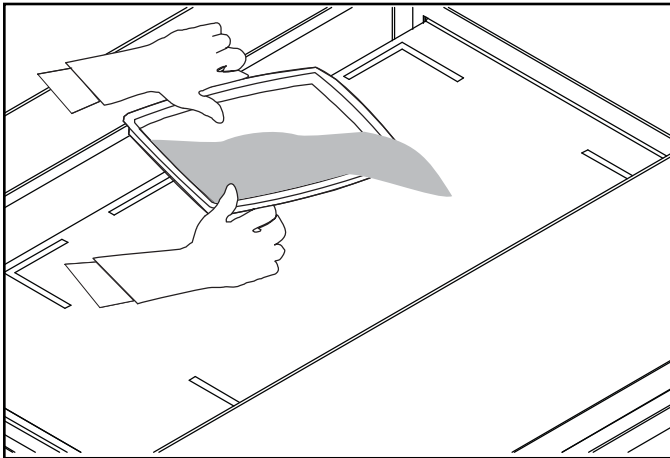

Figure-183

**Note:** Make sure to coat the entire surface of the lower plate. Use the Kay grill cleaning pad holder with the pad if needed to spread product for full coverage of the grill surface. See Figure 184.

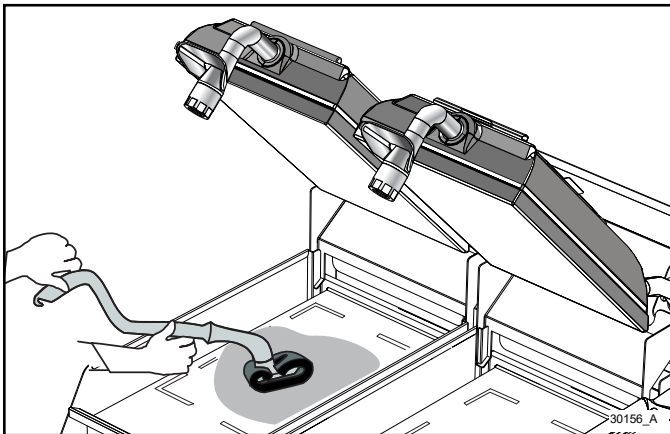

Figure-184

18. Lower both of the upper platen onto the lower plate surface coated with Kay QSR heat-activated grill & toaster cleaner.
19. Allow the upper and lower plates to soak for a full cycle-approximately 17 minutes.

20. After the cycle is completed and the upper platens have risen, scrub the flat surface, edges, and sides of the upper platens with the Kay double sided grill brush. Scrub until the soil liquefies. See Figure 185.

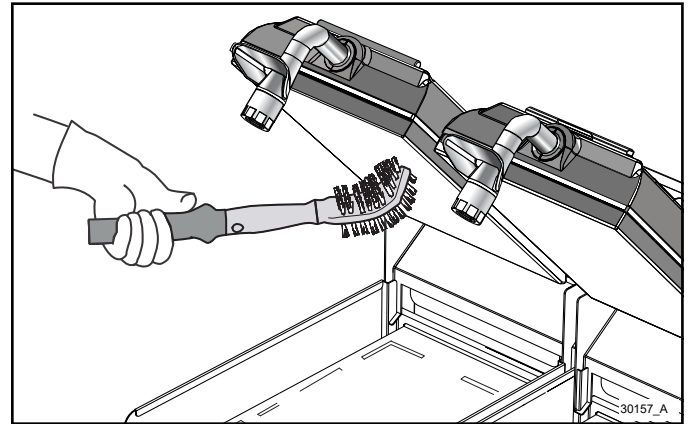

Figure-185

**Note:** In order to scrub all of the edges of the upper platens, one upper platen will need to be lowered to reach the inside edge of both platens with the brush.

21. Make sure to have both upper platens raised before cleaning the lower plate.
22. Scrape off carbon buildup off of all surfaces of the upper platens (especially the back and corners) with the scraper.
23. Scrub the lower cook surface and all areas using the Kay grill cleaning pad holder with the pad. See Figure 186.

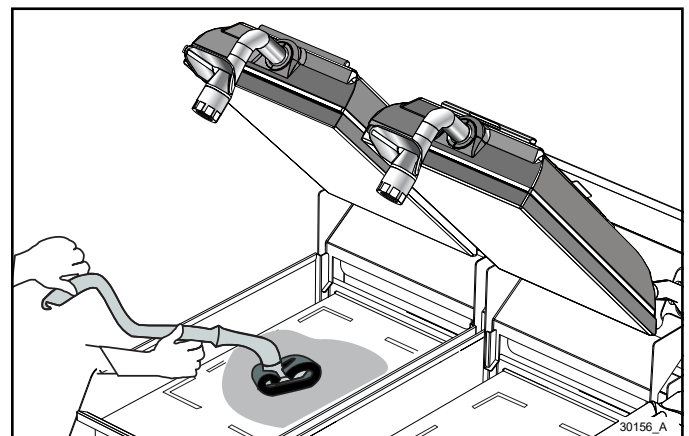

Figure-186

24. Squeegee the grill cleaner into the grease cans. See Figure 187.

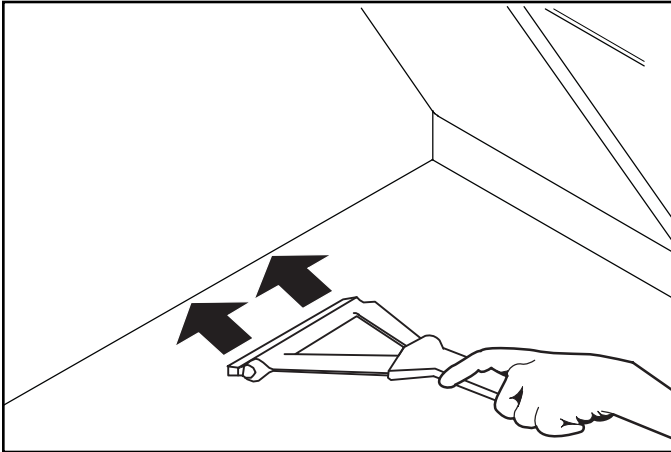

Figure-187

25. Thoroughly rinse both the upper and lower plates with clean, sanitizer-soaked grill cloths. Repeat until no residual Kay QSR heat-activated grill & toaster cleaner remains. Clean the surrounding areas such as the hood, bullnose, and backsplash with clean, sanitizer-soaked grill cloths. Discard the cloths into the soiled towel pail after use. See Figure 188.

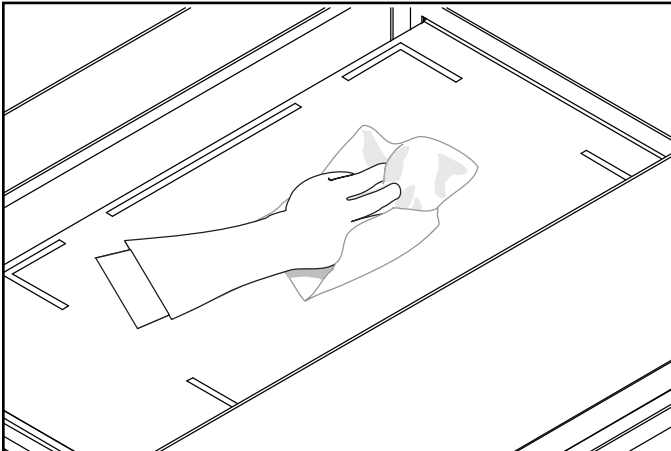

Figure-188

**Note:** In order to scrub all of the edges of the upper platens, one upper platen will need to be lowered to be able to reach the inside edge of both platens with the brush.

26. If carbon buildup remains, repeat step 13 through step 25.

27. Remove and empty the grease trough; then, rinse and replace. See Figure 189.

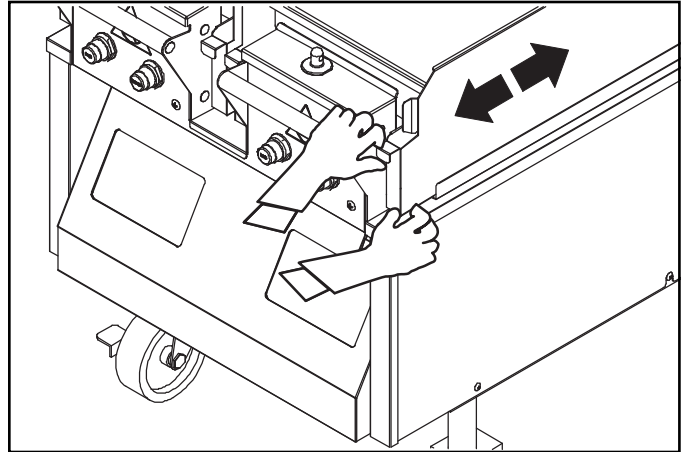

Figure-189

28. Reinstall the upper and lower release sheets (see "O&T Manual" or "Grill Cleaning Kay Card" for details). See Figure 190.

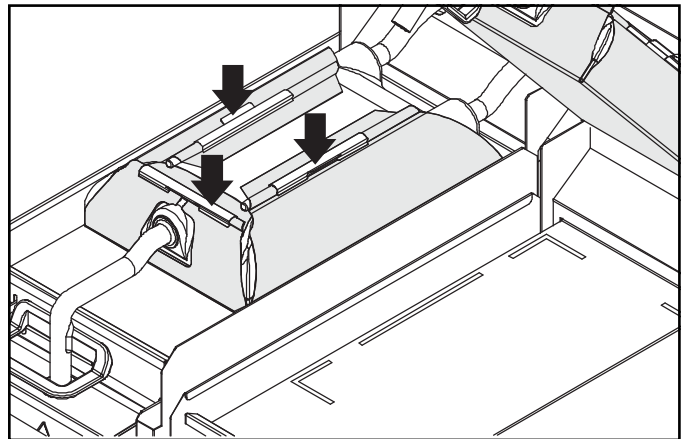

Figure-190

29. Once the grill pad has cooled, remove; wash and rinse it thoroughly at the three-compartment sink. Flip the grill pad over and replace it on the tool for the next grill cleaning.

30. Wash, rinse, and sanitize all of the utensils and tools used to clean the grill at the three-compartment sink.



**DANGER!** Improper installation, adjustment, alteration, service, or maintenance can cause property damage, injury, or death. Read the installation, operating, and maintenance instructions thoroughly before installing or servicing this equipment.



**IMPORTANT!** *Inspection, testing, and repair of electrical equipment should be performed only by qualified service personnel.*



**WARNING!** The grill should be disconnected from all electricity when servicing, except when electrical tests are required. Failure to comply may result in severe personal injury or equipment damage.



**DANGER!** Use extreme care during electrical circuit tests. Live circuitry may be exposed. Failure to follow this instruction may result in severe injury or death.



**CAUTION!** The grill must be pulled away from the wall for thorough cleaning. When returning the grill to its original position, use extreme caution to smoothly and slowly roll the grill backward into place. Failure to do so may cause the grill to tip, and will cause severe equipment damage or personal injury.

## EQUIPMENT TROUBLESHOOTING

### Entire Grill (All Models)

Problem	Probable Cause	Remedy
The exhaust hood alone does not turn on when the fan interlock switch is in the ON position.	The fan interlock switch is faulty.	Call for service.
	Loose or broken wires to switch.	Call for service.
The grill alone will not turn on when the fan interlock switch is in the ON position.	The grill breaker has tripped.	Reset the breaker.
	The grill's control voltage cord has become unplugged.	Reseat the power cord.
	The Ansul reset tripped.	Press the Ansul reset button.
	Internal component failure.	If the problem still remains, call for service.
The platen will not stay down when the STANDBY button is pressed.	The cavity where the handle latches to the latch solenoid (located at the front of the grill) is dirty.	Clean the handle foot and/or the latch solenoid post.
	Internal component failure.	If the problem still remains, call for service.
The grill displays TOO COOL.	The grill is not within the specified temperature range of the specified recipe.	Wait for the grill to reach temperature range for specified recipe.
	Three phase breaker tripped.	Reset the breaker.
	Three-phase cord has become unplugged from the wall.	Reseat the three phase plug.
The grill displays TOO HOT.	The grill is not within the specified temperature range of the specified recipe.	Wait for the grill to reach temperature range for specified recipe.
Thermocouple X is open.	Internal component failure.	Call for service.
Thermocouple X is shorted.	Three-phase cord has become unplugged from the wall.	Reseat the three-phase plug.
	Internal component failure.	If the problem still remains, call for service.
The grill is making loud whistling noise when cooking product with egg ring.	The egg ring is dirty and causing steam to escape.	Clean the egg ring.

## PRODUCT TROUBLESHOOTING

Problem	Probable Cause	Remedy
The product is undercooked or overcooked.	<p>The release material is dirty or worn.</p> <p>The upper platen or lower cook surface is not clean or has carbon buildup.</p> <p>Incorrect cook time.</p> <p>The grill's gaps are not within specification.</p>	<p>Clean and/or replace the release sheets.</p> <p>Cleaning procedures must be followed to properly clean the grill and remove carbon buildup.</p> <p>Increase or decrease the cook Time accordingly. See the Cook Time key page 35.</p> <p>Refer to the gapping procedure in the service manual.</p>
The product is not cooking evenly.	<p>The upper platen or lower cook surface are not clean or have carbon buildup.</p> <p>The release sheet material is dirty or worn.</p> <p>The grill's gaps are not within specification.</p>	<p>Cleaning procedures must be followed to properly clean the grill and remove carbon buildup.</p> <p>Clean and/or replace the release sheets.</p> <p>Refer to the gapping procedure in the service manual.</p>
Eggs are pooling to one side of the egg ring.	<p>The grill has become unlevel.</p> <p>The grill's gaps are not within specification.</p>	<p>Re-level the grill.</p> <p>Refer to the gapping procedure in the service manual.</p>
The grill displays "Lower Plate Stall," and platen comes up.	<p>The product being cooked is misshaped or out of specification.</p> <p>The wrong recipe was selected to cook.</p>	<p>Press the STANDBY button again. The product will flatten as it thaws.</p> <p>Review and select the correct recipe item. Restart the cook cycle.</p>
The product is not recognized.	<p>Carbon buildup on the upper and/or lower cook surfaces is interfering with the Auto Gap settings.</p> <p>The grill plate has become uneven.</p> <p>The wrong product is being used.</p> <p>The grill is not set in the Auto Product Recognition mode.</p>	<p>Remove the carbon and clean the upper and lower cook surfaces.</p> <p>Refer to the gapping procedure in the service manual.</p> <p>Ensure correct product and settings.</p> <p>Ensure the grill control is set to Auto Product Recognition mode.</p>

## LIMITED WARRANTY ON EQUIPMENT

### TAYLOR COMPANY LIMITED WARRANTY ON C850 SERIES GRILL EQUIPMENT FOR MCDONALDS

Taylor Company is pleased to provide this limited warranty on new Taylor-branded C850 Series grill equipment available from Taylor (the Product) to the original McDonalds purchaser only.

#### LIMITED WARRANTY

Taylor warrants the Product against failure due to defect in materials or workmanship under normal use and service as follows. All warranty periods begin on the date of original Product installation. If a part fails due to defect during the applicable warranty period, Taylor, through an authorized Taylor distributor or service agency, will provide a new or remanufactured part, at Taylors option, to replace the failed defective part at no charge for the part.

Product	Part	Limited Warranty Period
Taylor C850 Series Grills	Parts not excluded below	Two (2) years

In addition, during the two (2) year period commencing on the date of original installation of the Product, Taylor will also provide, through an authorized Taylor distributor or service agency, all service needed to replace the failed defective part at no charge for the service. This no-charge service shall not be available for service performed by authorized McDonalds service technicians. Local sales and use taxes may still apply and will be charged accordingly.

Except as otherwise stated herein, these are Taylors exclusive obligations under this limited warranty for a Product failure. This limited warranty is subject to all provisions, conditions, limitations and exclusions listed below and on the reverse (if any) of this document.

#### LIMITED WARRANTY CONDITIONS

1. If the date of original installation of the Product cannot be verified, then the limited warranty period begins ninety (90) days from the date of Product manufacture (as indicated by the Product serial number). Proof of purchase may be required at time of service.
2. This limited warranty is valid only if the Product is installed and all required service work on the Product is performed by an authorized Taylor distributor or service agency, and only if genuine, new Taylor parts are used.
3. Installation, use, care, and maintenance must be normal and in accordance with all instructions contained in the Equipment Manual.
4. Defective parts must be returned to the authorized Taylor distributor or service agency for credit.

#### LIMITED WARRANTY EXCEPTIONS

This limited warranty does **not** cover:

1. Except as otherwise specifically set forth in this limited warranty, labor or other costs incurred for diagnosing, repairing, removing, installing, shipping, servicing or handling of defective parts, replacement parts, or new Products.
2. Normal maintenance and cleaning as outlined in the Equipment Manual, including cleaning of carbon and grease buildup.
3. Required service, whether cleaning or general repairs, to return the Products cooking surface assemblies, including the upper platen and lower plate, to an operational condition to achieve proper cooking or allow proper assembly of release sheets and clips as a result of grease build-up on the cooking surfaces, including but not limited to the platen and plate, sides of the shroud or top of the shroud.
4. Replacement of the Products cooking surfaces, including the upper platen and lower plate, due to pitting or corrosion (or in the case of the upper platen, due to loss of plating) as a result of damage due to the impact of spatulas or other small wares used during the cooking process or as a result of the use of cleaners, cleaning

materials or cleaning processes not approved for use by Taylor.

5. Replacement of wear items designated as Class 000 parts in the Equipment Manual, as well as any release sheets and clips.
6. External hoses, electrical power supplies, and machine grounding.
7. Parts not supplied or designated by Taylor, or damages resulting from their use.
8. Return trips or waiting time required because a service technician is prevented from beginning warranty service work promptly upon arrival.
9. Failure, damage or repairs due to faulty installation, misapplication, abuse, no or improper servicing, unauthorized alteration or improper operation or use as indicated in the Equipment Manual, including but not limited to the failure to use proper assembly and cleaning techniques, tools, or approved cleaning supplies .
10. Failure, damage or repairs due to theft, vandalism, wind, rain, flood, high water, water, lightning, earthquake or any other natural disaster, fire, corrosive environments, insect or rodent infestation, or other casualty, accident or condition beyond the reasonable control of Taylor; operation above or below the electrical or gas specification of the Product; or components repaired or altered in any way so as, in the judgment of the Manufacturer, to adversely affect performance, or normal wear or deterioration.
11. Any Product purchased over the Internet.
12. Failure to start due to voltage conditions, blown fuses, open circuit breakers, or damages due to the inadequacy or interruption of electrical service.
13. Electricity, gas or other fuel costs, or increases in electricity, gas or other fuel costs from any reason whatsoever.
14. **ANY SPECIAL, INDIRECT OR CONSEQUENTIAL PROPERTY OR COMMERCIAL DAMAGE OF ANY NATURE WHATSOEVER.** Some jurisdictions do not allow the exclusion of incidental or consequential damages, so this limitation may not apply to you.

This limited warranty gives you specific legal rights, and you may also have other rights which vary from jurisdiction to jurisdiction.

#### LIMITATION OF WARRANTY

**THIS LIMITED WARRANTY IS EXCLUSIVE AND IS IN LIEU OF ALL OTHER WARRANTIES, CONDITIONS AND/OR REMEDIES UNDER THE LAW, INCLUDING ANY IMPLIED WARRANTIES OR CONDITIONS OF MERCHANTABILITY OR FITNESS FOR A PARTICULAR PURPOSE. THE ORIGINAL OWNER'S SOLE REMEDY WITH RESPECT TO ANY PRODUCTS SHALL BE REPAIR OR REPLACEMENT OF DEFECTIVE COMPONENTS UNDER THE TERMS OF THIS LIMITED WARRANTY. ALL RIGHTS TO CONSEQUENTIAL OR INCIDENTAL DAMAGES (INCLUDING CLAIMS FOR LOST SALES, LOST PROFITS, PRODUCT LOSS, PROPERTY DAMAGES OR SERVICE EXPENSES) ARE EXPRESSLY EXCLUDED. THE EXPRESS WARRANTIES MADE IN THIS LIMITED WARRANTY MAY NOT BE ALTERED, ENLARGED, OR CHANGED BY ANY DISTRIBUTOR, DEALER, OR OTHER PERSON, WHATSOEVER.**

#### LEGAL REMEDIES

The owner **must** notify Taylor in writing, by certified or registered letter to the following address, of any defect or complaint with the Product, stating the defect or complaint and a specific request for repair, replacement, or other correction of the Product under warranty, mailed at least thirty (30) days before pursuing any legal rights or remedies.

Taylor Company  
750 N. Blackhawk Blvd.  
Rockton, IL 61072, USA

## LIMITED WARRANTY ON PARTS

### TAYLOR COMPANY LIMITED WARRANTY ON TAYLOR GENUINE PARTS

Taylor Company is pleased to provide this limited warranty on new Taylor genuine replacement components and parts available from Taylor to the market generally (the Parts) to the original purchaser only.

#### LIMITED WARRANTY

Taylor warrants the Parts against failure due to defect in materials or workmanship under normal use and service as follows. All warranty periods begin on the date of original installation of the Part in the Taylor unit. If a Part fails due to defect during the applicable warranty period, Taylor, through an authorized Taylor distributor or service agency, will provide a new or re-manufactured Part, at Taylors option, to replace the failed defective Part at no charge for the Part. Except as otherwise stated herein, these are Taylors exclusive obligations under this limited warranty for a Part failure. This limited warranty is subject to all provisions, conditions, limitations and exclusions listed below and on the reverse (if any) of this document.

Part's Warranty Class Code or Part	Limited Warranty Period
Class 103 Parts	Three (3) months
Class 212 Parts	Twelve (12) months
Class 512 Parts	Twelve (12) months
Class 000 Parts	No warranty

#### LIMITED WARRANTY CONDITIONS

1. If the date of original installation of the Part cannot be otherwise verified, proof of purchase may be required at time of service.
2. This limited warranty is valid only if the Part is installed and all required service work in connection with the Part is performed by an authorized Taylor distributor or service agency.
3. The limited warranty applies only to Parts remaining in use by their original owner at their original installation location in the unit of original installation.
4. Installation, use, care, and maintenance must be normal and in accordance with all instructions contained in the Taylor Operators Manual.
5. Defective Parts must be returned to the authorized Taylor distributor or service agency for credit.
6. This warranty is not intended to shorten the length of any warranty coverage provided pursuant to a separate Taylor Limited Warranty on freezer or grill equipment.
7. The use of any refrigerant other than that specified for the unit in which the Part is installed will void this limited warranty.

## LIMITED WARRANTY EXCEPTIONS

This limited warranty does **not** cover:

1. Labor or other costs incurred for diagnosing, repairing, removing, installing, shipping, servicing or handling of defective Parts, replacement Parts, or new Parts.
2. Normal maintenance, cleaning and lubrication as outlined in the Taylor Operators Manual, including cleaning of condensers or carbon and grease buildup.
3. Required service, whether cleaning or general repairs, to return the cooking surface assemblies, including the upper platen and lower plate, to an operational condition to achieve proper cooking or allow proper assembly of release sheets and clips as a result of grease build-up on the cooking surfaces, including but not limited to the platen and plate, sides of the shroud or top of the shroud.
4. Replacement of cooking surfaces, including the upper platen and lower plate, due to pitting or corrosion (or in the case of the upper platen, due to loss of plating) as a result of damage due to the impact of spatulas or other small wares used during the cooking process or as a result of the use of cleaners, cleaning materials or cleaning processes not approved for use by Taylor.
5. Replacement of wear items designated as Class 000 Parts in the Taylor Operators Manual, as well as any release sheets and clips for the Products upper platen assembly.
6. External hoses, electrical power supplies, and machine grounding.
7. Parts not supplied or designated by Taylor, or damages resulting from their use.
8. Return trips or waiting time required because a service technician is prevented from beginning warranty service work promptly upon arrival.
9. Failure, damage or repairs due to faulty installation, misapplication, abuse, no or improper servicing, unauthorized alteration or improper operation or use as indicated in the Taylor Operators Manual, including but not limited to the failure to use proper assembly and cleaning techniques, tools, or approved cleaning supplies.
10. Failure, damage or repairs due to theft, vandalism, wind, rain, flood, high water, water, lightning, earthquake or any other natural disaster, fire, corrosive environments, insect or rodent infestation, or other casualty, accident or condition beyond the reasonable control of Taylor; operation above or below the gas, electrical or water supply specification of the unit in which a part is installed; or Parts or the units in which they are installed repaired or altered in any way so as, in the judgment of Taylor, to adversely affect performance, or normal wear or deterioration.
11. Any Part purchased over the Internet.
12. Failure to start due to voltage conditions, blown fuses, open circuit breakers, or damages due to the inadequacy or interruption of electrical service.
13. Electricity, gas or other fuel costs, or increases in electricity or fuel costs from any reason whatsoever.
14. Damages resulting from the use of any refrigerant other than that specified for the unit in which the Part is installed will void this limited warranty.
15. Any cost to replace, refill or dispose of refrigerant, including the cost of refrigerant.
16. **ANY SPECIAL, INDIRECT, OR CONSEQUENTIAL PROPERTY OR COMMERCIAL DAMAGE OF ANY NATURE WHATSOEVER.** Some jurisdictions do not allow the exclusion of incidental or consequential damages, so this limitation may not apply to you.

This limited warranty gives you specific legal rights, and you may also have other rights which vary from jurisdiction to jurisdiction.

#### **LIMITATION OF WARRANTY**

**THIS LIMITED WARRANTY IS EXCLUSIVE AND IS IN LIEU OF ALL OTHER WARRANTIES, CONDITIONS AND/OR REMEDIES UNDER THE LAW, INCLUDING ANY IMPLIED WARRANTIES OR CONDITIONS OF MERCHANTABILITY OR FITNESS FOR A PARTICULAR PURPOSE. THE ORIGINAL OWNER'S SOLE REMEDY WITH RESPECT TO ANY PRODUCTS SHALL BE REPAIR OR REPLACEMENT OF DEFECTIVE PARTS UNDER THE TERMS OF THIS LIMITED WARRANTY. ALL RIGHTS TO CONSEQUENTIAL OR INCIDENTAL DAMAGES (INCLUDING CLAIMS FOR LOST SALES, LOST PROFITS, PRODUCT LOSS, PROPERTY DAMAGES OR SERVICE EXPENSES) ARE EXPRESSLY EXCLUDED. THE EXPRESS WARRANTIES MADE IN THIS LIMITED WARRANTY MAY NOT BE ALTERED, ENLARGED, OR CHANGED BY ANY DISTRIBUTOR, DEALER, OR OTHER PERSON, WHATSOEVER.**

#### **LEGAL REMEDIES**

The owner **must** notify Taylor in writing, by certified or registered letter to the following address, of any defect or complaint with the Part, stating the defect or complaint and a specific request for repair, replacement, or other correction of the Part under warranty, mailed at least thirty (30) days before pursuing any legal rights or remedies.

Taylor Company  
750 N. Blackhawk Blvd.  
Rockton, IL 61072, USA

## ORDERING/SERVICE INFORMATION

Taylor Distributor: \_\_\_\_\_

Address: \_\_\_\_\_

Telephone: \_\_\_\_\_

Date of Installation: \_\_\_\_\_

### Data Label

The data label provides necessary information that the operator should record and refer to when calling for parts or service. The data label is located on the front panel.

Complete for quick reference when this information is requested.

1. Model Number: \_\_\_\_\_

2. Serial Number: \_\_\_\_\_

3. Electrical Specs: \_\_\_\_\_

Voltage \_\_\_\_\_ Cycle \_\_\_\_\_ Phase \_\_\_\_\_

4. Maximum Fuse Size: \_\_\_\_\_ Amps

### Parts Warranty

See "Limited Warranty on Parts" on page 82.

**Note:** *Constant research results in steady improvements; therefore, information in this manual is subject to change without notice.*

### Release Sheets

Please refer to the following part numbers when ordering release sheets:

#### Upper platen release material

Taconic: DC WRIN#02701-015

#### Lower release material

Taconic: DC WRIN#02199-012



084949-M