

OPERATOR'S MANUAL



Model 432 Frozen Beverage Unit with Raised Drip Tray

Original Operating Instructions

066484-M

May, 2008 (Original Publication)
(Updated 6/27/2018)

Section 1: To the Installer

Installer Safety	1-1
Site Preparation	1-1
Air-Cooled Units	1-1
Electrical Connections	1-1
Beater Rotation	1-2
Refrigerant	1-3

Section 2: To the Operator

Compressor Warranty Disclaimer	2-1
--	-----

Section 3: Safety

Section 4: Operator Parts Identification

Model 432	4-1
Model 432 Parts Identification	4-2
Beater Door Assembly	4-3
Beater Door Assembly Parts Identification	4-4
Accessories	4-5

Section 5: User Interface

Control Switch (Item 1)	5-1
Push-Button Switch (Item 2)	5-1
Display Light Switch (Item 3)	5-1
Indicator Light—MIX OUT (Item 4)	5-2
Indicator Light—ADD MIX (Item 5)	5-2
Viscosity Adjustment (Item 6)	5-2

Section 6: Operating Procedures

Assembly	6-1
Sanitizing	6-5
Priming	6-6
Closing Procedure	6-7
Draining Product from the Freezing Cylinder	6-7
Rinsing	6-8
Cleaning	6-8
Disassembly	6-8
Brush Cleaning	6-8

Section 7: Operator Checklist

During Cleaning and Sanitizing7-1

Troubleshooting Bacterial Count7-1

Regular Maintenance Checks7-1

Winter Storage7-2

Section 8: Troubleshooting Guide

Section 9: Parts Replacement Schedule

Section 10: Limited Warranty on Equipment

Section 11: Limited Warranty on Parts

The following information has been included in the manual as safety and regulatory guidelines. For complete installation instructions, please see the Installation Checklist.

Installer Safety



IMPORTANT! In all areas of the world, equipment should be installed in accordance with existing local codes. Please contact your local authorities if you have any questions.

Care should be taken to ensure that all basic safety practices are followed during the installation and servicing activities related to the installation and service of Taylor® equipment.

- Only authorized Taylor service personnel should perform installation, maintenance, and repairs on Taylor equipment.
- Authorized service personnel should consult OSHA Standard 29CFR1910.147 or the applicable code of the local area for the industry standards on lockout/tagout procedures before beginning any installation or repairs.
- Authorized service personnel must ensure that the proper personal protective equipment (PPE) is available and worn when required during installation and service.
- Authorized service personnel must remove all metal jewelry, rings, and watches before working on electrical equipment.



DANGER! The main power supply(s) to the unit must be disconnected prior to performing any installation, maintenance, or repairs. Failure to follow this instruction may result in personal injury or death from electrical shock or hazardous moving parts as well as poor performance or damage to the unit.



WARNING! This unit has many sharp edges

that can cause severe injuries.

Site Preparation

Review the area where the unit will be installed. Make sure that all possible hazards to the installer, user, and the unit have been addressed.

For Indoor Use Only: This unit is designed to operate indoors, under normal ambient temperatures of 70°F to 75°F (21°C to 24°C). The unit has successfully performed in high ambient temperatures of up to 104°F (40°C) at reduced capacities.



WARNING! This unit must **NOT** be installed in an area where a water jet or hose can be used. **NEVER** use a water jet or hose to rinse or clean the unit. Failure to follow this instruction may result in electrocution.



CAUTION! This unit must be placed on a level surface. Extreme care should be taken when moving the unit for any reason. Two or more persons are required to safely move this unit. Failure to comply may result in personal injury or damage to the unit.

The authorized installer should inspect the unit for damage and promptly report any damage to the local authorized Taylor distributor.

This unit is made using USA sizes of hardware. All metric conversions are approximate and vary in size.

Air-Cooled Units

Do not obstruct air intake and discharge openings:

A minimum of 6 in. (152 mm) on both sides and 0 in. on the back is required. Failure to follow this instruction may cause poor freezer performance and damage to the machine.

Electrical Connections

This unit must be plugged into a properly grounded receptacle. The cord and plug must be sized for 20 A usage. The voltage specifications are 208-230/60/1.

TO THE INSTALLER

Follow specifications listed on your data plate.



1 In the United States, this equipment is intended to be installed in accordance with the National Electrical Code (NEC), ANSI/NFPA 70-1987. The purpose of the NEC code is the practical safeguarding of persons and property from hazards arising from the use of electricity. This code contains provisions considered necessary for safety. Compliance therewith and proper maintenance will result in an installation essentially free from hazard.

In all other areas of the world, equipment should be installed in accordance with the existing local codes. Please contact your local authorities.

Each unit requires one power supply for each data label on the unit. Check the data label(s) on the freezer for branch circuit overcurrent protection or fuse, circuit ampacity, and other electrical specifications. Refer to the wiring diagram provided inside the electrical box for proper power connections.



WARNING! This equipment must be properly grounded. Failure to do so can result in severe personal injury from electrical shock.



IMPORTANT! An equipotential grounding lug is provided with this unit. Some countries require the grounding lug be properly attached to the rear of the frame by the authorized installer. The installation location is marked by the equipotential bonding symbol (5021 of IEC 60417-1) on both the removable panel and the unit's frame.



IMPORTANT!

- Stationary appliances which are not equipped with a power cord and a plug or another device to disconnect the appliance from the power source must have an all-pole disconnecting device with a contact gap of at least 0.125 in. (3 mm) installed in the external installation.

- Appliances that are permanently connected to fixed wiring and for which leakage currents may exceed 10 mA, particularly when disconnected or not used for long periods, or during initial installation, shall have protective devices, to protect against the leakage of current such as a GFI, installed by the authorized personnel to the local codes.
- Supply cords used with this unit shall be oil-resistant, sheathed flexible cable not lighter than ordinary polychloroprene or other equivalent synthetic elastomer-sheathed cord (code designation 60245 IEC 57) installed with the proper cord anchorage to relieve conductors from strain, including twisting, at the terminals and protect the insulation of the conductors from abrasion.
- If the supply cord is damaged, it must be replaced by an authorized Taylor service technician in order to avoid a hazard.

Beater Rotation



NOTICE! Beater rotation must be clockwise as viewed looking into the freezing cylinder.

Note: The following procedures must be performed by an authorized Taylor service technician.

To correct rotation on a single-phase unit, change the leads inside the beater motor. (Follow the diagram printed on the motor.)

Refrigerant



CAUTION! In consideration of our environment, Taylor uses only earth-friendly HFC refrigerants. The HFC refrigerant used in this unit is R404A. This refrigerant is generally considered nontoxic and nonflammable with an ozone depleting potential (ODP) of zero (0). However, any gas under pressure is potentially hazardous and must be handled with caution.

Never fill any refrigerant cylinder completely with liquid. Filling the cylinder to approximately 80% will allow for normal expansion.



CAUTION! Use only R404A refrigerant that conforms to the AHRI standard 700 specification. The use of any other refrigerant may expose users and operators to unexpected safety hazards.



WARNING! Refrigerant liquid sprayed onto the skin may cause serious damage to tissue. Keep eyes and skin protected. If refrigerant burns should occur, flush immediately with cold water. If burns are severe, apply ice packs and contact a physician immediately.



NOTICE! Taylor reminds technicians to be aware of and in compliance with local government laws regarding refrigerant recovery, recycling, and reclaiming systems. For information regarding applicable local laws, please contact your local authorized Taylor distributor.



IMPORTANT! R404A refrigerant used in conjunction with polyolester oils are extremely moisture absorbent. When opening a refrigeration system, the maximum time the system is open must not exceed 15 minutes. Cap all open tubing to prevent humid air or water from being absorbed by the oil.

The freezer you have purchased has been carefully engineered and manufactured to give you dependable operation. The Taylor Model 432, when properly operated and cared for, will produce a consistent quality product. Like all mechanical products, it will require cleaning and maintenance. A minimum amount of care and attention is necessary if the operating procedures outlined in this manual are followed closely.

This Operator's Manual should be read before operating or performing any maintenance on your equipment.

Your Taylor freezer will **not** eventually compensate for and correct any errors during the setup or filling operations. Thus, the initial assembly and priming procedures are of extreme importance. It is strongly recommended that personnel responsible for the equipment's operation, both assembly and disassembly, sit down together and go through these procedures in order to be properly trained and to make sure that no misunderstandings exist.

In the event you should require technical assistance, please contact your local authorized Taylor distributor.

Note: *Your Taylor warranty is valid only if the parts are authorized Taylor parts, purchased from the local authorized Taylor distributor, and only if all required service work is provided by an authorized Taylor service technician. Taylor reserves the right to deny warranty claims on units or parts if unapproved parts or incorrect refrigerant were installed in the unit, system modifications were performed beyond factory recommendations, or it is determined that the failure was caused by abuse, misuse, neglect, or failure to follow all operating instructions. For full details of your Taylor warranty, please see the Limited Warranty section in this manual.*

Note: *Constant research results in steady improvements; therefore, information in this manual is subject to change without notice.*



IMPORTANT! *If the crossed-out, wheeled-bin symbol is affixed to this unit, it signifies that this unit is compliant with the EU Directives as well as other similar end-of-life legislation in effect after August 13, 2005. Therefore, it must be collected separately after its use is completed, and cannot be disposed as unsorted*

municipal waste.

The user is responsible for returning the unit to the appropriate collection facility, as specified by your local code.

For additional information regarding applicable local disposal laws, please contact the municipal waste facility and/or local authorized Taylor distributor.

Compressor Warranty Disclaimer

The refrigeration compressor(s) on this unit are warranted for the term stated in the Limited Warranty section in this manual. However, due to the Montreal Protocol and the U.S. Clean Air Act Amendments of 1990, many new refrigerants are being tested and developed, thus seeking their way into the service industry. Some of these new refrigerants are being advertised as drop-in replacements for numerous applications. It should be noted that in the event of ordinary service to this unit's refrigeration system, **only the refrigerant specified on the affixed data label should be used.** The unauthorized use of alternate refrigerants will void your Taylor compressor warranty. It is the unit owner's responsibility to make this fact known to any technician he employs.

It should also be noted that Taylor does not warrant the refrigerant used in its equipment. For example, if the refrigerant is lost during the course of ordinary service to this machine, Taylor has no obligation to either supply or provide its replacement either at billable or unbillable terms. Taylor does have the obligation to recommend a suitable replacement if the original refrigerant is banned, obsoleted, or no longer available during the five-year warranty of the compressor.

Taylor will continue to monitor the industry and test new alternates as they are being developed. Should a new alternate prove, through our testing, that it would be accepted as a drop-in replacement, then the above disclaimer would become null and void. To find out the current status of an alternate refrigerant as it relates to your compressor warranty, call the local Taylor distributor or the Taylor Factory. Be prepared to provide the model/serial number of the unit in question.

We, at Taylor Company, are concerned about the safety of the operator at all times when they are coming in contact with the unit and its parts. Taylor makes every effort to design and manufacture built-in safety features to protect both operators and service technicians.

Installing and servicing refrigeration equipment can be hazardous due to system pressure and electrical components. Only trained and qualified service personnel should install, repair, or service refrigeration equipment. When working on refrigeration equipment, observe precautions noted in the literature, tags and labels attached to the unit, and other safety precautions that may apply. Follow all safety code requirements. Wear safety glasses and work gloves.



DANGER! Failure to adhere to the following safety precautions may result in severe personal injury or death. Failure to comply with these warnings may also damage the unit and/or its components. Such damage may result in component replacement and service repair expenses.



NOTICE! DO NOT operate the unit without reading this entire manual first. Failure to follow all of these operating instructions may result in damage to the unit, poor performance, health hazards, or personal injury.



IMPORTANT! *This appliance is to be used only by trained personnel. It is not intended for use by children or people with reduced physical, sensory, or mental capabilities, or lack of experience and knowledge. Where limited equipment operation is allowed for public use, such as a self-serve application, supervision or instruction concerning the use of the appliance by a person responsible for their safety is required. Children should be supervised to ensure that they do not play with the appliance.*



WARNING! Avoid injury.

- **DO NOT** operate the unit unless it is properly grounded.
- **DO NOT** operate the unit with larger fuses than specified on the unit's data label.
- All repairs should be performed by an authorized Taylor service technician.
- Cord Connected Units: Only Taylor authorized service technicians may install a plug on this unit.
- The main power supplies to the unit must be disconnected prior to performing installation, repairs, or maintenance.
- Units that are permanently connected to fixed wiring and for which leakage currents may exceed 10 mA, particularly when disconnected or not used for long periods, or during initial installation, shall have protective devices to protect against the leakage of current, such as a GFI, installed by the authorized personnel to the local codes.
- Stationary units which are not equipped with a power cord and a plug or another device to disconnect the appliance from the power source must have an all-pole disconnecting device with a contact gap of at least 0.125 in. (3 mm) installed in the external installation.
- Supply cords used with this unit shall be oil-resistant, sheathed flexible cable not lighter than ordinary polychloroprene or other equivalent synthetic elastomer-sheathed cord (code designation 60245 IEC 57) installed with the proper cord anchorage to relieve conductors from strain, including twisting, at the terminals and protect the insulation of the conductors from abrasion.
- If the supply cord is damaged, it must be replaced by an authorized Taylor service technician in order to avoid a hazard.

Failure to follow these instructions may result in

SAFETY

electrocution. Contact your local authorized Taylor distributor for service.



IMPORTANT! An equipotential grounding lug is provided with this unit. Some countries require the grounding lug be properly attached to the rear of the frame by the authorized installer. The installation location is marked by the equipotential bonding symbol (5021 of IEC 60417-1) on both the removable panel and the unit's frame.

3



WARNING! DO NOT use a water jet to clean or rinse the unit. Failure to follow these instructions may result in serious electrical shock.



WARNING! Avoid injury.

- **DO NOT** allow untrained personnel to operate this unit.
- **DO NOT** operate the unit unless all service panels and access doors are restrained with screws.
- **DO NOT** remove any internal operating parts (including, but not limited to, freezer door, beater, or scraper blades), unless all control switches are in the OFF position.

Failure to follow these instructions may result in severe personal injury, especially to fingers or hands, from hazardous moving parts.



WARNING! This unit has many sharp edges that can cause severe injuries.

- **DO NOT** put objects or fingers in the door spout. This may contaminate the product and cause severe personal injury from blade contact.
- **USE EXTREME CAUTION** when removing the beater assembly. The scraper blades are very sharp.



CAUTION! This unit must be placed on a level surface. Extreme care should be taken when moving the unit for any reason. Two or more persons are required to safely move this unit. Failure to comply may result in personal injury or damage to the unit.



IMPORTANT! Access to the service area of the unit must be restricted to persons having knowledge and practical experience with the unit, in particular as far as safety and hygiene are concerned.



NOTICE! Cleaning and sanitizing schedules are governed by your federal, state, or local regulatory agencies and must be followed accordingly. Please refer to the cleaning section of this manual for the proper procedure to clean this unit.



CAUTION! This unit is equipped with a refrigerated cabinet, designed to maintain product temperature at or below 41°F (5°C). Any product being added to this machine must be below 41°F (5°C). Failure to follow this instruction may result in health hazards and poor freezer performance.

DO NOT run the unit without product. Failure to follow this instruction can result in damage to the unit.

DO NOT obstruct air intake and discharge openings: 6 in. (152 mm) minimum air space on front, sides and rear, and 0 in. (0 mm) on bottom.

For Indoor Use Only: This unit is designed to operate indoors, under normal ambient temperatures of 70°F to 75°F (21°C to 24°C). The unit has successfully performed in high ambient temperatures of up to 104°F (40°C) at reduced capacities.

Noise Level: Airborne noise emission does not exceed 78 dB(A) when measured at a distance of 39 in. (1.0 m) from the surface of the unit and at a height of 62 in. (1.6 m) from the floor.

Model 432

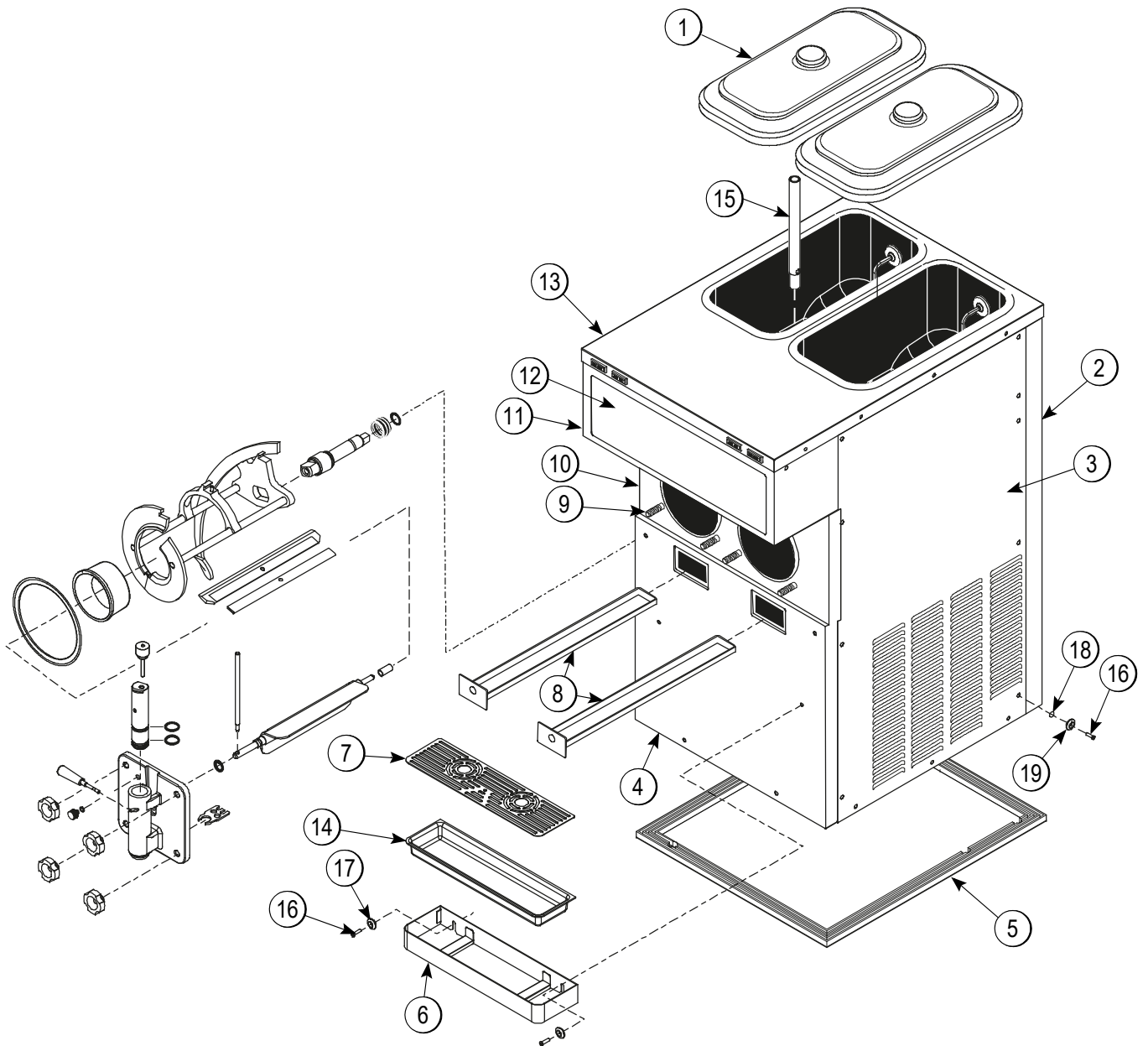

Figure 4-1

OPERATOR PARTS IDENTIFICATION

Model 432 Parts Identification

Item	Description	Part No.
1	Cover A.-Hopper	X52452
2	Panel-Rear	052363
3	Panel-Side Right	066452
4	Panel-Front Lower	066405
5	Gasket-Base Pan	052377
6	Shelf A.- Drip Tray	X66421
7	Shield- Splash	066419
8	Pan- Drip 17- 1/2 LG	027504-GRY
9	Stud- Nose Cone	013496
10	Panel A.- Upper Front	X66410
11	Light A.- LED *432*	080966- 05

Item	Description	Part No.
12	Lens- Decorative Plate	052359
13	Panel- Side- Left	066453
14	Tray- Drip	066420
15	Tube- Feed W/DBL 3/8 Hole	015176-SP9
16	Screw- 10- 32X3/4 SLTD	001086
17	Collar- Holding	019481
18	O- Ring- SQ- .358ID X .139W	066456
19	Collar- Holding- .730DIA X .184	066457
*20	Screw- 10X7/16 UNSL TD HWH- Base Pan Gasket	066234

*Not Shown

Beater Door Assembly

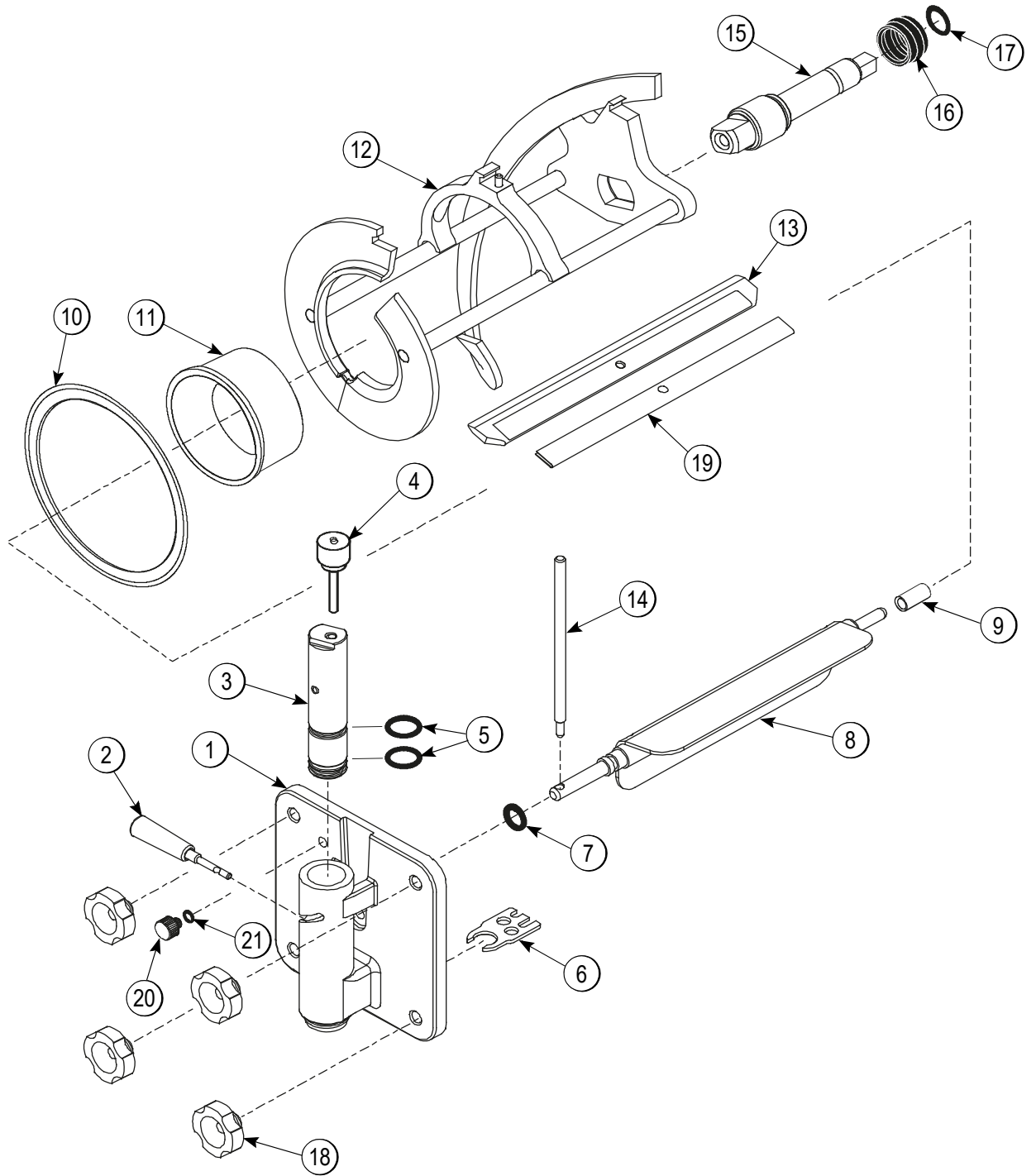

4

Figure 4-2

Beater Door Assembly Parts Identification

Item	Description	Part No.
1	Door A.-Slush-Partial	X83427SER2
2	Handle A.-Draw-Slush	X47384
3	Valve Draw - Slush	047734
4	Pin A.- Valve Handle	X25929
5	O-Ring- 1"OD X.139W	032504
6	Buster - Ice	047735
7	O-Ring -.291 OD X.080 W	018550
8	Torque A. *432*	X66393
9	Bearing - Guide	014496
10	Gasket- Door 5.109 X 5.630	014030
11	Bearing - Front	013116

Item	Description	Part No.
12	Beater A. - 4 QT. 1 Pin	X49490
13	Blade- Scraper- Plastic	046237
14	Arm- Torque *432* SOFT	052450-SP
15	Shaft - Beater	035418
16	Seal - Drive Shaft	032560
17	O-Ring 7/8 OD X.139 W	025307
18	Nut- Stud	029880
19	Clip- Scraper Blade 8.75"	046238
20	Plug- Prime*430*STNLS	050405
21	O-Ring-.563 OD X.070W	043758

4

Accessories

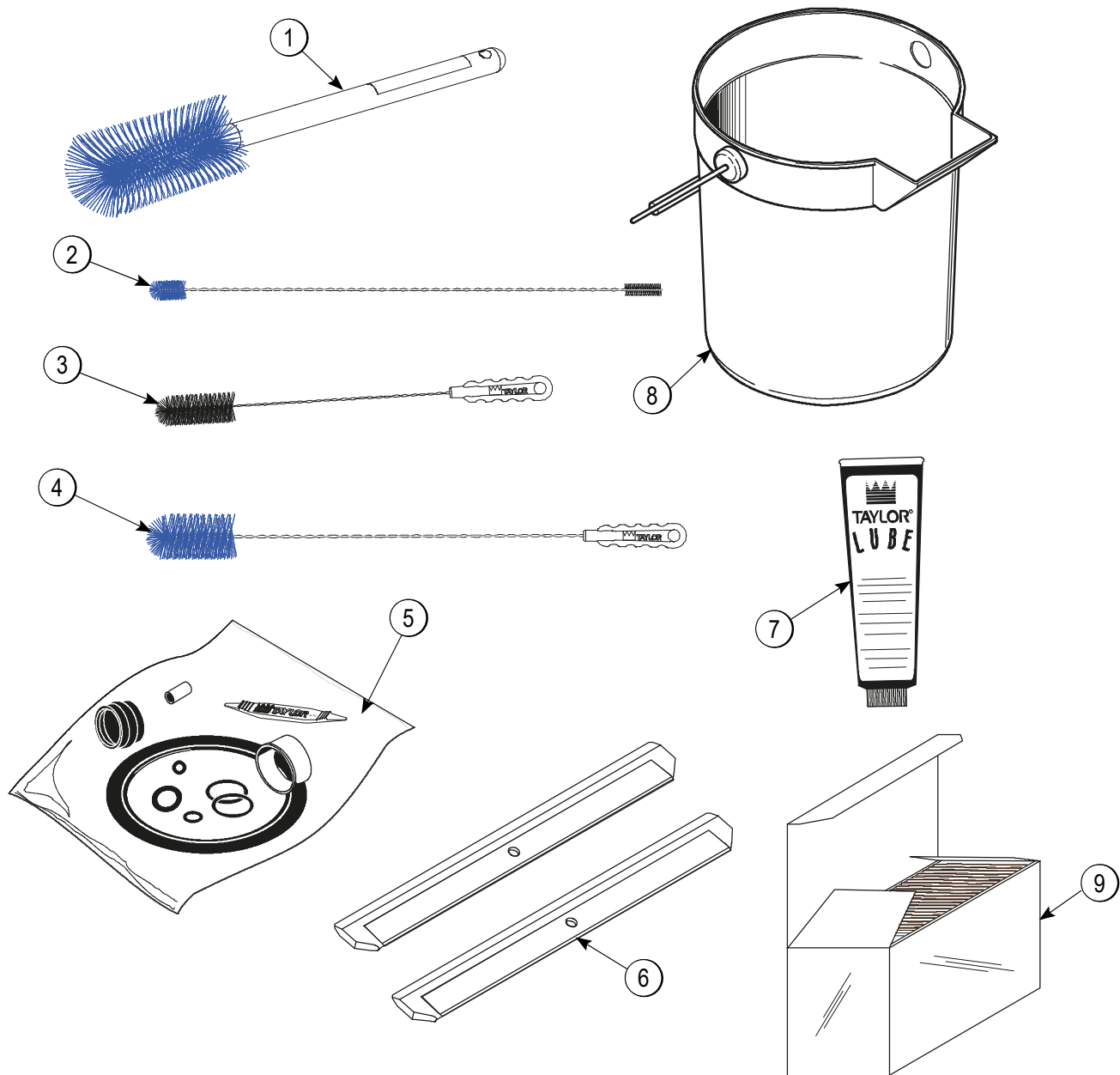

Figure 4-3

Item	Description	Part No.
1	Brush- Mix Pump Body- 3X7	023316
2	Brush- Double Ended	013072
3	Brush- Rear BRG 1"D X 2" LG X 14"	013071
4	Brush- Draw Valve 1- 1/2"OD X 3"	014753

Item	Description	Part No.
5	Kit A.- Tune Up	X50413
6	Blade- Scraper- Plastic	046237
7	Lubricant- Taylor	047518
8	Pail- 10 QT.	013163
*9	Sanitizer- Stera Sheen	055492

***Note:** A sample container of sanitizer is sent with the unit. For reorders, order Stera Sheen part no. 055492 (100 packs) or Kay- 5 part no. 041082 (125 packs).

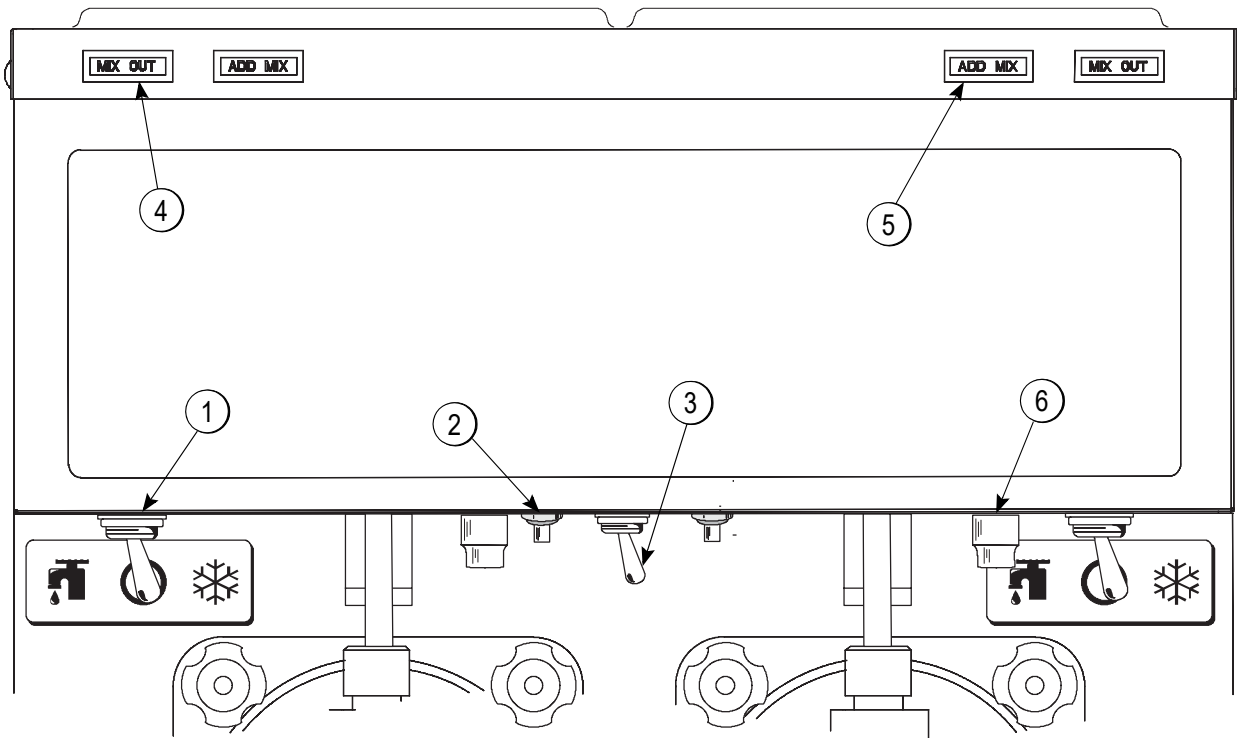





Figure 5-1

Item	Description
1	Switch- Toggle - 3 PDT
2	Switch- Push Button - SPST
3	Switch- Toggle- SPST - 3/4 HP/250 V
4	Light- Amber- Rect. - 12 VDC - MIX OUT
5	Light- Amber- Rect. - 12 VDC - ADD MIX
6	Viscosity Adjustment

The following chart identifies the symbol definitions used on the operator switches.

 = ON/AUTO

 = OFF

 = WASH

Control Switch (Item 1)

The center position is OFF. The left position is WASH, which activates only the beater motor. The right position is AUTO, which activates the beater motor and the refrigeration system.

Push-Button Switch (Item 2)

If an overload condition occurs, the freezer will automatically stop operating. To properly reset the freezer, place the toggle switch in the OFF position. Wait two or three minutes, then press the push-button switch. Place the power switch in the WASH position and observe the freezer's performance. Place the power switch in the AUTO position.

Note: If the freezer is unplugged from the wall receptacle, it will be necessary to press the push-button switch for the freezer to operate once power is re-established.

Display Light Switch (Item 3)

The display light switch is located under the control channel. The left position is OFF. The right position is ON and activates the display light.

Indicator Light—MIX OUT (Item 4)

A MIX OUT indicating light is located on the front of the machine. When the light is flashing, the hopper is empty and the mix supply needs replenishing. To prevent damage to the unit, refrigeration discontinues automatically when the MIX OUT indicator light illuminates. Refrigeration will restart 30 seconds after the mix supply is replenished.

Indicator Light—ADD MIX (Item 5)

A MIX LEVEL indicating light is located on the front of the machine. When the light is flashing, the mix hopper has a low supply of product and should be refilled as soon as possible.

Viscosity Adjustment (Item 6)

The viscosity (thickness) of the slush can be adjusted by turning the viscosity adjustment screw located under the control channel. Turn the viscosity adjustment screw clockwise for a thicker product or counterclockwise for a thinner product. After making an adjustment, allow the refrigeration system to cycle two or three times to accurately evaluate the viscosity.

The Model 432 freezer is designed to produce shake or slush product at the desired thickness. This unit has two 4 qt. freezing cylinders.

We begin our instructions at the point where we enter the store in the morning and find the parts disassembled and laid out to air dry from the previous night's brush cleaning.

These opening procedures will show you how to assemble these parts into the freezer, sanitize them, and prime the freezer with fresh mix in preparation to serve your first portion.

If you are disassembling the machine for the first time or need information to get to this point in our instructions, turn to page 6-8 "Disassembly," and start there.

Assembly

Note: When lubricating parts, use an approved food grade lubricant (example: Taylor Lube).

1. Lubricate the groove on the drive shaft and slide the O-ring in place. Lubricate the O-ring and shaft portion that comes in contact with the bearing. **Do not lubricate the square end of the drive shaft.** Lubricate the boot seal groove and slide the boot seal over the shaft and groove until it snaps into place. Fill the inside portion of the seal with 1/4 in. more lubricant and evenly lubricate the end of the seal that fits onto the rear shell bearing.

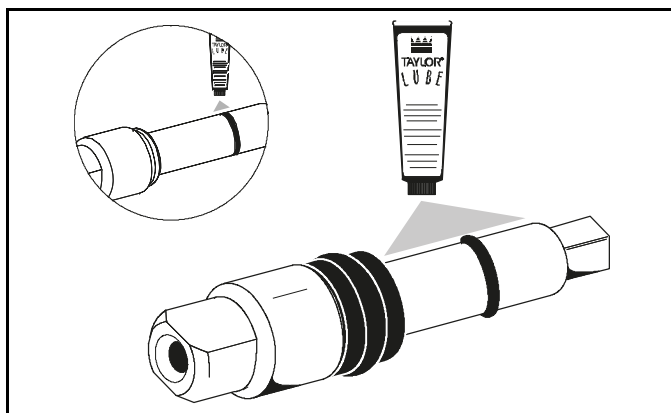

Figure 6-1

Note: To ensure that the mix does not leak out of the back of the freezing cylinder, the middle section of the boot seal should be convex or extend from the seal. If the middle section of the boot seal is concave or extending into the middle of the seal, invert the seal.

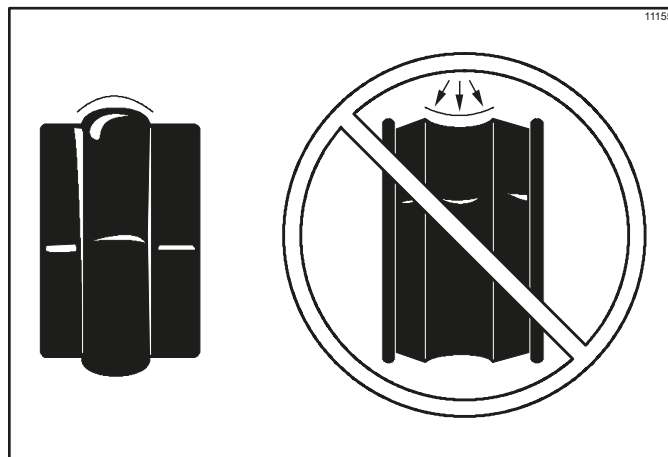

Figure 6-2

2. Insert the beater drive shaft into the rear shell bearing and engage the square end firmly into the female socket of the drive unit. Make sure the drive shaft fits into the drive coupling without binding.

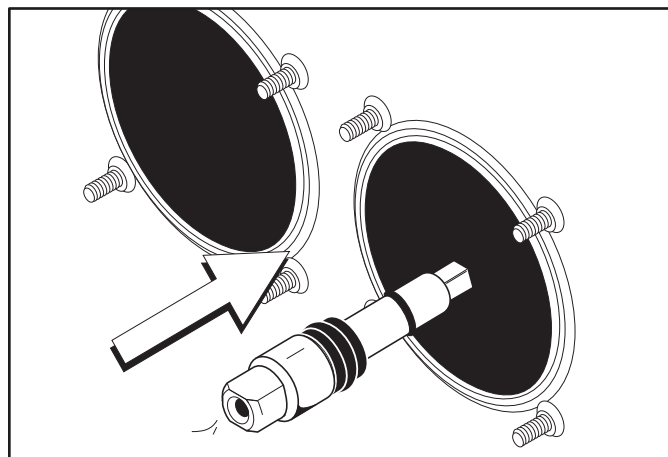

Figure 6-3



WARNING! Use extreme caution when handling the beater assembly. The scraper blades are very sharp and may cause injury.

3. Before installing the beater assembly, inspect the scraper blades and clips.

Check the scraper blades for any signs of wear or damage. If a scraper blade is nicked or worn, replace both blades.

Check the scraper blade clips to make sure they are not bent and the slot is even for the entire length of

the clip. Replace any damaged clips.

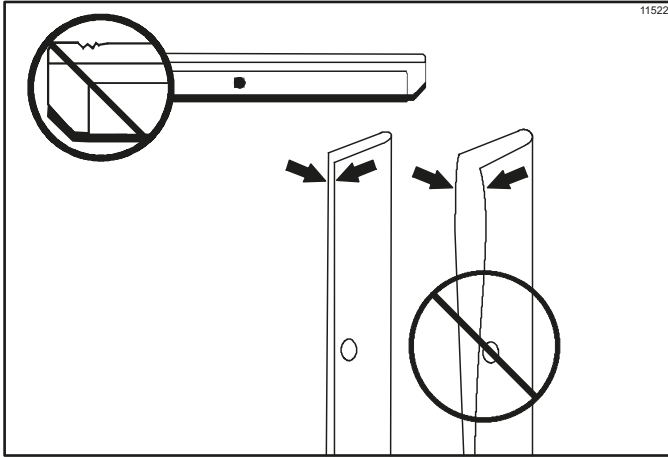

Figure 6-4

4. If the blades and clips are in good condition, place the clip over the blade and install the blade and clip on the beater assembly. Make sure the holes in the blade and the clip are securely positioned over the beater pin.

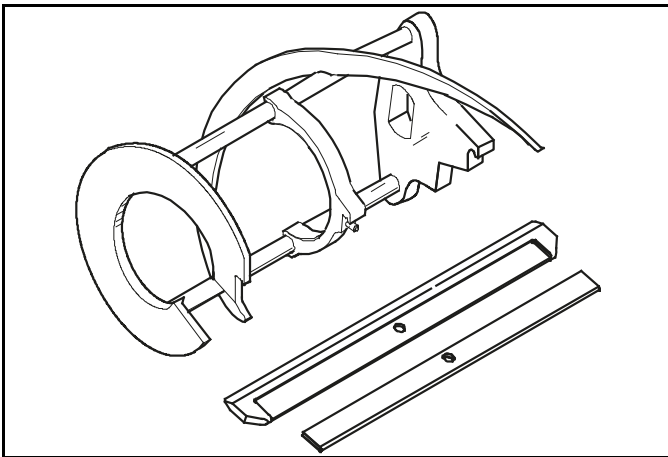

Figure 6-5

5. Holding the beater securely, slide the beater into the freezing cylinder and align the hole at the rear of the beater with the flats on the end of the drive shaft. Slide the beater the remainder of the way into the freezing cylinder and over the end of the drive shaft. The beater assembly will not protrude beyond the front of the freezing cylinder.

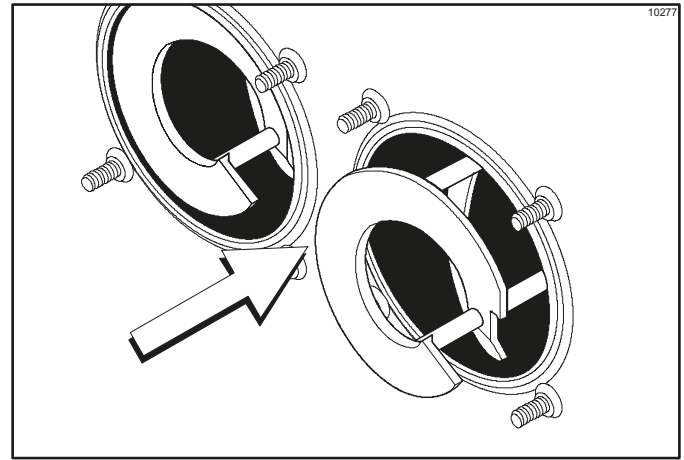

Figure 6-6

6. Install the white plastic guide bearing on the short end of the torque rotor. Slide the O-ring into the groove on the long end of the torque rotor and lubricate the O-ring. **Do not** lubricate the guide bearing.

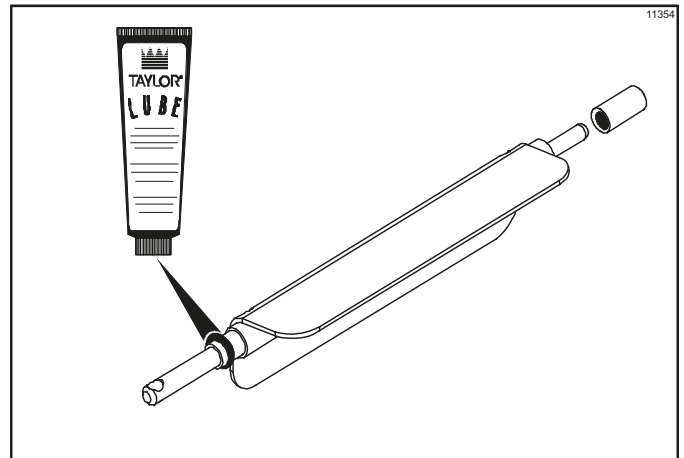

Figure 6-7

7. Insert the torque rotor end with the guide bearing into the pilot hole in the center of the drive shaft. The hole in the torque rotor shaft should be rotated to the twelve o'clock position.

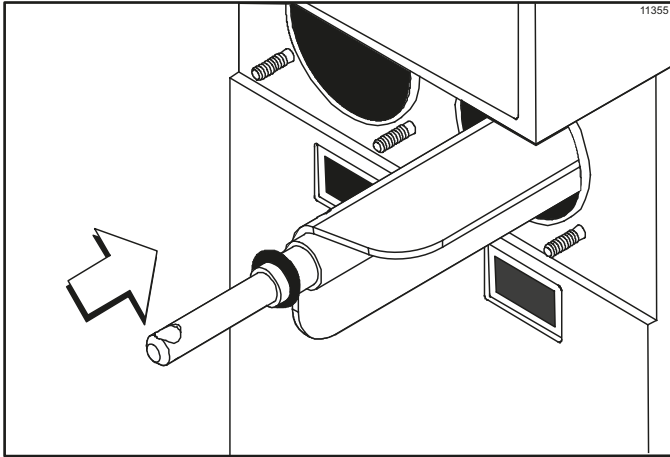

Figure 6-8

- 8. Before assembling the freezer door, check the following for any nicks, cracks, or signs of wear: front bearing, door gasket, draw valve, O-rings, and all sides of the door assembly, including the inside of the draw valve bore. Replace any damaged parts.
- 9. Install the O-rings on the draw valve and lubricate.

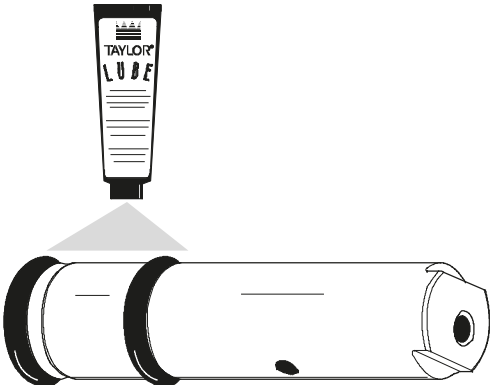

Figure 6-9

- 10. Insert the draw valve into the door, leaving approximately half of the valve sticking out the top of the door.

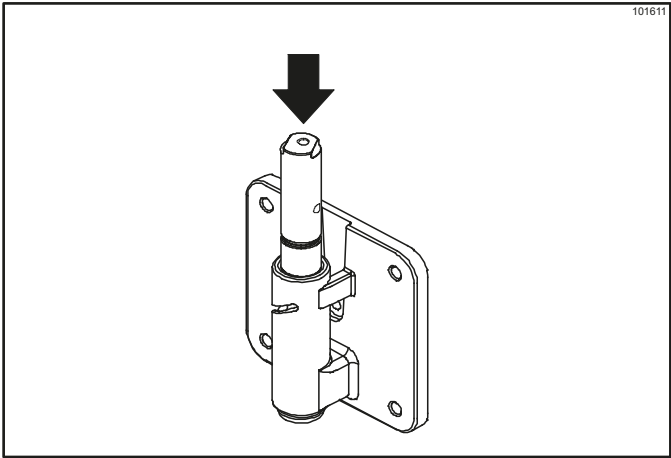

Figure 6-10

- 11. Rotate the draw valve so the flats on the top of the draw valve are perpendicular to the door face.

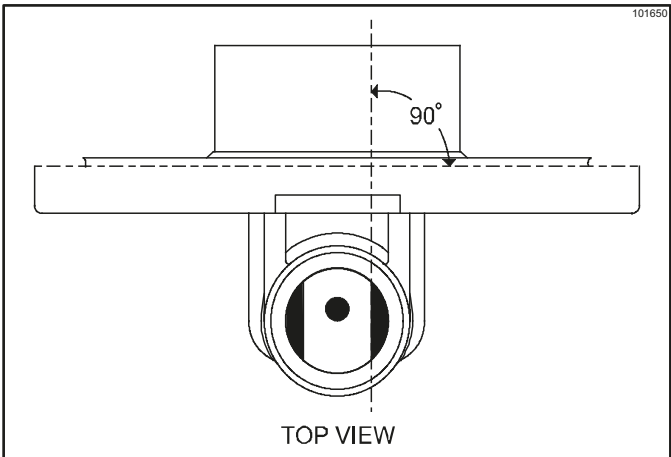

Figure 6-11

- 12. Insert the ice buster through the door spout and into the slot located just above the lower O-ring.

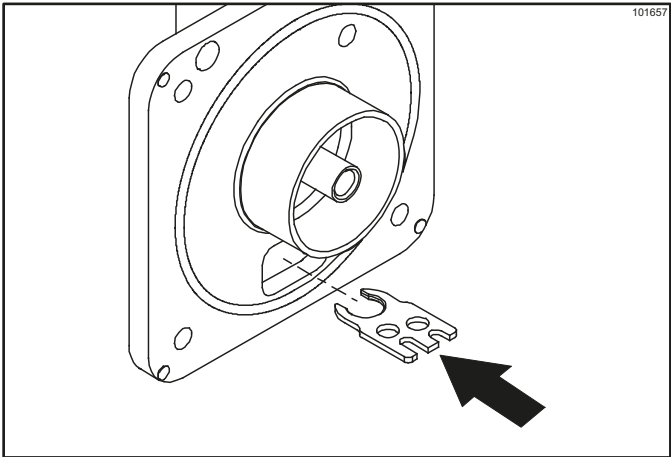

Figure 6-12

- 13. With the ice buster in place, rotate the draw valve to allow installation of the draw handle. This will lock the ice buster in place. Install the draw handle pin and

OPERATING PROCEDURES

close the draw valve by moving the handle to the left.

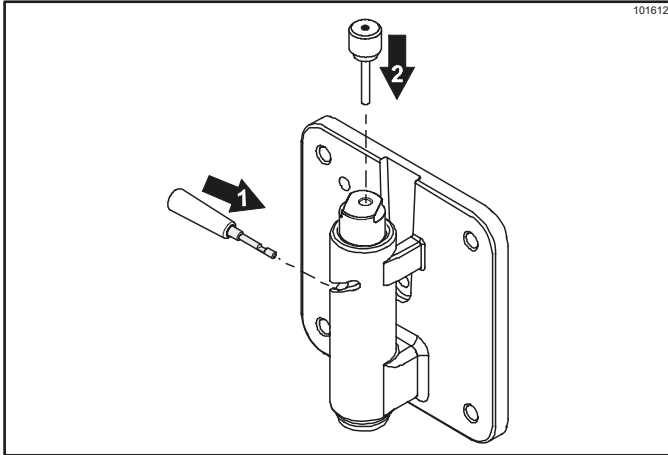

Figure 6-13

14. Place the O-ring onto the prime plug and lubricate.

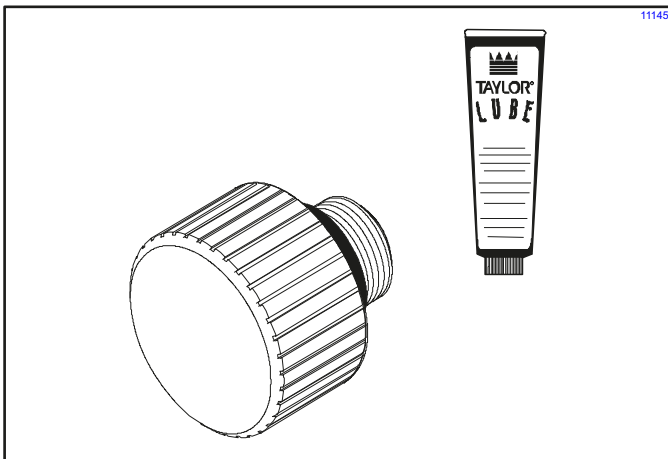

Figure 6-14

15. Screw the prime plug into position on the front of the door.

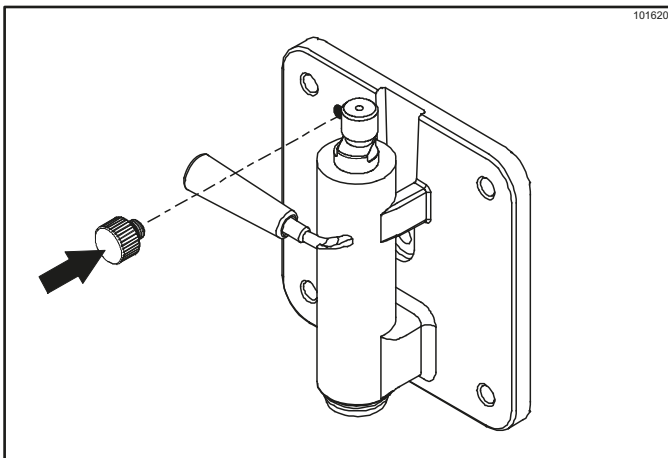

Figure 6-15

16. Place the large rubber gasket into the groove on the back side of the freezer door. Slide the white, plastic front bearing onto the bearing hub, making sure the

flanged end of the bearing is resting against the freezer door.

Do not lubricate the door gasket or front bearing.

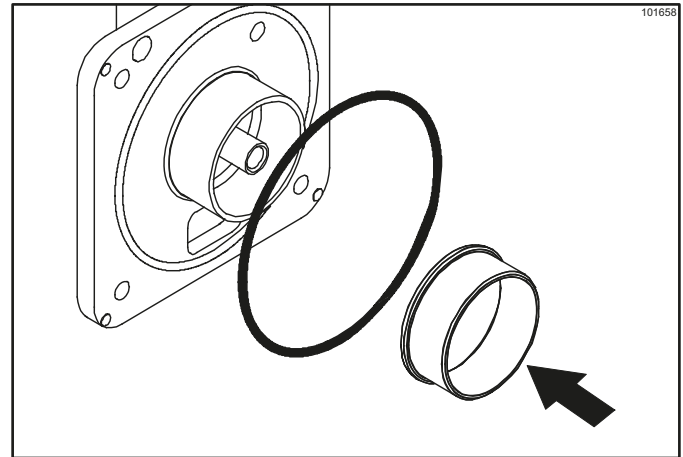

Figure 6-16

17. Install the door on the four studs on the front of the freezing cylinder. Install the four handscrews on the door and tighten them equally in a crisscross pattern.

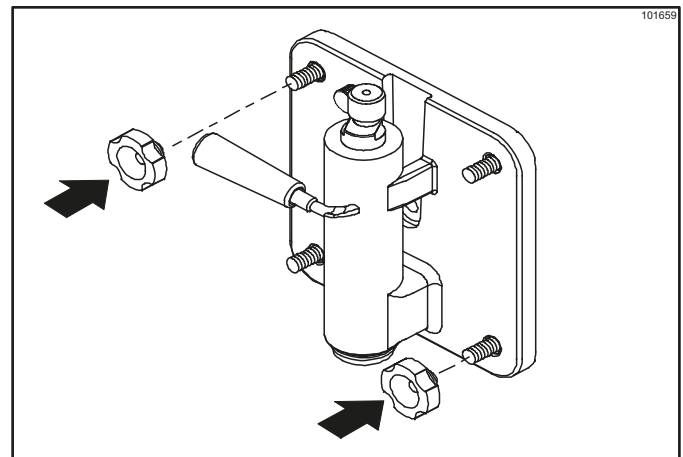

Figure 6-17

18. Position the torque arm by inserting it through the slot in the torque switch arm and down into the hole in the torque rotor, which protrudes from the door. Verify proper installation by moving the torque rotor back and forth to be sure it moves freely and easily.

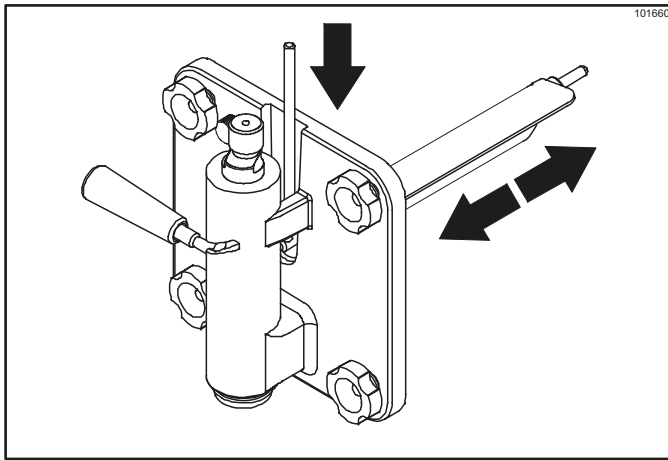

Figure 6-18

Important! Make sure the torque rotor is positioned with the large hole on the top. The torque arm must be inserted into the large hole and protrude through the other side.

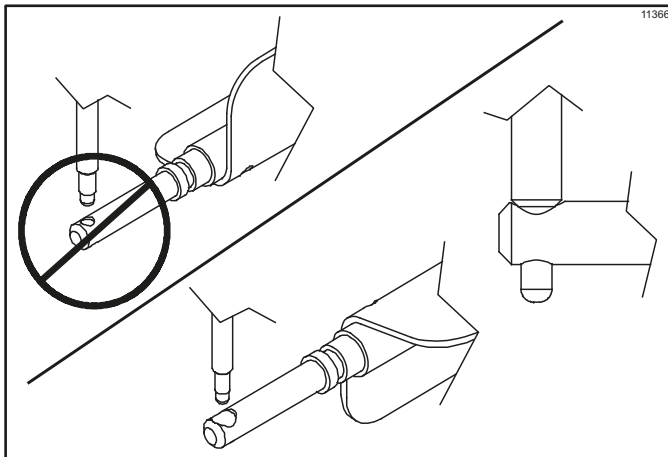

Figure 6-19

19. Install the long drip pans into the holes in the front panel.

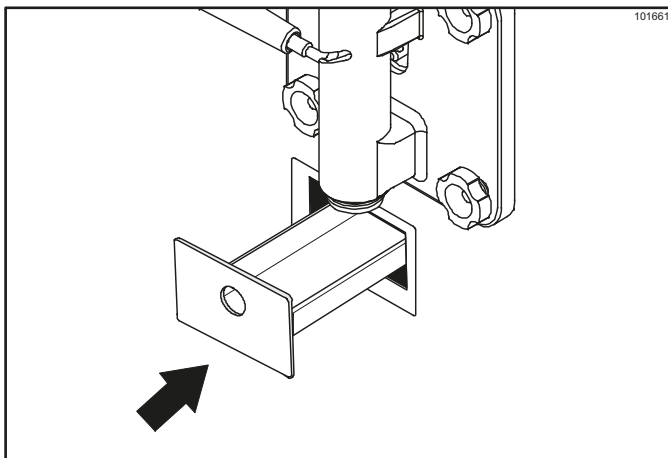

Figure 6-20

20. Repeat step 1 through step 19 for the other side of

the unit.

21. Install the front drip tray and splash shield beneath the door spouts.

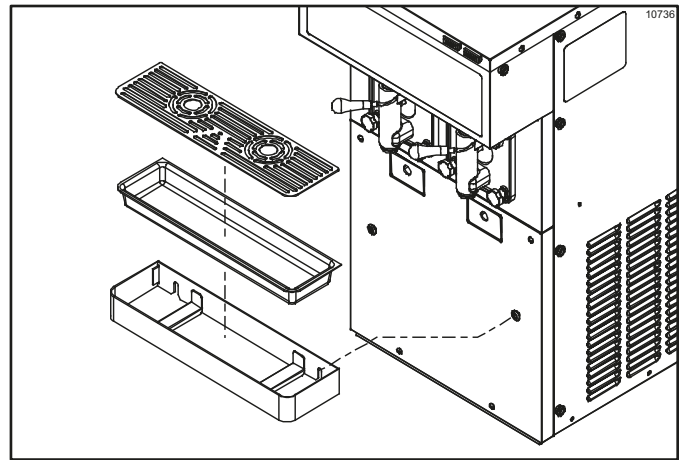

Figure 6-21

22. Lay the air/mix feed tube in the bottom of the mix hopper.

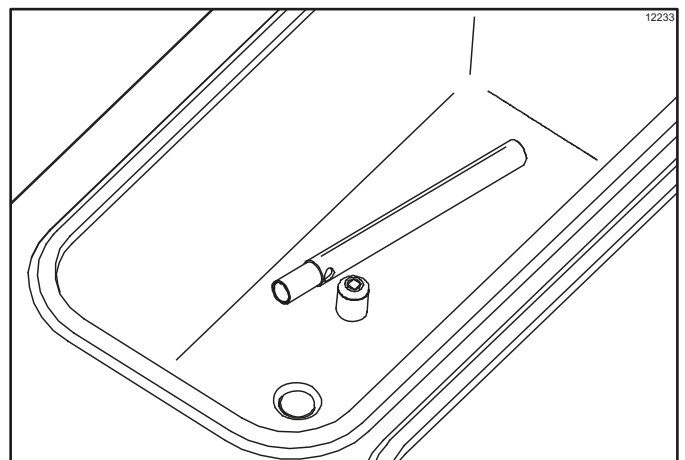

Figure 6-22

Sanitizing

1. Prepare an approved 100 PPM sanitizing solution (examples: 2-1/2 gal. [9.5 L] of Kay-5® or 2 gal. [7.6 L] of Stera-Sheen®). Use warm water and follow the manufacturer's specifications.
2. Pour the sanitizing solution into the hopper and allow it to flow into the freezing cylinder.

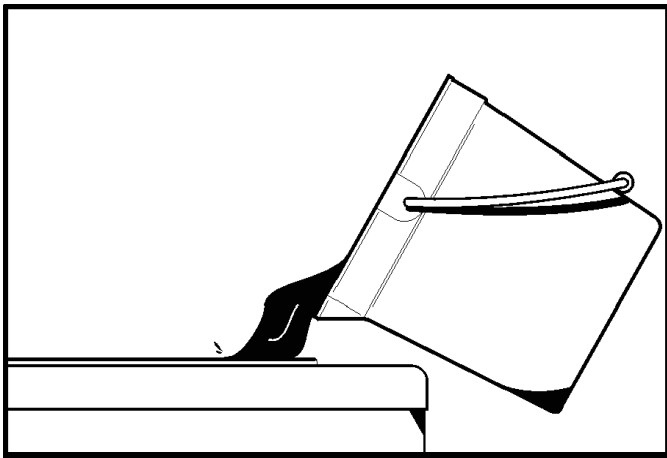

Figure 6-23

3. While the solution is flowing into the freezing cylinder, brush clean the mix hopper, air/mix feed tube (optional), and mix inlet hole.
4. Place the power switch in the WASH position. This will agitate the sanitizing solution in the freezing cylinder. Allow the solution to agitate for five minutes.

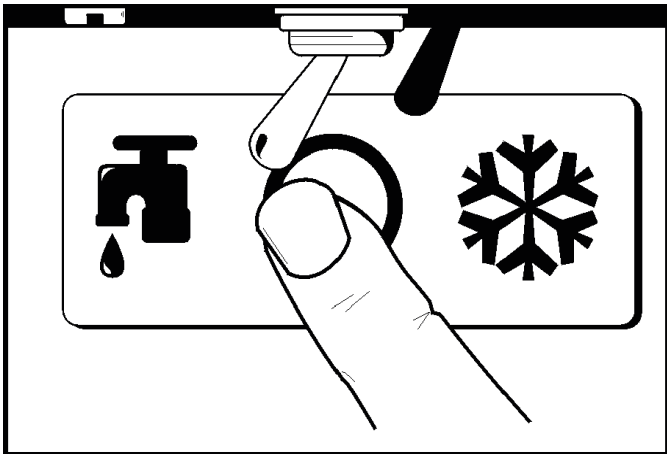

Figure 6-24

5. Place an empty pail beneath the door spout and move the draw handle to the right. Draw off all the sanitizing solution. When the sanitizer stops flowing from the door spout, move the draw handle to the left and place the control switch in the OFF position.

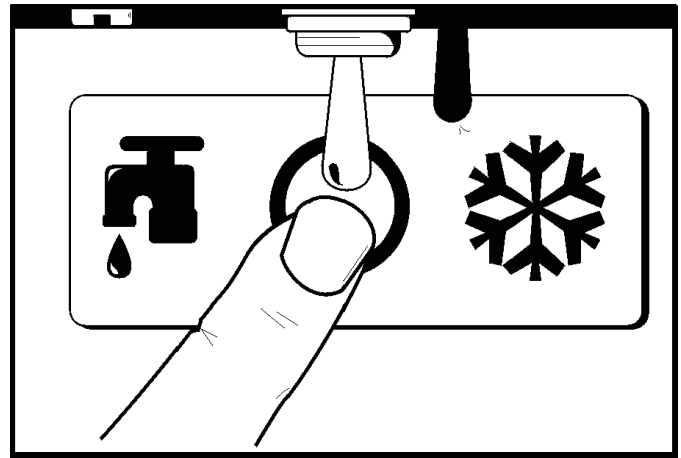

Figure 6-25

Important! The unit must Not be placed in AUTO until all sanitizing solution has been removed from the freezing cylinder and proper priming procedures have been completed. Failure to follow this instruction may result in damage to the freezing cylinder.

6. **With sanitized hands**, stand the air/mix feed tube in the corner of the hopper.

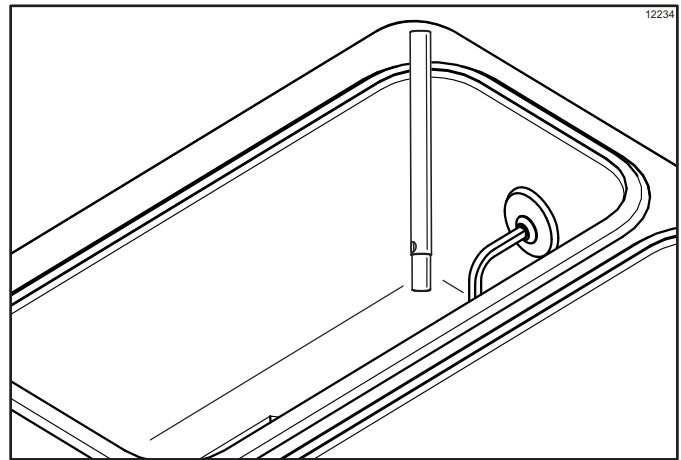

Figure 6-26

7. Repeat step 1 through step 6 for the other side of the unit.

Note: An air/mix feed tube should only be installed in one of the hoppers.

Priming

1. With a pail beneath the door spout, move the draw handle to the right. Pour 2 gal. (7.6 L) of **fresh** mix into the hopper and allow it to flow into the freezing cylinder. This will force out any remaining sanitizing solution. When full strength mix is flowing from the door spout, move the draw handle to the left.

Important! Failure to remove all sanitizing solution may result in damage to the freezing cylinder.

- Open the prime plug by turning it counterclockwise until the air in the freezing cylinder is allowed to escape. When product rises to the bleed port, close the prime plug by turning it clockwise until it is snug against the freezer door.
- When the mix has stopped bubbling down into the freezing cylinder, install the air/mix feed tube in the mix inlet hole with the hole side down.

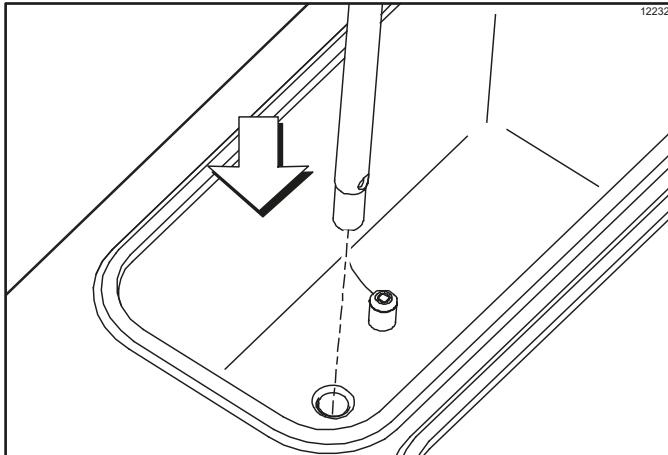

Figure 6-27

- Place the power switch in the AUTO position. When the unit cycles off, the product will be at serving viscosity. The viscosity (thickness) of the slush can be adjusted by turning the viscosity adjustment screw located under the control channel. Turn the viscosity adjustment screw clockwise for a thicker product or counterclockwise for a thinner product. After making an adjustment, allow the refrigeration system to cycle two or three times to accurately evaluate the viscosity.

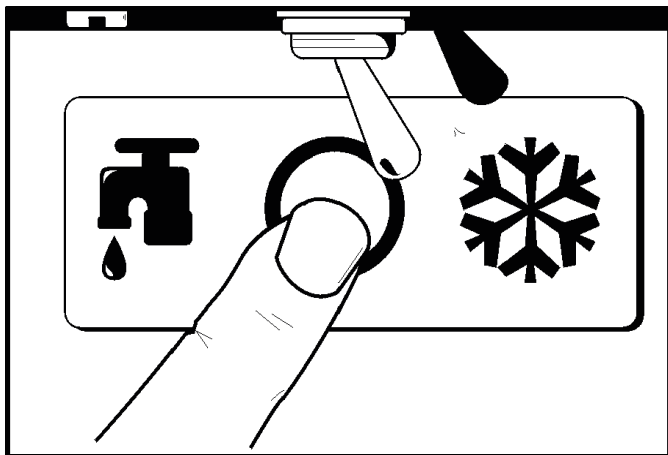

Figure 6-28

Note: To identify the viscosity adjustment screw, see Figure 5-1 on page 5-1.

- Place the mix hopper cover in position. Periodically during the day's operation, check to be sure there is a sufficient amount of mix in the hopper.

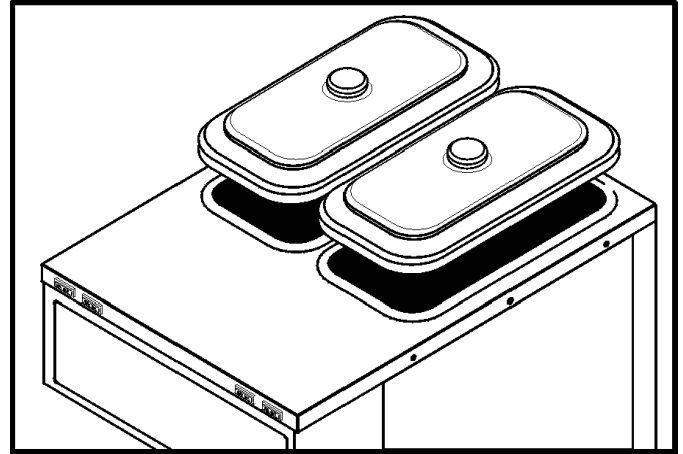

Figure 6-29

- Repeat step 1 through step 5 for the other side of the unit.

Note: An air/mix feed tube should only be installed in one of the hoppers.

Closing Procedure

To disassemble this unit, the following items will be needed:

- Two cleaning pails
- Necessary brushes (provided with freezer)
- Cleaner
- Single-service towels

Draining Product from the Freezing Cylinder

- Place the power switch in the OFF position as far ahead of cleaning time as possible to allow frozen product to soften for easier cleaning.
- Raise the hopper cover. Using sanitized hands, remove the air/mix feed tube and take it to the sink for cleaning.
- If local health codes permit the use of rerun**, place a sanitized, NSF-approved stainless steel rerun container beneath the door spout. Place the power switch in the WASH position and move the draw handle to the right. When all the product stops flowing from the door spout, move the draw handle to the left and place the power switch in the OFF

OPERATING PROCEDURES

position. Place the sanitized lid on the rerun container and place it in the walk-in cooler.

Note: If local health codes do not permit the use of rerun, the product must be discarded. Follow the instructions in the previous step, except drain the product into a pail and properly discard the mix.

- Repeat step 1 through step 3 for the other side of the unit.

Note: An air/mix feed tube should only be installed in one of the hoppers.



ALWAYS FOLLOW LOCAL HEALTH CODES.

Rinsing

- Pour 2 gal. (7.6 L) of cool, clean water into the mix hopper. With the brushes provided, scrub the mix hopper and the mix inlet hole.

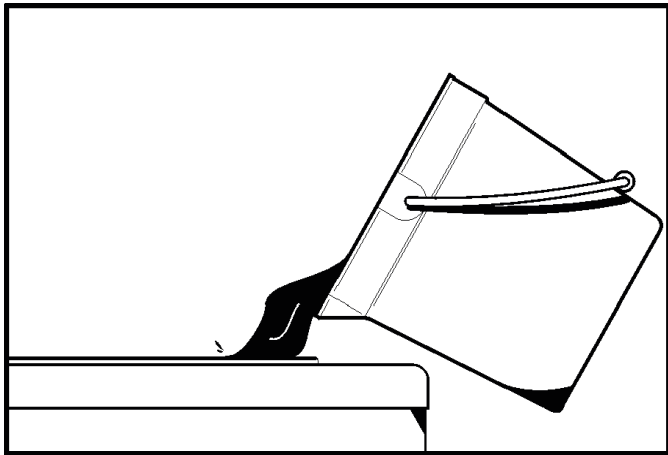

Figure 6-30

- With a pail beneath the door spout, place the power switch in the WASH position and move the draw handle to the right. Drain all the rinse water from the freezing cylinder. When the rinse water stops flowing from the door spout, move the draw handle to the left and place the control switch in the OFF position.
- Repeat step 1 and step 2 until the rinse water being drawn from the freezing cylinder is clear.
- Repeat step 1 through step 3 for the other side of the unit.

Cleaning

- Prepare an approved 100 PPM cleaning solution (examples: 2-1/2 gal. [9.5 L] of Kay-5® or 2 gal. [7.6 L] of Stera-Sheen®). Use warm water and follow the manufacturer's specifications.
- Pour the cleaning solution into the hopper and allow it to flow into the freezing cylinder.
- While the solution is flowing into the freezing cylinder, brush clean the mix hopper and mix inlet hole.
- Place the power switch in the WASH position. This will agitate the cleaning solution in the freezing cylinder.
- Place an empty pail beneath the door spout and move the draw handle to the right. Draw off all the cleaning solution. When the solution stops flowing from the door spout, move the draw handle to the left, and place the power switch in the OFF position.
- Repeat step 1 through step 5 for the other side of the unit.

Disassembly

- Make sure the control switch is in the off position.
- Remove the handscrews, freezer door, beater assembly, torque rotor, scraper blade, and drive shaft from the freezing cylinder. Take these parts to the sink for cleaning.
- Repeat step 1 through step 2 for the other side of the unit.
- Remove the front drip tray and the splash shield. Take these parts to the sink for cleaning.
- Remove the rear drip pans from the front panel.

Note: If the drip pans are filled with an excessive amount of mix, the drive shaft seals should be replaced or properly lubricated.

Brush Cleaning

- Prepare a sink with an approved 100 PPM cleaning solution (examples: Kay-5® or Stera-Sheen®). Use warm water and follow the manufacturer's specifications. If another approved cleaner is used, dilute according to label instructions.

Important! Follow the label directions. Too **strong** of a solution can cause parts damage, while too **mild** of a solution will not provide adequate cleaning. Make sure all

brushes provided with the freezer are available for brush cleaning.

2. Remove the O-ring and seal from the drive shaft. Remove the O-ring and the bearing from the torque rotor.
3. Remove the draw valve, ice buster, front bearing, gasket, and prime plug from the freezer door. Remove all O-rings.

Note: To remove the O-ring, use a single-service towel to grasp the O-ring. Apply pressure in an upward direction until the O-ring pops out of its groove. With the other hand, push the top of the O-ring forward until it rolls out of the groove and can be removed easily.

4. Thoroughly brush clean all disassembled parts in the cleaning solution, making sure all lubricant and mix film is removed. Place all the cleaned parts on a clean, dry surface to air dry.
5. Return to the freezer with a small amount of cleaning solution. Brush clean the rear shell bearing at the back of the freezing cylinder with the black bristle brush.

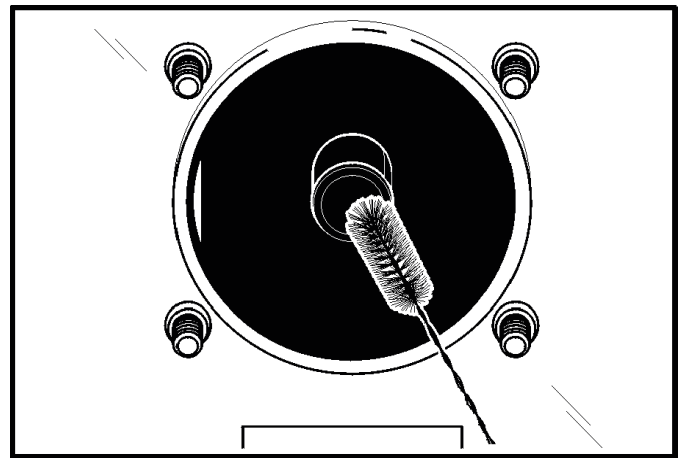

Figure 6-31

6. Wipe clean all exterior surfaces of the freezer.
7. Repeat step 1 through step 6 for the other side of the unit.

During Cleaning and Sanitizing



ALWAYS FOLLOW LOCAL HEALTH CODES.



NOTICE! Cleaning and sanitizing schedules are governed by federal, state, or local regulatory agencies, and must be followed accordingly. If the unit has a Standby mode, it must not be used in lieu of proper cleaning and sanitizing procedures and frequencies set forth by the ruling health authority. The following checkpoints should be stressed during the cleaning and sanitizing operations.



IMPORTANT! *Cleaning and sanitizing must be performed daily.*

Troubleshooting Bacterial Count

- Thoroughly clean and sanitize machine regularly, including complete disassembly and brush cleaning.
 - Use all brushes supplied for thorough cleaning. The brushes are specially designed to reach all mix passageways.
 - Use the white bristle brush to clean the air/mix feed tube, which extends from the hopper down to the rear of the freezing cylinder.
 - Use the black bristle brush to thoroughly clean the rear shell bearing located at the rear of the freezing cylinder. Be sure to have a generous amount of cleaning solution on the brush.
 - If local health codes permit the use of rerun**, make sure the mix rerun is stored in a sanitized, covered stainless steel container and used the following day. **Do not** prime the machine with rerun. When using rerun, skim off the foam and discard, then mix the rerun with fresh mix in a ratio of 50/50 during the day's operation.
- On a designated day of the week, run the mix as low as feasible and discard after closing. This will break the rerun cycle and reduce the possibility of high bacteria and coliform counts.
 - Properly prepare the cleaning and sanitizing solutions. Read and follow label directions carefully. Too **strong** of a solution may damage the parts, and too **weak** of a solution will not do an adequate job of cleaning or sanitizing.
 - The temperature of the mix in the mix hopper and walk-in cooler should be below 40°F (4.4°C).

Regular Maintenance Checks

- Replace scraper blades that are nicked, damaged, or worn down. Before installing the beater, make sure the scraper blades are properly attached.
 - Check rear shell bearing for signs of wear (excessive mix leakage in drip pan) and make sure it is properly cleaned.
 - Using a screwdriver and cloth towel, keep the rear shell bearing and the female square drive socket clean and free of lubricant and mix deposits.
 - Dispose of O-rings and seals if they are worn, torn, or fit too loosely, and replace with new.
 - Follow all lubricating procedures as outlined in "Assembly."
 - Check the condenser(s) for accumulation of dirt and lint. Dirty condensers will reduce the efficiency and capacity of the machine. Condensers should be cleaned **monthly** with a soft brush. **Never** use screwdrivers or other metal probes to clean between the fins.
- Note:** *For machines equipped with an air filter, it will be necessary to vacuum clean the filters on a monthly schedule.*

Winter Storage

If the place of business is to be closed during the winter months, it is important to protect the freezer by following certain precautions, particularly if the building is to be left unheated and subject to freezing conditions.

Disconnect the freezer from the main power source to prevent possible electrical damage. Your local Taylor distributor can perform this service for you.

Wrap detachable parts of the freezer such as beater, blades, drive shaft, and freezer door, and place in a protected dry place. Rubber trim parts and gaskets can be protected by wrapping with moisture-proof paper. All parts should be thoroughly cleaned of dried mix or lubrication accumulations, which attract mice and other vermin.

Table 8-1

Problem	Probable Cause	Remedy	Page Ref.
1. No product being dispensed.	a. Control switch is in the OFF position.	a. Place control switch in the AUTO position.	6-7
	b. Improper mixing of product.	b. Carefully follow directions for mixing product.	---
	c. Inadequate mix in hopper.	c. Fill hopper with mix.	6-7
	d. Product frozen-up in freezing cylinder.	d. Adjust viscosity adjustment accordingly.	5-1
	e. Unit out on reset.	e. Place control switch in the OFF position. Press the push-button switch. Return control switch to AUTO.	5-1
	f. Beater assembly is rotating counterclockwise.	f. If the beater is rotating counterclockwise, call service technician to correct the rotation.	1-1
	g. Unit unplugged at wall receptacle.	g. Plug in power cord.	---
	h. Tripped circuit breaker or blown fuse.	h. Reset circuit breaker or replace fuse.	---
2. Unit will not operate in the AUTO or WASH mode.	a. Unit unplugged at wall receptacle.	a. Plug in power cord.	---
	b. Tripped circuit breaker or blown fuse.	b. Reset circuit breaker or replace fuse.	---
	c. Unit out on reset.	c. Place the control switch in the OFF position. Press the push-button switch. Return control switch to AUTO.	5-1
3. No compressor operation in the AUTO mode.	a. Beater motor is out on overload.	a. Place control switch in OFF position. Press the push-button switch. Return control switch to AUTO.	5-1
	b. Condenser dirty A/C.	b. Clean condenser monthly.	7-1
4. Product too thick.	a. Inadequate mix in hopper.	a. Fill hopper with mix.	6-9
	b. Improper mixing of product.	b. Carefully follow directions for mixing product.	---
	c. The viscosity adjustment is set incorrectly.	c. Adjust the viscosity control.	5-1
	d. The torque arm is not installed.	d. Install the torque arm.	6-7
5. Product too thin.	a. Missing, incorrectly installed, or bad scraper blade.	a. Install or replace scraper blade.	6-2
	b. Improper mixing of product.	b. Carefully follow directions for mixing product.	---
	c. The viscosity adjustment is set incorrectly.	c. Adjust accordingly.	5-1
	d. Incorrect beater rotation. (Rotation must be clockwise.)	d. Contact service technician.	---
	e. Dirty condensers.	e. Clean regularly.	7-1

TROUBLESHOOTING GUIDE

Problem	Probable Cause	Remedy	Page Ref.
6. The freezing cylinder walls are scored.	a. The scraper blades and/or blade clips are damaged.	a. Replace the scraper blades and/or clips.	6-2
	b. The front bearing is missing or worn on the freezer door.	b. Install or replace the front bearing.	6-4
	c. Broken pins on beater assembly.	c. Repair or replace the beater assembly. Make sure the scraper blades are properly seated on pins.	6-2
	d. Unit was placed in AUTO before all sanitizing solution was removed from freezing cylinder.	d. Place unit in AUTO only after priming is complete and all sanitizing solution is removed.	6-8
	e. The beater assembly is bent.	e. Call service technician to repair or replace the beater and to correct the cause of insufficient mix in the freezing cylinder.	---
7. Excessive leakage into rear drip pan.	a. Improper or inadequate lubrication of drive shaft seal.	a. Use correct lubricant (Taylor Lube) and follow lubrication procedures.	6-2
	b. Bad or missing seal on drive shaft.	b. Replace seal every 3 months.	9-1
	c. Worn rear shell bearing.	c. Contact service technician for replacement.	---
8. Excessive leakage from door spout.	a. Improper or inadequate lubrication of draw valve O-rings.	a. Use correct lubricant (Taylor Lube) and follow lubrication procedures.	6-2
	b. Bad or missing O-rings on draw valve.	b. Replace O-rings every 3 months.	9-1
9. Unable to remove drive shaft.	a. Lubrication on square end of drive shaft.	a. Do not lubricate square end. Contact service technician for replacement.	6-2
	b. Rounded corners of drive shaft, drive coupling, or both.	b. Contact service technician to replace drive shaft, drive coupling, or both.	---

Table 9-1

Part Description	Every 3 Months	Every 6 Months	Annually	Quantities To Be Replaced
Drive Shaft Seal	X			2
Drive Shaft O-ring	X			2
Scraper Blade	X			2
Freezer Door Gasket	X			2
Front Bearing	X			2
Guide Bearing	X			2
Torque Rotor O-ring	X			2
Draw Valve O-rings	X			4
Purge Port O-ring	X			2
White Bristle Brush - 3" x 7"		Inspect and replace if necessary	Maximum	1
Double-Ended Brush		Inspect and replace if necessary	Maximum	1
Black Bristle Brush - 1" x 2" x 14"		Inspect and replace if necessary	Maximum	1
White Bristle Brush - 1-1/2" x 2" x 3"		Inspect and replace if necessary	Maximum	1

TAYLOR COMPANY LIMITED WARRANTY ON FREEZERS

Taylor Company is pleased to provide this limited warranty on new Taylor-branded freezer equipment available from Taylor to the market generally (the "Product") to the original purchaser only.

LIMITED WARRANTY

Taylor warrants the Product against failure due to defect in materials or workmanship under normal use and service as follows. All warranty periods begin on the date of original Product installation. If a part fails due to defect during the applicable warranty period, Taylor, through an authorized Taylor distributor or service agency, will provide a new or remanufactured part, at Taylor's option, to replace the failed defective part at no charge for the part. Except as otherwise stated herein, these are Taylor's exclusive obligations under this limited warranty for a Product failure. This limited warranty is subject to all provisions, conditions, limitations, and exclusions listed below and on the reverse (if any) of this document.

Table 10-1

Product	Part	Limited Warranty Period
Soft Serve	Insulated shell assembly	Five (5) years
Frozen Yogurt Shakes	Refrigeration compressor (except service valve)	Five (5) years
Smoothies	Beater motors	Two (2) years
Frozen Beverage	Beater drive gear	Two (2) years
Batch Desserts	Printed circuit boards and Softech controls beginning with serial number H8024200	Two (2) years
	Parts not otherwise listed in this table or excluded below	One (1) years

LIMITED WARRANTY CONDITIONS

1. If the date of original installation of the Product cannot be verified, then the limited warranty period begins ninety (90) days from the date of Product manufacture (as indicated by the Product serial number). Proof of purchase may be required at time of service.
2. This limited warranty is valid only if the Product is installed and all required service work on the Product is performed by an authorized Taylor distributor or service agency, and only if genuine, new Taylor parts are used.
3. Installation, use, care, and maintenance must be normal and in accordance with all instructions contained in the Taylor Operator's Manual.
4. Defective parts must be returned to the authorized Taylor distributor or service agency for credit.
5. The use of any refrigerant other than that specified on the Product's data label will void this limited warranty.

LIMITED WARRANTY EXCEPTIONS

This limited warranty does **not** cover:

1. Labor or other costs incurred for diagnosing, repairing, removing, installing, shipping, servicing, or handling of defective parts, replacement parts, or new Products.
2. Normal maintenance, cleaning, and lubrication as outlined in the Taylor Operator's Manual, including cleaning of condensers.

LIMITED WARRANTY ON EQUIPMENT

3. Replacement of wear items designated as Class "000" parts in the Taylor Operator's Manual.
4. External hoses, electrical power supplies, and machine grounding.
5. Parts not supplied or designated by Taylor, or damages resulting from their use.
6. Return trips or waiting time required because a service technician is prevented from beginning warranty service work promptly upon arrival.
7. Failure, damage, or repairs due to faulty installation, misapplication, abuse, no or improper servicing, unauthorized alteration, or improper operation or use as indicated in the Taylor Operator's Manual, including but not limited to the failure to use proper assembly and cleaning techniques, tools, or approved cleaning supplies.
8. Failure, damage, or repairs due to theft, vandalism, wind, rain, flood, high water, water, lightning, earthquake or any other natural disaster, fire, corrosive environments, insect or rodent infestation, or other casualty, accident or condition beyond the reasonable control of Taylor; operation above or below the electrical or water supply specification of the Product; or components repaired or altered in any way so as, in the judgment of the Manufacturer, to adversely affect performance, or normal wear or deterioration.
9. Any Product purchased over the Internet.
10. Failure to start due to voltage conditions, blown fuses, open circuit breakers, or damages due to the inadequacy or interruption of electrical service.
11. Electricity or fuel costs, or increases in electricity or fuel costs from any reason whatsoever.
12. Damages resulting from the use of any refrigerant other than that specified on the Product's data label will void this limited warranty.
13. Any cost to replace, refill, or dispose of refrigerant, including the cost of refrigerant.
- 14. ANY SPECIAL, INDIRECT, OR CONSEQUENTIAL PROPERTY OR COMMERCIAL DAMAGE OF ANY NATURE WHATSOEVER.** Some jurisdictions do not allow the exclusion of incidental or consequential damages, so this limitation may not apply to you.

This limited warranty gives you specific legal rights, and you may also have other rights which vary from jurisdiction to jurisdiction.

LIMITATION OF WARRANTY

THIS LIMITED WARRANTY IS EXCLUSIVE AND IS IN LIEU OF ALL OTHER WARRANTIES, CONDITIONS, AND/OR REMEDIES UNDER THE LAW, INCLUDING ANY IMPLIED WARRANTIES OR CONDITIONS OF MERCHANTABILITY OR FITNESS FOR A PARTICULAR PURPOSE. THE ORIGINAL OWNER'S SOLE REMEDY WITH RESPECT TO ANY PRODUCTS SHALL BE REPAIR OR REPLACEMENT OF DEFECTIVE COMPONENTS UNDER THE TERMS OF THIS LIMITED WARRANTY. ALL RIGHTS TO CONSEQUENTIAL OR INCIDENTAL DAMAGES (INCLUDING CLAIMS FOR LOST SALES, LOST PROFITS, PRODUCT LOSS, PROPERTY DAMAGES, OR SERVICE EXPENSES) ARE EXPRESSLY EXCLUDED. THE EXPRESS WARRANTIES MADE IN THIS LIMITED WARRANTY MAY NOT BE ALTERED, ENLARGED, OR CHANGED BY ANY DISTRIBUTOR, DEALER, OR OTHER PERSON, WHATSOEVER.

LEGAL REMEDIES

The owner **must** notify Taylor in writing, by certified or registered letter to the following address, of any defect or complaint with the Product, stating the defect or complaint and a specific request for repair, replacement, or other correction of the Product under warranty, mailed at least thirty (30) days before pursuing any legal rights or remedies.

Taylor Company
750 N. Blackhawk Blvd.
Rockton, IL 61072, U.S.A.

TAYLOR COMPANY LIMITED WARRANTY ON TAYLOR GENUINE PARTS

Taylor Company is pleased to provide this limited warranty on new Taylor genuine replacement components and parts available from Taylor to the market generally (the "Parts") to the original purchaser only.

LIMITED WARRANTY

Taylor warrants the Parts against failure due to defect in materials or workmanship under normal use and service as follows. All warranty periods begin on the date of original installation of the Part in the Taylor unit. If a Part fails due to defect during the applicable warranty period, Taylor, through an authorized Taylor distributor or service agency, will provide a new or remanufactured Part, at Taylor's option, to replace the failed defective Part at no charge for the Part. Except as otherwise stated herein, these are Taylor's exclusive obligations under this limited warranty for a Part failure. This limited warranty is subject to all provisions, conditions, limitations, and exclusions listed below and on the reverse (if any) of this document.

Table 11-1

Part's Warranty Class Code Or Part	Limited Warranty Period
Class 103 Parts ¹	Three (3) Months
Class 212 Parts ²	Twelve (12) Months
Class 512 Parts	Twelve (12) Months
Class 000 Parts	No Warranty

LIMITED WARRANTY CONDITIONS

1. If the date of original installation of the Part cannot be otherwise verified, proof of purchase may be required at time of service.
2. This limited warranty is valid only if the Part is installed and all required service work in connection with the Part is performed by an authorized Taylor distributor or service agency.
3. The limited warranty applies only to Parts remaining in use by their original owner at their original installation location in the unit of original installation.
4. Installation, use, care, and maintenance must be normal and in accordance with all instructions contained in the Taylor Operator's Manual.
5. Defective Parts must be returned to the authorized Taylor distributor or service agency for credit.
6. This warranty is not intended to shorten the length of any warranty coverage provided pursuant to a separate Taylor Limited Warranty on freezer or grill equipment.
7. The use of any refrigerant other than that specified for the unit in which the Part is installed will void this limited warranty.

^{1, 2} Except that Taylor Part #032129SER2 (Compressor-Air-230V SERV) and Taylor Part #075506SER1 (Compressor-Air-115V 60HZ) shall have a limited warranty period of twelve (12) months when used in Taylor freezer equipment and a limited warranty period of two (2) years when used in Taylor grill equipment.

LIMITED WARRANTY ON PARTS

LIMITED WARRANTY EXCEPTIONS

This limited warranty does **not** cover:

1. Labor or other costs incurred for diagnosing, repairing, removing, installing, shipping, servicing, or handling of defective Parts, replacement Parts, or new Parts.
2. Normal maintenance, cleaning, and lubrication as outlined in the Taylor Operator's Manual, including cleaning of condensers or carbon and grease buildup.
3. Required service, whether cleaning or general repairs, to return the cooking surface assemblies, including the upper platen and lower plate, to an operational condition to achieve proper cooking or allow proper assembly of release sheets and clips as a result of grease buildup on the cooking surfaces, including but not limited to the platen and plate, sides of the shroud, or top of the shroud.
4. Replacement of cooking surfaces, including the upper platen and lower plate, due to pitting or corrosion (or in the case of the upper platen, due to loss of plating) as a result of damage due to the impact of spatulas or other small wares used during the cooking process or as a result of the use of cleaners, cleaning materials, or cleaning processes not approved for use by Taylor.
5. Replacement of wear items designated as Class "000" Parts in the Taylor Operator's Manual, as well as any release sheets and clips for the Product's upper platen assembly.
6. External hoses, electrical power supplies, and machine grounding.
7. Parts not supplied or designated by Taylor, or damages resulting from their use.
8. Return trips or waiting time required because a service technician is prevented from beginning warranty service work promptly upon arrival.
9. Failure, damage, or repairs due to faulty installation, misapplication, abuse, no or improper servicing, unauthorized alteration, or improper operation or use as indicated in the Taylor Operator's Manual, including but not limited to the failure to use proper assembly and cleaning techniques, tools, or approved cleaning supplies.
10. Failure, damage, or repairs due to theft, vandalism, wind, rain, flood, high water, water, lightning, earthquake, or any other natural disaster, fire, corrosive environments, insect or rodent infestation, or other casualty, accident or condition beyond the reasonable control of Taylor; operation above or below the gas, electrical or water supply specification of the unit in which a part is installed; or Parts or the units in which they are installed repaired or altered in any way so as, in the judgment of Taylor, to adversely affect performance, or normal wear or deterioration.
11. Any Part purchased over the Internet.
12. Failure to start due to voltage conditions, blown fuses, open circuit breakers, or damages due to the inadequacy or interruption of electrical service.
13. Electricity, gas, or other fuel costs, or increases in electricity or fuel costs from any reason whatsoever.
14. Damages resulting from the use of any refrigerant other than that specified for the unit in which the Part is installed will void this limited warranty.
15. Any cost to replace, refill, or dispose of refrigerant, including the cost of refrigerant.
16. **ANY SPECIAL, INDIRECT, OR CONSEQUENTIAL PROPERTY OR COMMERCIAL DAMAGE OF ANY NATURE WHATSOEVER.** Some jurisdictions do not allow the exclusion of incidental or consequential damages, so this limitation may not apply to you.

This limited warranty gives you specific legal rights, and you may also have other rights which vary from jurisdiction to jurisdiction.

LIMITATION OF WARRANTY

THIS LIMITED WARRANTY IS EXCLUSIVE AND IS IN LIEU OF ALL OTHER WARRANTIES, CONDITIONS AND/OR REMEDIES UNDER THE LAW, INCLUDING ANY IMPLIED WARRANTIES OR CONDITIONS OF MERCHANTABILITY OR FITNESS FOR A PARTICULAR PURPOSE. THE ORIGINAL OWNER'S SOLE REMEDY WITH RESPECT TO ANY PRODUCTS SHALL BE REPAIR OR REPLACEMENT OF DEFECTIVE PARTS UNDER THE TERMS OF THIS LIMITED WARRANTY. ALL RIGHTS TO CONSEQUENTIAL OR INCIDENTAL DAMAGES (INCLUDING CLAIMS FOR LOST SALES, LOST PROFITS, PRODUCT LOSS, PROPERTY DAMAGES OR SERVICE EXPENSES) ARE EXPRESSLY EXCLUDED. THE EXPRESS WARRANTIES MADE IN THIS LIMITED WARRANTY MAY NOT BE ALTERED, ENLARGED, OR CHANGED BY ANY DISTRIBUTOR, DEALER, OR OTHER PERSON, WHATSOEVER.

LEGAL REMEDIES

The owner **must** notify Taylor in writing, by certified or registered letter to the following address, of any defect or complaint with the Part, stating the defect or complaint and a specific request for repair, replacement, or other correction of the Part under warranty, mailed at least thirty (30) days before pursuing any legal rights or remedies.

Taylor Company
750 N. Blackhawk Blvd.
Rockton, IL 61072, U.S.A.

