

OPERATOR'S MANUAL



Model PH61 Heat Treatment Peristaltic Pump Shake Freezer

Original Operating Instructions

048119TS

2006 (Original Publication)
(Updated 10/29/2019)

Section 1: To the Installer

Installer Safety	1-1
Site Preparation	1-1
Air-Cooled Machines	1-2
Water Connections	1-2
Electrical Connections	1-2
Beater Rotation	1-3
Refrigerant	1-3

Section 2: To the Operator

Compressor Warranty Disclaimer	2-2
--	-----

Section 3: Safety

Section 4: Operator Parts Identification

Model PH61	4-1
Beater and Door Assembly	4-3
X57028-XX Pump A. - Mix Simplified	4-5
Accessories	4-6
Syrup Valve	4-7
Brush A.-Package-HT X44127	4-8

Section 5: User Interface

Symbol Definitions	5-1
Power Switch	5-2
Liquid Crystal Display	5-2
Indicator Lights	5-2
Reset Mechanism	5-2
Operating Screen Descriptions	5-3
Operator Menu	5-6

Table of Contents

Section 6: Operating Procedures

Machine Setup	6-1
Sanitizing	6-8
Priming	6-10
Daily Closing Procedures	6-10
Daily Opening Procedures	6-13
Setup—Complete the Following	6-13
Syrup Calibration and Priming	6-15
Closing Procedures	6-17
Disassembly	6-19
Brush-Cleaning	6-21
Sanitizing the Syrup Lines	6-21
Pump Tube Replacement	6-22
Pump Tube Installation	6-23

Section 7: Operator’s Checklist

During Cleaning and Sanitizing	7-1
Troubleshooting Bacterial Count	7-1
Regular Maintenance Checks	7-1
Winter Storage	7-2

Section 8: Troubleshooting Guide

Section 9: Parts Replacement Schedule

Section 10: Limited Warranty on Equipment

Section 11: Limited Warranty on Parts

The following information has been included in the manual as safety and regulatory guidelines. For complete installation instructions, please see the Installation Checklist.

Installer Safety



IMPORTANT! In all areas of the world, machines should be installed in accordance with existing local codes. Please contact your local authorities if you have any questions.

Care should be taken to ensure that all basic safety practices are followed during the installation and servicing activities related to the installation and service of Taylor® machines.

- Only Taylor service personnel should perform installation, maintenance, and repairs on Taylor machines.
- Authorized service personnel should consult OSHA Standard 29CFR1910.147 or the applicable code of the local area for industry standards on lockout/tagout procedures before beginning any installation or repairs.
- Authorized service personnel must ensure that the proper personal protective equipment (PPE) is available and worn when required during installation and service.
- Authorized service personnel must remove all metal jewelry, rings, and watches before working on electrical equipment.



DANGER! The main power supply(s) to the machine must be disconnected prior to performing any repairs. Failure to follow this instruction may result in personal injury or death from electrical shock or hazardous moving parts, as well as poor performance or damage to the machine.



WARNING! This machine has many sharp edges that can cause severe injuries.

Site Preparation

Review the area where the machine will be installed. Make sure that all possible hazards to the installer, user, and the machine have been addressed.



WARNING! Only install this machine in a location where its use and maintenance is restricted to trained personnel. Failure to comply may result in personal injury.

For Indoor Use Only: This machine is designed to operate indoors, under normal ambient temperatures of 70°F to 75°F (21°C to 24°C). The machine has successfully performed in high ambient temperatures of up to 104°F (40°C) at reduced capacities.



WARNING! This machine must **NOT** be installed in an area where a water jet or hose can be used. **NEVER** use a water jet or hose to rinse or clean the machine. Failure to follow this instruction may result in electrocution.



CAUTION! This machine must be installed on a level surface to avoid the hazard of tipping. Extreme care should be taken in moving this machine for any reason. Two or more persons are required to safely move this machine. Failure to comply may result in personal injury or damage to the machine.

The authorized installer should inspect the machine and promptly report any damage to the local authorized Taylor distributor.

This machine is made using USA sizes of hardware. All metric conversions are approximate and vary in size.

Air-Cooled Machines

Do not obstruct the machine's air intake and discharge openings. Air-cooled machines require a minimum of 6 in. (152 mm) of clearance around all sides of the machine. Failure to allow adequate clearance can reduce the refrigeration capacity of the machine and possibly cause permanent damage to the compressors.

1

Water Connections

(Water-Cooled Machines Only)

An adequate cold water supply must be provided with a hand shutoff valve. On the rear of the machine, 2-3/8 in. IPS water connections for inlet and outlet have been provided for easy hookup. The 1/2 in. inside diameter water lines should be connected to the machine. (Flexible lines are recommended, if local codes permit.) Depending on local water conditions, it may be advisable to install a water strainer to prevent foreign substances from clogging the automatic water valve. There will be only one water-in and one water-out connection. **Do not** install a hand shutoff valve on the water-out line! Water should always flow in this order: first, through the automatic water valve; second, through the condenser; and third, through the outlet fitting to an **open trap drain**.



IMPORTANT! A backflow prevention device is required on the incoming water connection side. Please see the applicable national, state, and local codes for determining the proper configuration.

Electrical Connections



IMPORTANT! In the United States, this machine is intended to be installed in accordance with the National Electrical Code (NEC), ANSI/NFPA 701987. The purpose of the NEC code is the practical safeguarding of persons and property from hazards arising from the use of electricity. This code contains provisions considered necessary for safety.

In all other areas of the world, the machine should be installed in accordance with the existing local codes. Please contact your local authorities if you have any questions.

Each machine requires one power supply for each data

label on the machine. Check the data label(s) on the machine for branch circuit overcurrent protection or fuse, circuit ampacity, and other electrical specifications.

See the wiring diagram provided inside the electrical box for proper power connections.



FOLLOW YOUR LOCAL ELECTRICAL CODES.



WARNING! This machine must be properly grounded. Failure to do so can result in severe personal injury from electrical shock.



IMPORTANT! An equipotential grounding lug is provided with this machine. Some countries require the grounding lug to be properly attached to the rear of the frame by the authorized installer. The installation location is marked by the equipotential bonding symbol (5021 of IEC 60417-1) on both the removable panel and the machine's frame.



IMPORTANT!

- Stationary machines which are not equipped with a power cord and a plug or another device to disconnect the machine from the power source must have an all-pole disconnecting device with a contact gap of at least 0.125 in. (3 mm) in the external installation.
- Machines that are permanently connected to fixed wiring and for which leakage currents may exceed 10 mA, particularly when disconnected or not used for long periods, or during initial installation, shall have protective devices to protect against the leakage of current, such as a GFI, installed by authorized personnel to local codes.
- Supply cords used with this machine shall be oil-resistant, sheathed flexible cable not lighter than ordinary polychloroprene or other equivalent synthetic elastomer-sheathed cord (code designation 60245 IEC 57) installed with the proper cord anchorage to relieve conductors from strain, including twisting, at the terminals

and protect the insulation of the conductors from abrasion.

If the supply cord is damaged, it must be replaced by a Taylor service technician to avoid a hazard.

Beater Rotation



NOTICE! Beater rotation must be clockwise as viewed looking into the freezing cylinder.

To correct the rotation on a three-phase machine, interchange any two incoming power supply lines at the freezer main terminal block only. To correct rotation on a single-phase machine, exchange leads inside the beater motor. (Follow the diagram printed on the motor.)

Electrical connections are made directly to the terminal block provided in the main control box, located behind the service panel.

It is recommended that beater rotation adjustment be performed by an authorized Taylor service technician.

Refrigerant



CAUTION! This machine contains fluorinated greenhouse gases (F-Gas) to provide refrigeration using a hermetically sealed circuit or within foam insulation. This machine's type of gas, quantity, Global Warming Potential (GWP), and CO₂ tonnes equivalent information is recorded on the machine's data label. The refrigerant used is generally considered nontoxic and nonflammable. However any gas under pressure is potentially hazardous and must be handled with caution.

NEVER fill any refrigerant cylinder completely with liquid. Filling the cylinder approximately 80% will allow for normal expansion.



CAUTION! Use only approved refrigerant listed on the machine's data-label or authorized through a manufacturer's technical bulletin. The use of any other refrigerant may expose users and operators to unexpected safety hazards.



WARNING! Refrigerant liquid sprayed onto the skin may cause serious damage to tissue. Keep eyes and skin protected. If refrigerant burns should occur, flush the area immediately with cold water. If burns are severe, apply ice packs and contact a physician immediately.



NOTICE! Taylor reminds technicians to be aware of and in compliance with local government laws regarding refrigerant recovery, recycling, and reclaiming systems. For information regarding applicable local laws, please contact your local authorized Taylor distributor.



IMPORTANT! Refrigerants and their associated lubricants may be extremely moisture absorbent. When opening a refrigeration system, the maximum time the system is open must not exceed 15 minutes. Cap all open tubing to prevent humid air or water from being absorbed by the oil.

The machine you have purchased has been carefully engineered and manufactured to give you dependable operation. When properly operated and cared for, it will produce a consistent quality product. Like all mechanical products, this machine will require cleaning and maintenance. A minimum amount of care and attention is necessary if the operating procedures outlined in this manual are followed closely.



IMPORTANT! This manual should be read before operating or performing any maintenance on your machine.

The Model PH61 will **not** compensate and correct for any errors during the setup or filling operations. Thus, the initial assembly and priming procedures are of extreme importance. It is strongly recommended the personnel responsible for the machine's operation, both assembly and disassembly, study these procedures to be properly trained.

When your machine is delivered or if it has been in the OFF position for more than 24 hours, disassemble the machine following procedures found on page 6-17. Follow assembly procedures on page 6-1 to re-assemble your machine.



IMPORTANT! Dairy products are susceptible to bacterial contamination due to improper product handling. Therefore, be sure to use clean sanitary conditions when handling mix.

The machine must be disassembled, cleaned, sanitized, and lubricated every 2 weeks.



ALWAYS FOLLOW LOCAL HEALTH CODES.

If you require technical assistance, please contact your local authorized Taylor distributor.

Important! Your Taylor warranty is valid only if the parts are authorized Taylor parts, purchased from the local authorized Taylor distributor, and only if all required service work is provided by Taylor service technicians. Taylor reserves the right to deny warranty claims on machines or parts if unapproved parts or incorrect refrigerant were installed in the machine, system modifications were performed beyond factory recommendations, or it is determined that the failure was caused by abuse, misuse, neglect, or failure to follow all operating instructions. For full details of your Taylor warranty, please see the Limited Warranty section in this manual.

During the Heat Treatment process, the product is brought to a temperature sufficient to destroy bacteria and is returned to a standby temperature.

The special control system will ensure the product is heated and maintained at the set temperature for the full 30 minutes. This time is required to ensure that bacteria is destroyed. If the machine was unable to complete the Heat cycle, the LCD will read:

HEAT TREAT CYCLE FAILURE - FREEZER LOCKED - PRESS SEL KEY

If this is the case, or if you require technical assistance, please contact your local authorized Taylor distributor.



IMPORTANT! If the crossed-out wheeled bin symbol is affixed to this machine, it signifies that this machine is compliant with the EU directives as well as other similar end-of-life legislation in effect after August 13, 2005. Therefore, it must be collected separately after its use is completed and cannot be disposed as unsorted municipal waste.

The user is responsible for delivering the machine to the appropriate collection facility as specified by your local code.

For additional information regarding applicable local disposal laws, please contact the municipal waste facility and/or local authorized Taylor distributor.

Compressor Warranty Disclaimer

The refrigeration compressor(s) on this machine are warranted for the term stated in the Limited Warranty section in this manual. However, due to the Montreal Protocol and the U.S. Clean Air Act Amendments of 1990, many new refrigerants are being tested and developed, thus seeking their way into the service industry. Some of these new refrigerants are being advertised as drop-in replacements for numerous applications. It should be noted that in the event of ordinary service to this machine's refrigeration system, **only the refrigerant specified on the affixed data label should be used.** The unauthorized use of alternate refrigerants will void your Taylor compressor warranty. It is the machine owner's responsibility to make this fact known to any technician they employ.

It should also be noted that Taylor does not warrant the refrigerant used in its machine. For example, if the refrigerant is lost during the course of ordinary service to this machine, Taylor has no obligation to either supply or provide replacement refrigerant either at billable or unbillable terms. Taylor will recommend a suitable replacement if the original refrigerant is banned, obsoleted, or no longer available during the 5-year Taylor warranty of the compressor.

From time to time Taylor may test new refrigerant alternates. Should a new refrigerant alternate prove, through Taylor's testing, that it would be accepted as a drop-in replacement for this machine, then the disclaimer in this Compressor Warranty Disclaimer section will not apply to the use of the alternate refrigerant approved by Taylor.

To find out the current status of an alternate refrigerant as it relates to your compressor warranty, call Taylor or your local authorized Taylor distributor. Be prepared to provide the model/serial number of the machine in question.

Note: *Continuing research results in steady improvements; therefore, information in this Operator's Manual is subject to change without notice.*

We at Taylor are concerned about the safety of operators at all times when they are coming in contact with the machine and its parts. Taylor makes every effort to design and manufacture built-in safety features to protect both operators and service technicians.

Installing and servicing refrigeration machines can be hazardous due to system pressure and electrical components. Only trained and qualified service personnel should install, repair, or service refrigeration machines. When working on refrigeration machines, observe precautions noted in the literature, tags and labels attached to the machine, and other safety precautions that may apply. Follow all safety code requirements. Wear safety glasses and work gloves.



DANGER! Failure to adhere to the following safety precautions may result in severe personal injury or death. Failure to comply with these warnings may also damage the machine and/or its components. Such damage may require component replacement and service repair expenses.



NOTICE! DO NOT operate this machine without reading this entire manual first. Failure to follow all of these operating instructions may result in damage to the machine, poor performance, health hazards, or personal injury.



IMPORTANT! *This machine is to be used only by trained personnel. It is not intended for use by children or people with reduced physical, sensory, or mental capabilities or lack of experience and knowledge, unless given supervision or instruction concerning the use of the machine by a person responsible for their safety. Children should be supervised to ensure that they do not play with the machine.*



WARNING! Avoid injury.

- **DO NOT** operate the machine unless it is properly grounded.
- **DO NOT** operate the machine with fuses larger than specified on the machine's data label.
- All repairs should be performed by an authorized Taylor service technician.
- The main power supplies to the machine must be disconnected prior to performing installation, repairs, or maintenance.
- Machines that are permanently connected to fixed wiring and for which leakage currents may exceed 10 mA, particularly when disconnected or not used for long periods, or during initial installation, shall have protective devices to protect against the leakage of current, such as a GFI, installed by the authorized personnel to local codes.
- Stationary machines that are not equipped with a power cord and a plug or another device to disconnect the appliance from the power source must have an all-pole disconnecting device with a contact gap of at least 0.125 in. (3 mm) in the external installation.
- Supply cords used with this machine shall be oil-resistant, sheathed flexible cable not lighter than ordinary polychloroprene or other equivalent synthetic elastomer-sheathed cord (code designation 60245 IEC 57) installed with the proper cord anchorage to relieve conductors from strain, including twisting, at the terminals and protect the insulation of the conductors from abrasion.
- If the supply cord is damaged, it must be replaced by a Taylor service technician to avoid a hazard.

Failure to follow these instructions may result in electrocution. Contact your local authorized Taylor distributor for service.



IMPORTANT! An equipotential grounding lug is provided with this machine. Some countries require the grounding lug to be properly attached to the rear of the frame by the authorized installer. The installation location is marked by the equipotential bonding symbol (5021 of IEC 60417-1) on both the removable panel and the machine's frame.



WARNING! DO NOT use a water jet to clean or rinse the machine. Failure to follow these instructions may result in serious electrical shock.

3



WARNING! Avoid injury.

- **DO NOT** allow untrained personnel to operate this machine.
- **DO NOT** operate the machine unless all service panels and access doors are fastened with screws.
- **DO NOT** remove any internal operating parts (including, but not limited to the freezer door, beater, or scraper blades) unless all control switches are in the OFF position.

Failure to follow these instructions may result in severe personal injury, especially to fingers or hands, from hazardous moving parts.



WARNING! This machine has many sharp edges that can cause severe injuries.

- **DO NOT** put objects or fingers near the shaver or the pitcher blades.
- **USE EXTREME CAUTION** when removing blades that are very sharp.

Failure to follow this instruction may result in contaminated product or personal injury from blade contact.



CAUTION! This machine must be placed on a level surface. Extreme care should be taken when moving for any reason. Two or more persons are required to safely move this machine. Failure to comply may result in personal injury or damage to the machine.



IMPORTANT! Access to the service area of the machine must be restricted to persons having knowledge and practical experience with the machine, in particular as far as safety and hygiene are concerned.



NOTICE! Cleaning and sanitizing schedules are governed by your federal, state, or local regulatory agencies and must be followed accordingly. Please refer to the cleaning section of this manual for the proper procedure to clean this machine.



CAUTION! This machine is designed to maintain product temperature under 41°F (5°C). Any product being added to this machine must be below 41°F (5°C). Failure to follow this instruction may result in health hazards and poor machine performance.

Important! Do not draw product during the Heat cycle because of high product temperatures.



DANGER! Some consumers are highly allergic to strawberries. In some severe cases, allergic reactions to strawberries can cause death.

When blending natural strawberry products, make sure excess product is removed from the pitcher to eliminate product carryover.

Do not obstruct air intake and discharge openings: 6 in. (152 mm) minimum airspace on all sides. Failure to follow this instruction may cause poor freezer performance and damage to the machine.

For Indoor Use Only: This machine is designed to operate indoors, under normal ambient temperatures of 70°F to 75°F (21°C to 24°C). The machine has successfully performed in high ambient temperatures of up to 104°F (40°C) at reduced capacities.

Do not run the machine without product. Failure to follow this instruction can result in damage to the machine.

NOISE LEVEL: Airborne noise emission does not exceed 78 dB(A) when measured at a distance of 39 in. (1.0 m) from the surface of the machine and at a height of 63 in. (1.6 m) from the floor.

Model PH61

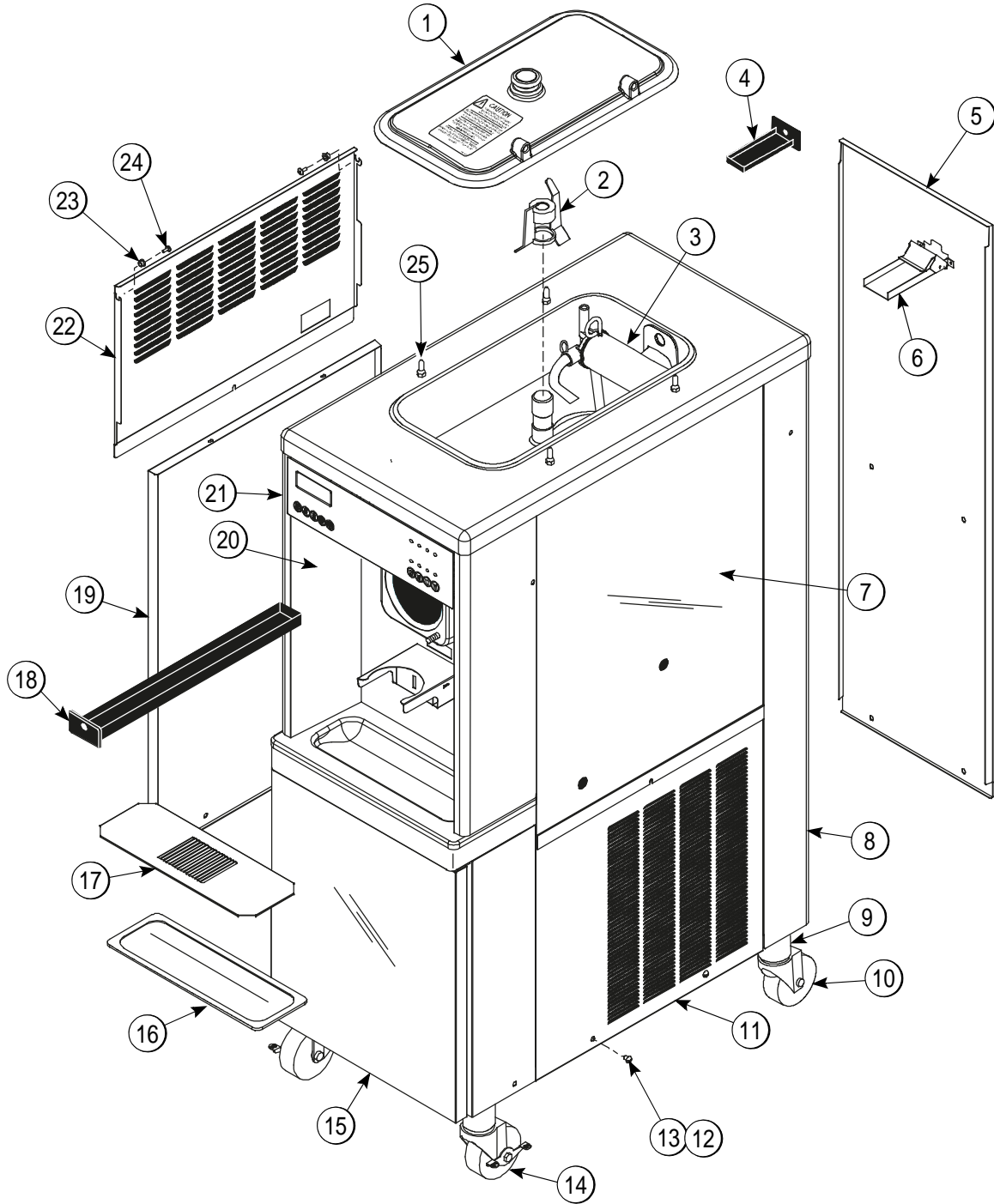

4

Figure 4-1

OPERATOR PARTS IDENTIFICATION

Model PH61 Parts Identification List

Item	Description	Part No.
1	Kit A.-Cover-Hopper	X65369
2	Agitator	X44797
3	Pump A.-Mix Simplified Shake	X57028-14
4	Pan-Drip-HT	048204
5	Panel-Rear	048203
6	Guide A.-Drip Pan-Mix Pump	X48228
7	Panel-Side-Upper-Right	056013
8	Trim-Rear Corner Right	045517
*	Trim-Rear Corner Left	045516
9	Adaptor A.-Caster	X18915
10	Caster-SWV 5/8 Stem - 4" Wheel	018794
11	Panel-Lower-Side-Right	034680
12	Screw-1/4-20x3/8-RHM-SS	011694

Item	Description	Part No.
13	Fastener-Clip 1/4-20 U	045865
14	Caster-4" SWV 5/8 Stem w/Brake	034081
15	Door A.-Syrup Cabinet	X45325
16	Tray-Drip 14-7/8L x 5-1/8 SG	013690
17	Shield-Splash - 15"L	022763
18	Pan A.-Drip	X28142
19	Panel A.-Lower Side	X24397-SER
20	Panel A.-Front	X55436
21	Decal-DEC	052280
22	Panel-Side-Upper-Left	056012
23	Washer-Plastic Pivot	013808
24	Screw-10-24x1/2 Torx Trus	002077
25	Pin-Retaining-Hopper Cover	043934

*Not Shown

Beater and Door Assembly

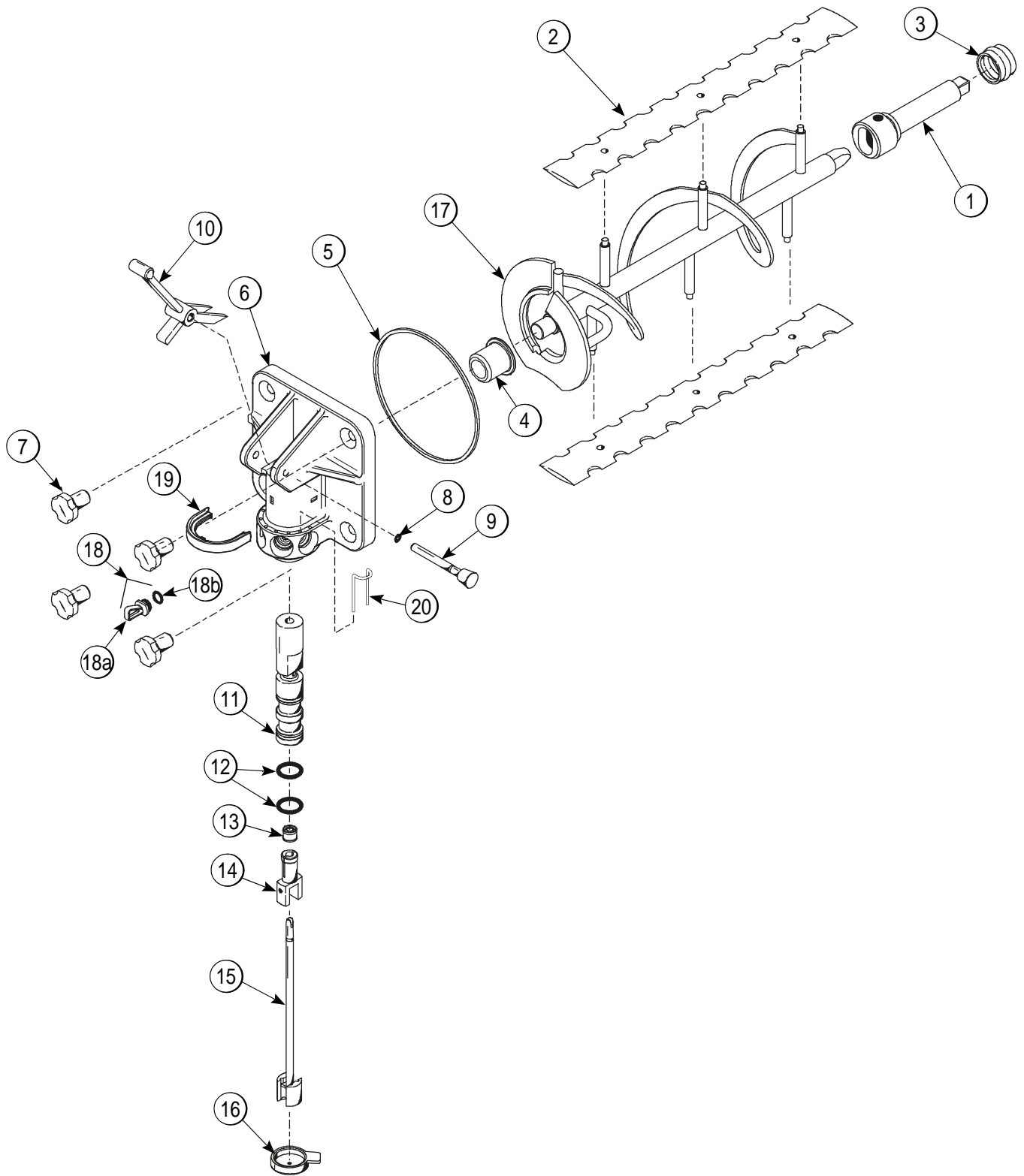

4

Figure 4-2

OPERATOR PARTS IDENTIFICATION

Beater and Door Assembly Parts Identification List

Item	Description	Part No.
1	Shaft-Beater*7QT Fluted	050985
2	Blade-Scraper-FCB 16L	041103
3	Seal-Driveshaft	032560
4	Bearing-Door-Front 1.390	055605
5	O-ring-6 IN ODX5 3/4 IDX 1/8	033493
6	Door-1SPT 4FLV HT TTS	X55937-SER
7	Nut-Stud	034034
8	O-ring-5/16 OD x .070W	016272
9	Pin A.-Pivot	X22820
10	Handle-Draw Valve	034003
11	Valve A.-Draw-Aluminum	X42210
12	O-ring-1-1/16 OD x.139W	020571

Item	Description	Part No.
13	Seal-Spinner Shaft	036053
14	Spinner	034054
15	Blade A.-Spinner	X41895
16	Cap-Restrictor	033107
17	Beater A.-7QT-Fluted	X50958
18	Kit A.-Syrup Plug Kit TTS	X58474
18a	Plug-Syrup Port TTS	053867
18b	O-ring-11MM ID x 2MM W Green	053890
*18c	Tool-Seal Install-Remove	035460
19	Retainer-Valve Pin *TTS*	054690
20	Retainer-Syrup Valve *TTS* Metal	054554

*Not Shown

4

X57028-XX Pump A. - Mix Simplified

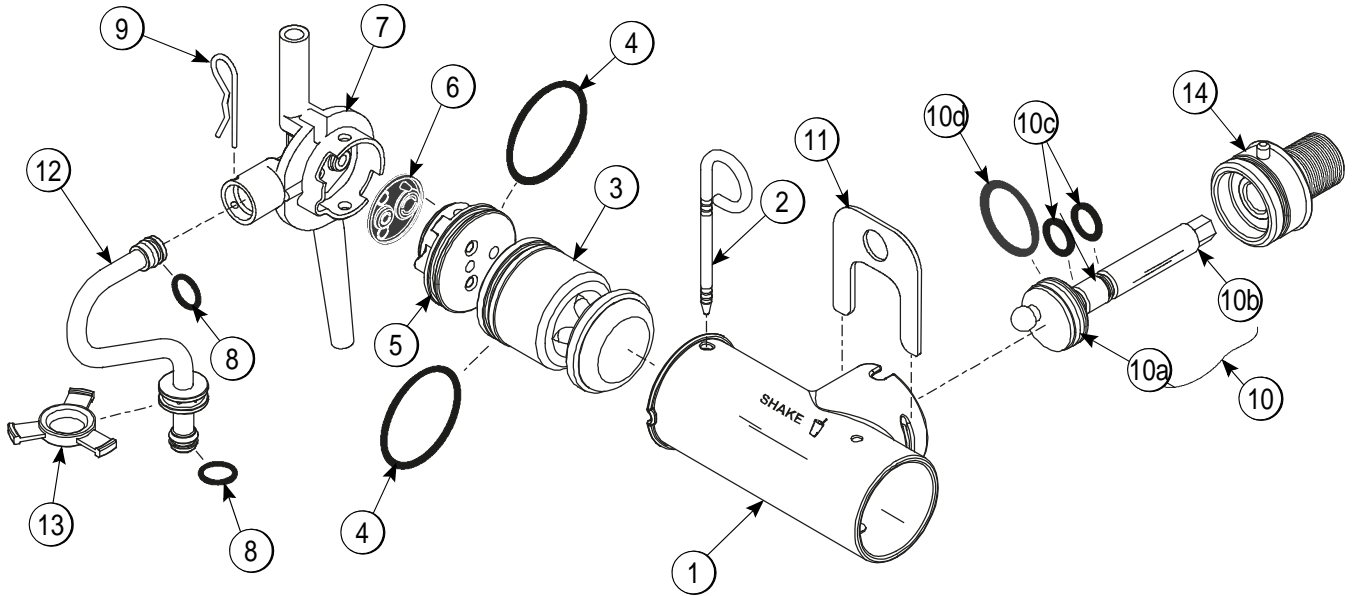

4

Figure 4-3

Item	Description	Part No.
1-7	Pump A.-Mix Simplified Shake	X57028-14
1	Cylinder-Pump Hopper Shake	057944
2	Pin-Retaining	X55450
3	Piston-Pump-Simplified	053526
4	O-ring-PKG *50 to Bag*	020051
5	Cap-Valve Body Shake	056873-14
6	Gasket-Simplified Pump Valve	053527
7	Adaptor-Mix Inlet-Shake- Blue	054944
8	O-ring-PKG *50 to Bag*	016132-SER
9	Pin-Cotter-Hairpin-1/8DIA	044731

Item	Description	Part No.
10	Shaft A.-Drive-Mix Pump- Hopper	X41947
10a	Crank-Drive-Hopper Mix Pump	039235
10b	Shaft-Drive-Mix Pump-Hopper	041948
10c	O-ring-PKG *25 to Bag*	048632
10d	O-ring-PKG *25 to Bag*	008904
11	Clip-Retainer-Mix Pump	044641
12	Tube A.-Feed-Hopper- Shake	X56522
13	Ring-Check-Feed-Tube	056524
14	Sleeve A.-Mix Pump	X44761

Accessories

4

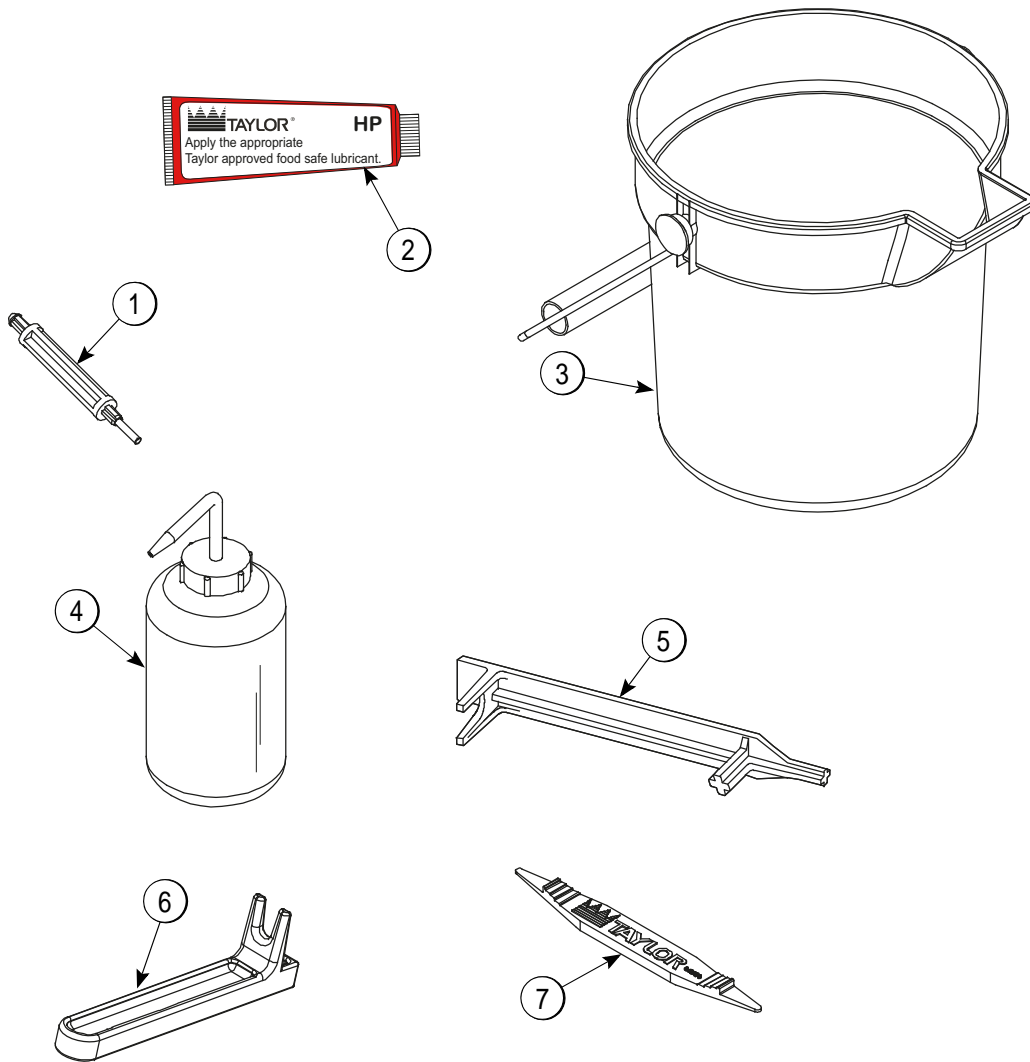

Figure 4-4

Item	Description	Part No.
1	Tool-Seal Install- Remove	035460
2	Lubricant-Taylor Hi-Perf	048232
3	Pail-10 Qt.	013163
4	Bottle-Wash-Plastic	044818
5	Tool-Shaft-Drive-Pump	047919
6	Tool-Mix Pump Shaft Removal	057167
7	Tool-O-ring Removal	048260VWHT

Item	Description	Part No.
*8	Kit A.-Parts Tray Simp Pump (Consists of 044118 and 056525)	X58447
*9	Kit A.-Tune Up SMP Pump	X49463-64
*10	Kit A.-Retainer Holder	X54560
*11	Tube A.-Pump-Peristaltic	X81509
*12	Kit A.-Syrup Plug Kit TTS	X58474
*13	Brush A.-Package-HT	X44127
*14	Sanitizer-Stera Sheen - Green	055492

*Not Shown

Syrup Valve

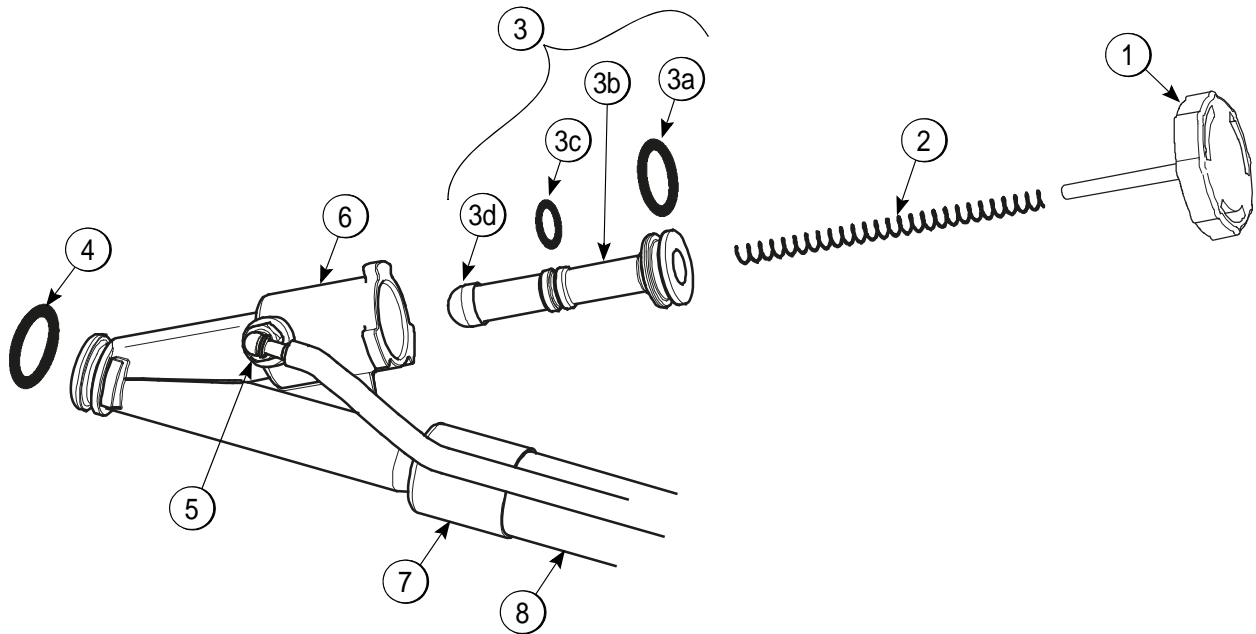

4

Figure 4-5

Item	Description	Part No.
1-6	Valve-Syrup	053874
1	Cap-Syrup Valve	053874-001
2	Spring-Syrup Valve	053874-003
3	Plunger-Syrup Valve w/Seals	053874-009
3a	O-ring-Syrup Valve Plunger L	053874-007
3b	Plunger-Syrup	053874-002
3c	O-ring-Syrup Valve Plunger S	053874-006
3d	Seal-Syrup Valve Plunger	053874-008

Item	Description	Part No.
4	O-ring-11 MM x 2MM	053890
5	Fitting-Syrup Valve	053874-004
6	Body-Syrup Valve	053874-005
7	Ferrule- .625 ID Brass	053036
8	Tube-Twinned Syrup	054580-86
*	Kit A.-Repair Valve	054595

*Not Shown

Brush A.-Package-HT X44127

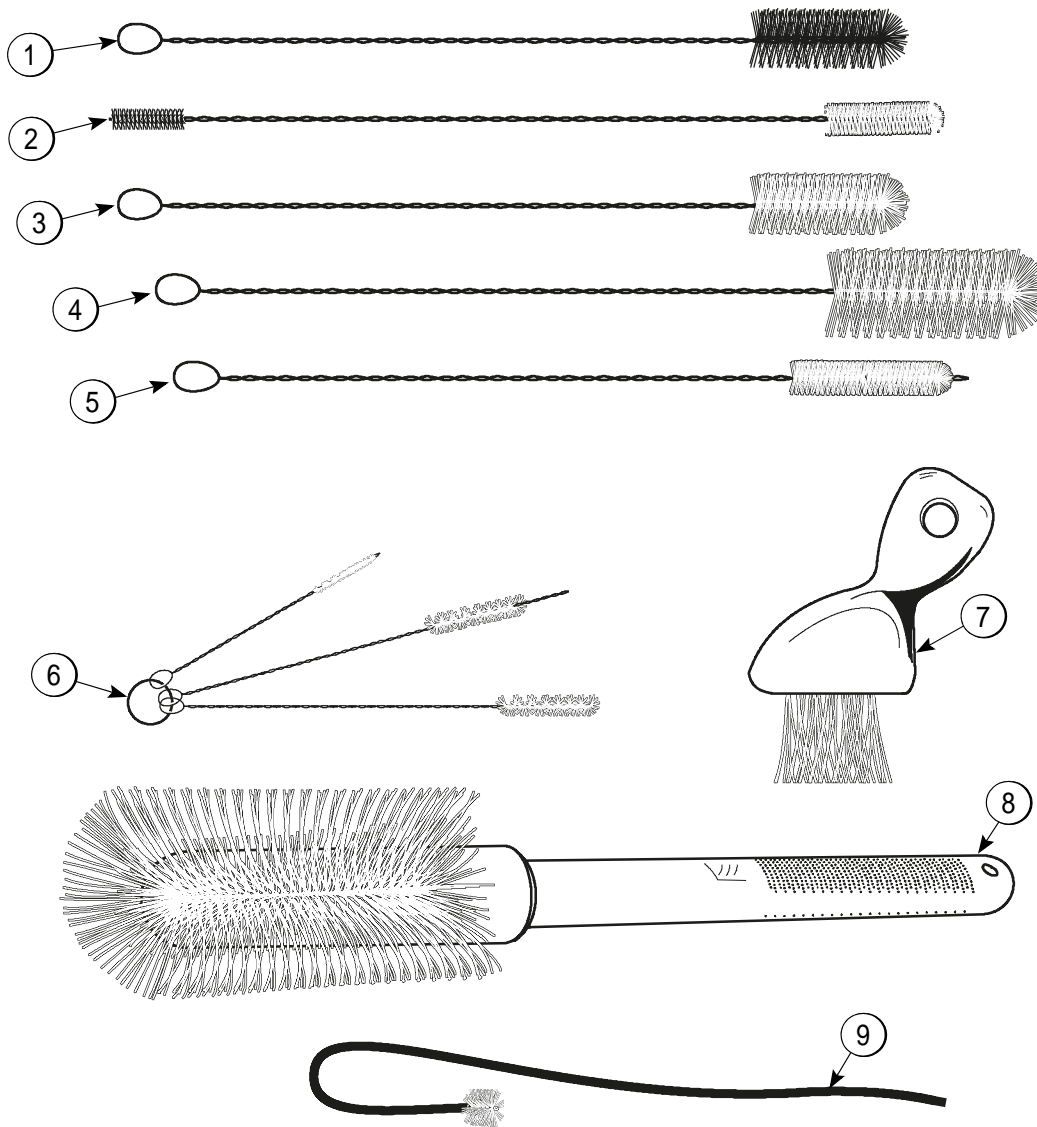

Figure 4-6

Item	Description	Part No.
1	Brush-Rear BRG 1"D x 2"LG x 14	013071
2	Brush-Double End	013072
3	Brush-Draw Valve 1"OD x 2"x17"	013073
4	Brush-Draw Valve 1-1/2"OD x 3"	014753

Item	Description	Part No.
5	Brush-1/2" DIA	033059
6	Brush-Set LVB	050103
7	Brush-End-Door-Spout	039719
8	Brush-Mix Pump Body- 3" x 7"	023316
9	Brush-Pump Spout	054068

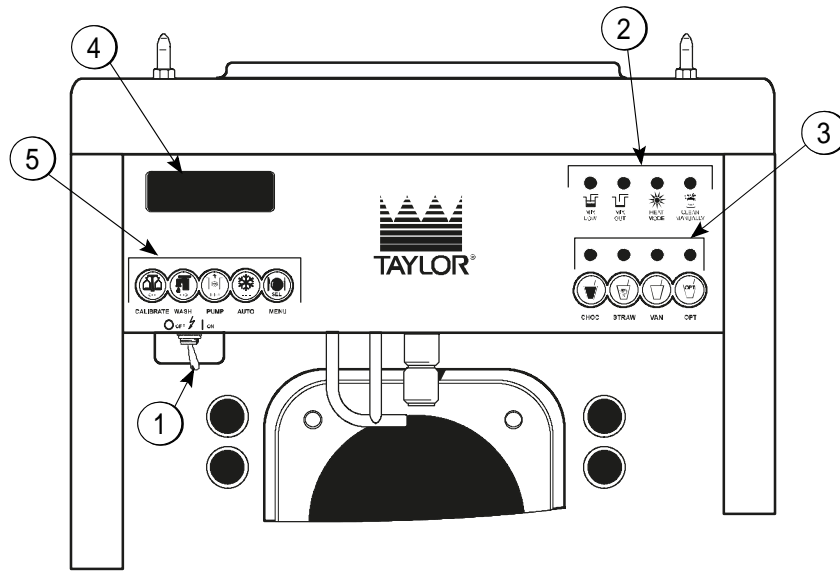

Figure 5-1

Table 5-1

Item	Description
1	Power Switch
2	Indicator Lights
3	Flavor Selector Keypad
4	Liquid Crystal Display
5	Keypads

Symbol Definitions

To better communicate in the international arena, the words on many of our operator switches and buttons have symbols to indicate their functions. Your Taylor machine is designed with these international symbols.

The following chart identifies the symbol definitions used on the operator switches.

= OFF

= POWER

= ON

= CALIBRATE

= WASH

= PUMP

= AUTO

=MENU

=MIX LOW

=MIX OUT

=HEAT MODE

=CLEAN MANUALLY/BRUSH-CLEAN

= CHOCOLATE

= STRAWBERRY

= VANILLA

= OPTIONAL

Power Switch

The power switch is under the control panel on the left-hand side of the machine. When placed in the ON position, the power switch allows Softech™ panel operation.

Liquid Crystal Display

The Liquid Crystal Display (LCD) is on the front control panel. The LCD shows what mode the freezer is operating and whether or not there is sufficient mix.

Indicator Lights

MIX LOW—When the MIX LOW light begins to flash, the mix hopper has a low supply of mix and should be refilled as soon as possible. The word **LOW** will also display on the LCD indicator next to the word **MIX**.

MIX OUT—When the MIX OUT light begins to flash, the mix hopper has been almost completely exhausted and has an insufficient supply of mix to operate the freezer. The word **OUT** will also display on the LCD indicator next to the word **MIX**. At this time, the Auto mode is locked out and the freezer will be placed in the Standby mode. To initiate the refrigeration system, add mix to the mix hopper and press the AUTO key. The freezer will automatically begin operation.

HEAT MODE—When the HEAT MODE light is flashing, the freezer is in the process of a Heat cycle.

CLEAN MANUALLY—When the CLEAN MANUALLY light is flashing, the machine must be disassembled and brush-cleaned within 24 hours.

When all four indicator lights are flashing, this signifies a locked condition. Once a hard lock condition has been remedied, two lights will remain flashing until the MIX LOW and MIX OUT conditions have been satisfied. During a soft lock condition, all four lights will stop flashing once the machine has been placed in a Heat cycle.

Reset Mechanism

The RESET button is in the right-side panel. The reset mechanism protects the beater motor from overloading. Should an overload occur, the reset mechanism will trip. To properly reset the freezer, place the power switch in the OFF position. Press the RESET button firmly. Turn the power switch to the ON position. Clear the fault. Press the WASH key and observe the freezer's performance. Open the side access panel to check if the beater motor is turning the driveshaft in a clockwise (from the operator end) direction without binding.



DANGER! DO NOT use metal objects to press the RESET button. Failure to comply may result in severe personal injury or death.

If the beater motor is turning properly, press the WASH key to cancel the cycle. Press the AUTO key to resume normal operation. If the machine shuts down again, contact a Taylor service technician.

Operating Screen Descriptions

When the machine is powered, the system will initialize. The screen will display INITIALIZING. There are four types of data the system will check: LANGUAGE, SYSTEM DATA, CONFIG DATA, and LOCKOUT DATA. During the INITIALIZING... LANGUAGE screen, the alarm will be on. If the system data, configuration data, or lockout history data has become corrupt, the following screen will alert the operator that the system settings may have been changed:

**NVRAM FAULT
RESET TO DEFAULTS
PRESS SEL KEY**

Once the system has initialized, the SAFETY TIMEOUT screen is displayed and the alarm is turned on.

**SAFETY TIMEOUT
ANY KEY ABORTS**

This screen will be displayed, with the alarm on, for 60 seconds or until any key is pressed.

After the safety timeout has been completed and the power switch is OFF, one of the following screens is displayed.

The first screen is displayed if the machine is not in a brush-clean state. If any of the requirements for a brush-clean have not been met, the time displayed will remain at 5 minutes. When all the requirements for a brush-cleaning are met and the 5 minutes expire, the screen will change to the second screen, which is the standard POWER SWITCH OFF screen.

POWER SWITCH OFF
TIME: 4:40
HOPPER: 62.1
BARREL: 67.7

POWER SWITCH OFF
- - - - -
UNIT CLEANED

When the power switch is set in the ON position, the system mode of operation screen is displayed. In this example, the machine is ON but no mode of operation has been selected. The second line of the display indicates whether there is a sufficient supply of mix in the hopper or if there is a LOW or OUT mix condition. The third line of the display shows the temperature of the mix hopper. After pressing the AUTO key, the last line of the display shows the month and date (MM = month, DD = day) that the machine needs to be disassembled and brush-cleaned.

MODE: OFF
HOPPER TEMP: 35.5F
UNIT CLEANED

The next display indicates the freezer is operating in two different modes. The following information is given:

The machine is operating in the Wash and Pump modes, the temperature of the mix hopper is 40°F (4.4°C), and the machine needs to be brush-cleaned on October 31st.

MODE: WSH-PMP
HOPPER TEMP: 40.0 F
BRUSH CLEAN ON: 10/31

USER INTERFACE

The following displays pertain to the Heat cycle:

While in the Heating phase, you will see this display. It shows the present temperature of the hopper.

```
MODE: HEAT
PHASE: HEAT
HOPPER TEMP: 140.0 F
BRUSH CLEAN ON: MM/DD
```

The mix temperature must be raised above 151°F (66.1°C) within 90 minutes or the freezer will be locked in Standby, and the cycle failure display will appear.

In the example, the hopper temperature is 140°F (60°C). The phase shows that the machine is in the Heat phase of the Heat Treatment cycle.

When the Heat phase is complete, the freezer goes into the Hold phase of the cycle. The Hold phase will hold the temperature above 151°F (66.1°C) for a minimum of 30 minutes.

5 In this example, the hopper temperature is 151°F (66.1°C).

```
MODE: HEAT
PHASE: HOLD
HOPPER TEMP: 151.0 F
BRUSH CLEAN ON: MM/DD
```

The final phase of the Heat Treatment cycle is the Cool phase. Now the freezer must cool the mix below 41°F (5°C). If the product fails to cool in 2 hours, the freezer will lock out.

This example illustrates that the temperature is being lowered but has not yet reached the set point.

```
MODE: HEAT
PHASE: COOL
HOPPER TEMP: 55.0 F
BRUSH CLEAN ON: MM/DD
```

The entire Heat Treatment cycle must be completed in 4 hours.

When the entire Heat cycle has been completed, the normal display will show the machine in the Standby mode. The machine may now be placed in the Auto mode or left in the Standby mode.

```
MODE: STANDBY
HOPPER TEMP: 41.0 F
BRUSH CLEAN ON: MM/DD
```

Hard Lock: There are two causes for a hard lock:

1. Fourteen days have elapsed since the last brush-cleaning. The following screen will be displayed:

```
14 DAY TIMEOUT
CLEANING REQ'D
FREEZER LOCKED
PRESS SEL KEY
```

2. There has been a thermistor failure (freezing cylinder, hopper, or glycol) during the Heat Treatment process.

```
SYSTEM FAULT
SERVICE REQ'D
FREEZER LOCKED
PRESS SEL KEY
```

All four LEDs on the front of the freezer will light. Press the SEL key.

The next display is the screen that appears after the failure message. To comply with health codes, Heat Treatment system freezers **must** complete a Heat Treatment cycle daily and **must** also be brush-cleaned every 14-days. Brush-cleaning includes the normal disassembly and cleaning procedures. Failure to follow these guidelines will cause the control to lock the freezer out of the Auto mode. Press the WASH key.

**NO AUTO OPERATION
ALLOWED UNTIL
BRUSH CLEANING
PRESS WASH KEY**

The next display is the screen which will appear after the BRUSH CLEANING message and illustrates that the control is in the OFF mode and the machine needs to be disassembled and brush-cleaned.

**MODE: OFF

HOPPER TEMP: 45.0 F
FREEZER LOCKED**

Soft Lock: If a Heat Treatment cycle has not been initiated within the last 24 hours, all four LEDs on the front of the machine will light and a message will appear on the LCD. Line 3 of the LCD will indicate the reason the message appears. Following are the various messages that appear on line 3:

1. POWER SWITCH OFF: Power switch was in the OFF position.
2. MIX OUT PRESENT: There was a MIX OUT condition.
3. AUTO OR STANDBY OFF: The machine was not in the Auto or Standby mode.
4. NO HEAT CYCLE TRIED: A Heat Treatment cycle was not attempted in the last 24 hours. AUTO HEAT TIME was advanced, a power loss was experienced at the time the cycle was to occur, or there was a Heat cycle failure not due to a thermistor failure.)

**NO HEAT TREAT START
BECAUSE
VARIABLE MESSAGE
PRESS SEL KEY**

If the following screen appears, a soft lock has occurred during the Heat Treatment cycle:

**HEAT TREAT CYCLE
FAILURE
FREEZER LOCKED
PRESS SEL KEY**

If the temperature of the product has not fallen below 41°F (5°C) by the end of the Cool cycle, the following screen will appear:

**PRODUCT OVER TEMP
FREEZER LOCKED
PRESS SEL KEY**

Press the SEL key to advance to the next display.

When one of these messages appears, automatic freezer operation cannot take place until the freezer is disassembled and brush-cleaned or has completed a Heat Treatment cycle. The next display will instruct the operator to start a Heat Treatment cycle manually (by pressing the AUTO key) or to disassemble and brush-clean the freezer. If the AUTO key is pressed, the freezer will automatically start the Heat Treatment cycle and only the Heat cycle LED will light.

**NO AUTO OPERATION
ALLOWED. PRESS
AUTO FOR HEAT CYCLE
WASH TO BRUSH CLEAN**

If the WASH key is pressed, the next display will appear and the freezer will have to be disassembled and brush-cleaned.

Screen C is SET CLOCK. This screen will display the current date and time. The date and time may only be changed after the machine has been manually brush-cleaned but before it has been placed in the Auto mode. Move the cursor under the number you wish to change. Press the +++ key to increase the number, or the - - - key to decrease the number.

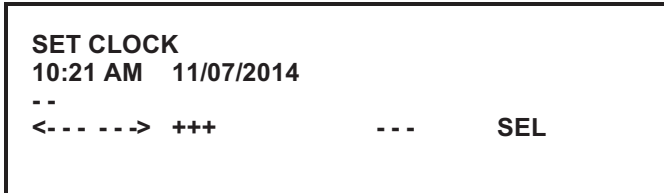

If an invalid date is entered, a second screen will appear. When the SEL key is pressed, the previous LCD screen will appear to allow correction of the entry. The controller will not advance to the DAYLIGHT SAVING TIME screen until a valid date is entered.

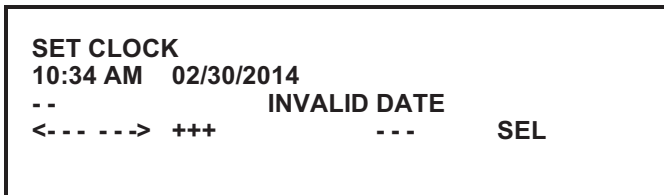

When a valid date is entered and SEL key is pressed, the DAYLIGHT SAVING TIME screen will display.

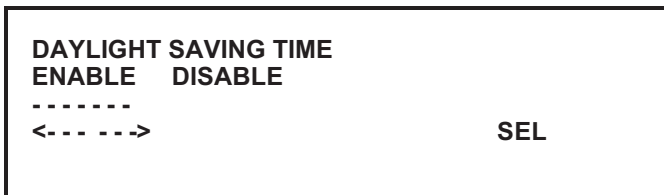

Pressing the arrow keys moves the cursor. Pressing the SEL key while under DISABLE accepts the selection and returns to the OPERATOR MENU.

Pressing the SEL key while under ENABLE accepts the selection and displays the following screen:

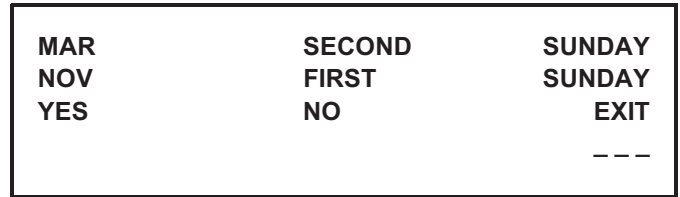

To change the default date, move the cursor to NO and press the SEL key. The following screen will display:

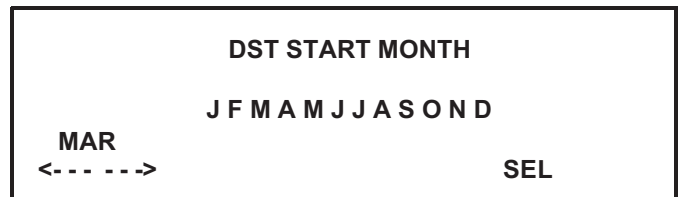

Use the arrow keys to select the desired month and press the SEL key. The following screen will display:



Use the arrow keys to select the desired month and press the SEL key. The following screen will display:



USER INTERFACE

Use the arrow keys to select the desired week and press the SEL key. The following screen will display:

DST END WEEK	
1 2 3 4 L	
FIRST SUNDAY <--- -->	SEL

Use the arrow keys to select the desired week and press the SEL key. The screen will return to the OPERATOR MENU.

Screen D is SYSTEM INFORMATION. The first screen indicates the software version used in the machine.

SOFTWARE VERSION PH61 CONTROL UVC2 VERSION XXX	SEL
---	------------

5

Pressing the SEL key a second time will display the Language screen.

Language V1.14roo	English 539	SEL
-----------------------------	-------------	------------

Pressing the SEL key a third time displays the bill of material (B.O.M.) number and serial number for the machine. Pressing the SEL key from this screen returns the display to the OPERATOR MENU.

B.O.M. S/N	PH6158FAGS K0000000	SEL
----------------------	------------------------	------------

Screen E is AUTO HEAT TIME. This screen is used to set the time of day in which the machine will automatically enter the Heat Treatment cycle. Pressing the arrow keys moves the cursor, pressing the plus or minus keys changes the selected digits, and pressing the SEL key accepts the settings and returns to the OPERATOR MENU.

AUTO HEAT TIME		
TIME: 12:00 AM		
--		
<--- -->	+++	--- SEL

Screen F is CURRENT CONDITIONS and SERVINGS COUNTER. The first screen displays the current viscosity of the product and the hopper and barrel temperatures. The last line of the display is the compressor countdown safety timer. The safety timer prevents the compressor from running more than 11 minutes (other than during the Cooling phase of the Heat Treatment cycle).

VISC 3800	HOPPER 38.5	BARREL 28.5
TIME C	11:00	11:00

Press the SEL key once to view the SERVINGS COUNTER screen. This screen indicates the number of times the draw switch has closed (number of draws) since the last brush-cleaning or since the last serving counter reset. Pressing the SEL key returns the screen to the OPERATOR MENU.

SERVINGS COUNTER DRAWS 12	SEL
--	------------

Note: Draws are counted during the Auto mode of operation only.

Screen G is HEAT CYCLE DATA. The information from the previous Heat Treatment cycles can be obtained through this screen. The most recent Heat Treatment cycle data will be shown first. Press the plus key to scroll through the remaining Heat cycle displays. If a Heat Treatment cycle failure should occur, a two-character message will appear on the second line of the screen. Press the SEL key to return to the OPERATOR MENU.

Listed below are the various messages which could appear:

- HT Heat time too long
- CL Cool time too long
- TT Failure in meeting total Heat Treatment cycle time requirement
- TH Failed thermistor probe
- ML MIX LOW condition
- MO MIX OUT condition
- BO Beater overload
- HO High-pressure cut-out
- PF Power failure

Note: If a power failure occurs but the Heat Treatment cycle does not fail, an asterisk (*) will appear on the third line of the display.

- OP Operator interruption
- PS Power switch in the OFF position
- RC Heat cycle record cleared

00/00	00:00	00:00		
HEAT	OVER	COOL	XX	
01:09	00:45	01:14		
TEMP AT END		38.5		1

Pressing the left arrow key on any HEAT CYCLE DATA screen will cause the extended data screen to be displayed. This screen shows the hopper, barrel, and glycol temperatures, and the amount of time the machine spent in the phases of the Heat cycle when the Heat cycle completed or was terminated.

HOPPER	BARREL	GLYCOL	
151.0	134.5	178.0	
PHASE TIME: 1:20			1

Pressing the SEL key returns the display to the OPERATOR MENU.

Screen H is the LOCKOUT HISTORY. This screen displays a history of the last 40 hard locks, soft locks, and brush-clean dates. Page numbers are indicated in the upper right-hand corner. Page 1 contains the most recent failure. Press the plus key to cycle through the pages.

The second line of the screen displays the date and time a failure occurred. The third line indicates the reason for a failure or will indicate that a successful brush-cleaning has occurred. Some failures occur for multiple reasons. When this happens, a page will be generated for each reason. Press the SEL key to return to the OPERATOR MENU.

LOCKOUT HISTORY			1
11/21/14	02:08		
SOFTLOCK ABORT			
+++		---	SEL

Screen I is the AUTO START TIME. This screen allows the operator to enable or disable AUTO START TIME. If enabled, the operator sets the time at which the machine will automatically enter Auto mode from Standby mode. The machine will only enter Auto mode under the following conditions: If the programmed Auto Start Time has been reached, the machine is in Standby, no soft lock or hard lock conditions exist, and the Auto Start Time feature has been enabled.

Use the arrow keys to move the cursor left or right. Use the plus and minus keys to change the time setting. Press the SEL key to save the selection and return to the OPERATOR MENU.

Screen J is the SERVICE MENU. This screen can only be accessed by a service technician.

Screen K is the STANDBY MODE. This option allows the operator to manually place the machine into Standby. Pressing the SEL key with the cursor under YES places the machine in Standby mode and returns to the OPERATOR MENU.

STANDBY MODE			
STANDBY	YES	NO	

<--- -->			SEL

Machine Setup

Evaluate the condition of lights and screen messages (HARD LOCK or SOFT LOCK, etc.) before performing opening procedures. If all four LEDs on the front of the machine are lit, the machine is locked. (See Figure 6-1.)

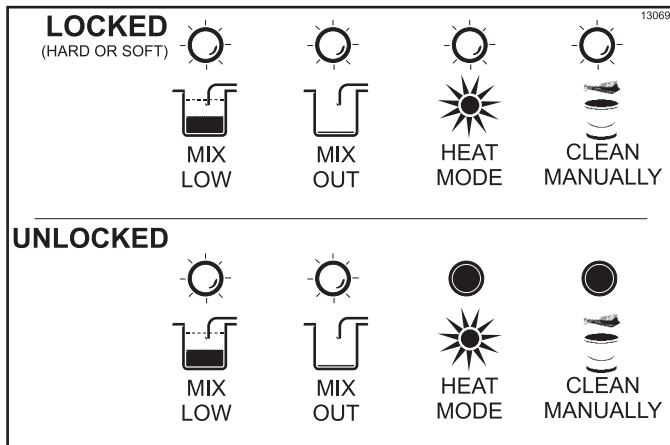

Figure 6-1

We begin our instructions at the point when we enter the store in the morning and find the parts disassembled and laid out to air-dry from the previous night's cleaning.

These opening procedures will show you how to assemble these parts into the freezer, sanitize them, and prime the freezer with fresh mix in preparation to serve your first portion.

If you are disassembling the machine for the first time or need information to get to the starting point in our instructions, turn to the Closing Procedures on page 6-17 and start there.

Freezing Cylinder Assembly



WARNING! Make sure the power switch is in the OFF position. Failure to follow this instruction may result in severe personal injury from hazardous moving parts.

With the parts tray available:

1. Before installing the shake beater driveshaft, lubricate the groove on the beater driveshaft. Slide the beater driveshaft boot seal over the small end of the beater driveshaft and engage into the groove on the shaft. Heavily lubricate the inside portion of the boot seal, and also lubricate the flat end of the boot seal that comes in contact with the rear shell bearing. Apply an even coat of lubricant to the shaft. **Do not** lubricate the square end. (See Figure 6-2.)

Note: When lubricating parts, use an approved food-grade lubricant (example: Taylor Lube HP).

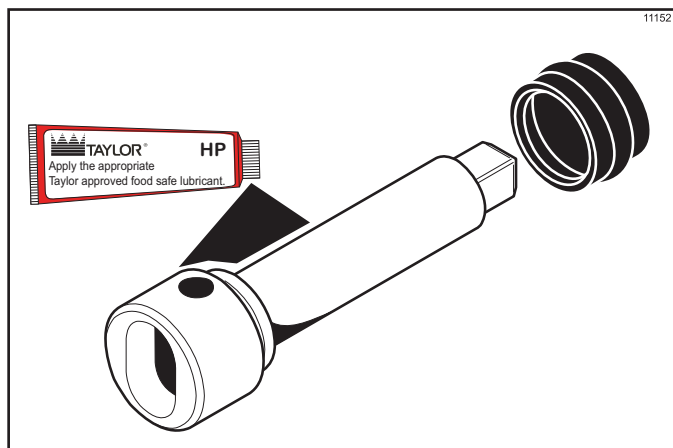

Figure 6-2

Note: To ensure that the mix does not leak out of the back of the freezing cylinder, the middle section of the boot seal should be convex or extend out from the seal. If the middle section of the boot seal is concave or extending into the middle of the seal, turn the seal inside out. (See Figure 6-3.)

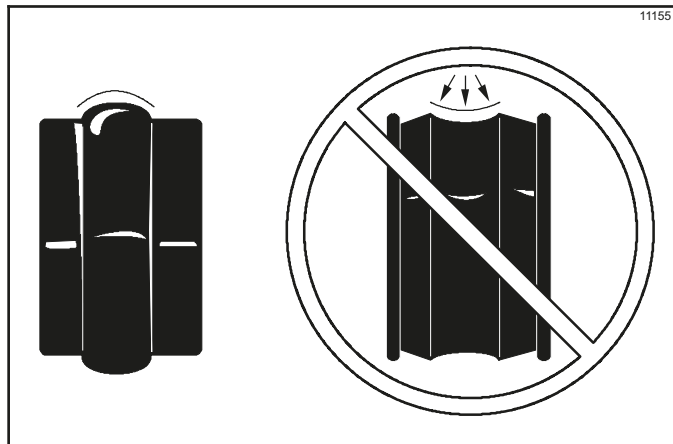

Figure 6-3

OPERATING PROCEDURES

2. Install the beater driveshaft through the rear shell bearing in the freezing cylinder and engage the square end firmly into the driveshaft coupling. Make sure the driveshaft fits into the drive coupling without binding. (See Figure 6-4.)

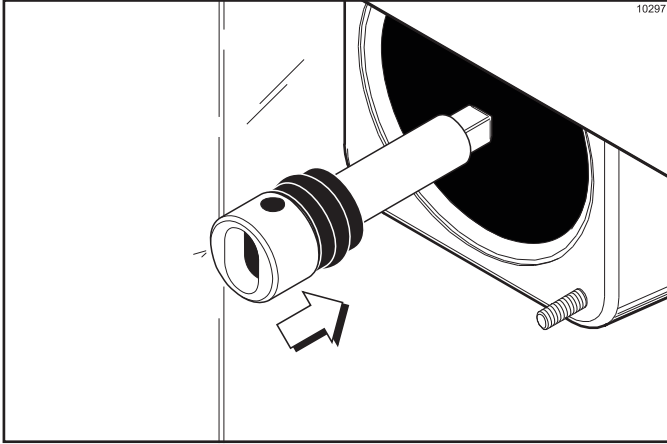

Figure 6-4

3. Check scraper blades for any nicks or signs of wear. If any nicks are present, replace the blades.

Note: *Scraper blades should be replaced every 6 months.*

4. If blades are in good condition, place each scraper blade over the holding pins on the beater assembly. (See Figure 6-5.)

6

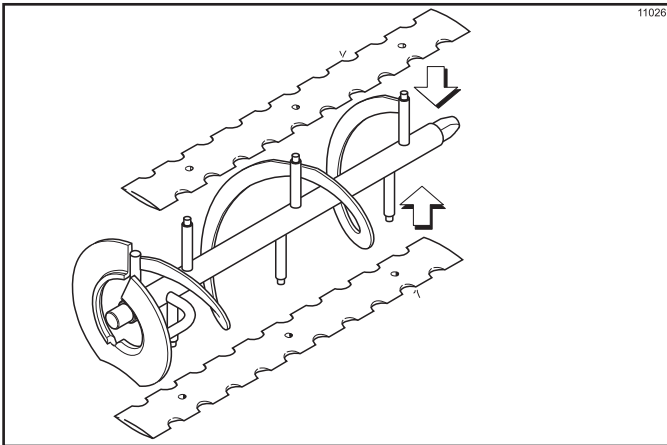

Figure 6-5

Note: *The holes in the scraper blade must fit over the pins to prevent damage.*

5. Hold the blades on the beater assembly. Insert the back of the beater assembly into the freezing cylinder and connect the drive hole with the driveshaft. (See Figure 6-6.)

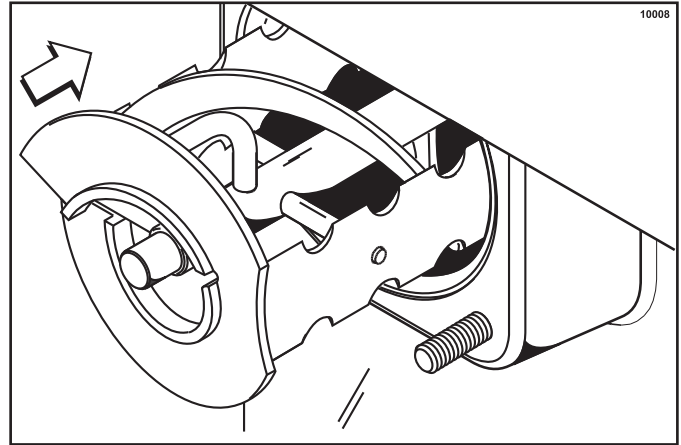

Figure 6-6

Note: *When properly seated, the beater will not protrude beyond the front of the freezing cylinder.*

6. Place the freezer door O-ring into the groove on the back of the freezer door. **Do not** lubricate the O-ring. Lubricate the outside diameter of the front bearing. Slide the front bearing into the door hub. (See Figure 6-7.)

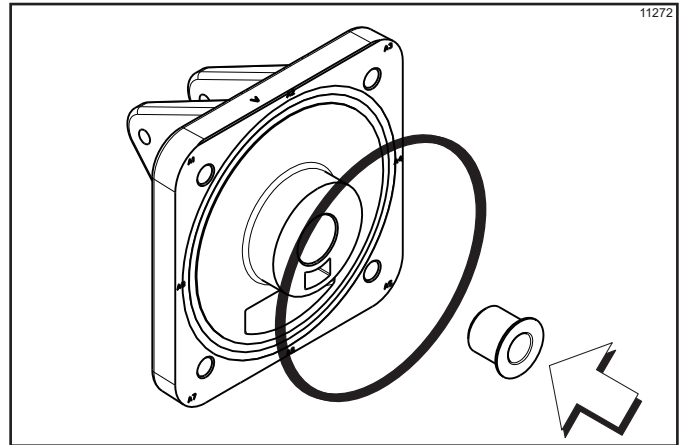

Figure 6-7

7. Install the freezer door. Position the freezer door on the four studs on the front of the freezing cylinder. Install the handscrews. Tighten equally in a crisscross pattern to ensure the door is snug. **Do not** overtighten. (See Figure 6-8.)

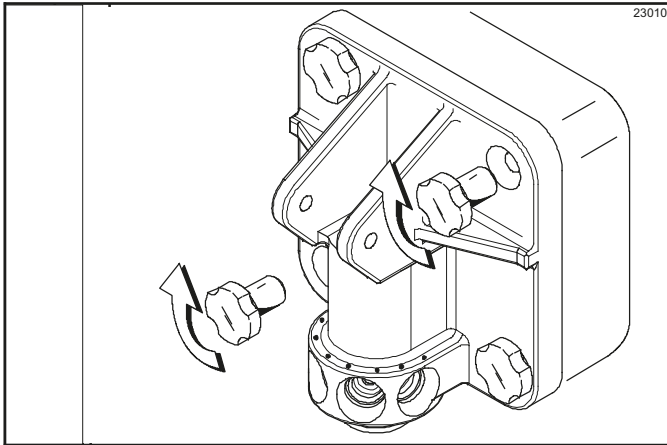

Figure 6-8

8. Assemble the draw-valve spinner assembly. Inspect draw-valve O-rings for cuts or nicks. (Replace if cut or nicked.) If draw-valve O-rings are in good condition, slide the two O-rings into the grooves of the draw valve and lubricate. (See Figure 6-9.)

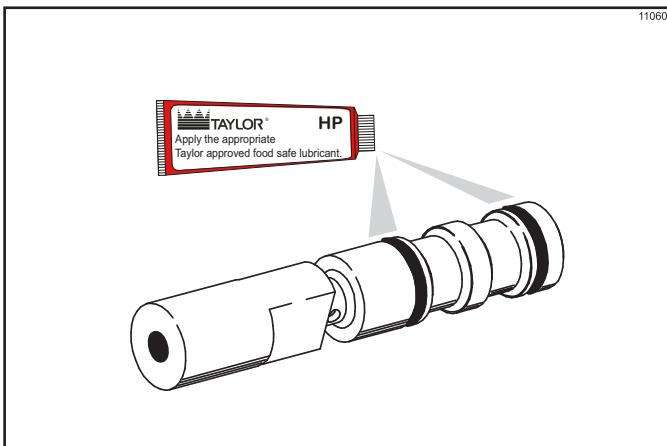

Figure 6-9

9. Lubricate the outer diameter of the spinner shaft seal. Fill the cups on each end of the seal with lubricant. Insert the spinner shaft seal into the bottom of the draw valve as far as it will go. The spinner shaft seal should fit into the seal groove inside the draw valve cavity.

Important! Inspect to see that the spinner shaft seal is correctly installed in the groove. A worn, missing, or improperly installed spinner shaft seal will cause product leakage out the top of the draw valve. (See Figure 6-10.)

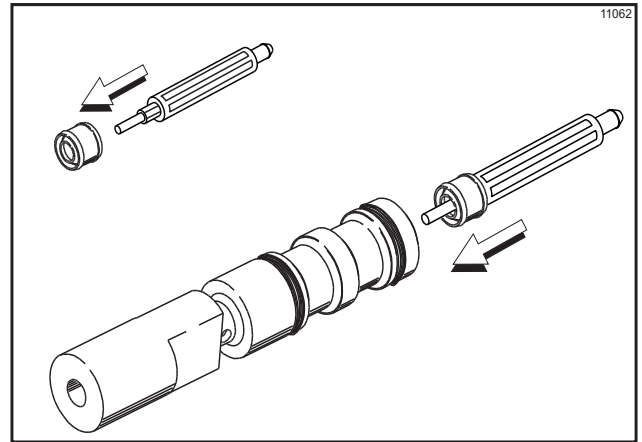

Figure 6-10

10. Lubricate the smaller end of the driven spinner. (See Figure 6-11.)

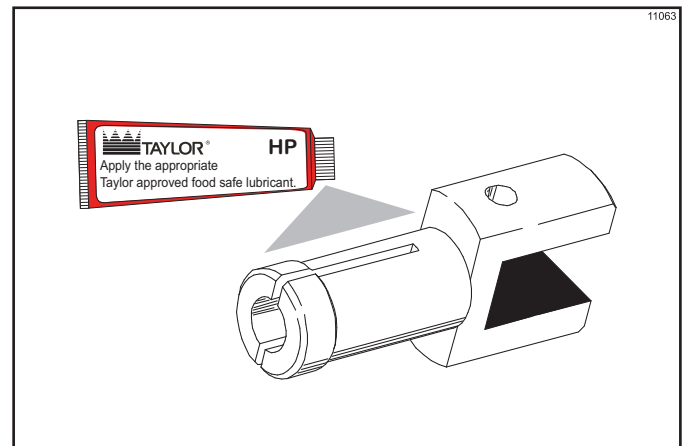

Figure 6-11

11. Squeezing the split end together, insert the driven spinner through the metal opening of the draw valve until it snaps into place. (See Figure 6-12.)

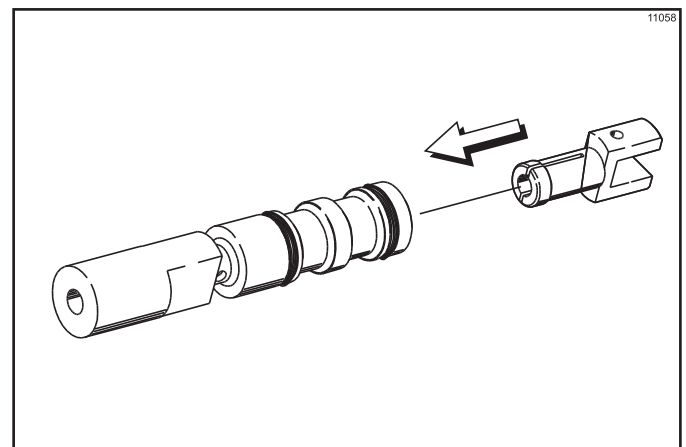

Figure 6-12

OPERATING PROCEDURES

12. Lubricate the inside of the freezer door spout, top and bottom. (See Figure 6-13.)

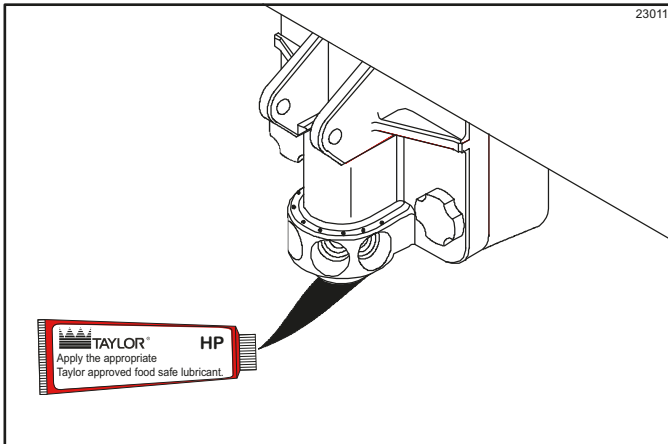

Figure 6-13

13. Insert the draw-valve spinner assembly from the bottom until the slot in the draw valve, which accepts the draw handle, comes into view. (See Figure 6-14.)

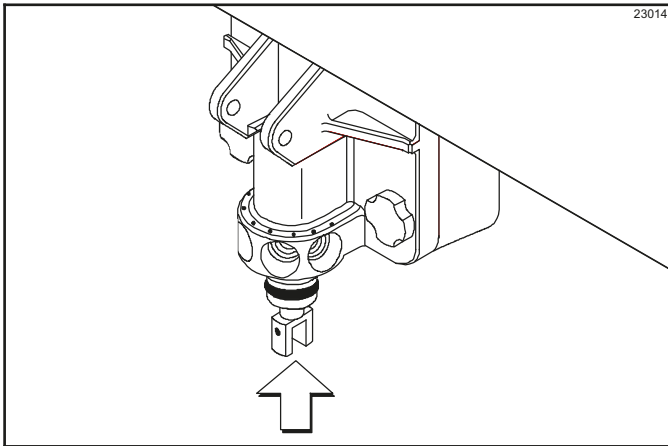

Figure 6-14

14. Install and lubricate the pivot pin O-ring. (See Figure 6-15.)

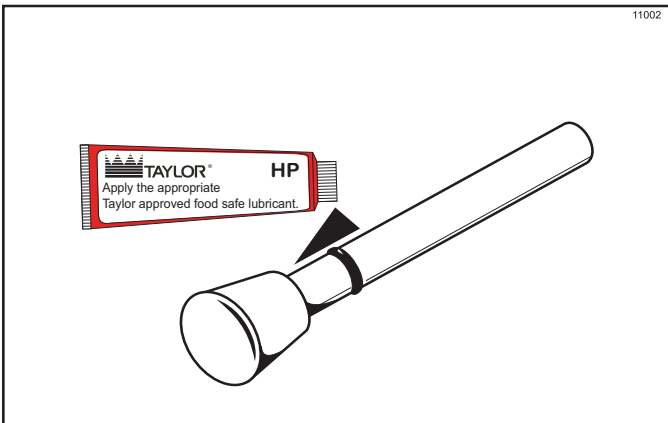

Figure 6-15

15. With the stopping tab of the draw handle facing down, slide the fork of the draw handle into the slot of the draw valve. Secure the draw handle with the pivot pin. (See Figure 6-16.)

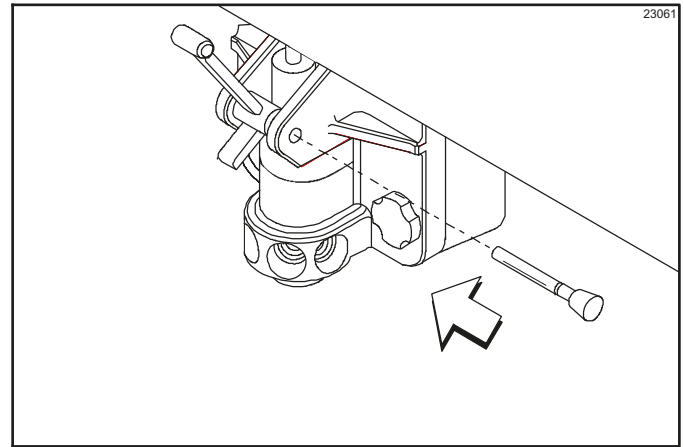

Figure 6-16

16. Lubricate the shaft of the spinner blade up to the groove. (See Figure 6-17.)

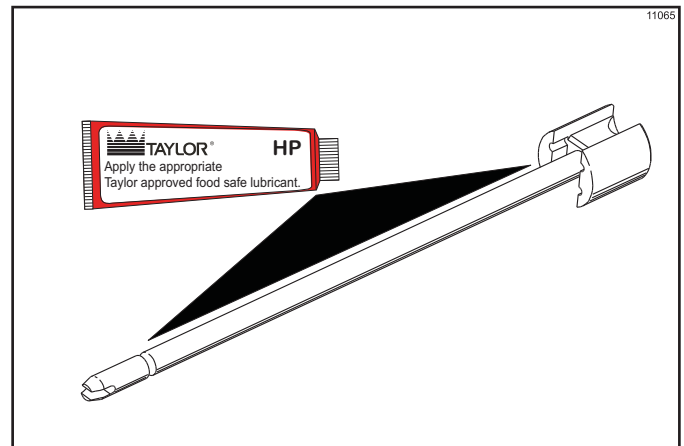

Figure 6-17

17. Insert the spinner blade shaft from the bottom, into the center of the driven spinner, and up through the draw valve cavity until the shaft appears at the top of the draw valve. The spinner blade must be aligned and engaged with the driven spinner at the bottom. This allows the spinner shaft to rise high enough to engage the spinner coupling at the top. (See Figure 6-18.)

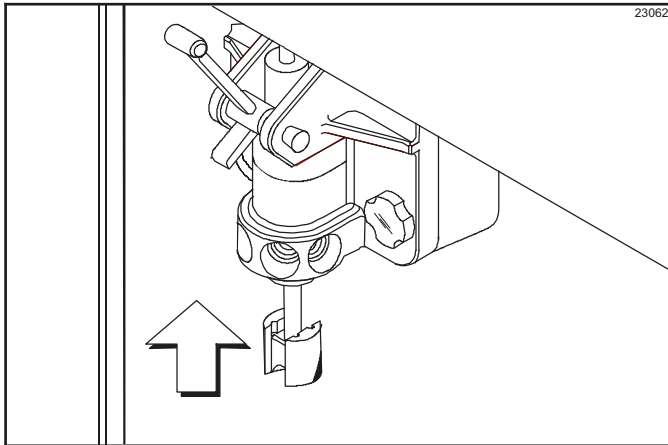

Figure 6-18

18. Raise the locking collar of the spinner coupling and insert the spinner shaft into the cavity of the coupling until the locking collar can drop into the locked position. (See Figure 6-19.)

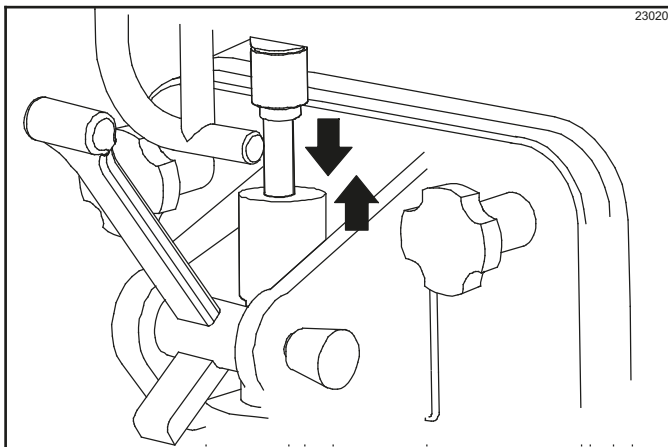

Figure 6-19

19. Snap the restrictor cap over the end of the door spout. (See Figure 6-20.)

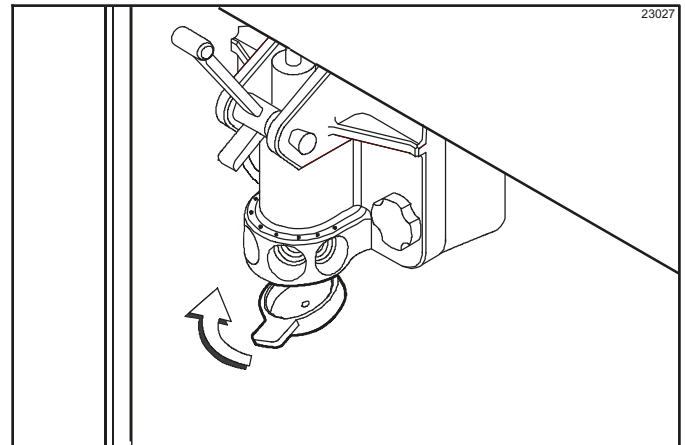

Figure 6-20

20. Insert the syrup-valve retainers and push them down. Install the syrup-valve pin retainer. (See Figure 6-21.)

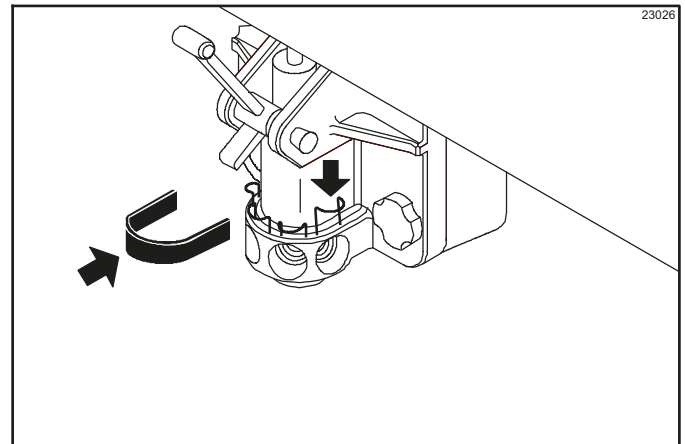

Figure 6-21

21. Slide the long drip pan into the hole in the front panel.
 22. Slide the short drip pan into the hole in the rear panel.
 23. Install the front drip tray and splash shield under the door spout. (See Figure 6-22.)

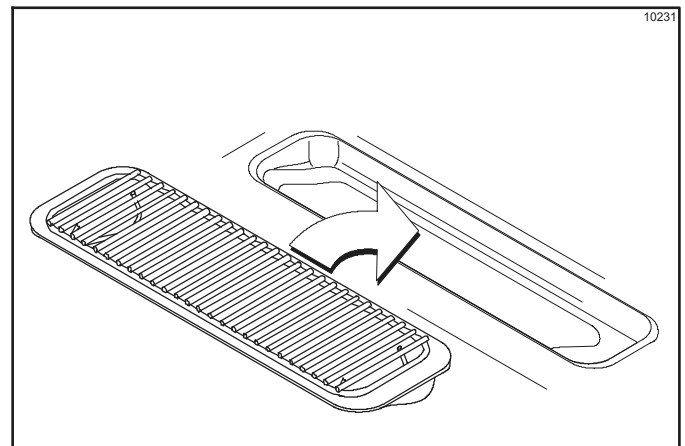

Figure 6-22

Mix Hopper Assembly

OPERATING PROCEDURES

With the parts trays available:

1. Inspect the rubber pump parts. The O-rings and gasket must be in 100% good condition for the pump and entire machine to operate properly. The O-rings and gasket cannot properly function if nicks, cuts, or holes in the material are present. Replace any defective parts immediately and discard the old.
2. Assemble the piston. Slide the red O-ring into the groove of the piston. **Do not** lubricate the O-ring. (See Figure 6-23.)

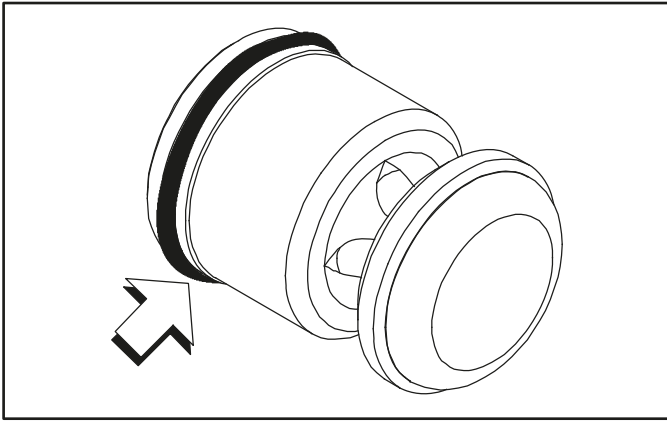

Figure 6-23

3. Apply a thin layer of lubricant to the inside of the pump cylinder at the retaining pin hole end. (See Figure 6-24.)

6

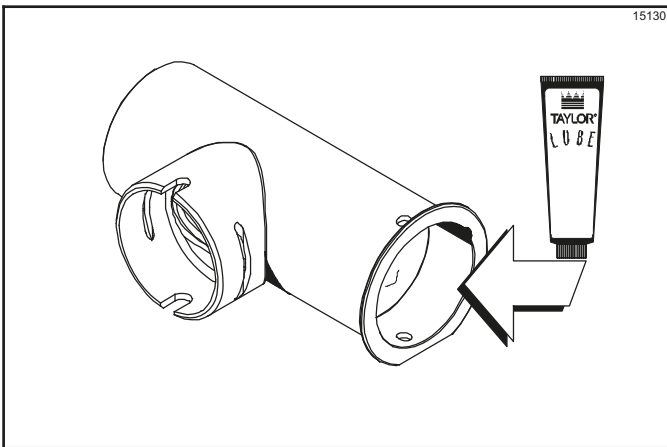

Figure 6-24

4. Insert the piston into the retaining pin hole end of the pump cylinder. (See Figure 6-25.)

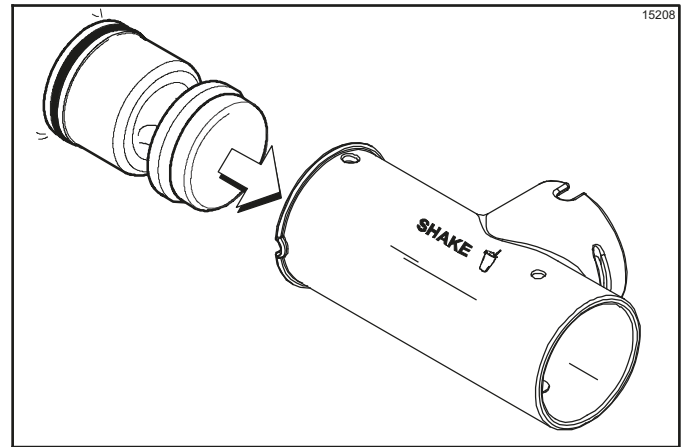

Figure 6-25

5. Assemble the valve cap. Slide the red O-ring into the groove of the valve cap. **Do not** lubricate the O-ring. (See Figure 6-26.)

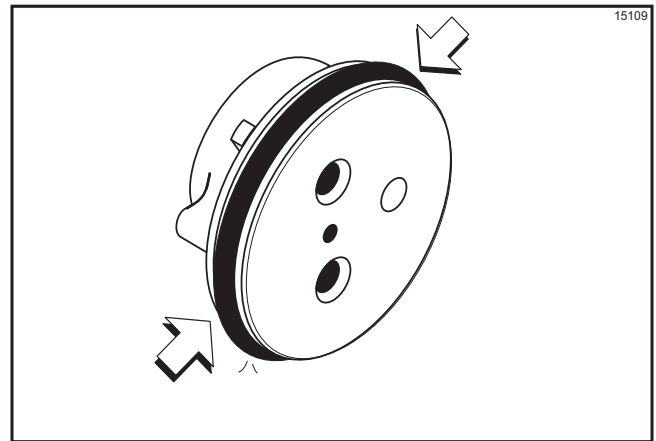

Figure 6-26

6. Slide the pump valve gasket into the holes on the cap. **Do not** lubricate the gasket. (See Figure 6-27.)

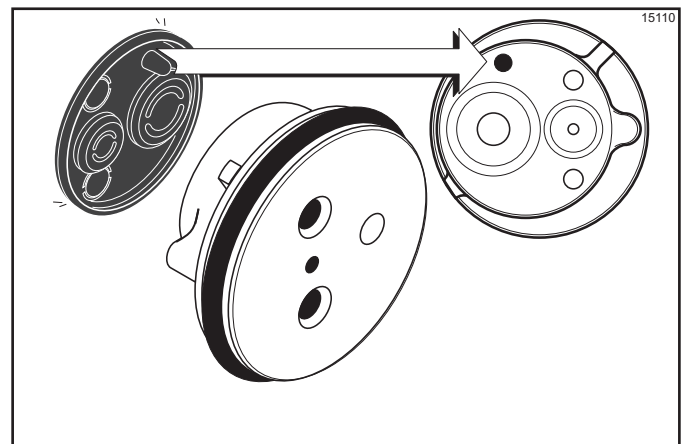

Figure 6-27

7. Insert the valve cap into the hole in the mix inlet adaptor. (See Figure 6-28.)

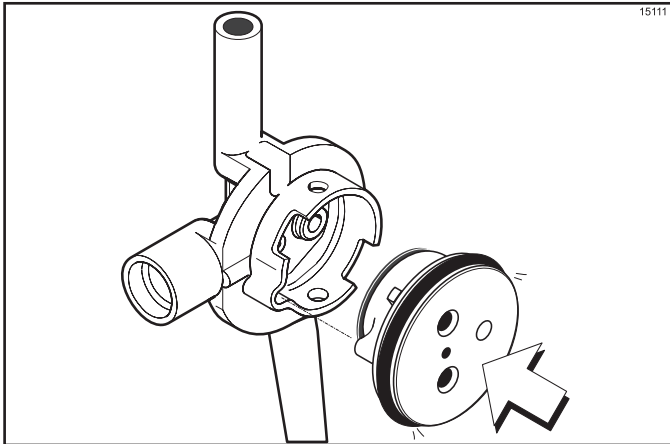

Figure 6-28

8. Insert the mix inlet assembly into the pump cylinder. (See Figure 6-29.)

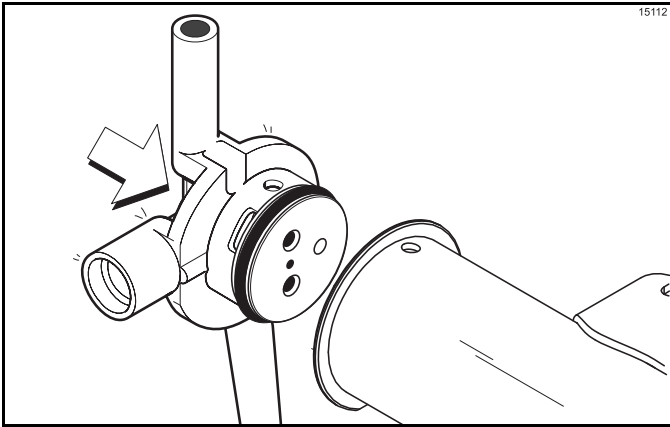

Figure 6-29

Note: The adaptor must be positioned into the notch at the end of the pump cylinder.

9. Secure the pump parts in position by sliding the retaining pin through the cross holes at one end of the pump cylinder. (See Figure 6-30.)

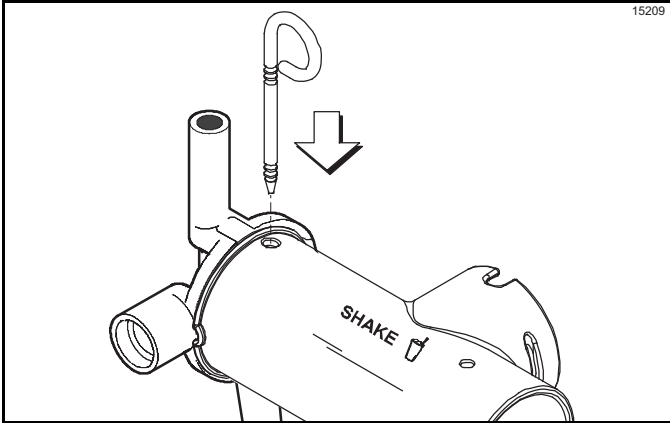

Figure 6-30

Note: The head of the retaining pin should be at the top of the pump when installed.

10. Assemble the feed tube assembly. Slide the check ring into the groove of the feed tube. (See Figure 6-31.)

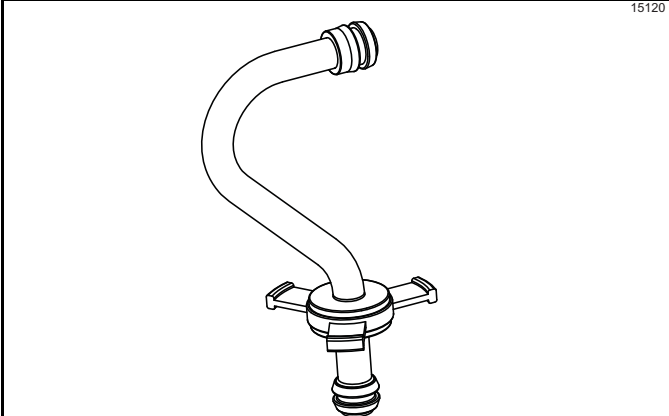

Figure 6-31

11. Install one red O-ring on each end of the mix feed tube and thoroughly lubricate. (See Figure 6-32.)

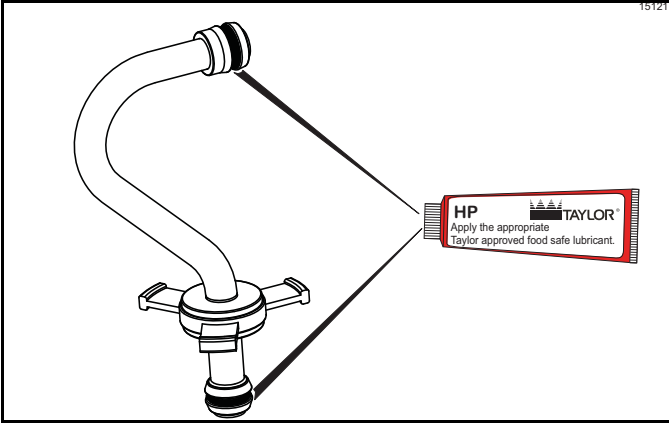

Figure 6-32

12. Lay the pump assembly, pump clip, feed tube, cotter pin, and agitator in the bottom of the mix hopper for sanitizing. (See Figure 6-33.)

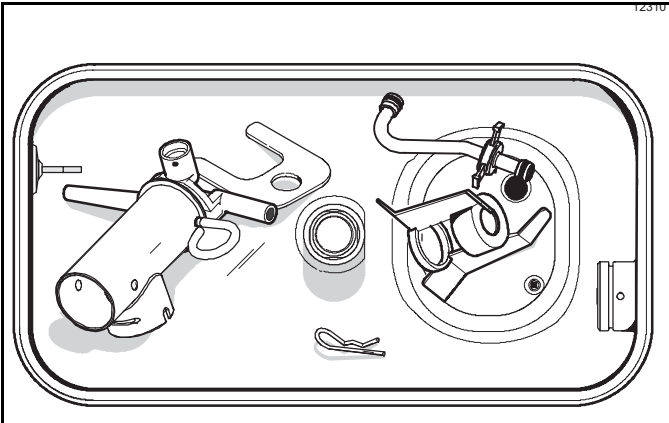

Figure 6-33

OPERATING PROCEDURES

- Slide the large black O-ring and the two smaller black O-rings into the grooves on the driveshaft. Thoroughly lubricate the O-rings and shaft. **Do not** lubricate the hex end of the shaft. (See Figure 6-34.)

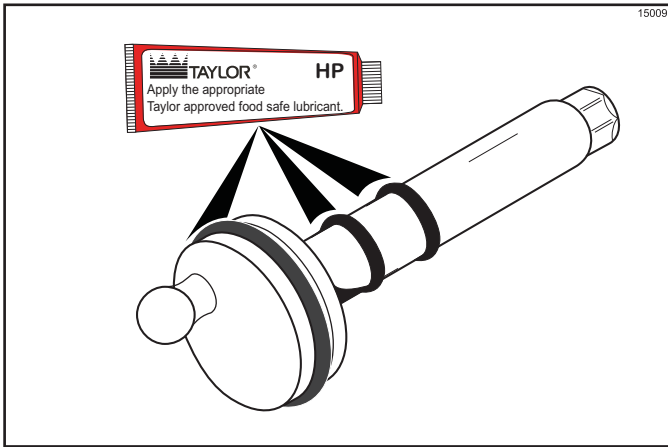

Figure 6-34

- Install the hex end of the driveshaft into the drive hub at the rear wall of the mix hopper. (See Figure 6-35.)

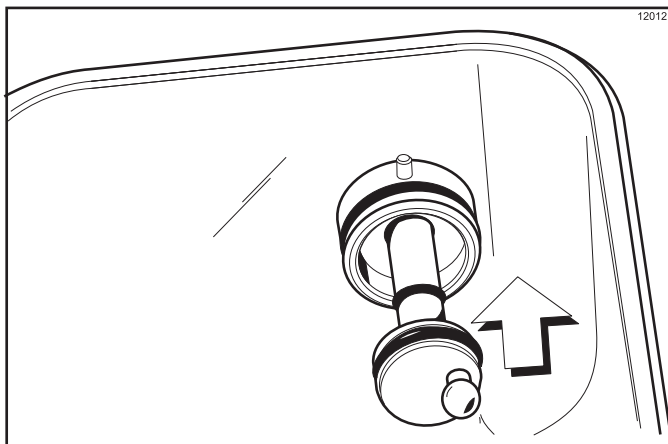

Figure 6-35

Note: For ease in installing the pump, put the ball crank of the driveshaft in the 3 o'clock position.

Sanitizing

- Prepare a 2.5 gal. (9.5 L) pail of cleaning/sanitizing solution with an active chlorine concentrate of 100 to 200 ppm (parts per million) approved for use by your company. Use warm water and follow the cleaning/sanitizing solution manufacturer's specifications.
- Pour the solution over all parts in the bottom of the mix hopper and allow it to flow into the freezing cylinder.

Note: You have just sanitized the mix hopper and parts. Therefore, make sure your hands are clean and sanitized before going on in these instructions.

- Using the white hopper brush, clean the mix-level sensing probes, mix hopper, mix inlet hole, outside of the agitator driveshaft housing, agitator, air/mix pump, pump clip, mix feed tube, and cotter pin.
- Install the air/mix pump assembly at the rear of the mix hopper. To position the pump on the drive hub, align the drive slot in the piston with the drive crank of the driveshaft. Secure the pump in place by slipping the pump clip over the collar of the pump, making sure the clip fits into the grooves in the collar. (See Figure 6-36.)

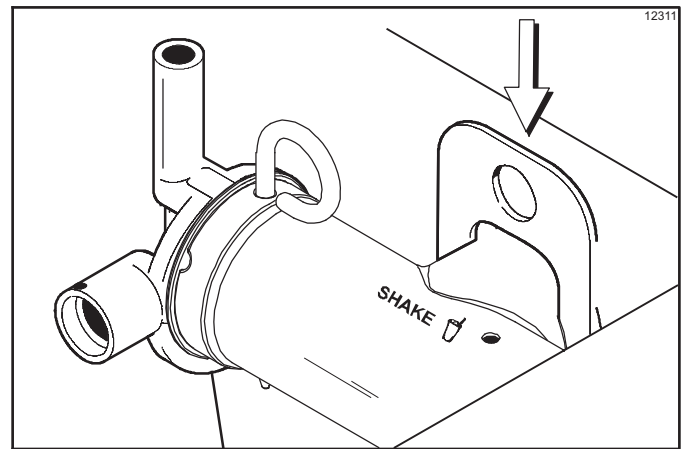

Figure 6-36

Important! Install the pump end of the mix feed tube and secure with the cotter pin. Failure to follow this instruction could result in sanitizer spraying on the operator.

- Prepare another 2.5 gal. (9.5 L) pail of the cleaning/sanitizing solution.
- Pour the solution into the mix hopper until it is within 1 in. (25 mm) of the top of the hopper.
- Using the white hopper brush, scrub the exposed sides of the hopper.
- Place the power switch in the ON position.

- Press the WASH key. This will cause the cleaning/sanitizing solution in the freezing cylinder to contact all areas of the freezing cylinder. Allow the solution to agitate for 5 minutes. (See Figure 6-37.)

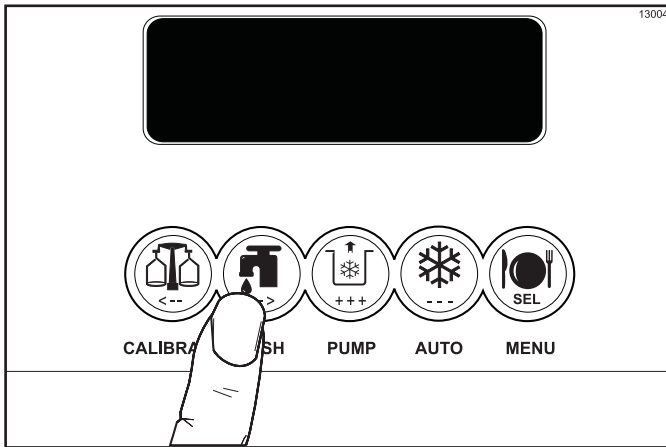

Figure 6-37

- With a pail beneath the door spout, open and close the draw valve six times.
- Press the PUMP key to sanitize the inside of the air/mix pump.
- Open the draw valve and draw off all the remaining cleaning/sanitizing solution.
- Press the WASH and PUMP keys to stop the Wash and Pump modes. Close the draw valve. (See Figure 6-38.)

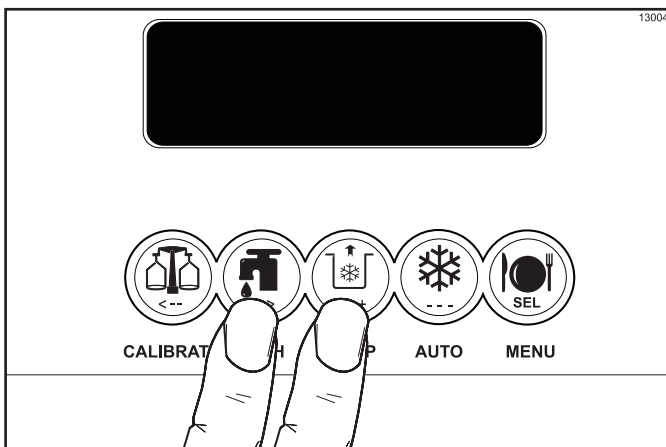

Figure 6-38

Important! Make sure your hands are clean and sanitized before going on in these instructions.

- Place the agitator on the agitator driveshaft housing. (See Figure 6-39.)

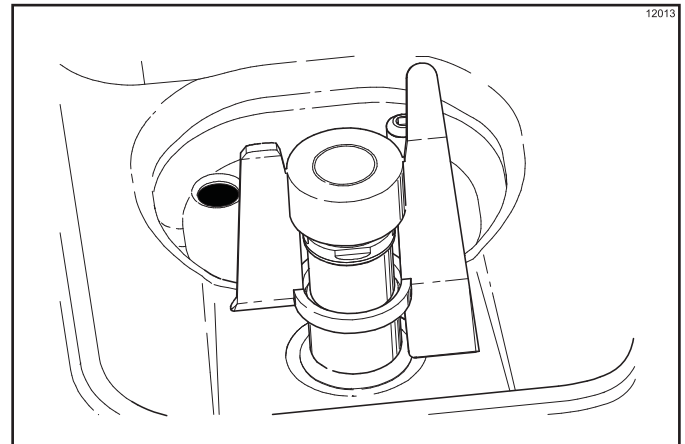

Figure 6-39

Note: If the agitator paddle should stop turning during normal operation, with sanitized hands, remove the agitator from the agitator driveshaft housing and brush-clean with sanitizing solution. Install the agitator back onto the agitator driveshaft housing.

- Remove the restrictor cap.
- Return to the machine with a small amount of sanitizing solution. With a pail below the door spout, dip the door-spout brush into the sanitizing solution and brush-clean the syrup ports in the freezer door, door spout, bottom of the driven spinner, spinner blade, and syrup line fittings. To ensure sanitary conditions are maintained, brush-clean each item for 60 seconds, repeatedly dipping the brush in sanitizing solution.
- With the syrup-port brush, brush each syrup-port hole 10 to 15 times. Dip the brush in sanitizing solution before brushing each port.
- Fill the squeeze bottle with cleaning/sanitizing solution. With a pail beneath the door, insert the tube end of the squeeze bottle into the syrup port and squeeze the bottle firmly. This action will force solution out of the adjacent port and down around the spinner. This procedure should be performed for at least 10 seconds per port.
- Install the syrup valves and the restrictor cap.

Priming

Note: Evaluate the condition of LEDs (lights) and screen messages before performing priming procedures. If all four LEDs are flashing, the machine is locked.

1. With a mix pail beneath the door spout, open the draw valve. Pour 2-1/2 gal. (9.5 L) of fresh mix into the mix hopper and allow it to flow into the freezing cylinder. This will force out any remaining cleaning/sanitizing solution. When only mix is flowing from the door spout, close the draw valve.
2. When mix stops bubbling down into the freezing cylinder, remove the cotter pin from the outlet fitting of the mix pump. Remove the mix feed tube. Insert the outlet end of the mix feed tube into the mix inlet hole in the mix hopper. Place the inlet end of the mix feed tube into the outlet fitting of the mix pump. Secure with the cotter pin. (See Figure 6-40.)

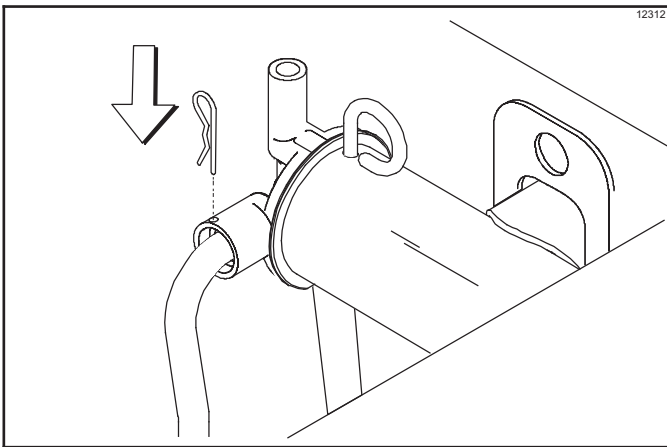

Figure 6-40

3. Install the shake cup holder. (See Figure 6-41.)

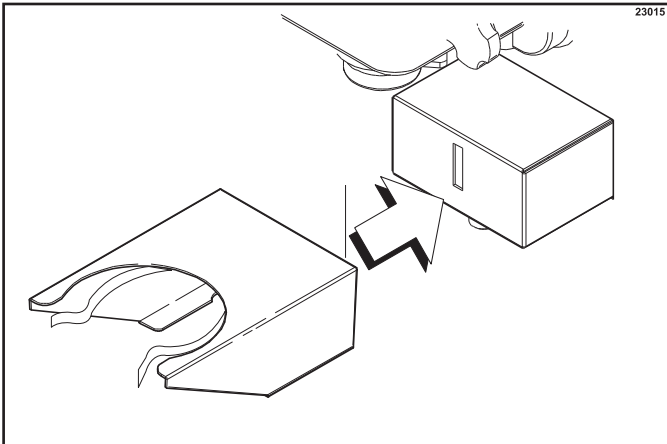

Figure 6-41

4. Press the AUTO key. (See Figure 6-42.)

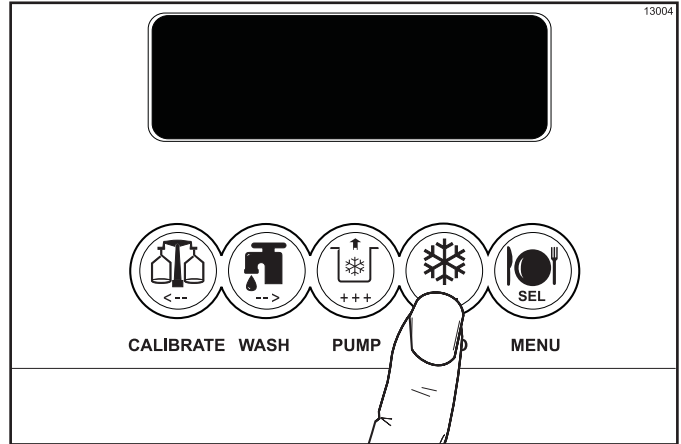

Figure 6-42

5. Fill the hopper with fresh mix and place the mix hopper cover in position.

Use only **fresh** mix when priming the freezer.

Important! When drawing product, allow the draw handle to close automatically. Manually closing the draw handle will damage the syrup valve and cause serious syrup flavor carryover.

Daily Closing Procedures

This procedure must be done at the close of business.

Important! The level of mix in the mix hopper must be above the Mix Low probe. (The MIX LOW light must not be ON.)

Note: If the CLEAN MANUALLY light is flashing, **do not** add mix. The machine must be disassembled and brush-cleaned within 24 hours.

The machine must be in the Auto or Standby mode before the Heat cycle may be started. (See Figure 6-43.)

MODE:	AUTO
MIX:	OK
HOPPER	40.0F
BRUSH CLEAN ON:	MM/DD

Figure 6-43

1. Prepare the three-compartment sink for washing, rinsing, and sanitizing. Fill the first sink with an approved cleaning solution, the second sink with cool, clean water, and the third sink with a cleaning/sanitizing solution with an active chlorine concentrate of 100 ppm to 200 ppm. Use warm water and follow the cleaning/sanitizing solution manufacturer's specifications.
2. Remove the hopper cover, shake cup holder, front drip tray, splash shield, and all three drip pans (two from the rear panel and one from the front panel).

Important! Make sure your hands are clean and sanitized before performing these next steps.

Note: Pressing the CAL key will stop agitator movement for 10 seconds. The agitator will automatically restart after 10 seconds.

3. Remove the agitator from the mix hopper, and the restrictor cap from the freezer door spout.
4. Take the agitator, hopper cover, shake cup holder, drip pans, front drip tray, splash shield, restrictor cap, syrup-hole plugs, spout cap, and spout cap O-ring to the three-compartment sink.
5. Wash, rinse, and sanitize the parts in the three-compartment sink. If required by your local code, rinse with clean water after sanitizing.
6. Place the restrictor cap, front drip tray, shake cup holder, and splash shield on a clean, dry surface to air-dry overnight or until the Heating cycle is complete.
7. Install the agitator back onto the agitator driveshaft housing. Replace the hopper cover. (See Figure 6-44.)

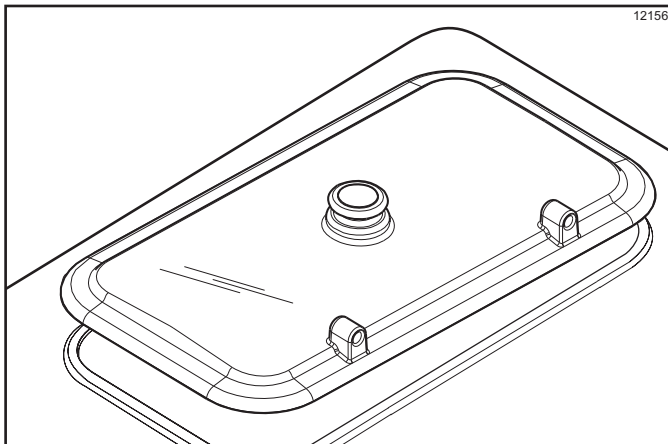

Figure 6-44

Important! If you do not install the agitator correctly, the machine will fail the Heat cycle and will lock out in the morning.

8. Remove the syrup lines from the freezer door.
9. Return to the machine with a small amount of cleaning/sanitizing solution. With a pail below the door spout, dip the door-spout brush into the cleaning solution. Brush-clean the syrup ports in the freezer door, door spout, bottom of the driven spinner, spinner blade, and syrup line fittings. (See Figure 6-45.)

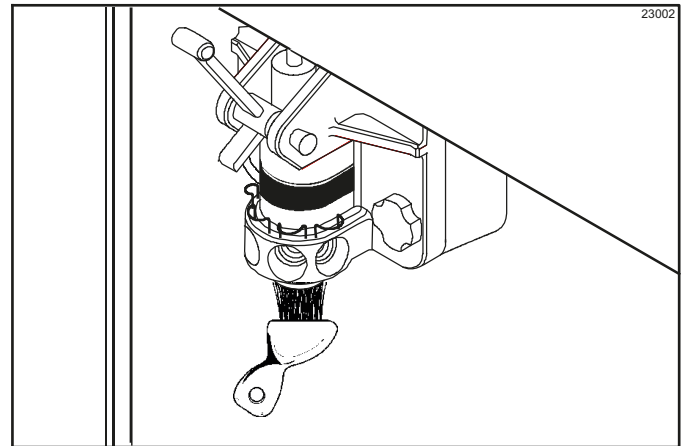

Figure 6-45

Note: To ensure sanitary conditions are maintained, brush each item for 60 seconds, repeatedly dipping the brush in cleaning solution.

10. With the syrup-port brush, brush each syrup-port hole 10 to 15 times. Dip the brush in the cleaning solution before brushing each port. (See Figure 6-46.)

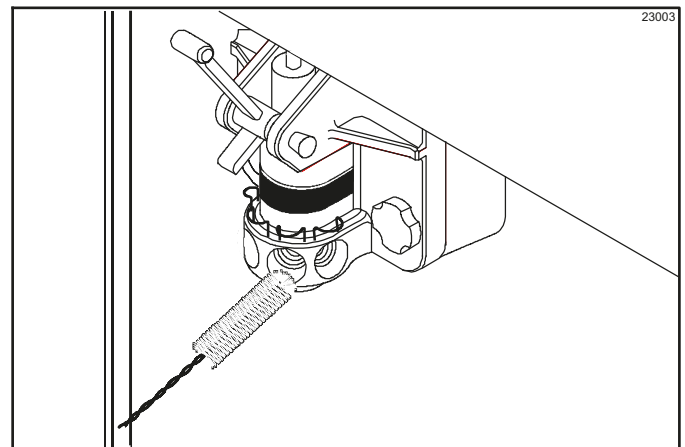

Figure 6-46

OPERATING PROCEDURES

11. With sanitized hands, remove the syrup valve pin retainer and the syrup valve retainers. Brush-clean the empty orifices. Replace the syrup valve retainers and install the syrup valve pin retainer.
12. Fill the squeeze bottle with cleaning/sanitizing solution. With a pail beneath the door, insert the tube end of the squeeze bottle into the syrup valve retainer holes and the syrup port. Squeeze the bottle firmly. This action will force solution out of the adjacent port and down around the spinner. This procedure should be performed for at least 10 seconds per port. (See Figure 6-47.)

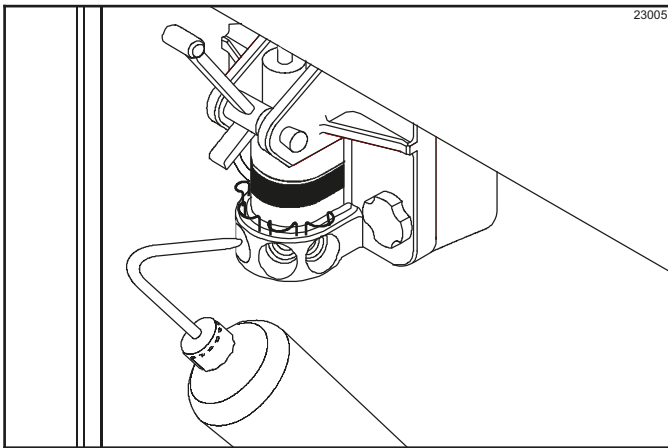

Figure 6-47

- 6**
13. Place the spout cap O-ring in the spout cap. Fill the spout cap with the cleaning/sanitizing solution. While holding the draw valve closed, install the spout cap over the end of the door spout. This will cause the solution to backflow through the syrup ports. (See Figure 6-48.)

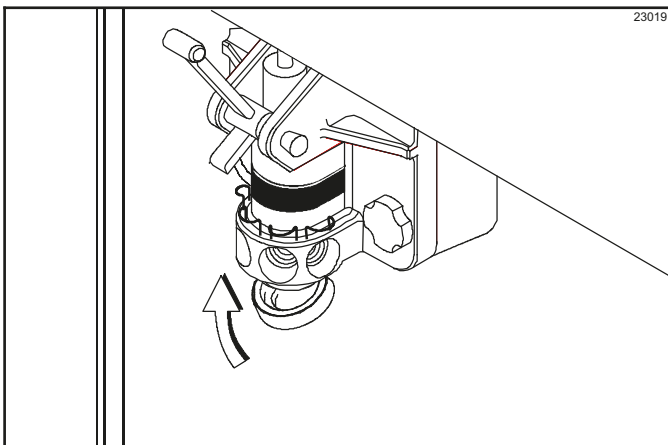

Figure 6-48

14. Install the syrup-hole plugs in the syrup ports in the freezer door. (See Figure 6-49.)

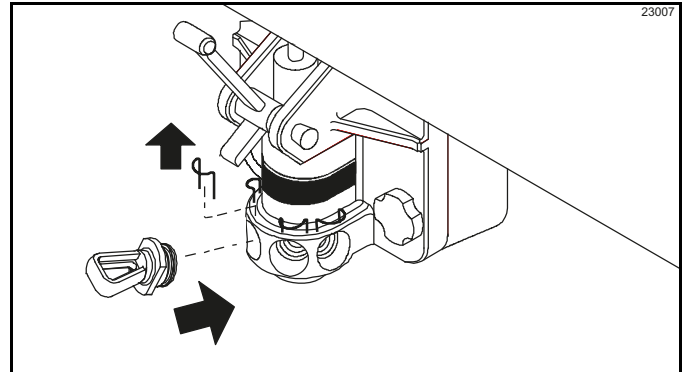

Figure 6-49

15. Remove, clean, and re-install the long drip pan through the front panel.
16. Install the short drip pan in the rear panel.
17. Use a clean, sanitized towel to wipe down the freezer door and area around the bottom of the freezer door. The Heat cycle will start when the clock on the machine reaches the AUTO HEAT TIME set in the OPERATOR MENU (see page 5-8).

There are three phases of the Heat cycle: Heat, Hold, and Cool. Each phase has a time limit. If any one of the three phases fails to reach the proper temperatures within the time limit, the cycle will automatically abort and return to the Standby mode. The LCD will display the message: HEAT TREAT CYCLE FAILURE - FREEZER LOCKED - PRESS SEL KEY. The product may not be safe to serve. The machine will be locked out (soft lock) of the Auto mode. The operator will be given the option of pressing the AUTO key, which will begin a new Heat cycle, or pressing the WASH key, which will place the machine in the OFF mode to allow a brush-cleaning of the machine.

Note: Once the Heat cycle has started, it cannot be interrupted. The Heat cycle will take a maximum of 4 hours to complete with a full hopper.



WARNING! DO NOT attempt to draw product or disassemble the machine during the Heat Treatment cycle (if equipped). The product is hot and under extreme pressure. Severe burns from hot product may result if this instruction is not followed.

When the Heat cycle is complete, the control will return to the Standby mode.

Daily Opening Procedures

Evaluate the condition of LEDs (lights) and screen messages (HARD LOCK or SOFT LOCK, etc.) before performing opening procedures. As indicated in the illustration below, four flashing LEDs, indicates a LOCKED condition. (See Figure 6-50.)

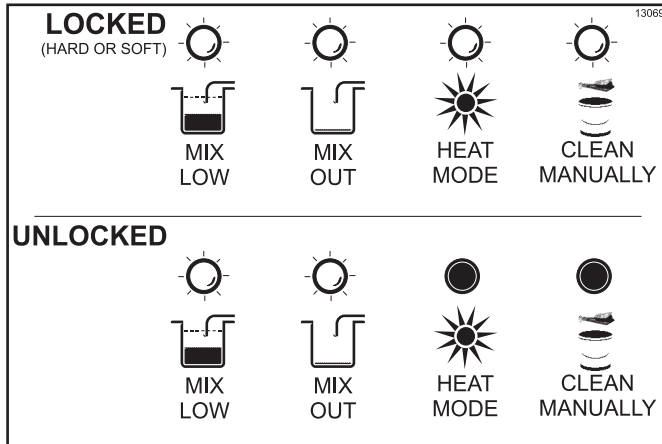

Figure 6-50

Setup—Complete the Following

Important! Make sure your hands are clean and sanitized before performing these following steps.

1. When the Heat cycle is complete, the normal display will show the machine in the Standby mode.
2. Prepare a small amount of a cleaning/sanitizing solution with an active chlorine concentrate of 100 to 200 ppm. Use warm water and follow the cleaning/sanitizing solution manufacturer's specifications.
3. Remove the syrup-hole plugs and spout cap with O-ring from the freezer door.
4. Sanitize the restrictor cap, syrup-hole plugs, spout cap, O-ring, shake cup holder, front drip tray, and splash shield in the cleaning/sanitizing solution.

5. Return to the machine with a small amount of cleaning/sanitizing solution. With a pail below the door spout, dip the door-spout brush in the solution. Brush-clean the syrup ports in the freezer door, door spout, bottom of the driven spinner, spinner blade, and syrup line fittings. (See Figure 6-51.)

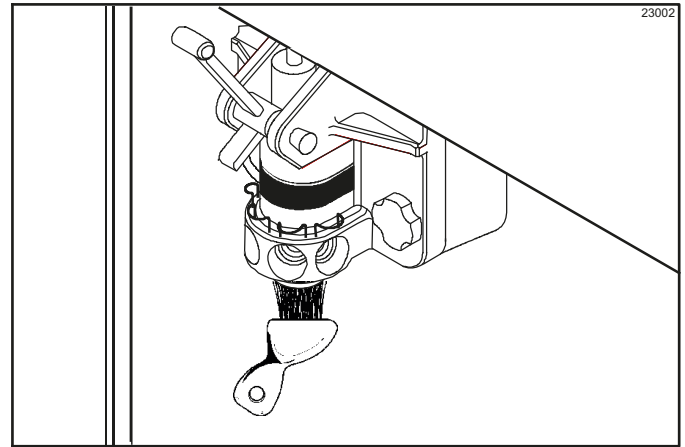

Figure 6-51

Note: To ensure sanitary conditions are maintained, brush-clean each item for 60 seconds, repeatedly dipping the brush in cleaning/sanitizing solution.

6. With the syrup-port brush, brush each syrup-port hole 10 to 15 times. Dip the brush in solution before brushing each port. (See Figure 6-52.)

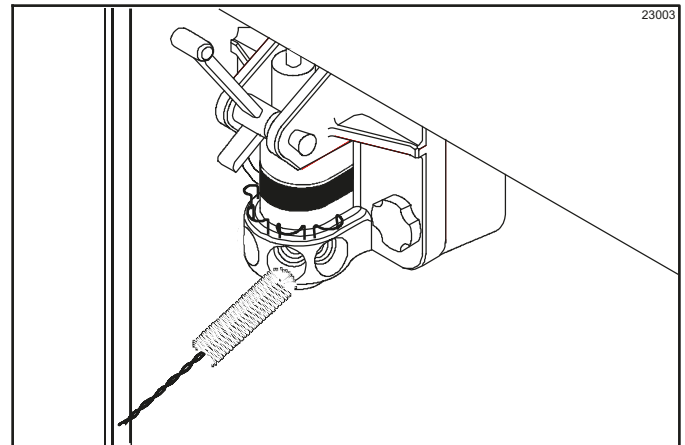

Figure 6-52

OPERATING PROCEDURES

7. Fill the squeeze bottle with cleaning/sanitizing solution. With a pail beneath the door, insert the tube end of the squeeze bottle into the syrup port. Squeeze the bottle firmly. This will force solution out of the adjacent port and down around the spinner. This procedure should be performed for at least 10 seconds per port. (See Figure 6-53.)

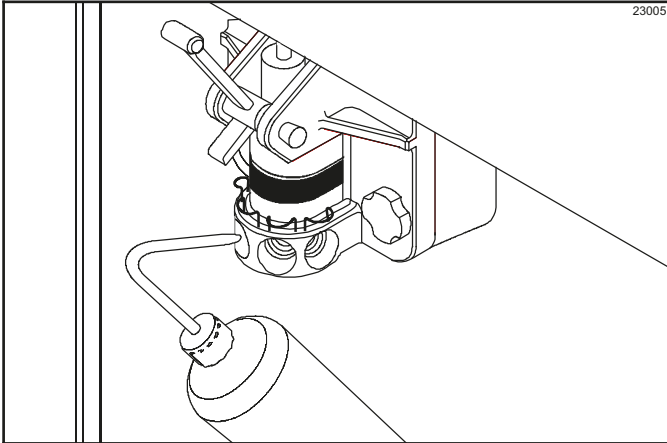

Figure 6-53

8. Install the restrictor cap on the freezer door spout. (See Figure 6-54.)

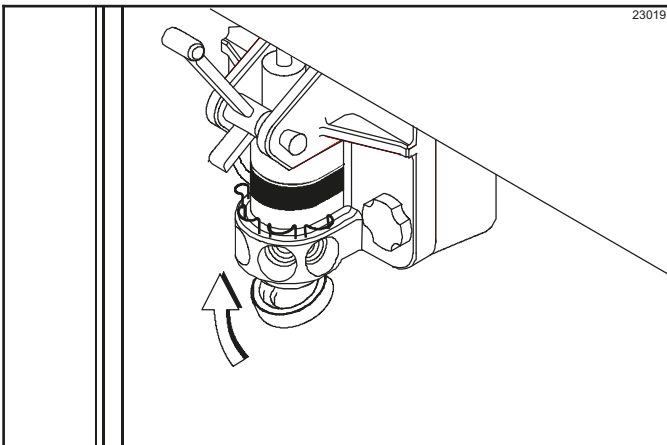

Figure 6-54

9. Use a clean, sanitized towel to wipe down the freezer door and area around the bottom of the freezer door.
10. Install the shake cup holder.

11. Raise a syrup valve retainer. Install the syrup valve. Push the syrup valve retainer down to hold the valve in place. Repeat this procedure for each syrup valve. (See Figure 6-55.)

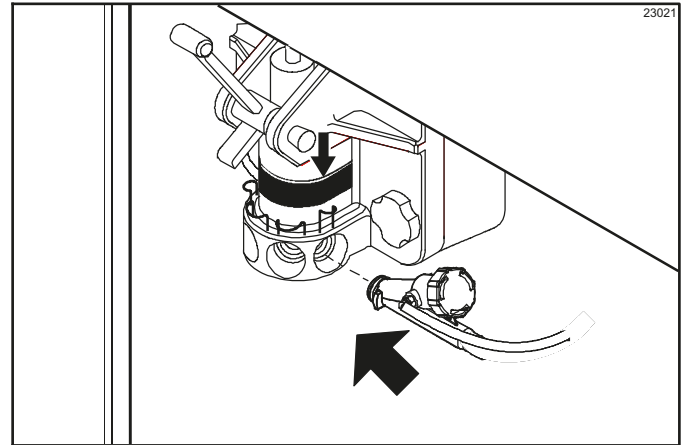

Figure 6-55

12. When ready to resume normal operation, press the AUTO key. (See Figure 6-56.)

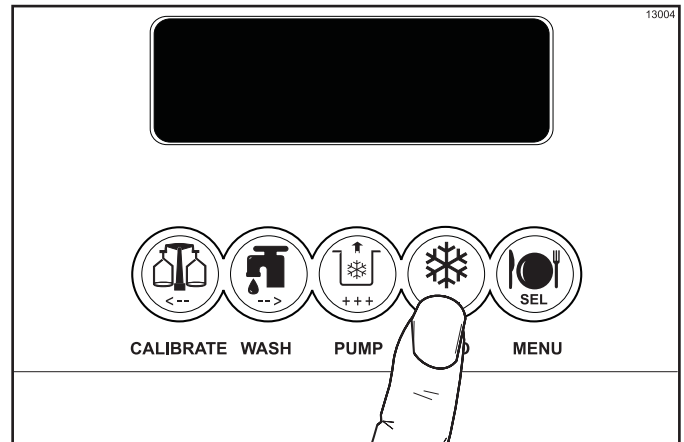

Figure 6-56

Note: This step should be performed approximately 15 minutes prior to serving product.

Syrup Calibration and Priming

Syrup Calibration

Calibrating the syrup flow should be performed weekly when the syrup system is cleaned. It is vital that the correct amount of syrup be incorporated into the mix to obtain a quality shake. To determine the rate of syrup flow, you will need a calibration cup indicating fluid ounces.

If thin syrup is being used, the proper rate of syrup flow is 1 oz. (30 ml) of syrup in 5 seconds. If thick syrup is being used, the proper rate of syrup flow is 1 oz. (30 ml) of syrup in 7 seconds.

Once this rate is set, the correct amount of syrup will be blended with the shake base regardless of the size of shake served. Please note that syrup calibration is critical when changing the promotional fourth flavor syrup. (See Figure 6-57.)

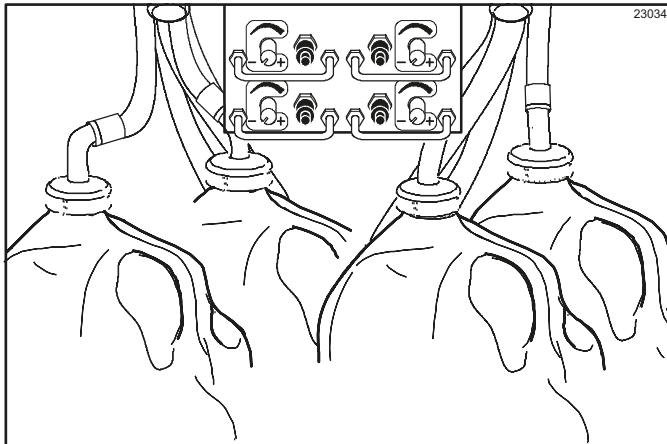

Figure 6-57

Calibration Procedure

1. Disconnect the syrup valve from the freezer door. Raise the syrup valve retainer and pull the valve straight out. (See Figure 6-58.)

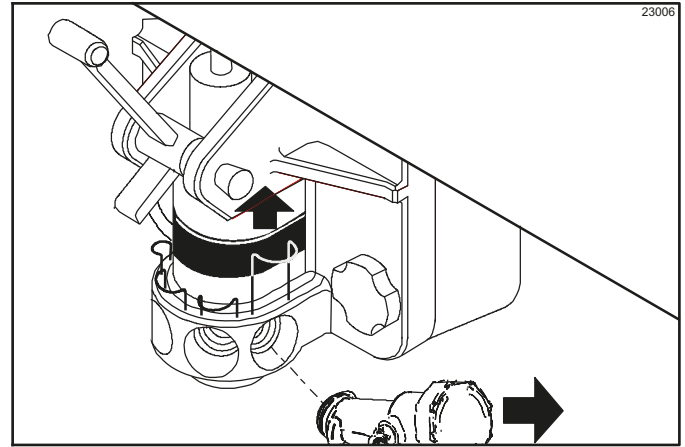

Figure 6-58

2. Hold an empty cup under the syrup valve. (See Figure 6-59.)

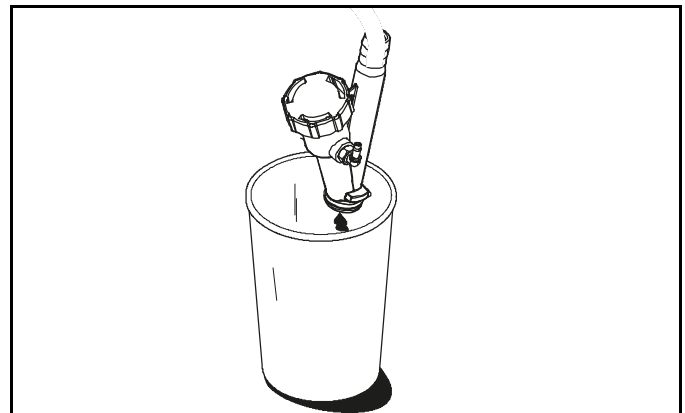

Figure 6-59

3. Push the corresponding syrup flavor key. The light should be illuminated. (See Figure 6-60.)

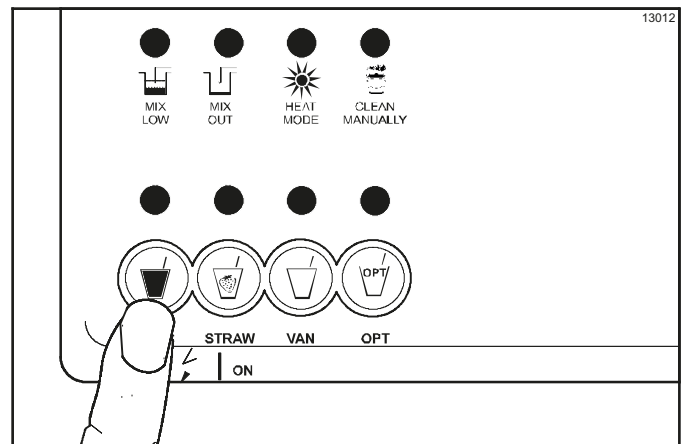

Figure 6-60

OPERATING PROCEDURES

- Press the CAL (calibrate) key. A message will appear on the LCD. Press the WASH key to start the pump and to prime the syrup line. When a steady stream of syrup is flowing into the cup, press the CAL key again to stop the pump.
- Hold the small portion of the syrup calibration cup under the syrup valve. (See Figure 6-61.)

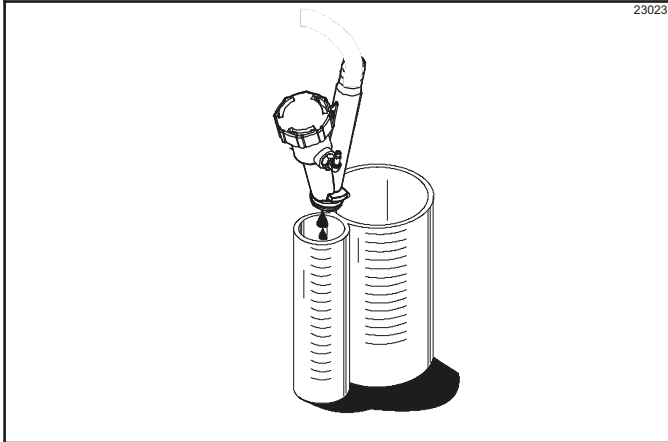

Figure 6-61

- Press the CAL key. A message will appear on the LCD.
- For machines using thin syrup:** Press the AUTO key to start the pump and dispense syrup for 5 seconds. **For machines using thick syrup:** Press the AUTO key to start the pump and dispense syrup for 7 seconds.
- The pump will automatically stop. If the amount of syrup delivered is 1 oz. (30 ml), the syrup pump is properly calibrated.
- If less than 1 oz. (30 ml) of syrup was delivered, turn the corresponding syrup adjustment knob clockwise to increase the syrup flow.
If more than 1 oz. (30 ml) of syrup was delivered, turn the corresponding syrup adjustment knob counterclockwise to decrease the syrup flow.

Note: The adjustment is very sensitive.

The syrup adjustment knobs are mounted at the top of the syrup cabinet in the same order as the syrup containers (chocolate, strawberry, vanilla and the fourth flavor). (See Figure 6-62.)

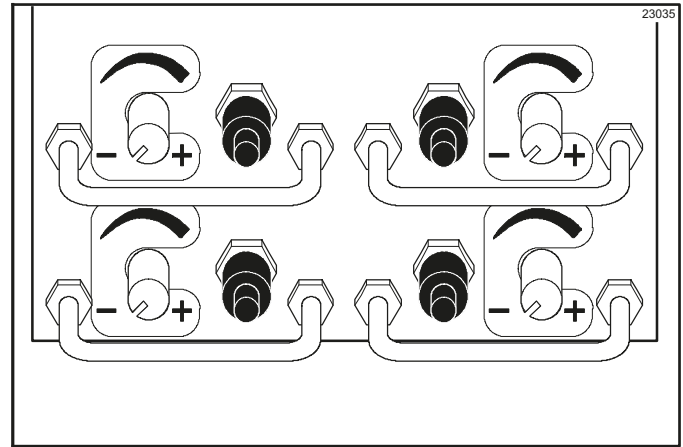

Figure 6-62

- Repeat steps 5 through 7 until 1 oz. (30 ml) of syrup is delivered
- Repeat steps 1 through 8 for each syrup flavor.
- Clean the calibration cup.

Note: Whenever a particular syrup line is not used, the syrup-hole plug found in the spare parts kit must be installed. Place the syrup-hole plug O-ring into the groove of the syrup-hole plug and lubricate it.

Syrup Priming

The purpose of priming the syrup line is to eliminate any air in the syrup delivery system. Each time a syrup container is drained or replaced, prime the syrup system until all the air has been removed and the syrup flow is uniform.

- Retrieve a full syrup container from the dry storage area.
- Shake the syrup container prior to opening it. Open the full syrup container.
- Pull the feed tube from the empty syrup container and clean the outside of the feed tube with a clean, sanitized towel.
- Place the feed tube into the full syrup container and replace the syrup container in the syrup cabinet.
- Dispose of the empty syrup container.
- Prime the syrup line by removing the syrup valve from the machine and hold it over an empty cup.

- Push the corresponding syrup flavor key. The light should be illuminated. (See Figure 6-63.)

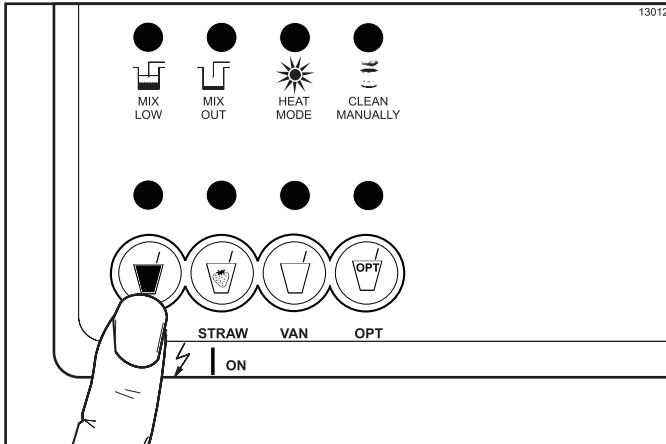

Figure 6-63

- Press the CAL key. A message will appear on the LCD.
- Press the WASH key to start the pump and to prime the syrup line.
- When a steady stream of syrup is flowing from the syrup valve, and all the air has been removed from the syrup line, press the CAL key again to stop the pump.

Note: There is a black prime button mounted at the top of the syrup cabinet (one per flavor), which speeds up the priming process. After the WASH key has been pressed, press and hold the corresponding black prime button in the syrup cabinet until the syrup flow out of the line is consistent and all air bubbles have been removed from the line. (See Figure 6-64.)

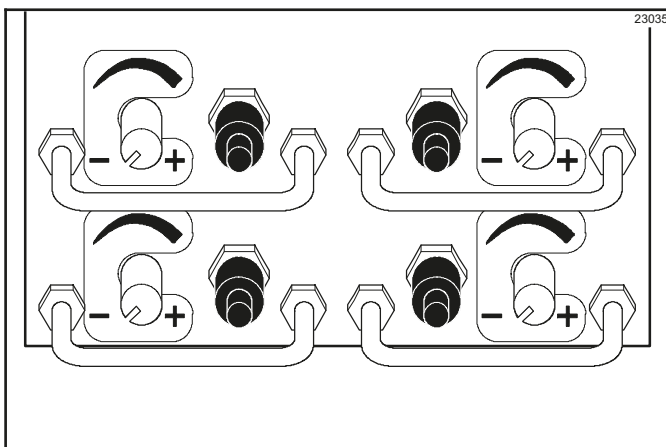

Figure 6-64

Closing Procedures

Important! This procedure must be completed every 2 weeks!



To disassemble the PH61, the following items will be needed:

- Two cleaning and sanitizing pails
- Cleaning brushes (provided with machine)
- Approved cleaning/sanitizing solution with active chlorine concentrate of 100 to 200 ppm
- Clean, sanitized towels
- Parts trays

Draining Product From the Freezing Cylinder

- Cancel automatic operation by pressing the AUTO key. (See Figure 6-65.)



Figure 6-65

- Remove the shake cup holder. Set it aside for cleaning later with all parts.
- Remove the hopper cover and agitator. Take these parts to the sink to wash, rinse, and sanitize.

OPERATING PROCEDURES

4. With a pail under the door spout, press the WASH and PUMP keys. Open the draw valve and start to drain the product from the freezing cylinder and mix hopper. (See Figure 6-66.)

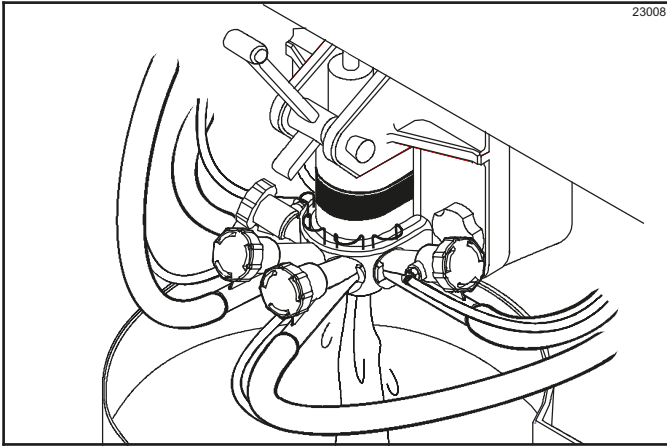

Figure 6-66

5. When the flow of product stops, press the WASH and PUMP keys, canceling the Wash and Pump modes. Close the draw valve. **Discard this product.** (See Figure 6-67.)

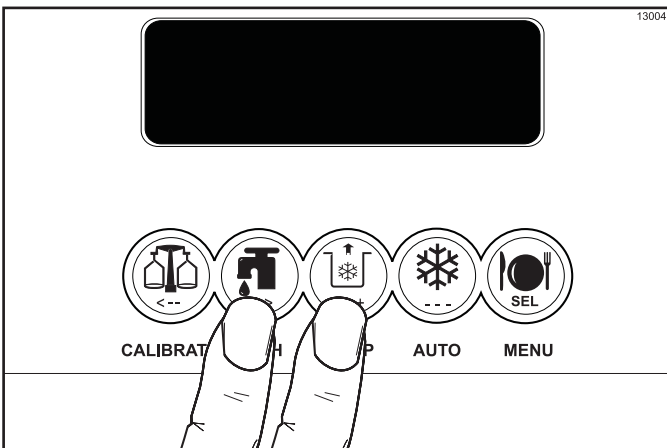

Figure 6-67

6. Remove the locking clip, mix feed tube, pump clip, and the assembled air/mix pump. Place the parts into the parts tray.
7. Remove the syrup lines from the freezer door by raising the syrup valve retainers and pulling the valves straight out of the door.

Rinsing

1. Pour 2 gal. (7.6 L) of cool, clean water into the mix hopper. With the white hopper brush, scrub the mix hopper, mix-level sensing probes, and the outside of the agitator driveshaft housing. Using the double-ended brush, brush-clean the mix inlet hole. (See Figure 6-68.)

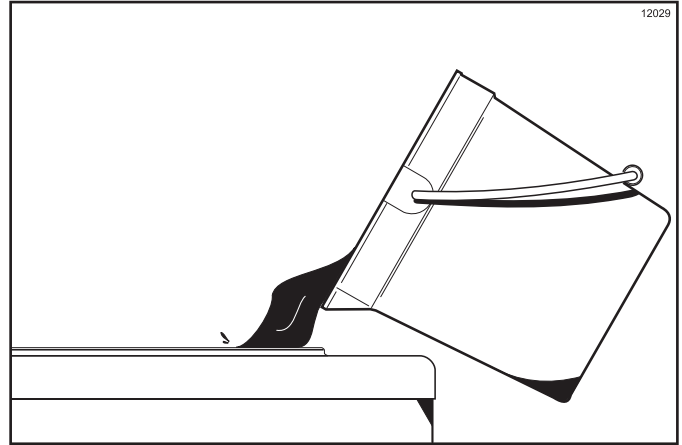

Figure 6-68

Note: Do not brush-clean the mix inlet hole while the machine is in the Wash mode.

2. With a pail beneath the door spout, press the WASH key. (See Figure 6-69.)

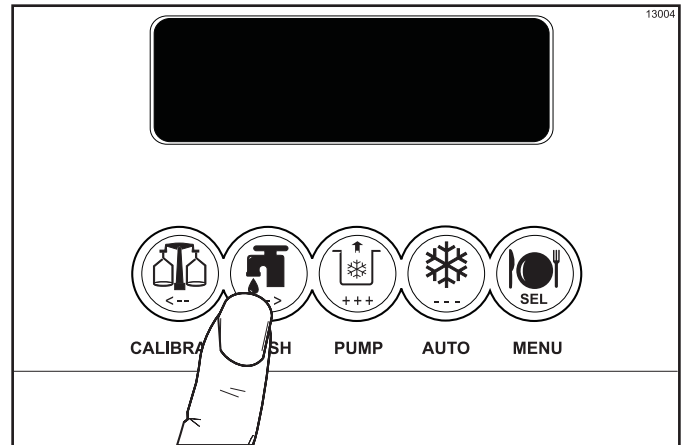

Figure 6-69

3. Open the draw valve on the freezer door. Drain all the rinse water from the door spout, close the draw valve, and press the WASH key, canceling the Wash cycle.
4. Repeat this procedure using clean, warm water until the water being discharged is clear.

Cleaning and Sanitizing

1. Prepare a 2.5 gal. (9.5 L) pail of a cleaning/sanitizing solution with an active chlorine concentrate of 100 to 200 ppm approved for use by your company. Use warm water and follow the cleaning/sanitizing solution manufacturer's specifications.
2. Pour the solution into the hopper and allow it to flow into the freezing cylinder.
3. Using the white hopper brush, clean the mix hopper, mix-level sensing probes and the outside of the agitator driveshaft housing. Using the double-ended brush, clean the mix inlet hole.

Note: *Do not brush-clean the mix inlet hole while the machine is in the Wash mode.*

4. Press the WASH key. This will cause the cleaning solution in the freezing cylinder to come in contact with all areas of the freezing cylinder.
5. Place an empty pail beneath the door spout.
6. Open the draw valve on the freezer door and draw off all the solution.
7. Once the cleaning solution stops flowing from the door spout, close the draw valve and press the WASH key, canceling the Wash mode.
8. Prepare 2.5 gal. (9.5 L) of cleaning/sanitizing solution.

Repeat steps 2 through 7 with the sanitizing solution.

Disassembly

Note: *Failure to remove the parts specified below for brush-cleaning and lubrication will damage the machine. These parts must be removed every 14 days or the machine will lock out and will not operate.*



WARNING! Make sure the power switch is in the OFF position. Failure to follow this instruction may result in severe personal injury from hazardous moving parts.

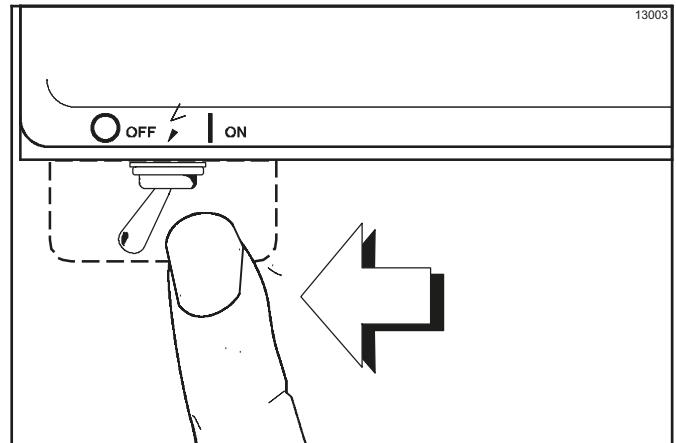

Figure 6-70

In order for the control to recognize that the machine has been brush-cleaned, the following criteria must be met:

- All freezing cylinder and hopper temperatures must be above 60°F (16°C).
- The Mix Out and Mix Low probes must not be satisfied.
- The power switch must remain in the OFF position for at least 5 minutes.

Note: *These criteria must be met simultaneously. These criteria will be met when the machine is properly brush-cleaned.*

The following screen is displayed if the machine is not in a brush-clean state. (See Figure 6-71.) If any of the requirements for a brush-clean have not been met, the time displayed will remain at 5:00 minutes.

POWER SWITCH OFF		
OUT	TIME: 4:40	OUT
68.5	HOPPER	62.1
69.5	BARREL	67.7

Figure 6-71

OPERATING PROCEDURES

When all the requirements for a brush-cleaning are met and the 5 minutes expire, the screen will change to the second screen, which is the standard POWER SWITCH OFF screen. (See Figure 6-72.)

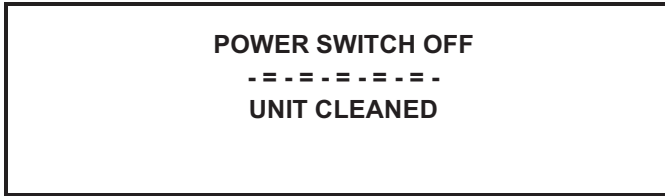

Figure 6-72

When the power switch is set in the ON position, the System Mode of Operation screen is displayed. In this example, the machine is ON but no mode of operation has been selected. The second line of the display indicates whether there is a sufficient supply of mix in the hopper or if there is a MIX LOW or MIX OUT condition. The third line of the display shows the temperature of the mix hopper. After pressing the AUTO key, the last line of the display shows the month and date (MM = month, DD = day) that the machine needs to be disassembled and brush-cleaned. (See Figure 6-73.)

6

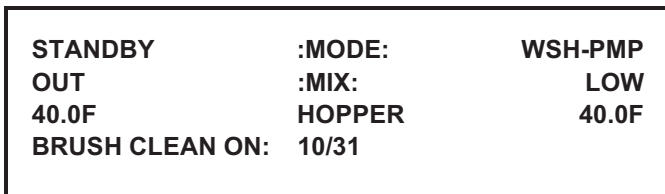

Figure 6-73

Note: The MANUAL CLEAN LED will begin flashing 24 hours prior to a 14-day lockout. The four mode LEDs will return to their normal function when the machine is unlocked.

With the parts tray available for the shake side, remove the following parts and place in the parts tray:

1. Remove the syrup lines from the syrup ports, and remove the restrictor cap from the bottom of the door spout.
2. Remove the spinner blade from the bottom of the door spout by lifting up the locking collar on the spinner coupling and pulling down the blade.

3. Remove the handscrews, freezer door, beater assembly with driveshaft seal, and scraper blades from the freezing cylinder.
4. Remove the driveshaft seal from the driveshaft of the beater assembly.
5. Remove the freezer door O-ring, front bearing, pivot pin, draw handle, and draw valve spinner assembly. Remove the O-ring from the pivot pin.
6. Disassemble the draw valve spinner assembly. Remove the driven spinner by grasping the draw valve and pulling the driven spinner out. Remove the spinner shaft seal.
7. Remove the two O-rings from the draw valve.

Note: To remove O-rings, use a clean, sanitized towel to grasp the O-ring. Apply pressure upward until the O-ring pops out of its groove. With the other hand, push the top of the O-ring forward and it will roll out of the groove and can easily be removed. If there is more than one O-ring to be removed, always remove the rear O-ring first. This will allow the O-ring to slide over the forward O-rings without falling into the open grooves.

8. From the pump cylinder, remove the retaining pin, valve cap, piston, and the feed tube. Remove all O-rings and the check ring.
9. Remove the pump driveshaft from the drive hub in the rear wall of the mix hopper.
10. Remove the two small O-rings and one large O-ring from the driveshaft.

Note: If the drip pans are filled with an excessive amount of mix, it is an indication that the driveshaft seal(s), or O-ring(s) should be replaced or properly lubricated.

Brush-Cleaning

1. Prepare the three-compartment sink for washing, rinsing, and sanitizing. Fill the first sink with an approved cleaning solution, the second sink with cool, clean water, and the third sink with a cleaning/sanitizing solution with an active chlorine concentrate of 100 to 200 ppm. Use warm water and follow the cleaning/sanitizing solution manufacturer's specifications.

Make sure all brushes provided with the freezer are available for brush-cleaning.

2. Thoroughly wash all disassembled parts and the parts trays, making sure all lubricant and mix film is removed. Make sure to brush-clean all surfaces and holes, especially the holes in the pump valve body and the small syrup holes in the freezer door.
3. Rinse and sanitize all parts, one tray at a time, including the tray.

Note: When sanitizer is used, it must always have a minimum contact time of 5 minutes. Afterward, if required by your local code, rinse with clean water.
4. Place disassembled parts on clean and sanitized parts trays.
5. Return to the machine with a small amount of cleaning/sanitizing solution. Using the black brush, clean the rear shell bearings at the back of the freezing cylinder. (See Figure 6-74.)

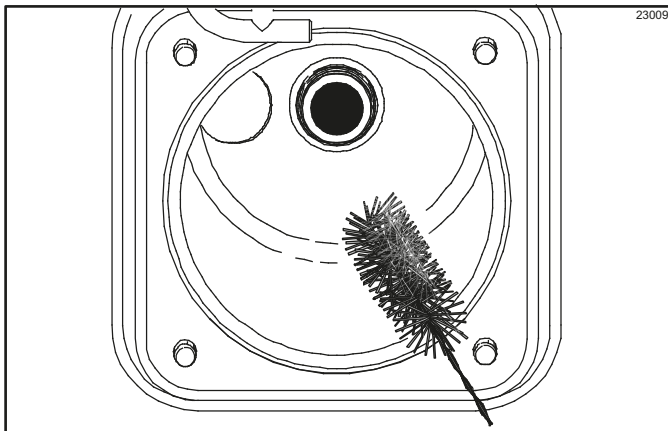

Figure 6-74

6. Using the black brush, clean the drive hub opening in the rear wall of the mix hopper. (See Figure 6-75.)

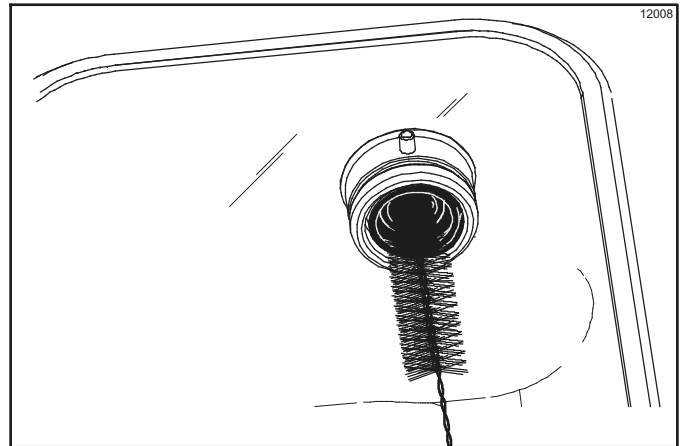

Figure 6-75

7. Using the double-end brush, brush-clean the syrup line fittings.
8. Wipe all exterior surfaces of the machine with a clean, sanitized towel.

Sanitizing the Syrup Lines

Important! The syrup lines must be sanitized weekly.

1. Prepare a 2.5 gal. (9.5 L) pail of a cleaning/sanitizing solution with an active chlorine concentrate of 100 to 200 ppm approved for use by your company. Use warm water and follow the cleaning/sanitizing solution manufacturer's specifications.
2. Remove the syrup feed tubes from the syrup containers. Wipe the outside of the feed tubes with a clean, sanitized towel.
3. Place the syrup feed tubes in the pail of solution. To prevent contamination, cover the syrup containers with plastic wrap.
4. Select a flavor from the control panel and remove the corresponding syrup valve from the door. Place the valve in a pail under the draw valve.
5. Press the CAL key on the control panel to enter the Calibration mode.
6. Press the WASH key on the control panel to start the flow of cleaning/sanitizing solution through the syrup line.
7. Allow the solution to flow until all of the syrup is flushed from the line.
8. Press the CAL key on the control panel to stop the flow of solution.

9. Disassemble the syrup valve. To remove the syrup valve cap, push down and turn counterclockwise. Push the valve plunger out of the syrup valve. (See Figure 6-76.)

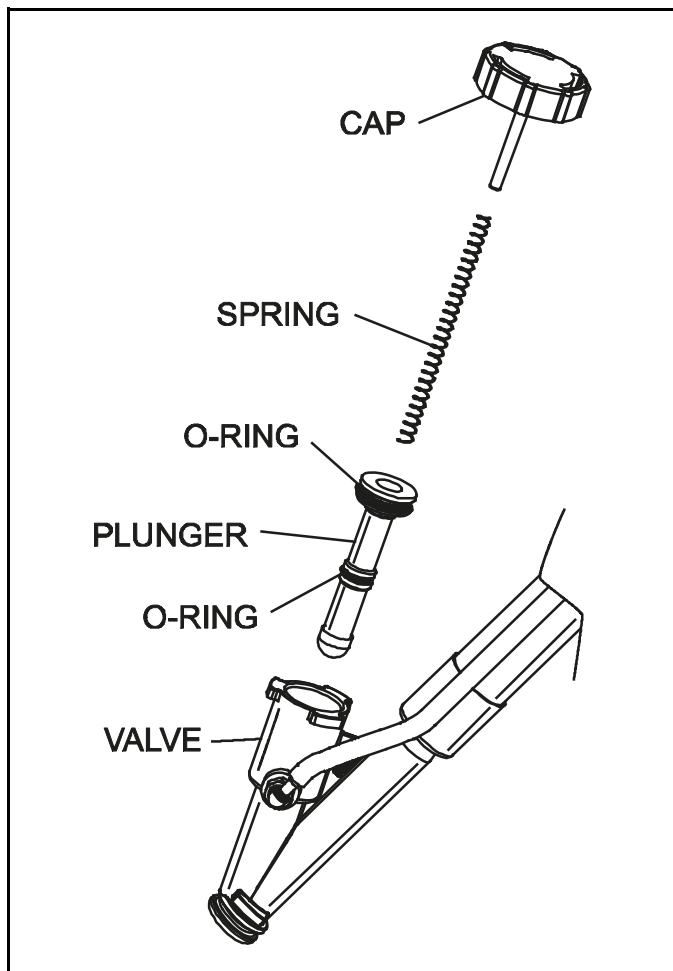

Figure 6-76

10. Using a clean, sanitized towel, gently wipe any syrup and lubricant from the plunger.
11. Using the white end of the double-ended brush, scrub the inside of the syrup valve body and syrup line to remove any residual particles.
12. Using a shake cup filled with cleaning/sanitizing solution, rinse the syrup valve body thoroughly.
13. Lubricate the two O-rings on the plunger lightly with Taylor Lube HP.
14. Re-install the plunger into the valve body and install the cap and spring assembly. Push down on the cap and turn it clockwise until it locks.
(**Note:** The cap will click when locked.)
15. Repeat steps 3 through 13 for all syrup flavors.

16. Remove the syrup feed tubes from the pail of solution and allow them to drain.
17. Replace all of the syrup feed tubes into the syrup containers. Ensure syrup lines match their respective flavors.
18. Select a flavor. Press the CAL key on top of the control panel to enter the Calibration mode.
19. Press the WASH key on the control panel to start the flow of syrup.
20. Allow the syrup to flow until all of the cleaning/sanitizing solution is flushed from the line.
21. Press the CAL key on the control panel to stop the flow of syrup.
22. Install the valve into the shake door.
23. Repeat steps 15 through 21 for all syrup flavors.
24. Clean the syrup cabinet interior with a clean, sanitized towel. Spray resistant areas with cleaning/sanitizing solution.

Pump Tube Replacement

Note: The pump tubes should be replaced annually.

Pump Tube Removal

1. Prepare a 2.5 gal. (9.5 L) pail of a cleaning/sanitizing solution with an active chlorine concentrate of 100 to 200 ppm approved for use by your company. Use warm water and follow the cleaning/sanitizing solution manufacturer's specifications.
2. Remove the syrup feed tubes from the syrup containers. Wipe the outside of the feed tubes with a clean, sanitized towel.
3. Remove the syrup jugs and the pump cover tray from inside the cabinet.
4. Place the syrup feed tubes in the pail of cleaning/sanitizing solution. To avoid contamination, cover the syrup containers with plastic wrap.
5. Select a flavor from the control panel and remove the corresponding syrup valve from the door. Place the valve in a pail under the draw valve.
6. Press the CAL key on the control panel to enter the Calibration mode.
7. Press the WASH key on the control panel to start the flow of solution through the syrup line.
8. Allow the cleaning/sanitizing solution to flow until all of the syrup is flushed from the line.

9. Press the CAL key on the control panel to stop the flow of cleaning solution.
10. Once the line is free of syrup, remove the syrup feed tube from the cleaning solution. Run the pump until the syrup line is free from liquid.
11. Prepare a 2.5 gal. (9.5 L) pail of a cleaning/sanitizing solution with an active chlorine concentrate of 100 to 200 ppm approved for use by your company. Use warm water and follow the cleaning/sanitizing solution manufacturer's specifications.
12. Repeat steps 3 through 10 using this solution to sanitize.
13. Open the pump by pushing up on the hinged cover. (See the arrow in Figure 6-77 on page 6-23)

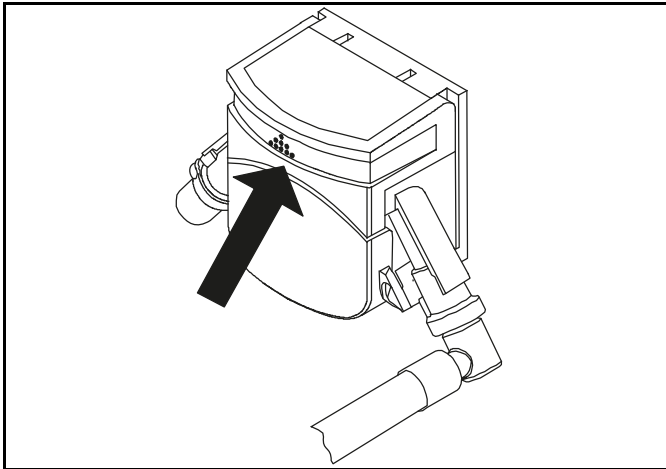

Figure 6-77

14. Grasp the pump tube by both ends and remove it from the pump body. (See Figure 6-78.

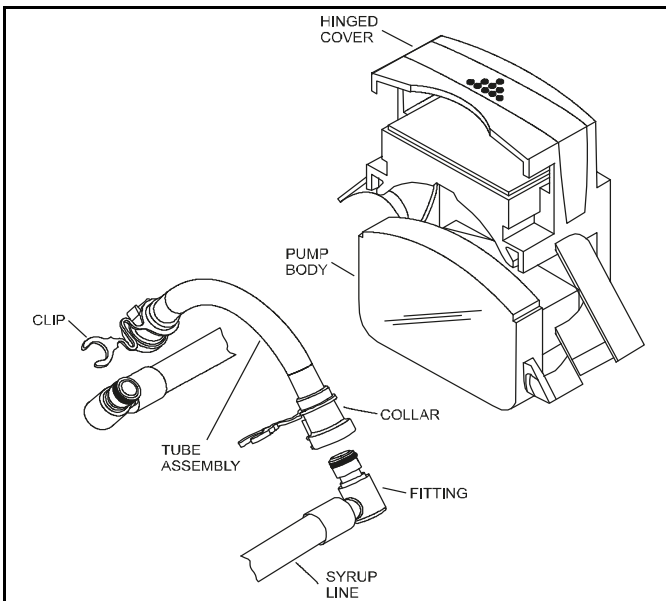

Figure 6-78

15. Remove the clips from their respective collars.
16. Remove the fittings from the pump tube.

Pump Tube Installation

1. Lubricate the O-rings on the syrup line fittings with Taylor Lube HP. (See Figure 6-79.)

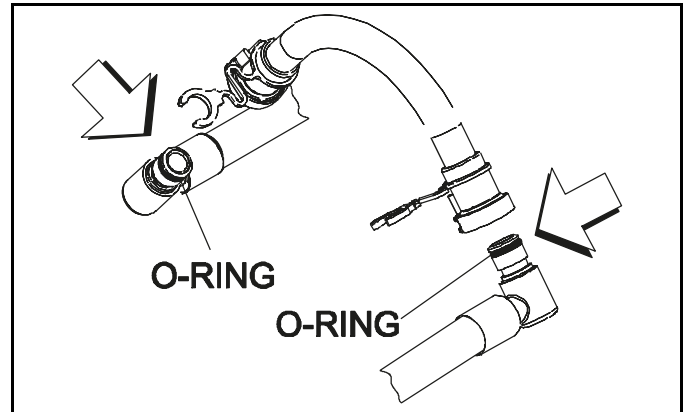

Figure 6-79

2. Press the fittings into the new pump tube.
3. Install the clips into their collars.
4. Using your hands. Rotate the pump rollers so they are in the 10 and 2 o'clock position.
5. Place the tube assembly into the pump body. (Make sure the syrup lines are pushed through the rear of the cabinet.)
6. Push down on the top of the pump to close it.
7. Replace the pump cover tray and the syrup jugs.
8. Prime the syrup lines.
9. Calibrate the syrup system according to the instructions on page 6-15.

During Cleaning and Sanitizing



ALWAYS FOLLOW LOCAL HEALTH CODES.



NOTICE! Cleaning and sanitizing schedules are governed by your federal, state or local regulatory agencies and must be followed accordingly. Please see the cleaning section of the manual for the proper procedure to clean this machine.

The following checkpoints should be stressed during the cleaning and sanitizing operations:

Important! *Cleaning and sanitizing must be performed every 14 days.*

Important! *Syrup lines must be sanitized weekly.*

Troubleshooting Bacterial Count

- Thoroughly clean and sanitize the machine regularly, including complete disassembly and brush-cleaning.
- Use all brushes supplied for thorough cleaning. The brushes are specially designed to reach all mix passageways.
- Use the white bristle brush to clean the mix inlet hole, which extends from the mix hopper down to the rear of the freezing cylinder.
- Use the black bristle brush to thoroughly clean the rear shell bearing at the rear of the freezing cylinder. Make sure to use a generous amount of cleaning solution on the brush.
- Properly prepare the cleaning and sanitizing solutions. Read and follow the label directions carefully. Too **strong** of a solution may damage the parts, and too **weak** of a solution will not do an adequate job of cleaning or sanitizing.
- Thoroughly clean and sanitize the syrup lines at least once a week.
- The temperature of mix in mix hopper and walk-in cooler should be below 40°F (4.4°C).
- Discard remaining mix from freezer during Closing Procedures.

Regular Maintenance Checks

- Rotate scraper blades to allow both sides of the knife edge to wear evenly. This will contribute to self-sharpening and help maintain fast, efficient freezing.
- Replace scraper blades that are bent, damaged, or worn down.
- Before installing beater, make sure scraper blades are properly attached over the beater pins.
- Dispose of O-rings and seals if they are worn, torn, or fit too loosely, and replace with new ones.
- Check the rear shell bearing for signs of wear (excessive mix leakage in rear drip pan) and make sure it is properly cleaned.
- Using a screwdriver and cloth towel, clean the rear shell bearing and the female drive socket of lubricant and mix deposits.
- Follow all lubricating procedures as outlined in Machine Setup on page 6-1.
- On air-cooled machines, check the condenser for dirt and lint. Dirty condensers will reduce the efficiency and capacity of the machine. Condensers and filters should be cleaned monthly. Remove the rear panel to gain access to the condenser. Use a soft brush to clean between the fins of the condenser. Never use screwdrivers or other metal probes to clean between the fins.
- On water-cooled machines, check the water lines for kinks or leaks. Kinks can occur when the machine is moved back and forth for cleaning or maintenance. Deteriorated or cracked water lines should be replaced only by a Taylor service technician.

Winter Storage

If the place of business is to be closed during the winter months, it is important to protect the freezer by following certain precautions, particularly if the building is to be left unheated and subject to freezing conditions.

Disconnect the freezer from the main power source to prevent possible electrical damage.

On water-cooled freezers, disconnect the water supply. Use air pressure to blow out any water remaining in the condensers. **This is extremely important.** Failure to follow this procedure may cause severe and costly damage to the refrigeration system.

Your local Taylor distributor can perform this service for you.

Wrap detachable parts of the freezer such as beater assembly and freezer door, and place in a protected, dry place. Rubber trim parts and gaskets can be protected by wrapping with moisture-proof paper. All parts should be thoroughly cleaned of dried mix or lubrication accumulations, which can attract mice and other vermin.

Table 8-1

Problem	Probable Cause	Corrective Action
1. All four LEDs are flashing.	a. The machine is locked.	a. See soft lock and hard lock information.
2. Soft lock message appears on LCD.	<ul style="list-style-type: none"> a. More than 24 hours since the last Heat cycle. b. The power switch is in the OFF position. c. The machine is not in the Auto mode. d. MIX OUT condition. e. The agitator is not installed. f. The agitator is not rotating. g. A machine fault has occurred. 	<ul style="list-style-type: none"> a. The machine must go through a Heat cycle every 24 hours. The freezer must now be disassembled and brush-cleaned or placed in a Heat cycle. b. The power switch must be in the ON position. The freezer must now be disassembled and brush-cleaned or placed in a Heat cycle. c. The machine must be in the Auto mode. The freezer must now be disassembled and brush-cleaned or placed in a Heat cycle. d. The level of mix in the machine must now be disassembled and brush-cleaned or placed in a Heat cycle. e. The agitator must be cleaned and installed before starting the Heat cycle. The freezer must now be disassembled and brush-cleaned. f. The agitator must be cleaned before starting the Heat cycle. Disassemble the freezer and brush-clean. g. See Screen H in the Operator's Menu to determine the cause.
3. Hard lock message appears on the LCD.	<ul style="list-style-type: none"> a. A barrel or hopper thermistor is faulty. b. More than 14 days since the last brush-cleaning. 	<ul style="list-style-type: none"> a. Call a Taylor service technician. b. The machine must be disassembled and brush-cleaned every 14 days.
4. No product is being dispensed.	<ul style="list-style-type: none"> a. Low on mix. The MIX OUT light is ON. b. The power switch is in the OFF position. c. Freeze-up in mix inlet hole. d. Beater motor is out on reset. e. Air/mix pump is incorrectly assembled or improperly lubricated. f. The mix pump ball crank is broken. g. The pump motor is not activated. 	<ul style="list-style-type: none"> a. Add mix to the mix hopper. b. Place the power switch to ON and press the AUTO key. c. Call Taylor service technician. d. Clear the tone. Allow the beater motor to cool. Place the power switch to OFF. Press the RESET button firmly, place the power switch to ON, and press the WASH key. Open the side access panel and observe that the driveshaft is turning clockwise as viewed from the front of the machine. Press the AUTO key to return to the Auto mode. If the beater motor should go OFF on reset again, call a Taylor service technician. e. Follow assembly procedures carefully. f. Call a Taylor service technician. g. Push the reset button. The draw valve must be fully opened to activate the pump motor.

TROUBLESHOOTING GUIDE

Problem	Probable Cause	Corrective Action
5. The product is too thick.	<ul style="list-style-type: none"> a. Not enough syrup - 1 fluid oz. (30 ml) in 5 seconds. b. Insufficient mix in the freezing cylinder. c. Improper priming procedures. d. Air/mix pump incorrectly assembled. e. The viscosity control is set too cold. f. Freeze-up in mix inlet hole. 	<ul style="list-style-type: none"> a. Calibrate the syrups. Check that the syrup tanks have an adequate syrup supply. b. Check the air/mix pump assembly. c. Drain the freezing cylinder and reprime the machine. d. Follow assembly procedures carefully. e. Call a Taylor service technician. f. Call a Taylor service technician.
6. Product is too soft.	<ul style="list-style-type: none"> a. Too much syrup - 1 fluid oz. (30 ml) in 5 seconds. b. Outdrawing capacity of freezing cylinder. c. Inadequate airspace. d. Dirty condenser or air filters on air-cooled machines. e. Inadequate water supply on water-cooled machines. f. Bad scraper blades. g. The viscosity control is set too warm. h. Air passage is blocked in the pump. 	<ul style="list-style-type: none"> a. Calibrate syrups. b. Continuous draw rate is approximately one 16 oz. (473 ml) shake by volume every 15 to 20 seconds. c. Minimum of 6 in. (152 mm) airspace around all sides. d. Clean regularly. e. Check the water supply. Check the water lines for leaks or kinks. f. Replace the scraper blades. g. Call a Taylor service technician. h. Brush-clean the pump components and reassemble.
7. The mix in the hopper is too warm.	<ul style="list-style-type: none"> a. Hopper cover is not in position. b. The agitator is not installed. c. The hopper temperature is out of adjustment. 	<ul style="list-style-type: none"> a. Clean the hopper cover and place in position. b. Clean the agitator and install. c. Call a Taylor service technician.
8. The mix in hopper is too cold.	<ul style="list-style-type: none"> a. The hopper temperature is out of adjustment. 	<ul style="list-style-type: none"> a. Call a Taylor service technician.
9. Product is collecting on top of draw valve.	<ul style="list-style-type: none"> a. Inadequate lubrication of spinner shaft or seal. b. Spinner shaft seal is missing or worn. 	<ul style="list-style-type: none"> a. Lubricate properly. b. Install or replace the spinner shaft seal.
10. Product is collecting on top of the freezer door.	<ul style="list-style-type: none"> a. The top O-ring on draw valve is improperly lubricated or worn. 	<ul style="list-style-type: none"> a. Lubricate properly or replace the O-ring.
11. Excessive mix leakage from the bottom of door spout.	<ul style="list-style-type: none"> a. Bottom O-ring on draw valve is improperly lubricated or worn. 	<ul style="list-style-type: none"> a. Lubricate properly or replace the O-ring.

Problem	Probable Cause	Corrective Action
12.Excessive mix leakage into the long drip pan.	<ul style="list-style-type: none"> a. The seal on driveshaft is improperly lubricated or worn. b. The seal is installed inside out on the driveshaft. c. Worn or missing O-rings on pump driveshaft. d. Inadequate lubrication of the driveshaft. e. The driveshaft and beater assembly worked forward. f. Worn rear shell bearing. g. Gearbox is out of alignment. 	<ul style="list-style-type: none"> a. Lubricate properly or replace the seal. b. Install correctly. c. Install or replace the O-rings. d. Lubricate properly. e. Call a Taylor service technician. f. Call a Taylor service technician. g. Call a Taylor service technician.
13.The driveshaft is stuck in the drive coupling.	<ul style="list-style-type: none"> a. Mix and lubricant collected in drive coupling. b. Rounded corners of driveshaft, drive coupling, or both. c. Gearbox is out of alignment. 	<ul style="list-style-type: none"> a. Brush-clean the rear shell bearing area regularly. b. Call a Taylor service technician. c. Call a Taylor service technician.
14.Freezing cylinder walls scored.	<ul style="list-style-type: none"> a. Missing or worn front bearing. b. Broken beater pins. c. Gearbox is out of alignment. 	<ul style="list-style-type: none"> a. Install or replace the front bearing. b. Repair or replace the beater assembly. When installing scraper blades, make sure they are properly attached over the pins. c. Call a Taylor service technician.
15.Spinner shaft will not rotate to blend mix and syrup.	<ul style="list-style-type: none"> a. Flexible coupling is broken. b. Pin is missing in quick disconnect of spinner coupling. c. Spinner motor is out on thermal overload. 	<ul style="list-style-type: none"> a. Call a Taylor service technician. b. Call a Taylor service technician. c. Allow the spinner motor to cool. Also check lubrication on spinner shaft. Properly align the motor and lubricate properly.
16.Large adjustments are necessary to receive 1 oz. (30 ml) in 5 seconds.	<ul style="list-style-type: none"> a. The pump tube has collapsed. b. Syrup lines are not matched with correct syrup flavor. c. The plunger is sticking in the syrup valve. d. Plugged syrup line fitting at freezer door connection. e. Verify that the proper syrup selection was made. 	<ul style="list-style-type: none"> a. Replace the pump tube. b. Match the color wrapped syrup lines to the correct syrup flavors. c. Clean the valve. d. Clean the syrup line fitting. e. Make the proper syrup selection.
17.Pump will not operate in the Pump mode.	<ul style="list-style-type: none"> a. Pump motor is not activated. b. The membrane switch is defective. 	<ul style="list-style-type: none"> a. Push the reset button. b. Call a Taylor service technician.

TROUBLESHOOTING GUIDE

Problem	Probable Cause	Corrective Action
18. Machine will not run when in the Auto mode.	<ul style="list-style-type: none"> a. Machine is unplugged. b. Beater motor is out on reset. c. Circuit breaker OFF or blown fuse. d. Low on mix. The MIX OUT light is ON. e. Water is turned OFF on water-cooled machines. 	<ul style="list-style-type: none"> a. Plug into wall receptacle. b. Clear the tone. Allow the beater motor to cool. Place the power switch to OFF. Press the RESET button firmly. Place the power switch to ON and press the WASH key. Open the side access panel and observe that the driveshaft is turning clockwise as viewed from the front of the machine. Press the AUTO key to return to the Auto mode. If the beater motor should go OFF on reset again, call a Taylor service technician. c. Turn the breaker ON or replace the fuse and clear the fault. d. Add mix to the mix hopper and press the AUTO key. e. Turn water ON and clear the fault.
19. Air compressor runs too often for normal usage.	<ul style="list-style-type: none"> a. Air leak in the system. 	<ul style="list-style-type: none"> a. Use a soap solution to locate the leak and repair.
20. LCD is blank.	<ul style="list-style-type: none"> a. Machine is unplugged. b. Circuit breaker is OFF or blown fuse. c. Component failure. d. LCD intensity needs adjusting. 	<ul style="list-style-type: none"> a. Plug into wall receptacle. b. Turn the circuit breaker ON or replace the fuse and clear the fault. c. Call a Taylor service technician. d. Call a Taylor service technician.
21. Product is not feeding into the freezing cylinder.	<ul style="list-style-type: none"> a. The mix inlet hole is frozen up. 	<ul style="list-style-type: none"> a. The hopper temperature needs adjustment. Call a Taylor service technician.
22. The draw handle does not close.	<ul style="list-style-type: none"> a. Mix is on the sensing eye. 	<ul style="list-style-type: none"> a. Clean the sensing eye.
23. Product popping when drawn.	<ul style="list-style-type: none"> a. Pump assembled incorrectly. 	<ul style="list-style-type: none"> a. Assemble and lubricate according to instructions in this manual.
24. Machine shuts off but fault tone continues.	<ul style="list-style-type: none"> a. Fault has occurred in the freezer. b. Inadequate air clearance around the freezer. 	<ul style="list-style-type: none"> a. Verify condition in the Operator's Menu fault screen. Clear fault accordingly. b. Minimum of 6 in. (152 mm) airspace around all sides to prevent recirculation of warm air.
25. Syrup flows constantly or not at all. Difficult to calibrate syrups.	<ul style="list-style-type: none"> a. Syrup lines are clogged. b. The pump tube has collapsed. c. The syrup valve plunger is stuck. 	<ul style="list-style-type: none"> a. Disassemble and clean the syrup valves. Flush syrup lines with warm water and sanitize weekly. b. Replace the pump tube. c. Disassemble and clean the syrup valve.
26. Shakes have air bubbles in them.	<ul style="list-style-type: none"> a. Syrup valves are clogged. 	<ul style="list-style-type: none"> a. Disassemble and clean the syrup valves.
27. Mix Low and Mix Out probes are not functioning.	<ul style="list-style-type: none"> a. Milkstone buildup in the hopper. 	<ul style="list-style-type: none"> a. Clean hoppers thoroughly.

Section 9

Parts Replacement Schedule

Table 9-1

Part Description	Every 3 Months	Every 6 Months	Annually
Scraper Blade-Shake		X	
Driveshaft Seal	X		
Freezer Door O-ring-Shake	X		
Front Bearing	X		
Draw Valve O-ring	X		
Spinner Shaft Seal-Shake	X		
Pivot Pin O-ring	X		
Restrictor Cap-Shake	X		
Mix Feed Tube O-ring	X		
Pump O-ring	X		
Mix Inlet Tube O-ring	X		
Mix Feed Tube Check Ring	X		
Air Inlet Fitting Seal	X		
Pump Driveshaft O-ring	X		
Pump Valve Gasket	X		
White Bristle Brush, 3" x 7"		Inspect and replace if necessary.	Minimum
Peristaltic Pump Tubes		Inspect and replace if necessary.	Minimum
White Bristle Brush, 1-1/2" x 2"		Inspect and replace if necessary.	Minimum
White Bristle Brush, 1" x 2"		Inspect and replace if necessary.	Minimum
Black Bristle Brush, 1" x 2"		Inspect and replace if necessary.	Minimum
Double-Ended Brush		Inspect and replace if necessary.	Minimum
Door-spout Brush		Inspect and replace if necessary.	Minimum
Brush Set (3)		Inspect and replace if necessary.	Minimum

TAYLOR COMPANY LIMITED WARRANTY ON FREEZERS

Taylor Company is pleased to provide this limited warranty on new Taylor-branded freezer machine available from Taylor to the market generally (the "Product") to the original purchaser only.

LIMITED WARRANTY

Taylor warrants the Product against failure due to defect in materials or workmanship under normal use and service as follows. All warranty periods begin on the date of original Product installation. If a part fails due to defect during the applicable warranty period, Taylor, through an authorized Taylor distributor or service agency, will provide a new or remanufactured part, at Taylor's option, to replace the failed defective part at no charge for the part. Except as otherwise stated herein, these are Taylor's exclusive obligations under this limited warranty for a Product failure. This limited warranty is subject to all provisions, conditions, limitations, and exclusions listed below and on the reverse (if any) of this document.

Table 10-1

Product	Part	Limited Warranty Period
Soft Serve	Insulated shell assembly	Five (5) years
Frozen Yogurt	Refrigeration compressor (except service valve)	Five (5) years
Shakes Smoothies	Beater motors	Two (2) years
Frozen Beverage	Beater drive gear	Two (2) years
Batch Desserts	Printed circuit boards and Softech™ controls beginning with serial number H8024200	Two (2) years
	Parts not otherwise listed in this table or excluded below	One (1) year

LIMITED WARRANTY CONDITIONS

1. If the date of original installation of the Product cannot be verified, then the limited warranty period begins ninety (90) days from the date of Product manufacture (as indicated by the Product serial number). Proof of purchase may be required at time of service.
2. This limited warranty is valid only if the Product is installed and all required service work on the Product is performed by an authorized Taylor distributor or service agency, and only if genuine, new Taylor parts are used.
3. Installation, use, care, and maintenance must be normal and in accordance with all instructions contained in the Taylor Operator's Manual.
4. Defective parts must be returned to the authorized Taylor distributor or service agency for credit.
5. The use of any refrigerant other than that specified on the Product's data label will void this limited warranty.

LIMITED WARRANTY ON EQUIPMENT

LIMITED WARRANTY EXCEPTIONS

This limited warranty does **not** cover:

1. Labor or other costs incurred for diagnosing, repairing, removing, installing, shipping, servicing, or handling of defective parts, replacement parts, or new Products.
2. Normal maintenance, cleaning, and lubrication as outlined in the Taylor Operator's Manual, including cleaning of condensers.
3. Replacement of wear items designated as Class "000" parts in the Taylor Operator's Manual.
4. External hoses, electrical power supplies, and machine grounding.
5. Parts not supplied or designated by Taylor, or damages resulting from their use.
6. Return trips or waiting time required because a service technician is prevented from beginning warranty service work promptly upon arrival.
7. Failure, damage, or repairs due to faulty installation, misapplication, abuse, no or improper servicing, unauthorized alteration, or improper operation or use as indicated in the Taylor Operator's Manual, including but not limited to the failure to use proper assembly and cleaning techniques, tools, or approved cleaning supplies.
8. Failure, damage, or repairs due to theft, vandalism, wind, rain, flood, high water, water, lightning, earthquake, or any other natural disaster, fire, corrosive environments, insect or rodent infestation, or other casualty, accident or condition beyond the reasonable control of Taylor; operation above or below the electrical or water supply specification of the Product; or components repaired or altered in any way so as, in the judgment of the Manufacturer, to adversely affect performance, or normal wear or deterioration.
9. Any Product purchased over the Internet.
10. Failure to start due to voltage conditions, blown fuses, open circuit breakers, or damages due to the inadequacy or interruption of electrical service.
11. Electricity or fuel costs, or increases in electricity or fuel costs from any reason whatsoever.
12. Damages resulting from the use of any refrigerant other than that specified on the Product's data label will void this limited warranty.
13. Any cost to replace, refill, or dispose of refrigerant, including the cost of refrigerant.
- 14. ANY SPECIAL, INDIRECT, OR CONSEQUENTIAL PROPERTY OR COMMERCIAL DAMAGE OF ANY NATURE WHATSOEVER.** Some jurisdictions do not allow the exclusion of incidental or consequential damages, so this limitation may not apply to you.

This limited warranty gives you specific legal rights, and you may also have other rights which vary from jurisdiction to jurisdiction.

LIMITATION OF WARRANTY

THIS LIMITED WARRANTY IS EXCLUSIVE AND IS IN LIEU OF ALL OTHER WARRANTIES, CONDITIONS, AND/OR REMEDIES UNDER THE LAW, INCLUDING ANY IMPLIED WARRANTIES OR CONDITIONS OF MERCHANTABILITY OR FITNESS FOR A PARTICULAR PURPOSE. THE ORIGINAL OWNER'S SOLE REMEDY WITH RESPECT TO ANY PRODUCTS SHALL BE REPAIR OR REPLACEMENT OF DEFECTIVE COMPONENTS UNDER THE TERMS OF THIS LIMITED WARRANTY. ALL RIGHTS TO CONSEQUENTIAL OR INCIDENTAL DAMAGES (INCLUDING CLAIMS FOR LOST SALES, LOST PROFITS, PRODUCT LOSS, PROPERTY DAMAGES, OR SERVICE EXPENSES) ARE EXPRESSLY EXCLUDED. THE EXPRESS WARRANTIES MADE IN THIS LIMITED WARRANTY MAY NOT BE ALTERED, ENLARGED, OR CHANGED BY ANY DISTRIBUTOR, DEALER, OR OTHER PERSON, WHATSOEVER.

LEGAL REMEDIES

The owner **must** notify Taylor in writing, by certified or registered letter to the following address, of any defect or complaint with the Product, stating the defect or complaint and a specific request for repair, replacement, or other correction of the Product under warranty, mailed at least thirty (30) days before pursuing any legal rights or remedies.

Taylor Company
750 N. Blackhawk Blvd.
Rockton, IL 61072, U.S.A.

TAYLOR COMPANY LIMITED WARRANTY ON TAYLOR GENUINE PARTS

Taylor Company is pleased to provide this limited warranty on new Taylor genuine replacement components and parts available from Taylor to the market generally (the "Parts") to the original purchaser only.

LIMITED WARRANTY

Taylor warrants the Parts against failure due to defect in materials or workmanship under normal use and service as follows. All warranty periods begin on the date of original installation of the Part in the Taylor machine. If a Part fails due to defect during the applicable warranty period, Taylor, through an authorized Taylor distributor or service agency, will provide a new or remanufactured Part, at Taylor's option, to replace the failed defective Part at no charge for the Part. Except as otherwise stated herein, these are Taylor's exclusive obligations under this limited warranty for a Part failure. This limited warranty is subject to all provisions, conditions, limitations, and exclusions listed below and on the reverse (if any) of this document.

Table 11-1

Parts Warranty Class Code Or Part	Limited Warranty Period
Class 103 Parts ¹	Three (3) Months
Class 212 Parts ²	Twelve (12) Months
Class 512 Parts	Twelve (12) Months
Class 000 Parts	No Warranty

LIMITED WARRANTY CONDITIONS

1. If the date of original installation of the Part cannot be otherwise verified, proof of purchase may be required at time of service.
2. This limited warranty is valid only if the Part is installed and all required service work in connection with the Part is performed by an authorized Taylor distributor or service agency.
3. The limited warranty applies only to Parts remaining in use by their original owner at their original installation location in the machine of original installation.
4. Installation, use, care, and maintenance must be normal and in accordance with all instructions contained in the Taylor Operator's Manual.
5. Defective Parts must be returned to the authorized Taylor distributor or service agency for credit.
6. This warranty is not intended to shorten the length of any warranty coverage provided pursuant to a separate Taylor Limited Warranty on freezer or grill machine.
7. The use of any refrigerant other than that specified for the machine in which the Part is installed will void this limited warranty.

^{1, 2} Except that Taylor Part #032129SER2 (Compressor-Air-230V SERV) and Taylor Part #075506SER1 (Compressor-Air-115V 60HZ) shall have a limited warranty period of twelve (12) months when used in Taylor freezer machine and a limited warranty period of two (2) years when used in Taylor grill machine.

LIMITED WARRANTY ON PARTS

LIMITED WARRANTY EXCEPTIONS

This limited warranty does **not** cover:

1. Labor or other costs incurred for diagnosing, repairing, removing, installing, shipping, servicing, or handling of defective Parts, replacement Parts, or new Parts.
2. Normal maintenance, cleaning, and lubrication as outlined in the Taylor Operator's Manual, including cleaning of condensers or carbon and grease buildup.
3. Required service, whether cleaning or general repairs, to return the cooking surface assemblies, including the upper platen and lower plate, to an operational condition to achieve proper cooking or allow proper assembly of release sheets and clips as a result of grease buildup on the cooking surfaces, including but not limited to the platen and plate, sides of the shroud, or top of the shroud.
4. Replacement of cooking surfaces, including the upper platen and lower plate, due to pitting or corrosion (or in the case of the upper platen, due to loss of plating) as a result of damage due to the impact of spatulas or other small wares used during the cooking process or as a result of the use of cleaners, cleaning materials, or cleaning processes not approved for use by Taylor.
5. Replacement of wear items designated as Class "000" Parts in the Taylor Operator's Manual, as well as any release sheets and clips for the Product's upper platen assembly.
6. External hoses, electrical power supplies, and machine grounding.
7. Parts not supplied or designated by Taylor, or damages resulting from their use.
8. Return trips or waiting time required because a service technician is prevented from beginning warranty service work promptly upon arrival.
9. Failure, damage, or repairs due to faulty installation, misapplication, abuse, no or improper servicing, unauthorized alteration, or improper operation or use as indicated in the Taylor Operator's Manual, including but not limited to the failure to use proper assembly and cleaning techniques, tools, or approved cleaning supplies.
10. Failure, damage, or repairs due to theft, vandalism, wind, rain, flood, high water, water, lightning, earthquake, or any other natural disaster, fire, corrosive environments, insect or rodent infestation, or other casualty, accident or condition beyond the reasonable control of Taylor; operation above or below the gas, electrical, or water supply specification of the machine in which a part is installed; or Parts or the machines in which they are installed repaired or altered in any way so as, in the judgment of Taylor, to adversely affect performance, or normal wear or deterioration.
11. Any Part purchased over the Internet.
12. Failure to start due to voltage conditions, blown fuses, open circuit breakers, or damages due to the inadequacy or interruption of electrical service.
13. Electricity, gas, or other fuel costs, or increases in electricity or fuel costs from any reason whatsoever.
14. Damages resulting from the use of any refrigerant other than that specified for the machine in which the Part is installed will void this limited warranty.
15. Any cost to replace, refill, or dispose of refrigerant, including the cost of refrigerant.
16. **ANY SPECIAL, INDIRECT, OR CONSEQUENTIAL PROPERTY OR COMMERCIAL DAMAGE OF ANY NATURE WHATSOEVER.** Some jurisdictions do not allow the exclusion of incidental or consequential damages, so this limitation may not apply to you.

This limited warranty gives you specific legal rights, and you may also have other rights which vary from jurisdiction to jurisdiction.

LIMITATION OF WARRANTY

THIS LIMITED WARRANTY IS EXCLUSIVE AND IS IN LIEU OF ALL OTHER WARRANTIES, CONDITIONS, AND/OR REMEDIES UNDER THE LAW, INCLUDING ANY IMPLIED WARRANTIES OR CONDITIONS OF MERCHANTABILITY OR FITNESS FOR A PARTICULAR PURPOSE. THE ORIGINAL OWNER'S SOLE REMEDY WITH RESPECT TO ANY PRODUCTS SHALL BE REPAIR OR REPLACEMENT OF DEFECTIVE PARTS UNDER THE TERMS OF THIS LIMITED WARRANTY. ALL RIGHTS TO CONSEQUENTIAL OR INCIDENTAL DAMAGES (INCLUDING CLAIMS FOR LOST SALES, LOST PROFITS, PRODUCT LOSS, PROPERTY DAMAGES, OR SERVICE EXPENSES) ARE EXPRESSLY EXCLUDED. THE EXPRESS WARRANTIES MADE IN THIS LIMITED WARRANTY MAY NOT BE ALTERED, ENLARGED, OR CHANGED BY ANY DISTRIBUTOR, DEALER, OR OTHER PERSON, WHATSOEVER.

LEGAL REMEDIES

The owner **must** notify Taylor in writing, by certified or registered letter to the following address, of any defect or complaint with the Part, stating the defect or complaint and a specific request for repair, replacement, or other correction of the Part under warranty, mailed at least thirty (30) days before pursuing any legal rights or remedies.

Taylor Company
750 N. Blackhawk Blvd.
Rockton, IL 61072, U.S.A.

