

# Traulsen



**For All Full Size Undercounter, G-Series and R&A  
Refrigerator, Freezer, Dual-Temp and Hot Food  
Units**

**Traulsen**  
4401 Blue Mound Road Fort Worth, Texas  
76106 Phone: (800) - 825 - 8220

## Introduction

Traulsen provides this manual as an aid to the service technician in installation, operation and maintenance of Traulsen units from year 2010 to present. When used properly. This service manual can help the service technician maintain, troubleshoot and diagnose most of the problems and malfunctions that may occur with the controllers. While we believe that most aspects of the controllers are covered in this manual should you encounter a condition not addressed, or require a wiring diagram please contact.

ITW Refrigeration  
Traulsen  
4401 Blue Mound Road Fort Worth, TX 76106  
Attn: Service Department  
Phone: (800) 825-8220  
Fax: (817) 740-6757  
[Service@Traulsen.com](mailto:Service@Traulsen.com)

To improve your service communication experience be sure to have the following available when contacting technical support:

- ✓ Serial number
- ✓ Model number
- ✓ A detailed explanation of the problem.

### How to Read a Traulsen Serial Number

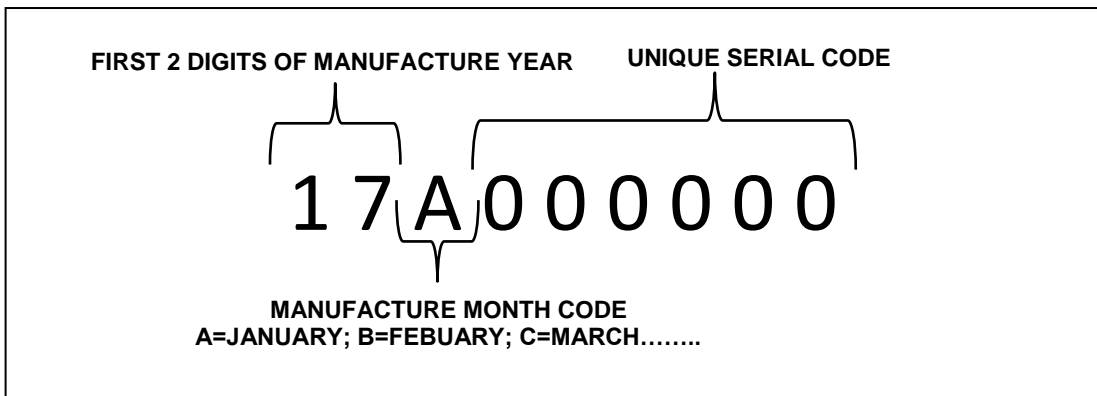
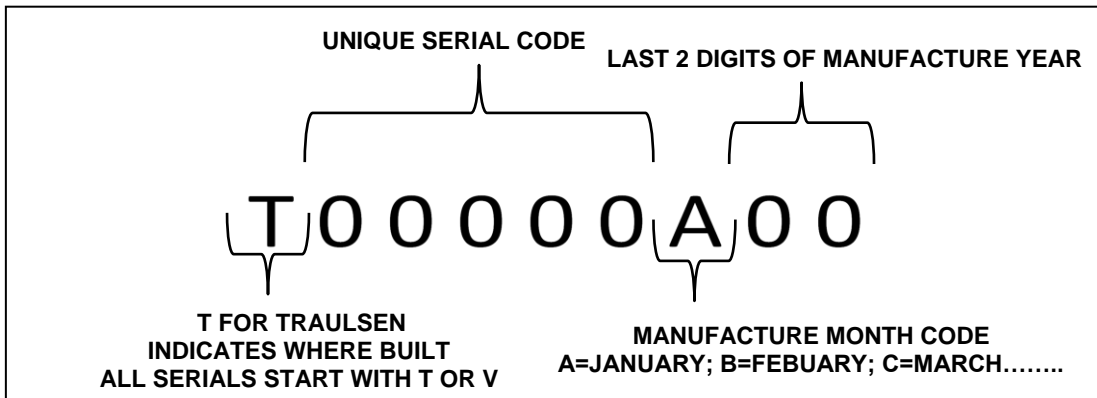

## TABLE OF CONTENTS

<b><u>Section I</u></b>	<b><u>Intela-Traul Control System</u></b>	<b><u>Page</u></b>
a.	Intela-Traul Control System Overview	4
b.	Intela-Traul Alarm Codes from 2010 to present	5
c.	Control Access & Programming	6
d.	Troubleshooting Traulsen Intela-Traul Sensors	7
e.	Troubleshooting Traulsen Intela-Traul MIT II relay module	10
f.	RH Sensor Module	12
<b><u>Section II</u></b>	<b><u>Refrigeration System</u></b>	
a.	Troubleshooting Traulsen Refrigeration System	14
b.	TXV Troubleshooting	15
c.	Troubleshooting a Frozen Evaporator Coil	16
d.	Compressor Troubleshooting	17
<b><u>Section III</u></b>	<b><u>Compact &amp; Milk Cooler Controls</u></b>	
a.	Danfoss Control Electronic Controller	20
b.	Danfoss Control Sensors	21
c.	Milk Cooler Temperature Checklist	22
<b><u>Section IV</u></b>	<b><u>Preventive Maintenance</u></b>	
a.	Preventive Maintenance	24
<b><u>Section V</u></b>	<b><u>Door Frame Heaters</u></b>	
a.	Door Frame Heater installation	27
b.	Door Frame Heaters in Roll-In units	30
c.	Door Frame Heaters in Half Height units	31
<b><u>Section VI</u></b>	<b><u>Wiring Diagrams</u></b>	
a.	G & R/A Series	33
b.	UHT Danfoss Series	34
c.	ULT Danfoss Series	35
d.	Milk Cooler Danfoss Series	36

**Section I**  
**Intela-Traul Control System**

## I. a – Inteltra-Traul Control System Overview

### Inteltra-Traul Components:

Component	Description
	<p><b>Control Head</b></p> <ul style="list-style-type: none"> <li>• Microprocessor Control</li> <li>• User Interface</li> </ul>
	<p><b>Relay Module</b></p> <ul style="list-style-type: none"> <li>• DC Power Supply</li> <li>• Blower Relay</li> <li>• Defrost Heater Relay</li> <li>• Door Frame Heater Relay</li> <li>• Supplies 12VDC to Compressor Relay</li> </ul>
	<p><b>Hybrid Relay</b></p> <ul style="list-style-type: none"> <li>• Hybrid Solid State Relay</li> <li>• Compressor/Condenser Relay</li> <li>• 12VDC Coil Voltage</li> </ul>
	<p><b>Sensors</b></p> <ul style="list-style-type: none"> <li>• Green – Cabinet Air</li> <li>• Blue – Evaporator Coil</li> <li>• Yellow – Liquid Line</li> </ul>

Table 1

### Basic Control Function:

Function	Component	Trigger
Cycles Door Frame Heaters	Door Frame Heaters	Based on Control Settings (will vary)
Cycles Evaporator Blower Motor	Evaporator Blower	Based on Control Settings (will vary)
Controls Defrost Cycle	Defrost Heater	Time Initiated, Terminated by Blue Evap Coil Sensor Temp
Cycles Refrigeration System	Refrigeration System	Green Cabinet Air Sensor Temp
Triggers Alarm/Trouble Code	Alarms	Based on Control Settings

Table 2

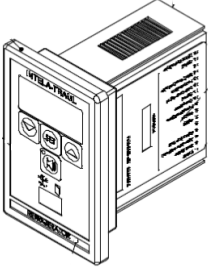
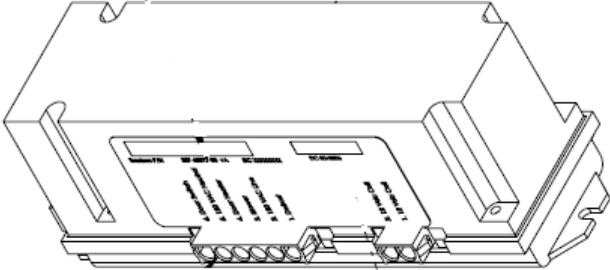
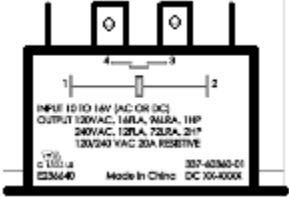
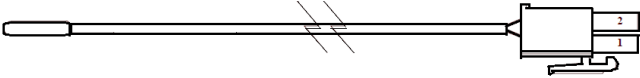
**I. b - Intela-Traul Alarm Codes from 2010 to present**

<b><u>Alarm</u></b>	<b><u>Description</u></b>	<b><u>Clear Alarm</u></b>
CAL SER	Refrigeration System Low Charge	Repair Refrigeration System
LO CAB	Low Cabinet Temperature Alarm	Return Cabinet Temperature to Normal Range
H I CAB	High Cabinet Temperature Alarm	Return Cabinet Temperature to Normal Range
door OPn	Door Open Alarm	Close Door
ELE LOS	Power Loss Alarm	Press Alarm Cancel
CLnFIL	Clean Condenser Alarm	Clear/Clean Condenser Coil
CoL Snr	Coil Sensor Open or Shorted	Replace Coil Sensor
CAB Snr	Cab Sensor Open or Shorted	Replace Cabinet Sensor
d IS Snr	Discharge Line Sensor open or shorted	Replace Discharge Line Sensor
def Err	Defrost Terminates by Time, Not Temperature, for 72 hours.	Troubleshoot Defrost Cycle
Snr 1	Cab Sensor Open or Shorted	Replace Cabinet Sensor
Snr 2	Coil Sensor Open or Shorted	Replace Coil Sensor
Snr 3	Liquid Line Sensor Open or Shorted	Replace Liquid Line Sensor
cLO	Low Cabinet Temperature Alarm	Return Cabinet Temperature to Normal Range
cHI	High Cabinet Temperature Alarm	Return Cabinet Temperature to Normal Range

Table 3

## I. c – Intela-Traul Control Access & Parameters

To access the engineering/service menu follow the instruction below. As seen in Figures 1 & 2.

INTELA-TRAUL Access		
<u>Press</u>	<u>Display</u>	<u>Press</u>
	0.5	
	6.5	
	0.00	
	9.00	
	9.90	
	9.9E	
	F0C	
If control does not have 		
	F0C	

Figure 1

INTELA-TRAUL Key Parameters	
<u>Parameter</u>	<u>Description</u>
SP	Set Point
SPd	Set Point Differential
SPH	Set Point High (Equip Prior to 2010 only)
SPL	Set Point Low (Equip Prior to 2010 only)
EL	Evaporator Coil Sensor Temp
Cb	Cabinet Air Sensor Temp
LL	Liquid Line Sensor Temp
Sd	Start Manual Defrost
Ibd	Intervals Between Defrost (In hours)
CdE	Defrost Termination Temperature
ddE	Drip Time After Defrost
ddC	Length of Defrost (In Minutes)
CEP	Reset to Factory Defaults

Figure 2

## I. d - Troubleshooting Traulsen Intela-Traul Sensors

### Sensor Function:

- **Cabinet Sensor (Green):** The Cabinet sensor reads the temperature of the return air and relays that value back to the control head. The control head either cycles the compressor on or off depending on the temperature set points. If cabinet sensor reads 60°F (15 °C) or higher the unit will not go into defrost and you can't put into manual defrost.
- **Coil Sensor (Blue):** The Coil sensor reads the evaporator coil core temperature and returns that value back to the control head. The control head uses this input to terminate the defrost cycle at 45°F (7.2°C) evaporator core temperature. In addition the control head uses the evaporator coil core temperature to control evaporator fan delay.
- **Liquid Line Sensor (Yellow):** The Liquid Line sensor reads the temperature of the liquid line and returns that value back to the control head. The control head uses the liquid line temperature to trigger a clean coil alarm at 140°F (60°C) (R&A series only) & cycles the compressor off on high temp limit at 160°F (71.1°C) liquid line temperature.

### Basic Troubleshooting:

All sensors (cabinet, coil, liquid line) can be tested for accuracy using a Volt Ohm Meter.

- When checking a sensor value through the control a reading of **-40°F (-40°C)** indicates an **open** in the sensor or sensor circuit and a reading of **266°F (130°C)** indicates a **short** in the sensor or sensor circuit. See **Table 4** for control head sensor parameters.
- An ice & water solution consisting of mostly ice with just enough water to submerge the sensor should be used to create a controlled environment of approximately 32°F (0°C). This solution likely needs to be agitated or stirred to maintain a consistent temperature throughout. At **32°F (0°C)** all sensors should return an Ohm reading of **32,000 Ohms +/- 10%**. See **Table 5** below for temperature & Ohms relationship of all Intela-Traul sensors.

Sensor	Parameter
Cabinet Air	CB
Evaporator Coil	EL
Liquid Line	LL

Table 4

TEMP (°F)	R (OHMS)	TEMP (°C)
20	46.2K Ω	-6.7
25	39.9K Ω	-3.9
30	34.6K Ω	-1.1
32	32.7K Ω	0.0
35	30.1K Ω	1.7
40	26.1K Ω	4.4

Table 5

## I. d - Troubleshooting Traulsen Intela-Traul Sensors

Quick Reference Table 6

Item	Details
Cabinet Sensor	<ul style="list-style-type: none"> <li>• Green</li> <li>• Control parameter <math>\square\square</math></li> <li>• Reads return air</li> <li>• Compressor cycles off of cabinet sensor value</li> <li>• If cabinet sensor reads 60°F (15 °C) or higher the unit will not go into defrost and you can't put into manual defrost.</li> </ul>
Coil Sensor	<ul style="list-style-type: none"> <li>• Blue</li> <li>• Control parameter <math>\square\square</math></li> <li>• Reads evaporator coil temperature</li> <li>• Terminates defrost</li> <li>• Temperature fan delay after defrost &amp; start up</li> </ul>
Liquid Line Sensor	<ul style="list-style-type: none"> <li>• Yellow</li> <li>• Control parameter <math>\square\square</math></li> <li>• Reads liquid line temperature</li> <li>• Triggers clean filter alarm @ 140°F (60°C) (R&amp;A Series Only)</li> <li>• Compressor safety; Cycles compressor off @ 160°F (7.1°C)</li> </ul>
Sensor Open	<ul style="list-style-type: none"> <li>• -40°F (-40°C)</li> </ul>
Sensor Short	<ul style="list-style-type: none"> <li>• 266°F (130°C)</li> </ul>
Sensor can fail anywhere	<ul style="list-style-type: none"> <li>• Between -40 &amp; + 266 (-40°F &amp; (130°C)</li> </ul>
Sensor Test	<ul style="list-style-type: none"> <li>• 32K <math>\Omega</math> @ 32°F (0°C)</li> </ul>
Alarm Codes (R&A Series Only)	<ul style="list-style-type: none"> <li>• <math>\square\square\square\square</math> Open or shorted cabinet sensor</li> <li>• <math>\square\square</math> Open or shorted cabinet sensor</li> <li>• <math>\square\square\square\square</math> Open or shorted evaporator coil sensor</li> <li>• <math>\square\square</math> Open or shorted evaporator coil sensor</li> <li>• <math>\square\square\square\square</math> Open or shorted liquid line sensor</li> <li>• <math>\square\square</math> Open or shorted liquid line sensor</li> </ul>

Table 6

## I. d - Troubleshooting Traulsen Intela-Traul Sensors

### Advanced Trouble Shooting Tips

There are a variety of reasons for the symptoms listed in **Table 7**. This troubleshooting table is intended to address the most common reasons associated with the Intela-Traul sensors only. Further troubleshooting outside the scope of this document may be required.

Symptom	Possible Causes
Cabinet temperature display reads lower temperature than actual cabinet temperature	<ul style="list-style-type: none"> <li>• Evaporator coil is frozen up</li> <li>• Defective cabinet sensor</li> <li>• Cabinet sensor not in proper location</li> </ul>
Cabinet temperature display reads higher temperature than actual cabinet temperature	<ul style="list-style-type: none"> <li>• Defective cabinet sensor</li> <li>• Air flow obstruction</li> <li>• Cabinet sensor not in proper location</li> </ul>
Evaporator coil is frozen up	<ul style="list-style-type: none"> <li>• Evaporator coil sensor is out of tolerance and terminating defrost to soon</li> <li>• Cabinet air sensor is out of tolerance causing cabinet air temp to run too low</li> </ul>
Display temperature reads -40°F (-40°C)	<ul style="list-style-type: none"> <li>• Cabinet sensor is open</li> <li>• Cabinet sensor is disconnected</li> <li>• Cabinet sensor wire harness is open</li> <li>• Cabinet sensor pin connector is loose or has a weak connection</li> </ul>
Compressor cycles off before cabinet temperature is satisfied	<ul style="list-style-type: none"> <li>• Liquid line sensor is out of tolerance and return to high of a temperature causing the compressor to cycle off</li> <li>• Liquid line is reaching 160°F (71.1°C) and cycling the compressor off on high temp limit</li> </ul>

Table 7

## I. e - Troubleshooting Traulsen Intela-Traul MIT II Relay Module

### Relay Module Function:

The Traulsen Relay Module is a long black rectangular box approximately 2 x 2 x 7 inches (5.08 X 5.08 X 17.08 centimeters) located behind the controller (front panel display) that contains several switching relays. The relays inside the module are used to send line voltage to the compressor (or heaters if a Hot Food box) fan motor(s), or defrost heaters or defrost solenoids, as needed. The actuation of these relays is controlled by low voltage DC signals sent from the Intela-Traul™ Control.

### Relay Module Architecture:

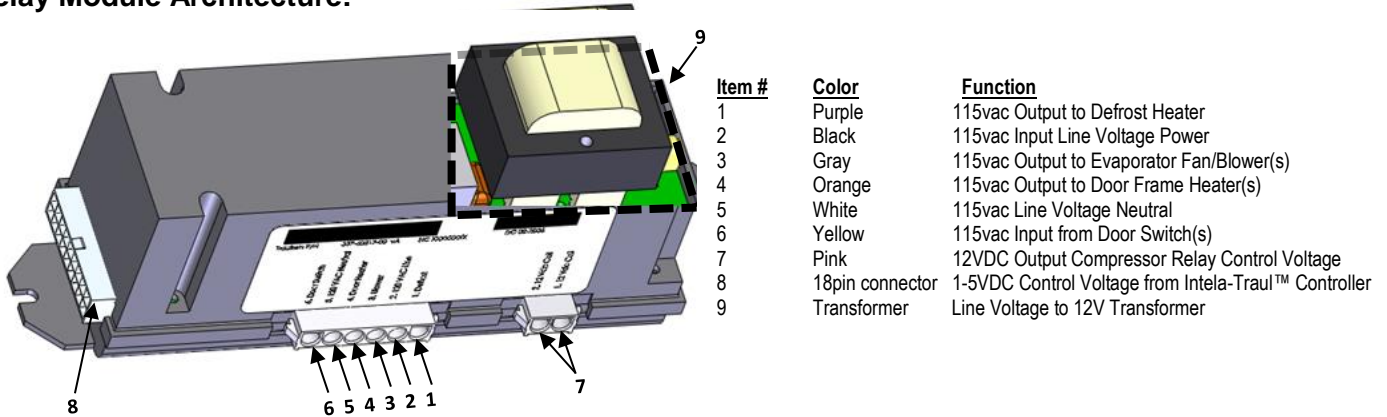

Figure 3

**Note:** Items 1, 3, & 4 are equipped with snubber circuits to reduce arcing and increase relay life. As result Line Voltage will always be measured at the relay output regardless of relay state, open/closed.

### Relay Module Control Voltage:



**WARNING** Certain procedures in this section require electrical test or measurements while power is applied to the machine. Exercise extreme caution at all times. If test points are not easily accessible, disconnect power and follow lockout / tagout procedures, attach test equipment and reapply power to test.

Relay control voltage is checked at the 18pin connector which delivers a range of 1-5VDC to the relay module when the control is calling for a relay to be energized. **When checking for relay control voltage the 18pin connector MUST remain connected.**

## I. e - Troubleshooting Traulsen Intela-Traul MIT II Relay Module

### Relay Module Control Voltage (Cont):



Pin No.	Color	Signal
1	Gray	Blower
2	Orange	Door Heater
3	Green	Alarm From Controller
4	Black	Return to Horn
5		Unused
6		Unused
7	White/Purple	-RS485
8	Black	Ground
9	White	12vac
10	Blue	Compressor
11	Purple	Defrost
12	Yellow	Door Open Signal
13	Red	Power to Horn
14		Unused
15		Unused
16	Pink	+RS485
17	Red	12 VDC Controller Power
18	Black	12vac

Figure 4

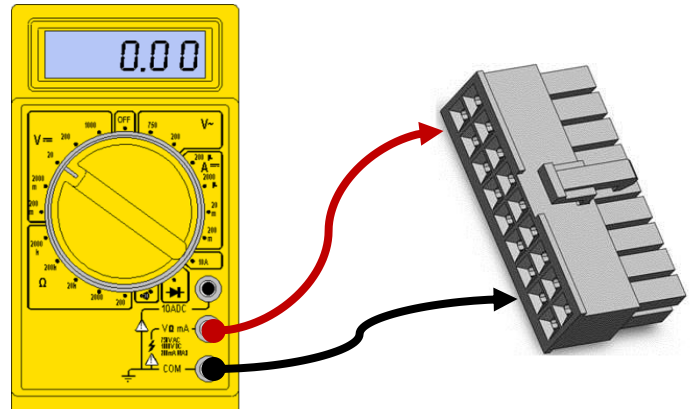

Check control voltage by inserting meter leads into the back of the 18pin connector at the appropriate points. **18pin connector must be connected to the relay module.**

### Relay Module Output Voltage:



**WARNING** Certain procedures in this section require electrical test or measurements while power is applied to the machine. Exercise extreme caution at all times. If test points are not easily accessible, disconnect power and follow lockout / tagout procedures, attach test equipment and reapply power to test.

If the 1-5VDC control voltage from the Intela-Traul™ has been confirmed but the corresponding component is not energized output voltage from the relay module needs to be confirmed. The simplest way to confirm whether or not the relay inside the relay module has failed is to jump out the relay contacts. You can do this by unplugging the six pin connector and jump pin 2 (Black, 115vac input) to the corresponding output pin. If the component energizes then the relay module likely needs to be replaced. If the component still does not energize then further troubleshooting of the component is needed.

## I. f - RH Sensor Module

The Inteltra-Traul RH module (Relative Humidity Sensor) is found on the Traulsen Energy Star rated units, from October 2014 to the present. This technical bulletin may not cover all the situations that may arise in the field and final diagnosis of field based equipment is the sole responsibility of the technician contracted to perform any work required.

### Functionality:

The RH module senses the ambient temperature and relative humidity and communicates the information to the MIT II control. The MIT II control uses this data to perform the following tasks. As seen in **Table 8**.

- Cycle the door heater based on ambient temperature and humidity conditions.
- Increase/decrease the intervals between defrosts based on the number of door open/close events and the ambient temperature conditions. + or -75%.

### Parameters Table:



Displayed	Parameter Name	Sample Value	Description
	Relative Humidity (Ambient)	55.0	Relative humidity of the room.
	Dry Bulb Temperature	75.0	Ambient temperature of the room.
	Dew Point Temperature	65.0	Calculated dew point temperature.

Table 8

### Troubleshooting Table:

Symptom	Possible cause	Solution
Excessive condensation on the door.	Inaccurate reading from the RH module.	Unplug RH sensor. Replace the RH sensor module.
Coil freezes up.	The RH module extends the interval between defrost based on ambient conditions.	Unplug RH sensor. Put unit into manual defrost. Replace RH sensor.

Table 9

**Note:** You can disconnect the RH Sensor and the unit will run with its default settings.

**Section II**  
**Refrigeration System**

## II. a - Troubleshooting Traulsen Refrigeration System

### Introduction:

This is to inform the field how to trouble shoots the refrigeration system with the use of a thermometer. As seen in **Figure 5**.

### Trouble Shooting Refrigeration System by Temperature:

Use **Table 10** and corresponding chart (**Figure 5**) to aid in troubleshooting a Traulsen refrigeration system with the use of thermometers.

ITEM	FORMULA	TRAULSEN SPEC
Condenser Split	$(A + B)/2 - \text{Ambient Temperature}$	30°F (-1.1°C)
Sub-cooling	$(A + B)/2 - B$	4°F to 12°F (-15.5°C -11.1°C)
Evaporator Superheat	D-C	5°F to 7°F (-15°C to 13.9°C)

Table 10

**Note:** Unit must be running for at least 5-10 minutes before checking temperatures and insulate sensing bulb of thermometer for most accurate readings.

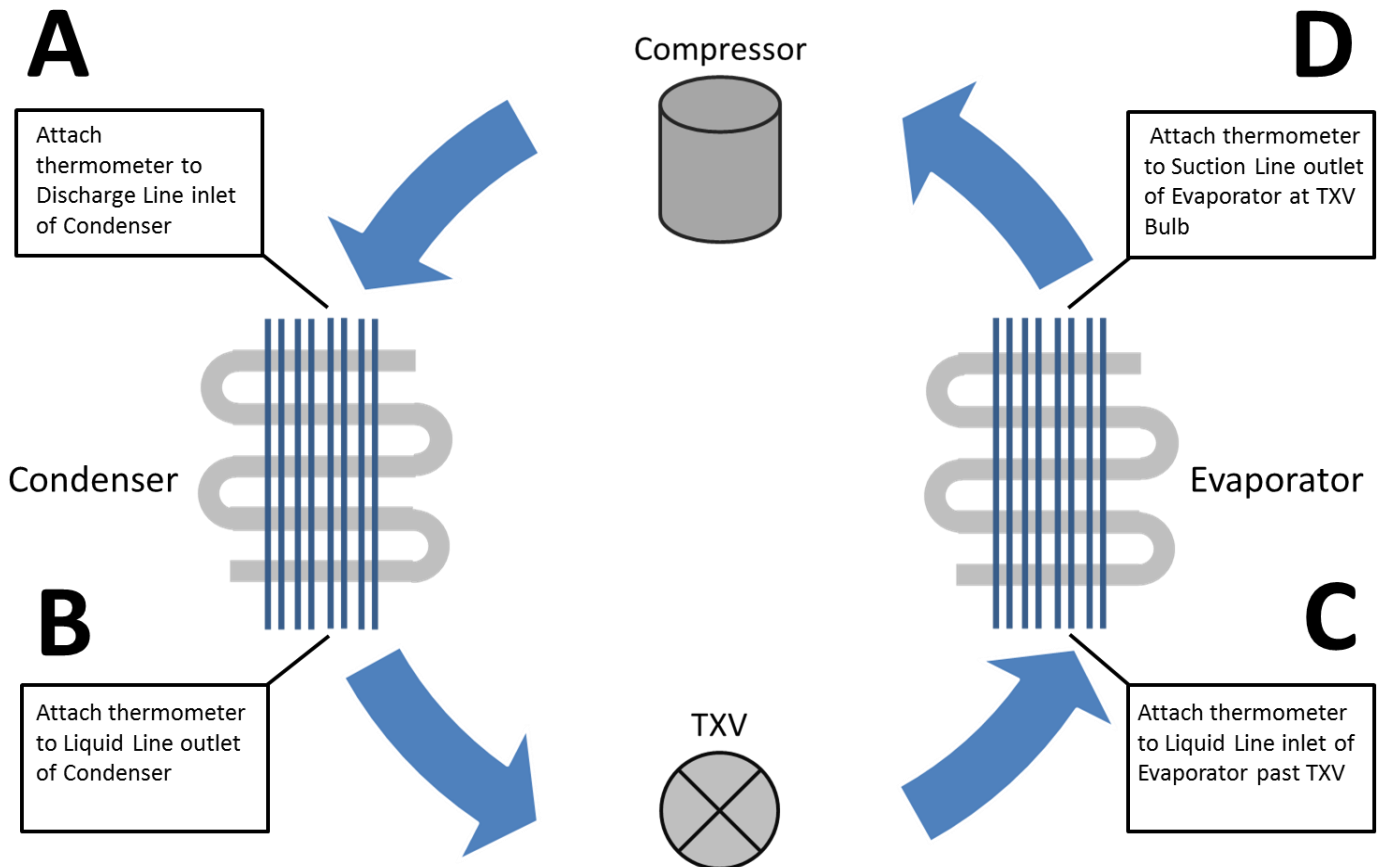

Figure 5

## II. b - TXV Troubleshooting

### Standard Operating Parameters: (As measured in Figure 5, Page 14)

- Superheat – 7°F (-13.9°C)
- Subcooling – 4°F-12°F (-15.5°C TO -11.1°C)

### Troubleshooting:

**⚠ WARNING** This procedure requires the use of refrigerants. Be certain the work area is well ventilated. Safety goggles and gloves shall be worn since refrigerants may cause burns to the skin

**⚠ WARNING** Do not pressurize system above 150 PSIG prior to evacuation or durring leak test procedures.

Superheat	Subcooling	Diagnosis
Above 7F	Below 4F	Refrigerant Charge is Low
Below 5F	Above 12F	System Overcharged
Above 7F	Above 12F	Restriction in High Side or Metering Device

Table 11

### Moisture Contamination:

A restriction caused by moisture will thaw when the TXV is warmed and the system will begin to function properly until the moisture finds its way back to the TXV and freezes at the orifice again. See **Table 11**.

## II. c - Troubleshooting a Frozen Evaporator Coil

**Table 12** is intended to aid in diagnosing the root cause of a frozen evaporator coil on a Traulsen upright reach-in refrigerator or freezer. This may not cover all situations that may arise in the field and final diagnosis of field based equipment is the sole responsibility of the technician contracted to perform any work required.

**Frozen Evaporator Troubleshooting Table**

Potential Causes	Details
Cabinet Sensor out of tolerance (See TTB006 Sensors for sensor troubleshooting)	<ul style="list-style-type: none"> <li>• Color: Green</li> <li>• Control parameter <math>\bar{C}b</math></li> <li>• Reads return air</li> <li>• Compressor cycles off of cabinet sensor value</li> </ul>
Coil Sensor out of tolerance (See TTB006 Sensors for sensor troubleshooting)	<ul style="list-style-type: none"> <li>• Color: Blue</li> <li>• Control parameter <math>\bar{E}L</math></li> <li>• Reads evaporator coil temperature</li> <li>• Terminates defrost @ 45°F (7.2°C)</li> <li>• Fan delay</li> </ul>
Ambient Air Infiltration	<ul style="list-style-type: none"> <li>• Door(s) not closing properly</li> <li>• Gasket(s) not sealing properly</li> <li>• Door(s) left open for extended periods of time</li> <li>• Evaporator hump cover not sealed properly</li> </ul>
Compressor relay stuck closed	<ul style="list-style-type: none"> <li>• Coil voltage 12VDC</li> <li>• Coil wires: Pink</li> <li>• Contacts <ul style="list-style-type: none"> <li>○ Common: Black wire</li> <li>○ N/O: Blue wire</li> </ul> </li> </ul>
Lack of Air Flow	<ul style="list-style-type: none"> <li>• Evaporator fan motor not functioning</li> <li>• Obstruction in air duct or at evaporator coil</li> </ul>
Refrigeration System (Traulsen recommends the refrigeration system be tested using the methods outlined in TTB009)	<ul style="list-style-type: none"> <li>• Low charge</li> <li>• Restricted metering device</li> <li>• Moisture/contaminates in the system</li> </ul>
Defrost Heater	<ul style="list-style-type: none"> <li>• Defrost heater open</li> <li>• Defrost heater circuit or relay open</li> </ul>
Control Settings	<ul style="list-style-type: none"> <li>• Set point to low (refrigerator only) <ul style="list-style-type: none"> <li>○ Control parameters: <math>\bar{S}P</math> or <math>\bar{S}PH</math> &amp; <math>\bar{S}PL</math> (depending on the age of control system)</li> </ul> </li> <li>• Defrost lockouts set to frequently <ul style="list-style-type: none"> <li>○ Control parameters: <math>\bar{d}L1, \bar{d}L2, \bar{d}L3, \bar{d}L4</math></li> </ul> </li> </ul>

**Table 12**

## II. d - Compressor Troubleshooting



**⚠ WARNING** Certain procedures in this section require electrical test or measurements while power is applied to the machine. Exercise extreme caution at all times. If test points are not easily accessible, disconnect power and follow lockout / tagout procedures, attach test equipment and reapply power to test.

### Tools Required:

- Basic hand tools
- Clamp around amp meter
- Volt Ohm meter
- Basic 3 in 1(1/2 HP)

### Terminology:

- **OEM** – Original Equipment Manufacturer – Refers to the manufacturer of a piece of equipment or component.
- **RLA** – Rated Load Amps – The OEM test conditions amperage rating (does not necessarily indicate the normal running amperage as conditions and applications can vary from OEM test conditions)
- **LRA** – Locked Rotor Amps – The OEM test condition lock rotor amperage rating indicating the expected amperage at which a motor does not turn when power is applied.
- **Start Components** – The capacitor and relay combinations used to start and/or run a compressor motor consist of a start capacitor and start relay if IAA is shown on the serial number of the compressor. If CAA is listed then there will be a potential relay along with a start capacitor and a run capacitor.

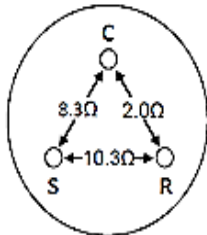

Example  
Figure 6

Ω= OHM= Unit Resistance  
R= Run  
S= Start  
C= Common

**Figure 6** shows the readings of the resistance through the compressor motor windings. (C-S C-R). If the windings are good the start winding resistance (C-S) will always be higher than the run winding resistance (C-R).

**Note:** This example shows one set of possible combinations that can be seen in the field. Resistance values will vary between different compressors.

## II. d - Compressor Troubleshooting

### Basic Troubleshooting:

- What is my amp draw and voltage when the compressor is starting?
- What is the resistance of the windings?
- What is the RLA (Rated Load Amps) of the compressor?
- What is the LRA (Locked Rotor Amps) of the compressor?
- Check the start components?

Symptom	Reason	Possible Resolution
0 amps	Check for voltage between C & R terminals.	No: Check external overload & find where power loss is. Yes: open winding or the internal overload is open
Amps lower then RLA	Lower head & high suction.	Weak valves, busted crankshaft or connecting rod.
Slightly higher amps then RLA	Overload opens after compressor runs for a time.	Bad run capacitor, tight bearings, or winding issues.
Very high amps but not LRA	Issue with compressor windings.	Ohm windings and compare with manufacturer's resistances.
Reading LRA	Compressor not starting, reading 5 to 6 times RLA.	Check start capacitor, start relay & wires for burning, try 3 in 1. Check voltage drop (+/-10%) and for resistance.

Table 13

**Section III**  
**Compact & Milk Cooler Controls**

### III. a - Danfoss Control Parameters

See corresponding tables below for Danfoss Control Parameters

#### Danfoss control parameters:

##### COMPACT FREEZER (ULT)

SET POINT RANGE:	-10F(-23C) to +5F(-15)
SET POINT:	-3F(-3C)
DEFROST TYPE:	ELECTRIC
DEFROST TERM:	35F(1C)
MIN DEF INTERVAL:	3.0 HOURS
MAX DEF INTERVAL:	4.0 HOURS
DEFROST TIME:	15 MIN MINIMUM 35 MIN MIAXIMUM
<b>COMPRESSOR ON:</b>	
FAN ON DELAY;	30 SEC
<b>COMPRESSOR OFF:</b>	
FAN OFF DELAY:	0.0 SEC
FAN ON:	5 SEC
FAN OFF:	55 SEC
DEFROST:	EVAP FAN OFF
DRIP OFF TIME:	1 MIN
FAN DELAY AFTER DEF:	3 MIN

Table 13

##### MILK COOLER

SET POINT RANGE:	30F(-1C) to 38F(3C)
SET POINT:	32.0 F
DEFROST TYPE:	OFF CYCLE
DEFROST TERM:	39F(3C)
MIN DEF INTERVAL:	2 HOURS
MAX DEF INTERVAL:	3 HOURS
DEFROST TIME:	20 MIN MINIMUM 45 MIN MAXIMUM
<b>COMPRESSOR ON:</b>	
FAN ON DELAY;	30 SEC
<b>COMPRESSOR OFF:</b>	
FAN OFF DELAY:	45 SEC
FAN ON:	5 SEC
FAN OFF:	55 SEC
DEFROST:	EVAP FAN ON
DRIP OFF TIME:	0.0 SEC
FAN DELAY AFTER DEF:	0.0 SEC

Table 15

##### COMPACT REFRIGERATOR (UHT)

SET POINT RANGE:	29F(-1C) to 37F(2C)
SET POINT:	32F(0C)
DEFROST TYPE:	OFF CYCLE
DEFROST TERM:	39F(3C)
MIN DEF INTERVAL:	2 HOURS
MAX DEF INTERVAL:	3 HOURS
DEFROST TIME:	20 MIN MINIMUM 45 MIN MAXIMUM
<b>COMPRESSOR ON:</b>	
FAN ON DELAY;	30 SEC
<b>COMPRESSOR OFF:</b>	
FAN OFF DELAY:	45 SEC
FAN ON:	5 SEC
FAN OFF:	55 SEC
DEFROST:	EVAP FAN ON
DRIP OFF TIME:	0.0 SEC
FAN DELAY AFTER DEF:	0.0 SEC

Table 14

##### PREP TABLE (UPT & UST)

SET POINT RANGE:	29F(-1C) to 37F(2C)
SET POINT:	32F(0C)
DEFROST TYPE:	OFF CYCLE
DEFROST TERM:	39F(0C)
MIN DEF INTERVAL:	2 HOURS
MAX DEF INTERVAL:	3 HOURS
DEFROST TIME:	20 MIN MINIMUM 45 MIN MAXIMUM
<b>COMPRESSOR ON:</b>	
FAN ON DELAY;	EVAP FAN ALWAYS ON
<b>COMPRESSOR OFF:</b>	
FAN OFF DELAY:	EVAP FAN ALWAYS ON
FAN ON:	EVAP FAN ALWAYS ON
FAN OFF:	EVAP FAN ALWAYS ON
DEFROST:	EVAP FAN ALWAYS ON
DRIP OFF TIME:	EVAP FAN ALWAYS ON
FAN DELAY AFTER DEF:	EVAP FAN ALWAYS ON

Table 16

### III. b - Danfoss Control Troubleshooting

#### DANFOSS SENSOR OHM VALUES

Sensor	Temperature	Ohm value
Cabinet sensor (S1)	32°F (0°C)	16.00 Ω
Coil Sensor (S2)	32°F (0°C)	16.00 Ω
Spindle (S3)	N/A	4-26 Ω (slight tolerance)

Table 17

**Note:** If the red light starts flashing this indicates a sensor failure.

#### To start manual defrost:

1. Turn unit off and make sure the spindle is all the way in the left position.
2. Turn unit on and wait for the blower to come on.
3. Turn spindle all the way to the right position for 3 seconds.
4. Turn spindle all the way to the left position for 3 seconds.
5. Turn to the middle position and wait for unit to go into manual defrost.



**⚠ WARNING** Certain procedures in this section require electrical test or measurements while power is applied to the machine. Exercise extreme caution at all times. If test points are not easily accessible, disconnect power and follow lockout / tagout procedures, attach test equipment and reapply power to test.

#### Troubleshooting Table:

Potential Causes	Possible Solutions
Faulty Danfoss control	<ul style="list-style-type: none"> <li>• See page 18 for Danfoss parameters.</li> </ul>
Faulty defrost termination	<ul style="list-style-type: none"> <li>• Check to make sure the defrost termination is not stuck open.</li> </ul>
Faulty coil sensor	<ul style="list-style-type: none"> <li>• If the coil sensor is faulty the unit will not go into its manual defrost. If either cabinet or coil sensors faulty the indicator light on top of the controller will be blinking red. Place the sensor in a glass of 32°F (0°C) ice water. Ohm sensor and you should get 16 K ohms.</li> </ul>

Table 18

### III. c - Milk Cooler Temperature Checklist

This is to inform the field of basic operational check points related to temperature maintenance concerns to understand prior to troubleshooting the refrigeration system function.

#### Troubleshooting checklist

- ✓ What is the walk-in cooler/milk storage cooler temp?



33F (1C) 36F (2C) 39F (4C) 41F (5C)

- ✓ What is the temperature of the milk before it is put into the milk cooler for serving ?



33F (1C) 36F (2C) 39F (4C) 41F (5C)

- ✓ How long is the serving period?



(Recommend Doors Closed for at Least 15min for Every 2 hours of Operation.)

- ✓ What is the ambient air temperature around the unit?



70F (21C) 80F (26C) 90F (32C) 100F (37C)

- ✓ Are there any significant sources of heat around the unit?
- ✓ Is there HVAC ventilation directly above the unit or other sources of forced air circulation that may be disrupting the air flow of the milk cooler?
- ✓ With door closed how fast does unit pull down to temperature?  
(Depending on the Milk Cooler footprint & loading, it will typically take 15-20 min for the unit to pull down and cycle.)
- ✓ Is the milk rotated? If so how often?  
(Recommend product is rotated every 2 hours.)

**Section IV**  
**Preventive Maintenance**

#### IV. a - Preventative Maintenance

##### Introduction:

This is to inform field of recommended preventative maintenance procedures. Depending on application PM schedule may vary.

### INSPECT AND CLEAN

<b>Why</b>	Sanitation and prolong cabinet life	
<b>Frequency</b>	Daily	
<b>Time required</b>	5 minutes to prepare	10 minutes to complete
<b>Preparation</b>	Have a Soft Cloth. Baking soda and water mixed to a 1 TBSP (15mL) baking soda to 1 pint (473.2mL) water ratio.	
<b>Cleaning</b>	Apply with a dampened cloth and wipe in the direction of the metal grain. (Avoid the use of strong detergents and gritty, abrasive cleaners as they may tend to mar and scratch the surface. Do NOT use cleansers containing chlorine; this may promote corrosion of the stainless steel.)	
<b>Inspection</b>	Visually inspect the unit for signs of wear that may require repair.	

Table 19

### INSPECT DOOR GASKET

<b>Why</b>	Long reliable service life	
<b>Frequency</b>	Every 3 Months	
<b>Time required</b>	10 minutes to complete	
<b>Inspection</b>	Open cabinet door (s) to inspect gasket. Pull gasket with hand and visually inspect gasket (s) for tear, dirt, mold or worn gasket. Replace as needed. The model and serial number is required when placing a parts order call the Traulsen Parts Department at 800-825-8220.	

Table 20

IV. a - Preventative Maintenance

**CLEAN CONDENSER COIL**

**⚠ WARNING** Disconnect electrical power supply before cleaning any parts of the unit.

<b>Why</b>	Long reliable service life	
<b>Frequency</b>	Every 3 Months	
<b>Time required</b>	5 minutes to prepare	15 minutes to complete
<b>Preparation</b>	<p>For All Upright Cabinets, remove the two bottom screws securing the louver panel, and then pivot this upwards allowing full access to the front facing condenser. For all TE Series, TU Series &amp; TS Series, place hands under the louver panel and pull out and up to get louver panel off bracket of the unit.</p> <div style="display: flex; justify-content: space-around; align-items: flex-start;"> <div style="text-align: center;"> <p><b>R &amp; A Series/G Series Louver</b></p>  </div> <div style="text-align: center;"> <p><b>TE/TU/TS Series Louver</b></p>  </div> </div>	
<b>Cleaning</b>	<p>Vacuum or brush any dirt, lint or dust from the finned condenser coil, around the compressor and other cooling system parts as indicated. If significant dirt is clogging the condenser fins, use compressed air to blow this clear. When finished reverse the louver removal process as instructed above.</p>	

Table 21

## **Section VI**

### **Door Frame Heater installation**

## VI. a - Door Frame Heater Replacement

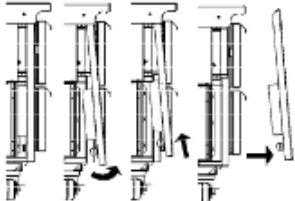

**⚠ WARNING** Certain procedures in this section require electrical test or measurements while power is applied to the machine. Exercise extreme caution at all times. If test points are not easily accessible, disconnect power and follow lockout / tagout procedures, attach test equipment and reapply power to test.

### Installation process:

*Note: The original heater wire will be abandoned in the foam.*

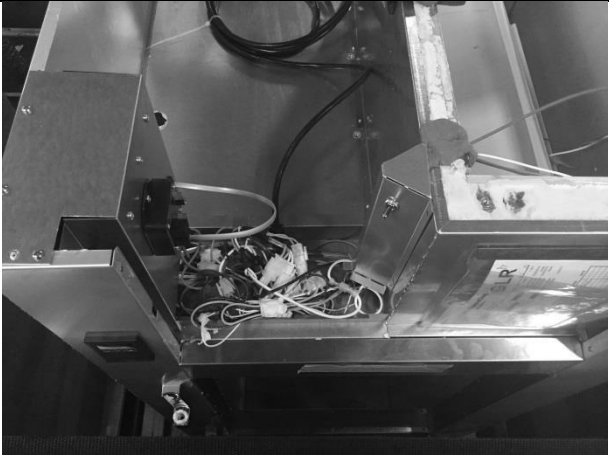
<ul style="list-style-type: none"><li>● Unplug unit.</li></ul>	
<ul style="list-style-type: none"><li>● Remove screws and breaker strips around the perimeter of the door opening. As seen in Figure 6.</li></ul>	 <p>Figure 6</p>
<ul style="list-style-type: none"><li>● Find the orange and white power supply wires to the door heaters on top of the unit in the wire chase. As seen in Figure 7.</li></ul>	 <p>Figure 7</p>

- Use a long probe or screw driver to create a hole through the foam in the top center mullion area up to the wire chase hole. As seen In Figure 8.



Figure 8

- In the wire chase check for the white and orange wires coming from the relay module. Connect the new heater wires to the power wires. As seen in Figure 9.

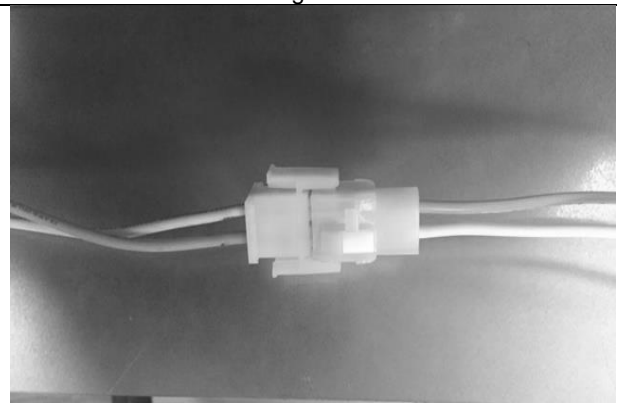

Figure 9

- Stick new foil heater wires around the perimeter of the unit to the right of the breaker strip screws closest to the outer skin of the unit as seen in Figure 10. Dig some foam out of each corner so the heater forms to the corner, to avoid pinching when reinstalling breaker strips.
- Re-foam.

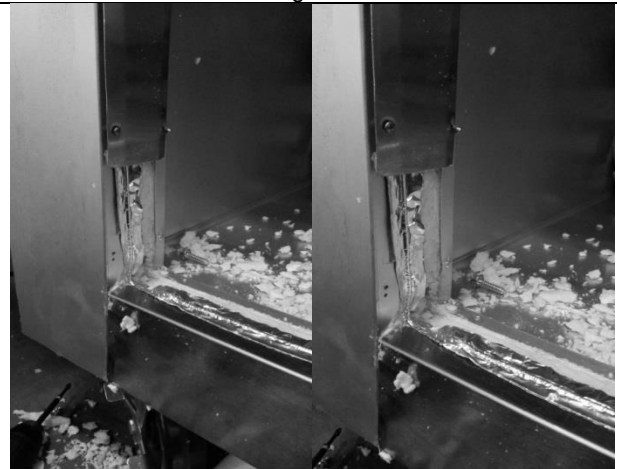

Figure 10

- When finished reinstall breakers strips.  
As seen in Figure 11.



Figure 11

- Plug in unit.

**VI. b - Door Frame Heaters in Roll-In Units**

In **Figure 12** How door frame heaters should be run in a two section Roll-in unit.

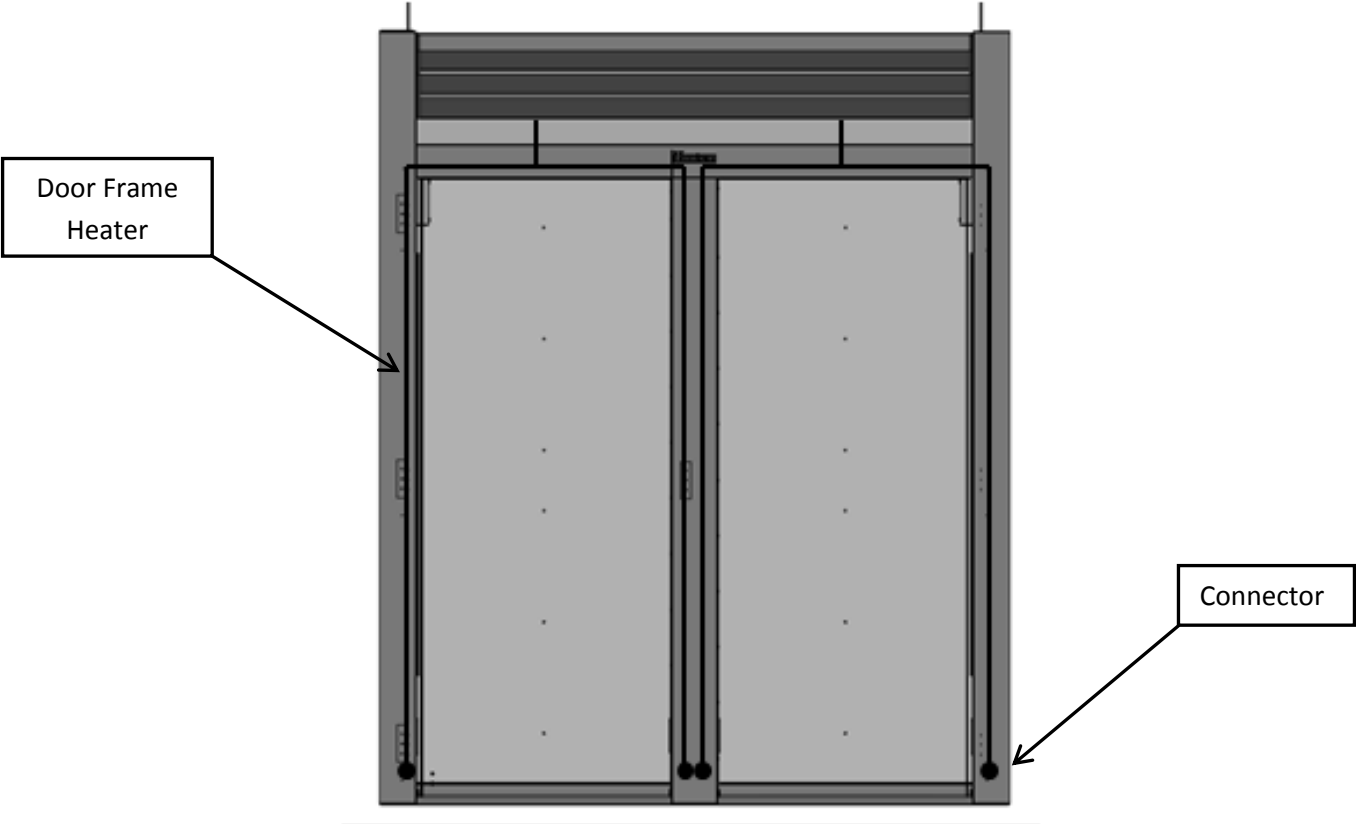

Figure 12

**VI. c - Door Frame Heaters in Half Height Units**

In **Figure 13** How door frame heaters should be run in a Half Height unit.

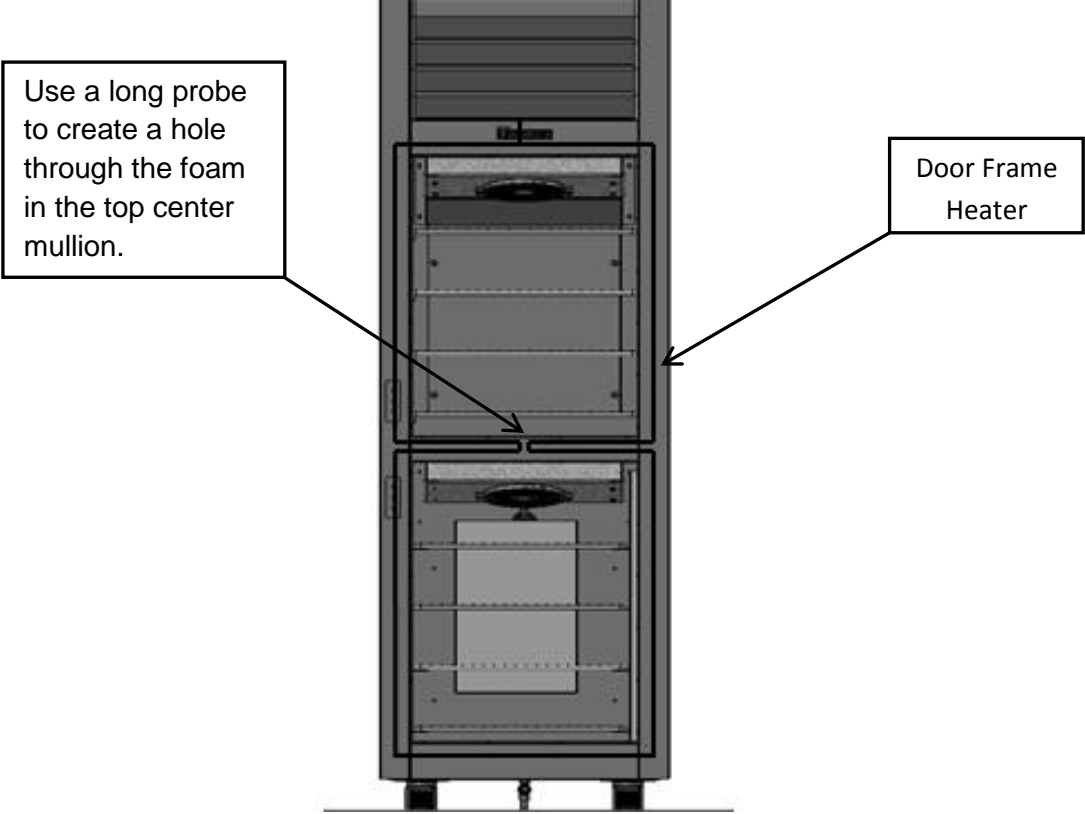
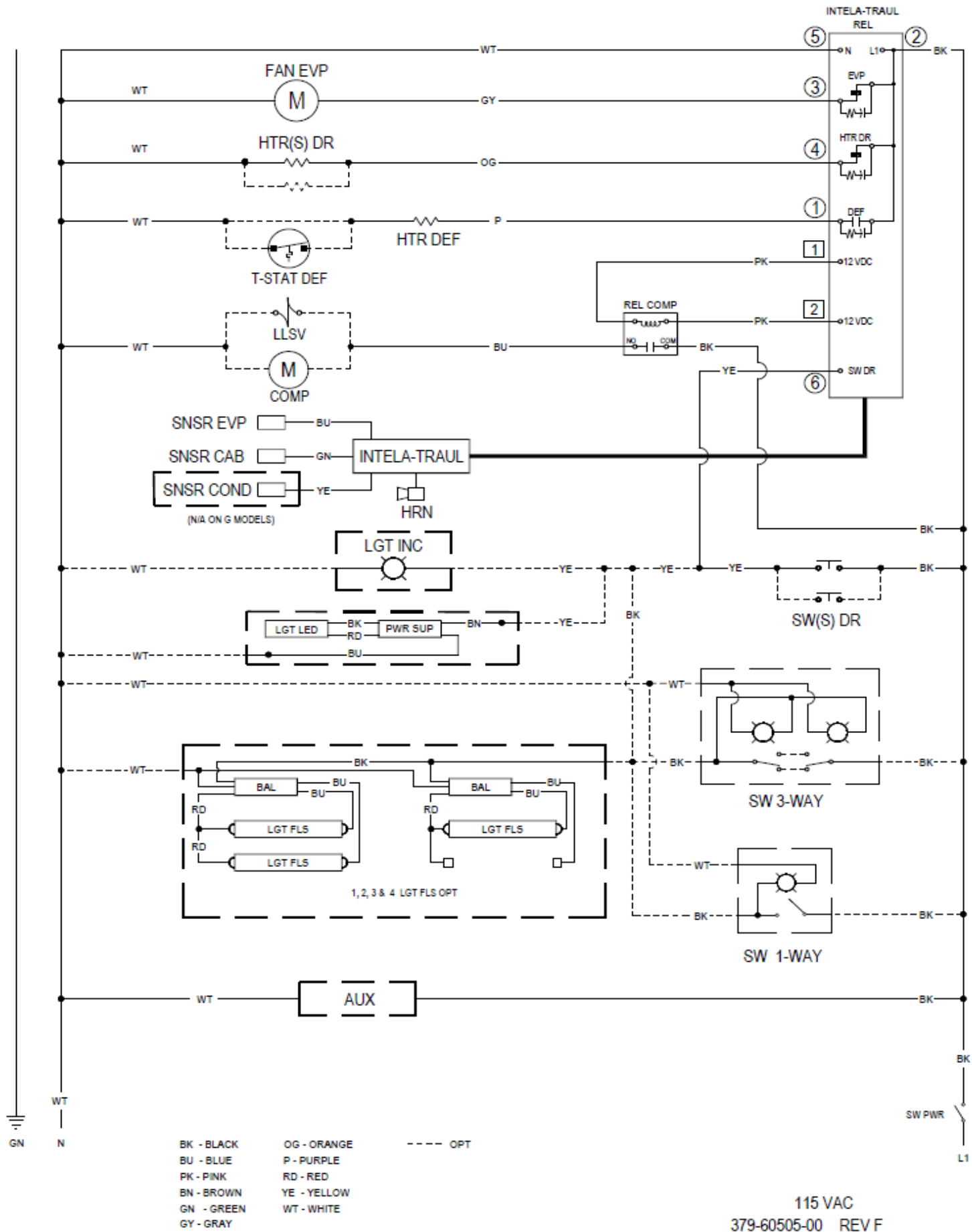

Figure 13

**Section VII**  
**General Wiring Diagrams**

# VII. a – G/R/A Series Reach-In



## VII. b - UHT Danfoss Series

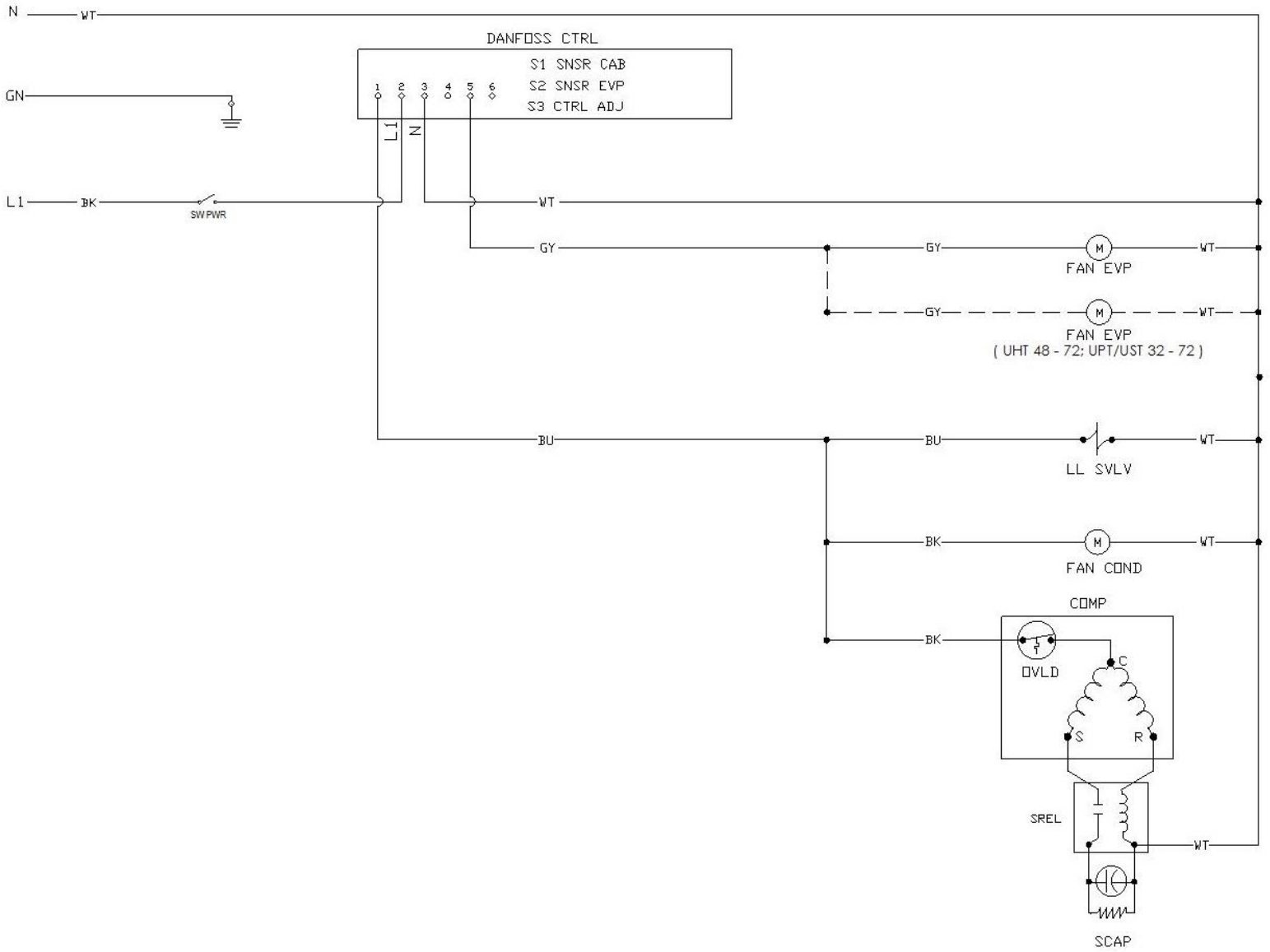

## VII. c - ULT Danfoss Series

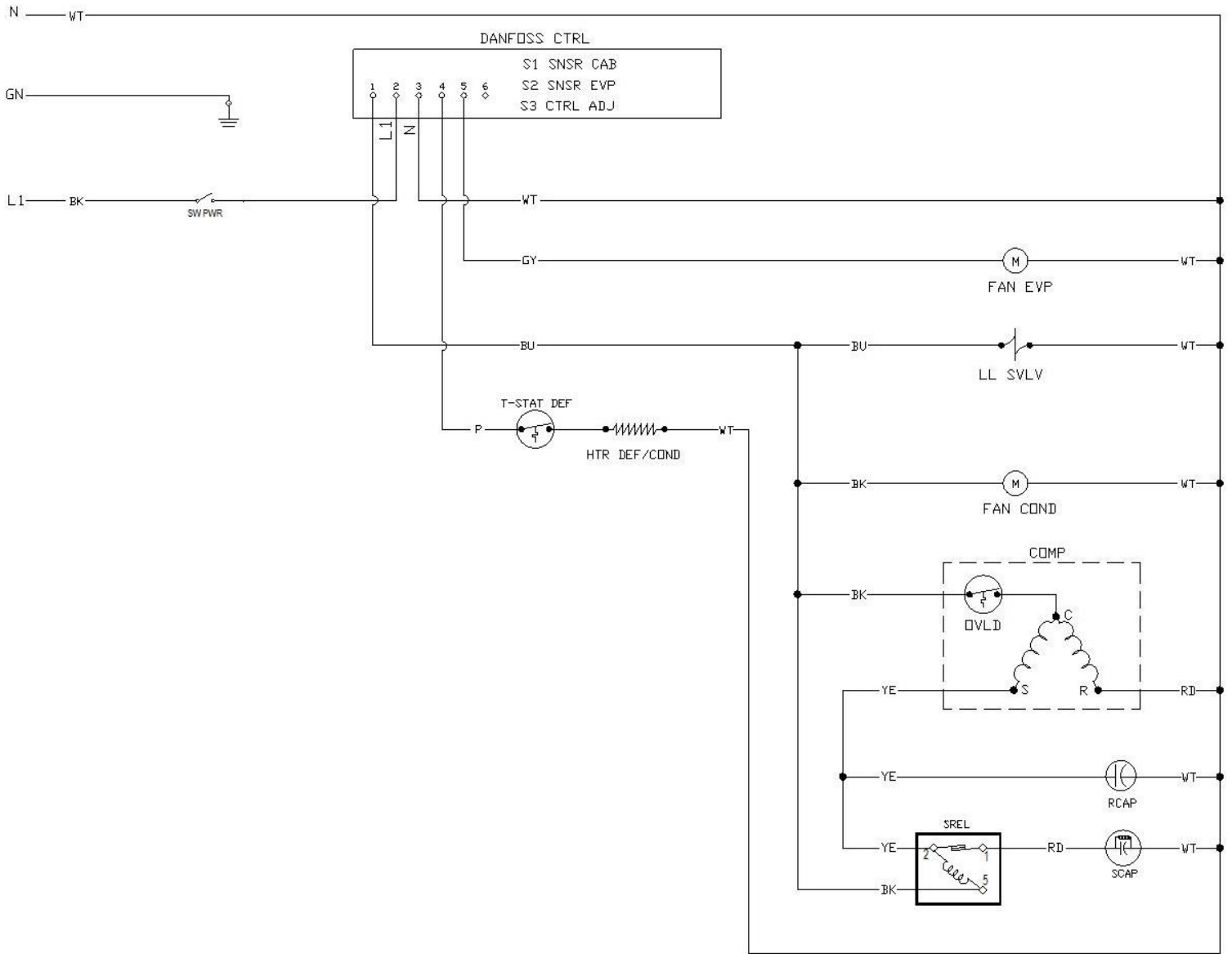

## VII. d - Milk Cooler Danfoss Series

