



**Quality Refrigeration**

# **OWNER'S MANUAL**

**Instructions for the installation, operation  
and maintenance of all Traulsen:**

**Reach-In & Roll-In Even Thaw Refrigerator Models**

*\*Traulsen's even thaw's are solely intended for thawing, and not for use as holding cabinets.*

**Reach-In: RET132EUT, RET232EUT & RET232NUT**

**Roll-In: RET232LUT**

This Traulsen unit is built to our highest quality standards. We build our refrigerators, freezers and heated cabinets this way as a matter of pride. This philosophy has made Traulsen the leader in commercial refrigeration since 1938. We thank you for your choice and confidence in Traulsen equipment and we know you will receive many years of utility from this equipment.

All Traulsen units are placed on a permanent record file with the service department. In the event of any future questions you may have, please refer to the model and serial number found on the name tag affixed to the unit. Should you need service, however, call us on our toll free number, 800-825-8220 between 7:30 am and 4:30 pm CST, Monday thru Friday. It is our pleasure to help and assist you in every possible way.

**INSTALLER**

**COMPLETE THE FOLLOWING INFORMATION PRIOR TO UNIT INSTALLATION**

INITIAL START DATE: \_\_\_\_\_ SERIAL NO. \_\_\_\_\_

MODEL TYPE: \_\_\_\_\_

COMPANY/INDIVIDUAL NAME: \_\_\_\_\_



INSTALLER: \_\_\_\_\_

# TABLE OF CONTENTS

<b>I. THE SERIAL TAG</b>	Page 1	<b>VI. OTHER</b>	
<b>II. RECEIPT INSPECTION</b>	Page 2	a-Service Information	Page 5
<b>III. INSTALLATION</b>		b-Spare Parts	Page 5
a-Location	Page 2	c-Warranty Registration	Page 5
b-Packaging	Page 2	<b>VII. GEN'L USE, OPERATION &amp; SERVICE</b>	Page 6
c-Installing Legs or Casters	Page 2	<b>VIII. EXPECTED THAW PERFORMANCE/ OPERATIONAL TROUBLESHOOTING</b>	
d-Tray Slides	Page 3	a-Introduction	Page 6
e-Cord & Plug	Page 3	b-Test Parameters	Page 6
f-Power Supply	Page 3	c-Test Results	Page 6
g-Wiring Diagram	Page 3	d-Results as a Function of Product Mix	Page 6
h-Clearance	Page 3	e-Incomplete Thawing	Page 7
i-Roll-In Model Installation	Page 3	f-Equipment Issues	Page 7
<b>IV. OPERATION</b>		g-Causes Of Extended Thaw Times	Page 7
a-Even-Thaw Overview	Page 3	<b>IX. TROUBLE SHOOTING GUIDE</b>	Page 8
b-Expected Performance	Page 3	<b>X. SPARE PARTS LIST</b>	Page 9
c-Even-Thaw Operation	Page 3	<b>XI. WIRING DIAGRAMS</b>	Page 10-12
d-Batch Loading	Page 4	<b>XII. WARRANTY INFORMATION</b>	Page 13
e-Process Loading	Page 4		
f-Interior Arrangements	Page 4		
g-Adjusting The Temperature Scale	Page 4		
h-Operator Controls, Blower Switch	Page 4		
i-Call Service Light	Page 4		
<b>V. CARE &amp; MAINTENANCE</b>			
a-Cleaning The Condenser	Page 4		
b-Hinge Replacement	Page 4		
c-Replacing The Gaskets	Page 5		
d-Cleaning The Exterior	Page 5		
e-Cleaning The Interior	Page 5		

## I. THE SERIAL TAG

The serial tag is a permanently affixed sticker on which is recorded vital electrical and refrigeration data about your Traulsen product, as well as the model and serial number. This tag is located in the upper right interior compartment on all reach-in/pass-thru and roll-in/roll-thru refrigerator, freezer and dual-temp models. For hot food models, this tag is located on the top of the unit behind the louvers to protect it from the heat.

		4401 Blue Mound Rd. Ft. Worth, TX 76106 800-825-8220	
			
MODEL:		SCAN FOR SERVICE INFO	
MODELO:			
MODELE:			
S/N:			
<b>REFRIGERANT / REFRIGÉRANTE / RÉFRIGÉRANT</b>			
SYS1 (REFM):			
Hi Press. (PRESH):			
Lo Press. (PRESL):			
SYS2 (REFA):			
Hi Press. (PRESH):			
Lo Press. (PRESL):			
<b>Input Power (EJIN) - FOR INDOOR USE ONLY</b>			
(Symbol 1) (Primary Safety)	(Symbol 2) (Primary Sanitation)	(Symbol 3) (Primary Energy)	(Symbol 4) (V/E/E)
(Symbol 5) (Alt Safety / Other)	(Symbol 6) (Alt Sanitation / Other)	(Symbol 7) (Alt Energy / Other)	(Symbol 8) (Cust QR Code / Other)
Device/Part Number: Part.Part#Num		Device/Part Notes: Part.Character04	
<b>COMPONENTS / COMPOSANTES / COMPONENTES</b>			
COMP AMPS:		LIGHT WAITS:	
COND FAN AMPS:		CTRL AMPS:	
SYS/DEF HTR AMPS:		R/TMCE HTR AMPS:	
DOOR HTR AMPS:		MIN CIRCUIT IN AMPS:	
SYS/EVAP FAN AMPS:		MAX OVR CURRENT PROTECTION AMPS:	
370-60297-00 REV.B 11/21/14			

## II. RECEIPT INSPECTION

All Traulsen products are factory tested for performance and are free from defects when shipped. The utmost care has been taken in crating this product to protect against damage in transit. All interior fittings have been carefully secured and the legs or casters are boxed and strapped inside to prevent damage. Door keys will be attached to the handle with a nylon strip. The handle is protected by an easily removable nylon netting.

You should carefully inspect your Traulsen unit for damage during delivery. If damage is detected, you should save all the crating materials and make note on the carrier's Bill Of Lading describing this. A freight claim should be filed within 10 days. If damage is subsequently noted during or immediately after installation, contact the respective carrier and file a freight claim. Under no condition may a damaged unit be returned to Traulsen without first obtaining written permission (return authorization).

## III. INSTALLATION

### III. a - LOCATION:

Select a proper location for your Traulsen unit, away from extreme heat or cold. Allow enough clearance between the unit and the side wall in order to make use of the door stay open feature at 120° (self-closing feature operates up to 90°). The door(s) must be able to open a minimum of 90° in order to make use of the maximum clear door width available.

### III. b - PACKAGING:

All Traulsen units are shipped from the factory bolted to a sturdy wooden pallet and packaged in a durable cardboard container. The carton is attached to the wooden skid with the use of large staples. These should first be removed to avoid scratching the unit when lifting off the crate.

Most exterior stainless steel surfaces have a protective vinyl covering to prevent scratching during manufacturing, shipping and installation. After the unit is installed in place of service, remove and discard the covering from all surfaces.

To remove the wooden pallet, first if at all possible, we suggest that the cabinet remain bolted to the pallet during all transportation to the point of final installation. The bolts can then be removed with a 3/4" socket wrench. Avoid laying the unit on its front, side or back for removal of the pallet.

**NOTE: DO NOT LAY THE UNIT ON ITS SIDE DURING TRANSPORTATION OR INSTALLATION.**

## III. INSTALLATION (continued)

### III. c - INSTALLING LEGS OR CASTERS:

6" high stainless steel legs are supplied standard for all Traulsen reach-in and pass-thru units. Casters in lieu of legs are available as an optional accessory for the same models. These are shipped from the factory packed inside a cardboard box which is strapped to one of the shelves. Remove the nylon strap and open the box, it should contain either four (4) legs or four (4) casters and sixteen (16) bolts.

**WARNING: THE CABINET MUST BE BLOCKED AND STABLE BEFORE INSTALLING LEGS OR CASTERS.**

To install the legs or casters, first raise and block the reach-in a minimum of 7" from the floor. For installing legs, thread the legs into the threaded holes on the bottom of the cabinet (see figure below). Be certain that all legs are tightly secured (legs and casters should be tightened to 300 inch/pounds, max). When the unit is set in its final position, it is important for proper operation that the unit be level. The legs are adjustable for this purpose, turn the bottom of the leg counter-clockwise to raise it, clockwise to lower it. Level the unit from front to back as well as side to side in this manner, using a level placed in the bottom of the cabinet.

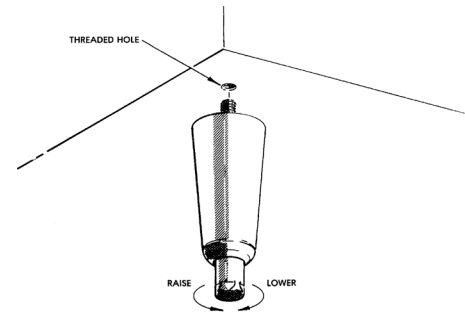

Please note that Traulsen units are not designed to be moved while on legs. If the unit requires moving, a pallet jack or forklift should be used to prevent damage. For installing casters, the casters are "plate" type, and require the use of four (4) bolts each to secure them firmly to the cabinet bottom at each corner (see figure below). The caster bolts are tightened using a 1/2" socket wrench.

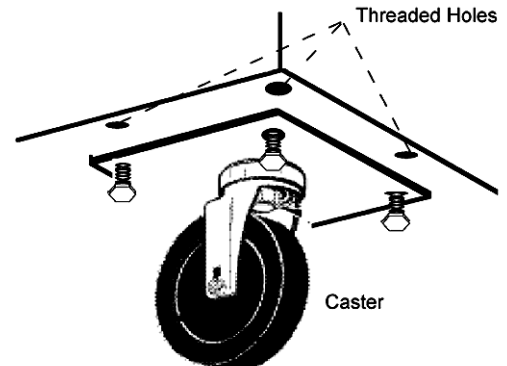

### III. INSTALLATION (continued)

#### III. d - TRAY SLIDES:

Reach-In models are supplied with fourteen (14) pairs of #1 type tray slides on 4" centers. These are shipped installed from the factory, and are easily removable for cleaning without tools.

#### III. e - CORD & PLUG:

Most self-contained models are supplied with a cord & plug attached. It is shipped coiled at the top of the cabinet, secured by a nylon strip. For your safety and protection, all units supplied with a cord and plug include a special three-prong grounding plug on the service cord. Select only a dedicated electrical outlet with grounding plug for power source.

**NOTE: Do not under any circumstances, cut or remove the round grounding prong from the plug, or use an extension cord.**

#### III. f - POWER SUPPLY:

The supply voltage should be checked prior to connection to be certain that proper voltage for the cabinet wiring is available (refer to the serial tag to determine correct unit voltage). Make connections in accordance with local electrical codes. Use qualified electricians. Use of a separate, dedicated circuit is required. Size wiring to handle indicated load and provide necessary overcurrent protector in circuit (see amperage requirements on the unit's serial tag).

#### III. g - WIRING DIAGRAM:

Refer to the wiring diagram for any service work performed on the unit. Should you require one, please contact Traulsen Service at (800) 825-8220, and provide the model and serial number of the unit involved.

#### III. h - CLEARANCE:

In order to assure optimum performance, the condensing unit of your Traulsen unit **MUST** have an adequate supply of air for cooling purposes. Therefore, the operating location must either have a minimum of 12" clearance overhead of the condensing unit or allow for unrestricted air flow at the back of the unit. Clearance of at least 12" above is required in order to perform certain maintenance tasks.

#### III. i - ROLL-IN MODEL INSTALLATION:

Roll-In cabinets set on the floor require the floor area to be flat and level. In addition, after the cabinet is set in place, sealant should be used around the perimeter of the base to comply with National Sanitation Foundation requirements (see figure 4). After sealing the unit, the enclosed ramp should then be installed.

A stainless steel threshold ramp(s) is included to facilitate rolling in racks. It is shipped wrapped in brown paper and secured to the rack guides inside the cabinet. To secure it in place, remove the two thumb screws in the breaker strip near the bottom door opening. Next, loosen the thumb screws located along the floor at the threshold.

### IV. OPERATION

#### III. i - ROLL-IN MODEL INSTALLATION:

Place the ramp(s) on top of the loosened thumb screws and secure tabs on each end to breaker strips with thumb screws previously removed. After installing the ramp(s), it too should be sealed to the floor.

Bumper strips are secured to the back of Roll-In models with thumb screws. Loosen these and make them finger tight to conform with the requirements of the National Sanitation Foundation (NSF).

#### IV. a - EVEN-THAW OVERVIEW:

The "Even-Thaw" refrigerator was specially designed to thaw frozen food product under safe, temperature controlled conditions. It is not intended as a storage refrigerator.

**NOTE: USING THIS REFRIGERATOR FOR STORAGE OF UNCOVERED PRODUCT IS NOT RECOMMENDED.**

#### IV. b - EXPECTED PERFORMANCE:

The Traulsen Even-Thaw refrigerator is designed to thaw a full load of frozen food product (see BATCH LOADING for guidelines) in approximately 18 to 24 hours. However, be aware that actual thawing times will vary depending upon a number of variables, such as product type, product packaging, density, spacing, etc. Please note that some other loading variables, such as product location, are not important to thawing and do not effect thaw cycle duration.

#### IV. c - EVEN THAW OPERATION:

The Traulsen Even-Thaw cabinet is a refrigerator, with two important additional features: 1) the ability to introduce small amounts of heat into the cabinet, and 2) increased air flow, indicated by the presence of blowers mounted behind the mullion.

The Even-Thaw refrigerator operates continually, the introduction of frozen product lowers the cabinet temperature below the heater setpoint temperature (37°F). This prompts the refrigeration system to turn OFF, and the heaters to turn ON. Anytime the cabinet air temperature is below the heater setpoint temperature, additional heat is added. Heater operation is controlled proportionally, i.e. the colder the cabinet temperature, the longer the heaters remain in operation. When the cabinet air temperature reaches above the heater setpoint temperature, the heaters turn OFF.

When the cabinet air temperature reaches the upper refrigerator setpoint temperature (40°F), the refrigeration cycle is initiated. As long as product does not lower the cabinet temperature below the lower refrigeration setpoint temperature (37°F), the cabinet will continue to cycle between 38°F and 40°F. Upon completion of a thaw cycle, the thawed product should then be removed from the Even-Thaw cabinet and placed in a dedicated storage refrigerator.

## IV. OPERATION (continued)

### IV. d - **BATCH LOADING:**

The Even-Thaw model can accommodate any size partial load, or up to twenty eight (28) 18" x 26" pans of product. Use of aluminum pans is highly recommended. Product should be placed on pans in one layer only to allow for proper air flow.

When completely loaded with frozen product (at approximately -5°F), the interior cabinet air temperature will begin to drop and approach the product temperature as a result. When this occurs the heaters begin operation in order to return the cabinet temperature back up to the heater setpoint temperature (37°F). This portion of the thaw cycle may take place for approximately 8 to 12 hours. With a full product load the interior cabinet temperature should remain at or below 37°F for approximately 8 to 12 hours of the expected 18-24 hour total thaw cycle time.

### IV. e - **PROCESS LOADING:**

If the cabinet is unloaded as needed and replaced with frozen product, the average cabinet temperatures remain higher. A fully loaded cabinet with the refrigeration system cycling from 38°F to 40°F thaws product faster than one maintaining operation at below 32°F air temperatures for several hours.

### IV. f - **INTERIOR ARRANGEMENTS:**

Each reach-in Even-Thaw model includes 14 pairs of #1 trayslides (16 gauge stainless steel angle type) for bottom support of either: (1) 18" x 26" pan per pair of tray slides or (2) 14" x 18" pans per pair of tray slides, per section.

### IV. g - **ADJUSTING THE TEMPERATURE SCALE:**

The Traulsen Even-Thaw model is preset at the factory to operate within strict temperature parameters. Please contact our Service Department at (800) 825-8220 for any additional technical support.

## V. CARE & MAINTENANCE

### V. a - **CLEANING THE CONDENSER:**

The most important thing you can do to insure a long, reliable service life for your Traulsen is to regularly clean the condenser coil.

The condensing unit requires regularly scheduled cleaning to keep the finned condenser clean of lint and dust accumulation. Keeping the condenser clean allows the cabinet to operate more efficiently and use less energy.

To clean the condenser, first disconnect electrical power to the cabinet and lift up the front louver assembly. To lift this, remove the two screws located on both sides at the bottom of the louver assembly. Once the screws are removed, the panel can be pivoted upwards allowing full access to the front facing condenser. Vacuum or brush any dirt, lint or dust from the finned condenser coil, the compressor and other cooling system parts. If significant dirt is clogging the condenser fins, use compressed air to blow this clear.

Lower louver assembly and replace the screws to hold it in place.

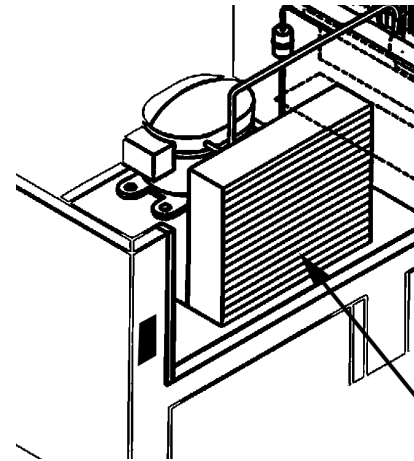

### V. b - **HINGE REPLACEMENT:**

Both the door and hinge can be easily removed from the cabinet. To remove the door, remove the plug at the bottom of the top hinge. Inside the hinge there is a small screw which secures the door in place. Remove this with a flat head screwdriver and the door can then be lifted off the hinge. To remove the door portion of the hinge from the door, lift off the hinge cover and then remove the three Phillips head screws which secure the hinge in place on the door. To remove the cabinet portion of the hinge, remove the three Phillips head screws which hold it in place. On solid door units, the top hinge(s) contains a microswitch for controlling the interior lighting.

To reassemble the hinge reverse the previous procedure.

## V. CARE & MAINTENANCE (continued)

### V. c - REPLACING THE GASKETS:

To remove the gasket to be replaced, grasp it firmly by one corner and pull it out. Before attempting to install a new gasket, both the unit and the gasket itself must be at room temperature. Insert the four corners first by using a rubber mallet (or hammer with a block of wood). After the corners are properly inserted, work your way towards the center from both ends by gently hitting with a mallet until the gasket is completely seated in place (see figure below for proper gasket placement).

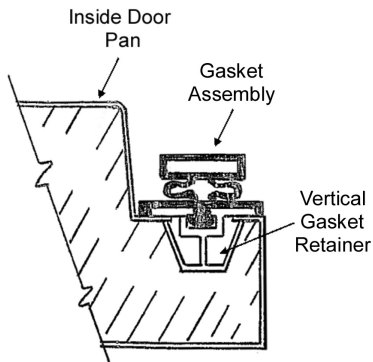

**NOTE:** The gasket may appear too large, but if it is installed as indicated above it will slip into place.

### V. d - CLEANING THE EXTERIOR:

Exterior stainless steel should be cleaned with warm water, mild soap and a soft cloth. Apply with a dampened cloth and wipe in the direction of the metal grain.

Avoid the use of strong detergents and gritty, abrasive cleaners as they may tend to mar and scratch the surface. Do NOT use cleansers containing chlorine, this may promote corrosion of the stainless steel.

Care should also be taken to avoid splashing the unit with water, containing chlorinated cleansers, when mopping the floor around the unit.

For stubborn odor spills, use baking soda and water (mixed to a 1 TBSP baking soda to 1 pint water ratio).

### V. e - CLEANING THE INTERIOR:

For cleaning both stainless steel and anodized aluminum interiors, the use of baking soda as described in section "V. d" is recommended. Use on breaker strips as well as door gaskets. All interior fittings are removable without tools to facilitate cleaning.

## VI. OTHER

### VI. a - SERVICE INFORMATION:

Before calling for service, please check the following:

- Is the electrical cord plugged in?
- Is the fuse OK or circuit breaker on?
- Is the power switch "ON"?

If after checking the above items and the unit is still not operating properly, please contact an authorized Traulsen service agent. A complete list of authorized service agents was provided along with your Traulsen unit. If you cannot locate this, you may also obtain the name of a service agent from the **SERVICE & PARTS** button of our website: [www.traulsen.com](http://www.traulsen.com).

If service is not satisfactory, please contact our in-house service department at:

**Traulsen**  
**4401 Blue Mound Road**  
**Fort Worth, TX 76106**  
**(800) 825-8220**

Traulsen reserves the right to change specifications or discontinue models without notice.

### VI. b - SPARE PARTS:

Spare or replacement parts may be obtained through a parts supplier or one of our authorized service agents. A complete list of authorized service agents is posted on the on our company's official website @ [www.traulsen.com](http://www.traulsen.com) under the **SERVICE & PARTS** button.

### VI. c - WARRANTY REGISTRATION:

For your convenience, the warranties on your new Traulsen unit may be registered with us on-line at [www.traulsen.com](http://www.traulsen.com), under the **SERVICE & PARTS** button.

## VII. GENERAL USE, OPERATION & SERVICE SUMMARY

### VII. a - INTRODUCTION/OVERVIEW:

The Traulsen Even Thaw is designed to be used as a thawing cabinet. While it may be utilized in a refrigeration mode, that is not its intended use. Its function is to hold the cabinet temperature in the range from 38 to 40 degrees to thaw product within the food-safe temperature zone.

Frozen product placed into the unit will pull the cabinet temperature below the heater set point (37 deg.) and the unit will begin to function in the thaw mode. This prompts the refrigeration system to turn OFF, and the heaters to turn ON. The fans remain ON, circulating this cold air around the product, allowing for rapid thawing. When cabinet air temperature reaches the upper set point (38 deg. although the product is actually much colder), the heaters turn OFF.

As the cabinet temperature reaches the heater set point, the heat will be cycled off while the internally generated heat from the circulation fans continues to add heat to the cabinet. If sufficient cold capacity or possibly other frozen product is added to the unit and subsequently lowers the cabinet temperature more than 1 degree below the heater set point, the heat will again turn on to thaw the product.

If the cold capacity of the product no longer sufficiently pulls down the cabinet temperature below the heater set point, the cabinet temperature will slowly rise to attain the evaporator coil cut-in set point (41 deg.) and energize the refrigeration system. The unit will remain in the refrigeration mode until the cabinet temperature pulls down to the compressor cut-out set point (38 deg.). The unit will continue to operate and cycle in the refrigeration mode.

The controller has been preset at the factory and should not require any adjustments. Traulsen engineering EXPECTS no changes be made to any set-points or parameter settings without discussing the situation and obtaining approval to do so. Modifying the default set points could disrupt the operation/functional programming algorithm and result in erratic unit operation.

### VII. b - LOADING GUIDELINES:

The Even-Thaw model can accommodate any size partial load, or up to (28) 18" x 26" pans of product (for example approximately 672 lbs. of chicken). Use of aluminum pans is highly recommended. Product should be placed on pans in one layer only to allow for proper airflow. With a full load thaw time will be between 22 & 24 hours. Overloading and/or double wrapping product will extend thaw times.

## VIII. EXPECTED THAW PERFORMANCE/OPERATIONAL TROUBLESHOOTING

### VIII. a - INTRODUCTION:

Even thaw performance is a function of many factors, especially those involving product types and loading. As a result, actual thaw times will vary as even similar sized loads of the same product will exhibit some differences in their thawing characteristics.

### VIII. b - TEST PARAMETERS:

To provide a general performance baseline, Traulsen performed some controlled testing in our lab which may provide the operator with an approximate idea on what to expect from their Even-Thaw unit. Full load batches of frozen product were used as follows:

#### **One section models**

336 lbs. of chicken, distributed between 14 tray levels. Each level consisted of 24 lbs. of product loaded into two pans (four 6 lb. pkgs. of frozen product total per level/two 6 lb. pkgs. per tray).

#### **Two section models**

672 lbs. of chicken, distributed between 28 tray levels. Each level consisted of 24 lbs. of product loaded into two pans (four 6 lb. pkgs. of frozen product total per level/two 6 lb. pkgs. per tray).

1008 lbs. of chicken, for two section megathaw loads.

### VIII. c - TEST RESULTS:

Under these actual load parameters, the one-section model generally required approximately 15-19 hours in order to completely thaw the entire load.

The two section model requires approximately 18-22 or megathaw models 22-24 hours to completely thaw the entire load.

### VIII. d - RESULTS AS A FUNCTION OF PRODUCT MIX:

The above thaw times were based upon a mixed load of different chicken products typically found in many establishments. It is important to note that initially, all tests performed were based on a mixed load of product. This consisted of approximately 1/4 nuggets, 1/4 strips, 1/4 to 1/3 breasts. This MIXED batch thawed in the times listed above. In actual operation, thaw batches consisting of a single type of product, or other ratios of different products may require more time for thawing. Both this and larger size loads can both contribute to longer thaw times.

## VIII. EXPECTED THAW PERFORMANCE/OPERATIONAL TROUBLESHOOTING

(continued)

### VIII. e - INCOMPLETE THAWING:

In operation, incomplete thawing (i.e. bags of product in which not every piece was completely thawed) has been found to usually be the result of those pkgs. respective pan level having had restricted airflow due to overloading (from stacked pkgs. or irregular shaped packages that blocks air from getting to the pkgs. closest to the cabinet interior side wall or rear). Allowing for proper air-flow around each pkgs. of frozen product should eliminate this situation from occurring.

### VIII. f - EQUIPMENT ISSUES:

If improper loading has been eliminated as a possible cause for extended thaw cycle times, there are several system checks which can be done to diagnose the Traulsen Even-Thaw unit.

First, the amp draw should be checked early in the thaw cycle. This is a 1300 watt heater, 115 vac, is about 11.3 amps. Add 4 blowers at 1.1 amps and a few amps for the controls and the total amp draw should be approximately 16 to 16.5 amps.

If your amp reading is different, call Traulsen technical support to help diagnose the problem.

### VIII. g - OTHER CAUSES OF EXTENDED THAW TIMES:

Some frozen products are often stored in large, irregularly shaped packages. If used, these should always be located along the outside wall with the largest packages being placed closest to, but not directly against, the wall. It is IMPERATIVE that such large packages not be placed up against the center mullion air ducts. This could result in blocked airflow.

### REDUCED AIR MOVEMENT EQUATES TO LONGER THAWING TIMES.

Care should also be taken to avoid pushing other pkgs. of frozen product up against the mullion sheet metal ducts. Airflow could be blocked resulting in a similar extended thaw time situation. Another scenario to avoid is for packages to be placed inadvertently up against the outside walls. They will also block air flow down the sides of the unit. This is especially an issue with the right side wall because when the unit returns to normal refrigerated operation mode, the cold air flows from the upper right ceiling evaporator outlet, down the wall, and then mixes into the cabinet, distributed by all the mullion blowers. If the right wall is blocked, and especially if blocked near the top right of the cabinet, the cold evaporator exit air can be short circuited on to the top two or three upper right hand levels and be routed right back to the return evaporator inlet duct. Therefore, those upper shelves could get very cold and perhaps a substantial amount of product on the right side could become very cold and possibly even refreeze (as the evaporator outlet air temperature is 20 degrees F).

## IX. TROUBLE SHOOTING GUIDE

FIND YOUR PROBLEM HERE	REMEDY
1. Condensing unit fails to start.	a. Check if cord & plug has been disconnected.
2. Condensing unit operates for prolonged periods or continuously.	a. Are doors closing properly? b. Dirty condenser or filter. Clean properly. c. Evaporator coil iced. Needs to defrost. d. Shortage of refrigerant, call service.
3. Food compartment is too warm.	a. Check door(s) and gasket(s) for proper seal
4. Condensation on the exterior surface.	a. Check door alignment and gaskets for proper seal.
5. Compressor hums but does not start.	a. Call for service.
6. Excessively long product thaw times.	a. Call for Service.

## X. SPARE PARTS LIST

MODEL	DESCRIPTION	PART NUMBER
<b>RE132E-FHS</b>	FULL HEIGHT DOOR GASKET	341-60105-00
	TXV VALVE 404A	325-60080-08
	LIGHT BULB	378-29776-00
	MIT II CONTROL MODULE 110V	337-60317-60
	OFF/ON POWER SWITCH	337-60346-00
	AIR FILTER	341-60062-05
	CONDENSER FAN BLADE	325-60135-00
	CONDENSER FAN MOTOR	338-60050-00
	TRAY SLIDE, #1 LONG	701-60032-00
	<b>RE232E-FHS</b>	FULL HEIGHT DOOR GASKET
TXV VALVE 404A		325-60080-39
LIGHT BULB		378-40414-00
MIT II RELAY MODULE 230V		337-60317-61
OFF/ON POWER SWITCH		337-60346-01
AIR FILTER (MEGA THAW)		341-60062-06
CONDENSER FAN BLADE		325-60088-00
CONDENSER FAN MOTOR		338-60049-01
TRAY SLIDE, HIGH CAPACITY		701-60933-00
<b>RE232N-FHS</b>		HALF HEIGHT DOOR GASKET
	FULL HEIGHT DOOR GASKET	341-60059-00
	TXV VALVE 404A	325-60080-39
	LIGHT BULB	378-29776-00
	MIT II RELAY MODULE 110V	337-60317-60
	OFF/ON POWER SWITCH	337-60346-00
	AIR FILTER	341-60062-05
	CONDENSER FAN BLADE	325-60088-00
	CONDENSER FAN MOTOR	338-60049-00
	TRAY SLIDE, #1 LONG	701-60032-00
<b>ALL MODELS</b>	FILTER DRIER	325-60103-00
	MIT II CONTROL HEAD	337-60318-00
	HYBRID RELAY	337-60360-01
	HEATER RELAY	337-60311-02
	CABINET SENSOR (GREEN)	337-60405-02
	COIL SENSOR (BLUE)	337-60406-02
	LIQUID LINE SENSOR (YELLOW)	337-60407-01
	THERMAL FUSE	337-31075-02
	LOCK KEY T42	358-28924-42
	LOCK CYLINDER	346-13186-42
	LOCK BOLT	346-13189-00
	6" PLATE MOUNT CASTER	344-13140-01
	6" SS ADJUSTABLE LEG	344-13168-01
	DOOR HINGE ASSEMBLY	SER-28583-00
	MULLION BLOWER ASSEMBLY115V	SER-60545-00
	MULLION BLOWER ASSEMBLY230V	SER-60545-01
	EVAPORATOR BLOWER ASSEMBLY 230V	SER-60545-03
EVAPORATOR BLOWER ASSEMBLY 115V	SER-60545-02	
<b>RET232LUT-FHS</b>	FULL HEIGHT DOOR GASKET	341-16473-00
	TXV VALVE 404A	325-60080-39
	LIGHT BULB	358-29776-00
	MIT II CONTROL MODULE 110V	337-60317-61
	OFF/ON POWER SWITCH	337-60346-01
	CONDENSER FAN BLADE	325-60088-00
CONDENSER FAN MOTOR	338-60049-01	

# XI. WIRING DIAGRAM ALL ONE SECTION MODELS ONLY

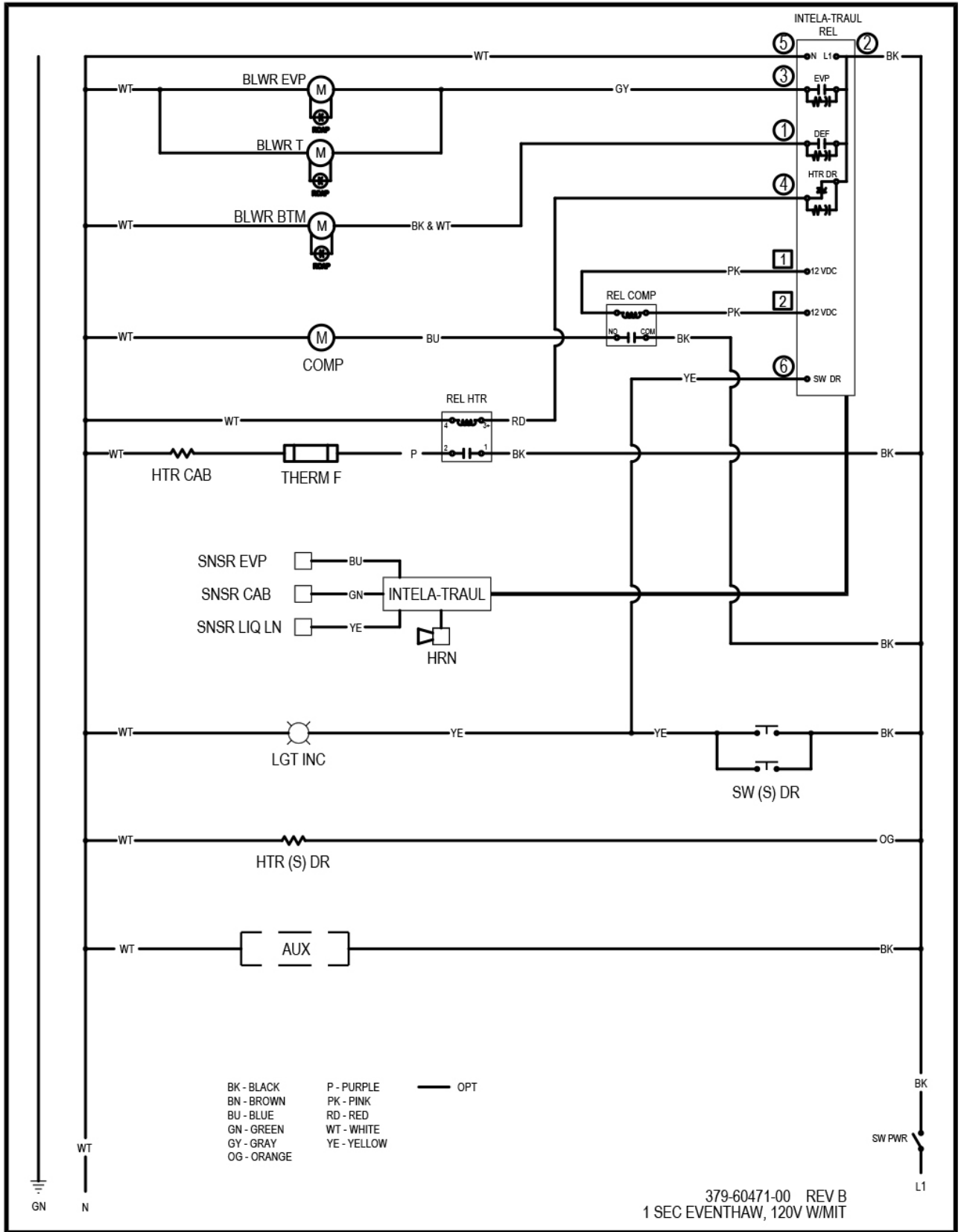

# XI. WIRING DIAGRAM ALL TWO SECTION 120V MODELS ONLY

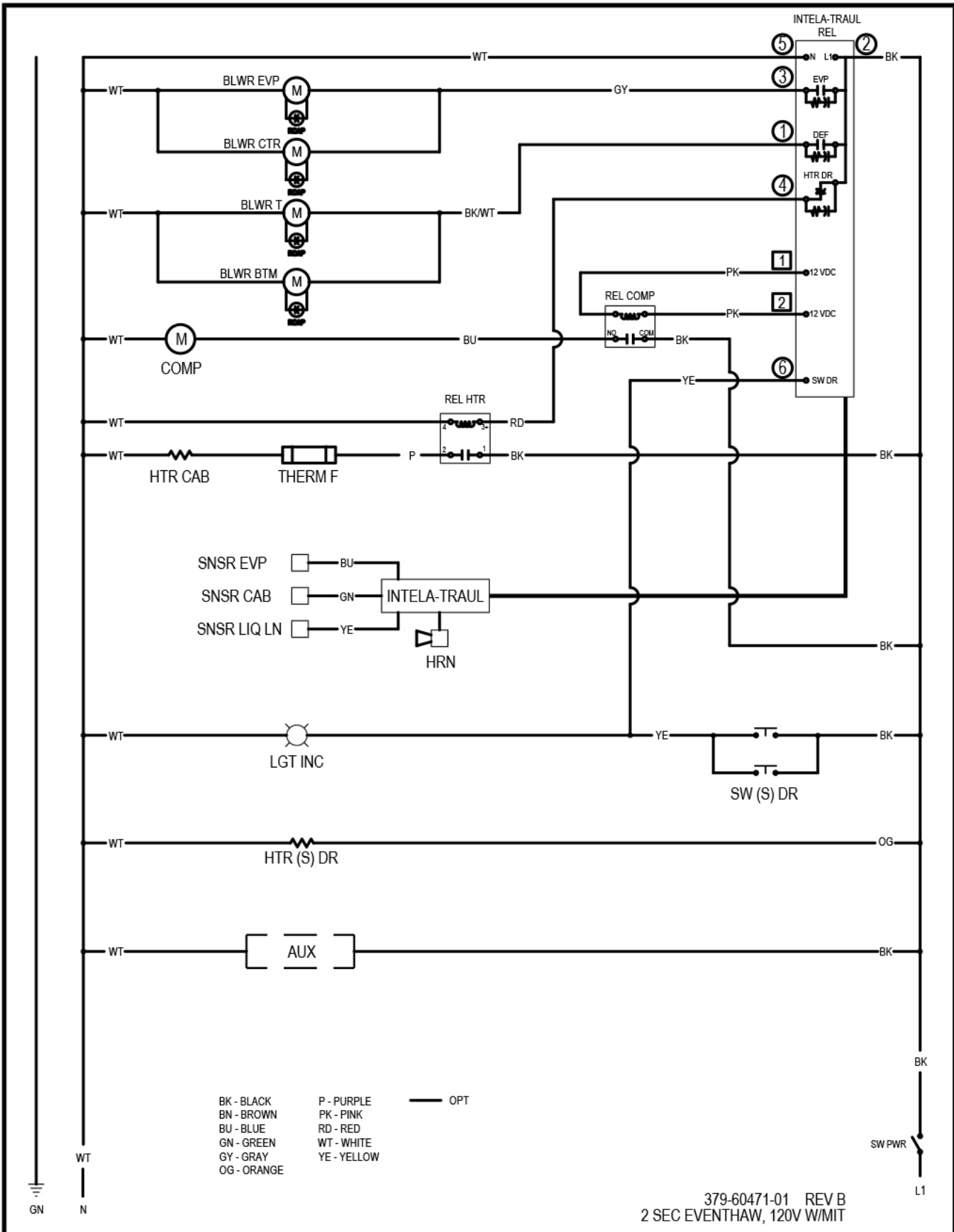

# XI. WIRING DIAGRAM ALL TWO SECTION 208V MODELS ONLY

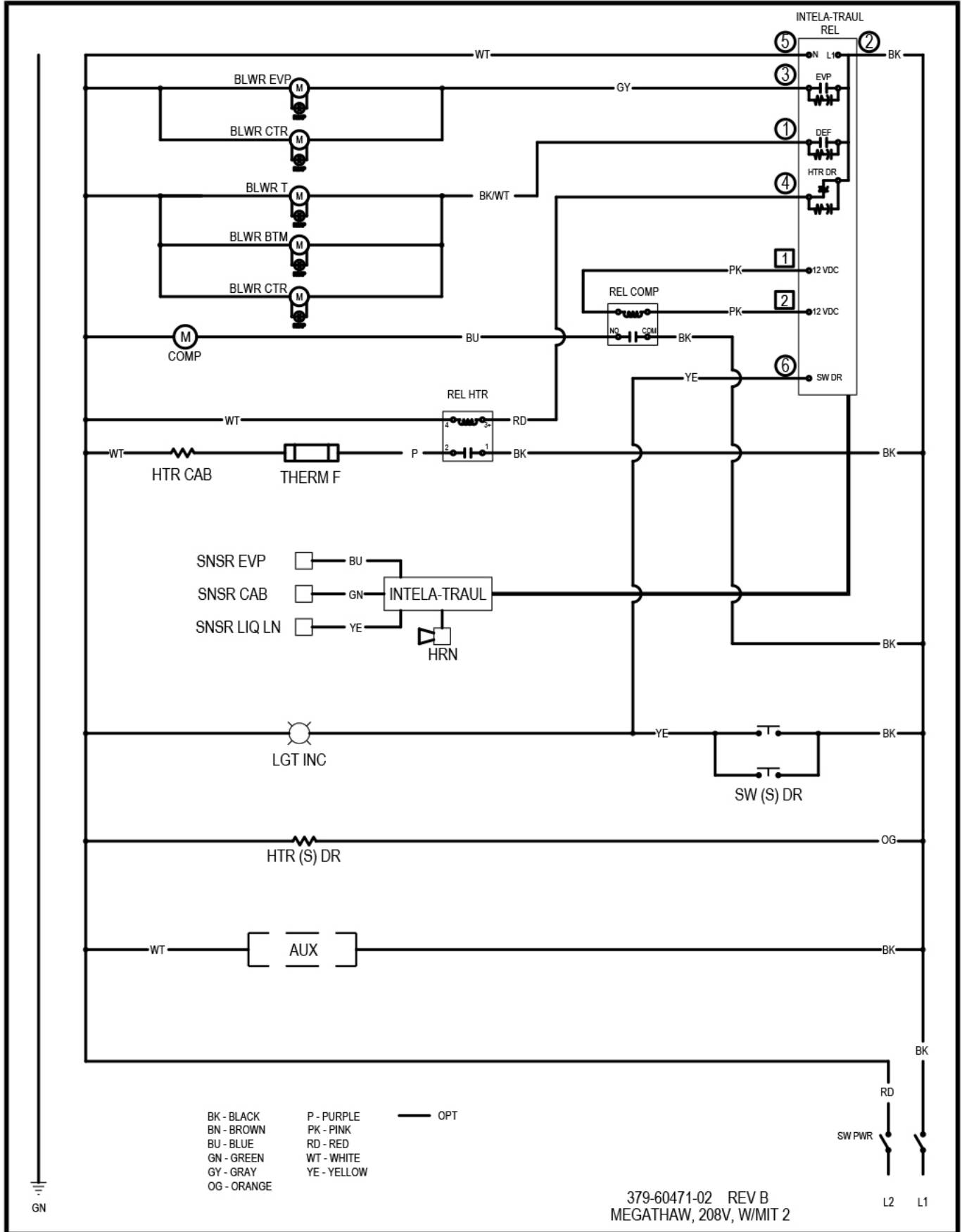

## XII. WARRANTY INFORMATION



### STANDARD DOMESTIC WARRANTY

(this warranty applies to units manufactured after January 01, 2013)

TRAULSEN warrants new equipment to the original purchaser, when installed within the United States against defective material and workmanship for three (3) years from the date of original installation. Under this warranty, TRAULSEN will repair or replace, at its option, including service and labor, all parts found to be defective and subject to this warranty. Warranty term begins upon the date of Installation, the date of End User Invoice or the date of Dealer Invoice, whichever is proven to occur latest, not to exceed 18 months from Dealer Invoice date (the "Warranty Period"). Warranty excludes components that are removable without tools.

The compressor part is warranted for an additional two (2) years. During this period TRAULSEN will supply replacement compressor(s) if deemed defective, however all installation, recharging and repair costs will remain the responsibility of the owner.

This warranty does not apply to damage resulting from fire, water, burglary, accident, abuse, misuse, transit, acts of God, terrorism, attempted repairs, improper installation by unauthorized persons, and does not apply to food loss.

For Traulsen units purchased with a remote feature, standard warranty will apply only to those components contained within the unit to the point of connection of the refrigeration lines leading to the remote condenser.

"Defective Part Return" – All claimed defective replacement part(s) must be returned to TRAULSEN for inspection within 30 days from the date of the repair. Failure to return all claimed defective part(s) to TRAULSEN will invalidate the warranty claim, this warranty statement, and forfeit payment for those repairs affected.

### INTERNATIONAL COMMERCIAL WARRANTY

TRAULSEN warrants to the original purchaser the Refrigeration Equipment shall be manufactured free from defects in material and workmanship under normal use and service for a period of one (1) year from date of shipment. Under this warranty, TRAULSEN will reimburse the purchaser for the replacement of any part of said equipment (excluding dryers & refrigerant gas) which then proves to be defective. This warranty does not apply to damage resulting from fire, water, burglary, accident, abuse, misuse, transit, acts of God, terrorism, attempted repairs, improper installation by unauthorized persons, and will not apply to food loss.

TRAULSEN'S standard warranty does not apply to Export Sales. Rather, for a period of one (1) year from date of original installation not to exceed Fifteen (15) months from date of shipment from factory, TRAULSEN: will, at Traulsen's sole discretion, replace or repair, F.O.B. factory, any defective parts normally subject to warranty and will not cover the cost of packing, freight or labor, such costs being the sole responsibility of the dealer.

**THERE ARE NO ORAL, STATUTORY OR IMPLIED WARRANTIES APPLICABLE TO TRAULSEN, INCLUDING BUT NOT LIMITED TO, ANY IMPLIED WARRANTY OF MERCHANTABILITY OR FITNESS FOR ANY PARTICULAR PURPOSE WHICH EXTEND BEYOND THE DESCRIPTION ON THE FACE HEREOF. TRAULSEN SHALL HAVE NO OBLIGATION OR LIABILITY FOR CONSEQUENTIAL OR SPECIAL DAMAGES, INCLUDING, BUT NOT LIMITED TO, INDIRECT, PUNITIVE DAMAGES, LOSS OF USE, LOSS OF PRODUCT, DOWN TIME OR LOST PROFITS, GROWING OUT OF OR WITH RESPECT TO THE EQUIPMENT OR ITS SALE, OPERATION OR USE, AND TRAULSEN NEITHER ASSUMES NOR AUTHORIZES ANYONE ELSE TO ASSUME FOR IT ANY OBLIGATION OR LIABILITY IN CONNECTION WITH THE EQUIPMENT OR ITS SALE, OPERATION OR USE OTHER THAN AS STATED HEREIN.**

**THIS WARRANTY IS IN LIEU OF ALL OTHER WARRANTIES EITHER EXPRESSED OR IMPLIED AND CONSTITUTES TRAULSEN'S FULL OBLIGATION AND LIABILITY. WARRANTIES NOT AVAILABLE ON REMOTE MODELS.**

**Notes:**

**HOURS OF OPERATION:**

Monday thru Friday 7:30 am - 4:30 pm CST



Quality Refrigeration

**Traulsen**

4401 Blue Mound Road Fort Worth, TX 76106  
Phone: (800) 825-8220 Fax-Svce: (817) 740-6757  
Website: [www.traulsen.com](http://www.traulsen.com)