



SERVICE MANUAL



Milk Cooler Refrigerator Service Manual

Models RMC36, RMC49, RMC58

**This manual is applicable for all models using:
R-290 (Propane) Refrigerants**

Please Note: This manual is intended for use with the above referenced equipment manufactured in or after 2023. To obtain a copy of the correct Service Manual to support the same products manufactured prior to this date, please contact Traulsen Service at **(800) 825-8220**.

4401 Blue Mound Road Fort Worth, Texas 76106 (USA)
Phone: 800.825.8220 | E-mail: service@traulsen.com | Website: traulsen.com
Form Number: TR00369 | Revision Date: 6-2024

Hours of Operation: Monday - Friday 7:30 a.m. - 4:30 p.m. (CST)

Table of Contents

1. Introduction	7
1.1 The Serial Tag	7
1.2 Serial Tag & Location	7
1.2.1 Reading the Serial Tag.....	7
1.3 Understanding Milk Cooler Model Numbers	7
1.4 Reading Traulsen Serial Numbers	8
1.5 Refrigerants.....	8
1.5.1 Terminology.....	8
1.5.2 R-290 (Propane) Refrigerant.....	9
1.5.3 Troubleshooting Guide	9
1.6 Shipping and Assembly	10
1.6.1 Location.....	10
1.6.2 Packaging	10
1.6.3 Installing Legs or Casters	10
1.6.4 Cord & Plug	11
1.6.5 Power Supply.....	11
1.6.6 Wiring Diagram	11
1.6.7 Cleaning the Exterior	11
1.6.8 Cleaning the Interior	11
1.6.9 Temperature Control.....	11
1.6.10 Top Door Latch.....	11
1.6.11 Troubleshooting Guide Chart.....	12
1.6.12 Troubleshooting Guide.....	12
1.6.13 Service Information	12
1.7 Specifications.....	13
2. Preventative Maintenance	15
2.1 Inspect & Clean Unit	15
2.2 Inspect & Clean Door Gasket(s)	15
2.3 Clean Condenser Coil.....	15
3. Doors & Hardware	18
3.1 Hinges	18
3.1.1 Removing the Doors & Hardware	18

Table of Contents

3.2 EZ-Clean Gaskets.....	20
3.3 Locks.....	21
3.3.1 Door Lock Assembly: Exploded View.....	21
3.3.2 Door Lock Replacement Instruction.....	22
4. Controls.....	23
4.1 Control Cover Removal & Components.....	23
4.1.1 Removing the Display.....	23
4.1.2 Installing the Display.....	23
4.2 Control Basics.....	24
4.3 Information Menu.....	24
4.4 Adjusting Cabinet Setpoint.....	24
4.5 Initiating a Defrost.....	24
4.6 Configuration Parameters.....	25
4.7 Technical Data.....	25
4.8 Defrost Mode.....	30
5. Sensor Location.....	31
5.1 Sensor Resistance Test.....	32
6A. UL/IEC/CE.....	33
6A.1 Electrical outputs for refrigerant detection system.....	33
6A.2 Refrigerant detection system self-test routine.....	33
6A.3 Serviceability.....	33
6A.4 REFRIGERANT SENSOR identification.....	33
6A.5 Qualification of workers.....	33
6A.6 Information on servicing.....	33
6A.6.1 Checks to the area.....	34
6A.6.2 Work procedure.....	35
6A.6.3 General work area.....	35
6A.6.4 Checking for presence of refrigerant.....	35
6A.6.5 Presence of fire extinguisher.....	35
6A.6.6 No ignition sources.....	35
6A.6.7 Ventilated area.....	35
6A.6.8 Checks to the refrigerating equipment.....	35

Table of Contents

6A.6.9 Checks to electrical devices	36
6A.7 Repairs to sealed components	36
6A.8 Repair to intrinsically safe components	36
6A.9 Cabling	36
6A.10 Detection of flammable refrigerants	36
6A.11 Removal and evacuation	37
6A.12 Charging procedures	37
6A.13 Decommissioning	38
6A.14 Labeling	38
6A.15 Recovery	38
6A.16 Warning notices	39
6B. Troubleshooting	41
6B.1 Additional Requirements & Precautions for R-290 (Propane) Systems	41
6B.2 Condensate Overflow Troubleshooting.....	43
6B.2.1 Condensate Overflow	43
6B.3 Leak Checking System	43
6B.4 Accessing the Refrigeration System.....	44
6B.5 Refrigerant Recovery.....	44
6B.6 Repair of Leaks.....	45
6B.7 System Evacuation.....	45
6B.8 Charging the System	45
6B.9 Remove Access Ports	45
6B.10 Compressor Troubleshooting	46
6B.10.1 Terminology	46
6B.10.2 Accessing the Compressor.....	46
6B.10.3 Compressor Not Running.....	47
6B.10.4 Testing the Windings of the Compressor	47
6B.10.5 Resistance & Amp Values of Milk Cooler Compressors.....	47
6B.10.6 Troubleshooting External Overload Protector	47
6B.10.7 Measuring for Excessive Voltage Drop.....	47
6B.10.8 Troubleshooting Potential Relay	47
6B.10.9 Troubleshooting Start Capacitor (Black Plastic Casing)	48

Table of Contents

6B.10.10 Troubleshooting Run Capacitor (Metal Casing).....	48
6B.10.11 Locked Up Compressor	49
6B.10.12 Current Climbs Above RLA.....	49
6B.10.13 Replacing the Compressor	49
6B.10.14 Milk Cooler Temperature Checklist	50
6B.10.15 Compressor Wiring Schematics.....	51
6B.10.16 Compressor Short Cycles on Overload Protection	52
6B.10.17 Compressor Non-Start.....	53
6B.11 CF10B Electric Inverter	54
6B.11.1 General Product Specifications	54
6B.11.2 Technical Specifications	55
6B.11.3 Connectors	56
6B.11.4 Connection	57
6B.11.5 LED Indication	57
6B.11.6 Troubleshooting	58
6B.11.7 Diagnostics.....	59
6B.12 Evaporator Fan Troubleshooting	60
6B.12.1 Steps for Troubleshooting Milk Cooler Evaporator Fan	60
6B.13 Condenser Fan Troubleshooting.....	63
6B.13.1 Troubleshooting the Condenser Fan Motor on Milk Cooler	63
6B.13.2 Motor Bearing Failure	63
6B.13.3 Access and Removal of Condenser Fan Motor	64
6B.14 Troubleshooting Thermostatic Expansion Valve.....	65
6B.14.1 Three Pressures.....	65
6B.14.2 Non-Bleed Type.....	65
6B.14.3 Maximum Operating Pressure	65
6B.14.4 Measuring Superheat.....	66
6B.14.5 Restrictions	66
6B.14.6 Replacing the TXV	66
6B.15 Removing the Refrigeration System.....	67
6B.15.1 Condenser Assembly	67
6B.15.2 Defrost Troubleshooting.....	67

Table of Contents

7. General Wiring Diagrams	69
7.1 Refrigerator (Off-Cycle Defrost) 115 Volt.....	69
8. Part Number Index	70
8.1 Catalog Index	70
9. Warranty Information	72
NOTES	73

1. Introduction

Traulsen provides this manual as an aid to the service technician in installation, operation, and maintenance. When used properly, this service manual can help the service technician maintain, troubleshoot, and diagnose the majority of issues that may occur. While we believe that most aspects of service are covered in this manual, should you encounter a condition not addressed, please contact:

ITW Refrigeration
Traulsen
4401 Blue Mound Road
Fort Worth, Texas 76106

Attn: Service Department
Call for Technical Support:
Tel: **(800) 825-8220**
Email: **service@traulsen.com | p19parts@traulsen.com**

IMPORTANT: To improve your service communication experience, be sure to have the following available when contacting technical support:

- Serial Number**
- Model Number**
- A detailed description of the issue**

1.1 The Serial Tag



		4401 Blue Mound Rd. Ft. Worth, TX 76106 800-825-8220	
MODEL:			SCAN FOR SERVICE INFO
MODELO:			
S/N:			
REFRIGERANT / REFRIGERANTE / RÉFRIGÉRANT			
SYS1 (REFM):			
Hi Press. (PRESH):			
Lo Press. (PRESL):			
SYS2 (REFA):			
Hi Press. (PRESH):			
Lo Press. (PRESL):			
Input Power (ELIN) - FOR INDOOR USE ONLY			
(Symbol 1) (Alt Safety / Other 1)	(Symbol 2) (Alt. San / Other 2)	(Symbol 3) (Alt. En. / Other 3)	(Symbol 4) (WEEE)
(Symbol 5) (Safety)	(Symbol 6) (Sanitation)	(Symbol 7) (Energy)	(Symbol 8) (Customer QR Code / Other 4)
Device/Part Number: PartNum		(UL/NSF Notes)	
COMPONENTS / COMPOSANTS / COMPONENTES			
COMP AMPS:		EVAP FAN AMPS:	
COND FAN AMPS:		LIGHT WATTS:	
DEF HTR AMPS:		CTRL AMPS:	
DOOR HTR AMPS:		MIN AMPS:	
MAX AMPS:			
370-60297-00 REV.A 11/20/14			

Fig. 1.1
SAMPLE
SERIAL
TAG

1.2 Serial Tag & Location

The serial tag is a permanently affixed label on which is recorded vital electrical and refrigeration data about your Traulsen product, as well as the model and serial number. This tag is in the upper left interior compartment of all Even Thaw refrigerator and freezer models.

1.2.1 Reading the Serial Tag

- Model** = The model number of your Traulsen unit
- Serial (S/N)** = The permanent ID number of your Traulsen unit
- Refrigerant SYS1** = System 1 refrigerant type used and refrigerant charge
- Design Pressure** = System 1 high and low pressure
- Refrigerant SYS2** = System 2 refrigerant type used and refrigerant charge
- Design Pressure** = System 2 high and low pressure
- Volts** = Voltage
- Hz** = Cycle
- PH** = Phase
- Total Current** = Maximum amp draw
- Minimum Circuit Amps** = Minimum circuit ampacity
- Lights** = Light wattage
- Agency Labels** = Designates agency listings
- Components** = Component ratings

NOTE: Design pressure is the maximum pressure system components can handle and NOT the operating pressure.

1.3 Understand Milk Cooler Model Numbers

- R** - Stainless Steel inside and out
- MC** - Milk Cooler
- 34, 49 or 58** - Width of Milk Cooler
- D or S** - Double or Single Access
- 4 or 6** - Caster Height

R	MC	WIDTH	ACCESS	CASTER SIZE
R-SERIES	MILK COOLER	34	S= SINGLE ACCESS	4= 4 INCH CASTER
R-SERIES	MILK COOLER	49	D= DOUBLE ACCESS	6= 6 INCH CASTER
R-SERIES	MILK COOLER	58		

All parts are optional, based on make/model
(Part Numbers are subject to change)

1.4 Reading Traulsen Serial Number

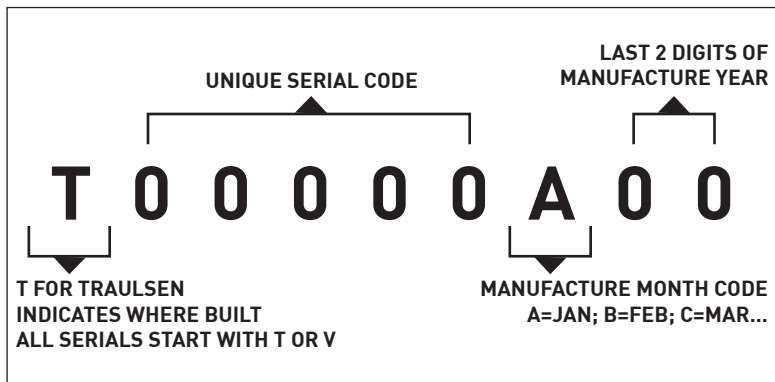

Fig. 1.4a
FORMAT IF MANUFACTURED BEFORE APRIL 2021

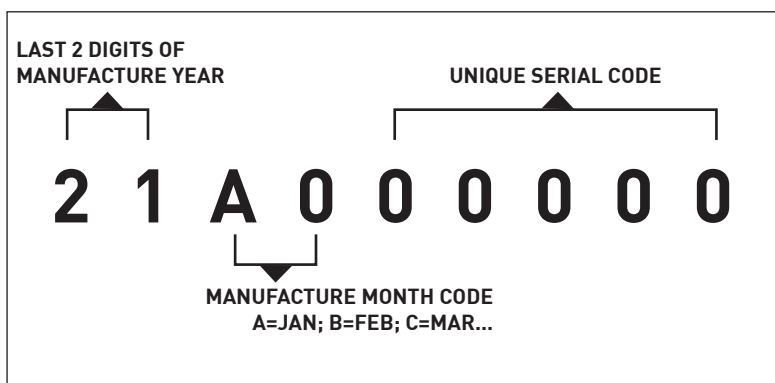

Fig. 1.4b
FORMAT IF MANUFACTURED AFTER APRIL 2021

1.5 Refrigerants

1.5.1 Terminology

Zeotropic Blend = A mixture of two or more refrigerants that have different boiling points that evaporate or condense together. All 400 series refrigerants are zeotropic blends.

Azeotropic Blend = A mixture of two or more refrigerants that boil at the same temperature so that they evaporate and condense together. All 500 series refrigerants are azeotropic blends.

Temperature Glide = The temperature difference between the the starting and ending temperature of a refrigerant phase change within a system at a constant pressure. This can be seen on a Pressure Temperature chart as the difference between bubble and dew temperatures.

Fraction of Refrigerant = The change in composition of a blend because one or more of the components is lost or removed faster than the others.

Bubble Point = The temperature at which the liquid of a refrigerant blend starts to boil.

Dew Point = The temperature at which the vapor of a refrigerant blend starts to condense.

Superheat = The heat added to a refrigerant after its saturation point or heat added after a refrigerant boils

Subcooling = The heat removed from a refrigerant after its saturation point or heat removed after a refrigerant condenses.

- GWP: 3
- Refrigerant can be charged from either the liquid and vapor phase
- A-Gas refrigerant cylinders have dual port valves, making liquid off take easier
- Flammable and low toxicity with a safety classification of A3
- Compressors can be charged with a variety of oils contact the compressor manufacturer for more information
- Excellent thermodynamic properties leading to high energy efficiency
- Due to its flammable nature R290 (Propane) requires different charging, recovery procedures and equipment

Formula = R290 refrigerant has a chemical formula of C₃H₈, denoting its composition of three carbon atoms and eight hydrogen atoms per molecule.

Molecular Weight (g/mol) = With a molecular weight of 44.1 grams per mole, R290 is relatively lightweight, facilitating its use in refrigeration systems.

Boiling Temperature °F (°C) = R290 has a low boiling temperature of -43.8°F (-42.1°C), making it effective for cooling applications, especially in low-temperature environments.

Global Warming Potential (GWP) = With a GWP of 3, R290 is considered a low-impact refrigerant in terms of its contribution to global warming, aligning with environmentally conscious practices.

Ozone Depletion Potential (ODP) = R290 has an ozone depletion potential of 0, indicating that it does not harm the ozone layer, thus supporting efforts to preserve the Earth's atmosphere.

Appearance = This refrigerant appears as a colorless, liquefied compressed gas, allowing for easy identification and handling.

Odor = R290 is odorless, ensuring that its presence is not detectable by smell, which can be advantageous in various applications.

Solubility in Water = With a solubility of 0.0244 grams per liter, R290 exhibits limited solubility in water, which can be relevant for understanding its behavior in different environments.

Vapor Pressure = R290 operates at a vapor pressure of 109 pounds per square inch gauge (psig), influencing its performance and behavior within refrigeration systems.

Flash point = The flash point of R290 is -104°C (-155°F), indicating the temperature at which it can ignite in the presence of an ignition source, emphasizing the importance of proper handling and safety precautions.

By presenting these details in a user-friendly manner, users can better understand the characteristics and implications of utilizing R290 refrigerant in their systems.

1.5.2 R-290 (PROPANE) Refrigerant

R-290 (Propane) refrigerant is a refrigerant Traulsen uses in both low and medium temperature applications. This refrigerant is a single constituent refrigerant having no temperature glide.

Pressure (psig)	Temperature (°F)
5	-31.5
10	-21.3
15	-12.7
20	-5.1
25	1.7
30	7.9
35	13.6
40	18.9
50	28.4
60	36.9
70	44.6
80	51.6
90	58.1
100	64.2
110	69.9
130	75.2
140	80.3
150	85.2
160	89.8
170	94.2
180	98.4
190	102.4
200	106.4
210	110.1
220	113.8
230	117.3
240	120.7
250	124.0
260	127.3
270	133.4

Table 1.5.2
PRESSURE/TEMPERATURE CHART
FOR R-290 REFRIGERANT

NOTE: Use the Dew temperatures when calculating superheat and bubble temperatures when calculating subcooling.



The refrigerant R290 (Propane) is flammable and it must be handled only by competent and responsible operators, under the conditions specified. In the safety regulations in force.

R290 (Propane) is a flammable and explosive gas. Like other refrigeration systems, a unit charged with R290 is not serviceable at a consumer level. The use of special tools and proper procedures performed by licensed, trained and qualified professionals is required.

1.5.3 Troubleshooting Guide

Before calling for service, please check the following:

- Is the electrical cord plugged in?
- Is the fuse OK or circuit breaker on?
- Clean condenser coil?
- Is the power switch on?

If after checking the above items and the unit is still not operating properly, please contact an authorized Traulsen service agent. A complete list of authorized service agents was provided along with your Traulsen unit. If you cannot locate this, you may also obtain the name of a service agent from the Tech Service page at traulsen.com. If service is not satisfactory, please contact our in-house service department at: Traulsen

4401 Blue Mound Road
Fort Worth, TX 76106
800.825.8220

Traulsen reserves the right to change specifications or discontinue models without notice.

1.6 Shipping and Assembly

1.6.1 Location

Select a proper location for your Traulsen unit, away from extreme heat or cold. Allow enough clearance between the unit and the side wall in order to make use of the door stay open feature at 120° (self-closing feature operates up to 90°). The door(s) must be able to open a minimum of 90° in order to make use of the maximum clear door width available.

1.6.2 Packaging

All Traulsen units are shipped from the factory bolted to a sturdy wooden pallet and packaged in a durable cardboard container. The carton is attached to the wooden skid with the use of large staples. These should first be removed to avoid scratching the unit when lifting off the crate.

Most exterior stainless steel surfaces have a protective vinyl covering to prevent scratching during manufacturing, shipping and installation. After the unit is installed in place of service, remove and discard the covering from all surfaces.

To remove the wooden pallet, first if at all possible, we suggest that the cabinet remain bolted to the pallet during all transportation to the point of final installation. The bolts can then be removed with a 3/4" socket wrench. Avoid laying the unit on its front, side or back for removal of the pallet.

NOTE: DO NOT LAY THE UNIT ON ITS SIDE DURING

1.6.3 Installing Legs or Casters

6" High stainless steel legs are supplied standard for all Traulsen reach-in and pass-thru units. Casters in lieu of legs are available as an optional accessory for the same models. These are shipped from the factory packed inside a cardboard box which is strapped to one of the shelves. Remove the nylon strap and open the box, it should contain either four (4) legs or four (4) casters and sixteen (16) bolts.

⚠ WARNING THE CABINET MUST BE BLOCKED AND STABLE BEFORE INSTALLING LEGS OR CASTERS.

To install the legs or casters, first raise and block the reach-in a minimum of 7" from the floor. For installing legs, thread the legs into the threaded holes on the bottom of the cabinet. Be certain that all legs are tightly secured (legs and casters should be tightened to 300 inch/pounds, max). When the unit is set in its final position, it is important for proper operation that the unit be level. The legs are adjustable for this purpose; turn the bottom of the leg counter-clockwise to raise it, clockwise to lower it. Level the unit from front to back as well as side to side in this manner, using a level placed in the bottom of the cabinet.

Please note that Traulsen units are not designed to be moved while on legs. If the unit requires moving, a pallet jack or forklift should be used to prevent damage. For installing casters, the casters are "plate" type, and require the use of four (4) bolts each to secure them firmly to the cabinet bottom at each corner. The caster bolts are tightened using a 1/2" socket wrench.

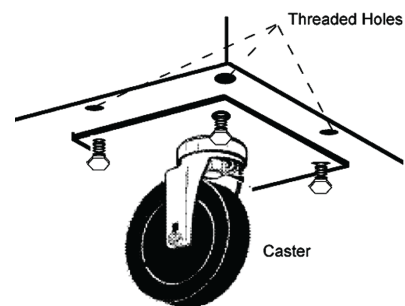
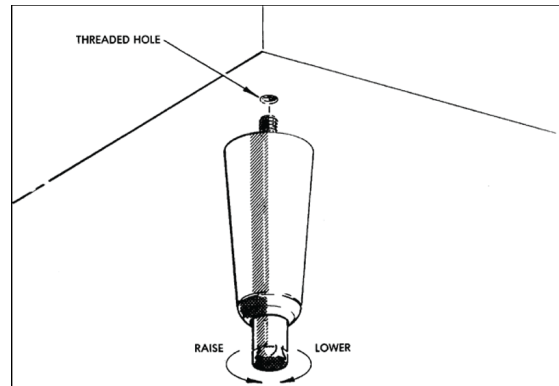

1.6.4 Cord & Plug

Most self-contained models are supplied with a cord & plug attached. It is shipped coiled at the top of the cabinet, secured by a nylon strip. For your safety and protection, all units supplied with a cord and plug include a special three-prong grounding plug on the service cord. Select only a dedicated electrical outlet with grounding plug for power source.

NOTE: Do not under any circumstances, cut or remove the round grounding prong from the plug, or use an extension cord.

1.6.5 Power Supply

The supply voltage should be checked prior to connection to be certain that proper voltage for the cabinet wiring is available (refer to the serial tag to determine correct unit voltage). Make connections in accordance with local electrical codes. Use qualified electricians.

Use of a separate, dedicated circuit is required. Size wiring to handle indicated load and provide necessary over current protector in circuit (see amperage requirements on the unit's serial tag).

1.6.6 Wiring Diagram

Refer to the wiring diagram for any service work performed on the unit. Should you require one, please contact Traulsen Service at **(800) 825-8220**, and provide the model and serial number of the unit involved.

1.6.7 Cleaning the Exterior

Exterior stainless steel should be cleaned with warm water, mild soap and a soft cloth. Apply with a dampened cloth and wipe in the direction of the metal grain.

Avoid the use of strong detergents and gritty, abrasive cleaners as they may tend to mar and scratch the surface. Do NOT use cleansers containing chlorine, this may promote corrosion of the stainless steel.

Care should also be taken to avoid splashing the unit with water, containing chlorinated cleansers, when mopping the floor around the unit.

For stubborn odor spills, use baking soda and water (mixed to a 1 TBSP baking soda to 1 pint water ratio).

1.6.8 Cleaning the Interior

For cleaning both stainless steel and anodized aluminum interiors, the use of baking soda as described in section "1.6.13" is recommended. Use on breaker strips as well as door gaskets. All interior fittings are removable without tools to facilitate cleaning.

1.6.9 Temperature control

The temperature is set at the factory but local conditions may necessitate slight adjustment.

1.6.10 Top Door Latch

To adjust the latch on the top door turn the safety screw on each side clockwise to tighten and counter-clockwise to loosen.

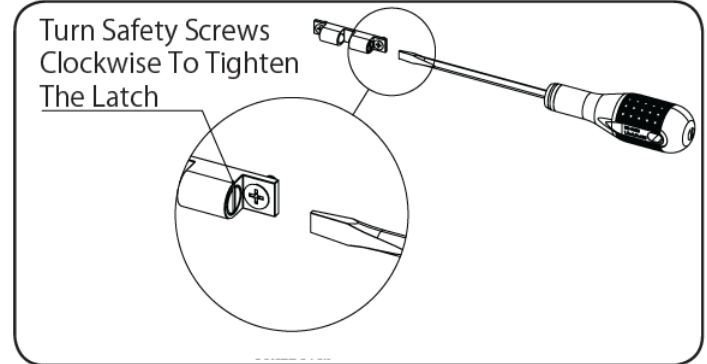

1.6.11 Troubleshooting Guide Chart

PROBLEM	POSSIBLE SOLUTION
1. Condensing unit fails to start.	a. Check if cord & plug has been disconnected. b. Clean Condenser.
2. Condensing unit operates for prolonged periods or continuously.	a. Are doors closed properly? b. Dirty condenser or filter. Clean properly. c. Evaporator coils iced. Needs to defrost.
3. Milk compartment is too warm. (NOTE: Compressor may be cycling ON/OFF frequently)	a. Check door(s) and gasket(s) for proper seal. b. Check if a large quantity of warm milk was recently added or the door was kept open for a long period of time. c. Clean Condenser.
4. Milk compartment is too cold.	a. Check if a large quantity of very cold or frozen milk has recently been added. Allow adequate time for the cabinet to recover its normal operating temperature.
5. Condensation on exterior surface.	a. Check door(s) alignment and gaskets for proper seal. b. Condensation on the exterior surface of the unit is perfectly normal during periods of high humidity.

1.6.12 Troubleshooting Guide

Before calling for service, please check the following:

Is the electrical cord plugged in?

Is the fuse OK or circuit breaker on?

Clean condenser coil?

Is the power switch on?

If after checking the above items and the unit is still not operating properly, please contact an authorized Traulsen service agent. A complete list of authorized service agents was provided along with your Traulsen unit. If you cannot locate this, you may also obtain the name of a service agent from the Tech Service page at traulsen.com. If service is not satisfactory, please contact our in-house service department at: Traulsen

4401 Blue Mound Road
Fort Worth, TX 76106
800.825.8220

Traulsen reserves the right to change specifications or discontinue models without notice.

1.6.13 Service Information

To purchase replacement parts or to speak to service support for Traulsen and most Hobart Refrigeration units please contact our Ft. Worth facility by phone at 800.825.8220 or fax to 817.740.6748 (parts) or 817.740.6757 (service).

To obtain other service information you may log onto:

1. traulsen.com

2. Select Service & Parts Tab (upper right of screen)

3. Select one of the following: Service Finder, Service Parts Manuals, Parts Pricing & Warranty Registration

NOTE: When calling for service support, please make sure you have model and serial number of unit available.

1.7 Specifications

DIMENSIONS	Single Access Cabinet	Double Access Cabinet
Height - Overall on 4" Casters	46" (116.8 cm)	46" (116.8 cm)
Length	58" (147.3 cm)	58" (147.3 cm)
Depth	32-1/8" (81.6 cm)	34-1/4" (87 cm)
Net weight uncrated lbs. (Kg)	23.37	46.5

Table 1.7
TRAULSEN CABINET SPECIFICATIONS

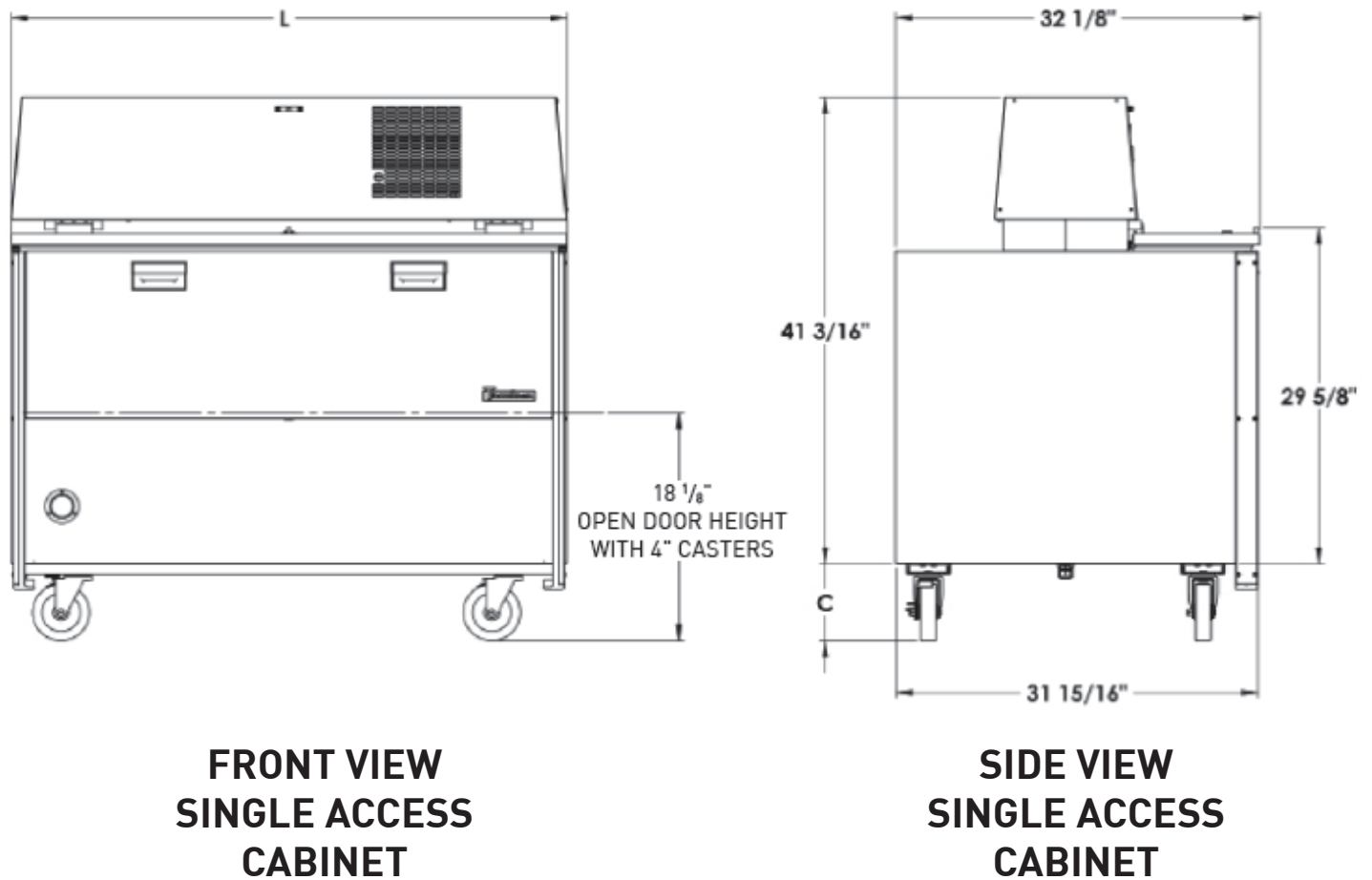
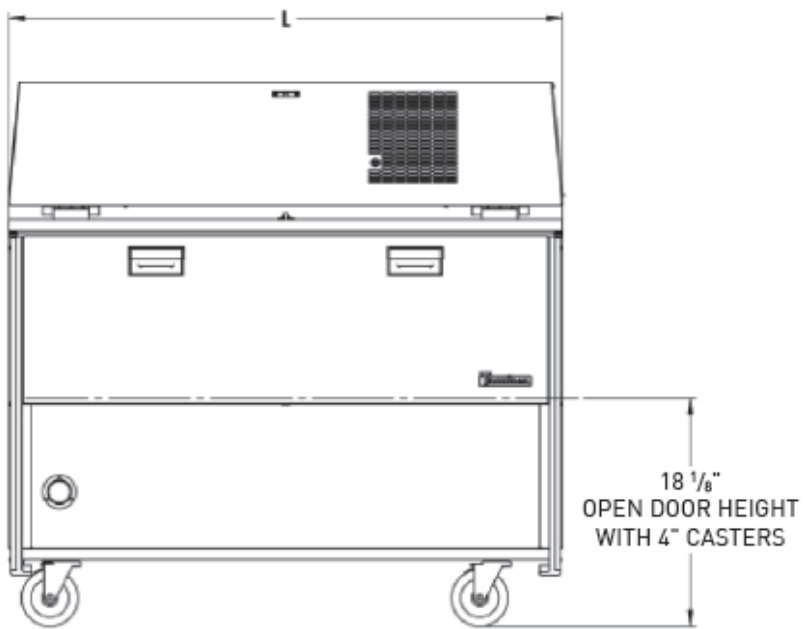
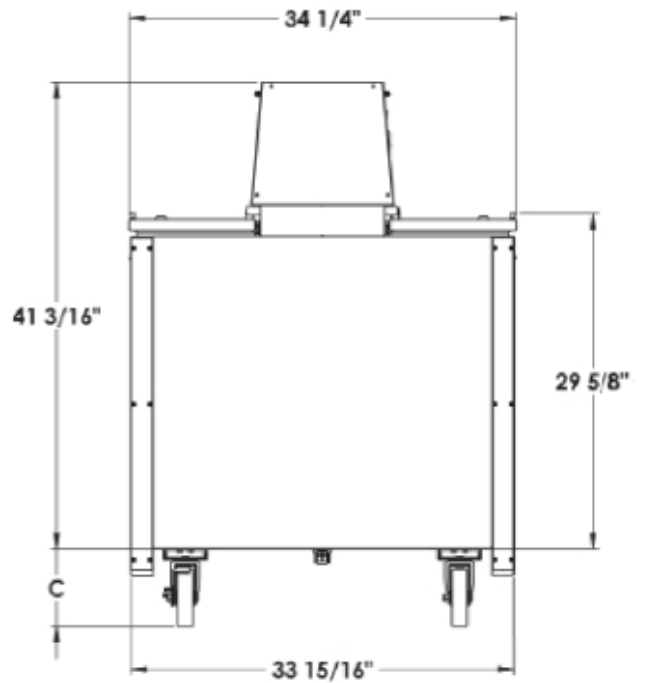

Fig. 1.7a
SINGLE ACCESS CABINET



**FRONT VIEW
DOUBLE ACCESS
CABINET**



**SIDE VIEW
DOUBLE ACCESS
CABINET**

Fig. 1.7b
DOUBLE ACCESS CABINETS

2. Preventive Maintenance

This section is to inform the recommended preventive maintenance (PM) procedures. Depending on application, PM schedule may vary.

2.1 Inspect & Clean Unit:

Why	Sanitation & prolong cabinet life	
Frequency	Daily	
Time required	3 minutes to prepare	3 minutes to complete
Preparation	Have a soft cloth. Baking soda & water mixed to a 1 TBSP (15mL) baking soda to 1 pint (473.2mL) water ratio.	
Cleaning	Apply with a dampened cloth, wipe in the direction of the metal grain. (Avoid the use of strong detergents and gritty, abrasive cleaners as they may tend to mar and scratch the surface. Do NOT use cleansers containing chlorine; this may promote corrosion of the stainless steel.)	
Inspection	Visually inspect the unit for signs of wear that may require repair.	

Table 2.1
CLEANING PM PROCEDURE

2.2 Inspect & Clean Door Gasket:

Why	Long reliable service life
Frequency	Every 3 months
Time required	10 minutes to complete
Inspection	Open cabinet door(s) to inspect gasket. Pull gasket with hand & visually inspect gasket for tears, dirt, mold or wear. Clean with mild soap & water. Do NOT use cleaners containing chlorine or chlorides. Replace as needed. 341-60256-00 - Full-Height Gasket 341-60257-00 - Half-Height Gasket

Table 2.2
DOOR GASKET CLEANING PM PROCEDURE

2.3 Clean Condenser Coil:

⚠ WARNING Disconnect electrical power supply before cleaning any parts of the unit.

Why	Long reliable service life, extended compressor life	
Frequency	Every 3 months	
Time required	5 minutes to prepare	15 minutes to complete

Table 2.3a
CONDENSER CLEANING PM PROCEDURE

INSPECTING EVAPORATOR COIL DRAIN PAN & DRAIN:

Clear out any debris. Spray water on coil to ensure drain pan is flowing out of the drain.

Preparation

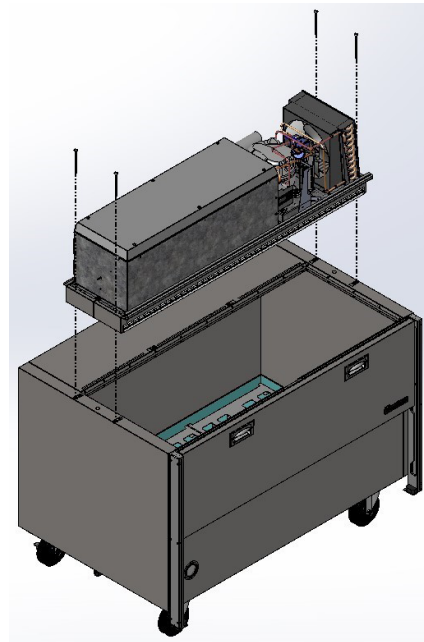
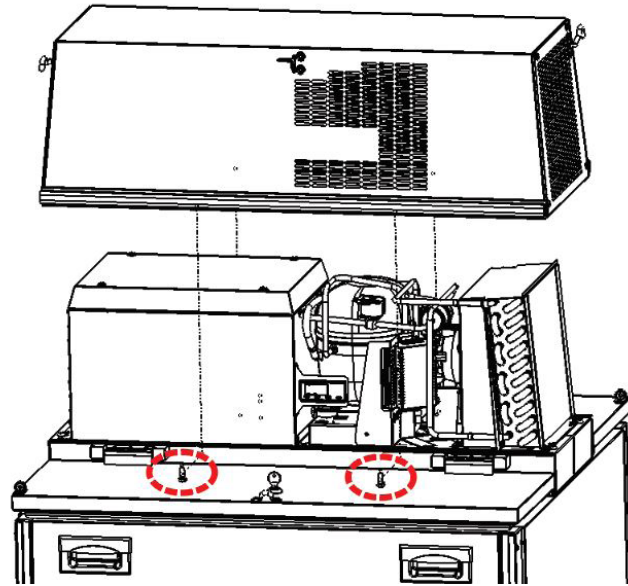

To clean the condenser, first disconnect electrical power to the cabinet and lift the top hump assembly. To lift this, remove the two screws located on both sides at the bottom of the hump assembly. Once the screws are removed, the panel can be lifted upwards allowing full access to the front-facing condenser.

Cleaning

Use a soft bristle brush to remove any dirt, lint or dust from the finned condenser coil, around the compressor and other cooling system parts as indicated. Be sure to brush in the direction of the fins to prevent damage. If significant dirt is clogging the condenser fins, use compressed air to blow this clear. When finished, reverse the hump assembly removal process as instructed above. **Compressor warranty claims will not be paid for units with dirty condensers.**

Table 2.3b
CONDENSER CLEANING PM PROCEDURE

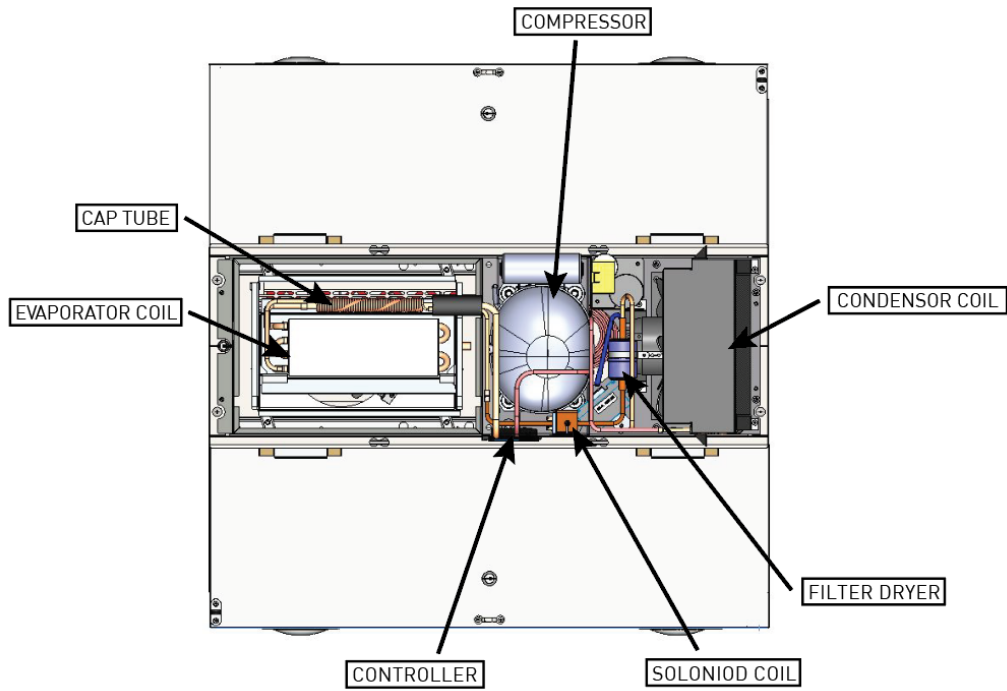

Fig. 1.6f
R-450 SYSTEM TOP VIEW
For systems build 2010-
2023

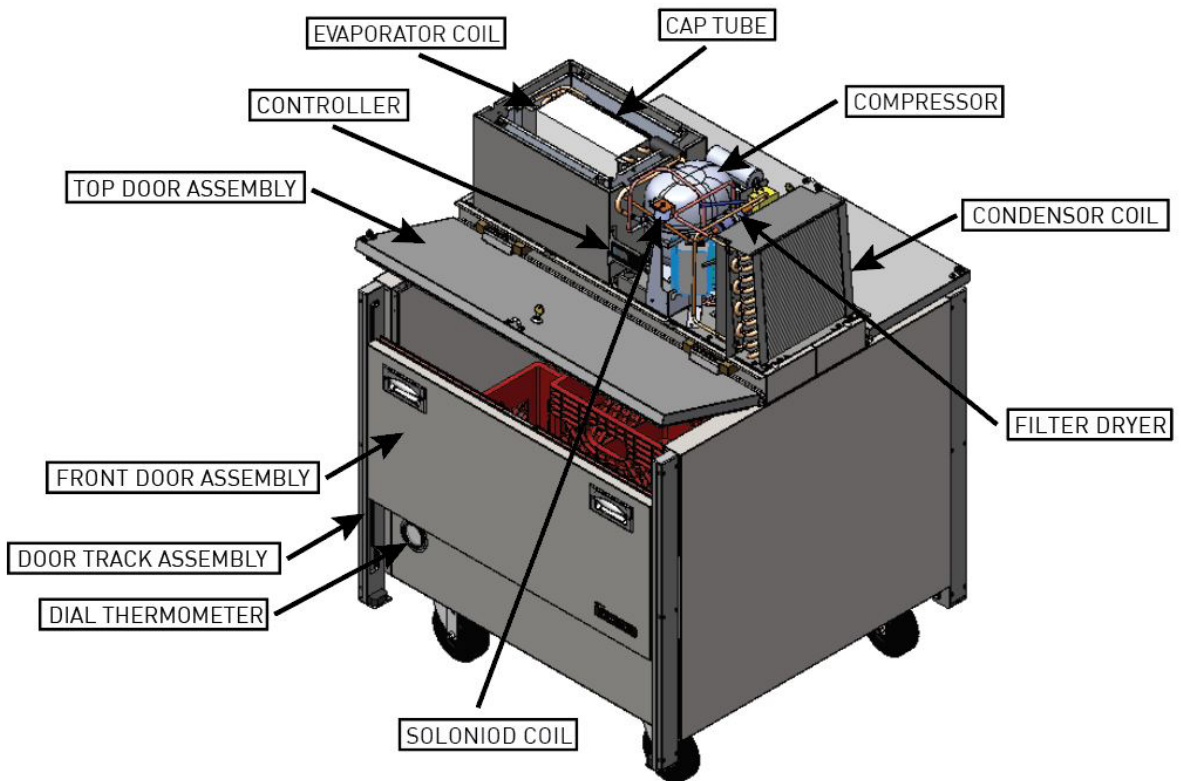

Fig. 1.6f
R-450 SYSTEM ISO VIEW

3. Doors & Hardware

3.1 Hinges

3.1.1 Removing the Doors and Hardware:

To fit through narrow (less than 35") doorways, it may be necessary to remove the door(s), and/or hinges. To remove any solid door, begin by removing the safety screw at the bottom of the top hinge which secures the door in place. Remove this with a #2 Phillips screwdriver and the door can then be lifted off the hinges. After removing the door, it may be necessary to remove the hinge assembly and hardware from the door itself. If it is necessary to remove the hinge hardware from the cabinet, begin by removing the (3) Phillips-head screws which hold it in place. Set these components aside for later reassembly. Pay special attention not to lose the door switch actuator button.

The lock keeper may also require removal to reduce the overall cabinet depth to 32".

First remove the lock keeper strike plate by removing the (2) Phillips-head screws which secure it in place- exposing the adjustment screws. Then remove both adjustment screws from the mounting plate. To reinstall the door and/or hinges, please reverse the appropriate sections of the preceding procedure.

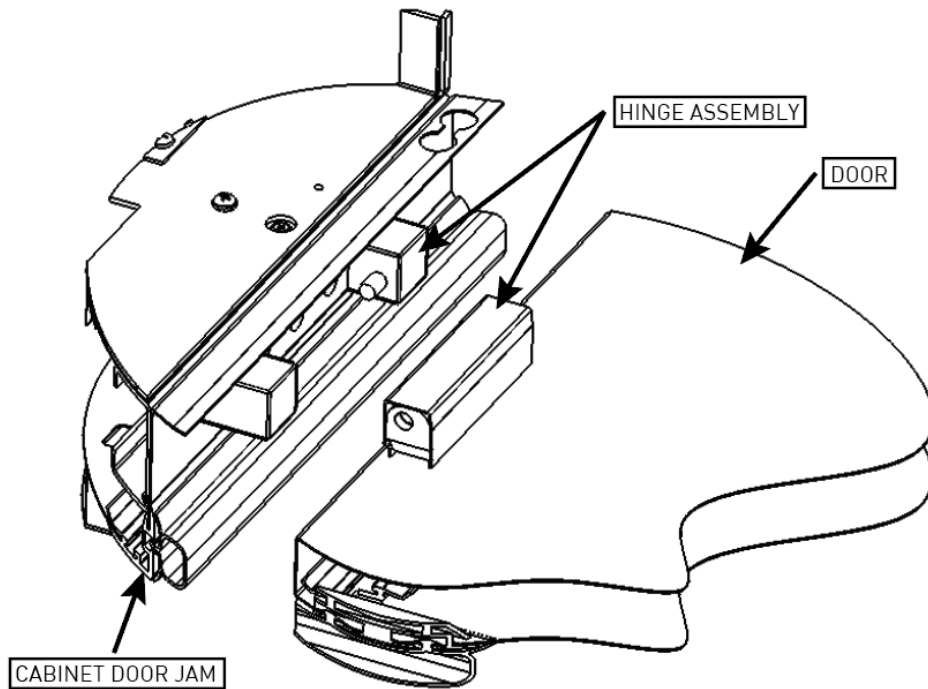

Fig. 3.1a
HINGE ASSEMBLY

WARNING

WHEN REMOVING DOORS ENSURE THEY ARE SET ASIDE IN A SECURE POSITION TO PREVENT FALL/SLIP THAT MAY CAUSE PERSONAL INJURY.

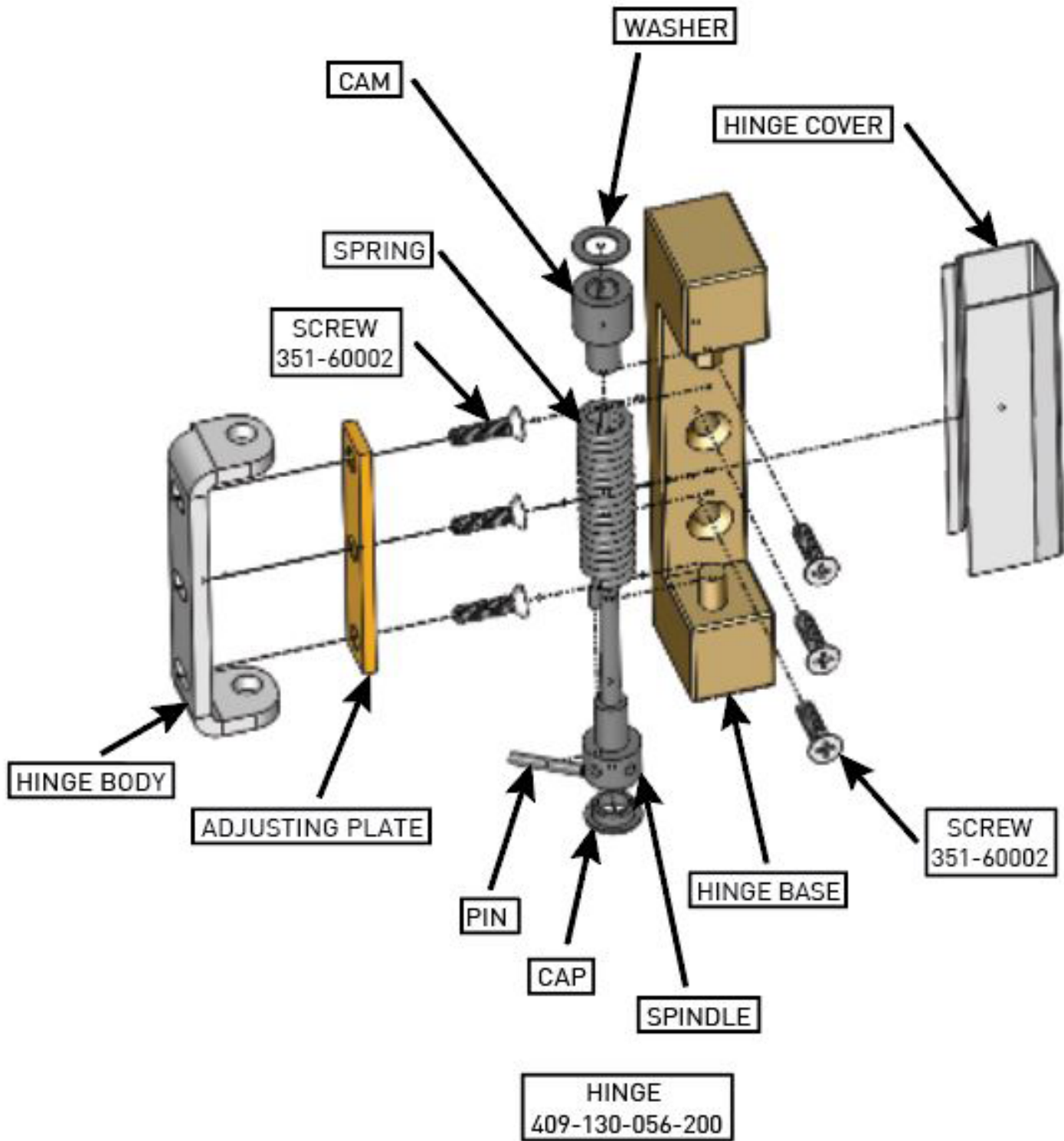

Fig. 3.1b
HINGE EXPLODED VIEW

3.2 EZ-Clean Gaskets

Door Gasket Replacement:

Remove an old gasket by grasping it firmly by one corner and pull it out. Install the new gasket by inserting all (4) corners first. After the corners are properly inserted, work your way towards the center from both ends- pushing the dart into the retainer until the gasket is completely seated in place. Check for a proper seal all the way around the door.

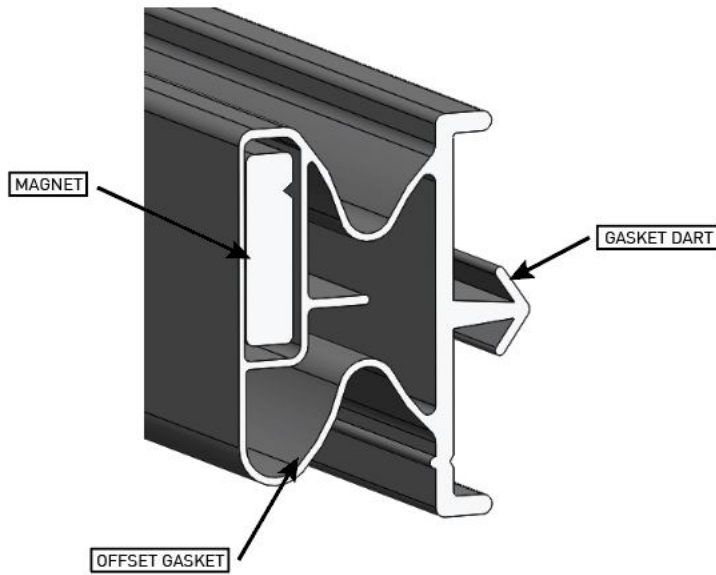

Fig. 3.2A
FRONT DOOR EASY CLEAN GASKET,
SECTION VIEW

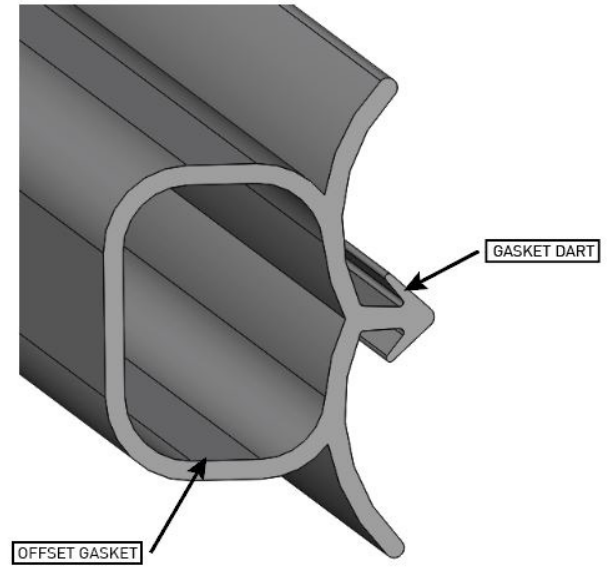

Fig. 3.2B
TOP DOOR ASSY LID GASKET, SECTION VIEW

Description	Part Number	Unit
Fig. 3.3A - FRONT DOOR EASY CLEAN GASKET	341-60262-00	RMC34
Fig. 3.3B - TOP DOOR ASSY LID GASKET	341-60267-01	RMC34, RMC49
SLIDING DOOR	341-60262-01	RMC49
ASSY LID	341-60267-02	RMC58
ASSY SLIDING DOOR	641-60262-02	RMC58

Table 3.2c
DOOR GASKET PART NUMBERS

3.3 Locks

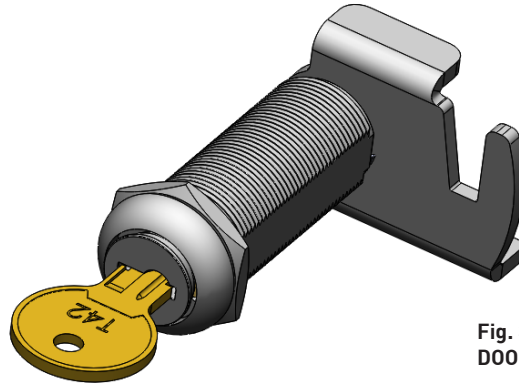

Fig. 3.3
DOOR LOCK VIEW

3.3.1 Door Lock Assembly Exploded View

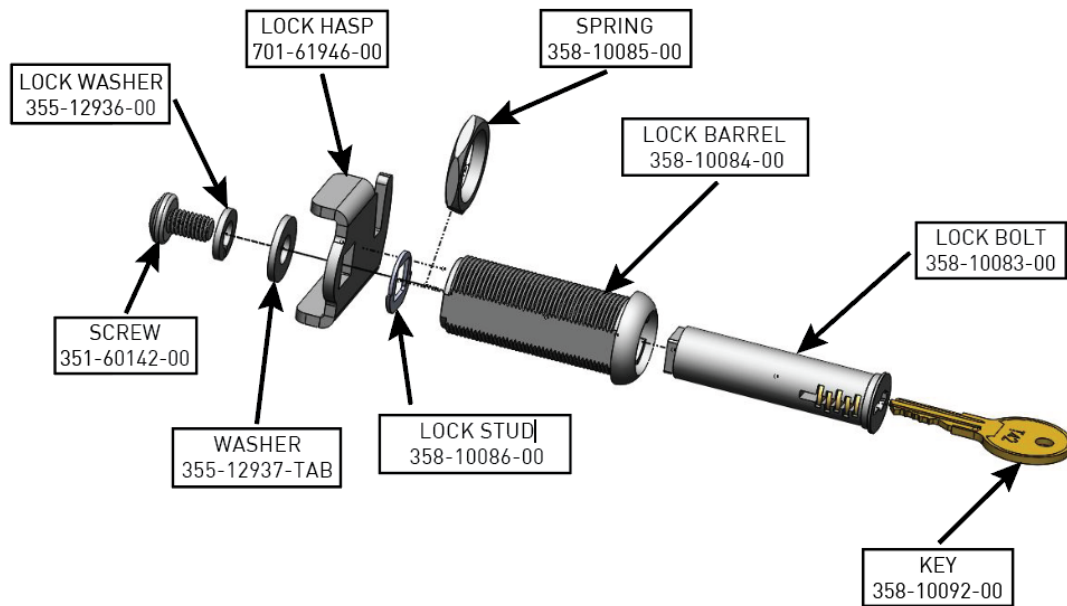
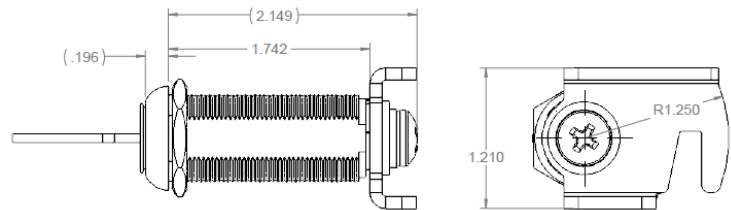

Fig. 3.3.1
DOOR LOCK EXPLODED VIEW



NOTE: Core removal key should only be used to remove door lock assembly. A damaged Hudson lock barrel requires door replacement.

Cam Lock Assembly	358-10089-011
-------------------	---------------

Table 3.3
DOOR LOCK SERVICE KIT PART NUMBERS

Service Kit Numbers:

3.3.2 Door Lock Replacement Instructions

Disassembly of Lock:

To remove the lock cylinder for replacement, insert the core removal key into the lock- causing the spline to lower so the lock cylinder can be removed. Move the key up & down, then pull backwards; the core key will pull the lock cylinder along with it. The lock bolt is now free to slide out of the lock barrel for replacement (if applicable).

Assembly of Lock:

Insert the lock bolt into the lock barrel until the groove in the bolt is approximately in the locked position. Insert the core removal key into the lock cylinder (causing the spline to lower) and insert the lock cylinder into the lock barrel (**NOTE: Lock stud must be lined up with lock bolt groove**). Use one hand to firmly hold the lock cylinder in place, then remove the core key with the other (causing spline to rise & securing lock cylinder).

NOTE: Lock barrel is assembled to the door during production at the factory. A damaged lock barrel requires door replacement. Core removal key should only be used for lock replacement. Use of core removal key to lock & unlock the door will cause the lock cylinder to fall out.

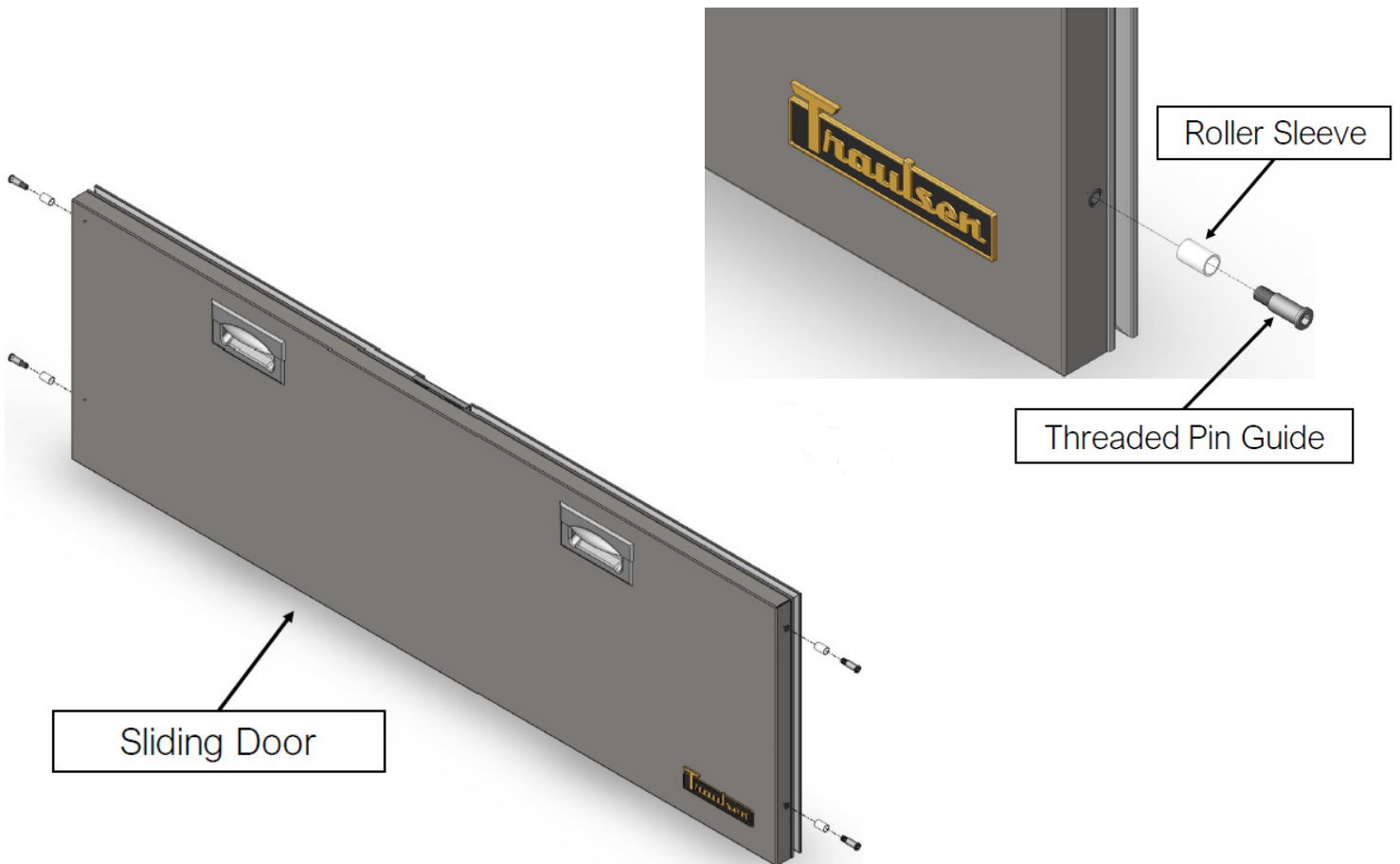

4. Controls

4.1 Control Cover Removal & Components

4.1.1 Removing the Display

Remove bottom louver screws & rotate louver up out of the way. Disconnect cable from the back of the controller. Lastly, squeeze the (4) tabs holding on the back side of the display & push outward to remove the display.

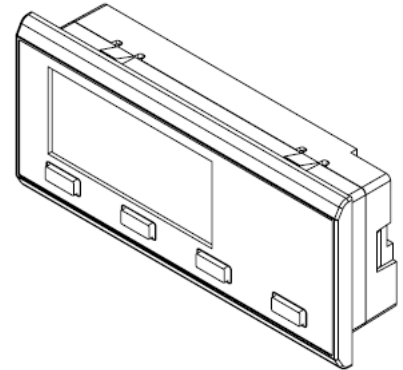

4.1.2 Installing the Display

Line up the display with the cutout on the cabinet. Firmly press the (4) outside corners (do not press the center) of the controller into the cabinet until the (4) tabs click into place. Make sure to reconnect the cable to the display.

NOTE: Do not press on the center of the display during installation to avoid causing damage.

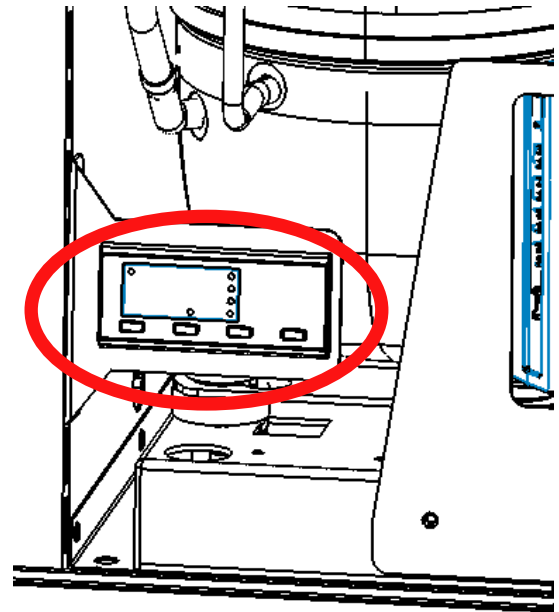
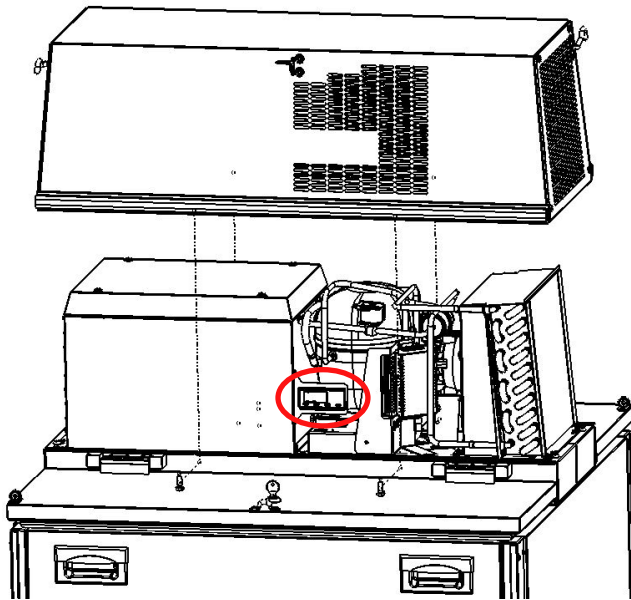

Fig. 4.1.2 DISPLAY
PART # 950-60561-00

4.2 Control basics

Your new Milk Cooler is equipped with a digital control, which precisely regulates operation. It is supplied from the factory completely ready for use and is located next to the refrigeration system underneath the cover.

4.3 Information Menu

The information available in this menu is:

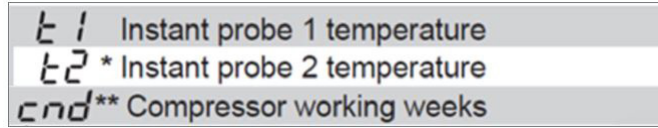

* Displayed only if enabled (see Configuration Parameters)

** Displayed only if ACC → 0

Access to menu and information displayed:

- Press and immediately release button **i**.
- With button **▼** or **▲** select the data to be displayed.
- Press button **i** to display value.
- To exit from the menu, press button **✕** or wait for 10 seconds.

Initiate Stand-By:

Keeping the button **⏻** pressed for 3 seconds allows the controller to be put on a standby or output control to be resumed (with SB=YES only).

Locking the Keypad:

The keypad lock avoids undesired, potentially dangerous operations, which might be attempted when the controller is operating in a public place. In the INFO menu, set parameter **LOC** = YES to inhibit all functions of the buttons. To resume normal operation of keypad, adjust setting so that **LOC** = NO.

4.4 Adjusting Cabinet Setpoint

Setpoint display and modification:

Adjust Setpoint:

- Press button for **i** second to display setpoint value
- Keeping the **i** button pressed use **▼** or **▲** buttons to set the desired value
- When **i** button is released the new value is stored
- Press button **i** for at least a half second to display the setpoint value.
- While keeping the **i** button pressed, use button **▼** or **▲** to set the desired value (adjustment is within the minimum **SPL** and the maximum **SPH** limit).
- When button **i** is released, the new value is stored.

4.5 Initiating a Defrost

Automatic defrost:

Defrost starts automatically as soon as the time set with parameter **DFT** has elapsed.

- Timed defrost: With **DFM** = TIM defrosts take place at regular intervals when the timer reaches the value of **DFT**. For example, with **DFM** = TIM and **DFT** = 36, a defrost will take place every 6 hours.
- Optimized defrost: With **DFM** = FRO the timer is only increased when the conditions occur for frost to form on the evaporator, until the time set with parameter **DFT** is matched. If the evaporator works at 0°F, defrost frequency depends on the thermal load and climatic conditions. With setpoints much lower than 0°F, defrost frequency mainly depends on the milk cooler operating time.
- Defrost time count backup: At the power-up, if **DFB** = YES, the defrost timer resumes the time count from where it was left off before the power interruption. Vice versa, with **DFB** = NO, the time count re-starts from 0. In stand-by, the accumulated time count is frozen.

Manual or remote defrost start:

It's possible to manually start a defrost, by pressing button **⏻** for 2 seconds.

Defrost type. Once defrost has started, Compressor and Defrost outputs are controlled according to parameter **DTY**. If **FID** = YES, the evaporator fans are active during defrost.

Defrost termination. The actual defrost duration is influenced by a series of parameters.

- Time termination: **T2** = NO and **T3** different from 2EU: the evaporator temperature is not monitored and defrost will last as long as time **DTO**.
- Temperature monitoring of one evaporator: **T2** = YES and **T3** different from 2EU. In this case, if the sensor **T2** measures the temperature **DLI** before the time **DTO** elapses, defrost will be terminated in advance.











Resuming thermostatic cycle:

When defrost is over, if **DRN** is greater than 0, all outputs will remain off for **DRN** minutes, in order for the ice to melt completely and the resulting water to drain. Moreover, if probe **T2** is active (**T2** = YES), the fans will re-start when the evaporator gets to a temperature lower than **FDD**; Vice versa, if probe **T2** is not active (**T2** = NO) or after defrost has come to an end, such condition does not occur by end of the time **FTO**, after **FTO** minutes have elapsed the fans will be switched on anyway.

Caution: if **DFM** = NON or **C-H** = HEA all defrost functions are inhibited; if **DFT** = 0, automatic defrost functions are excluded.

4.6 Configuration Parameters

Parameter Configuration:

- To get access to the parameter configuration menu, press button  and  for 5 seconds.
- With button  or  select the parameter to be modified.
- Press button  to display the value.
- By keeping button  pressed, use button  or  to set the desired value.
- When button  is released, the newly programmed value is stored and the following parameter is displayed.
- To exit from the setup, press button  or wait for 30 seconds.

4.7 Technical Data

Power supply

TRL-002....W 100-240Vac ±10%, 50/60Hz, 3W

Relay output max loads (240Vac)

	TRL-002..S/T..-	TRL-002..Q/R..-
Compressor	16A resistive 12 FLA 48 RLA	12A resistive 12 FLA 48 RLA
Evap. Fan	16A resistive 4 FLA 12 RLA	"8A resistive 4 FLA 12 RLA"
Defrost	16A resistive 4 FLA 12	16A resistive 4 FLA 12 RLA
Auxiliary loads 1	7A resistive	7A resistive
Auxiliary loads 2	7A resistive	7A resistive

Input

NTC 10KΩ@25°C LAE Part No. SN4...

Measurement Range

←0.5 within the measurement range

Operating Conditions

-10... +50°C; 15%...80% r.H.

CE (Approvals and Reference Norms)

EN60730-1; EN60730-2-9; EN55022 (Class B); EN50082-1

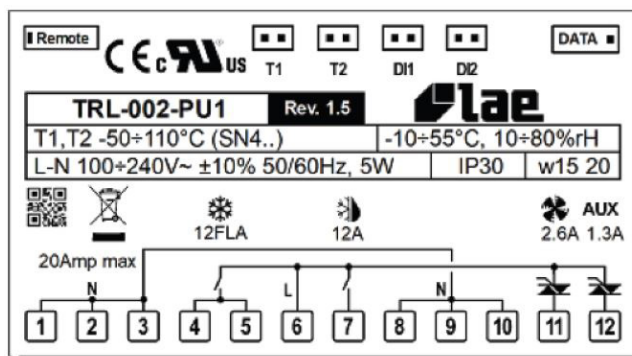

Fig. 4.7 CONTROL WIRING DIAGRAM

PAR	RANGE	DESCRIPTION
SPL	-58..SPH	Minimum limit for SP setting.
SPH	SPL...180°	Maximum limit for SP setting.
SP	SPL... SPH	Setpoint (value to be maintained in the room).
C-H	REF; HEA	Refrigerating (REF) or Heating (HEA) control mode.
HY0	1...10°	Thermostat OFF → ON differential.
HY1	0...10°	Thermostat ON → OFF differential.
CRT	0...30 min	Compressor rest time. The output is switched on again after CRT minutes have elapsed since the previous switchover. We recommend to set CRT=03 with HY0←-2.0°.
CT1	0...30 min	Compressor/Heater output run when probe T1 is faulty. With CT1=0 the output will always remain OFF.
CT2	0...30 min	"Compressor/Heater output stop when probe T1 is faulty. With CT2=0 and CT1→0 the output will always be ON. Example: CT1=4, CT2= 6: In case of probe T1 failure, the compressor will cycle 4 minutes ON and 6 minutes OFF."
DFM	NON; TIM; FRO CRN	"Defrost start mode NON : defrost function is disabled (the following parameter will be FCM). TIM : regular time defrost. FRO : the defrost time count is only increased when the conditions occur for frost to form on the evaporator (optimized time increase). CRN : defrost is based off of compressor run time (time is based off of DAT)."
DFT	0...250	Time interval among defrosts in x10 minutes. When this time has elapsed since the last defrost, a new defrost cycle is started. Each number is multiplied by 10 minutes. 0-250 indicates 0-2500 minutes.
DAT	"0...100 hours"	Frost accumulation timeout.
DFB	NO/YES	Defrost timer backup. With DFB=YES, after a power interruption, the timer resumes the count from where it was left off with ±30 min. approximation. With DFB=NO, after a power interruption, the defrost timer will re-start to count from zero.
DLI	-58...180°	Defrost end temperature.
DMD	0...30 min	Minimum defrost duration.
DTO	1...120 min	Maximum defrost duration.
DTY	OFF; ELE; GAS	"Defrost type OFF: off cycle defrost (Compressor and Heater OFF). ELE: electric defrost (Compressor OFF and Heater ON). GAS: hot gas defrost (Compressor and Heater ON)."
DSO	OFF; LO; HI	"Defrost start optimization OFF : no optimization. LO : defrost waits until the compressor cut-out. HI : defrost waits until the compressor cut-in."
SOD	0...30 min	Start optimization delay.
DPD	0...240 sec	Evaporator pump down. At the beginning of defrost, defrost outputs (determined by DTY) are OFF for DPD seconds.
DRN	0...30 min	Pause after defrost (evaporator drain down time).
DDM	"RT; LT; SP; DEF"	"Defrost display mode. During defrost the display will show: RT : the real temperature; LT : the last temperature before defrost; SP : the current setpoint value; DEF : "dEF"."

PAR	RANGE	DESCRIPTION
DDY	0...60 min	Display delay. The display shows the information selected with parameter DDM during defrost and for DDY minutes after defrost termination.
FID	NO/YES	Fans active during defrost.
FDD	-58...180°	Evaporator fan re-start temperature after defrost.
FTO	0...120 min	Maximum evaporator fan stop after defrost.
FCM	NON; TMP; TIM	“Fan mode during thermostatic control. NON : The fans remain ON all the time; TMP : Temperature-based control. The fans are ON when the compressor is ON. When the compressor is turned OFF, the fans remain ON as long as the temperature difference $T_e - T_a$ is greater than FDT. The fans are turned ON again with FDH differential. (T_e = Evaporator temperature, T_a = Air temperature); TIM : Timed-based control. The fans are ON when the compressor is ON. When the compressor is OFF, the fans switch ON and OFF according to parameters FT1, FT2,FT3”
FDT	-12...0°	Evaporator-Air temperature difference for the fans to turn OFF after the compressor has stopped.
FDH	1...12°	Temperature differential for fan re-start.
		Example: FDT = -1, FDH=3. In this case, after the compressor has stopped, the fans are OFF when $T_e \rightarrow T_a - 1$ (FDT), whereas the fans are ON when $T_e \leftarrow T_a - 4$ (FDT-FDH).
FT1	0...180 sec	Fan stop delay after compressor/heater stop. See Fig. 2
FT2	0...180	Timed fan stop in x10 seconds. With FT2=0 the fans remain on all the time.
FT3	0...180	Timed fan run in x10 seconds. With FT3=0, and FT2 \rightarrow 0, the fans remain off all the time.
ATM	NON; ABS; REL	“Alarm threshold management. NON : all temperature alarms are inhibited (the following parameter will be ACC). ABS : the values programmed in ALA and AHA represent the real alarm thresholds. REL : the alarm threshold is obtained by the sum of setpoint, thermostat differential and ALR/ AHR.”
ALA	-58... 180°	Low temperature alarm threshold.
AHA	-58... 180°	High temperature alarm threshold.
ALR	-12... 0°	Low temperature alarm differential. With ALR=0 the low temperature alarm is excluded.
AHR	0... 12°	High temperature alarm differential. With AHR=0 the high temperature alarm is excluded.
ATI	T1; T2; T3	Probe used for temperature alarm detection.
ATD	0... 120 min	Delay before alarm temperature warning.
ACC	0...52 weeks	Condenser periodic cleaning. When the compressor operation time, expressed in weeks, matches the ACC value programmed, “CL” flashes in the display. With ACC=0 the condenser cleaning warning is disabled and CND disappears from Info Menu.
IISM	NON; MAN; ECO; DI	“Switchover mode to second parameter set NON : inhibition to use the second parameter group (the following parameter will be SB). MAN : button switches the two parameter groups over. ECO : automatic switchover to the second parameter group, when ECO conditions are detected. DI : switchover to the second parameter group when DIx input is on.”
IISL	-58... IISH	Minimum limit for IISP setting.

PAR	NGE	ON
IISH	IISL... 180°	Maximum limit for IISP setting.
IISP	IISL... IISH	Setpoint in mode 2.
IIH0	1... 10°	Thermostat OFF-->ON differential in mode 2.
IIH1	0... 10°	Thermostat ON-->OFF differential in mode 2.
IIDF	0...250	Time interval among defrosts in mode 2 in x10 minutes.
IIFC	"NON; TMP; TIM"	Fan control in mode 2. See FCM.
ECS	1...5	Controller sensitivity for the automatic switchover from Group I to Group II (1=minimum, 5=maximum).
ECS	1...5	Controller sensitivity for the automatic switchover.
EPT	0...240 min	Eco pull-down time. Only with IISM=ECO. Group I parameters are used in regulation for at least EPT minutes. See Fig.3
SB	NO/YES	Stand-by button enabling.
DSM	NON; ALR; STP	"Door switch input mode: NON : door switch inhibited ALR : when Dlx=DOR and the digital input is on, an alarm is generated after ADO minutes STP : when Dlx=DOR and the digital input is on, in addition to the alarm, the fans are immediately stopped and the compressor is stopped after CSD minutes."
DAD	0...30 min	Delay before door open alarm warning.
CSD	0...30 min	Compressor/heater stop delay after door has been opened.
D10	NON; DOR; ALR; IISM; RDS	"D11 digital input operation NON : digital input 1 not active. DOR : door input. ALR : when the input is on, an alarm is generated (if AHM=STP, the compressor is stopped and the defrosts are suspended). IISM : when the input is on, the controller will use group 2 parameters. RDS : when the input is on, a defrost is started (remote control)."
D1A	OPN; CLS.	"D11 digital input activation. OPN : on open CLS : on close"
D20	See D10	DI2 digital input operation. See D10.
D2A	OPN; CLS.	"DI2 digital input activation. OPN : on open CLS : on close"
PSL	-58...158	Minimum setpoint adjusted via potentiometer.
PSR	0...15	Range of setpoint adjusted via potentiometer.
LSM	"NON; MAN; ECO; DI1; DI2; DI3."	"Light control mode NON : light output not controlled. MAN : light output controlled through button (if OAx=LGT). ECO : lights activated/deactivated following the ECO state. Dlx : lights activated/deactivated following the Dlx state."
LSA	OPN; CLS	"Light activation (only with LSM=ECO or LSM=Dlx). OPN : lights on with Dlx open or ECO mode deactivated. CLS : lights on with Dlx closed or ECO mode activated."
OT1	0...600 sec	Activation time of OA1

PAR	RANGE	DESCRIPTION
OT2	0...600 sec	Pause between OA1 activation
OA1	“NON; LGT; 0-1; 2CU; 2EU; ALO; ALC”	“AUX 1 output operation NON : output disabled (always off). LGT : output enabled for light control. 0-1 : the relay contacts follow the on/standby state of controller. 2CU : output programmed for the control of an auxiliary compressor. 2EU : output enabled for the control of the electrical defrost of a second evaporator. ALO : contacts open when an alarm condition occurs. ALC : contacts make when an alarm condition occurs.”
2CD	0...120 sec	Auxiliary compressor start delay. If OAx=2CU the auxiliary output is switched on with a delay of 2CD seconds after the main compressor has cut-in. Both compressors are turned off at the same time.
OS1	-12.5..12.5°	Probe T1 offset.
T2	NO/YES	Probe T2 enabling (evaporator).
OS2	-12.5..12.5°	Probe T2 offset.
T3	NON; DSP; CND; 2EU	“Auxiliary probe T3 operation NON : probe T3 not fitted. DSP : temperature T3 to be displayed. CND : condenser temperature measurement. 2EU : second evaporator temperature measurement.”
OS3	-12.5..12.5°	Probe 3 offset.
AHM	NON; ALR; STP;	“Operation in case of high condenser alarm NON : high condenser alarm inhibited. ALR : in case of alarm, “HC” flashes in the display and the buzzer is switched on. STP : in addition to the alarm symbols displayed, the compressor is stopped and defrosts are suspended.”
AHT	-50...110°	Condensation temperature alarm (referred to T3 probe).
TLD	1...30 min	Delay for minimum temperature (TLO) and maximum temperature (THI) logging.
TDS	T1; 1-2; T3	“Selects the temperature probe to be displayed. T1 : probe T1 1-2 : the AVG-weighted average between T1 and T2 T3 : probe T3”
AVG	0...100%	“The relative weight of T2 on T1 (if TDS = 1-2) Example 1: T1 = -5°, T2 = -20°, AVG = 100%. The displayed temperature will be -20° (T1 has no effect) Example 2: T1 = -5°, T2 = -20°, AVG = 60%. The displayed temperature will be -14.”
SCL	“1°C; 2°C; °F”	“Readout scale. 1°C : measuring range -50...110°C (0.1°C resolution within -9.9 ÷ 19.9°C interval, 1°C outside) 2°C : measuring range -50 ... 110°C °F : measuring range -55 ... 180°F”
SIM	0...100	Display slowdown.
ADR	1...255	TRL-002 address for PC communication.
NPR	0...1	Setup programmed.
STT	0...255	Setup traceability.

4.8 Temperature Reading Calibration

This service manual provides instructions for accurately testing temperature sensors within an Traulsen Milk Cooler refrigeration system by immersing them in an ice bath at precisely 32°F.

Procedure:

Ice Bath Preparation:

Fill a suitable container with an 80% ice to 20% water ratio to create an ice bath with a consistent temperature of 32°F.

Dipping the Sensor Bulb:

Locate the bulb of the temperature sensor that requires testing.

Submerge the sensor bulb fully into the ice bath, ensuring complete immersion.

Viewing Control Value:

Monitor the control value displayed on the testing equipment. If the temperature does not read 32°F, proceed to the next step.

Measuring Resistance:

If the control value deviates from 32°F, measure the resistance of the sensor using appropriate equipment.

The expected resistance at 32°F should be 27.22 Kiloohms.

Sensor Identification:

T1-Grey Sensor (Return Air):

Locate the T1-Grey sensor situated in the return air duct. This sensor is critical for monitoring the air temperature before it enters the HVAC system.

T2-Blue Sensor (Evaporator Coil):

Identify the T2-Blue sensor positioned in the evaporator coil. This sensor plays a vital role in monitoring the coil temperature to ensure efficient cooling.

Conclusion:

Testing temperature sensors in an ice bath at 32°F is essential for maintaining HVAC system functionality. By following the procedures outlined in this manual, technicians can effectively evaluate sensor performance and ensure accurate temperature readings for optimal system operation.

5. Sensor Location

This section is an overview of the various sensors located throughout the cabinet.

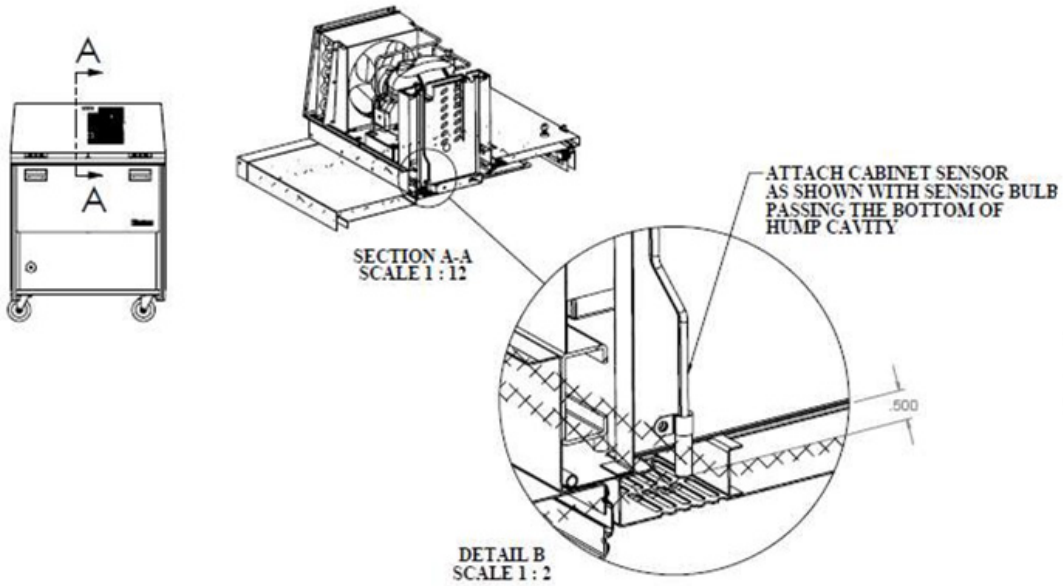
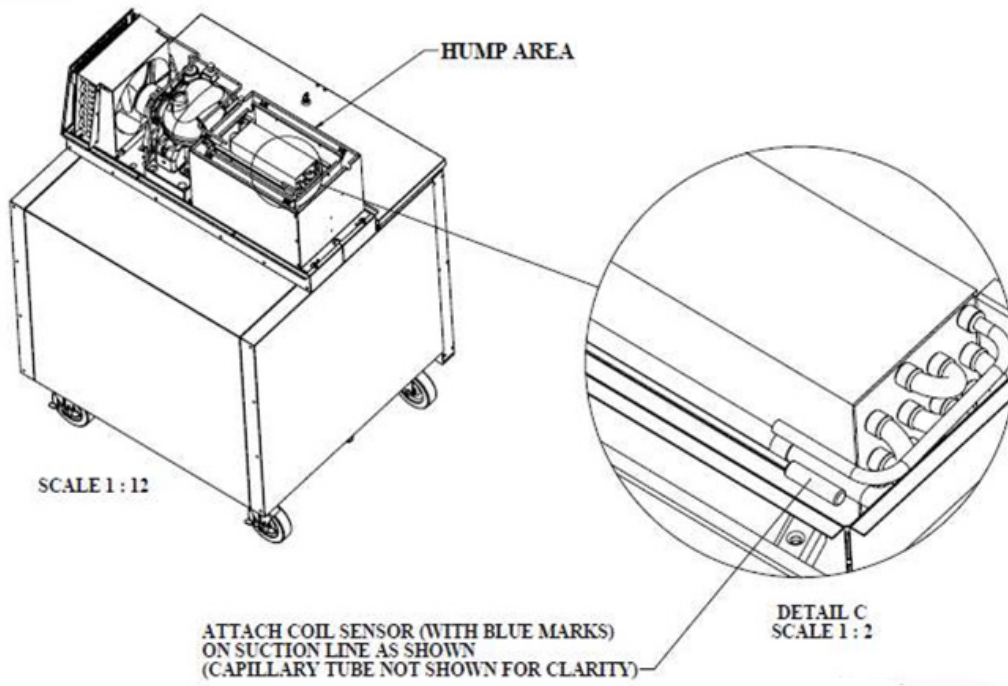

5.1 Sensor Resistance Test

To check if the sensor is reading accurately:

- Place sensor bulb in a glass of ice with a little bit of water in it (32°F)
- Use Ohm meter to test resistance. At 32°F resistance should be 27.22KΩ.

Resistance Curve:

<u>Resistance Curve:</u>			
Temp C	Resistance K Ohms	Resistance Ohms	Temp F
-40.0	195.767	195767.0	-40.0
-25.0	87.596	87596.0	-13.0
-20.0	68.263	68263.0	-4.0
-15.0	53.667	53667.0	5.0
-10.0	42.518	42518.0	14.0
-5.0	33.900	33900.0	23.0
0.0	27.224	27224.0	32.0
5.0	22.025	22025.0	41.0
10.0	17.928	17928.0	50.0
15.0	14.675	14675.0	59.0
20.0	12.081	12081.0	68.0
25.0	10.000	10000.0	77.0
30.0	8.314	8314.0	86.0

Table 5.1 RESISTANCE TEST CURVE

6. UL/IEC/CE

6A.1 Electrical outputs for refrigerant detection system

The device shall have an output to indicate the presence of a refrigerant concentration exceeding the set point.

The REFRIGERANT SENSORS and controls shall be configured such that a failure of the controls or sensor turns on the indoor fan to deliver Q_{min} or greater as defined in Annexes GG and 101.DVG. For ADD-ON HEATPUMPS a failure of the REFRIGERANT SENSOR or controls shall turn on the indoor fan at the highest available speed or to not less than Q_{min} as determined in Annex GG.

Vibration requirements of IEC 60079-29-1 for fixed gas detection sensors need not apply to the entire appliance.

6A.2 Refrigerant detection system self-test routine

The refrigerant detection system shall include a means for self-testing to determine if a REFRIGERANT SENSOR or sensing element malfunction has occurred. The self-test shall include missing REFRIGERANT SENSOR (open circuit), by-passed REFRIGERANT SENSOR (shorted circuit), and REFRIGERANT SENSOR output out of range.

The test shall be run at least every hour, and if a failure is detected, the device shall take the actions in accordance with Clause 6.1

If the REFRIGERANT SENSOR is a LIMITED LIFE REFRIGERANT SENSOR and requires replacement after a given period, then the device shall take the actions prescribed in Clause 6.1 at the end of the specified life and shall provide indication that replacement is required. Compliance is checked by inspection.

6A.3 Serviceability

REFRIGERANT SENSORS shall be accessible for inspection, and replacement. REFRIGERANT SENSORS for replacement shall be specified by the appliance manufacturer.

6A.4 Refrigerant Sensor identification

The REFRIGERANT SENSORS shall be marked or tagged with

- A) name, trademark, or identification mark of the manufacturer or responsible vendor;
- B) reference number or other means for identifying the refrigerant sensor; and
- C) "This refrigerant sensor shall only be replaced with manufacturer approved sensor". If the SENSOR is only replaceable as part of an assembly of parts, then the assembly shall be marked.

6A.5 Qualification of workers

To minimize the risk of possible ignition due to improper service or incorrect parts. Servicing shall only be carried out by factory authorized service personnel certified to work on refrigeration systems containing flammable refrigerants.

EPA Section 608

Certified Refrigeration Service Technician (CRST)

6A.6 Information on servicing

6A.6.1 Checks to the area



This appliance is marked with the ISO 7010-W021 warning label to indicate the presence of FLAMMABLE REFRIGERANTS. Prior to beginning work on systems containing FLAMMABLE REFRIGERANTS, safety checks are necessary to ensure the risk of ignition is minimized. For repair to the REFRIGERATING SYSTEM, follow the instructions outlined in sections 6A.6.2 to 6A.6.5 prior to conducting work on the system.

Verifying refrigerant is important for the safe and efficient operation of HVAC systems. Refrigerant testing can help identify contaminants like moisture, acid, and particulate matter, which can damage equipment and compromise performance. It can also help identify leaks, which can lead to refrigerant loss and environmental damage.

Minimum Floor Area Requirements:

Regulatory Basis:

- Safety standards for flammable refrigerants dictate that to avoid creating hazardous concentrations of gas in case of a leak, the refrigerant must be diluted in a sufficiently large room.
- The minimum floor area of 7.1 square meters ensures that in the event of a leak, the concentration of R290 does not reach flammable levels.

Specific Requirements:

Ventilation:

- The room where the unit is installed must be well-ventilated to prevent the accumulation of flammable gas.
- Proper ventilation helps disperse any leaked refrigerant, reducing the risk of reaching a flammable concentration.

Location Restrictions:

- The unit must not be installed in lobbies or corridors. These areas typically have higher foot traffic, and placing flammable refrigerants there could pose a greater risk to public safety.
- Restricting installation to less trafficked areas reduces potential ignition sources and the number of people exposed to risk.

Practical Implications:

For Installers and Users:

- When installing units with R290 refrigerant, professionals must ensure that the room meets the minimum floor area requirement of 7.1 square meters.
- Additionally, they must verify that the space has adequate ventilation and is not a high-traffic area like a lobby or corridor.

Compliance with Standards:

- Adhering to these regulations helps ensure compliance with international safety standards, which is crucial for legal and insurance purposes.
- It also enhances safety for end-users by minimizing the risk of accidents associated with refrigerant leaks.

Minimum
Ventilation Area
7.1m²

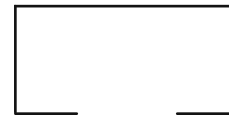

By understanding and following these requirements, stakeholders can ensure the safe and effective use of R290 refrigerant in refrigeration systems, balancing environmental benefits with necessary safety precautions.

6A.6.2 Work procedure

Work shall be undertaken under a controlled procedure so as to minimize the risk of a flammable gas or vapor being present while the work is being performed.

6A.6.3 General work area

All maintenance staff and others working in the local area shall be instructed on the nature of work being carried out. Work in confined spaces shall be avoided.

6A.6.4 Checking for presence of refrigerant

The area shall be checked with an appropriate refrigerant detector prior to and during work, to ensure the technician is aware of potentially toxic or flammable atmospheres. Ensure that the leak detection equipment being used is suitable for use with all applicable refrigerants, i.e., non sparking, adequately sealed, or intrinsically safe.

6A.6.5 Presence of fire extinguisher

If any hot work is to be conducted on the refrigerating equipment or any associated parts, appropriate fire extinguishing equipment shall be available on hand. A dry chemical or CO2 fire extinguisher should be adjacent to the charging area.

6A.6.6 No ignition sources

No person carrying out work in relation to a REFRIGERATING SYSTEM which involves exposing any pipe work shall use any sources of ignition in such a manner that it may lead to the risk of fire or explosion. All possible ignition sources, including cigarette smoking, should be kept sufficiently far away from the site of installation, repairing, removing and disposal, during which refrigerant can possibly be released to the surrounding space. Prior to work taking place, the area around the equipment shall be surveyed to make sure that there are no flammable hazards or ignition risks. "No Smoking" signs shall be displayed.

6A.6.7 Ventilated area

Ensure that the area is in the open or that it is adequately ventilated before breaking into the system or conducting any hot work. A degree of ventilation shall continue during the period that the work is carried out. The ventilation should safely disperse any released refrigerant and preferably expel it externally into the atmosphere.

6A.6.8 Checks to the refrigerating equipment

Where electrical components are being changed, they shall be fit for the purpose and to the correct specification. At all times, the manufacturer's maintenance and service guidelines shall be followed. If in doubt, consult the manufacturer's technical department for assistance.

The following checks shall be applied to installations using FLAMMABLE REFRIGERANTS:

- A) the actual REFRIGERANT CHARGE is in accordance with the room size within which the refrigerant containing parts are installed;
- B) the ventilation machinery and outlets are operating adequately and are not obstructed;
- C) if an indirect refrigerating circuit is being used, the secondary circuit shall be checked for the presence of refrigerant;
- D) marking to the equipment continues to be visible and legible. Markings and signs that are illegible shall be corrected;
- E) refrigerating pipe or components are installed in a position where they are unlikely to be exposed to any substance which may corrode refrigerant containing components, unless the components are constructed of materials which are inherently resistant to being corroded or are suitably protected against being so corroded.

6A.6.9 Checks to electrical devices

Repair and maintenance to electrical components shall include initial safety checks and component inspection procedures. If a fault exists that could compromise safety, then no electrical supply shall be connected to the circuit until it is satisfactorily dealt with. If the fault cannot be corrected immediately but it is necessary to continue operation, an adequate temporary solution shall be used. This shall be reported to the owner of the equipment, so all parties are advised.

Initial safety checks shall include:

- A) that capacitors are discharged: this shall be done in a safe manner to avoid possibility of sparking;
- B) that no live electrical components and wiring are exposed while charging, recovering or purging the system;
- C) that there is continuity of earth bonding.

6A.7 Repairs to sealed components

During repairs to sealed components, all electrical supplies shall be disconnected from the equipment being worked upon prior to any removal of sealed covers, etc. If it is absolutely necessary to have an electrical supply to equipment during servicing, then a permanently operating form of leak detection shall be located at the most critical point to warn of a potentially hazardous situation.

Particular attention shall be paid to the following to ensure that by working on electrical components, the casing is not altered in such a way that the level of protection is affected. This shall include damage to cables, excessive number of connections, terminals not made to original specification, damage to seals, incorrect fitting of glands, etc.

Ensure that the apparatus is mounted securely.

Ensure that seals or sealing materials have not degraded to the point that they no longer serve the purpose of preventing the ingress of flammable atmospheres. Replacement parts shall be in accordance with the manufacturer's specifications.

6A.8 Repair to intrinsically safe components

Do not apply any permanent inductive or capacitive loads to the circuit without ensuring that this will not exceed the permissible voltage and current permitted for the equipment in use.

Intrinsically safe components are the only types that can be worked on while live in the presence of a flammable atmosphere. The test apparatus shall be at the correct rating.

Replace components only with parts specified by the manufacturer. Other parts can result in the ignition of refrigerant in the atmosphere from a leak.

NOTE The use of silicon sealant can inhibit the effectiveness of some types of leak detection equipment. Intrinsically safe components do not have to be isolated prior to working on them.

6A.9 Cabling

Check that cabling will not be subject to wear, corrosion, excessive pressure, vibration, sharp edges, or any other adverse environmental effects. The check shall also take into account the effects of aging or continual vibration from sources such as compressors or fans.

6A.10 Detection of flammable refrigerants

Under no circumstances shall potential sources of ignition be used in the searching for or detection of refrigerant leaks. A halide torch (or any other detector using a naked flame) shall not be used.

The following leak detection methods are deemed acceptable for all refrigerant systems. Electronic leak detectors may be used to detect refrigerant leaks but, in the case of FLAMMABLE REFRIGERANTS, the sensitivity might not be adequate, or might need recalibration. (Detection equipment shall be calibrated in a refrigerant-free area.) Ensure that the detector is not a potential source of ignition and is suitable for the refrigerant used. Leak detection equipment shall be set at a percentage of the LFL of the refrigerant and shall be calibrated to the refrigerant employed, and the appropriate percentage of gas (25 % maximum) is confirmed.

Leak detection fluids are also suitable for use with most refrigerants but the use of detergents containing chlorine shall be avoided as the chlorine can react with the refrigerant and corrode the copper pipe-work.

NOTE Examples of leak detection fluids are

- Bubble method,
- Fluorescent method agents.

If a leak is suspected, all naked flames shall be removed/extinguished.

If a leakage of refrigerant is found which requires brazing, all of the refrigerant shall be recovered from the system, or isolated (by means of shut off valves) in a part of the system remote from the leak. Removal of refrigerant shall be according to.

6A.11 Removal and evacuation

When breaking into the refrigerant circuit to make repairs - or for any other purpose - conventional procedures shall be used. However, for flammable refrigerants it is important that best practice be followed, since flammability is a consideration. The following procedure shall be adhered to:

- A) safely remove refrigerant following local and national regulations;
- B) purge the circuit with inert gas;
- C) evacuate;
- D) purge with inert gas;
- E) open the circuit by cutting or brazing.

The refrigerant charge shall be recovered into the correct recovery cylinders if venting is not allowed by local and national codes. For appliances containing flammable refrigerants, the system shall be purged with oxygen-free nitrogen to render the appliance safe for flammable refrigerants. This process might need to be repeated several times. Compressed air or oxygen shall not be used for purging refrigerant systems.

For appliances containing flammable refrigerants, refrigerants purging shall be achieved by breaking the vacuum in the system with oxygen-free nitrogen and continuing to fill until the working pressure is achieved, then venting to atmosphere, and finally pulling down to a vacuum. This process shall be repeated until no refrigerant is within the system (optional for A2L). When the final oxygen-free nitrogen charge is used, the system shall be vented down to atmospheric pressure to enable work to take place.

Ensure that the outlet for the vacuum pump is not close to any potential ignition sources and that ventilation is available.

6A.12 Charging procedures

In addition to conventional charging procedures, the following requirements shall be followed.

- A) Ensure that contamination of different refrigerants does not occur when using charging equipment. Hoses or lines shall be as short as possible to minimize the amount of refrigerant contained in them.
- B) Cylinders shall be kept in an appropriate position according to the instructions.
- C) Ensure that the REFRIGERATING SYSTEM is earthed prior to charging the system with refrigerant.
- D) Label the system when charging is complete (if not already).
- E) Extreme care shall be taken not to overfill the REFRIGERATING SYSTEM.

Prior to recharging the system, it shall be pressure-tested with the appropriate purging gas. The system shall be leak-tested on completion of charging but prior to commissioning. A follow up leak test shall be carried out prior to leaving the site.

6A.13 Decommissioning

Before carrying out this procedure, it is essential that the technician is completely familiar with the equipment and all its detail. It is recommended good practice that all refrigerants are recovered safely. Prior to the task being carried out, an oil and refrigerant sample shall be taken in case analysis is required prior to re-use of recovered refrigerant. It is essential that electrical power is available before the task is commenced.

- A) Become familiar with the equipment and its operation.
- B) Isolate the system electrically.
- C) Before attempting the procedure, ensure that:
 - I) mechanical handling equipment is available, if required, for handling refrigerant cylinders;
 - II) all personal protective equipment is available and being used correctly;
 - III) the recovery process is supervised at all times by a competent person;
 - IV) recovery equipment and cylinders conform to the appropriate standards.
- D) Pump down refrigerant system, if possible.
- E) If a vacuum is not possible, make a manifold so that refrigerant can be removed from various parts of the system.
- F) Make sure that cylinder is situated on the scales before recovery takes place.
- G) Start the recovery machine and operate in accordance with instructions.
- H) Do not overfill cylinders (no more than 80 % volume liquid charge).
- I) Do not exceed the maximum working pressure of the cylinder, even temporarily.
- J) When the cylinders have been filled correctly and the process completed, make sure that the cylinders and the equipment is removed from site promptly and all isolation valves on the equipment are closed off.
- K) Recovered refrigerant shall not be charged into another REFRIGERATING SYSTEM unless it has been cleaned and checked.

6A.14 Labeling

Equipment shall be labeled stating that it has been decommissioned and emptied of refrigerant. The label shall be dated and signed. For appliances containing FLAMMABLE REFRIGERANTS, ensure that there are labels on the equipment stating the equipment contains FLAMMABLE REFRIGERANT.

6A.15 Recovery

When removing refrigerant from a system, either for servicing or decommissioning, it is recommended good practice that all refrigerants are removed safely.

When transferring refrigerant into cylinders, ensure that only appropriate refrigerant recovery cylinders are employed. Ensure that the correct number of cylinders for holding the total system charge is available. All cylinders to be used are designated for the recovered refrigerant and labeled for that refrigerant (i.e., special cylinders for the recovery of refrigerant). Cylinders shall be complete with pressure-relief valve and associated shut-off valves in good working order. Empty recovery cylinders are evacuated and, if possible, cooled before recovery occurs.

The recovery equipment shall be in good working order with a set of instructions concerning the equipment that is at hand and shall be suitable for the recovery of all appropriate refrigerants including, when applicable, FLAMMABLE REFRIGERANTS. In addition, a set of calibrated weighing scales shall be available and in good working order. Hoses shall be complete with leak-free disconnect couplings and in good condition. Before using the recovery machine, check that it is in satisfactory working order, has been properly maintained and that any associated electrical components are sealed to prevent ignition in the event of a refrigerant release. Consult manufacturer if in doubt.

The recovered refrigerant shall be returned to the refrigerant supplier in the correct recovery cylinder, and the relevant waste transfer note arranged. Do not mix refrigerants in recovery units and especially not in cylinders.

If compressors or compressor oils are to be removed, ensure that they have been evacuated to an acceptable level to make certain that FLAMMABLE REFRIGERANT does not remain within the lubricant. The evacuation process shall be carried out prior to returning the compressor to the suppliers. Only electric heating to the compressor body shall be employed to accelerate this process. When oil is drained from a system, it shall be carried out safely.

6A.16 Warning Notices

This appliance is not intended for use by persons (including children) with reduced physical, sensory or mental capabilities, or lack of experience and knowledge, unless they have been given supervision or instruction concerning use of the appliance by a person responsible for their safety.

WARNING Children should be supervised to ensure that they do not play with the appliance.

This appliance is rated for use in Climatic Class 5. This appliance can operate in an environment with maximum ambient temperatures of 104° F (40° C) and 40% RH.

Product is suitable for use up to 6500 ft (2000m).

WARNING Power cord should only be replaced with a Traulsen-specified part.

WARNING Appliances that use a flammable refrigerant shall indicate that component parts shall be replaced with like components so as to minimize the risk of possible ignition due to incorrect parts.

Maximum loading per shelf is 200 lbs (91 kg)

WARNING Do not store explosive substances such as aerosol cans with a flammable propellant in this appliance.

Review all flammable refrigerant cautions for completeness.

WARNING Keep clear of any obstructions for all ventilation openings of the appliance enclosure.

WARNING Do not use mechanical devices or other means to accelerate the defrosting process, other than those recommended by the manufacturer.

WARNING Do not damage the refrigerating circuit. Do not pierce or burn.

WARNING Do not use electrical appliances inside the food/ice storage compartments unless they are of the type recommended by the manufacturer.

Taking care to avoid causing a fire by igniting flammable material.

Install in accordance with the Safety Standard for Refrigeration Systems, ANSI/ASHRAE 15.

WARNING Do not use means to accelerate the defrosting process or to clean, other than those recommended by the manufacturer.

WARNING The appliance shall be stored in a room with out continuously operating ignition sources (for example: open flames, an operating gas appliance or an operating electric heater.

WARNING Be aware that refrigerants may not contain an odor.

General precautions when working on an R-290 (propane) refrigeration system:

- Notify all persons in the immediate area that you are working with a flammable refrigerant.
- Insure the work area is well ventilated.
- Use a combustible gas monitor to measure propane concentration in the air.
- Beware of flammable materials present in the work area.
- Extinguish ignition sources within 10 feet of the work area if possible.
- Have a Class B dry powder type fire extinguisher available.
- Use spark-resistant tools.
- Use extra care while servicing the unit to avoid damage to refrigerant tubing, condenser, and evaporator coils.
- Always use appropriate PPE (Personal Protection Equipment).

Examples of ignition sources:

- A spark from an electrical source such as:
 - Contactors
 - Relay
 - Defrost heaters
 - Condensate pan heaters
 - Door switches
 - Light bulbs
 - Electrical outlets
 - Switches
 - Electrical drill
 - Static electricity
- Open flame ignition sources such as:
 - Fryers
 - Cigarettes/lighters
 - Gas appliances
 - Griddles
- Tools:
 - Non-spark resistant tools
 - Heat guns
 - Torches

6B. Troubleshooting

⚠ WARNING Certain procedures in this section require electrical tests or measurements while power is applied to the machine. Exercise extreme caution at all times. If test points are not easily accessible, disconnect power and follow lockout/tagout procedures, attach test equipment and reapply power to test.

6B.1 Additional Requirements & Precautions for Servicing R-290 (Propane) Systems

Key Terms:

Lower Explosive Limit (LEL) - The lowest concentration of a gas or vapor in the air capable of producing a flash fire in the presence of an ignition source (arc, flame, heat). A concentration lower than the LEL is not rich enough to burn. The LEL of R-290 (propane) is 2.1% concentration by volume of air.

Upper Explosive Limit (UEL) - The highest concentration of a gas or vapor in the air capable of producing a flash of fire in the presence of an ignition source (arc, flame, heat). Concentration higher than the UEL is too rich to burn. The UEL for R-290 (propane) is 9.5% concentration by volume of air.

EPA/SNAP - Environmental Protection Agency/Significant New Alternative Policy. The EPA approved the conditional use of R-290 (propane) refrigerant in new equipment in 2011.

Global Warming Potential (GWP) - A measure of the greenhouse gases' ability to trap radiant energy, with carbon dioxide assigned a value of 1. R-448A and R-450A have values of 1273 and 546 respectively. R-290 (propane) has only a value of 3.

Hydrocarbon Refrigerants (HC) - Hydrocarbon refrigerants are a select group of hydrocarbons that are non-toxic, non-ozone depleting substances that are being used to replace more traditional refrigerants.

Ozone Depletion Potential (ODP) - A measure of the refrigerant's ability to destroy stratospheric ozone. Modern HFC refrigerants such as R448-A and R-450A have an ODP of zero. Hydrocarbon refrigerants such as R-290 (propane) also have an ODP of zero.

Flash Point - Flash point is the minimum temperature at which a substance will burn with an ignition source. The flash point of R-290 (propane) is -150°F.

Auto Ignition Temperature - The auto ignition temperature is the temperature at which a fuel will ignite without the need for a spark or flame. The auto ignition temperature of R-290 (propane) is 896°F.

Well Ventilated - Any area or space where air flow can enter and exit freely.

Confined Space - Per OSHA, a confined space is defined as:

- Large enough for an employee to enter fully and perform assigned work.
- Not designed for continuous occupancy by the employee.
- Has a limited or restricted means of entry or exit.

Personal Protection Equipment (PPE) - This list is not meant to be all encompassing, but should include: safety glasses, knee protection or kneeling aid, first aid kit, fire extinguisher, insulated screwdriver set, LOTO kit, ear plugs, slip resistant black leather safety toe shoes, electrical glove kit (rubber glove and "goatskin protector"), cut resistant gloves, cut resistant sleeves, heat resistant sleeves, GFCI cord set, fall prevention kit, nitrile gloves, chemical goggles, ARC flash barrier tape, hard hat with ARC flash rated face shield, and ARC flash rated balaclava.

For models contained R-290 (propane) as a refrigerant, all instructions labeled on the unit must be closely followed. Service and repair must be performed by qualified refrigeration technicians familiar with applicable safety standards for flammable refrigerants. Technician must use appropriate personal protective precautions to avoid risk of fire or explosion.

- Service Warranty Information

- TROUBLESHOOTING GUIDE

FIND YOUR PROBLEM HERE	REMEDY
1. Condensing unit fails to start.	A. Check if cord & plug has been disconnected. B. Check control temperature setting.
2. Condensing unit operates for prolonged periods or continuously.	A. Are doors closing properly? B. Dirty condenser or filter. Clean properly. C. Evaporator coil iced. Needs to defrost.
3. Food compartment is too warm.	A. Check door(s) and gasket(s) for proper seal B. Perhaps a large quantity of warm food has recently been added or the door was kept open for a long period of time, in both cases, allow adequate time for the cabinet to recover its normal operating temperature. C. Control setting too high, readjust. D. Check that condensing coil is clean.
4. Food compartment is too cold.	A. Perhaps a large quantity of very cold or frozen food has recently been added. Allow adequate time for the cabinet to recover its normal operating temperature. B. Adjust the control to a warmer setting.
5. Condensation on the exterior surface.	A. Check door alignment and gaskets for proper seal. B. Condensation on the exterior surface of the unit is perfectly normal during periods of high humidity.
6. Compressor hums but does not start.	A. Call for service.
7. No power to unit	A. Check if cord & plug has been disconnected. B. Check power supply breaker.

6B.2 Condensate Overflow Troubleshooting

6B.2.1 Condensate Overflow

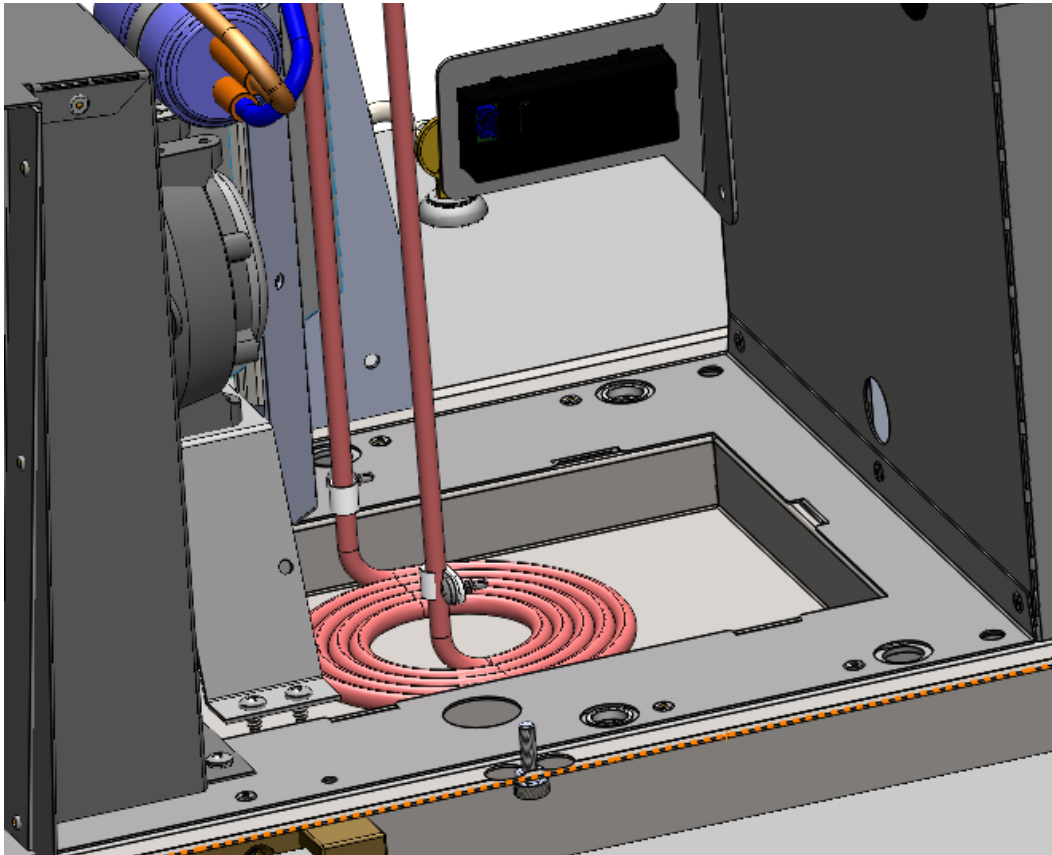

Fig. 6B.2.1 TROUBLESHOOTING CONDENSATE PAN OVERFLOW

The condensate pan generally does not overflow unless there is an excess of ambient air infiltrating the cabinet.

- Hump Cover not sealed properly (i.e. torn or missing Foam Tape).
- The door is not sealed properly.
- Door not self-closing (see door section).
- Putty not fully sealing refrigeration lines penetrating evaporator compartment.
- On refrigerators with electric defrost- shorting the time between defrost may help to reduce the amount of water (see control section).

6B.3 Leak Checking System

A number of means for leak detection may be considered:

- Bubble test
- Holding pressure test (refer to serial tag for maximum system pressure)
- Electronic leak detector

Never use any dyes or other contaminants when working with Traulsen refrigeration systems.

For R-290 (propane) systems, make sure the electronic leak detector being used is designed to detect R-290 (propane). A combustible gas monitor may also be used to indicate the presence of a leak.

6B.4 Accessing the Refrigeration System

Piercing valves can be used to access the refrigeration system. Access ports should be temporarily placed on the process tube (suction and/or liquid line) as close to the end of the process tube as possible.

Do **NOT** leave piercing valves on this system. If you cannot finish the repair you will need to use Lock/Out-Tag/Out procedures.

- Pinch line off just before the temporary access port three times using a crimper tool.
- Verify that there are no leaks.
- Remove the piercing valve/temporary access port.
- Cut off the copper tubing between the location of the temporary access port removed in step 3 and the crimps made in step 1.
- Braze open end shut.
- Leak check the system.



6B.5 Refrigerant Recovery

For refrigeration systems using R-290 (propane), the U.S. EPA has allowed venting to the atmosphere due to its low environmental impact. Use the following process. This process requires the use of a combustible gas monitor.

1. If the refrigeration system is located in a confined area, consider using the refrigerant recovery process noted above. The R-290 (propane) can then be vented later in a safe location.
2. Venting must not be to a public area with people present that are unaware of the procedure.
3. The technician responsible for venting R-290 (propane) must make all persons in the immediate area aware a flammable gas is being released to the atmosphere.
4. Ensure there are no ignition sources within 10 ft. of the area you are venting R-290 (propane).
5. Ensure that all local legislation addressing safety of hazardous or flammable substances are satisfied.
6. Like most other refrigerants, R-290 (propane) is heavier than air. Ensure you are venting it into a low-lying area.

6B.6 Repair of Leaks

It is of utmost importance to properly repair refrigerant leaks as soon as they are discovered. If they cannot be repaired immediately, the refrigerant charge should be removed from the system until the point at which the leak can be repaired. A number of considerations are relevant when attempting to repair a leak:

- Repair the leak properly - this means removing the refrigerant, examining the leak source, determining the reason for the leak and carrying out the proper course of action.
- Before repairing the leak, ensure that the refrigerant has been removed and the system flushed with nitrogen if brazing is to take place.
- Always run low pressure nitrogen through the system when brazing as this reduces the risk of oxidation. For R-290 (Propane) systems, this also reduces the risk of combustible gas ignition.
- It is **absolutely not acceptable** to leave line tap valves or piercing valves attached to the system.

6B.7 System Evacuation

After the system has been sealed and leak checked, it is necessary to evacuate it in order to remove air, moisture, and unwanted residual refrigerant.

- With R-290 (propane) systems, first purge the system with nitrogen. This will prevent flammable mixtures from occurring.
- When connecting the hoses between the system, gauge manifolds, and vacuum pump, ensure that the connections are secure. For R-290 (propane) systems, ensure that there are no potential ignition sources nearby.
- For R-290 (propane) systems, ensure that the pump discharge is in an area free of potential ignition sources.
- Ensure that a micron gauge is used since conventional manifold gauges may not provide proper readings.
- The system should be evacuated to the desired pressure (typically 250 microns or less) and then left to stand for 15 minutes to ensure that the entire refrigerant charge has been removed from the oil and any residual moisture has been evaporated from the system.
- Ensure that the vacuum pump is of good quality and of appropriate capacity for the system, and the oil level is correct.

6B.8 Charging the System

After the proper evacuation of the system, the following process should be followed:

1. Process Tube needs to be extended.
 - Remove the crimped tubing and piercing or saddle valve from the process tube.
 - Extend the process tube a minimum of 12".
 - Crimp and braze the process tube extension.
 - Install piercing or saddle valve just after the last crimp.
2. Evacuate the system following the SYSTEM EVACUATION section in this document.
3. Charge the system.
 - **DO NOT OVERCHARGE THE SYSTEM.** You must weigh in the exact charge.
 - Prior to charging, ensure the system has been leak checked.
 - Hoses or lines should be as short as possible to minimize the amount of refrigerant contained in them.
 - Evacuate the hoses and manifold prior to charging to avoid contamination of the refrigerant.
 - Upon completion of charging, a further leak check must be carried out prior to leaving the site.
 - After charging, carefully disconnect the hoses, attempting to minimize the release of refrigerant.
 - After charging, all access ports must be removed following the **REMOVE ACCESS PORTS** section in this document.

6B.9 Remove Access Ports

Do **NOT** leave piercing valves on this system. If you cannot finish the repair you will need to use Lock/Out-Tag/Out procedures.

1. Pinch line off just before the temporary access port three times using a crimper tool.
2. Verify that there are no leaks.
3. Remove the piercing valve/temporary access port.
4. Cut off the copper tubing between the location of the temporary access port removed in step 3 and the crimps made in step 1.
5. Braze open end shut.
6. Leak check the system following the **LEAK CHECKING SYSTEM** section in this document.

6B.10 Compressor Troubleshooting

6B.10.1 Terminology:

OEM - Original Equipment Manufacturer, refers to the manufacturer of a piece of equipment or component.

RLA - Rated Load Amps, the OEM test conditions amperage rating (does not necessarily indicate the normal running amperage as conditions and applications can vary from OEM test conditions).

LRA - Locked Rotor Amps, the OEM test condition lock rotor amperage rating indicating the expected amperage at which a motor does not turn when power is applied.

Microfarad - This is a unit of measure for capacitance; the symbol for **Microfarad** is μF .

Current - The flow of electrons in an electrical circuit measured in Amps with an Amp Meter.

Resistance - The opposition to the flow of electrical current measured in Ohms with an Ohm Meter; the symbol for Ohms is Ω .

Back EMF - The voltage generated by the start winding once the compressor runs which is higher than line voltage.

Pick-up Voltage - The back EMF value at which the normally closed contacts of a potential relay open.

First verify that the Call for Cooling LED on this display is illuminated. See Control Section.

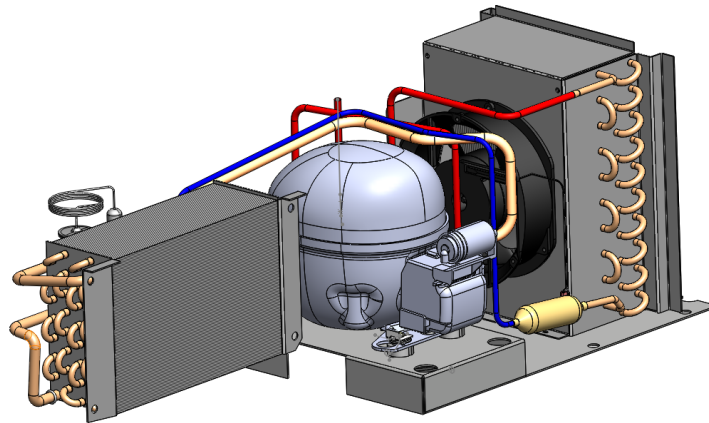

Fig. 6B.10.1b R-290 COMPRESSOR

6B.10.2 Accessing the Compressor

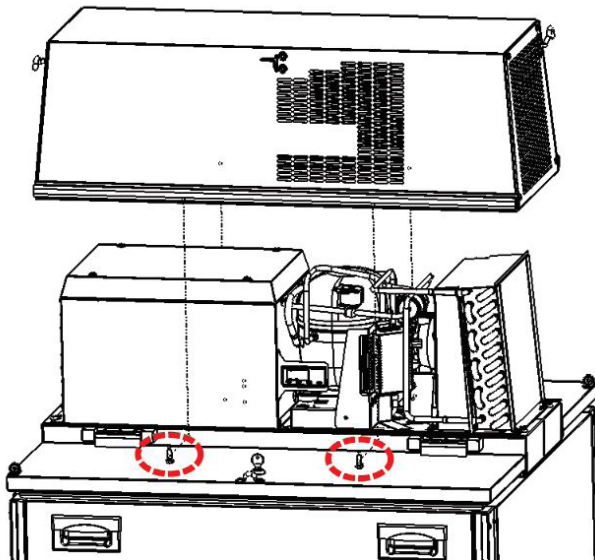

Fig. 6.10.2 REMOVE (4) SCREWS

6B.10.3 Compressor Not Running

If the condenser fan motor is running but not the compressor, the compressor may be overheated. Carefully place your hand on the dome of the compressor. If the compressor is very hot, the external overload protector may be open. Disconnect power to the unit and give the compressor ample time to cool.

6B.10.4 Testing the Windings of the Compressor

After the compressor has been sufficiently cooled, remove all the start components from the compressor. Now use an Ohms Meter to measure the resistance of the windings. Be careful when measuring resistance to make a good connection to each terminal with your meter lead. Take several measurements to ensure you are consistently getting the same values. If the resistance values are consistent but do not match the values given below, replace the compressor with OEM replacement.

6B.10.5 Resistance and AMP Values of Milk Cooler Compressors

Compressor Information			Resistance		Current	
Traulsen Part Number	Embraco Model	Copeland Model	Start Winding	Run Winding	RLA	LRA
R450 134A MODELS						
321-60203-20	NEU6160Z	ARE25C5E-CAA	7.00 Ω	1.86 Ω	4.30	25.0
321-60205-10	NEK6187Z	ARE34C4E-IAA	6.10 Ω	0.96 Ω	4.60	37.00
R290 MODELS						
321-60297-00	EMX4121U	RFT26C1E-CAA	6.76 Ω	2.17 Ω	3.70	21.30
321-60310-00	EMX4115U	RRT64C1E-CAA	6.78 Ω	4.21 Ω	4.30	21.3

Table 6B.10.5 RESISTANCE AND AMP VALUES

6B.10.6 Troubleshooting External Overload Protector

If the windings of the compressor match the values given above, the overload can be tested with an Ohms Meter for continuity. A closed switch should have continuity indicative of a complete circuit. If the external overload will not close after cooling, replace the overload protector. If the compressor starts and runs while the current is at or below the RLA, but the overload still opens, replace the external overload protector with OEM replacement.

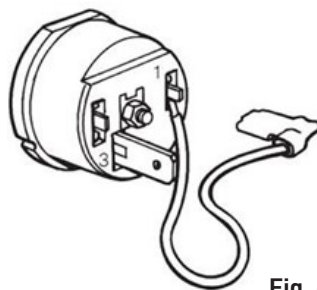

Fig. 6B.10.6 OVERLOAD

6B.10.7 Measuring for Excessing Voltage Drop

Now that the compressor has cooled down, measure the voltage supplied to the cabinet while the compressor is trying to start. If the voltage drops below 104 volts, you may have a problem with the power supply, try a different circuit.

6B.10.8 Troubleshooting Potential Relay

Disconnect the power supply, remove wires and measure for continuity between pins 1 & 2 (normally closed contacts) of Potential Relay. If continuity is not detected replace the Potential Relay.

Clamp amp probe onto blue wire connected to pin number 1 of the Potential Relay. Apply power and measure the current. If the current does not drop out after the compressor starts, then the contacts between pins 1 & 2 are stuck in the closed position. In this case, the Potential Relay must be replaced.

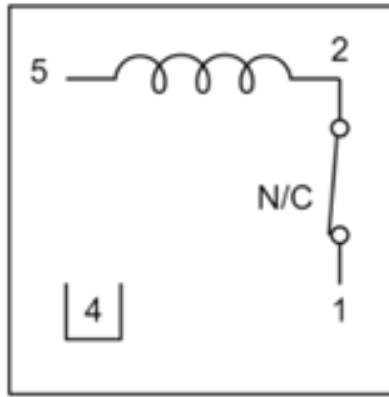

Fig. 6B.10.8 POTENTIAL RELAY SCHEMATIC

6B.10.9 Troubleshooting Start Capacitor (BLACK PLASTIC CASING)

If the voltage measures 115 volts +/- 10% but the compressor doesn't start, measure the current with your amp meter at the common terminal of the compressor. If the current spikes very high but the compressor doesn't start, disconnect the power so that you can remove all the start components for testing. Start capacitors can be tested with a microfarad tester. For the most accurate measurement, remove the resistor from the start capacitor. **The start capacitor should never be used without the resistor as this will damage the start relay.** If microfarads measured do not match the values in the table below, replace the start capacitor.

6B.10.10 Troubleshooting Run Capacitor (METAL CASING)

If the compressor starts and runs with an amp draw higher than the RLA and the compressor is a capacitance run compressor (which means it requires a run capacitor), disconnect the power so that you can remove the run capacitor from the circuit for testing with a microfarad tester. Connect the microfarad tester across both terminals of the run capacitor. If the microfarads measured do not match the specs given, replace the run capacitor.

Note: If the run capacitor is swollen or leaking fluid, it must be replaced.

Compressor		Start Components				
Model	Traulsen Part Number	Start Capacitor PN	Run Capacitor PN	Relay	Overload	Start Cap
R134/R450	321-60203-20	334-60411-28	334-60412-07	334-60409-15	334-60417-35	189-227mfd
R134/R450	321-60205-10	334-60411-27	N/a	334-60416-23	334-60417-16	189-227mfd
R290	321-60310-00		N/a			
R290	321-60297-00		N/a			

TABLE 6B.10.10 MILK COOLER START COMPONENT PART NUMBERS

6B.10.11 Locked Up Compressor

After all start components have been properly tested and determined to be good and the proper voltage has been verified, the compressor does not start while the current spikes up to the LRA, this could be indicative of an internal mechanical problem within the compressor. If so, replace the compressor with OEM replacement.

6B.10.12 Current Climbs above RLA

See section on Troubleshooting Run Capacitor first. If the amps start out at RLA but climb higher until the external overload protector opens, this could be an indication of poor air circulation through the condenser coil resulting in higher head pressure. The solution could be as simple as cleaning the condenser coil or a problem with the condenser fan motor, such as tight bearings or a fan blade that has been installed backwards. If none of the above, this could also be a symptom of an internal mechanical problem within the compressor. If so, replace the compressor with OEM replacement.

Note: When a system is overcharged, the compressor current may be above RLA.

6B.10.13 Replacing the Compressor

If you have taken all the proper steps outlined above to troubleshoot the compressor, and therefore have determined the compressor has failed, **be sure to replace the liquid line filter drier along with the compressor.** Traulsen recommends that you use a nitrogen flow regulator to purge with low pressure nitrogen as you braze all connections. After you have brazed all connections and have checked thoroughly for leaks, change the oil in your vacuum pump before connecting to system with a micron gauge. Pull a deep vacuum of 200 microns to remove moisture from the system.

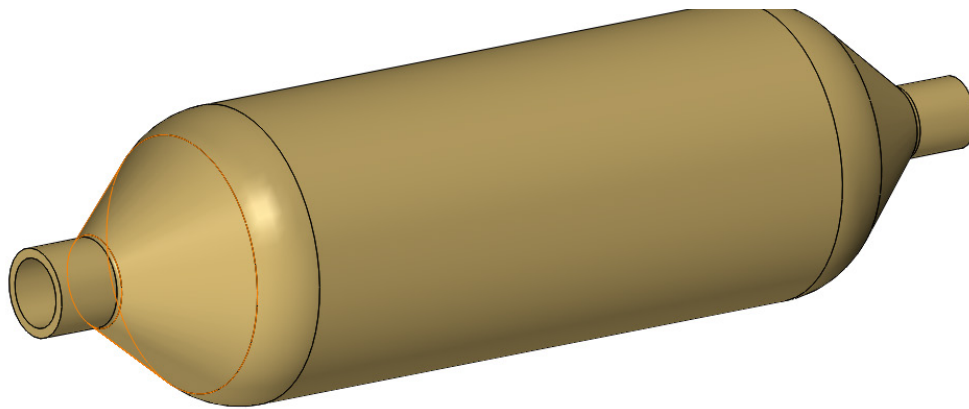

Fig. 6B.10.13b R-290 FILTER DRIER
P/N: [325-60277-00](#)

6B.10.14 Milk Cooler Temperature Checklist

This is to inform the field of basic operational check points related to temperature maintenance concerns to understand prior to troubleshooting the refrigeration system function.

Troubleshooting checklist

What is the walk-in cooler/milk storage cooler temp?



33F (1C) 36F (2C) 39F (4C) 41F (5C)

What is the temperature of the milk before it is put into the milk cooler for serving ?



33F (1C) 36F (2C) 39F (4C) 41F (5C)

How long is the serving period?



[Recommend Doors Closed for at Least 15min for Every 2 hours of Operation.]

What is the ambient air temperature around the unit?

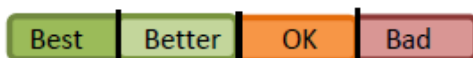

70F (21C) 80F (26C) 90F (32C) 100F (37C)

Are there any significant sources of heat around the unit?

Is there HVAC ventilation directly above the unit or other sources of forced air circulation that may be disrupting the air flow of the milk cooler?

With door closed how fast does unit pull down to temperature?

[Depending on the Milk Cooler footprint & loading, it will typically take 15-20 min for the unit to pull down and cycle.]

Is the milk rotated? If so how often?

[Recommend product is rotated every 2 hours.]

6B.10.15 Compressor Wiring Schematics

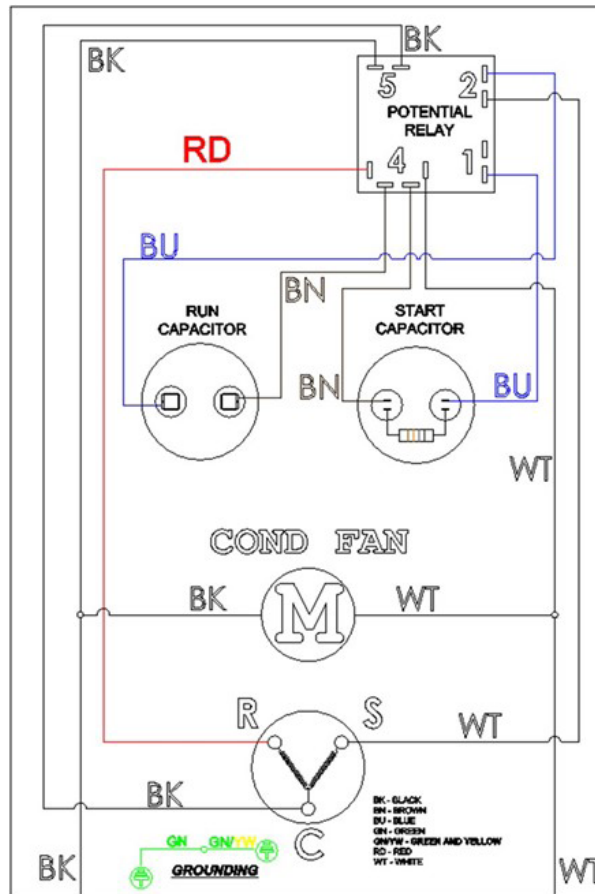

Fig. 6B.10.15a CAPACITOR RUN/
CAPACITOR START COMPRESSORS

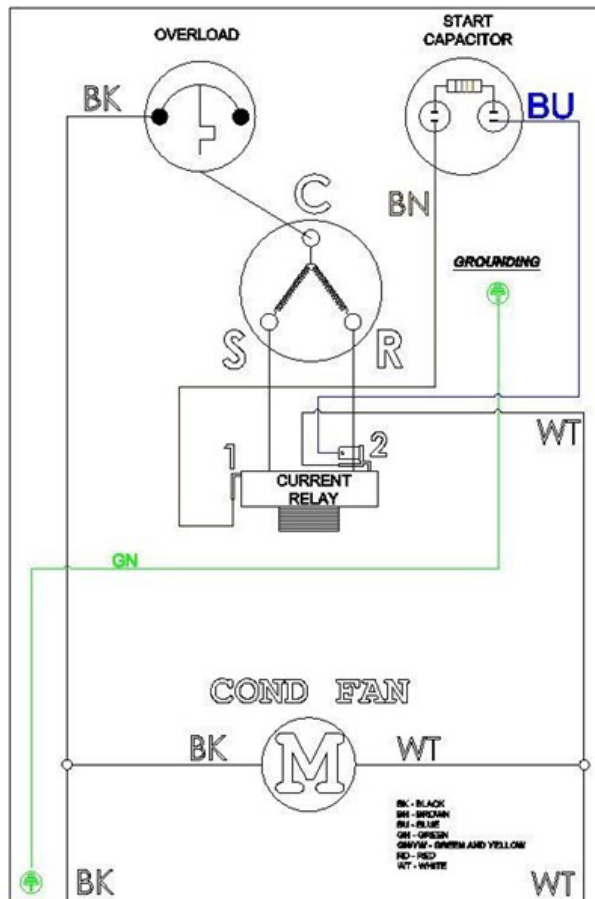
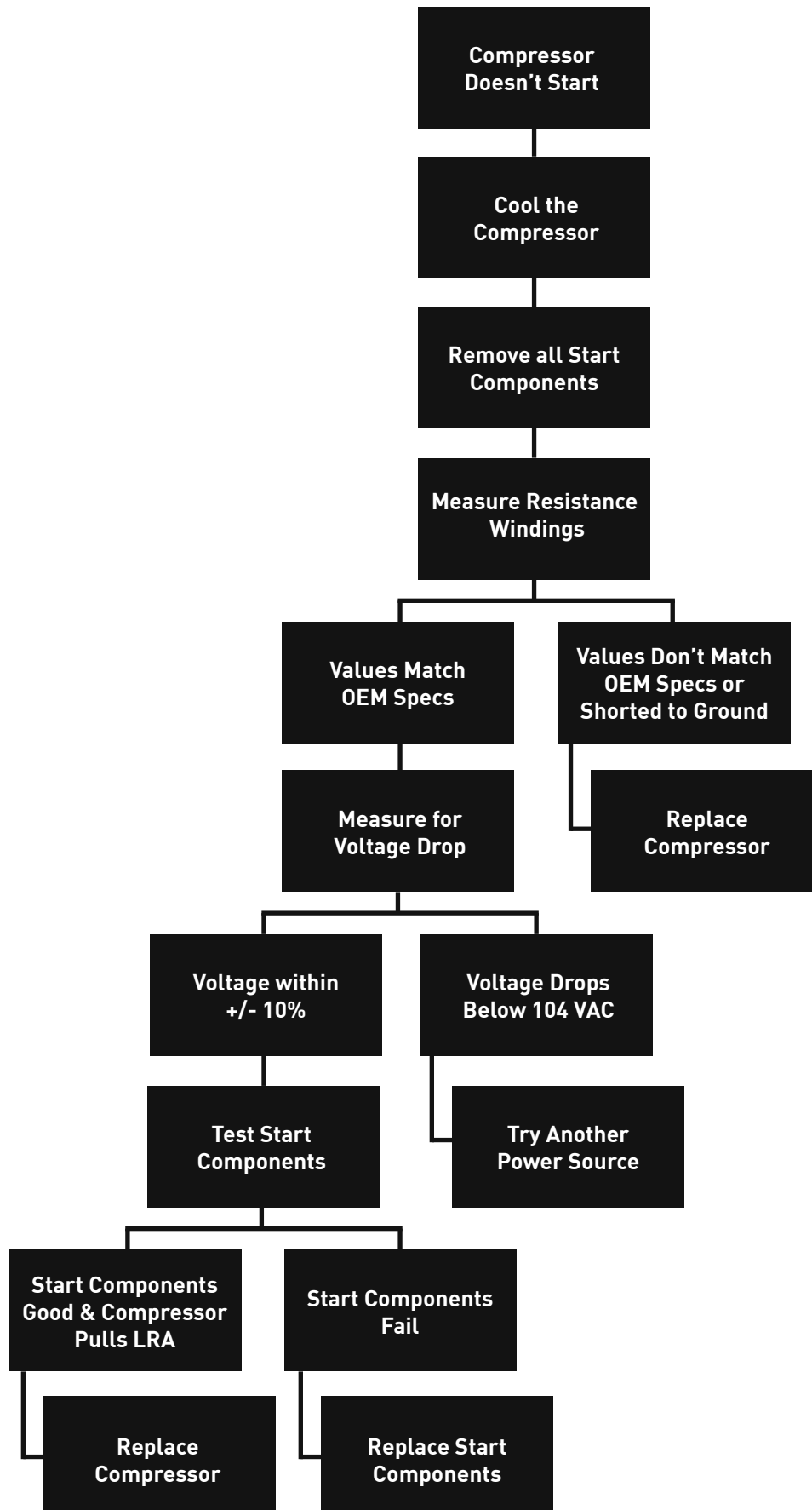
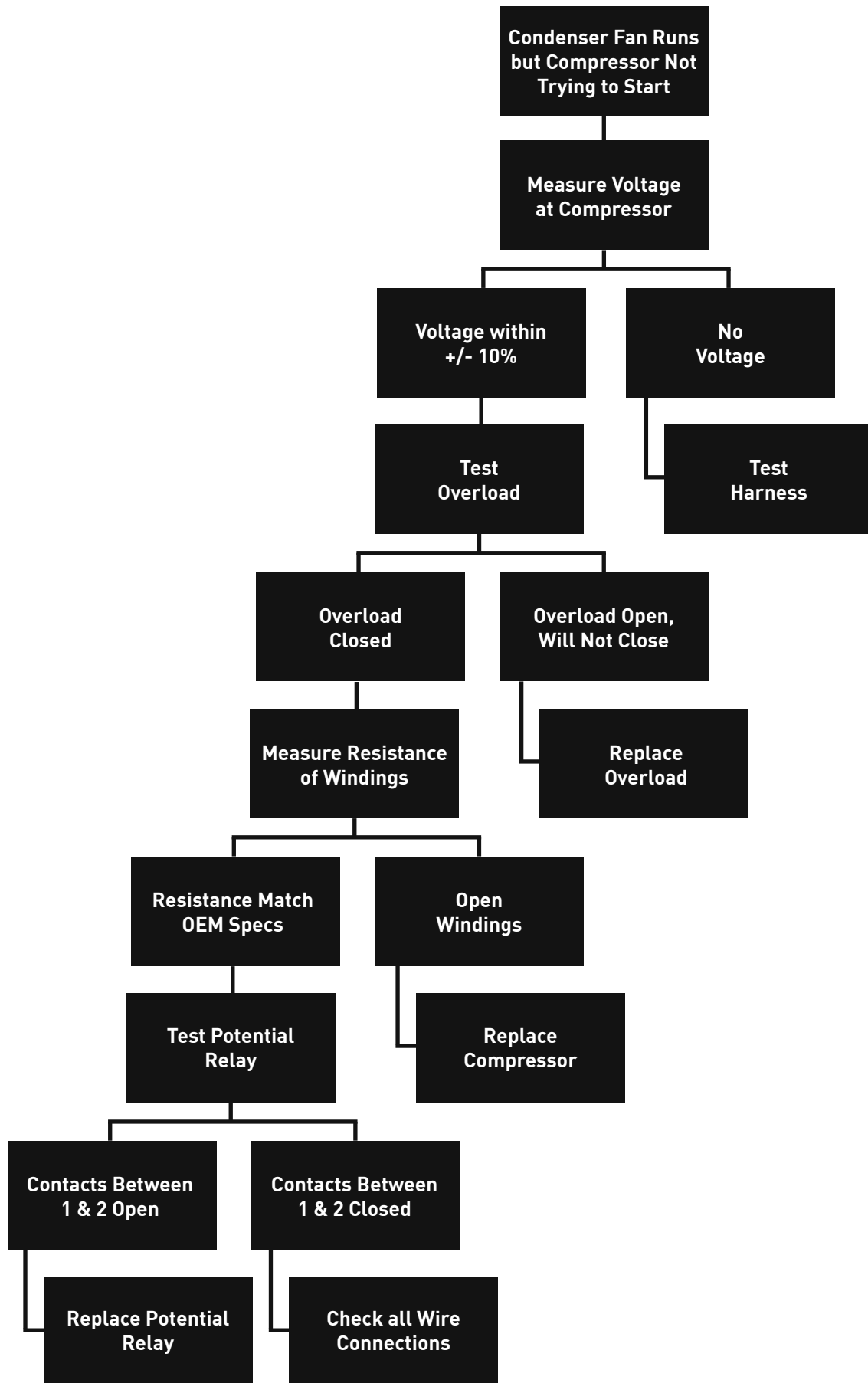

Fig. 6B.10.15b INDUCTION RUN
CAPACITOR START COMPRESSORS

6B.10.16 Compressor Short Cycles on Overload Protection



6B.10.17 Compressor Not Trying to Start



6B.11 CF10B Electric Inverter

6B.11.1 General Product Specifications

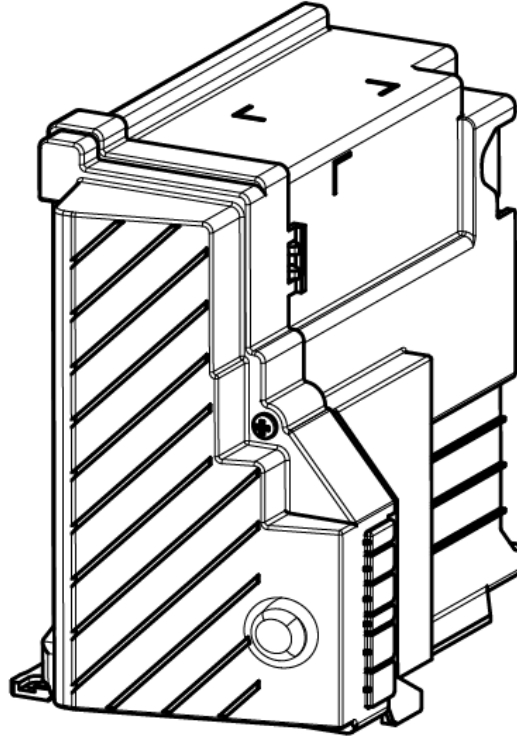

CF10B Embraco Electric Inverter

General Specifications	
Input rated voltage range ⁱ	120 V or 240 V
Input operating voltage range ^{ii, iii, iv}	70 V-140 V or 160 V-264 V
Maximum input voltage ^{v, vi}	176 V or 300 V
Input frequency range	50-60 Hz
Input rated current	15.5 A
Input rated power	1000 W
Control mode	Frequency, Drop-in and Serial
Fan driver maximum current	1 A
Operating humidity	← 85%
Environmental humidity ^{vii}	10% to 85%
Operating ambient temperature ^{viii}	-20° C to 55° C
Storage temperature	-40° C to 85° C
Air forced ventilation (min) ^{ix}	2 m/s

6B.11.2 Technical Specifications



- Do not connect the CF10B Inverter to a power supply above declared Maximum voltage.



- This inverter is for use only with the Embraco VCC compressors.
- Operating the product at voltages out of declared Input operating voltage range may reduce its reliability and significantly impair product performance.
- Make sure to apply the proper Inverter - VCC match. The use of incorrect Inverter - VCC may degrade product overall performance.
- In order to avoid loss of performance, make sure to operate the inverter inside the temperature range of -20 °C to 55 °C.
- Ambient operation temperature above 55 °C or inappropriate positioning of the inverter related to forced ventilation air flow may activate inverter thermal protection.

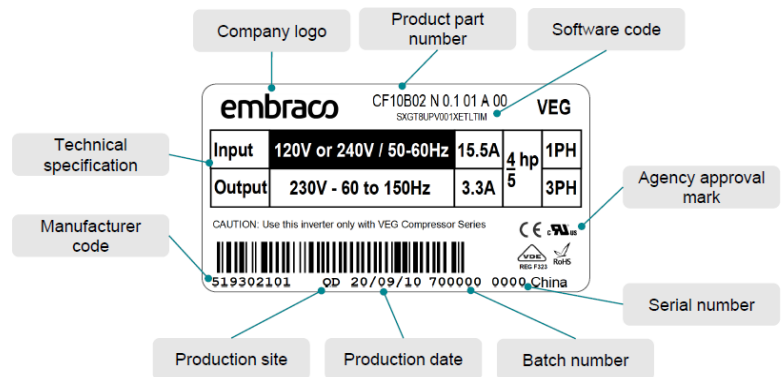

Label Identification

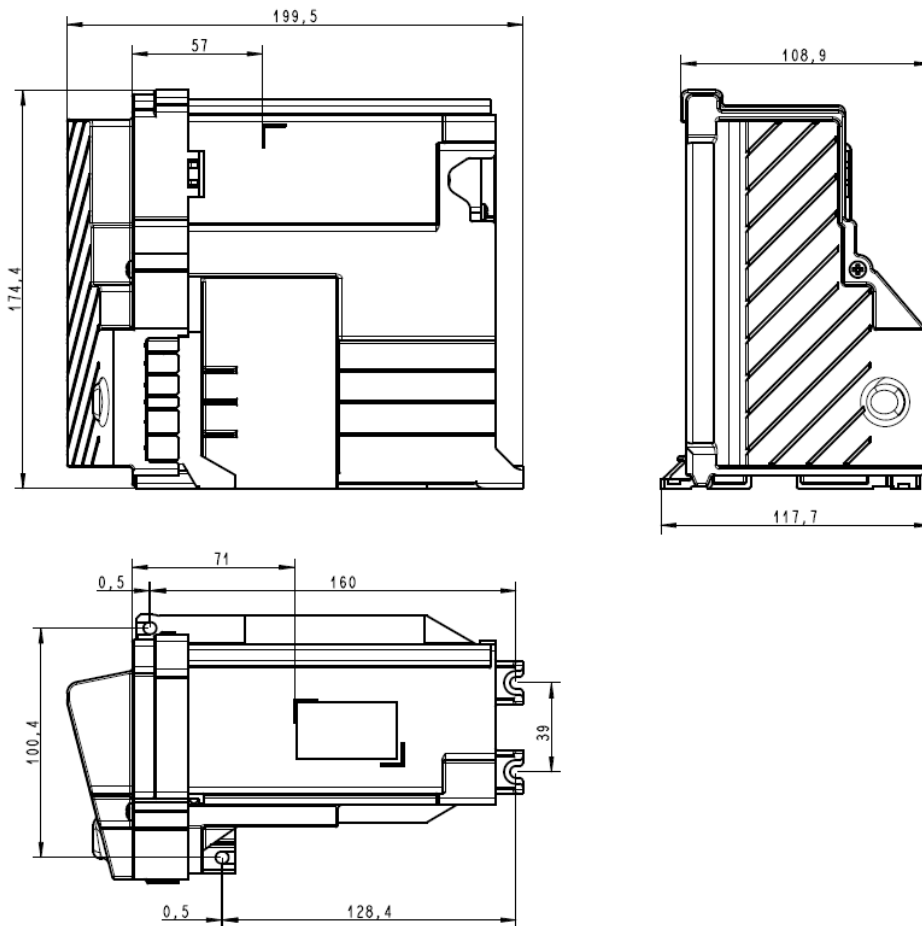

**CF10B Product Dimensions
Stand Alone Dimensions (mm)**

6B.11.3 Connectors

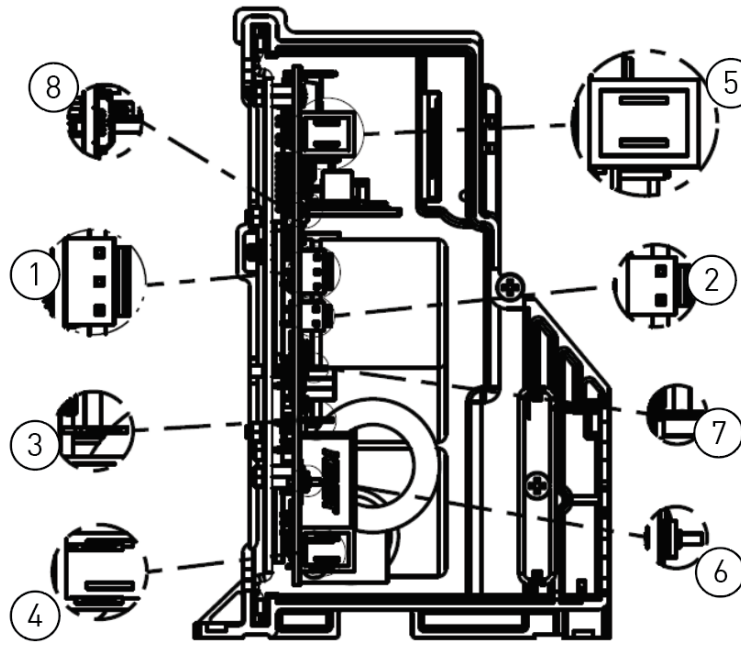

*Mates with 1/4" fasten receptacle. Fan connector assemble is optional.

Connector Diagram

Connectors Part Numbers			
Indicator	Description	Part Number	Insulation
1	Serial Communication	S3P-VH (LF) (SN)	Reinforced
2	Frequency input	S2P-VH (LF) (SN)	Reinforced
3	Drop in	1217754-1	Non-insulated
4	AC input (L+N)	1217754-1	Non-insulated
5	AC Fan*	MSLO 9402 - 002 - 00A - 960 - 000 - 00	Non-insulated
6	EMI Earth	Cable supplied by embraco	
7	Defrost input	1217754-1	Non-insulated
8	"You Control" input	Micro-USB B	Non-insulated



- The 'You Control' customization input (micro USB port) does not have electrical insulation. Use the provided communication modules defined by Embraco to guarantee electrical insulation. Check Subsection 4.2.2 for information regarding the indicated communication modules and product customization.

NOTICE

- CF10B inverter series standard configuration is approved to be used only in built in appliances, with not accessible machine compartment. If the intended appliance is an open machine compartment type, please contact Embraco's technical support to ensure the proper configuration of your product.

6B.11.4 Connection

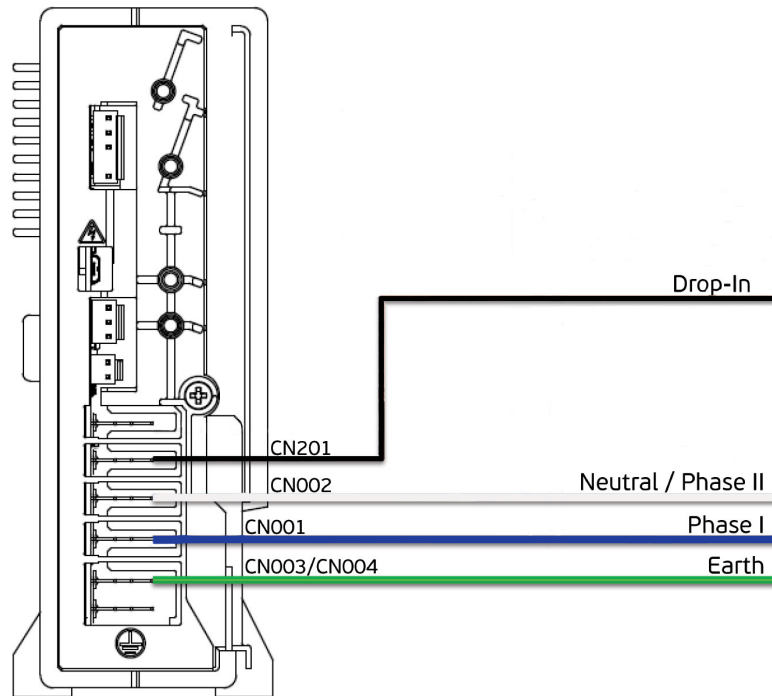

Energized Contact Drop-in Connection

6B.11.5 LED Indication

The LED diagnostics function helps services technicians to diagnose possible fault components by blinking a LED inside the box in different patterns. Basically, it indicates if there is a problem with Compressor, CF10B Inverter or Thermostat. The table below describes the failure modes.

Led Status	Period	Color	Description
1 Flash	30 Seconds	Green	Normal Operation
2 Flashes	5 Seconds	Green	Communication Problem
3 Flashes	5 Seconds	Red	Inverter Problem
4 Flashes	5 Seconds	Red	Compressor Problem
No Flashes	-	-	No Input Power / Damaged Inverter

6B.11.6 Troubleshooting

The following tables shows some possible problems and the best action to deal with them.

Compressor Does Not Start	
Problem	Action
Compressor disconnected from the inverter.	Verify compressor cable connection
No AC power supply; or wrong voltage/terminals connected.	Verify AC input cable connection and measure AC input voltage.
No control signal input or bad connection.	Verify control input cable connection and measure the signal from the thermostat.
Blown fuse (due to previous major failure).	Return the unit to manufacturer, replacing it by new one.
Open compressor motor winding.	Measure winding for open circuit between all pair of pins on the hermetic terminal. If any winding is open, return compressor to manufacturer.
Compressor with locked rotor (due to mechanical damage).	Replace compressor by new one and test for confirmation. Return damaged unit to manufacturer.
Dropped, damaged, burnt inverter.	Replace by new one and test for confirmation. Return damaged unit to manufacturer.
Inverter on waiting time after failed start.	Wait the necessary time or reset the inverter disconnecting it from the AC power supply. The reset time is about 50s.
Demagnetized rotor (only if compressor was previously connected directly to the AC power supply).	Replace compressor by a new one and test for confirmation. Return damaged unit to manufacturer.
Unequaled pressures between discharge and suction pressures in the refrigerating system.	Allow the Inverter to equalize pressure between suction and discharge sides.
Low input voltage supplied to the inverter.	Measure AC voltage to confirm.

6B.11.7 Diagnostics

Compressor does not run at the selected speed	
Problem	Action
High compression load, with compressor being subjected to a stall condition.	Review system design, refrigerant gas load or compressor capacity is not suitable for the application. If system is appropriately designed, speed will reach set value when load condition is stabilized.
Compressor always on pull down cycle for Drop-In Mode.	In Drop-In mode, check if the inverter AC input is connected to thermostat output. Inverter AC input should be directly connected to AC power supply (see Drop-In mode schematic).
No or incorrect control signal.	Check if the appropriate control signal is being correctly applied to the Control Input Connection.

6B.12 Evaporator Fan Troubleshooting

6B.12.1 Steps for Troubleshooting Milk Cooler Evaporator Fan

1. First verify fan icon is illuminated on the display indicating a call for the evaporator fan. Remember- the fan will shut off when door is open, so if you open door to physically check if fan is running you will need to disconnect white door switch connector from control board.



Fig. 6B.12.1a EVAPORATOR FAN ICON ON DISPLAY

2. Next use an amp meter to prove the evaporator fan motor is running.
3. If fan motor is not running use voltage meter to measure the voltage at fan motor if measurement within +/- 10% of rated voltage replace the fan motor.

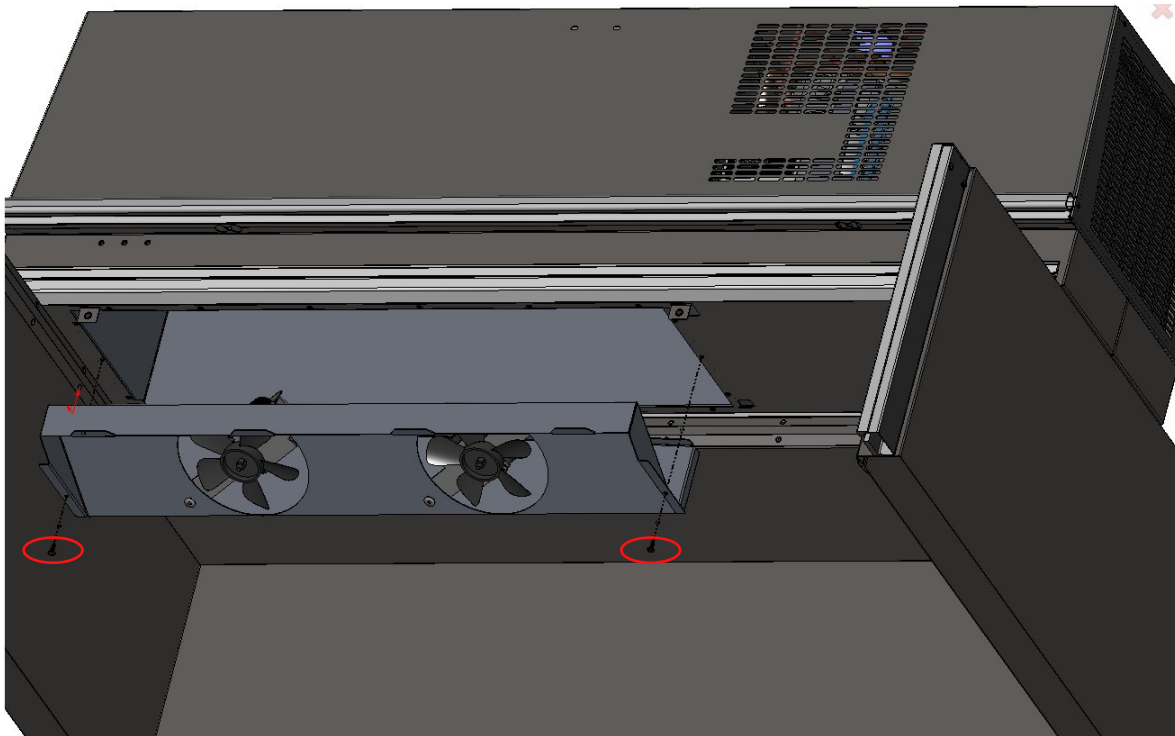

Fig. 6B.12.1b DUCT REMOVAL

Fig. 6B.12.1c EVAPORATOR FAN ASSEMBLY REMOVAL

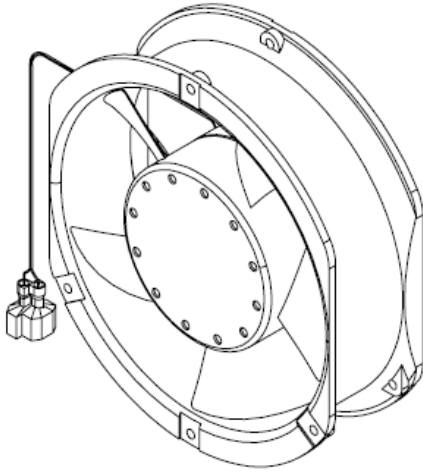
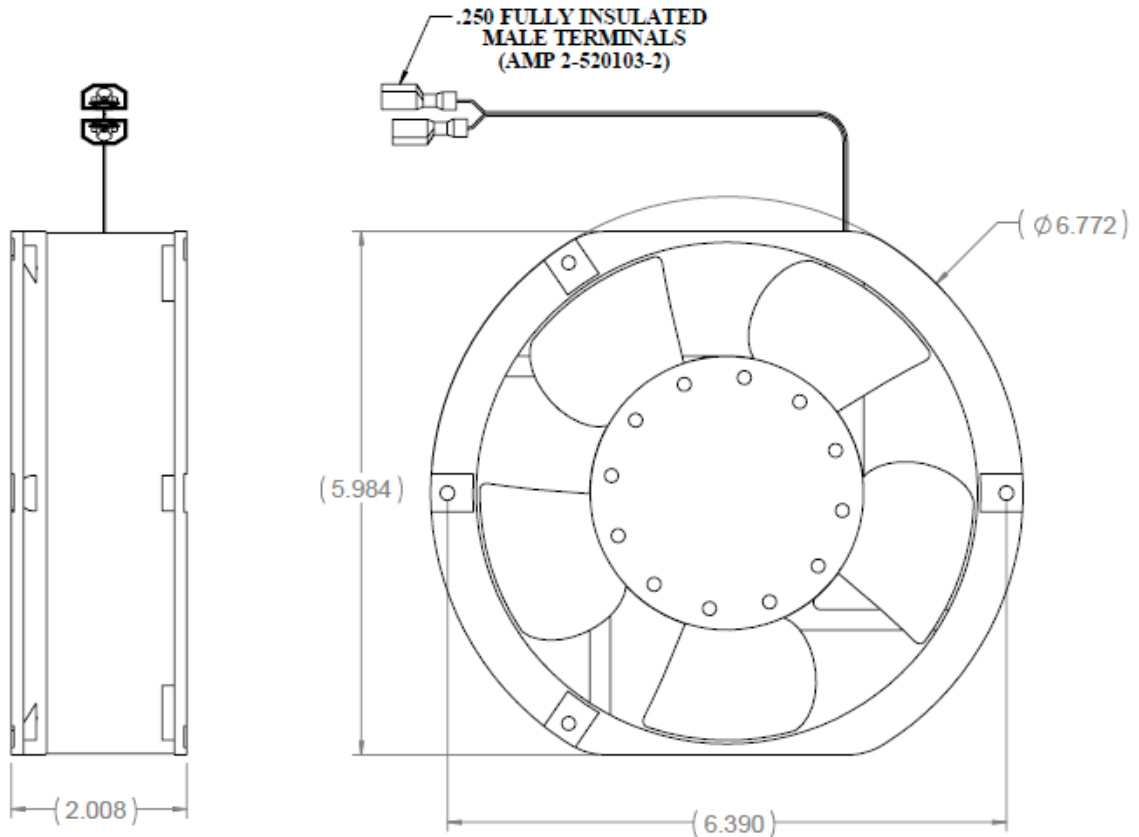

Fig. 6B.12.1d AC- VARIABLE FREQUENCY MOTOR (CURRENT) R290
TRAUlsen P/N 338-60063-00
PN: EC17251B00H-01

338-60063-00 (R290)	
DESCRIPTION/ SPECIFICATION	MANUFACTURER
Part Number	338-60063-00
Amps	0.45 A
Voltage	85-265 VAC
Frequency	50/60 Hz
Speed	3,200 RPM
Rotation	CCW, FROM LABEL SIDE

Table 6B.12.1d AC- VARIABLE FREQUENCY MOTOR SPECS



EVAPORATOR FAN BLADE SPECIFICATIONS (C-FRAME)	
COLOR	BLACK
BALANCE	0.008 INCH-OZ Max
AXIAL RUNOUT	0.056 INCH I.R. Max
RADIAL RUNOUT	0.056 INCH I.R. Max
MATERIAL	UL94-HB UNFILLED POLYPROPYLENE PP 828,3208, OR APPV'D EQUIV
INSERTION FORCE	15-40 LBF
SHAFT DIMENSION	0.181 ROUND

Table 6B.12.1e EVAPORATOR FAN BLADE SPECS

Shaded Pole Motor Design
(C-Frame)

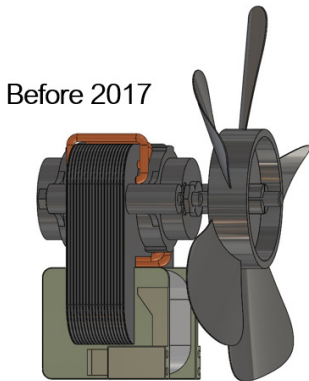

Fig. 6B.12.1e SHADED POLE MOTOR
(PRE 2017) R450
TRAULSEN P/N 338-60054-00

PN: 338-60054-00 (R450)	
DESCRIPTION/ SPECIFICATION	MANUFACTURER
	N/A
PART NUMBER	EXRi50-154F-B-2400-M01
OUTPUT	8 WATTS
AMPS	0.07 A
VOLTAGE	120/230 VAC
FREQUENCY	50/60 Hz
SPEED	2,400 RPM
ROTATION	CW
AIR FLOW	168 CFM

EC-Motor (Electronically Commutated)

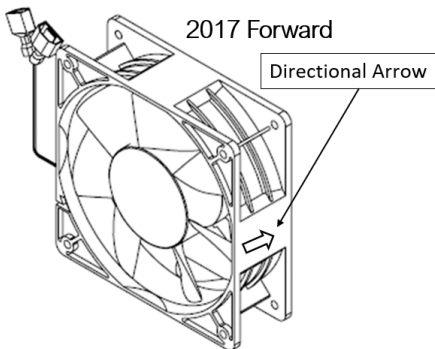

Fig. 6B.12.1f ECM FAN MOTOR CW FROM LEAD END
(2017 - 2024) R450
TRAULSEN P/N 338-60062-00

338-60062-00 (R290)	
DESCRIPTION/ SPECIFICATION	MANUFACTURER
	N/A
PART NUMBER	EC12038B00HL-01
OUTPUT	9.5 W
AMPS	0.07 A
VOLTAGE	110/240 VAC
FREQUENCY	50/60 Hz
SPEED	3,500 RPM
ROTATION	CW
AIR FLOW	126 CFM

6B.13 Condenser Fan Troubleshooting

6B.13.1 Troubleshooting the Condenser Fan Motor on Milk Cooler

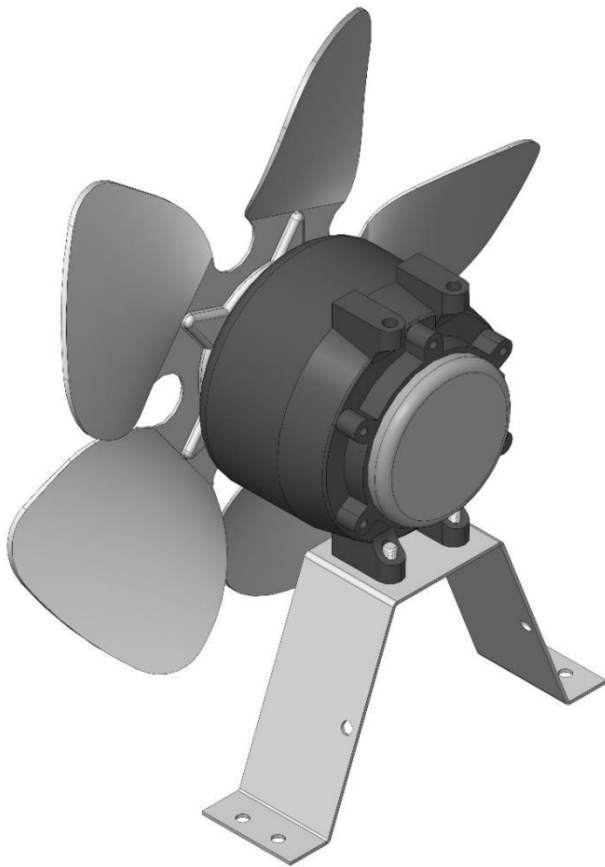

Fig. 6B.13.1a CFM ASSEMBLY VIEW



Fig. 6B.13.1b LED DISPLAY

First verify that the Call for Cooling LED on the display is illuminated. If the compressor is running but not the condenser fan motor, you should measure voltage at the condenser fan motor. If you measure +/- 10% of rated voltage but the motor doesn't run, replace the fan motor.

6B.13.2 Motor Bearing Failure

Problems with motor bearings can be easily overlooked- as the motor will run while the cabinet drops in temperature until the motor overheats. Once the motor overheats it will shut off on the internal overload until the motor cools sufficiently. If the condenser fan motor is making a loud grinding noise, leaking oil from the bearings, and pulling excessive current to the motor, the bearings have failed. If the condenser fan motor exhibits these motor bearing failure symptoms, replace the fan motor.

TRAULSEN CAST IRON 9 WATT CONDENSER MOTOR P/N: [338-60049-00](#)

DESCRIPTION/ SPECIFICATION	MANUFACTURER	
	MORRILL MOTORS, INC.	ELECTRIC MOTORS
MODEL	SP-B9HUS1	SPFBE91T
PART NUMBER	12365	E128044
OUTPUT	9 WATT	9 WATT
AMPS	0.53 A	0.60 A
VOLTAGE	115 VAC	115 VAC
FREQUENCY	50/60 Hz	60 Hz
SPEED	1,550 RPM	1,550 RPM
ROTATION	CW	CW

Table 6B.13.2 CONDENSER FAN MOTOR

6B.13.3 Access and Removal of Condenser Fan Motor

EXAMPLE - PRE 2024 R450A MODELS

STEP 1:

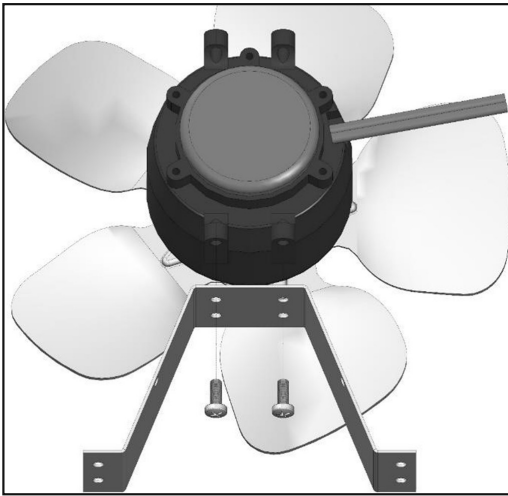

Fig. 6B.13.3.1a REMOVE FAN MOUNTING BOLTS

STEP 2:

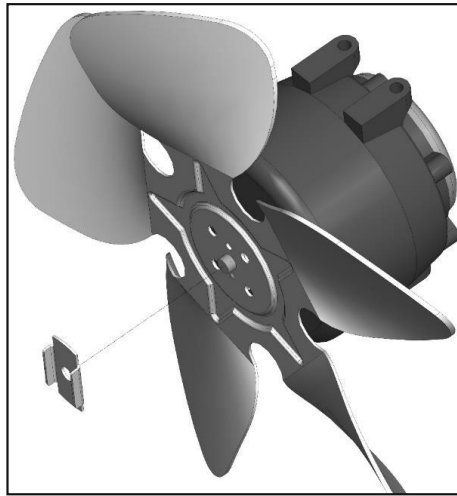

Fig. 6B.13.3.1b REMOVE SPEED NUT

STEP 3:

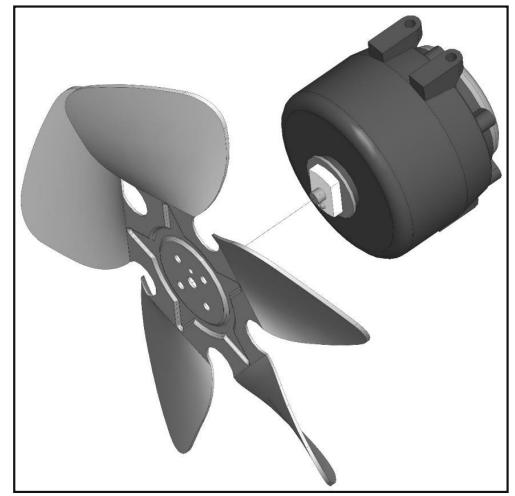

Fig. 6B.13.3.1c REMOVE FAN BLADE

DESCRIPTION	TRAULSEN PART NUMBER
9-WATT 115 VOLT CW SHADED POLE	338-60049-00
22 WATT 100-200/220-240 VAC CCW AC VARIABLE FREQUENCY MOTOR	CURRENT 2024 R290 MODELS 338-60063-00

Table 6B.13.3 CONDENSER FAN MOTOR TRAUlsen P/N

When replacing the motor, be sure to note the direction of air flow as well as the position of the fan blade. The motor is designed to pull air through the condenser coil. The fan blade should be installed with the concave toward the motor using speed nut included with the motor. The vibration washer, which is supplied with the motor, must be installed between the motor and fan blade. Torque speed nut to 10 IN-LB.

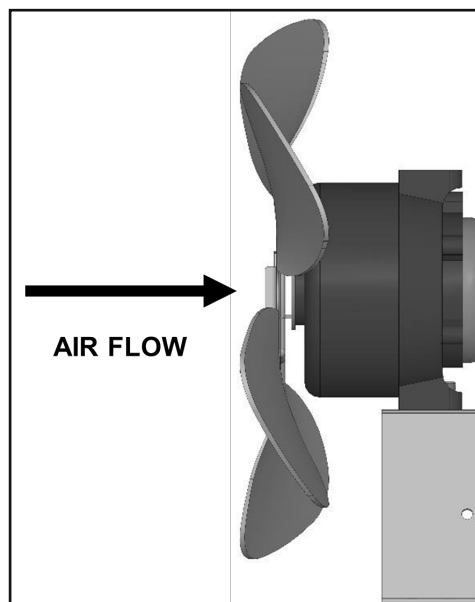

Fig. 6B.13.3d FAN BLADE ORIENTATION

Refer to the figure above to confirm the fan blade orientation when mounted on the bracket.

6B.14 Troubleshooting Thermostatic Expansion Valve

All Traulsen Milk Cooler refrigerators are equipped with Thermostatic Expansion Valve (TXV). The TXV is a type of metering device that meters liquid refrigerant into the evaporator coil. A TXV is superior to a capillary tube metering device, as it can respond to load changes. The TXV is designed to control the superheat value of the refrigerant leaving the evaporator coil. This control of superheat is accomplished by a sensing bulb that is secured to the outlet of the evaporator coil at the suction line. When the temperature of the suction line increases at the sensing bulb (which is charged with refrigerant), the pressure in the sensing bulb increases- opening the valve. This is the only opening force upon the valve, so if the refrigerant charge is lost in the sensing bulb (powerhead) the TXV will close- starving the evaporator coil. If the sensing bulb is not attached to the suction line properly, the valve will likely open too much- flooding the evaporator.

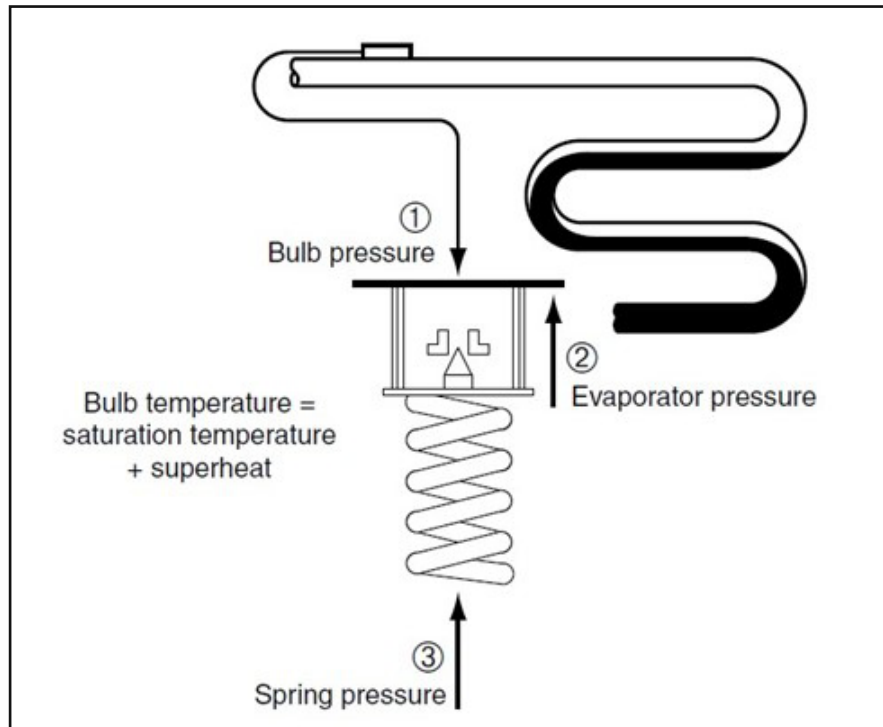

Fig. 6B.14.1 TXV 3 PRESSURES

6B.14.1 Three Pressures

There are three pressures at work on a TXV:

- (1) The bulb pressure which is the only opening force.
- (2) The evaporator pressure which is a closing force.
- (3) The spring pressure which is a closing force.

All the TXV's used in Traulsen Milk Cooler models are internally equalized, which means that the evaporator pressure closing force is applied internally from the inlet evaporator. The spring pressure is technically adjustable, but it should not be necessary to adjust any TXV on Traulsen equipment- as the superheat will be properly adjusted by Traulsen.

6B.14.2 Non-Bleed Type

The TXV used in Traulsen Milk Cooler equipment is a non-bleed (hard shut-off) type of TXV, which means that the pressures do not equalize during the off-cycle.

6B.14.3 Maximum Operating Pressure

The TXV used in a Traulsen Milk Cooler equipment is a MOP valve with Maximum Operating Pressure. The MOP valve is designed to limit the suction pressure from rising above the MOP value. Therefore, you will never see the suction pressure rise above the MOP value- not even during a hot pull down or after a defrost cycle.

6B.14.4 Measuring Superheat

When troubleshooting a TXV, it may become necessary to measure superheat- this can be done without connecting pressure gauges. All Traulsen Milk Cooler refrigeration systems are sealed without access for pressure test. Installing pressure test access valves should be the last resort. Superheat can be measured with two thermometers securely attached to refrigerant lines.

(T1) Measure the temperature at the inlet of the evaporator coil after the TXV valve body.

(T2) Measure the temperature at the outlet of the evaporator coil after the TXV sensing bulb.

Subtracting (T1) from (T2) will equal the superheat. The superheat should measure somewhere between 4° to 12°F.

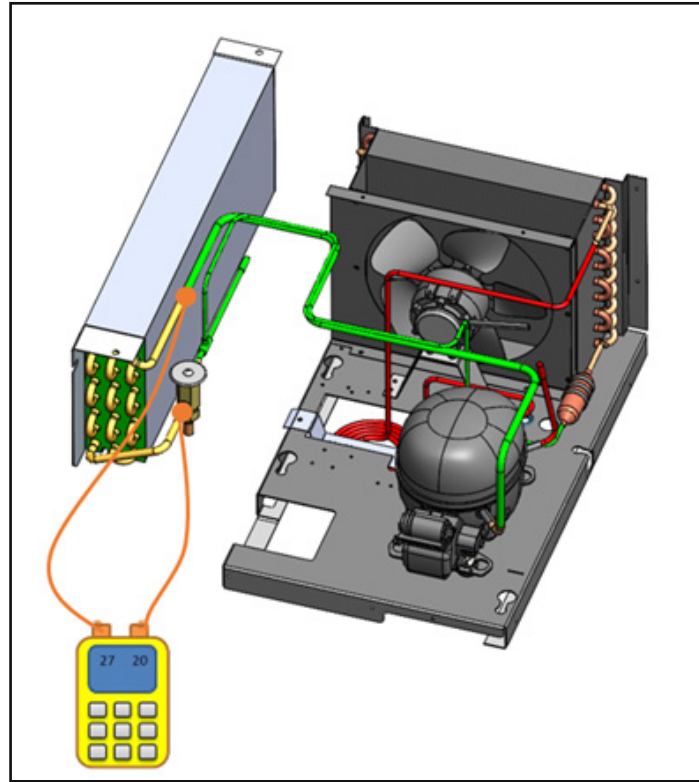

Fig. 6B.14.4 MEASURING SUPERHEAT

6B.14.5 Restrictions

If the flow of refrigerant becomes restricted at the TXV, the valve will be very cold to the point of freezing, but the evaporator coil will be warm with high superheat and subcooling. Both low side and high side pressures will drop. Although, if refrigerant is added to the system, the high side pressure will rise but the low side will not.

6B.14.6 Replacing the TXV

If it becomes necessary to replace the TXV, care should be taken to replace it with the exact OEM part. When brazing the TXV into the system, care should be taken not to overheat the valve. This is best accomplished by wrapping the valve with a cold wet rag. A dry nitrogen purge of 10 SCFH should be used to displace the oxygen to prevent the creation of an oxidized film inside the piping- which could lead to system contamination or a restriction. Too much nitrogen pressure will blow back through the joint and cause pinholes. After replacing the TXV, be sure to pull a deep vacuum of 200 microns.

6B.15 Removing the Refrigeration System

6B.15.1 Condenser Assembly

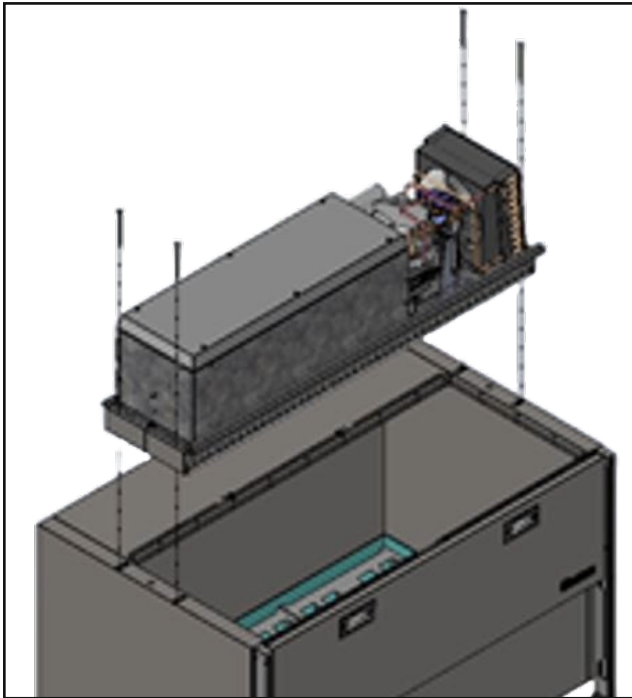

Fig. 6B.15.1a FASTENER LOCATIONS

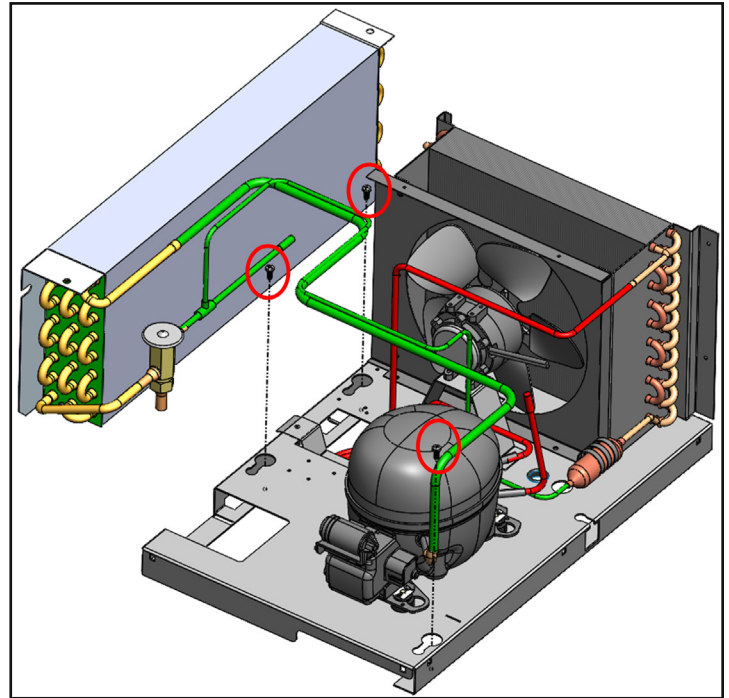

Fig. 6B.15.1b REMOVE FASTENER LOCATIONS

6B.15.2 Defrost Troubleshooting

Traulsen uses two different types of defrost on the Milk Cooler refrigerators. The last cabinet temperature before the defrost started will be displayed throughout the entire defrost cycle.

1. Off-Cycle Defrost

The off-cycle defrost is really an air over defrost. In other words, we shut off the compressor but continue to run the evaporator fan motor. During an off-cycle defrost the melting snowflake does not illuminate, but instead the fan icon. This type of defrost is time initiated every two hours, but then temperature terminated when the evaporator coil reaches 40°F or a maximum of 30 minutes. After the coil reaches the defrost termination temperature, two minutes of drip time will begin before the compressor is energized.

Traulsen uses OFF CYCLE defrost on the Milk Cooler refrigerators. The last cabinet temperature before the defrost started will be displayed throughout the entire defrost cycle.

1. Off-Cycle Defrost

The off-cycle defrost is really an air over defrost. In other words, we shut off the compressor but continue to run the evaporator fan motor. During an off-cycle defrost the melting snowflake does not illuminate, but instead the fan icon. This type of defrost is time initiated every two hours, but then temperature terminated when the evaporator coil reaches 40°F or a maximum of 30 minutes. After the coil reaches the defrost termination temperature, two minutes of drip time will begin before the compressor is energized.



Fig. 6B.15.2a. DISPLAY DURING OFF CYCLE DEFROST

*On Milk Cooler, Traulsen only uses one type of defrost:

7. General Wiring Diagrams

7.1 Refrigerator (Off-Cycle Defrost) 115 Volt

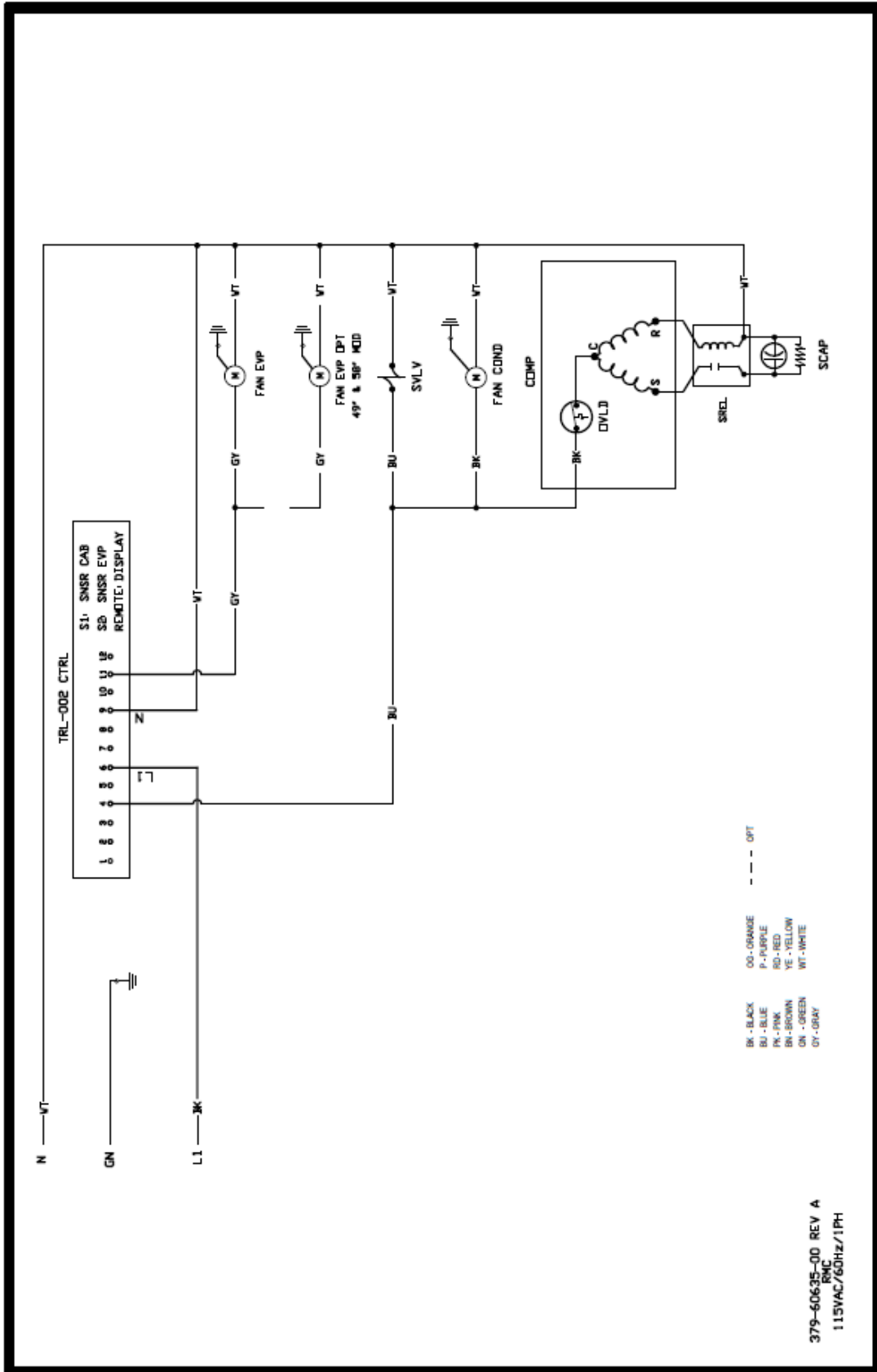

Fig. 7.1 REFRIGERATOR OFF-CYCLE DEFROST 115V

8. Part Number Index

8.1 Catalog Index

MODEL	COMPRESSOR	CONDENSER	CONDENSER FAN MOTOR
		2024 - CURRENT	2024 - CURRENT
RMC36	321-60310-00	322-60127-02	338-60063-00
RMC49	321-60297-00	322-60127-02	338-60063-00
RMC58	321-60297-00	322-60127-02	338-60063-00
MODEL	CONDENSER FAN SHROUD	EVAPORATOR	CAP TUBE/ TXV
		2024 - CURRENT	2024 - CURRENT
RMC36	701-61972-01	322-60167-01	325-60081-00
RMC49	701-61972-01	322-60167-01	325-60081-00
RMC58	701-61972-01	322-60167-01	325-60081-00
MODEL	SOLENOID VALVE	HUMP EXTERIOR	HUMP INTERIOR
		2024 - CURRENT	2024 - CURRENT
RMC36	N/A	506-70068-00	605-50089-01
RMC49	N/A	506-70070-00	605-50076-00
RMC58	N/A	506-70070-00	605-50076-00
MODEL	EVAPORATOR DRIP PAN	TANK	CONDENSER BASE
		2024 - CURRENT	2024 - CURRENT
RMC36	176-28052-01	609-60309-00	701-61803-01
RMC49	176-28052-01	609-60310-01	701-61803-01
RMC58	176-28052-01	609-60311-01	701-61803-01
MODEL	TOP EXT LH	TOP EXT RH	CHANNEL SYS SUPPORT
		2024 - CURRENT	2024 - CURRENT
RMC36	N/A	509-50320-00	510-10543-00
RMC49	509-50320-02	509-50320-01	510-10549-01
RMC58	509-50321-02	509-50321-01	510-10554-01

8.1 Catalog Index (CONTINUED)

MODEL	CONTROL BRACKET	EVAPORATOR SHROUD	DISPLAY BRACKET
		2024 - CURRENT	2024 - CURRENT
RMC36	N/A	614-60374-00	510-10624-02
RMC49	N/A	614-60374-01	510-10624-02
RMC58	N/A	614-60374-01	510-10624-02
MODEL	SYSTEM COVER	SYSTEM HARNESS	CONDENSER MTR BRCKT
		2024 - CURRENT	2024 - CURRENT
RMC36	701-62259-02	333-60469-01	N/A
RMC49	701-62242-02	333-60469-01	N/A
RMC58	701-62241-02	333-60469-01	N/A
MODEL	COMPRESSOR COMP BRKT	SUCTION LINE	LIQUID LINE
		2024 - CURRENT	2024 - CURRENT
RMC36	N/A	315-10070-01	315-10069-01
RMC49	N/A	315-10070-01	315-10069-01
RMC58	N/A	315-10070-01	315-10069-01
MODEL	COND TO FILTER	HOT GAS LOOP	COPPER COUPLING
		2024 - CURRENT	2024 - CURRENT
RMC36	N/A	315-10411-01	358-13087-06
RMC49	N/A	315-10411-01	358-13087-06
RMC58	N/A	315-10411-01	358-13087-06
MODEL	PROCESS TUBE		
		2024 - CURRENT	
RMC36	315-10040-02		
RMC49	315-10040-02		
RMC58	315-10040-02		

9. Warranty Information

NOTES STANDARD DOMESTIC WARRANTY

TRAULSEN & CO., INC. Warrants new equipment to the original purchaser, when installed within the United States against defective material and workmanship for one (1) year from the date of original installation. Under this warranty, TRAULSEN & CO., INC. will repair or replace, at its option, including service and labor, all parts found to be defective and subject to this warranty. The compressor part is warranted for an additional four (4) years. During this period TRAULSEN & CO., INC. will supply replacement compressor(s) if deemed defective, however, all installation, recharging and repair costs will remain the responsibility of the owner.

This warranty does not apply to damage resulting from fire, water, burglary, accident, abuse, misuse, transit, acts of God, attempted repairs, improper installation by unauthorized persons, and will not apply to food loss.

THERE ARE NO ORAL, STATUTORY OR IMPLIED WARRANTIES APPLICABLE TO TRAULSEN, INCLUDING BUT NOT LIMITED TO, ANY IMPLIED WARRANTY OF MERCHANTABILITY OR FITNESS FOR ANY PARTICULAR PURPOSE WHICH EXTEND BEYOND THE DESCRIPTION ON THE FACE HEREOF. TRAULSEN SHALL HAVE NO OBLIGATION OR LIABILITY FOR CONSEQUENTIAL OR SPECIAL DAMAGES, GROWING OUT OF OR WITH RESPECT TO THE EQUIPMENT OR ITS SALE, OPERATION OR USE, AND TRAULSEN NEITHER ASSUMES NOR AUTHORIZES ANYONE ELSE TO ASSUME FOR IT ANY OBLIGATION OR LIABILITY IN CONNECTION WITH THE EQUIPMENT OR ITS SALE, OPERATION OR USE OTHER THAN AS STATED HEREIN.

INTERNATIONAL COMMERCIAL WARRANTY

(for Canadian warranties see domestic US warranty)

TRAULSEN & CO., INC. Warrants to the original purchaser the Refrigeration Equipment manufactured and sold by it to be free from defects in material and workmanship under normal use and service for a period of one (1) year from date of shipment. Under this warranty, TRAULSEN & CO., INC. will reimburse the purchaser for the replacement of any part of said equipment (excluding dryers & refrigerant gas) which then proves to be defective. This warranty is void if said equipment or any part thereof has been subject to misuse, damage in transit, accident, negligence or alteration.

TRAULSEN'S standard warranty does not apply to Export Sales. Rather, for a period of one (1) year from date of original installation not to exceed Fifteen (15) months from date of shipment from factory, TRAULSEN:

will replace, F.O.B. factory, any defective parts normally subject to warranty.

will not cover the cost of packing, freight or labor such costs being the sole responsibility of the dealer.

THIS WARRANTY IS IN LIEU OF ALL OTHER WARRANTIES EITHER EXPRESSED OR IMPLIED AND CONSTITUTES TRAULSEN'S FULL OBLIGATION AND LIABILITY. WARRANTIES NOT AVAILABLE ON REMOTE MODELS.

NOTES:



4401 Blue Mound Road Fort Worth, Texas 76106 (USA)
Phone: 800.825.8220 | E-mail: service@traulsen.com | Website: traulsen.com
Form Number: TR00394 | Revision Date: 6-2024

Hours of Operation: Monday - Friday 7:30 a.m. - 4:30 p.m. (CST)