



# *SERVICE MANUAL*



## **TS Series Prep Table Service Manual**

**TS048HT, TS066HT, TS072HT, TS090HT**

**This manual is applicable for all models using:**

**R-290 (Propane) Refrigerants**

**Please Note:** This manual is intended for use with the above referenced equipment manufactured in or after 2023. To obtain a copy of the correct Service Manual to support the same products manufactured prior to this date, please contact Traulsen Service at **(800) 825-8220**

4401 Blue Mound Road Fort Worth, Texas 76106 (USA)  
Phone: 800.825.8220 | E-mail: [service@traulsen.com](mailto:service@traulsen.com) | Website: [traulsen.com](http://traulsen.com)  
Form Number: TR00410 | Revision Date: 8-2024

Hours of Operation: Monday - Friday 7:30 a.m. - 4:30 p.m. (CST)

# Table of Contents

1. Introduction .....	7
1.1 The Serial Tag .....	7
1.2 Serial Tag & Location .....	7
1.2.1 Reading the Serial Tag.....	7
1.3 Understanding TS-Series Model Numbers .....	7
1.4 Reading Traulsen Serial Numbers .....	8
1.5 Refrigerants.....	8
1.5.1 Terminology.....	8
1.5.2 R-290 Refrigerant .....	9
1.5.3 Troubleshooting Guide .....	9
1.6 Shipping and Assembly .....	10
1.6.1 Location .....	10
1.6.2 Packaging .....	10
1.6.3 Installing Legs or Casters .....	10
1.6.4 Shelf Pins .....	11
1.6.5 Installing the Condensate Evaporator.....	11
1.6.6 Cord & Plug .....	11
1.6.7 Power Supply.....	11
1.6.8 Wiring Diagram .....	11
1.6.9 Clearance .....	11
1.6.10 Cleaning the Exterior.....	11
1.6.11 Cleaning the Interior .....	11
1.6.12 Adjusting the Shelves .....	11
1.6.13 Replacing the Light Bulb .....	11
1.6.14 Troubleshooting Guide.....	11
1.6.15 Cleaning the Rail Area .....	12
1.6.16 Service Information .....	12
1.6.17 Flush Valve .....	12
1.6.18 Installing Optional Drawers.....	12
1.6.19 Setting Up the Rail .....	13
1.6.20 Pans.....	13
1.6.21 Freezing .....	14

## Table of Contents

1.6.21 Freezing .....	14
1.6.22 Shelf Clips for Door Models Setting up the Rail .....	14
1.6.23 Cutting Board Assembly .....	14
1.6.24 Prep Lid Assembly .....	14
1.6.25 Doors .....	15
1.7 Specifications .....	17
1.7.1 Prep Table 48" Specifications .....	18
1.7.2 Prep Table 66" Specifications .....	19
1.7.3 Prep Table 72" Specifications .....	20
1.7.4 Prep Table 90" Specifications .....	21
2. Preventative Maintenance .....	23
2.1 Inspect & Clean Unit .....	23
2.2 Inspect & Clean Door Gasket(s) .....	23
2.3 Clean Condenser Coil.....	23
3. Doors & Hardware .....	25
3.1 Hinges .....	25
3.1.1 Removing the Doors & Hardware .....	25
3.2 Adjustments .....	27
3.3 EZ-Clean Gaskets.....	28
3.4 Locks.....	29
3.4.1 Door Lock Assembly: Exploded View.....	29
3.4.2 Door Lock Replacement Instruction.....	30
4. Controls .....	33
4.1 Understanding the Display.....	33
4.2 Control Cover Removal & Components.....	34
4.2.1 Installing the Display.....	34
4.2.2 Accesing the Power Module (Control Board).....	35
4.3 Control Basics .....	36
4.4 Information Menu .....	36
4.5 Adjusting Cabinet Setpoint.....	36
4.6 Initiating a Defrost .....	36
4.7 Configuration Parameters .....	37

# Table of Contents

4.8 Technical Data .....	37
4.9 Temperature Reading Calibration .....	42
5. Sensor Location .....	42
5.1 Sensor Resistance Test .....	44
6A. UL/IEC/CE .....	45
6A.1 Electrical Outputs for Refrigerant Detection System .....	45
6A.2 Refrigerant Detection System Self-test Routine .....	45
6A.3 Serviceability .....	45
6A.4 Refrigerant Sensor Identification .....	45
6A.5 Qualification of Workers .....	45
6A.6 Information on Servicing .....	46
6A.6.1 Checks to the Area .....	46
6A.6.2 Work Procedure .....	47
6A.6.3 General Work Area .....	47
6A.6.4 Checking for Presence of Refrigerant.....	47
6A.6.5 Presence of Fire Extinguisher.....	47
6A.6.6 No Ignition Sources .....	47
6A.6.7 Ventilated Area .....	47
6A.6.8 Checks to the Refrigerating Equipment.....	47
6A.6.9 Checks to Electrical Devices .....	48
6A.7 Repairs to Sealed Components.....	48
6A.8 Repair to Intrinsically Safe Components .....	48
6A.9 Cabling .....	48
6A.10 Detection of Flammable Refrigerants .....	48
6A.11 Removal and Evacuation.....	49
6A.12 Charging Procedures .....	49
6A.13 Decommissioning .....	50
6A.14 Labeling .....	50
6A.15 Recovery .....	50
6A.16 Warning Notices.....	51
6B. Troubleshooting .....	53
6B.1 Additional Requirements & Precautions for R-290 (Propane) Systems.....	53
6B.2 Condensate Overflow Troubleshooting.....	54

## Table of Contents

6B.2.1 Condensate Overflow .....	54
6B.3 Leak Checking System .....	54
6B.4 Accessing the Refrigeration System.....	55
6B.5 Refrigerant Recovery.....	55
6B.6 Repair of Leaks.....	56
6B.7 System Evacuation.....	56
6B.8 Charging the System .....	56
6B.9 Remove Access Ports .....	56
6B.10 Compressor Troubleshooting .....	57
6B.10.1 Terminology .....	57
6B.10.2 Accessing the Compressor.....	57
6B.10.3 Compressor Not Running.....	58
6B.10.4 Testing the Windings of the Compressor .....	58
6B.10.5 Resistance & Amp Values of TS-Series Compressors .....	58
6B.10.6 Troubleshooting Compressor failure .....	58
6B.10.7 Measuring Inverter Power .....	58
6B.10.8 Troubleshooting compressor .....	58
6B.10.9 Troubleshooting Cont.....	59
6B.10.10 Troubleshooting Inverter.....	59
6B.10.11 Locked Up Compressor .....	60
6B.10.12 Current Climbs Above RLA.....	60
6B.10.13 Replacing the Compressor.....	60
6B.10.14 Compressor Wiring Schematics.....	61
6B.10.15 Compressor Short Cycles on Overload Protection .....	62
6B.10.16 Compressor Non-Start.....	63
6B.11 CF10B Electric Inverter .....	64
6B.11.1 General Product Specifications .....	64
6B.11.2 Technical Specifications.....	65
6B.11.3 Connectors .....	66
6B.11.4 Connection .....	67
6B.11.5 LED Indication .....	67
6B.11.6 Troubleshooting .....	68
6B.11.7 Diagnostics.....	69

## Table of Contents

6B.12 Evaporator Fan Troubleshooting .....	70
6B.12.1 Steps for Troubleshooting TS-Series Evaporator Fan.....	70
6B.12.2 Evaporator Unit .....	71
6B.12.3 Evaporator Fan.....	72
6B.13 Condenser Fan Troubleshooting.....	74
6B.13.1 Troubleshooting Condenser Fan Motor.....	74
6B.13.2 Motor Bearing Failure.....	74
6B.13.3 Removing the Condenser Fan Motor.....	75
6B.14 Troubleshooting Thermostatic Expansion Valve.....	76
6B.14.1 Three Pressures.....	76
6B.14.2 Non-Bleed Type.....	76
6B.14.3 Maximum Operating Pressure .....	76
6B.14.4 Measuring Superheat.....	77
6B.14.5 Restrictions.....	77
6B.14.6 Replacing the TXV .....	77
6B.15 Removing the Refrigeration System.....	78
6B.15.1 Condenser Assembly .....	78
6B.15.2 Defrost Troubleshooting.....	78
6B.15.3 Troubleshooting Guide for Solenoid Valve.....	79
6B.16 Service Parts List.....	80
7. General Wiring Diagrams .....	83
7.1 Refrigerator and Freezer 115 Volt .....	83
8. Warranty Information .....	84
NOTES .....	85

# 1. Introduction

Traulsen provides this manual as an aid to the service technician in installation, operation, and maintenance. When used properly, this service manual can help the service technician maintain, troubleshoot, and diagnose the majority of issues that may occur. While we believe that most aspects of service are covered in this manual, should you encounter a condition not addressed, please contact:



ITW Refrigeration  
Traulsen  
4401 Blue Mound Road  
Fort Worth, Texas 76106

Attn: Service Department  
Call for Technical Support:  
Tel: **(800) 825-8220**  
Email: **service@traulsen.com | p19parts@traulsen.com**

**IMPORTANT:** To improve your service communication experience, be sure to have the following available when contacting technical support:

- Serial Number**
- Model Number**
- A detailed description of the issue**

## 1.1 The Serial Tag

		4401 Blue Mound Rd. Ft. Worth, TX 76106 800-825-8220	
<small>MODEL: MODELO: MODELE:</small>			SCAN FOR SERVICE INFO
<small>S/N:</small>			
REFRIGERANT / REFRIGERANTE / RÉFRIGÉRANT			
<small>SYS1 (REFM):</small>			
<small>Hi Press. (PRESH):</small>			
<small>Lo Press. (PRESL):</small>			
<small>SYS2 (REFA):</small>			
<small>Hi Press. (PRESH):</small>			
<small>Lo Press. (PRESL):</small>			
Input Power (ELIN) - FOR INDOOR USE ONLY			
(Symbol 1) (Alt Safety / Other 1)	(Symbol 2) (Alt. San / Other 2)	(Symbol 3) (Alt. En. / Other 3)	(Symbol 4) (WEEE)
(Symbol 5) (Safety)	(Symbol 6) (Sanitation)	(Symbol 7) (Energy)	(Symbol 8) (Customer QR Code / Other 4)
Device/Part Number: PartNum		(UL/NSF Notes)	
COMPONENTS / COMPOSANTS / COMPONENTES			
<small>COMP AMPS:</small>		<small>EVAP FAN AMPS:</small>	
<small>COND FAN AMPS:</small>		<small>LIGHT WATTS:</small>	
<small>DEF HTR AMPS:</small>		<small>CTRL AMPS:</small>	
<small>DOOR HTR AMPS:</small>		<small>MIN AMPS:</small>	
<small>MAX AMPS:</small>			
370-60297-00 REV.A 11/20/14			

**Fig. 1.1**  
Sample  
Serial  
Tag

## 1.2 Serial Tag & Location

The serial tag is a permanently affixed label on which is recorded vital electrical and refrigeration data about your Traulsen product, as well as the model and serial number. This tag is in the upper left interior compartment of all TS-Series refrigerator and freezer models.

### 1.2.1 Reading the Serial Tag

- Model** = The model number of your Traulsen unit
- Serial (S/N)** = The permanent ID number of your Traulsen unit
- Refrigerant SYS1** = System 1 refrigerant type used and Refrigerant charge
- Design Pressure** = System 1 high and low pressure
- Refrigerant SYS2** = System 2 refrigerant type used and Refrigerant charge
- Design Pressure** = System 2 high and low pressure
- Volts** = Voltage
- Hz** = Cycle
- PH** = Phase
- Total Current** = Maximum amp draw
- Minimum Circuit Amps** = Minimum circuit ampacity
- Lights** = Light wattage
- Agency Labels** = Designates agency listings
- Components** = Component ratings

**NOTE:** Design pressure is the maximum pressure system components can handle and NOT the operating pressure.

## 1.3 Understand TS-Series Model Numbers

TS	PREP TABLE	WIDTH	ACCESS	CASTER SIZE
TS-SERIES	TS048HT	48	RH	6= 6 INCH CASTER
TS-SERIES	TS066HT	66	LH/RH	6= 6 INCH CASTER
TS-SERIES	TS072HT	72	LH/RH	6= 6 INCH CASTER
TS-SERIES	TS090HT	90	LH/LH/RH	6= 6 INCH CASTER

**Fig. 1.3**  
R-290 TS-Series Prep Table Model Numbers

\*\*\*All parts are optional, based on make/model\*\*\*  
\*\*(Part Numbers are subject to change)\*\*

## 1.4 Reading Traulsen Serial Number

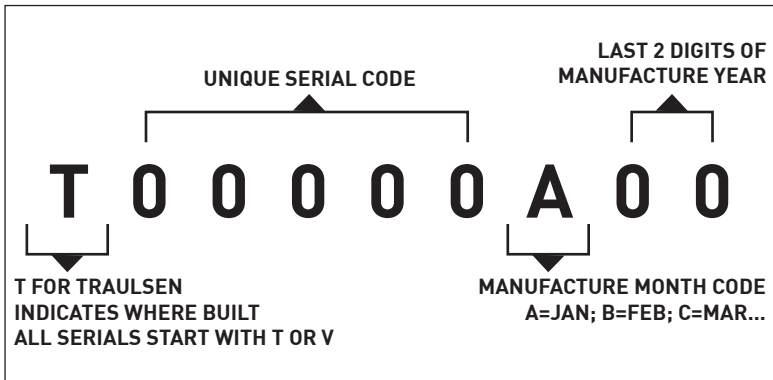


Fig. 1.4a  
Format if Manufactured Before April 2021

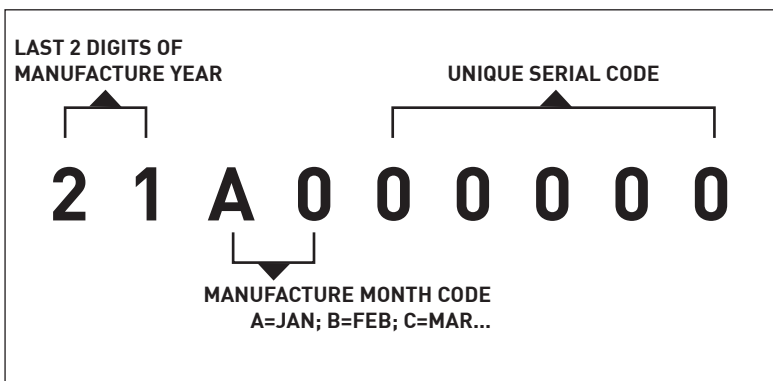


Fig. 1.4b  
Format If Manufactured After April 2021

## 1.5 Refrigerants

### 1.5.1 Terminology

**Temperature Glide** = The temperature difference between the starting and ending temperature of a refrigerant phase change within a system at a constant pressure. This can be seen on a Pressure Temperature chart as the difference between bubble and dew temperatures.

**Fraction of Refrigerant** = The change in composition of a blend because one or more of the components is lost or removed faster than the others.

**Bubble Point** = The temperature at which the liquid of a refrigerant blend starts to boil.

**Dew Point** = The temperature at which the vapor of a refrigerant blend starts to condense.

**Superheat** = The heat added to a refrigerant after its saturation point or heat added after a refrigerant boils

**Subcooling** = The heat removed from a refrigerant after its saturation point or heat removed after a refrigerant condenses.

- GWP: 3
- Refrigerant can be charged from either the liquid and vapor phase
- A-Gas refrigerant cylinders have dual port valves, making liquid off take easier
- Flammable and low toxicity with a safety classification of A3
- Compressors can be charged with a variety of oils contact the compressor manufacturer for more information
- Excellent thermodynamic properties leading to high energy efficiency
- Due to its flammable nature R290 (Propane) requires different charging, recovery procedures and equipment

**Formula** = R290 refrigerant has a chemical formula of C<sub>3</sub>H<sub>8</sub>, denoting its composition of three carbon atoms and eight hydrogen atoms per molecule.

**Molecular Weight (g/mol)** = With a molecular weight of 44.1 grams per mole, R290 is relatively lightweight, facilitating its use in refrigeration systems.

**Boiling Temperature °F (°C)** = R290 has a low boiling temperature of -43.8°F (-42.1°C), making it effective for cooling applications, especially in low-temperature environments.

**Global Warming Potential (GWP)** = With a GWP of 3, R290 is considered a low-impact refrigerant in terms of its contribution to global warming, aligning with environmentally conscious practices.

**Ozone Depletion Potential (ODP)** = R290 has an ozone depletion potential of 0, indicating that it does not harm the ozone layer, thus supporting efforts to preserve the Earth's atmosphere.

**Appearance** = This refrigerant appears as a colorless, liquefied compressed gas, allowing for easy identification and handling.

**Odor** = R290 is odorless, ensuring that its presence is not detectable by smell, which can be advantageous in various applications.

**Solubility in Water** = With a solubility of 0.0244 grams per liter, R290 exhibits limited solubility in water, which can be relevant for understanding its behavior in different environments.

**Vapor Pressure** = R290 operates at a vapor pressure of 109 pounds per square inch gauge (psi), influencing its performance and behavior within refrigeration systems.

**Flash point** = The flash point of R290 is -104°C (-155°F), indicating the temperature at which it can ignite in the presence of an ignition source, emphasizing the importance of proper handling and safety precautions.

By presenting these details in a user-friendly manner, users can better understand the characteristics and implications of utilizing R290 refrigerant in their systems.

### 1.5.2 R-290 (PROPANE) Refrigerant

R-290 (Propane) refrigerant is a refrigerant Traulsen uses in both low and medium temperature applications. This refrigerant is a single constituent refrigerant having no temperature glide.

Pressure (psi)	Temperature (°F)
5	-31.5
10	-21.3
15	-12.7
20	-5.1
25	1.7
30	7.9
35	13.6
40	18.9
50	28.4
60	36.9
70	44.6
80	51.6
90	58.1
100	64.2
110	69.9
130	75.2
140	80.3
150	85.2
160	89.8
170	94.2
180	98.4
190	102.4
200	106.4
210	110.1
220	113.8
230	117.3
240	120.7
250	124.0
260	127.3
270	133.4

**Table 1.5.2**  
**Pressure/ Temperature Chart For R-290 Refrigerant**

**NOTE:** Use the Dew temperatures when calculating superheat and bubble temperatures when calculating subcooling.

#### Pressure Guidelines for R290 Refrigerant in Freezers and Refrigerators:

For systems using R290 refrigerant, it is crucial to maintain the appropriate running and static pressures for optimal operation. Below are the typical pressure ranges for both freezers and refrigerators:

#### Refrigerator Running Pressures:

Low-side (Suction): Typically around 40-45 psi.

High-side (Discharge): Generally around 190 psi at 75°F ambient.

#### Static Pressure:

When the system is off, the refrigerant equalizes, and the static pressure for R290 refrigerant is usually around 100-110 psi at 75°F.

Maintaining these pressure ranges ensures proper system performance, energy efficiency, and longevity. Always verify pressures according to manufacturer specifications for each specific unit.



The refrigerant R290 (Propane) is flammable and it must be handled only by competent and responsible operators, under the conditions specified in the safety regulations in force.

R290 (Propane) is a flammable and explosive gas. Like other refrigeration systems, a unit charged with R290 is not serviceable at a consumer level. The use of special tools and proper procedures performed by licensed, trained and qualified professionals is required.

#### 1.5.3 Troubleshooting Guide

Before calling for service, please check the following:

- Is the electrical cord plugged in?
- Is the fuse OK or circuit breaker on?
- Clean condenser coil?
- Is the power switch on?

If after checking the above items and the unit is still not operating properly, please contact an authorized Traulsen service agent. A complete list of authorized service agents was provided along with your Traulsen unit. If you cannot locate this, you may also obtain the name of a service agent from the Tech Service page at [traulsen.com](http://traulsen.com). If service is not satisfactory, please contact our in-house service department at: Traulsen

4401 Blue Mound Road  
Fort Worth, TX 76106  
800.825.8220

Traulsen reserves the right to change specifications or discontinue models without notice.

## 1.6 Shipping And Assembly

### 1.6.1 Location

Select a proper location for your Traulsen unit, away from extreme heat or cold. Allow enough clearance between the unit and the side wall in order to make use of the door stay open feature at 120° (self-closing feature operates up to 90°). The door(s) must be able to open a minimum of 90° in order to make use of the maximum clear door width available.

### 1.6.2 Packaging

All Traulsen units are shipped from the factory bolted to a sturdy wooden pallet and packaged in a durable cardboard container. The carton is attached to the wooden skid with the use of large staples. These should first be removed to avoid scratching the unit when lifting off the crate.

Most exterior stainless steel surfaces have a protective vinyl covering to prevent scratching during manufacturing, shipping and installation. After the unit is installed in place of service, remove and discard the covering from all surfaces.

To remove the wooden pallet, first if at all possible, we suggest that the cabinet remain bolted to the pallet during all transportation to the point of final installation. The bolts can then be removed with a 3/4" socket wrench. Avoid laying the unit on its front, side or back for removal of the pallet.

**NOTE: DO NOT LAY THE UNIT ON ITS SIDE DURING INSTALLATION**

### Transportation or Installation

#### 1.6.3 Installing Legs or Casters

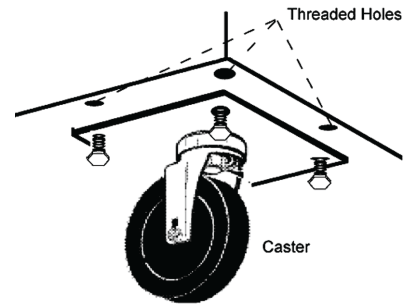
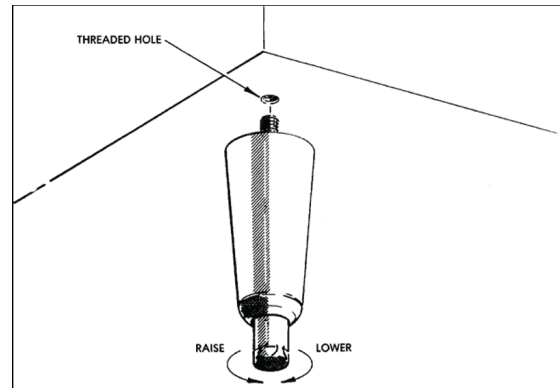
6" High stainless steel legs are supplied standard for all Traulsen reach-in and pass-thru units. Casters in lieu of legs are available as an optional accessory for the same models. These are shipped from the factory packed inside a cardboard box which is strapped to one of the shelves. Remove the nylon strap and open the box, it should contain either four (4) legs or four (4) casters and sixteen (16) bolts.

### THE CABINET MUST BE BLOCKED AND STABLE BEFORE INSTALLING LEGS OR CASTERS.

To install the legs or casters, first raise and block the reach-in a minimum of 7" from the floor. For installing legs, thread the legs into the threaded holes on the bottom of the cabinet. Be certain that all legs are tightly secured (legs and casters should be tightened to 300 inch/pounds, max). When the unit is set in its final position, it is important for proper operation that the unit be level. The legs are adjustable for this purpose; turn the bottom of the leg counter-clockwise to raise it, clockwise to lower it. Level the unit from front to back as well as side to side in this manner, using a level placed in the bottom of the cabinet.

### ⚠ WARNING

Please note that Traulsen units are not designed to be moved while on legs. If the unit requires moving, a pallet jack or forklift should be used to prevent damage. For installing casters, the casters are "plate" type, and require the use of four (4) bolts each to secure them firmly to the cabinet bottom at each corner. The caster bolts are tightened using a 1/2" socket wrench.



#### 1.6.4 Shelf Pins

The unit is supplied with shelves and shelf pins installed. Check all shelf pins to assure they are tightened down as they may have come loose during shipping. Rotate the pins clockwise until they are secured against the side of the cabinet.

#### 1.6.5 Installing the Condensate Evaporator

A condensate evaporator is normally supplied on all self-contained models (remote models require provision of either a floor drain or an optional condensate evaporator). On those models supplied with a top-mounted evaporator coil compartment, the condensate evaporator is also secured to the top of the cabinet. Check that the condensate pan is properly located underneath the drain tube.

**NOTE:** The use of the “P-TRAP” supplied is required. Failure to use this component may allow cold air to migrate down the drain line, resulting in condensation on the rear of the cabinet.

A remote model is normally supplied configured for condensate to be run to a floor drain unless purchased with a condensate evaporator. The installer is responsible for making the required extension to the floor drain in accordance with good practice and local regulations.

#### 1.6.6 Cord & Plug

Most self-contained models are supplied with a cord & plug attached. It is shipped coiled at the top of the cabinet, secured by a nylon strip. For your safety and protection, all units supplied with a cord and plug include a special three-prong grounding plug on the service cord. Select only a dedicated electrical outlet with grounding plug for power source.

**NOTE:** Do not under any circumstances, cut or remove the round grounding prong from the plug, or use an extension cord.

#### 1.6.7 Power Supply

The supply voltage should be checked prior to connection to be certain that proper voltage for the cabinet wiring is available (refer to the serial tag to determine correct unit voltage). Make connections in accordance with local electrical codes. Use qualified electricians.

Use of a separate, dedicated circuit is required. Size wiring to handle indicated load and provide necessary over current protector in circuit (see amperage requirements on the unit's serial tag).

#### 1.6.8 Wiring Diagram

Refer to the wiring diagram for any service work performed on the unit. Should you require one, please contact Traulsen Service at **(800) 825-8220**, and provide the model and serial number of the unit involved.

#### 1.6.9 Clearance

In order to assure optimum performance, the condensing unit of your Traulsen unit **MUST** have an adequate supply air for cooling purposes. Therefore, the operating location must either have a minimum of 12" clearance overhead of the condensing unit or allow for unrestricted air flow at the back of the unit. Clearance of at least 12" above is required in order to perform certain maintenance tasks.

#### 1.6.10 Cleaning the Exterior

Exterior stainless steel should be cleaned with warm water, mild soap and a soft cloth. Apply with a dampened cloth and wipe in the direction of the metal grain.

Avoid the use of strong detergents and gritty, abrasive cleaners as they may tend to mar and scratch the surface. Do NOT use cleansers containing chlorine, this may promote corrosion of the stainless steel.

Care should also be taken to avoid splashing the unit with water, containing chlorinated cleansers, when mopping the floor around the unit.

For stubborn odor spills, use baking soda and water (mixed to a 1 TBSP baking soda to 1 pint water ratio).

#### 1.6.11 Cleaning the Interior

For cleaning both stainless steel and anodized aluminum interiors, the use of baking soda as described in section “1.6.13” is recommended. Use on breaker strips as well as door gaskets. All interior fittings are removable without tools to facilitate cleaning.

#### 1.6.12 Adjusting the Shelves

For shelves mounted on pins, first select the desired location and remove the white plastic covers in the interior back and sides by rotating them counter-clockwise. Remove the shelf pins by rotating them counter-clockwise. Install the pins in the desired location by rotating clockwise. Make sure the pin is securely tightened down. Do not over tighten. Slide the shelf into its new position, and replace the white plastic covers into the holes vacated by the shelf pins.

#### 1.6.13 Replacing the Light Bulb

All Traulsen optional tube style display lighting is available (except for sliding glass door models for which fluorescent lights are supplied standard).

The standard LED bulb is a 115 or 230 volt / 4-watt, T-6 intermediate clear refrigerator lamp. It is mounted at the top front of the cabinet at the center and is located behind a plastic light cover on refrigerator and freezer model.

To replace the bulb, first remove the light cover (if so equipped). This can be accomplished by squeezing it together on both sides until it comes free. Replace the light bulb, then squeeze both sides of the light cover together and replace in its original position.

#### 1.6.14 Troubleshooting Guide

Before calling for service, please check the following:

Is the electrical cord plugged in?

Is the fuse OK or circuit breaker on?

Clean condenser coil?

Is the power switch on?

If after checking the above items and the unit is still not operating properly, please contact an authorized Traulsen service agent. A complete list of authorized service agents was provided along with your Traulsen unit. If you cannot locate this, you may also obtain the name of a service agent from the Tech Service page at [traulsen.com](http://traulsen.com). If service is not satisfactory, please

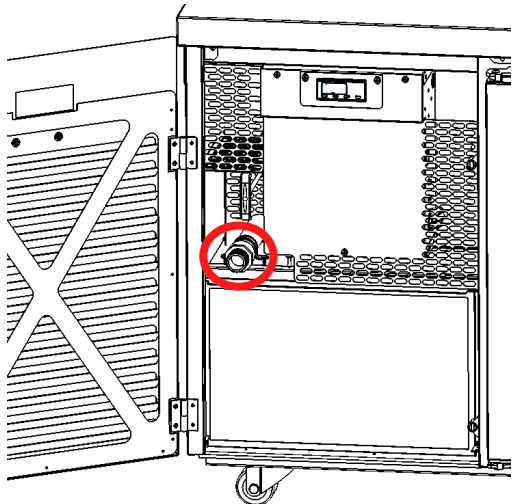
contact our in-house service department at: Traulsen  
4401 Blue Mound Road  
Fort Worth, TX 76106  
800.825.8220

Traulsen reserves the right to change specifications or discontinue models without notice.

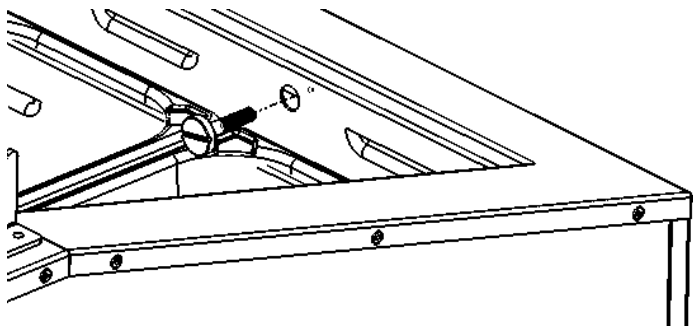
### 1.6.15 Cleaning the Rail Area

**WARNING: DISCONNECT ELECTRICAL POWER SUPPLY BEFORE CLEANING ANY PART OF THE UNIT.**

Temperature rail is equipped with drain and flush valve. Up to 5 gallons of water can be used to clean rail compartment.



For excessive spills the front and rear baffle in the rail are removable by un-screwing the thumb screws.



Air baffles can be cleaned in a sink using caution not to lose fasteners.

**NOTE: Use caution in avoiding getting excessive water down in the cabinet ducts with outer air ducts removed.**

If the temperatures are different; meaning the display reads much WARMER than the actual return air, then either the cabinet sensor is in the wrong location, or the cabinet sensor is defective. At this point, DON'T jump to conclusions. You must diagnose which is the issue. The location of the sensor is to be about 6.5 inches above and in line with the drain line and inserted into the cabinet the proper depth. The proper depth is 4.5 inches for all, except for the TS048HT which is 6 inches. Begin by marking the cabinet sensor at the point it enters

into the left side of the return air wall. Do this so when the sensor is removed from the return air cavity, you will know exactly

how far it extended into the cavity. Gently pull the cab sensor out.

Since they are silicone in place, there will be some silicone that needs to be broken loose. Once the sensor is removed, place the sensor in an ice bath (a lot of ice, a little water) stir gently for a few minutes. If the sensor is accurate you will read about 32 degrees on the display. If it is not, then replace the sensor, making sure it is inserted into the cavity the proper depth. Once the sensor is either verified as reading proper or was not inserted to the proper depth, place the sensor back into the return cavity with the proper insertion depth. Finally, be sure to SILICONE the sensor in place where it penetrates the return wall cavity, so it won't move from its proper location.

### 1.6.16 Service Information

To purchase replacement parts or to speak to service support for Traulsen and most Hobart Refrigeration units please contact our Ft. Worth facility by phone at 800.825.8220 or fax to 817.740.6748 (parts) or 817.740.6757 (service).

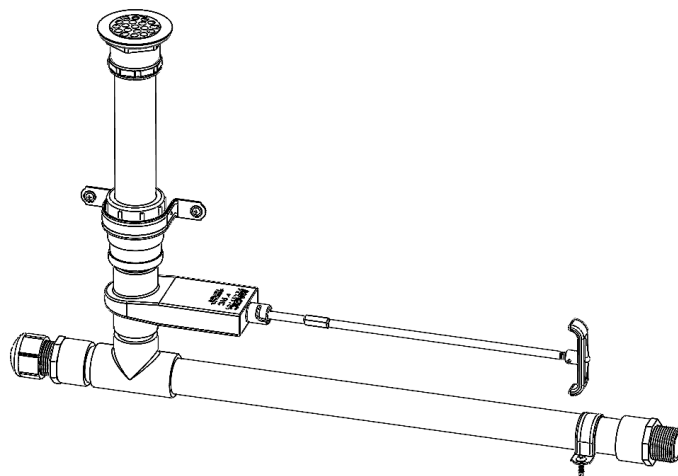
To obtain other service information you may log onto:

1. [traulsen.com](http://traulsen.com)
2. Select Service & Parts Tab (upper right of screen)
3. Select one of the following: Service Finder, Service Parts-Manuals, Parts Pricing & Warranty Registration

NOTE: When calling for service support, please make sure you have model and serial number of unit available.

### 1.6.17 Flush Valve

Drain with valve 1.5 push/ pull valve.



**Flush Valve Replacement**  
P/N: 900-61112-01

### 1.6.18 Installing Optional Drawers

Doors are supplied standard on all TS Series models. However, we have engineered our refrigerator models with a drop-in feature that allows you to easily convert door(s) into two 6" deep drawers or three 4" deep drawers.

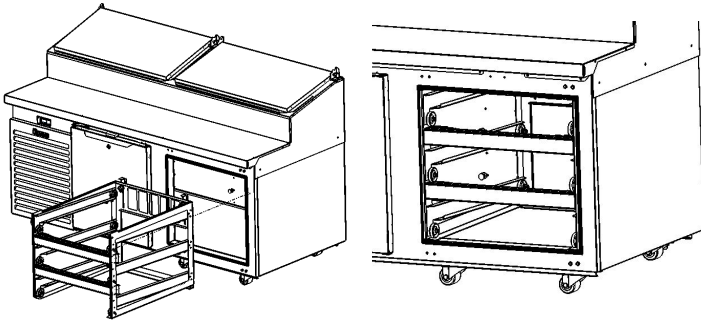
The door(s) on the refrigerator models can easily be converted

to drawers in the field. To begin the process, open the door to its maximum position. Support the non-hinged end of the door so minimum movement occurs. When the bolts from the lower hinge plate are removed, remove the lower hinge plate and then the door from the top hinge bracket plate and then the door from the top hinge bracket. The hinge plate pin and plastic bushing will remain in the top hinge plate.

**NOTE: The lower hinge plate is under spring tension.**

Once the door(s) have been removed, Insert drawer frame as shown below.

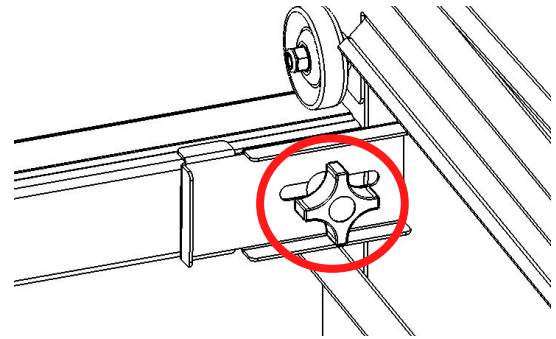
**NOTE: Undercounter model drawings shown below.**



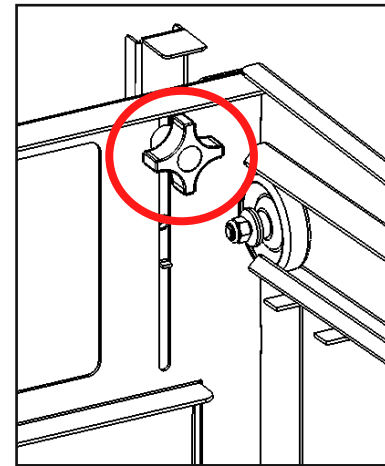
Once the drawer frame has been inserted, the drawer frame module can be installed by tightening the black front and back clamping knobs (2 of each) located on the cross rail locks and liner locks. Slide the front cross rail locks towards the center of the drawer frame module and allow the liner locks to drop down from the top of the liner. Insert the door frame module push towards the back of the unit. The entire frame assembly is now installed and ready for use.

**NOTE: Repeat process for multiple drawer inserts.**

Drawers	Part Number
2DRWR Frame	550-10192-00
1-1/9 Pan Drwr/ face Assy	<a href="#">550-10190-00</a>
3 DRWR Frame	550-10193-00
1-1/9 Pan 3 Drwr/ face Assy	<a href="#">550-10196-00</a>
Assy Drwr Pan Frame	550-10188-00
Adapter bars 20'L ,1'W	<a href="#">701-61258-00</a>
2 Pan FTB DRWR Frame	550-10153-00
DRWR FTB lock BTM 6' pans	<a href="#">550-10108-00</a>
DRWR FTB 6' pans	<a href="#">550-10418-00</a>



**Front Clamping Knobs/ Cross Rail Locks**



**Back Clamping Knobs**

#### 1.6.19 Setting Up the Rail

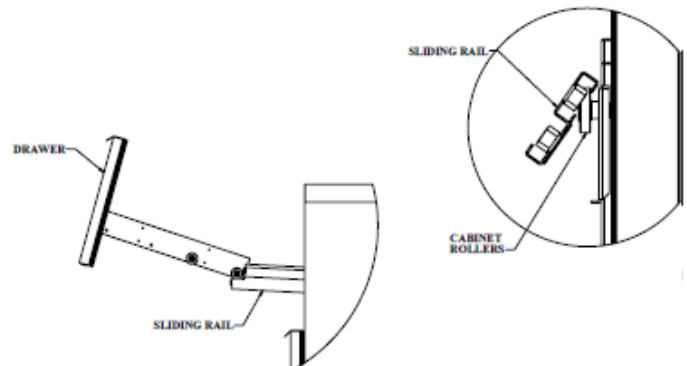
Install pans in all pan spaces in the rail. Rest each pan evenly on the front and back support ledges. Do not use uneven or bent pans, as these will allow circulating cold air to escape.

Allow the unit to reach operating temperature before loading any food product. Load only refrigerated product at 360F or below.

All pan spaces should be filled, even if some pans are empty (even during nighttime storage).

#### 1.6.20 Pans

Standard TS Series models are designed to operate with full, half or third size pans without the use of adapter bars. Other fractional size pans can be used with optional adapter bars available from Traulsen. 4" deep pans provide the best temperature performance in the rail. Both 2" & 6" deep pans will also perform to NSF7 temperature requirements.



### 1.6.21 Freezing

“Box Too Cold – Freezing Product”

Begin by determining if our display temperature is the SAME as the return air OR if the display reads much WARMER than the return air. Determining this first will give a clearer idea of the proper solution.

If the temperatures (display and return air) are the SAME, and product is freezing, check the sensor temperature readings (system, manually) this may be causing the compressor to stay on even though it is not 36.0F degrees. . see chart for more troubleshooting tips

### 1.6.22 Shelf Clips for Door Models Setting up the rail

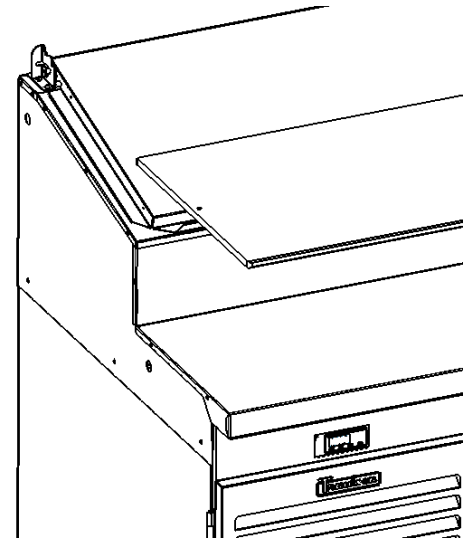
Shelves and shelf clips are shipped with the unit. For each shelf, insert Four (4) shelf clips into the pilaster slots at the same height. The shelf clips have a small projection on top which holds the shelf position and prevents it from slipping forwards. After installing shelf clips on pilasters. Place shelves on clips.

### 1.6.23 Cutting Board Assembly

On sandwich prep tables, the cutting board may require assembly at the site.

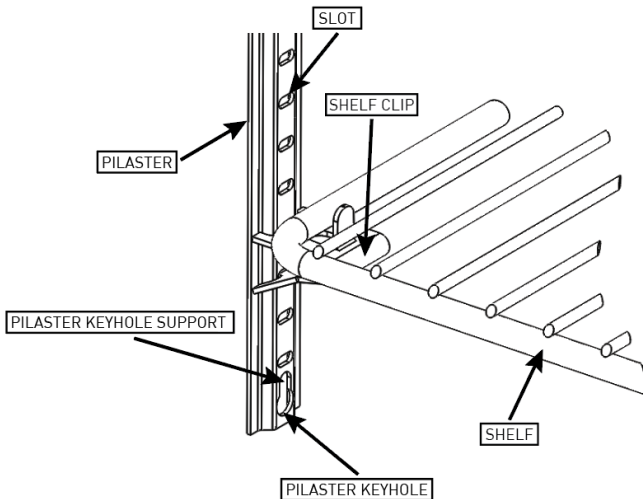
Place cutting board on cabinet, properly align & install screws to secure in place. The cutting board is field reversible, reverse process to reverse cutting board.

**Note: The lid(s)/cover(s) are installed at the factory. No assembly required.**



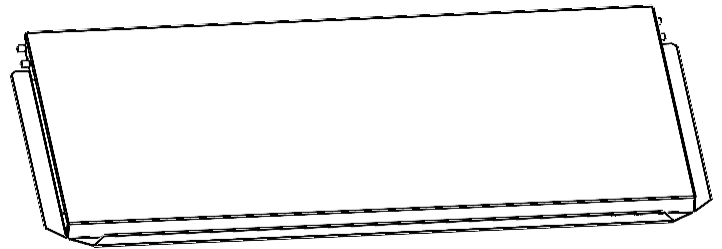
Cutting Board Install

Lid Dimensions	Part Number
90" Cutting Board (4)	340-60172-06
72" Cutting Board (3)	340-60172-00
66" Cutting Board (2)	340-60172-02
48" Cutting Board (2)	340-60172-00



### 1.6.24 Prep Lid Assembly

Installation for Traulsen TS Prep Table Lid Hinge Bracket Replacement.



Lid Dimensions	Part Number
48" Phantom Assm	SER-60579-00-
66" Phantom Assm	SER-60575-00
72" Phantom Assm	SER-60581-00
90" Phantom Assm	SER-60582-00

#### Bracket is loose:

The following parts would be required to repair all 4 lid hinge bracket on a TS cabinet if the screws just came loose and “Holes are not stripped out”.

Parts Required: **Bracket kit part# SER-60634-00**

- Left Hinge Bracket (2 ea.) - Included in kit
- Right Hinge Bracket (2 ea.) - Included in kit
- 10-32 Button Head Screws (2 per bracket, 8 total) - Included in kit
- Loc-Tite or similar thread adhesive (**Not included in Kit**)

**Bracket Mounting Plate Stripped:**

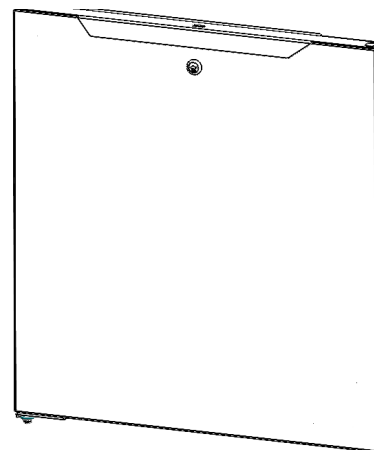
If the lid hinge bracket screw “**Holes are stripped and cannot be reused**”, use the following procedure: (**Drill, Tap, and Larger Dia. screws not included in Kit**)

- Drill out the existing holes to the next screw size larger than the original 10-32 mounting screw.
- Tap the new hole for the size of the new screws that are to be used
- Install the lid brackets using the larger screws and seal with Lok-Tite adhesive.

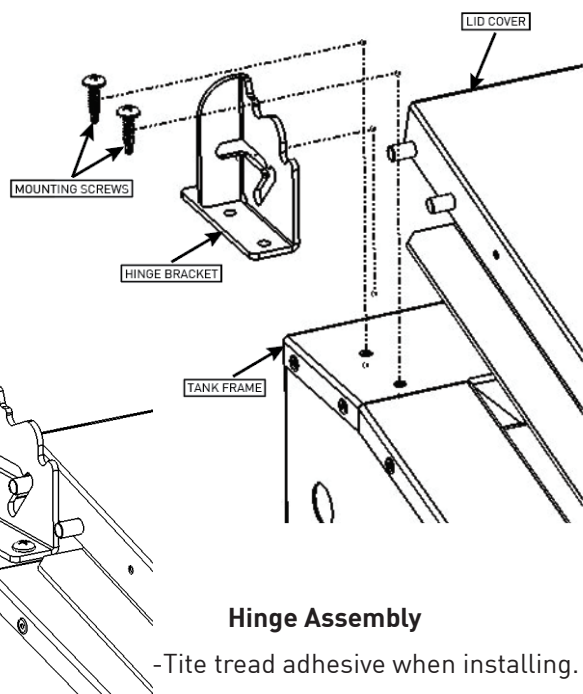
\*\*Another procedure is to drill out the existing holes for a 10-32 Riv-Nut insert and attach the lid hinge bracket with 10-32 screws also using Lok-Tite thread adhesive.

**(Rivnuts, Drill, and Installation tools not included in kit)**

**Note:** there is a metal backing plate already installed at the factory inside the metal outer layer of the cabinet for the lid hinge brackets .



Doors	Part Number
Door HR 1 Section	200-60788-01
Door HR 2 Section	200-60788-02
Door HR 3 Section	200-60788-03
Door HL 1 Section	200-60787-01
Door HL 2 Section	200-60787-02
Door HL 3 Section	200-60787-03



If additional assistance is needed, please call Traulsen Technical Service @ 1-800-825-8220

**Note: The lid(s)/cover(s) are installed at the factory. No assembly required.**

**1.6.25 Doors**

**Inspect Door/pan Gasket:**

Examine the door gasket for any signs of wear, cracking, or damage. If the gasket is damaged, remove the old gasket by pulling it away from the door frame and install a new one by pressing it firmly into place.

**Check Door Hinges:**

Inspect the door hinges for proper alignment and secure attachment. Using a Phillips screwdriver, tighten any loose screws to ensure the door is properly aligned and closes securely. Verify that the door closes fully and that the gasket provides an airtight seal. Ensure the door operates smoothly without any obstruction or misalignment. If the door continues to have issues after servicing, recheck hinge alignment and gasket fitment. Replace parts as necessary, following manufacturer guidelines

**Regular inspection and maintenance of the door and its components will help maintain optimal performance and energy efficiency.**

Maintaining the doors on a TS prep table is crucial for ensuring efficient operation and prolonging the life of the unit. Proper door service enhances the unit's performance, ensuring a tight seal to maintain consistent temperatures and reduce energy consumption. Additionally, regular maintenance minimizes downtime and costly repairs.

**Replacement Parts** The unit's design allows for straightforward replacement of wear-and-tear items, such as gaskets and hinges. These parts can be sourced and swapped out by technicians without extensive disassembly.

**A faulty door gasket is one of the most common reasons for temperature fluctuations in refrigeration units. Check the gasket for any cracks, tears, or brittleness that may compromise the seal.**

**Replacement Process:** If the gasket is damaged, remove the old one by pulling it away from the door frame. Install a new gasket by pressing it firmly into place, ensuring no gaps between the door and the frame.

According to standard service practices, gaskets should be inspected at least every six months to maintain optimal sealing efficiency. Door misalignment can lead to uneven wear on the gasket and strain the hinges, reducing the door's lifespan. Inspect the hinges for signs of wear, or misalignment.

Tighten loose screws and ensure the hinges are correctly aligned with the door frame. Misaligned hinges can be adjusted by loosening the mounting screws and repositioning the door.

After completing repairs or adjustments, verify the integrity of the door seal by ensuring no air leaks around the gasket. **Use a dollar bill test** (place a dollar between the door and frame, then close the door; if it pulls out easily, the seal may be compromised).

Open and close the door several times to ensure smooth operation and that it self-closes as designed.

After servicing, monitor the internal temperature to ensure that the door service has restored optimal cooling performance.

## Troubleshooting

**Persistent Door Issues:** If the door continues to malfunction after servicing, double-check for proper gasket installation and hinge alignment. Excess wear may require complete hinge or self-closing mechanism replacement.

**Door Not Closing Properly:** Ensure the unit is level. An uneven surface can lead to improper door function and may require the unit to be repositioned or leveled.

By regularly servicing the doors, technicians can prevent common issues such as temperature instability, excessive compressor cycling, and higher energy consumption, ultimately extending the lifespan of the prep table and maintaining food safety standards.

## Construction and Hardware

**Exterior:** Stainless steel top, front, and sides; galvanized steel back and bottom.

**Interior:** Stainless steel construction with 2" insulation on top, bottom, and sides.

**Ingredient Rail:** 12" wide raised rail for full, half, or third size pans (pans not included). Adapter bars required for other pan sizes (not included). Fits 6" deep pans. Includes stainless steel insulated lift-up cover with two open positions.

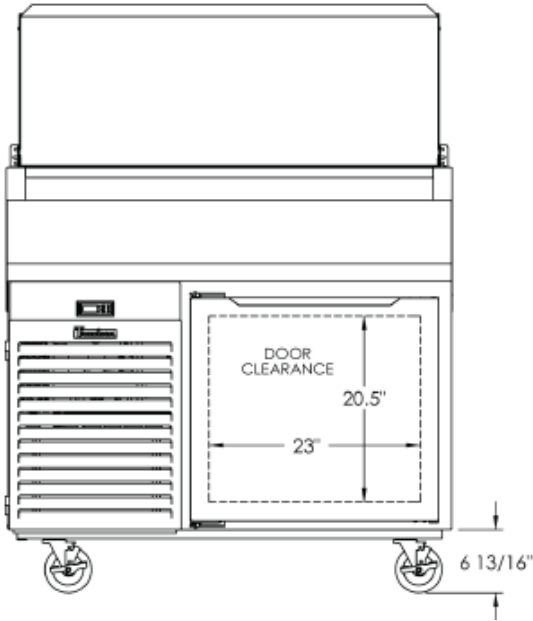
**Doors:** Self-closing hinges with metal handle and gasket guard. Interior

**Shelving:** Two wire shelves per door, mounted on shelf pins. Maximum load: 225 lbs per shelf.

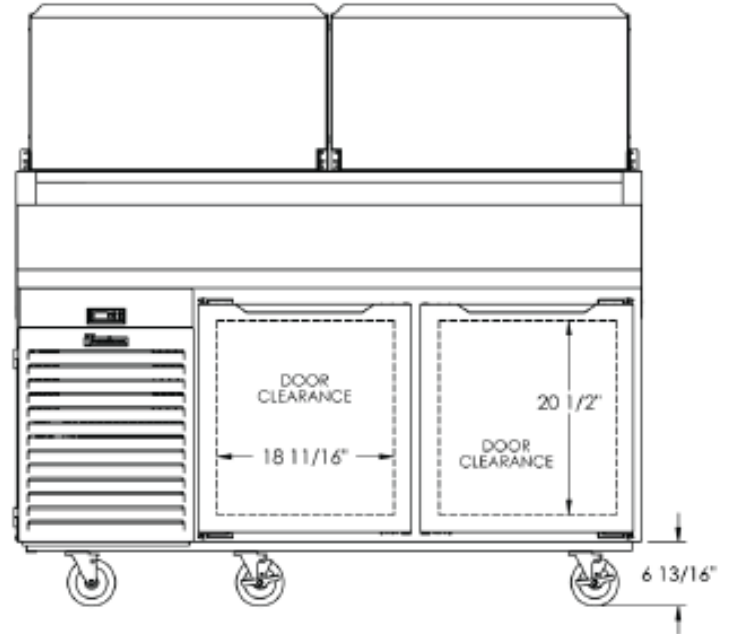
## 1.7 Specifications

DIMENSIONS	1 Section Cabinet	2 Section Cabinet	2 Section Cabinet	3 Section Cabinet
Height - Overall on 6" Casters	48 3/8" (122.9 cm)	48 3/8" (122.9 cm)	48 3/8" (122.9 cm)	48 3/8" (122.9 cm)
Width	48" (121.9 cm)	66" (167.6 cm)	72" (182.9 cm)	90" (228.6 cm)
Depth	36" (91.4 cm)	36" (91.4 cm)	36" (91.4 cm)	36" (91.4 cm)
Net Capacity cu. ft.	9.5 (269l)	15.7 (444.6l)	17.9" (506.9l)	24.4 (690.9l)

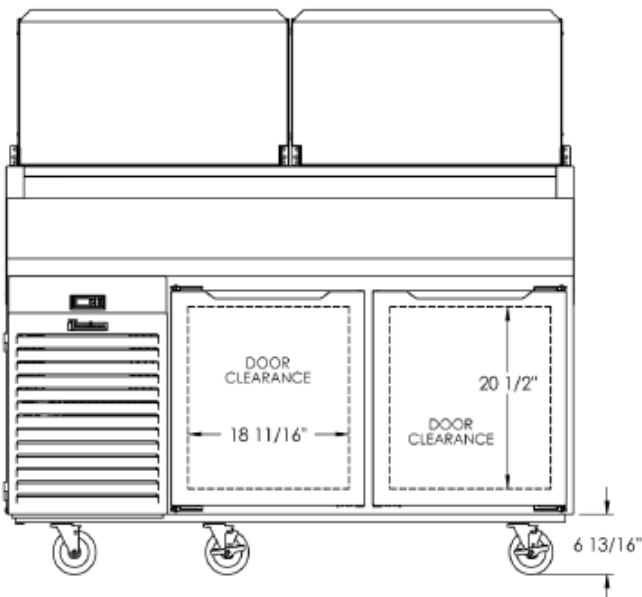
**Table 1.7**  
**TRAUlsen Cabinet Specifications**



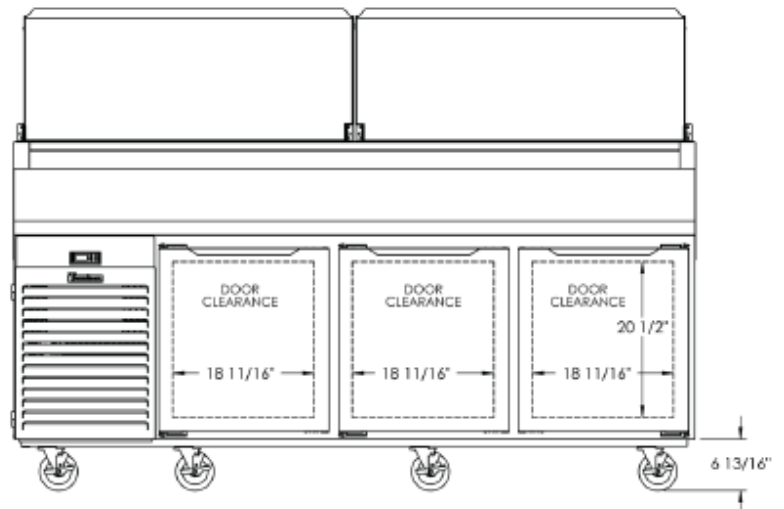
**Fig. 1.7a**  
**Front View of 48" Cabinet**



**Fig. 1.7b**  
**Front View of 66" Section Cabinet**



**Fig. 1.7c**  
**Front View of 72" Section Cabinet**



**Fig. 1.7d**  
**Front View of 90" Section Cabinet**

### 1.7.1 Prep Table 48" Specifications

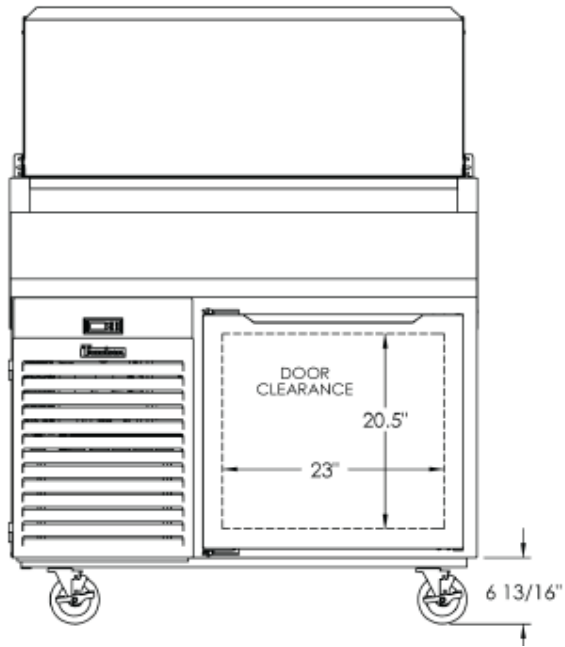


Fig. 1.7.1a  
Front View of 48" Cabinets

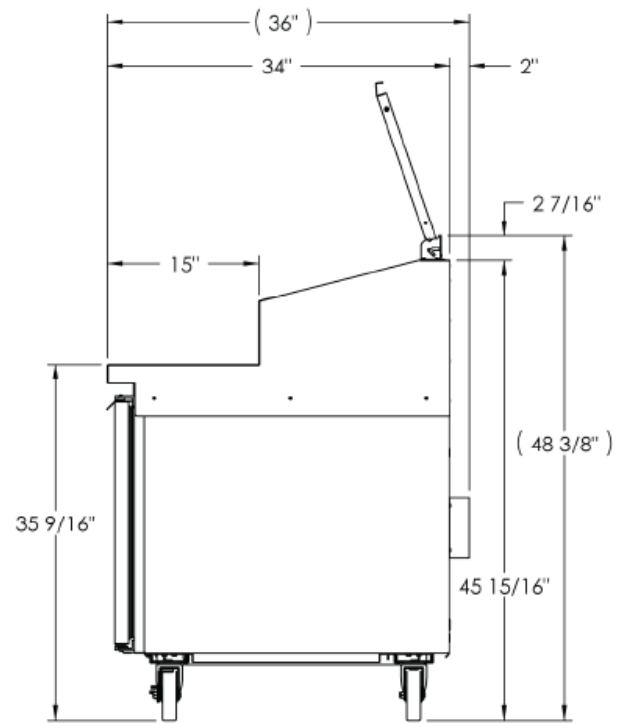


Fig. 1.7.1b  
Side View of 48" Cabinets

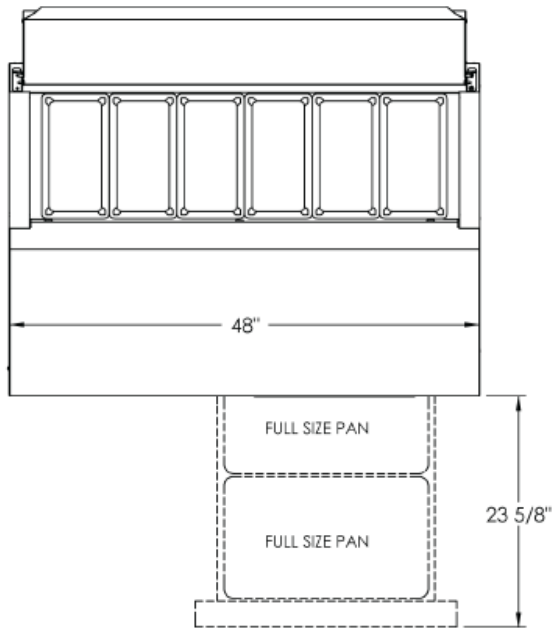


Fig. 1.7.1c  
Top View of 48" Cabinets

## 1.7.2 Prep Table 66" Specifications

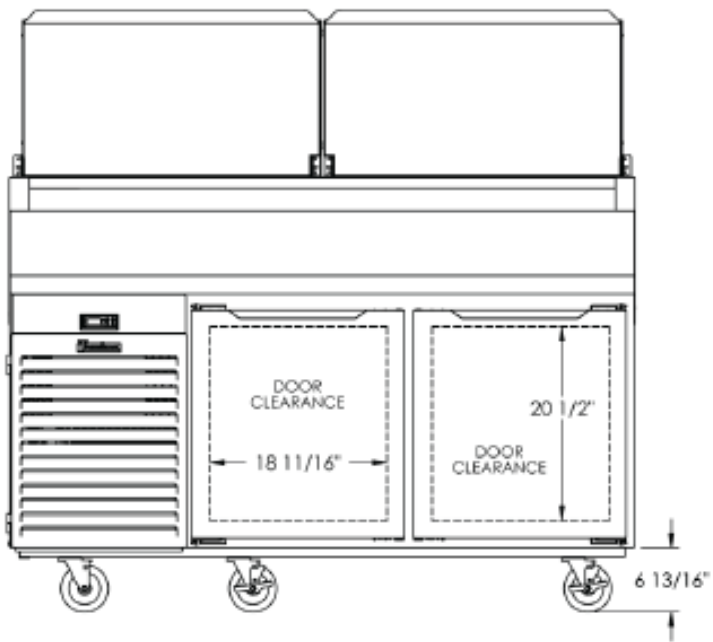


Fig. 1.7.2a  
Front View of 66" Cabinets

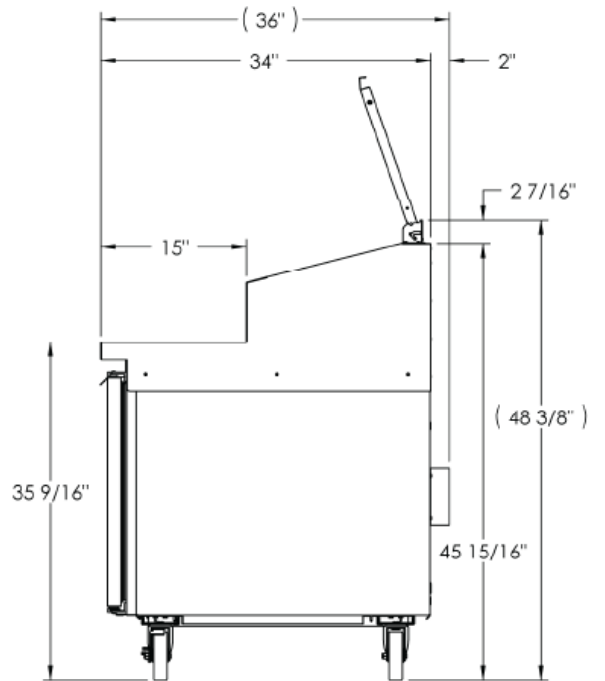


Fig. 1.7.2b  
Side View of 66" Cabinets

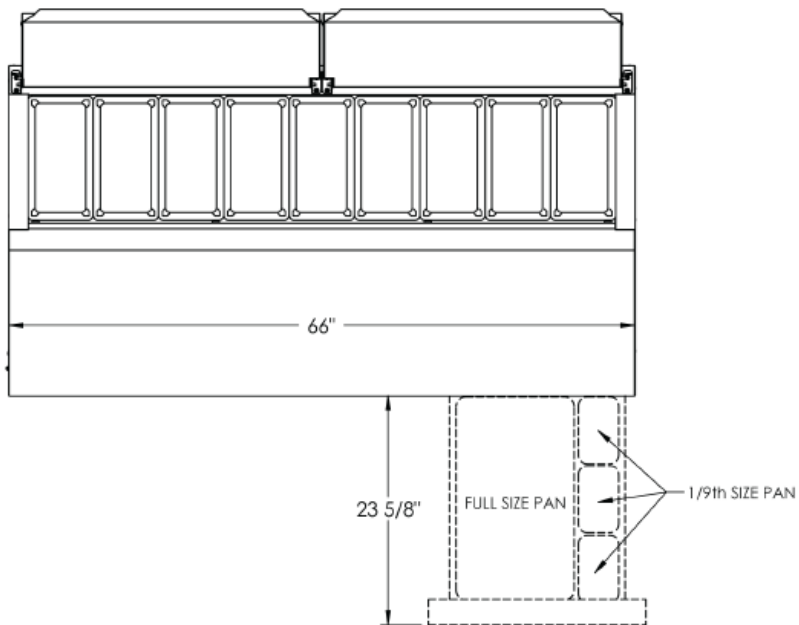
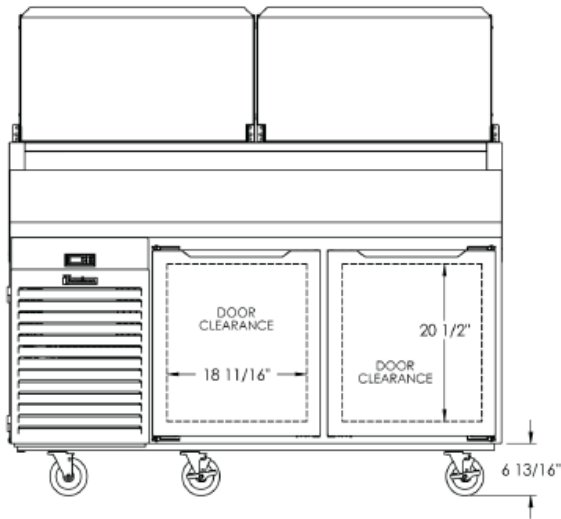
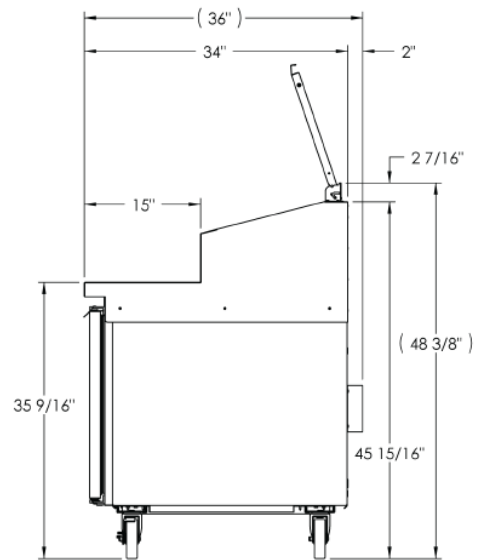


Fig. 1.7.2c  
Top View of 66" Cabinets

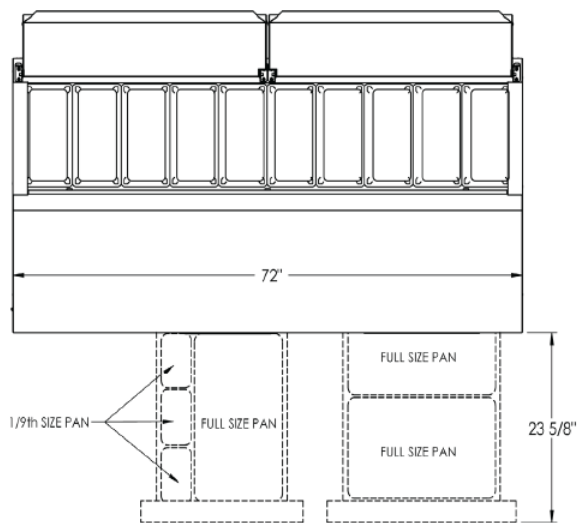
### 1.7.3 Prep Table 72" Specifications



**Fig. 1.7.3a**  
Front View of 72" Cabinets

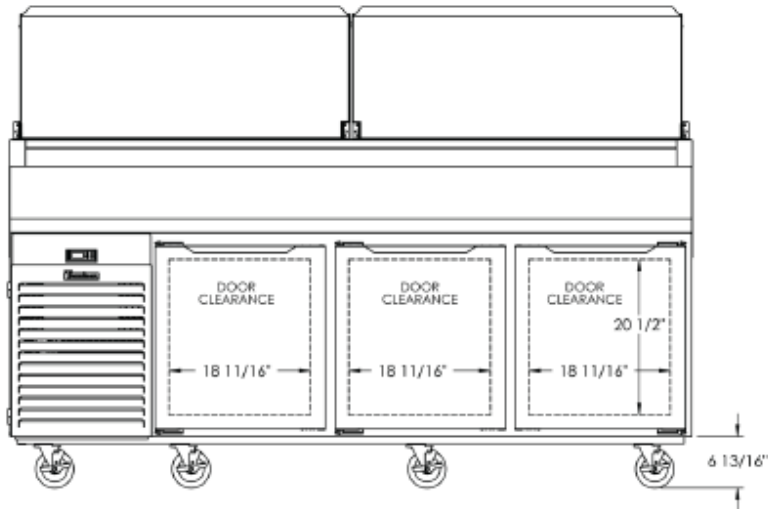


**Fig. 1.7.3b**  
Side View of 72" Cabinets

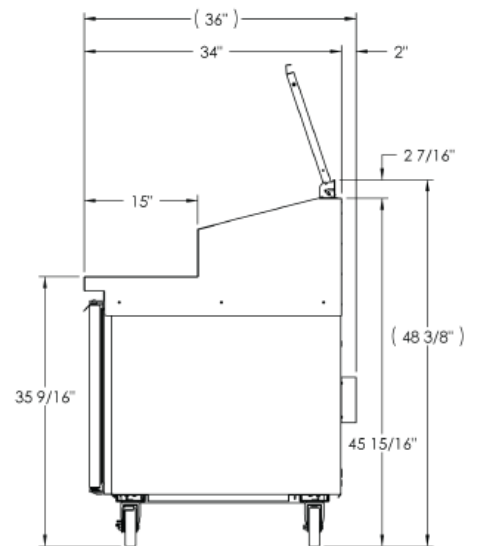


**Fig. 1.7.3c**  
Top View of 72" Cabinets

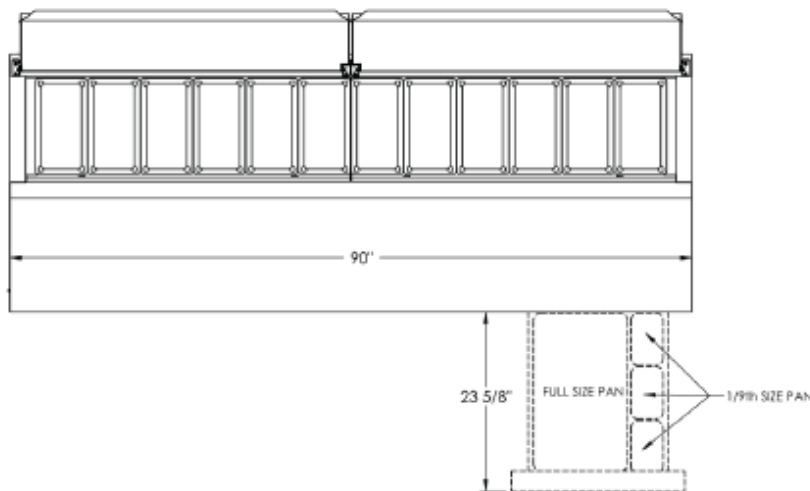
## 1.7.4 Prep Table 90" Specifications



**Fig. 1.7.4a**  
Front View of 90" Cabinets

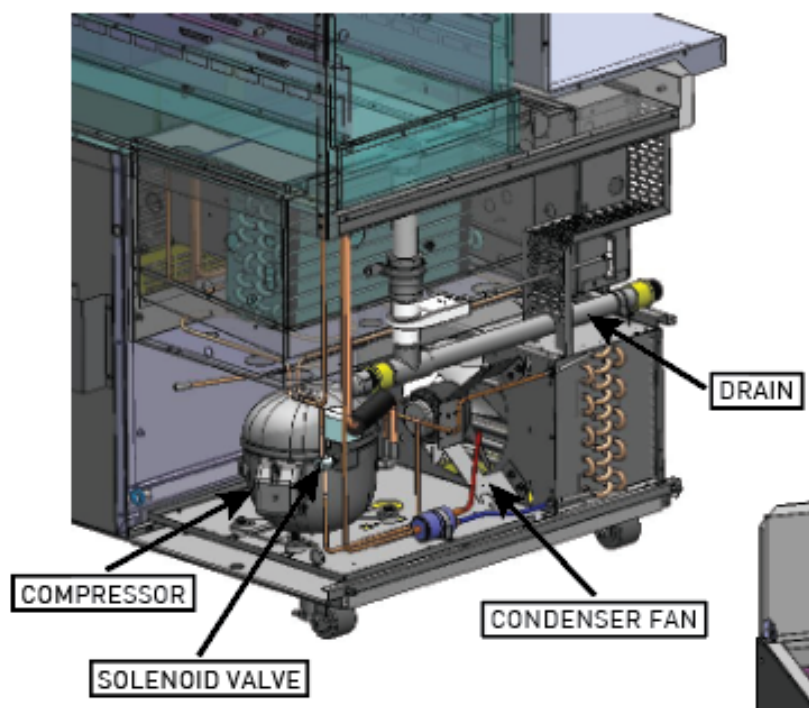


**Fig. 1.7.4b**  
Side View of 90" Cabinets

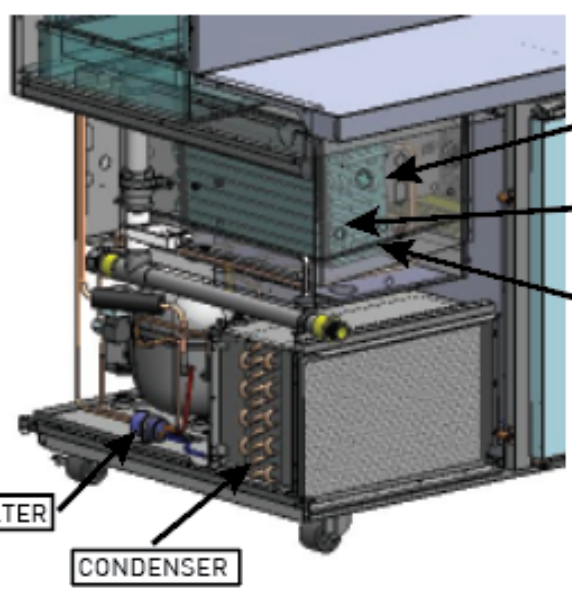
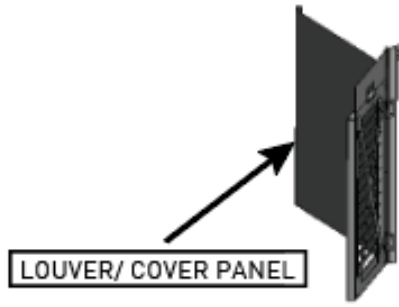
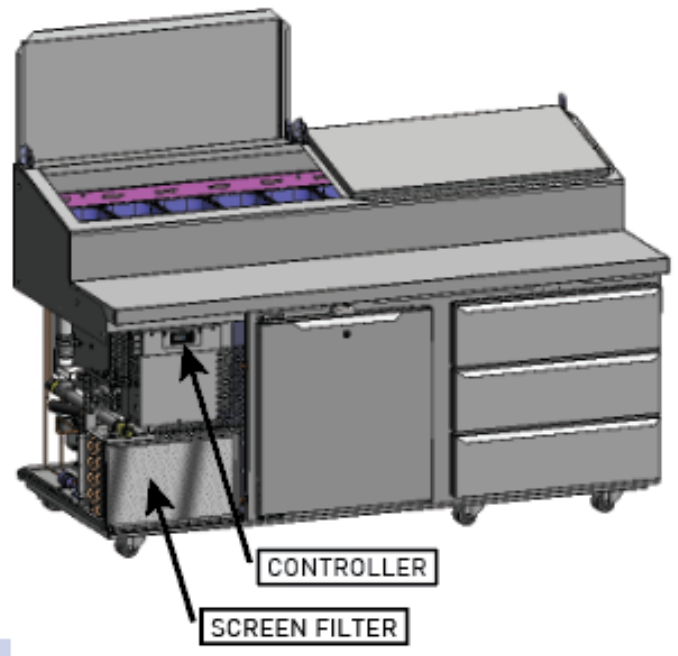


**Fig. 1.7.4c**  
Top View of 90" Cabinets

BACK CORNER VIEW



FRONT UNIT VIEW



- EVAPORATOR FAN - BEHIND EVAPORATOR
- TXV - BEHIND EVAPORATOR
- EVAPORATOR

- DRIER FILTER
- CONDENSER

FRONT CORNER VIEW

## 2. Preventive Maintenance

This section is to inform the recommended preventive maintenance (PM) procedures. Depending on application, PM schedule may vary.

### 2.1 Inspect & Clean Unit

<b>Why</b>	Sanitation & prolong cabinet life	
<b>Frequency</b>	Daily	
<b>Time required</b>	3 minutes to prepare	3 minutes to complete
<b>Preparation</b>	Have a soft cloth. Baking soda & water mixed to a 1 TBSP (15mL) baking soda to 1 pint (473.2mL) water ratio.	
<b>Cleaning</b>	Apply with a dampened cloth, wipe in the direction of the metal grain. (Avoid the use of strong detergents and gritty, abrasive cleaners as they may tend to mar and scratch the surface. Do NOT use cleansers containing chlorine; this may promote corrosion of the stainless steel.)	
<b>Inspection</b>	Visually inspect the unit for signs of wear that may require repair.	

Table 2.1  
Cleaning PM Procedure

### 2.2 Inspect & Clean Door Gasket

<b>Why</b>	Long reliable service life
<b>Frequency</b>	Every 3 months
<b>Time required</b>	10 minutes to complete
<b>Inspection</b>	Open cabinet door(s) to inspect gasket. Pull gasket with hand & visually inspect gasket for tears, dirt, mold or wear. Clean with mild soap & water. <b>Do NOT use cleaners containing chlorine or chlorides.</b> Replace as needed. <a href="#">341-60197-00</a> - Half-Height Gasket

Table 2.2  
Door Gasket Cleaning PM Procedure

### 2.3 Clean Condenser Coil

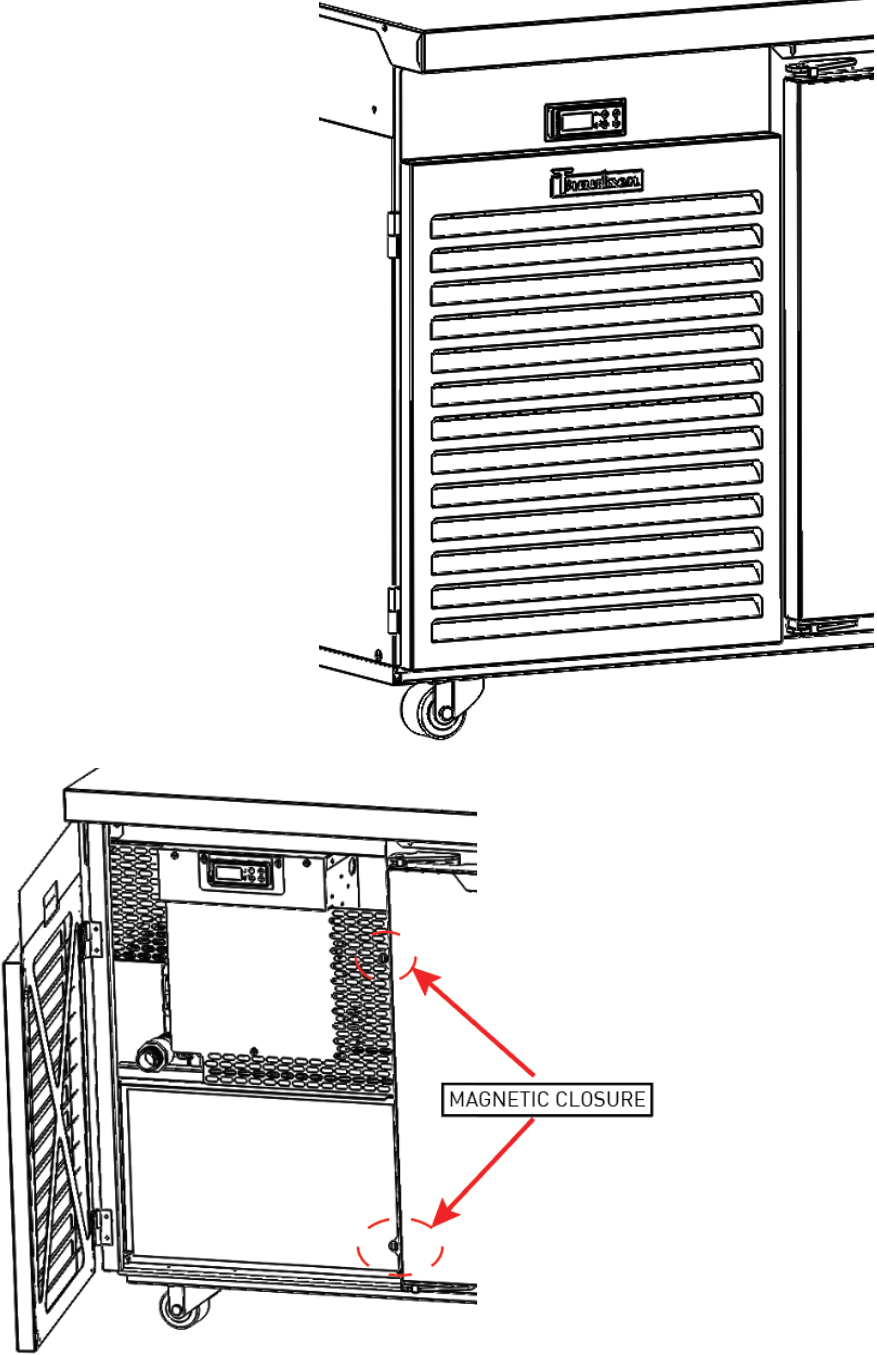
**⚠ WARNING** Disconnect electrical power supply before cleaning any parts of the unit.

<b>Why</b>	Long reliable service life, extended compressor life	
<b>Frequency</b>	Every 3 months	
<b>Time required</b>	5 minutes to prepare	15 minutes to complete

Table 2.3a  
Condenser Cleaning PM Procedure

#### INSPECTING EVAPORATOR COIL DRAIN PAN & DRAIN

Clear out any debris. Spray water on coil to ensure drain pan is flowing out of the drain.

<p style="text-align: center;"><b>Preparation</b></p>	 <p>To clean the condenser, first disconnect electrical power to the cabinet and swing outward the front louver assembly. The louver is latched magnetically.</p>
<p style="text-align: center;"><b>Cleaning</b></p>	<p>Use a soft bristle brush to remove any dirt, lint or dust from the finned condenser coil, around the compressor and other cooling system parts as indicated. Be sure to brush in the direction of the fins to prevent damage. If significant dirt is clogging the condenser fins, use compressed air to blow this clear. When finished, reverse the louver removal process as instructed above. <b>Compressor warranty claims will not be paid for units with dirty condensers.</b></p>

**Table 2.3b**  
**Condenser Cleaning PM Procedure**

## 3. Doors & Hardware

### 3.1 Hinges

#### 3.1.1 Removing the Doors & Hardware

To fit through narrow (less than 35") doorways, it may be necessary to remove the door(s), and/or hinges. To remove any solid door, begin by removing the safety screw at the bottom of the top hinge which secures the door in place. Remove this with a #2 Phillips screwdriver and the door can then be lifted off the hinges. After removing the door, it may be necessary to remove the hinge assembly and hardware from the door itself. If it is necessary to remove the hinge hardware from the cabinet, begin by removing the (3) Phillips-head screws which hold it in place. Set these components aside for later reassembly. Pay special attention not to lose the door switch actuator button.

The lock keeper may also require removal to reduce the overall cabinet depth to 32".

First remove the lock keeper strike plate by removing the (2) Phillips-head screws which secure it in place- exposing the adjustment screws. Then remove both adjustment screws from the mounting plate. To reinstall the door and/or hinges, please reverse the appropriate sections of the preceding procedure.

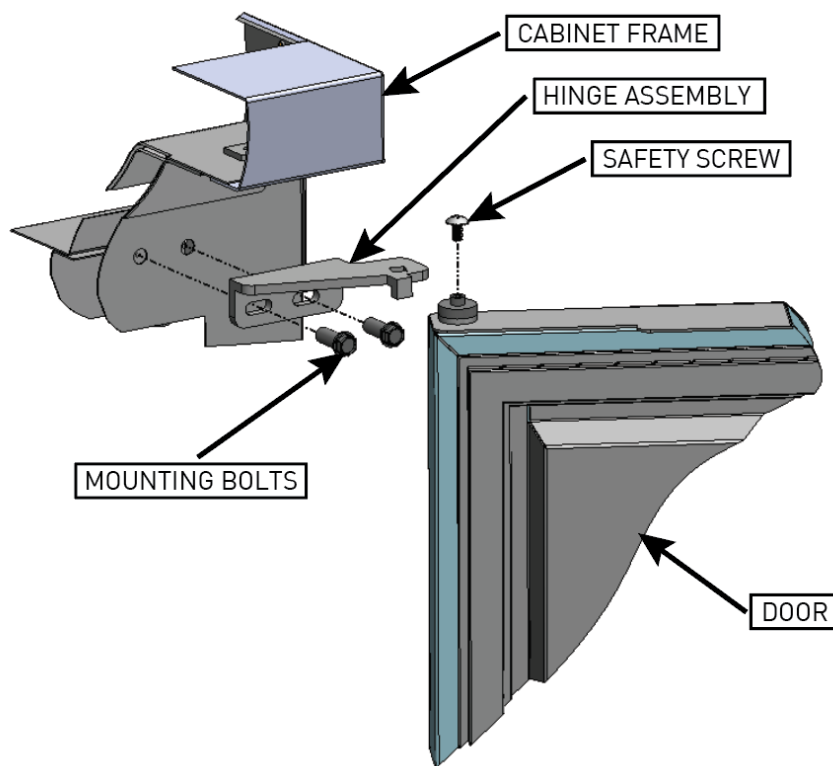


Fig. 3.1.1a  
Hinge Assembly

**WARNING**  
WHEN REMOVING DOORS ENSURE THEY ARE SET ASIDE IN A SECURE POSITION TO PREVENT FALL/SLIP THAT MAY CAUSE PERSONAL INJURY.

Fig. 3.1.1b  
Top Hinge Exploded View

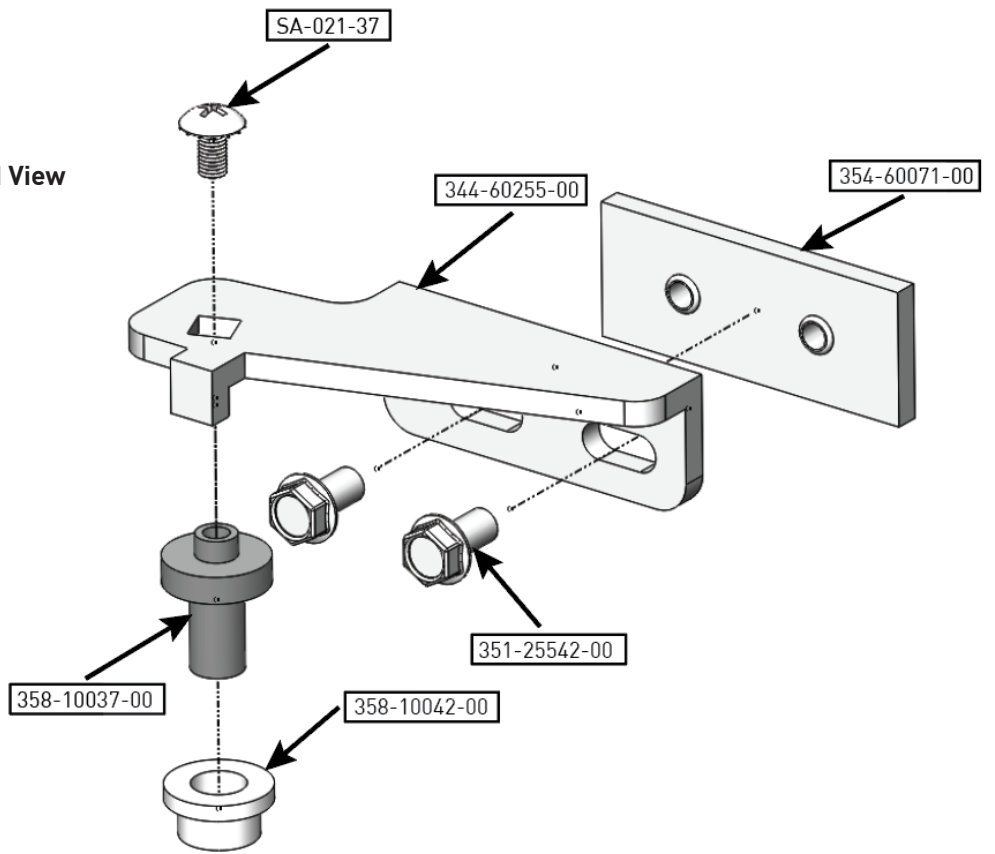
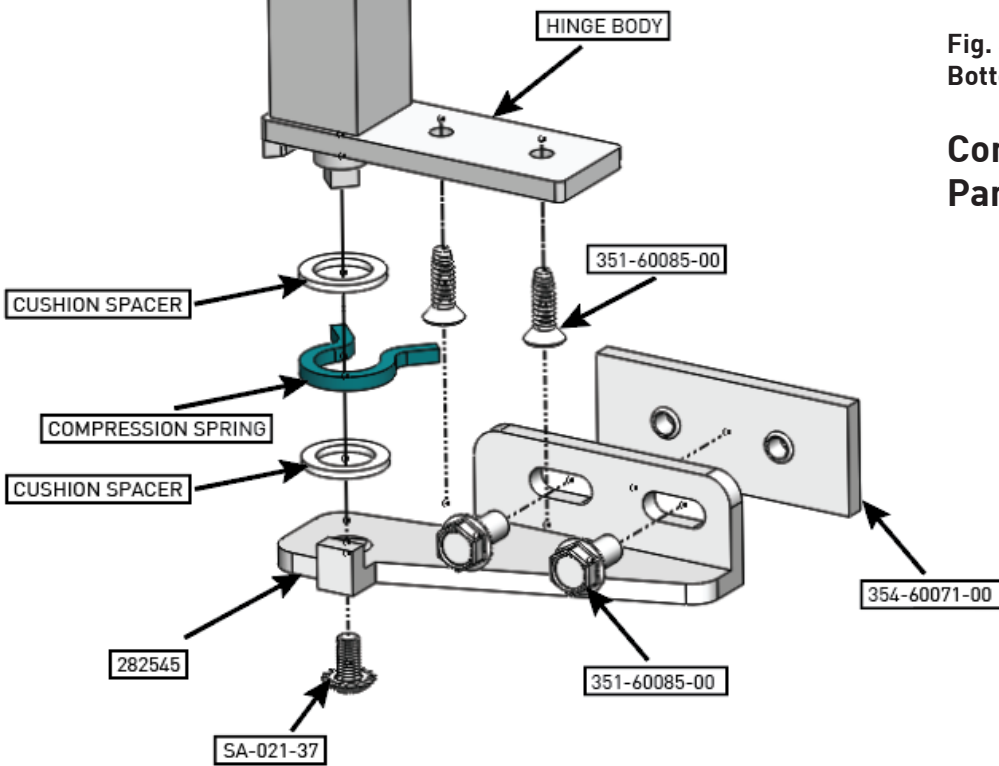


Fig. 3.1.1C  
Bottom Hinge Exploded View

Compact hinge assembly  
Part# **SER-60248-00**

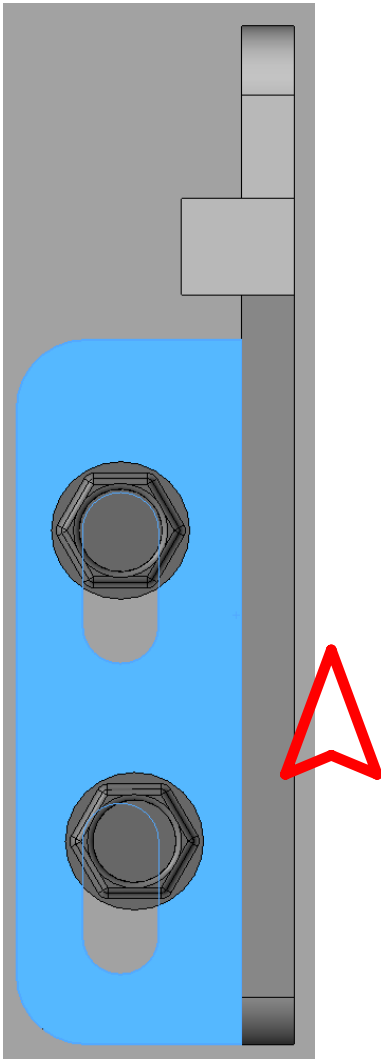


## 3.2 Adjustments

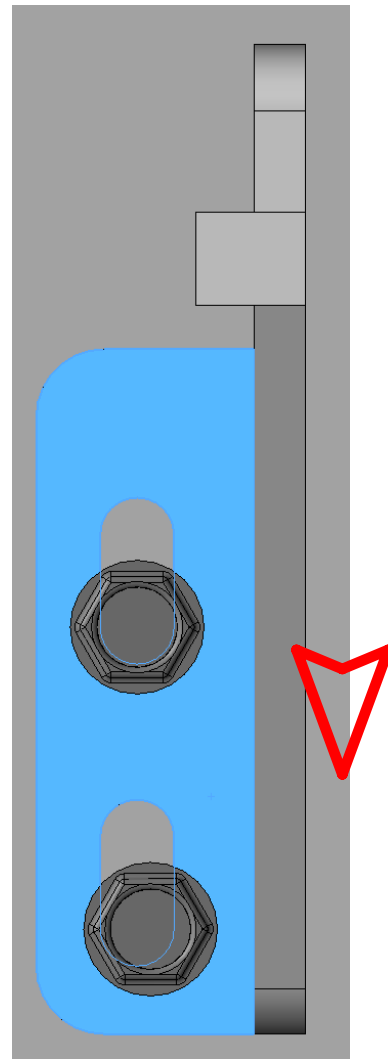
### Performing a Door Adjustment:

These instructions are intended to aid the technician in the field perform hinge adjustments and may not cover all situations that could arise. Final diagnosis of field-based equipment is the sole responsibility of the technician performing any work required.

1. Loosen the (2) bolts securing each hinge bracket to the exterior frame.
2. Shift door inward or outward centering door in frame for proper seal of gasket.
3. Position the adjusting plate to the desired fit, tighten the screws.



**Fig. 3.2a**  
**Door Adjustment Inward**



**Fig. 3.2b**  
**Door Adjustment Outward**

### 3.3 EZ- Clean Gaskets

#### Door Gasket Replacement:

Remove an old gasket by grasping it firmly by one corner and pull it out. Install the new gasket by inserting all (4) corners first. After the corners are properly inserted, work your way towards the center from both ends- pushing the dart into the retainer until the gasket is completely seated in place. Check for a proper seal all the way around the door.

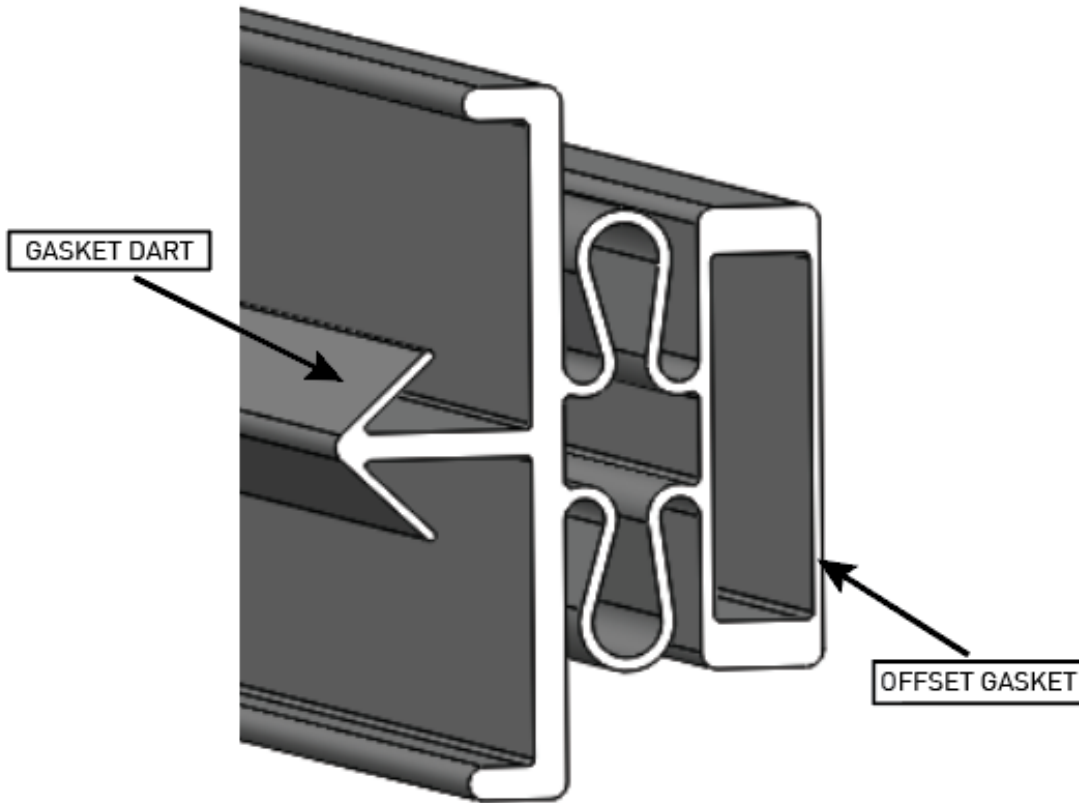


Fig. 3.3  
Gasket Section View

Description	Part Number
Half-Height Door Gasket (22.134" x 24.79")	<a href="#">341-60197-00</a>

Table 3.3  
Door Gasket Part Number

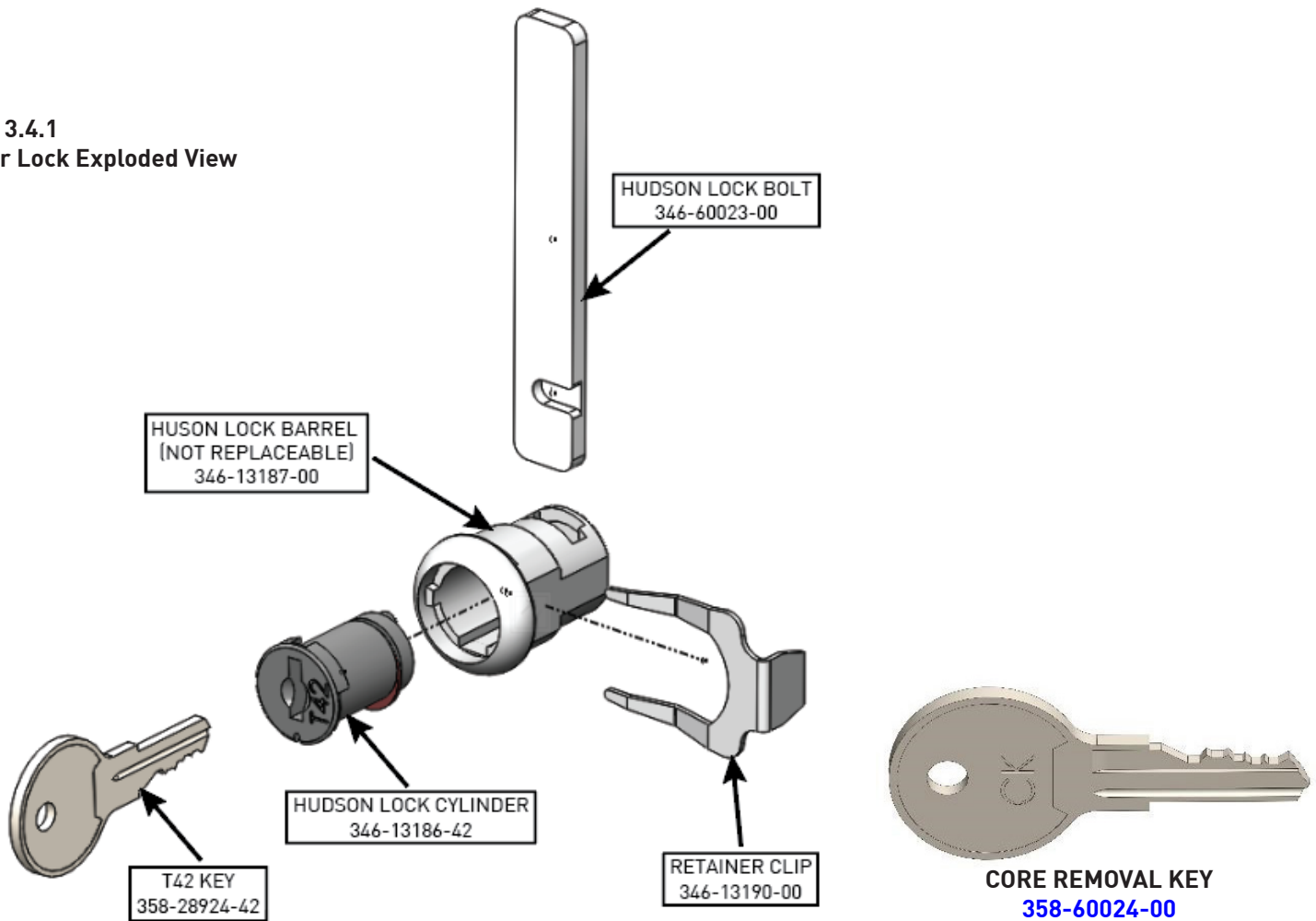


\*\*\* "Scan for Gasket Installation & Service Videos!" \*\*\*

## 3.4 Locks

### 3.4.1 Door Lock Assembly Exploded View

Fig. 3.4.1  
Door Lock Exploded View



**NOTE:** Core removal key should only be used to remove door lock assembly. A damaged Hudson lock barrel requires door replacement.

**Table 3.4.1a**  
**Door Lock Service Kit Part Numbers**

#### **Wear And Tear:**

Overtime, the lock and key cylinder can become worn out due to excessive use, environmental exposure (such as moisture, dust, or grease) or simply because of age. This can cause difficulty in turning the key and in some cases damaging the cylinder necessitating a replacement.

### 3.4.2 Door Lock Replacement Instructions

#### Disassembly of Lock:

To remove the lock cylinder for replacement, insert the core removal key into the lock- causing the spline to lower so the lock cylinder can be removed. Move the key up & down, then pull backwards; the core key will pull the lock cylinder along with it. The lock bolt is now free to slide out of the lock barrel for replacement (if applicable).

#### Assembly of Lock:

Insert the lock bolt into the lock barrel until the groove in the bolt is approximately in the locked position. Insert the core removal key into the lock cylinder (causing the spline to lower) and insert the lock cylinder into the lock barrel (**NOTE: Lock stud must be lined up with lock bolt groove**). Use one hand to firmly hold the lock cylinder in place, then remove the core key with the other (causing spline to rise & securing lock cylinder).

**NOTE:** Lock barrel is assembled to the door during production at the factory. A damaged lock barrel requires door replacement. Core removal key should only be used for lock replacement. Use of core removal key to lock & unlock the door will cause the lock cylinder to fall out.

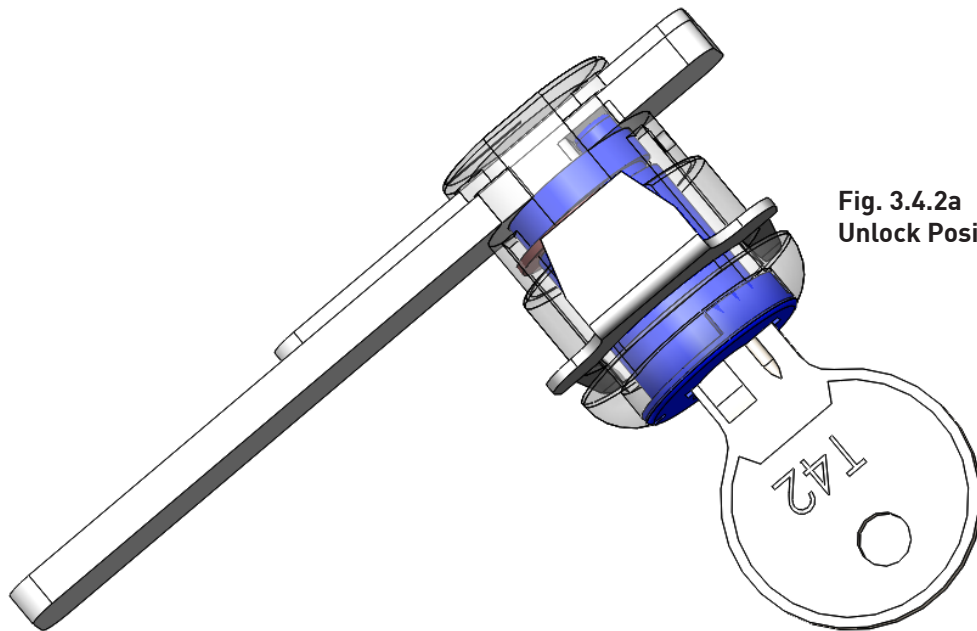


Fig. 3.4.2a  
Unlock Position

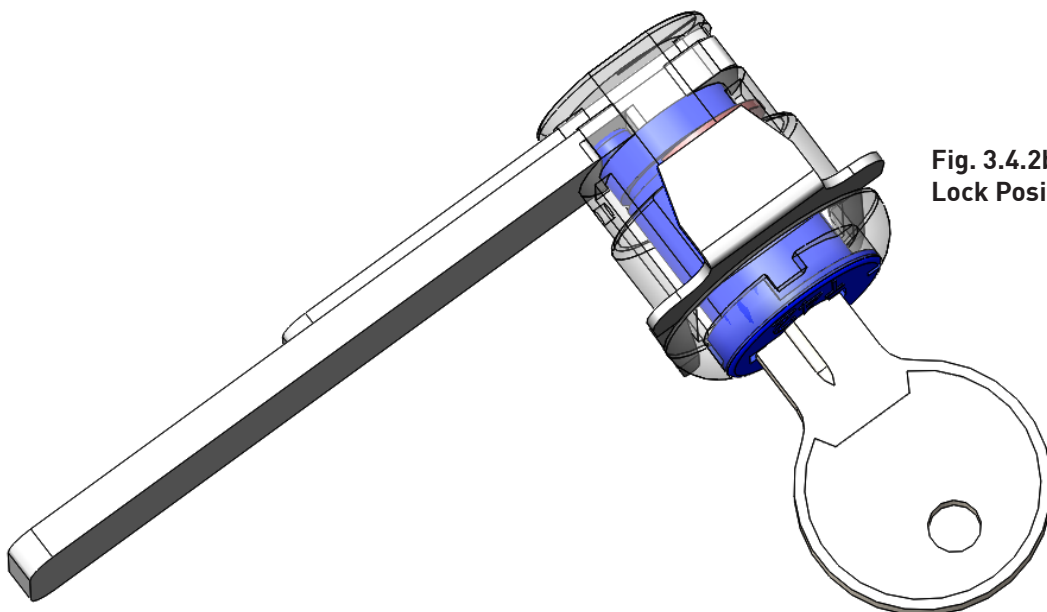
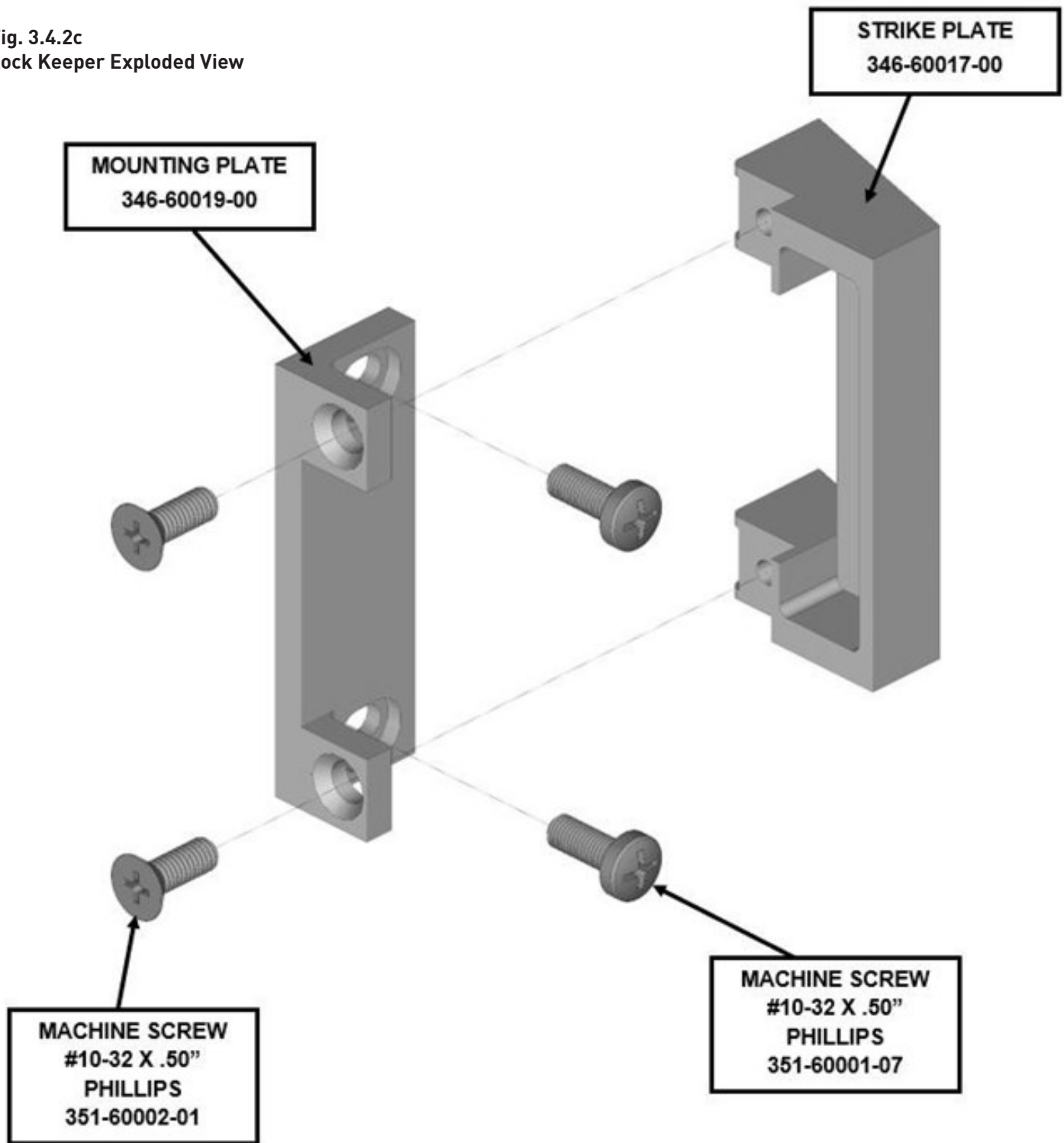


Fig. 3.4.2b  
Lock Position

Fig. 3.4.2c  
Lock Keeper Exploded View



### Adjusting the Lock Keeper:

1. Remove the (2) machine screws holding the strike plate to the mounting plate using a #2 Phillips screwdriver.
2. Remove the strike plate.
3. Loosen the (2) machine screws holding the mounting plate to the cabinet.
4. Adjust the mounting plate (left or right) until:
  - A. The lock keeper does not interfere with the door opening or closing.
  - B. The lock bolt extends far enough in the locked position to be stopped by the strike plate, locking the door.



**ADJUSTED INWARD**



**ADJUSTED OUTWARD**

**Fig. 3.4.2d**  
**Lock Keeper Adjustment**

### Proper Lock Keeper Adjustments

Ensuring the lock keeper is properly adjusted is crucial for maintaining secure closure of the unit's doors. A misaligned lock keeper can result in doors that fail to lock, which can compromise the internal temperature and security of the unit. Regularly inspecting and adjusting the lock keeper can help prevent such issues.

Key Considerations:

**Alignment:** The lock keeper must be precisely aligned with the lock bolt to ensure a secure lock. Misalignment can cause difficulty in locking the door or result in a loose fit.

**Security:** A properly adjusted lock keeper ensures that the door locks tightly, preventing unauthorized access and minimizing temperature fluctuations caused by air leaks.

**Wear and Tear:** Over time, usage, and normal wear can cause the lock keeper to shift slightly out of alignment. Regular adjustments prevent potential locking issues.

## 4. Controls

### 4.1 Understanding the Display

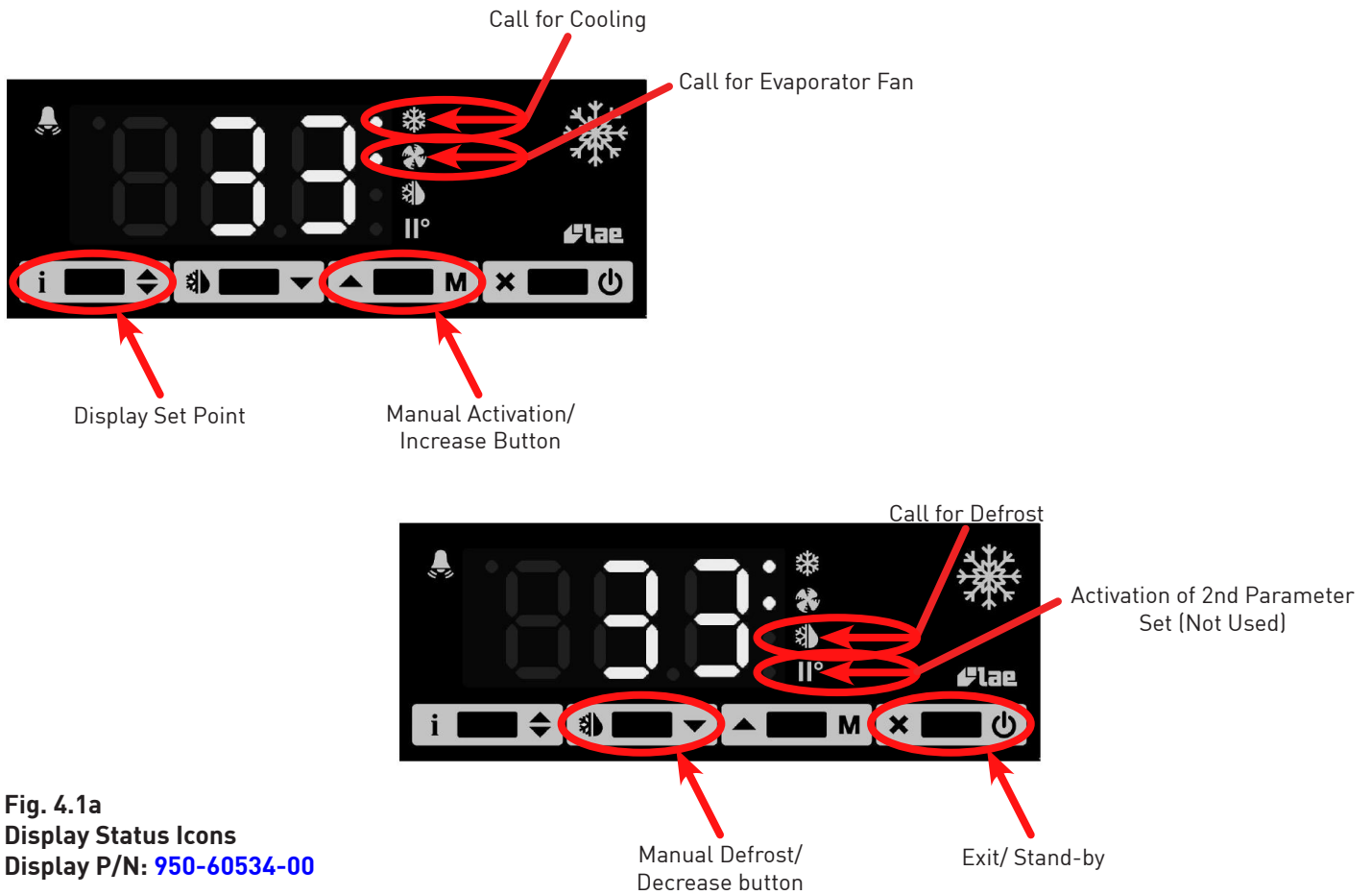


Fig. 4.1a  
Display Status Icons  
Display P/N: [950-60534-00](#)

#### Display Characters:

dEF Defrost In Progress	H <sup>P</sup> Condenser High Pressure Alarm
dFF Controller In Stand-by	H <sup>H</sup> High Temp Alarm
dL Condenser Clean Warning	L <sup>O</sup> Low Temp Alarm
d <sub>DO</sub> Door Open Alarm	E <sub>1</sub> Cabinet Sensor Failure
d <sub>CO</sub> Condenser Over temp	E <sub>2</sub> Coil Sensor Failure

## 4.2 Control Cover Removal & Components

Open bottom louver & rotate louver out of the way. Remove (3) screws of screen cover placing cover to the side. Remove (2) screws attaching faceplate to control box. Disconnect cable from the back of the controller. Lastly, squeeze the (4) tabs holding on the back side of the display & push outward to remove the display. See figure 4.12.1.

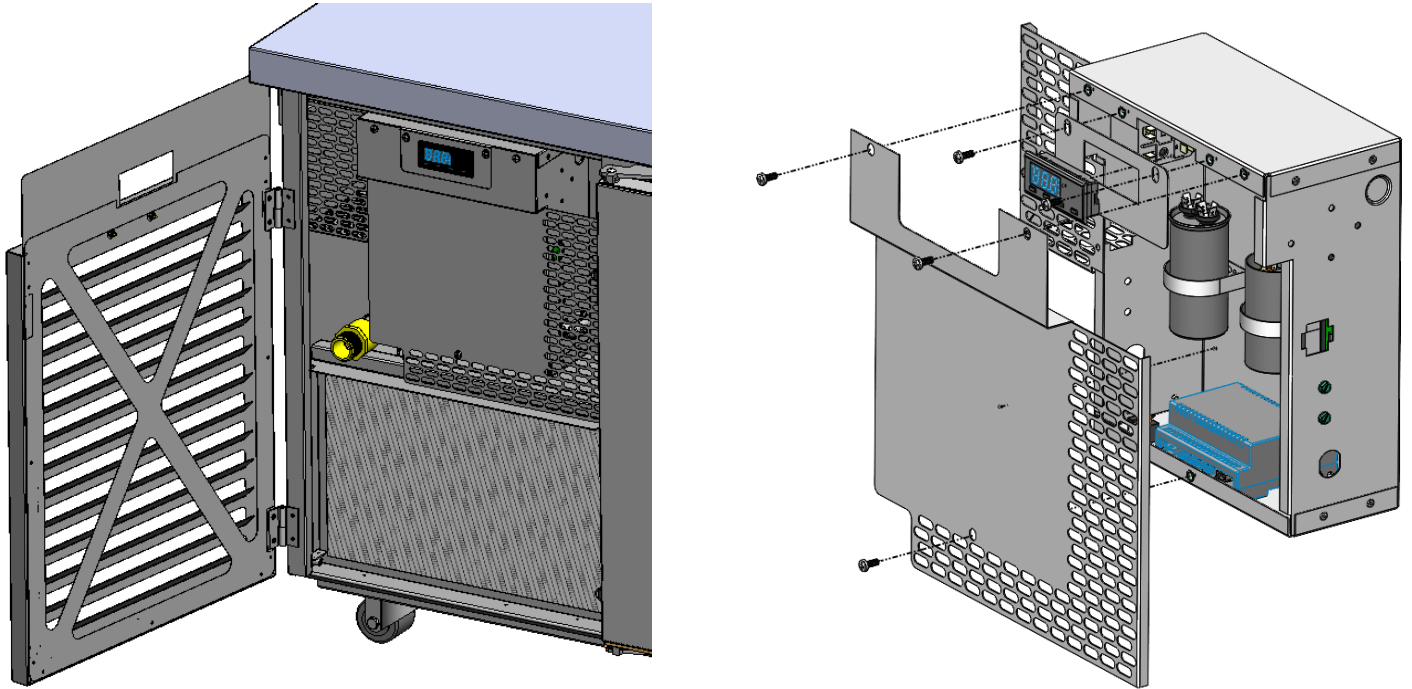


Fig. 4.2 Display Removal  
Display P/N: [950-60534-00](#)

### 4.2.1 Installing the Display

Line up the display with the cutout on the cabinet. Firmly press the (4) outside corners (do not press the center) of the controller into the cabinet until the (4) tabs click into place. Make sure to reconnect the cable to the display.

**NOTE:** Do not press on the center of the display during installation to avoid causing damage.

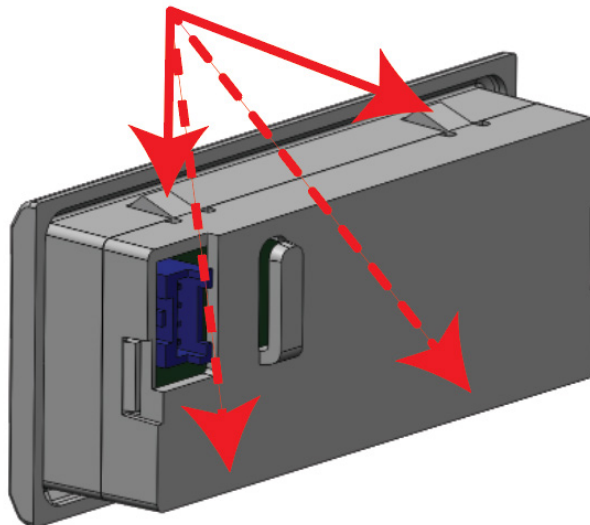


Fig. 4.2.1 Display Install

#### 4.2.2 Accessing the Power Module (TRL-002 Control Board)

Use a #2 Phillips screwdriver to remove (3) screws (see figure 4.12.3) and lift on bracket.

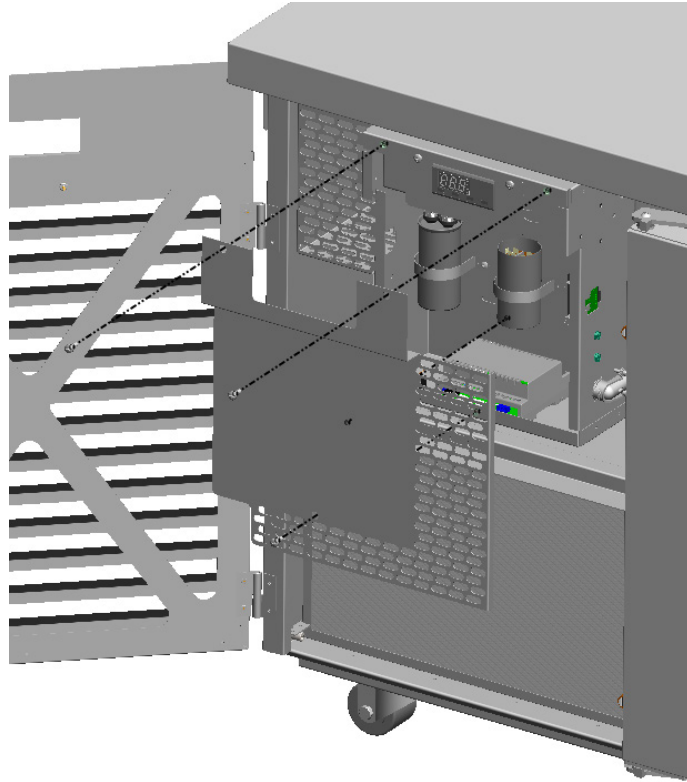


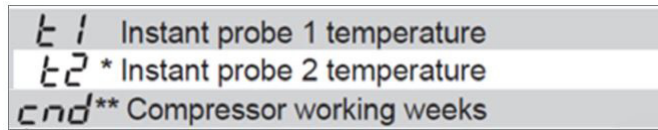
Fig. 4.2.2 Power Module Access (Control Board)

### 4.3 Control basics

Your new Milk Cooler is equipped with a digital control, which precisely regulates operation. It is supplied from the factory completely ready for use and is located next to the refrigeration system underneath the cover.

### 4.4 Information Menu

The information available in this menu is:



\* Displayed only if enabled (see Configuration Parameters)

\*\* Displayed only if ACC → 0

#### Access to menu and information displayed:

- Press and immediately release button **i**.
- With button **▼** or **▲** select the data to be displayed.
- Press button **i** to display value.
- To exit from the menu, press button **✕** or wait for 10 seconds.

#### Initiate Stand-By:

Keeping the button **⏻** pressed for 3 seconds allows the controller to be put on a standby or output control to be resumed (with **SB=YES** only).

#### Locking the Keypad:

The keypad lock avoids undesired, potentially dangerous operations, which might be attempted when the controller is operating in a public place. In the INFO menu, set parameter **LOC** = YES to inhibit all functions of the buttons. To resume normal operation of keypad, adjust setting so that **LOC** = NO.

### 4.5 Adjusting Cabinet Setpoint

#### Setpoint display and modification:

Adjust Setpoint:

- Press button for **i** second to display setpoint value
- Keeping the **i** button pressed use **▼** or **▲** buttons to set the desired value
- When **i** button is released the new value is stored
- Press button **i** for at least a half second to display the setpoint value.
- While keeping the **i** button pressed, use button **▼** or **▲** to set the desired value (adjustment is within the minimum **SPL** and the maximum **SPH** limit).
- When button **i** is released, the new value is stored.

### 4.6 Initiating a Defrost

#### Automatic defrost:

Defrost starts automatically as soon as the time set with parameter **DFT** has elapsed.

- Timed defrost: With **DFM** = TIM defrosts take place at regular intervals when the timer reaches the value of **DFT**. For example, with **DFM** = TIM and **DFT** = 36, a defrost will take place every 6 hours.
- Optimized defrost: With **DFM** = FRO the timer is only increased when the conditions occur for frost to form on the evaporator, until the time set with parameter **DFT** is matched. If the evaporator works at 0°F, defrost frequency depends on the thermal load and climatic conditions. With setpoints much lower than 0°F, defrost frequency mainly depends on the milk cooler operating time.
- Defrost time count backup: At the power-up, if **DFB** = YES, the defrost timer resumes the time count from where it was left off before the power interruption. Vice versa, with **DFB** = NO, the time count re-starts from 0. In stand-by, the accumulated time count is frozen.

#### Manual or remote defrost start:

It's possible to manually start a defrost, by pressing button **⏻** for 2 seconds.

**Defrost type**. Once defrost has started, Compressor and Defrost outputs are controlled according to parameter **DTY**. If **FID** = YES, the evaporator fans are active during defrost.

Defrost termination. The actual defrost duration is influenced by a series of parameters.

- Time termination: **T2** = NO and **T3** different from 2EU: the evaporator temperature is not monitored and defrost will last as long as time **DTO**.
- Temperature monitoring of one evaporator: **T2** = YES and **T3** different from 2EU. In this case, if the sensor **T2** measures the temperature **DLI** before the time **DTO** elapses, defrost will be terminated in advance.











#### Resuming thermostatic cycle:

When defrost is over, if **DRN** is greater than 0, all outputs will remain off for **DRN** minutes, in order for the ice to melt completely and the resulting water to drain. Moreover, if probe **T2** is active (**T2** = YES), the fans will re-start when the evaporator gets to a temperature lower than **FDD**; Vice versa, if probe **T2** is not active (**T2** = NO) or after defrost has come to an end, such condition does not occur by end of the time **FTO**, after **FTO** minutes have elapsed the fans will be switched on anyway.

Caution: if **DFM** = NON or **C-H** = HEA all defrost functions are inhibited; if **DFT** = 0, automatic defrost functions are excluded.

## 4.7 Configuration Parameters

### Parameter Configuration:

- To get access to the parameter configuration menu, press button  and  for 5 seconds.
- With button  or  select the parameter to be modified.
- Press button  to display the value.
- By keeping button  pressed, use button  or  to set the desired value.
- When button  is released, the newly programmed value is stored and the following parameter is displayed.
- To exit from the setup, press button  or wait for 30 seconds.

## 4.8 Technical Data

Power supply

TRL-002....W 100-240Vac ±10%, 50/60Hz, 3W

Relay output max loads (240Vac)

	TRL-002..S/T..-	TRL-002..Q/R..-
Compressor	16A resistive 12 FLA 48 RLA	12A resistive 12 FLA 48 RLA
Evap. Fan	16A resistive 4 FLA 12 RLA	"8A resistive 4 FLA 12 RLA"
Defrost	16A resistive 4 FLA 12	16A resistive 4 FLA 12 RLA
Auxiliary loads 1	7A resistive	7A resistive
Auxiliary loads 2	7A resistive	7A resistive

### Input

NTC 10KΩ@25°C LAE Part No. SN4...

### Measurement Range

←0.5 within the measurement range

### Operating Conditions

-10... +50°C; 15%...80% r.H.

### CE (Approvals and Reference Norms)

EN60730-1; EN60730-2-9; EN55022 (Class B); EN50082-1

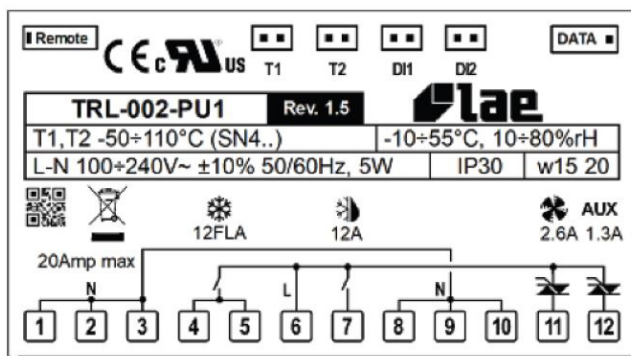


Fig. 4.8 Control Wiring Diagram

PAR	RANGE	DESCRIPTION
SPL	-58..SPH	Minimum limit for SP setting.
SPH	SPL...180°	Maximum limit for SP setting.
SP	SPL... SPH	Setpoint (value to be maintained in the room).
C-H	REF; HEA	Refrigerating (REF) or Heating (HEA) control mode.
HY0	1...10°	Thermostat OFF → ON differential.
HY1	0...10°	Thermostat ON → OFF differential.
CRT	0...30 min	Compressor rest time. The output is switched on again after CRT minutes have elapsed since the previous switchover. We recommend to set CRT=03 with HY0←-2.0°.
CT1	0...30 min	Compressor/Heater output run when probe T1 is faulty. With CT1=0 the output will always remain OFF.
CT2	0...30 min	"Compressor/Heater output stop when probe T1 is faulty. With CT2=0 and CT1→0 the output will always be ON. Example: CT1=4, CT2= 6: In case of probe T1 failure, the compressor will cycle 4 minutes ON and 6 minutes OFF."
DFM	NON; TIM; FRO CRN	"Defrost start mode <b>NON</b> : defrost function is disabled (the following parameter will be FCM). <b>TIM</b> : regular time defrost. <b>FRO</b> : the defrost time count is only increased when the conditions occur for frost to form on the evaporator (optimized time increase). <b>CRN</b> : defrost is based off of compressor run time (time is based off of DAT)."
DFT	0...250	Time interval among defrosts in x10 minutes. When this time has elapsed since the last defrost, a new defrost cycle is started. Each number is multiplied by 10 minutes. 0-250 indicates 0-2500 minutes.
DAT	"0...100 hours"	Frost accumulation timeout.
DFB	NO/YES	Defrost timer backup. With DFB=YES, after a power interruption, the timer resumes the count from where it was left off with ±30 min. approximation. With DFB=NO, after a power interruption, the defrost timer will re-start to count from zero.
DLI	-58...180°	Defrost end temperature.
DMD	0...30 min	Minimum defrost duration.
DTO	1...120 min	Maximum defrost duration.
DTY	OFF; ELE; GAS	"Defrost type OFF: off cycle defrost (Compressor and Heater OFF). ELE: electric defrost (Compressor OFF and Heater ON). GAS: hot gas defrost (Compressor and Heater ON)."
DSO	OFF; LO; HI	"Defrost start optimization OFF : no optimization. LO : defrost waits until the compressor cut-out. HI : defrost waits until the compressor cut-in."
SOD	0...30 min	Start optimization delay.
DPD	0...240 sec	Evaporator pump down. At the beginning of defrost, defrost outputs (determined by DTY) are OFF for DPD seconds.
DRN	0...30 min	Pause after defrost (evaporator drain down time).
DDM	"RT; LT; SP; DEF"	"Defrost display mode. During defrost the display will show: <b>RT</b> : the real temperature; <b>LT</b> : the last temperature before defrost; <b>SP</b> : the current setpoint value; <b>DEF</b> : "dEF"."

PAR	RANGE	DESCRIPTION
DDY	0...60 min	Display delay. The display shows the information selected with parameter DDM during defrost and for DDY minutes after defrost termination.
FID	NO/YES	Fans active during defrost.
FDD	-58...180°	Evaporator fan re-start temperature after defrost.
FTO	0...120 min	Maximum evaporator fan stop after defrost.
FCM	NON; TMP; TIM	“Fan mode during thermostatic control. <b>NON</b> : The fans remain ON all the time; <b>TMP</b> : Temperature-based control. The fans are ON when the compressor is ON. When the compressor is turned OFF, the fans remain ON as long as the temperature difference $T_e - T_a$ is greater than FDT. The fans are turned ON again with FDH differential. ( $T_e$ = Evaporator temperature, $T_a$ = Air temperature); <b>TIM</b> : Timed-based control. The fans are ON when the compressor is ON. When the compressor is OFF, the fans switch ON and OFF according to parameters FT1, FT2, FT3”
FDT	-12...0°	Evaporator-Air temperature difference for the fans to turn OFF after the compressor has stopped.
FDH	1...12°	Temperature differential for fan re-start.
		Example: FDT = -1, FDH=3. In this case, after the compressor has stopped, the fans are OFF when $T_e \rightarrow T_a - 1$ (FDT), whereas the fans are ON when $T_e \leftarrow T_a - 4$ (FDT-FDH).
FT1	0...180 sec	Fan stop delay after compressor/heater stop. See Fig. 2
FT2	0...180	Timed fan stop in x10 seconds. With FT2=0 the fans remain on all the time.
FT3	0...180	Timed fan run in x10 seconds. With FT3=0, and FT2 $\rightarrow$ 0, the fans remain off all the time.
ATM	NON; ABS; REL	“Alarm threshold management. <b>NON</b> : all temperature alarms are inhibited (the following parameter will be ACC). <b>ABS</b> : the values programmed in ALA and AHA represent the real alarm thresholds. <b>REL</b> : the alarm threshold is obtained by the sum of setpoint, thermostat differential and ALR/ AHR.”
ALA	-58... 180°	Low temperature alarm threshold.
AHA	-58... 180°	High temperature alarm threshold.
ALR	-12... 0°	Low temperature alarm differential. With ALR=0 the low temperature alarm is excluded.
AHR	0... 12°	High temperature alarm differential. With AHR=0 the high temperature alarm is excluded.
ATI	T1; T2; T3	Probe used for temperature alarm detection.
ATD	0... 120 min	Delay before alarm temperature warning.
ACC	0...52 weeks	Condenser periodic cleaning. When the compressor operation time, expressed in weeks, matches the ACC value programmed, “CL” flashes in the display. With ACC=0 the condenser cleaning warning is disabled and CND disappears from Info Menu.
IISM	NON; MAN; ECO; DI	“Switchover mode to second parameter set <b>NON</b> : inhibition to use the second parameter group (the following parameter will be SB). <b>MAN</b> : button switches the two parameter groups over. <b>ECO</b> : automatic switchover to the second parameter group, when ECO conditions are detected. <b>DI</b> : switchover to the second parameter group when DIx input is on.”
IISL	-58... IISH	Minimum limit for IISP setting.

PAR	NGE	ON
IISH	IISL... 180°	Maximum limit for IISP setting.
IISP	IISL... IISH	Setpoint in mode 2.
IIH0	1... 10°	Thermostat OFF-->ON differential in mode 2.
IIH1	0... 10°	Thermostat ON-->OFF differential in mode 2.
IIDF	0...250	Time interval among defrosts in mode 2 in x10 minutes.
IIFC	"NON; TMP; TIM"	Fan control in mode 2. See FCM.
ECS	1...5	Controller sensitivity for the automatic switchover from Group I to Group II (1=minimum, 5=maximum).
ECS	1...5	Controller sensitivity for the automatic switchover.
EPT	0...240 min	Eco pull-down time. Only with IISM=ECO. Group I parameters are used in regulation for at least EPT minutes. See Fig.3
SB	NO/YES	Stand-by button enabling.
DSM	NON; ALR; STP	"Door switch input mode: <b>NON</b> : door switch inhibited <b>ALR</b> : when DIx=DOR and the digital input is on, an alarm is generated after ADO minutes <b>STP</b> : when DIx=DOR and the digital input is on, in addition to the alarm, the fans are immediately stopped and the compressor is stopped after CSD minutes."
DAD	0...30 min	Delay before door open alarm warning.
CSD	0...30 min	Compressor/heater stop delay after door has been opened.
D10	NON; DOR; ALR; IISM; RDS	"DI1 digital input operation <b>NON</b> : digital input 1 not active. <b>DOR</b> : door input. <b>ALR</b> : when the input is on, an alarm is generated (if AHM=STP, the compressor is stopped and the defrosts are suspended). <b>IISM</b> : when the input is on, the controller will use group 2 parameters. <b>RDS</b> : when the input is on, a defrost is started (remote control)."
D1A	OPN; CLS.	"DI1 digital input activation. <b>OPN</b> : on open <b>CLS</b> : on close"
D20	See D10	DI2 digital input operation. See D10.
D2A	OPN; CLS.	"DI2 digital input activation. <b>OPN</b> : on open <b>CLS</b> : on close"
PSL	-58...158	Minimum setpoint adjusted via potentiometer.
PSR	0...15	Range of setpoint adjusted via potentiometer.
LSM	"NON; MAN; ECO; DI1; DI2; DI3."	"Light control mode <b>NON</b> : light output not controlled. <b>MAN</b> : light output controlled through button (if OAx=LGT). <b>ECO</b> : lights activated/deactivated following the ECO state. <b>DIx</b> : lights activated/deactivated following the DIx state."
LSA	OPN; CLS	"Light activation (only with LSM=ECO or LSM=DIx). <b>OPN</b> : lights on with DIx open or ECO mode deactivated. <b>CLS</b> : lights on with DIx closed or ECO mode activated."
OT1	0...600 sec	Activation time of OA1

PAR	RANGE	DESCRIPTION
OT2	0...600 sec	Pause between OA1 activation
OA1	“NON; LGT; 0-1; 2CU; 2EU; ALO; ALC”	“AUX 1 output operation NON : output disabled (always off). LGT : output enabled for light control. 0-1 : the relay contacts follow the on/standby state of controller. 2CU : output programmed for the control of an auxiliary compressor. 2EU : output enabled for the control of the electrical defrost of a second evaporator. ALO : contacts open when an alarm condition occurs. ALC : contacts make when an alarm condition occurs.”
2CD	0...120 sec	Auxiliary compressor start delay. If OAx=2CU the auxiliary output is switched on with a delay of 2CD seconds after the main compressor has cut-in. Both compressors are turned off at the same time.
OS1	-12.5..12.5°	Probe T1 offset.
T2	NO/YES	Probe T2 enabling (evaporator).
OS2	-12.5..12.5°	Probe T2 offset.
T3	NON; DSP; CND; 2EU	“Auxiliary probe T3 operation <b>NON</b> : probe T3 not fitted. <b>DSP</b> : temperature T3 to be displayed. <b>CND</b> : condenser temperature measurement. <b>2EU</b> : second evaporator temperature measurement.”
OS3	-12.5..12.5°	Probe 3 offset.
AHM	NON; ALR; STP;	“Operation in case of high condenser alarm <b>NON</b> : high condenser alarm inhibited. <b>ALR</b> : in case of alarm, “HC” flashes in the display and the buzzer is switched on. <b>STP</b> : in addition to the alarm symbols displayed, the compressor is stopped and defrosts are suspended.”
AHT	-50...110°	Condensation temperature alarm (referred to T3 probe).
TLD	1...30 min	Delay for minimum temperature (TLO) and maximum temperature (THI) logging.
TDS	T1; 1-2; T3	“Selects the temperature probe to be displayed. <b>T1</b> : probe T1 <b>1-2</b> : the AVG-weighted average between T1 and T2 <b>T3</b> : probe T3”
AVG	0...100%	“The relative weight of T2 on T1 (if TDS = 1-2) Example 1: T1 = -5°, T2 = -20°, AVG = 100%. The displayed temperature will be -20° (T1 has no effect) Example 2: T1 = -5°, T2 = -20°, AVG = 60%. The displayed temperature will be -14.”
SCL	“1°C; 2°C; °F”	“Readout scale. <b>1°C</b> : measuring range -50...110°C (0.1°C resolution within -9.9 ÷ 19.9°C interval, <b>1°C</b> outside) <b>2°C</b> : measuring range -50 ... 110°C <b>°F</b> : measuring range -55 ... 180°F”
SIM	0...100	Display slowdown.
ADR	1...255	TRL-002 address for PC communication.
NPR	0...1	Setup programmed.
STT	0...255	Setup traceability.

## 4.9 Temperature Reading Calibration

This service manual provides instructions for accurately testing temperature sensors within an Traulsen TS undercounter refrigeration system by immersing them in an ice bath at precisely 32°F.

### Ice Bath Preparation:

Fill a suitable container with an 80% ice to 20% water ratio to create an ice bath with a consistent temperature of 32°F.

### **Dipping the Sensor Bulb:**

Locate the bulb of the temperature sensor that requires testing.

Submerge the sensor bulb fully into the ice bath, ensuring complete immersion.

### Viewing Control Value:

Monitor the control value displayed on the testing equipment. If the temperature does not read 32°F, proceed to the next step.

### Measuring Resistance:

If the control value deviates from 32°F, measure the resistance of the sensor using appropriate equipment.

The expected resistance at 32°F should be 27.22 Kilo ohms.

### Conclusion:

Testing temperature sensors in an ice bath at 32°F is essential for maintaining HVAC system functionality. By following the procedures outlined in this manual, technicians can effectively evaluate sensor performance and ensure accurate temperature readings for optimal system operation.

## 5. Sensor Location

This section is an overview of the various sensors located throughout the cabinet.

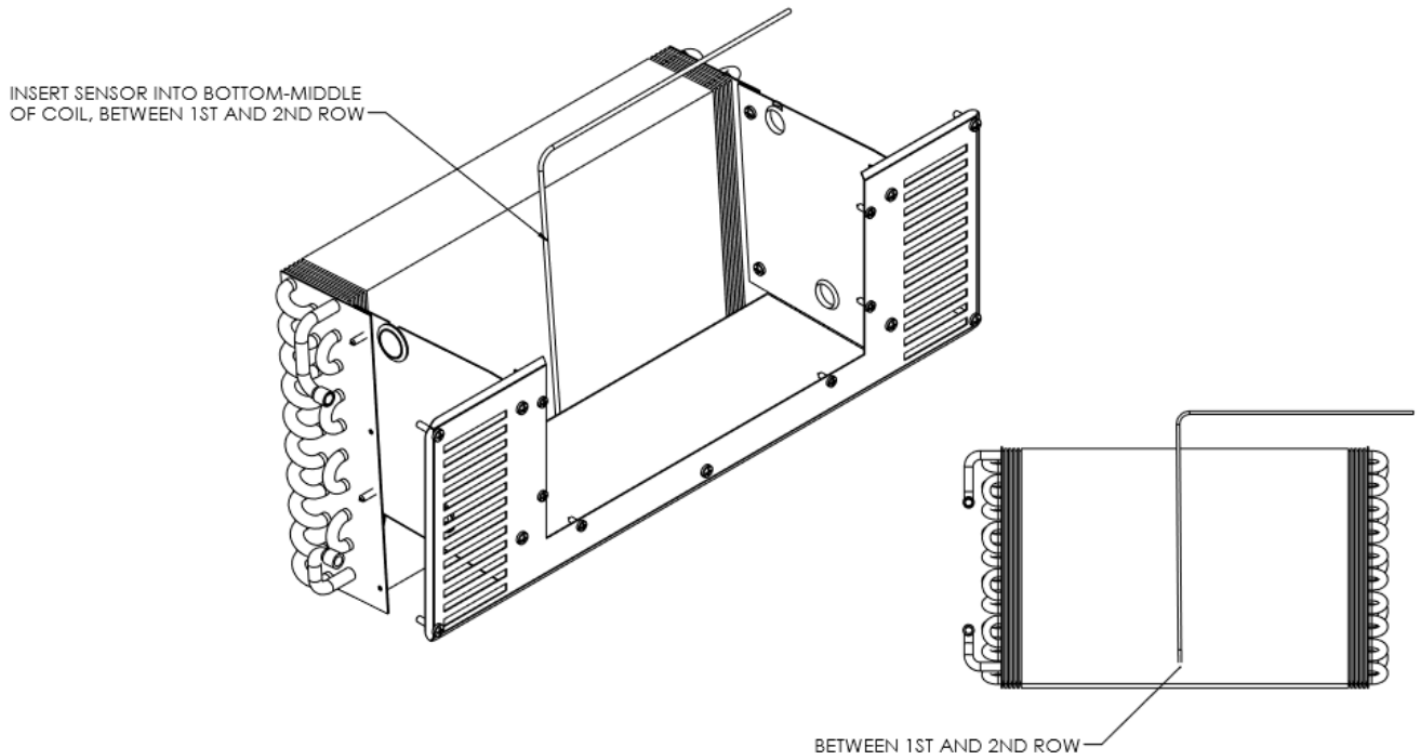
**Sensor Identification:T1 (Cabinet sensor) which is mounted on the side of the evaporator housing.**

This sensor control compressor on/off cycle based on the Cabinets temp S

**T2-Blue Sensor (Evaporator Coil):positioned in the evaporator coil. This sensor is positioned within the coil fins**

This sensor plays a vital role in monitoring the coil temperature to ensure proper defrost termination. (55 deg)

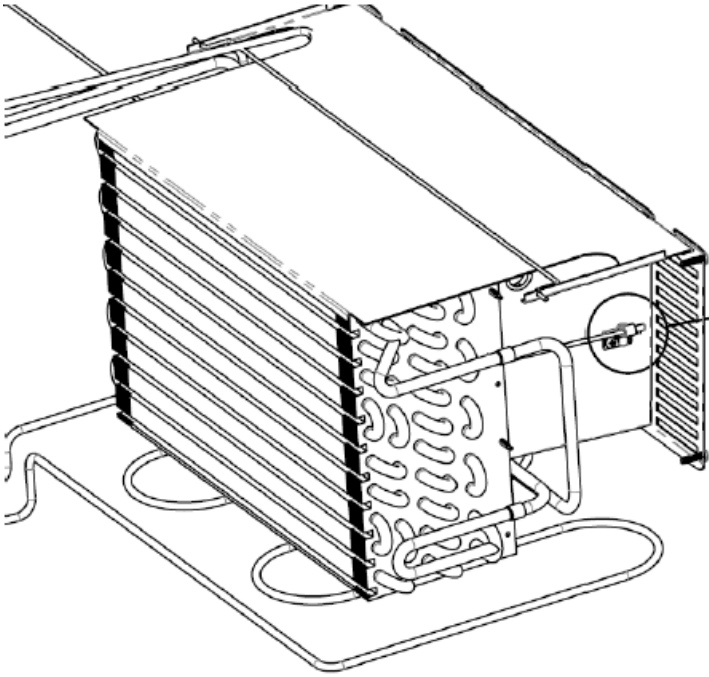
**Blue Sensor Location evaporator coil sensor placement pictured below**



### T1-Grey Sensor (Return Air):

Locate the T1-Grey sensor situated in the return air duct. This sensor is critical for monitoring the air temperature before it enters the HVAC system.

#### Grey Sensor Location cabinet/return sensor



Sensor Data	Part Number
Blue Sensor Coil	334-60488-03
Grey Sensor Coil	334-60489-03
Display Cable	333-60523-00
Display	950-60534-00
Control Module	337-60493-15

Begin by removing the louvered equipment door to access the internal components. Next, carefully remove the left outside end panel from the cabinet.

This is done by unscrewing the two screws located along the bottom edge of the panel. Note that the top of the panel is not fastened; it is designed to slide out from under the top assembly with ease. Take care to avoid bending or damaging the panel during removal.

**Before detaching the gray cabinet sensor from its original position, it is crucial to mark the sensor to preserve its correct placement.**

#### **Removing the Grey Sensor:**

Locate the grey sensor, which is secured to a mounted bracket behind the evaporator coil. Carefully inspect the mounting method to determine how the sensor is fastened. Typically, the sensor is held in place by a spring clip or plastic retainer on the bracket. Using your fingers or a small flathead screwdriver, gently release the sensor from the bracket. Be cautious not to apply excessive force, as this could damage the sensor or the mounting hardware.

#### **Disconnecting the Sensor:**

Once the sensor is free from the bracket, follow the wiring back to its connection. Disconnect the sensor from the board by gently pulling the connection away from the spade. Avoid pulling on the wires themselves, as this may cause damage to the connection.

By following these steps, you can safely and effectively remove the grey sensor from its mounted bracket for maintenance, inspection, or replacement. Always refer to the manufacturer's guidelines for any additional details specific to your unit.

## 5.1 Sensor Resistance Test

To check if the sensor is reading accurately:

- Place sensor bulb in a glass of ice with a little bit of water in it (32°F)
- Use Ohm meter to test resistance. At 32°F resistance should be 27.2KΩ.

### Resistance Curve:

<b>Resistance Curve:</b>			
<b>Temp C</b>	<b>Resistance K Ohms</b>	<b>Resistance Ohms</b>	<b>Temp F</b>
-40.0	195.767	195767.0	-40.0
-25.0	87.596	87596.0	-13.0
-20.0	68.263	68263.0	-4.0
-15.0	53.667	53667.0	5.0
-10.0	42.518	42518.0	14.0
-5.0	33.900	33900.0	23.0
0.0	27.224	27224.0	32.0
5.0	22.025	22025.0	41.0
10.0	17.928	17928.0	50.0
15.0	14.675	14675.0	59.0
20.0	12.081	12081.0	68.0
25.0	10.000	10000.0	77.0
30.0	8.314	8314.0	86.0

**Table 5.1 Resistance Test Curve**

## **6. UL/IEC/CE**

### **6A.1 Electrical Outputs for Refrigerant Detection System**

The device shall have an output to indicate the presence of a refrigerant concentration exceeding the set point.

The REFRIGERANT SENSORS and controls shall be configured such that a failure of the controls or sensor turns on the indoor fan to deliver  $Q_{min}$  or greater as defined in Annexes GG and 101.DVG. For ADD-ON HEATPUMPS a failure of the REFRIGERANT SENSOR or controls shall turn on the indoor fan at the highest available speed or to not less than  $Q_{min}$  as determined in Annex GG.

Vibration requirements of IEC 60079-29-1 for fixed gas detection sensors need not apply to the entire appliance.

### **6A.2 Refrigerant Detection System Self-test Routine**

The refrigerant detection system shall include a means for self-testing to determine if a REFRIGERANT SENSOR or sensing element malfunction has occurred. The self-test shall include missing REFRIGERANT SENSOR (open circuit), by-passed REFRIGERANT SENSOR (shorted circuit), and REFRIGERANT SENSOR output out of range.

The test shall be run at least every hour, and if a failure is detected, the device shall take the actions in accordance with Clause 6.1

If the REFRIGERANT SENSOR is a LIMITED LIFE REFRIGERANT SENSOR and requires replacement after a given period, then the device shall take the actions prescribed in Clause 6.1 at the end of the specified life and shall provide indication that replacement is required. Compliance is checked by inspection.

### **6A.3 Serviceability**

REFRIGERANT SENSORS shall be accessible for inspection, and replacement. REFRIGERANT SENSORS for replacement shall be specified by the appliance manufacturer.

### **6A.4 Refrigerant Sensor Identification**

The REFRIGERANT SENSORS shall be marked or tagged with

- A) name, trademark, or identification mark of the manufacturer or responsible vendor;
- B) reference number or other means for identifying the refrigerant sensor; and
- C) "This refrigerant sensor shall only be replaced with manufacturer approved sensor". If the SENSOR is only replaceable as part of an assembly of parts, then the assembly shall be marked.

### **6A.5 Qualification of Workers**

To minimize the risk of possible ignition due to improper service or incorrect parts. Servicing shall only be carried out by factory authorized service personnel certified to work on refrigeration systems containing flammable refrigerants.

EPA Section 608

Certified Refrigeration Service Technician (CRST)

## 6A.6 Information on servicing

### 6A.6.1 Checks to the area



This appliance is marked with the ISO 7010-W021 warning label to indicate the presence of FLAMMABLE REFRIGERANTS. Prior to beginning work on systems containing FLAMMABLE REFRIGERANTS, safety checks are necessary to ensure the risk of ignition is minimized. For repair to the REFRIGERATING SYSTEM, follow the instructions outlined in sections 6A.6.2 to 6A.6.5 prior to conducting work on the system.

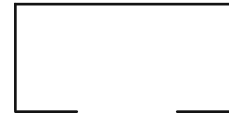
**Verifying refrigerant is important for the safe and efficient operation of HVAC systems. Refrigerant testing can help identify contaminants like moisture, acid, and particulate matter, which can damage equipment and compromise performance. It can also help identify leaks, which can lead to refrigerant loss and environmental damage.**

#### Minimum Floor Area Requirements:

##### **Regulatory Basis:**

- Safety standards for flammable refrigerants dictate that to avoid creating hazardous concentrations of gas in case of a leak, the refrigerant must be diluted in a sufficiently large room.
- The minimum floor area of 7.1 square meters ensures that in the event of a leak, the concentration of R290 does not reach flammable levels.

Minimum  
Ventilation Area  
7.1m<sup>2</sup>



#### Specific Requirements:

##### **Ventilation:**

- The room where the unit is installed must be well-ventilated to prevent the accumulation of flammable gas.
- Proper ventilation helps disperse any leaked refrigerant, reducing the risk of reaching a flammable concentration.

##### **Location Restrictions:**

- The unit must not be installed in lobbies or corridors. These areas typically have higher foot traffic, and placing flammable refrigerants there could pose a greater risk to public safety.
- Restricting installation to less trafficked areas reduces potential ignition sources and the number of people exposed to risk.

#### Practical Implications:

##### **For Installers and Users:**

- When installing units with R290 refrigerant, professionals must ensure that the room meets the minimum floor area requirement of 7.1 square meters.
- Additionally, they must verify that the space has adequate ventilation and is not a high-traffic area like a lobby or corridor.

##### **Compliance with Standards:**

- Adhering to these regulations helps ensure compliance with international safety standards, which is crucial for legal and insurance purposes.
- It also enhances safety for end-users by minimizing the risk of accidents associated with refrigerant leaks.

By understanding and following these requirements, stakeholders can ensure the safe and effective use of R290 refrigerant in refrigeration systems, balancing environmental benefits with necessary safety precautions.

### **6A.6.2 Work Procedure**

Work shall be undertaken under a controlled procedure so as to minimize the risk of a flammable gas or vapor being present while the work is being performed.

### **6A.6.3 General work area**

All maintenance staff and others working in the local area shall be instructed on the nature of work being carried out. Work in confined spaces shall be avoided.

### **6A.6.4 Checking for presence of refrigerant**

The area shall be checked with an appropriate refrigerant detector prior to and during work, to ensure the technician is aware of potentially toxic or flammable atmospheres. Ensure that the leak detection equipment being used is suitable for use with all applicable refrigerants, i.e., non sparking, adequately sealed, or intrinsically safe.

### **6A.6.5 Presence of fire extinguisher**

If any hot work is to be conducted on the refrigerating equipment or any associated parts, appropriate fire extinguishing equipment shall be available on hand. A dry chemical or CO2 fire extinguisher should be adjacent to the charging area.

### **6A.6.6 No ignition sources**

No person carrying out work in relation to a REFRIGERATING SYSTEM which involves exposing any pipe work shall use any sources of ignition in such a manner that it may lead to the risk of fire or explosion. All possible ignition sources, including cigarette smoking, should be kept sufficiently far away from the site of installation, repairing, removing and disposal, during which refrigerant can possibly be released to the surrounding space. Prior to work taking place, the area around the equipment shall be surveyed to make sure that there are no flammable hazards or ignition risks. "No Smoking" signs shall be displayed.

### **6A.6.7 Ventilated area**

Ensure that the area is in the open or that it is adequately ventilated before breaking into the system or conducting any hot work. A degree of ventilation shall continue during the period that the work is carried out. The ventilation should safely disperse any released refrigerant and preferably expel it externally into the atmosphere.

### **6A.6.8 Checks to the refrigerating equipment**

Where electrical components are being changed, they shall be fit for the purpose and to the correct specification. At all times, the manufacturer's maintenance and service guidelines shall be followed. If in doubt, consult the manufacturer's technical department for assistance.

The following checks shall be applied to installations using FLAMMABLE REFRIGERANTS:

- A) the actual REFRIGERANT CHARGE is in accordance with the room size within which the refrigerant containing parts are installed;
- B) the ventilation machinery and outlets are operating adequately and are not obstructed;
- C) if an indirect refrigerating circuit is being used, the secondary circuit shall be checked for the presence of refrigerant;
- D) marking to the equipment continues to be visible and legible. Markings and signs that are illegible shall be corrected;
- E) refrigerating pipe or components are installed in a position where they are unlikely to be exposed to any substance which may corrode refrigerant containing components, unless the components are constructed of materials which are inherently resistant to being corroded or are suitably protected against being so corroded.

### **6A.6.9 Checks to electrical devices**

Repair and maintenance to electrical components shall include initial safety checks and component inspection procedures. If a fault exists that could compromise safety, then no electrical supply shall be connected to the circuit until it is satisfactorily dealt with. If the fault cannot be corrected immediately but it is necessary to continue operation, an adequate temporary solution shall be used. This shall be reported to the owner of the equipment, so all parties are advised.

Initial safety checks shall include:

- A) that capacitors are discharged: this shall be done in a safe manner to avoid possibility of sparking;
- B) that no live electrical components and wiring are exposed while charging, recovering or purging the system;
- C) that there is continuity of earth bonding.

### **6A.7 Repairs to sealed components**

During repairs to sealed components, all electrical supplies shall be disconnected from the equipment being worked upon prior to any removal of sealed covers, etc. If it is absolutely necessary to have an electrical supply to equipment during servicing, then a permanently operating form of leak detection shall be located at the most critical point to warn of a potentially hazardous situation.

Particular attention shall be paid to the following to ensure that by working on electrical components, the casing is not altered in such a way that the level of protection is affected. This shall include damage to cables, excessive number of connections, terminals not made to original specification, damage to seals, incorrect fitting of glands, etc.

Ensure that the apparatus is mounted securely.

Ensure that seals or sealing materials have not degraded to the point that they no longer serve the purpose of preventing the ingress of flammable atmospheres. Replacement parts shall be in accordance with the manufacturer's specifications.

### **6A.8 Repair to intrinsically safe components**

Do not apply any permanent inductive or capacitive loads to the circuit without ensuring that this will not exceed the permissible voltage and current permitted for the equipment in use.

Intrinsically safe components are the only types that can be worked on while live in the presence of a flammable atmosphere. The test apparatus shall be at the correct rating.

Replace components only with parts specified by the manufacturer. Other parts can result in the ignition of refrigerant in the atmosphere from a leak.

NOTE The use of silicon sealant can inhibit the effectiveness of some types of leak detection equipment. Intrinsically safe components do not have to be isolated prior to working on them.

### **6A.9 Cabling**

Check that cabling will not be subject to wear, corrosion, excessive pressure, vibration, sharp edges, or any other adverse environmental effects. The check shall also take into account the effects of aging or continual vibration from sources such as compressors or fans.

### **6A.10 Detection of flammable refrigerants**

Under no circumstances shall potential sources of ignition be used in the searching for or detection of refrigerant leaks. A halide torch (or any other detector using a naked flame) shall not be used.

The following leak detection methods are deemed acceptable for all refrigerant systems. Electronic leak detectors may be used to detect refrigerant leaks but, in the case of FLAMMABLE REFRIGERANTS, the sensitivity might not be adequate, or might need recalibration. (Detection equipment shall be calibrated in a refrigerant-free area.) Ensure that the detector is not a potential source of ignition and is suitable for the refrigerant used. Leak detection equipment shall be set at a percentage of the LFL of the refrigerant and shall be calibrated to the refrigerant employed, and the appropriate percentage of gas (25 % maximum) is confirmed.

Leak detection fluids are also suitable for use with most refrigerants but the use of detergents containing chlorine shall be avoided as the chlorine can react with the refrigerant and corrode the copper pipe-work.

NOTE Examples of leak detection fluids are

- bubble method,
- fluorescent method agents.

If a leak is suspected, all naked flames shall be removed/extinguished.

If a leakage of refrigerant is found which requires brazing, all of the refrigerant shall be recovered from the system, or isolated (by means of shut off valves) in a part of the system remote from the leak. Removal of refrigerant shall be according to.

### **6A.11 Removal and evacuation**

When breaking into the refrigerant circuit to make repairs - or for any other purpose - conventional procedures shall be used. However, for flammable refrigerants it is important that best practice be followed, since flammability is a consideration. The following procedure shall be adhered to:

- A) safely remove refrigerant following local and national regulations;
- B) purge the circuit with inert gas;
- C) evacuate;
- D) purge with inert gas;
- E) open the circuit by cutting or brazing.

The refrigerant charge shall be recovered into the correct recovery cylinders if venting is not allowed by local and national codes. For appliances containing flammable refrigerants, the system shall be purged with oxygen-free nitrogen to render the appliance safe for flammable refrigerants. This process might need to be repeated several times. Compressed air or oxygen shall not be used for purging refrigerant systems.

For appliances containing flammable refrigerants, refrigerants purging shall be achieved by breaking the vacuum in the system with oxygen-free nitrogen and continuing to fill until the working pressure is achieved, then venting to atmosphere, and finally pulling down to a vacuum. This process shall be repeated until no refrigerant is within the system (optional for A2L). When the final oxygen-free nitrogen charge is used, the system shall be vented down to atmospheric pressure to enable work to take place.

Ensure that the outlet for the vacuum pump is not close to any potential ignition sources and that ventilation is available.

### **6A.12 Charging procedures**

In addition to conventional charging procedures, the following requirements shall be followed.

- A) Ensure that contamination of different refrigerants does not occur when using charging equipment. Hoses or lines shall be as short as possible to minimize the amount of refrigerant contained in them.
- B) Cylinders shall be kept in an appropriate position according to the instructions.
- C) Ensure that the REFRIGERATING SYSTEM is earthed prior to charging the system with refrigerant.
- D) Label the system when charging is complete (if not already).
- E) Extreme care shall be taken not to overfill the REFRIGERATING SYSTEM.

Prior to recharging the system, it shall be pressure-tested with the appropriate purging gas. The system shall be leak-tested on completion of charging but prior to commissioning. A follow up leak test shall be carried out prior to leaving the site.

## 6A.13 Decommissioning

Before carrying out this procedure, it is essential that the technician is completely familiar with the equipment and all its detail. It is recommended good practice that all refrigerants are recovered safely. Prior to the task being carried out, an oil and refrigerant sample shall be taken in case analysis is required prior to re-use of recovered refrigerant. It is essential that electrical power is available before the task is commenced.

- A) Become familiar with the equipment and its operation.
- B) Isolate the system electrically.
- C) Before attempting the procedure, ensure that:
  - I) mechanical handling equipment is available, if required, for handling refrigerant cylinders;
  - II) all personal protective equipment is available and being used correctly;
  - III) the recovery process is supervised at all times by a competent person;
  - IV) recovery equipment and cylinders conform to the appropriate standards.
- D) Pump down refrigerant system, if possible.
- E) If a vacuum is not possible, make a manifold so that refrigerant can be removed from various parts of the system.
- F) Make sure that cylinder is situated on the scales before recovery takes place.
- G) Start the recovery machine and operate in accordance with instructions.
- H) Do not overfill cylinders (no more than 80 % volume liquid charge).
- I) Do not exceed the maximum working pressure of the cylinder, even temporarily.
- J) When the cylinders have been filled correctly and the process completed, make sure that the cylinders and the equipment is removed from site promptly and all isolation valves on the equipment are closed off.
- K) Recovered refrigerant shall not be charged into another REFRIGERATING SYSTEM unless it has been cleaned and checked.

## 6A.14 Labeling

Equipment shall be labeled stating that it has been de-commissioned and emptied of refrigerant. The label shall be dated and signed. For appliances containing FLAMMABLE REFRIGERANTS, ensure that there are labels on the equipment stating the equipment contains FLAMMABLE REFRIGERANT.

## 6A.15 Recovery

When removing refrigerant from a system, either for servicing or decommissioning, it is recommended good practice that all refrigerants are removed safely.

When transferring refrigerant into cylinders, ensure that only appropriate refrigerant recovery cylinders are employed. Ensure that the correct number of cylinders for holding the total system charge is available. All cylinders to be used are designated for the recovered refrigerant and labeled for that refrigerant (i.e., special cylinders for the recovery of refrigerant). Cylinders shall be complete with pressure-relief valve and associated shut-off valves in good working order. Empty recovery cylinders are evacuated and, if possible, cooled before recovery occurs.

The recovery equipment shall be in good working order with a set of instructions concerning the equipment that is at hand and shall be suitable for the recovery of all appropriate refrigerants including, when applicable, FLAMMABLE REFRIGERANTS. In addition, a set of calibrated weighing scales shall be available and in good working order. Hoses shall be complete with leak-free disconnect couplings and in good condition. Before using the recovery machine, check that it is in satisfactory working order, has been properly maintained and that any associated electrical components are sealed to prevent ignition in the event of a refrigerant release. Consult manufacturer if in doubt.

The recovered refrigerant shall be returned to the refrigerant supplier in the correct recovery cylinder, and the relevant waste transfer note arranged. Do not mix refrigerants in recovery units and especially not in cylinders.

If compressors or compressor oils are to be removed, ensure that they have been evacuated to an acceptable level to make certain that FLAMMABLE REFRIGERANT does not remain within the lubricant. The evacuation process shall be carried out prior to returning the compressor to the suppliers. Only electric heating to the compressor body shall be employed to accelerate this process. When oil is drained from a system, it shall be carried out safely.

## 6A.16 Warning Notices

This appliance is not intended for use by persons (including children) with reduced physical, sensory or mental capabilities, or lack of experience and knowledge, unless they have been given supervision or instruction concerning use of the appliance by a person responsible for their safety.

**WARNING** Children should be supervised to ensure that they do not play with the appliance.

This appliance is rated for use in Climatic Class 5. This appliance can operate in an environment with maximum ambient temperatures of 104° F (40° C) and 40% RH.

Product is suitable for use up to 6500 ft (2000m).

**WARNING** Power cord should only be replaced with a Traulsen-specified part.

**WARNING** Appliances that use a flammable refrigerant shall indicate that component parts shall be replaced with like components so as to minimize the risk of possible ignition due to incorrect parts.

Maximum loading per shelf is 200 lbs (91 kg)

**WARNING** Do not store explosive substances such as aerosol cans with a flammable propellant in this appliance.

Review all flammable refrigerant cautions for completeness.

**WARNING** Keep clear of any obstructions for all ventilation openings of the appliance enclosure.

**WARNING** Do not use mechanical devices or other means to accelerate the defrosting process, other than those recommended by the manufacturer.

**WARNING** Do not damage the refrigerating circuit. Do not pierce or burn.

**WARNING** Do not use electrical appliances inside the food/ice storage compartments unless they are of the type recommended by the manufacturer.

Taking care to avoid causing a fire by igniting flammable material.

Install in accordance with the Safety Standard for Refrigeration Systems, ANSI/ASHRAE 15.

**WARNING** Do not use means to accelerate the defrosting process or to clean, other than those recommended by the manufacturer.

**WARNING** The appliance shall be stored in a room with out continuously operating ignition sources ( for example: open flames, an operating gas appliance or an operating electric heater.

**WARNING** Be aware that refrigerants may not contain an odor.

### General precautions when working on an R-290 (propane) refrigeration system:

- Notify all persons in the immediate area that you are working with a flammable refrigerant.
- Insure the work area is well ventilated.
- Use a combustible gas monitor to measure propane concentration in the air.
- Beware of flammable materials present in the work area.
- Extinguish ignition sources within 10 feet of the work area if possible.
- Have a Class B dry powder type fire extinguisher available.
- Use spark-resistant tools.
- Use extra care while servicing the unit to avoid damage to refrigerant tubing, condenser, and evaporator coils.
- Always use appropriate PPE (Personal Protection Equipment).

### Examples of ignition sources:

- A spark from an electrical source such as:
  - Contactors
  - Relay
  - Defrost heaters
  - Condensate pan heaters
  - Door switches
  - Light bulbs
  - Electrical outlets
  - Switches
  - Electrical drill
  - Static electricity
- Open flame ignition sources such as:
  - Fryers
  - Cigarettes/lighters
  - Gas appliances
  - Griddles
- Tools:
  - Non-spark resistant tools
  - Heat guns
  - Torches

## 6B. Troubleshooting

**⚠ WARNING** Certain procedures in this section require electrical tests or measurements while power is applied to the machine. Exercise extreme caution at all times. If test points are not easily accessible, disconnect power and follow lockout/tagout procedures, attach test equipment and reapply power to test.

### 6B.1 Additional Requirements & Precautions for Servicing R-290 (Propane) Systems

#### Key Terms:

**Lower Explosive Limit (LEL)** - The lowest concentration of a gas or vapor in the air capable of producing a flash fire in the presence of an ignition source (arc, flame, heat). A concentration lower than the LEL is not rich enough to burn. The LEL of R-290 (propane) is 2.1% concentration by volume of air.

**Upper Explosive Limit (UEL)** - The highest concentration of a gas or vapor in the air capable of producing a flash of fire in the presence of an ignition source (arc, flame, heat). Concentration higher than the UEL is too rich to burn. The UEL for R-290 (propane) is 9.5% concentration by volume of air.

**EPA/SNAP** - Environmental Protection Agency/Significant New Alternative Policy. The EPA approved the conditional use of R-290 (propane) refrigerant in new equipment in 2011.

**Global Warming Potential (GWP)** - A measure of the greenhouse gases' ability to trap radiant energy, with carbon dioxide assigned a value of 1. R-448A and R-450A have values of 1273 and 546 respectively. R-290 (propane) has only a value of 3.

**Hydrocarbon Refrigerants (HC)** - Hydrocarbon refrigerants are a select group of hydrocarbons that are non-toxic, non-ozone depleting substances that are being used to replace more traditional refrigerants.

**Ozone Depletion Potential (ODP)** - A measure of the refrigerant's ability to destroy stratospheric ozone. Modern HFC refrigerants such as R448-A and R-450A have an ODP of zero. Hydrocarbon refrigerants such as R-290 (propane) also have an ODP of zero.

**Flash Point** - Flash point is the minimum temperature at which a substance will burn with an ignition source. The flash point of R-290 (propane) is -150°F.

**Auto Ignition Temperature** - The auto ignition temperature is the temperature at which a fuel will ignite without the need for a spark or flame. The auto ignition temperature of R-290 (propane) is 896°F.

**Well Ventilated** - Any area or space where air flow can enter and exit freely.

**Confined Space** - Per OSHA, a confined space is defined as:

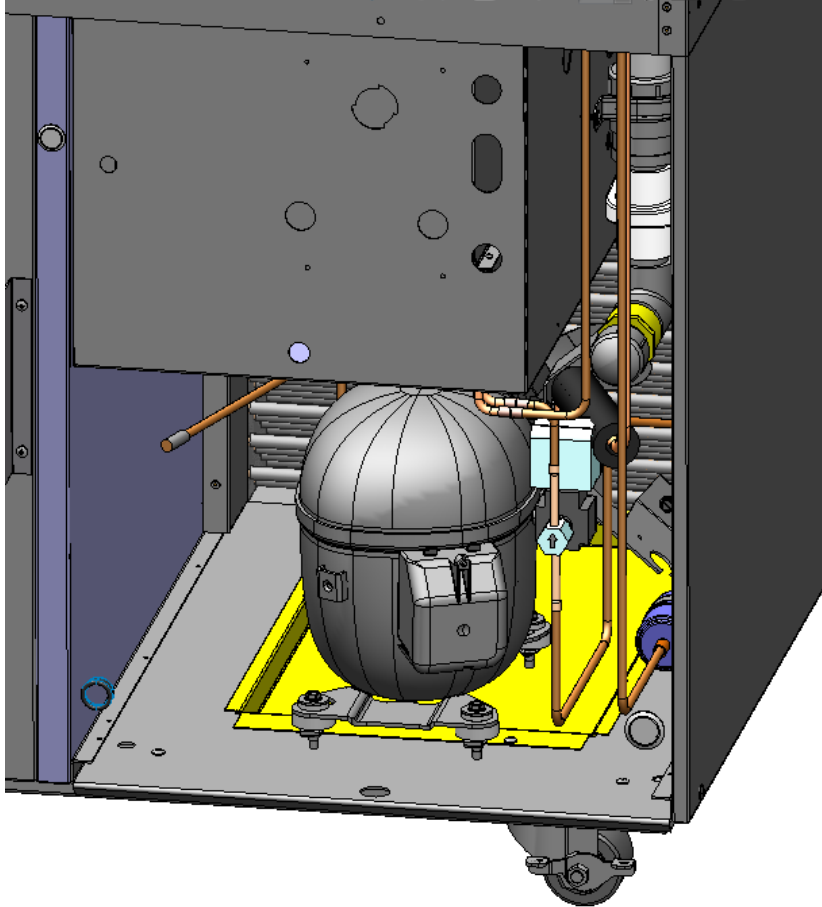
- Large enough for an employee to enter fully and perform assigned work.
- Not designed for continuous occupancy by the employee.
- Has a limited or restricted means of entry or exit.

**Personal Protection Equipment (PPE)** - This list is not meant to be all encompassing, but should include: safety glasses, knee protection or kneeling aid, first aid kit, fire extinguisher, insulated screwdriver set, LOTO kit, ear plugs, slip resistant black leather safety toe shoes, electrical glove kit (rubber glove and "goatskin protector"), cut resistant gloves, cut resistant sleeves, heat resistant sleeves, GFCI cord set, fall prevention kit, nitrile gloves, chemical goggles, ARC flash barrier tape, hard hat with ARC flash rated face shield, and ARC flash rated balaclava.

For models contained R-290 (propane) as a refrigerant, all instructions labeled on the unit must be closely followed. Service and repair must be performed by qualified refrigeration technicians familiar with applicable safety standards for flammable refrigerants. Technician must use appropriate personal protective precautions to avoid risk of fire or explosion.

## 6B.2 Condensate Overflow Troubleshooting

### 6B.2.1 Condensate Overflow



**Fig. 6B.2.1 Troubleshooting Condensate Pan Overflow**

The condensate pan generally does not overflow unless there is an excess of ambient air infiltrating the cabinet.

- The door is not sealed properly.
- Door not self-closing (see door section).
- **Wicking cards need to be changed**

## 6B.3 Leak Checking System

A number of means for leak detection may be considered:

- Bubble test
- Holding pressure test (refer to serial tag for maximum system pressure)
- Electronic leak detector

**Never use any dyes or other contaminants when working with Traulsen refrigeration systems.**

For R-290 (propane) systems, make sure the electronic leak detector being used is designed to detect R-290 (propane). A combustible gas monitor may also be used to indicate the presence of a leak.

## 6B.4 Accessing the Refrigeration System

Piercing valves can be used to access the refrigeration system. Access ports should be temporarily placed on the process tube (suction and/or liquid line) as close to the end of the process tube as possible.

Do **NOT** leave piercing valves on this system. If you cannot finish the repair you will need to use Lock/Out-Tag/Out procedures.

- Pinch line off just before the temporary access port three times using a crimper tool.
- Verify that there are no leaks.
- Remove the piercing valve/temporary access port.
- Cut off the copper tubing between the location of the temporary access port removed in step 3 and the crimps made in step 1.
- Braze open end shut.
- Leak check the system.



## 6B.5 Refrigerant Recovery

For refrigeration systems using R-290 (propane), the U.S. EPA has allowed venting to the atmosphere due to its low environmental impact. Use the following process. This process requires the use of a combustible gas monitor.

1. If the refrigeration system is located in a confined area, consider using the refrigerant recovery process noted above. The R-290 (propane) can then be vented later in a safe location.
2. Venting must not be to a public area with people present that are unaware of the procedure.
3. The technician responsible for venting R-290 (propane) must make all persons in the immediate area aware a flammable gas is being released to the atmosphere.
4. Ensure there are no ignition sources within 10 ft. of the area you are venting R-290 (propane).
5. Ensure that all local legislation addressing safety of hazardous or flammable substances are satisfied.
6. Like most other refrigerants, R-290 (propane) is heavier than air. Ensure you are not venting it into a low-lying area.

## 6B.6 Repair of Leaks

It is of utmost importance to properly repair refrigerant leaks as soon as they are discovered. If they cannot be repaired immediately, the refrigerant charge should be removed from the system until the point at which the leak can be repaired. A number of considerations are relevant when attempting to repair a leak:

- Repair the leak properly - this means removing the refrigerant, examining the leak source, determining the reason for the leak and carrying out the proper course of action.
- Before repairing the leak, ensure that the refrigerant has been removed and the system flushed with nitrogen if brazing is to take place.
- Always run low pressure nitrogen through the system when brazing as this reduces the risk of oxidation. For R-290 (propane) systems, this also reduces the risk of combustible gas ignition.
- It is **absolutely not acceptable** to leave line tap valves or piercing valves attached to the system.

## 6B.7 System Evacuation

After the system has been sealed and leak checked, it is necessary to evacuate it in order to remove air, moisture, and unwanted residual refrigerant.

- With R-290 (propane) systems, first purge the system with nitrogen. This will prevent flammable mixtures from occurring.
- When connecting the hoses between the system, gauge manifolds, and vacuum pump, ensure that the connections are secure. For R-290 (propane) systems, ensure that there are no potential ignition sources nearby.
- For R-290 (propane) systems, ensure that the pump discharge is in an area free of potential ignition sources.
- Ensure that a micron gauge is used since conventional manifold gauges may not provide proper readings.
- The system should be evacuated to the desired pressure (typically 250 microns or less) and then left to stand for 15 minutes to ensure that the entire refrigerant charge has been removed from the oil and any residual moisture has been evaporated from the system.
- Ensure that the vacuum pump is of good quality and of appropriate capacity for the system, and the oil level is correct.

## 6B.8 Charging the System

After the proper evacuation of the system, the following process should be followed:

1. Process Tube needs to be extended.
  - Remove the crimped tubing and piercing or saddle valve from the process tube.
  - Extend the process tube a minimum of 12".
  - Crimp and braze the process tube extension.
  - Install piercing or saddle valve just after the last crimp.
2. Evacuate the system following the SYSTEM EVACUATION section in this document.
3. Charge the system.
  - **DO NOT OVERCHARGE THE SYSTEM.** You must weigh in the exact charge.
  - Prior to charging, ensure the system has been leak checked.
  - Hoses or lines should be as short as possible to minimize the amount of refrigerant contained in them.
  - Evacuate the hoses and manifold prior to charging to avoid contamination of the refrigerant.
  - Upon completion of charging, a further leak check must be carried out prior to leaving the site.
  - After charging, carefully disconnect the hoses, attempting to minimize the release of refrigerant.
  - After charging, all access ports must be removed following the **REMOVE ACCESS PORTS** section in this document.

## 6B.9 Remove Access Ports

Do **NOT** leave piercing valves on this system. If you cannot finish the repair you will need to use Lock/Out-Tag/Out procedures.

1. Pinch line off just before the temporary access port three times using a crimper tool.
2. Verify that there are no leaks.
3. Remove the piercing valve/temporary access port.
4. Cut off the copper tubing between the location of the temporary access port removed in step 3 and the crimps made in step 1.
5. Braze open end shut.
6. Leak check the system following the **LEAK CHECKING SYSTEM** section in this document.

## 6B.10 Compressor Troubleshooting

### 6B.10.1 Terminology

**OEM** - Original Equipment Manufacturer, refers to the manufacturer of a piece of equipment or component.

**RLA** - Rated Load Amps, the OEM test conditions amperage rating (does not necessarily indicate the normal running amperage as conditions and applications can vary from OEM test conditions).

**LRA** - Locked Rotor Amps, the OEM test condition lock rotor amperage rating indicating the expected amperage at which a motor does not turn when power is applied.

**Microfarad** - This is a unit of measure for capacitance; the symbol for **Microfarad** is  $\mu\text{F}$ .

**Current** - The flow of electrons in an electrical circuit measured in Amps with an Amp Meter.

**Resistance** - The opposition to the flow of electrical current measured in Ohms with an Ohm Meter; the symbol for Ohms is  $\Omega$ .

**Back EMF** - The voltage generated by the start winding once the compressor runs which is higher than line voltage.

**Pick-up Voltage** - The back EMF value at which the normally closed contacts of a potential relay open.

First verify that the Call for Cooling LED on this display is illuminated. See Control Section.

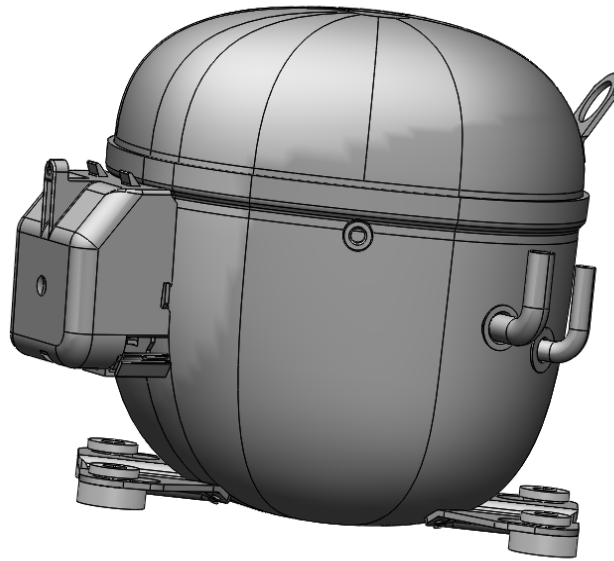


Fig. 6B.10 Compressor

### 6B.10.2 Accessing The Compressor

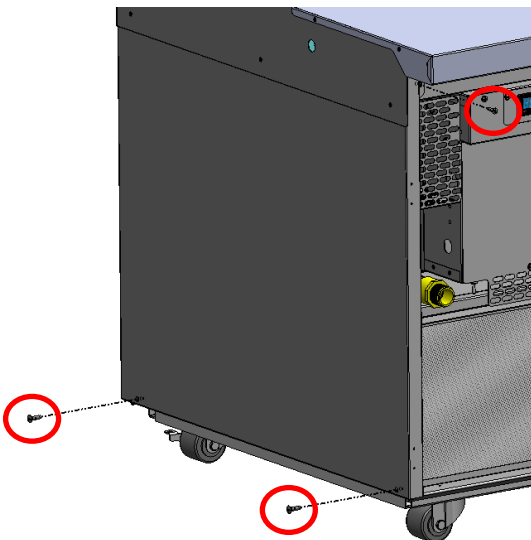


Fig. 6B.10.2a Remove (5) Screws

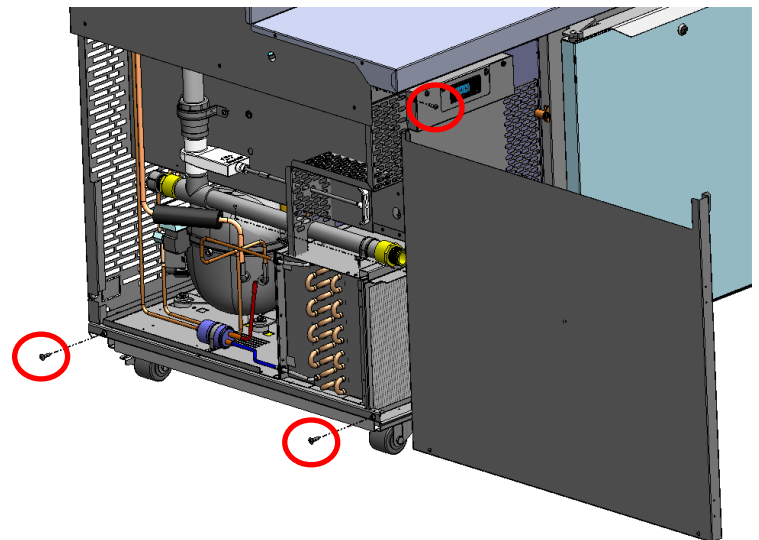


Fig. 6B.10.2b Remove Condenser Housing

### 6B.10.3 Compressor Not Running

If the condenser fan motor is running but not the compressor, the compressor may be overheated. Carefully place your hand on the dome of the compressor. If the compressor is very hot, the external overload protector may be open. Disconnect power to the unit and give the compressor ample time to cool.

### 6B.10.4 Testing the Windings of the Compressor

After the compressor has been sufficiently cooled, remove all the start components from the compressor. Now use an Ohms Meter to measure the resistance of the windings, comparing the resistance values measured with the values given in **Table 5.2**. Be careful when measuring resistance to make a good connection to each terminal with your meter lead. Take several measurements to ensure you are consistently getting the same values. If the resistance values are consistent but do not match the values given below, replace the compressor with OEM replacement.

### 6B.10.5 Resistance and AMP Values of TS-SERIES Compressors

Compressor Information			Resistance		Current	
Traulsen Part Number	Embraco Model	Copeland Model	Start Winding	Run Winding	RLA	LRA
321-60300-00	EMX4140U	N/A-	N/A-	N/A	6.4A	30.6

### 6B.10.6 Troubleshooting Compressor Failure

Verify Incoming Voltage

Before diagnosing the inverter or compressor, confirm that the unit is receiving the proper voltage.

- Using a multimeter, measure the voltage at the main power terminals.
- Ensure the voltage matches the specifications listed on the unit's data plate.
- If voltage is out of range, check the power supply, circuit breakers, and wiring connections.

### 6B.10.7 Check Inverter Power and Functionality

- Locate the inverter module and inspect its status lights.
- The green heartbeat LED indicates normal operation.
- If solid green, the inverter is powered but not running the compressor.
- If blinking green, the inverter is functioning normally.
- If no light, the inverter may not be receiving power or may be faulty.
- If red LED is on, this indicates a fault condition; refer to the inverter fault code chart. ( see below)

**Measure incoming voltage at the inverter:**

**Verify correct voltage between L1 and L2 terminals.**

**If voltage is incorrect, trace wiring back to the power source.**

### 6B.10.8 Verify Compressor Windings (CRS Check)

Disconnect power and discharge capacitors before testing compressor windings.

Using a multimeter set to resistance (Ohms), check resistance between:

- C (Common) and R (Run) terminals
- C (Common) and S (Start) terminals
- R (Run) and S (Start) terminals

**6B.10.9 Compare the readings to manufacturer specifications. If readings are significantly high or infinite (open circuit), the compressor windings are damaged.**

- Check for a short to ground:
- Set the multimeter to continuity mode.
- Test each compressor terminal to ground.
- If continuity is detected, the compressor is grounded and must be replaced.

### Check Refrigerant pressures

Verify the system is properly charged using manifold gauges.

Inspect for refrigerant leaks around service ports, evaporator, and condenser coils.

Low refrigerant charge can cause the compressor to fail due to overheating or improper lubrication.

### Inverter Fault Reset and Restart

If the inverter has a fault condition, reset it by powering down the unit for at least five minutes, then restoring power.

Observe inverter lights upon restart.

If the fault persists, replace the inverter or consult the manufacturer's troubleshooting guide.

### Final Assessment

If the compressor windings test good but does not run, suspect an inverter issue.

If the inverter is providing proper voltage but the compressor does not start, replace the compressor.

**If both the inverter and compressor pass all checks but the unit still does not function, inspect additional components such as sensors, control boards, and wiring connections**

**Note: In R290 refrigeration systems equipped with an inverter, the use of start and run capacitors is unnecessary. The inverter directly controls the compressor motor by varying the frequency and voltage, enabling efficient operation and seamless start-up without the need for traditional capacitor components.**

### 6B.10.11 Locked Up Compressor

After all start components have been properly tested and determined to be good and the proper voltage has been verified, the compressor does not start while the current spikes up to the LRA, this could be indicative of an internal mechanical problem within the compressor. If so, replace the compressor with OEM replacement. See **Table 6B.10.5** for Traulsen part number and OEM model number.

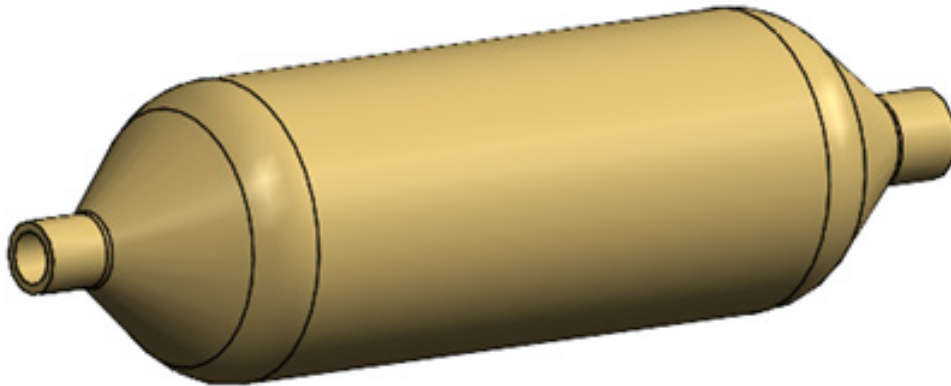
### 6B.10.12 Current Climbs Above RLA

See section on Troubleshooting Run Capacitor first. If the amps start out at RLA but climb higher until the external overload protector opens, this could be an indication of poor air circulation through the condenser coil resulting in higher head pressure. The solution could be as simple as cleaning the condenser coil or a problem with the condenser fan motor, such as tight bearings or a fan blade that has been installed backwards. If none of the above, this could also be a symptom of an internal mechanical problem within the compressor. If so, replace the compressor with OEM replacement.

**Note:** When a system is overcharged, the compressor current may be above RLA.

### 6B.10.13 Replacing the Compressor

If you have taken all the proper steps outlined above to troubleshoot the compressor, and therefore have determined the compressor has failed, **be sure to replace the liquid line filter drier along with the compressor (Traulsen Part Number 325-60103-00)**. Traulsen recommends that you use a nitrogen flow regulator to purge with low pressure nitrogen as you braze all connections. After you have brazed all connections and have checked thoroughly for leaks, change the oil in your vacuum pump before connecting to system with a micron gauge. Pull a deep vacuum of 200 microns to remove moisture from the system.



**Fig. 6B.10.13 Filter Drier**

### 6B.10.14 Compressor Wiring Schematics

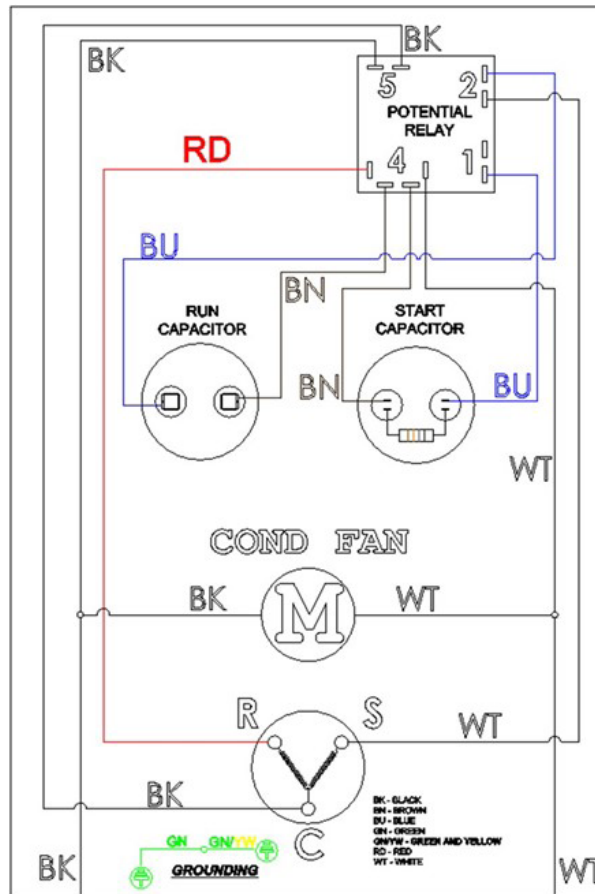


Fig. 6B.10.14a Capacitor Run/  
Capacitor Start Compressors

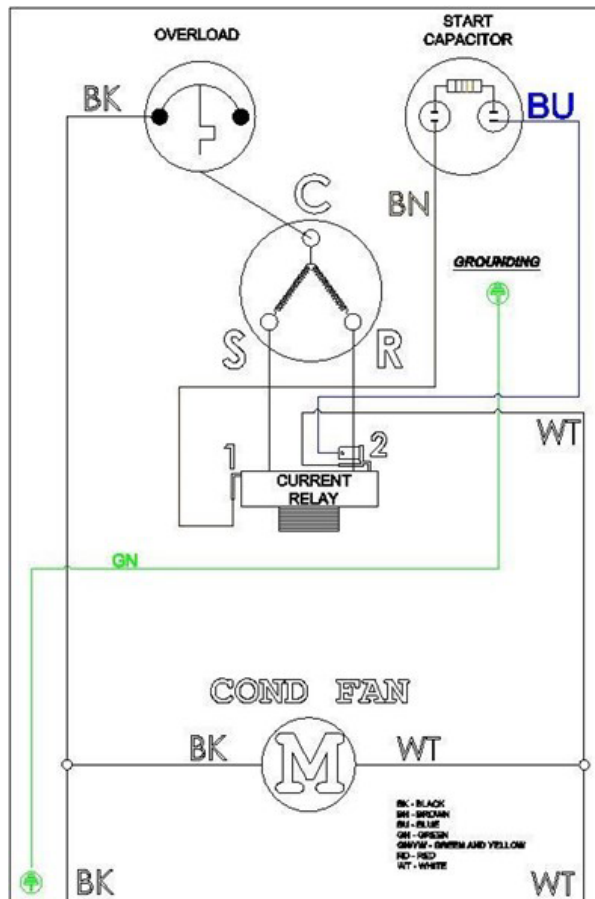
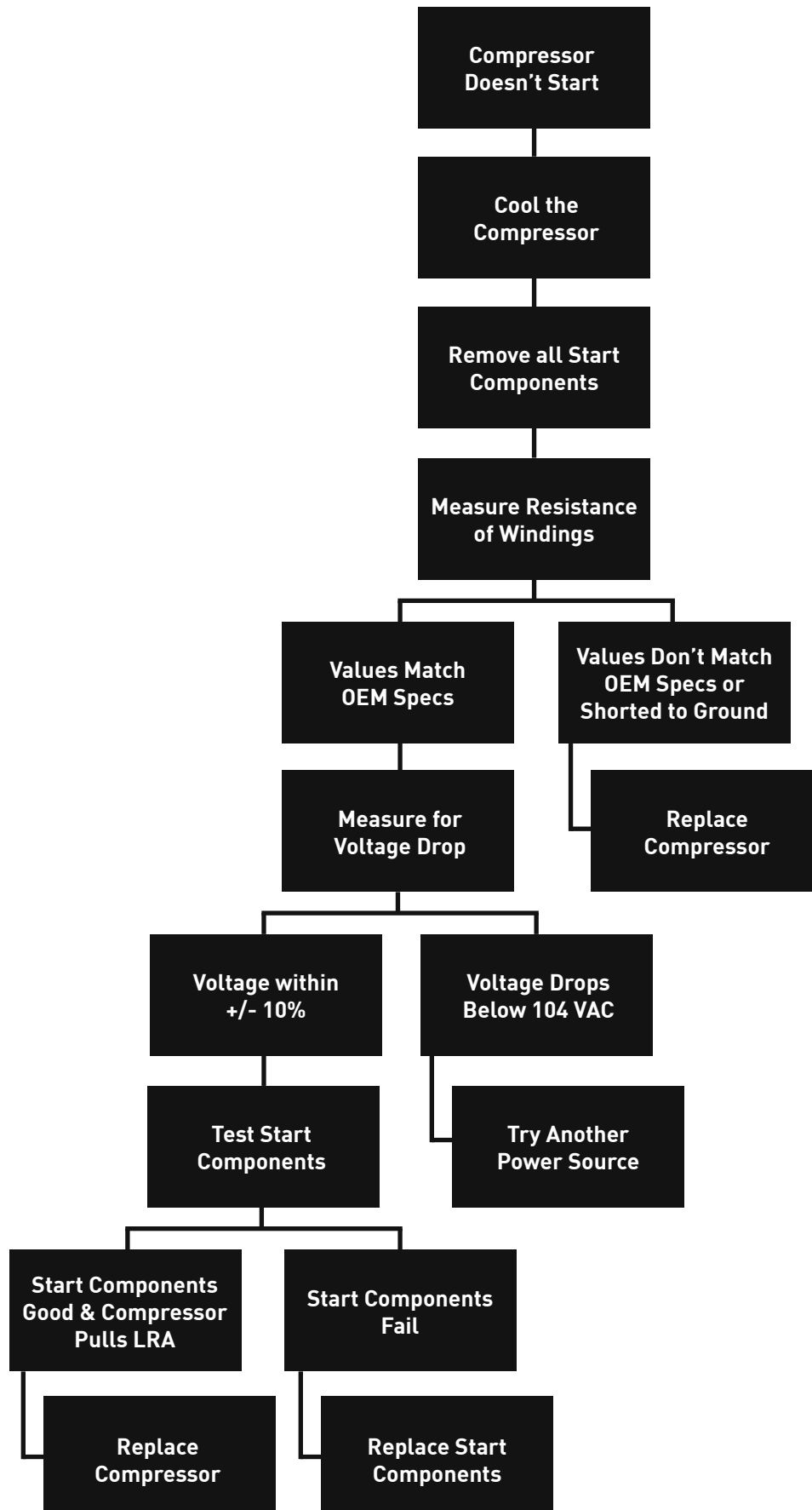
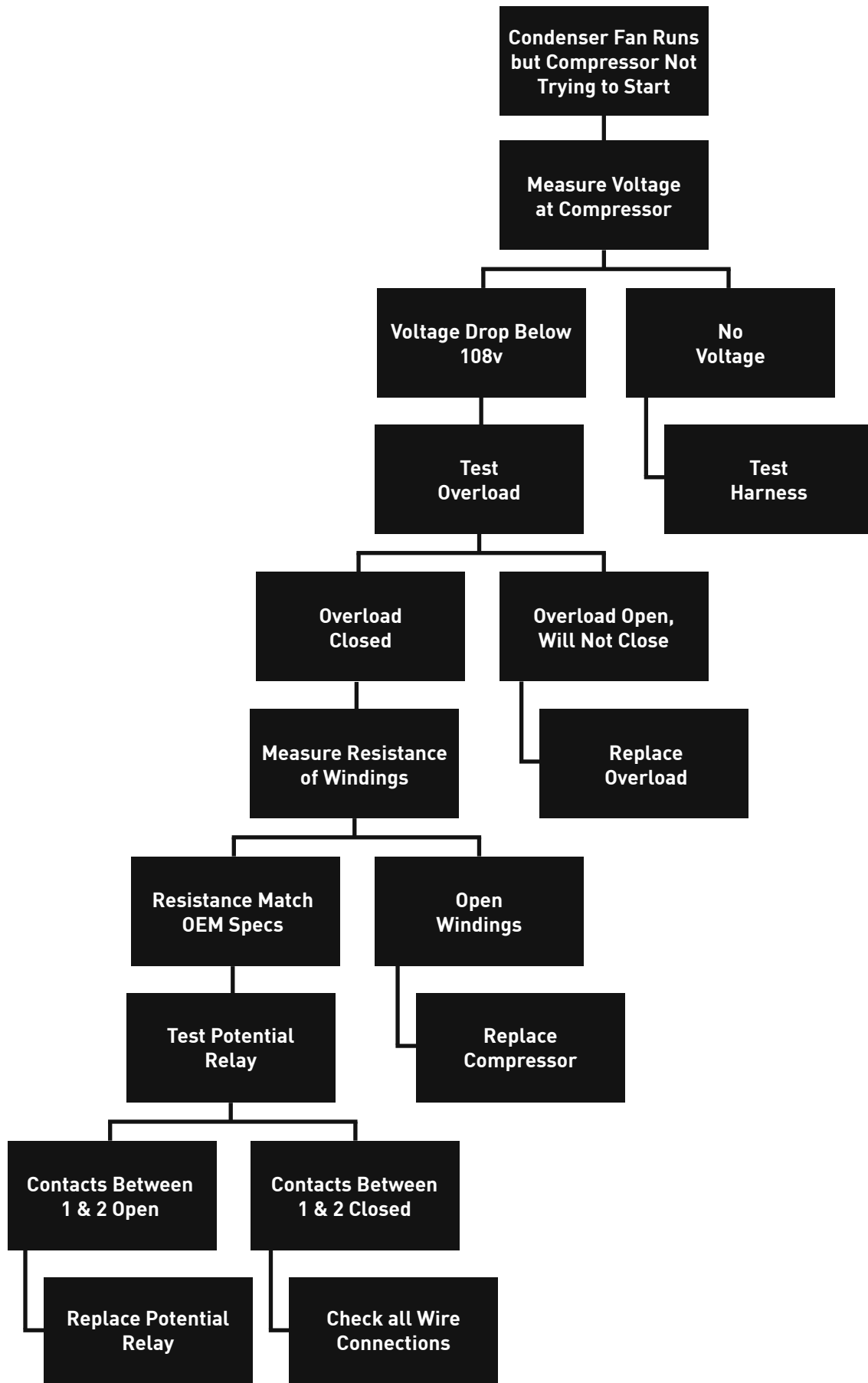


Fig. 6B.10.14b Induction Run  
Capacitor Start Compressors

## 6B.10.15 Compressor Short Cycles on Overload Protection

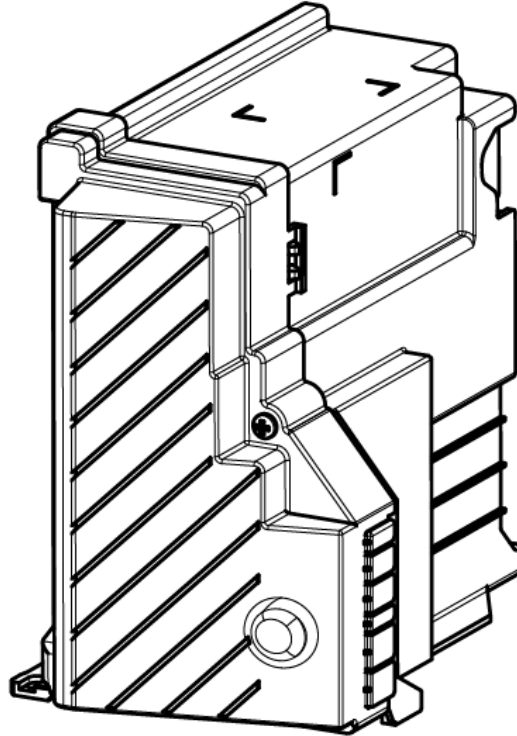


6B.10.16 Compressor Not Trying to Start



## 6B.11 CF10B Electric Inverter

### 6B.11.1 General Product Specifications



CF10B Embraco Electric Inverter

<b>General Specifications</b>	
Input rated voltage range <sup>i</sup>	120 V or 240 V
Input operating voltage range <sup>ii, iii, iv</sup>	70 V-140 V or 160 V-264 V
Maximum input voltage <sup>v, vi</sup>	176 V or 300 V
Input frequency range	50-60 Hz
Input rated current	15.5 A
Input rated power	1000 W
Control mode	Frequency, Drop-in and Serial
Fan driver maximum current	1 A
Operating humidity	← 85%
Environmental humidity <sup>vii</sup>	10% to 85%
Operating ambient temperature <sup>viii</sup>	-20° C to 55° C
Storage temperature	-40° C to 85° C
Air forced ventilation (min) <sup>ix</sup>	2 m/s

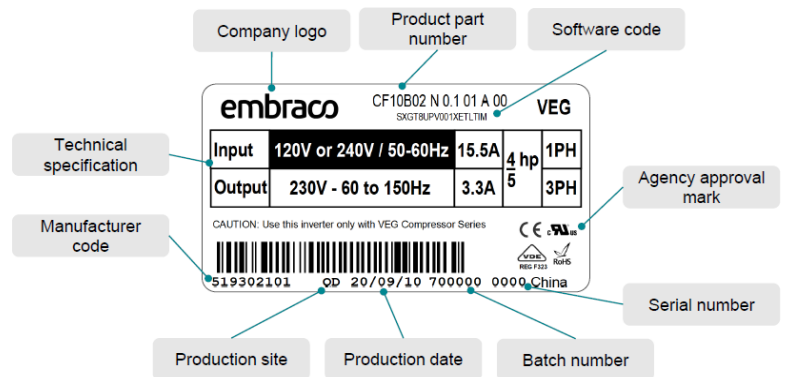
## 6B.11.2 Technical Specifications



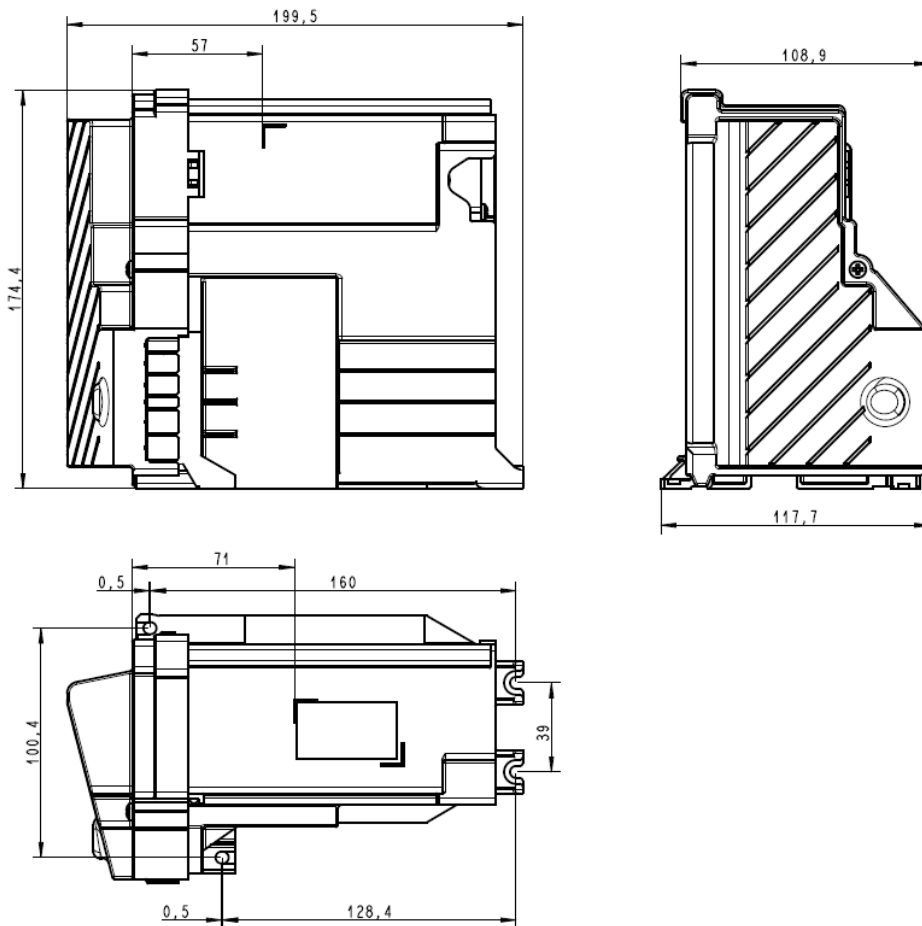
- Do not connect the CF10B Inverter to a power supply above declared Maximum voltage.



- This inverter is for use only with the Embraco VCC compressors.
- Operating the product at voltages out of declared Input operating voltage range may reduce its reliability and significantly impair product performance.
- Make sure to apply the proper Inverter - VCC match. The use of incorrect Inverter - VCC may degrade product overall performance.
- In order to avoid loss of performance, make sure to operate the inverter inside the temperature range of -20 °C to 55 °C.
- Ambient operation temperature above 55 °C or inappropriate positioning of the inverter related to forced ventilation air flow may activate inverter thermal protection.

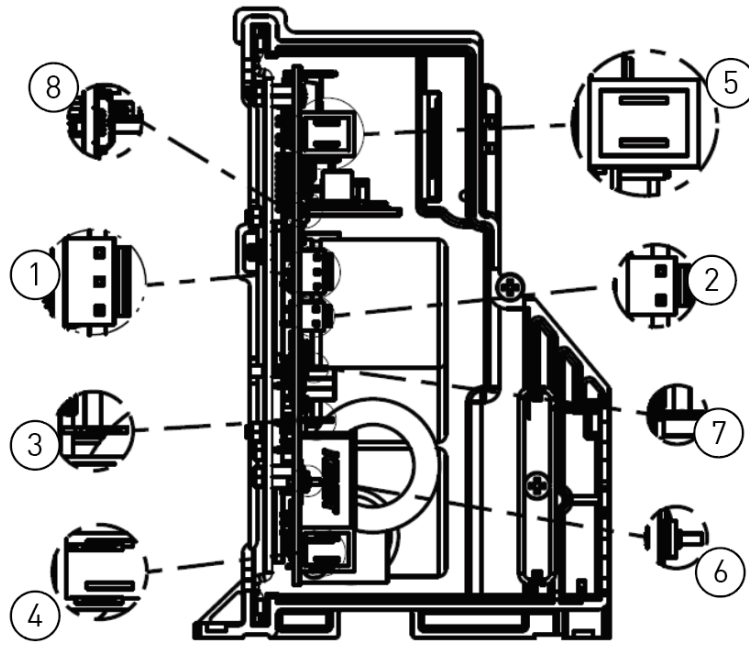


Label Identification



CF10B Product Dimensions  
Stand Alone Dimensions (mm)

### 6B.11.3 Connectors



\*Mates with 1/4" faston receptacle. Fan connector assemble is optional.

Connector Diagram

Connectors Part Numbers			
Indicator	Description	Part Number	Insulation
1	Serial Communication	S3P-VH (LF) (SN)	Reinforced
2	Frequency input	S2P-VH (LF) (SN)	Reinforced
3	Drop in	1217754-1	Non-insulated
4	AC input (L+N)	1217754-1	Non-insulated
5	AC Fan*	MSLO 9402 - 002 - 00A - 960 - 000 - 00	Non-insulated
6	EMI Earth	Cable supplied by embraco	
7	Defrost input	1217754-1	Non-insulated
8	"You Control" input	Micro-USB B	Non-insulated

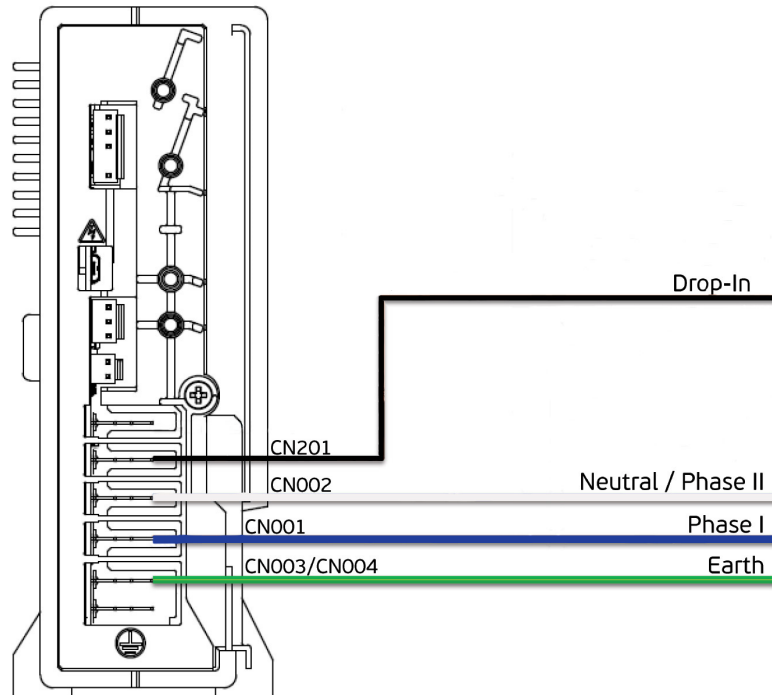


• The 'You Control' customization input (micro USB port) does not have electrical insulation. Use the provided communication modules defined by Embraco to guarantee electrical insulation. Check Subsection 4.2.2 for information regarding the indicated communication modules and product customization.

#### NOTICE

• CF10B inverter series standard configuration is approved to be used only in built in appliances, with not accessible machine compartment. If the intended appliance is an open machine compartment type, please contact Embraco's technical support to ensure the proper configuration of your product.

## 6B.11.4 Connection



**Energized Contact Drop-in Connection**

## 6B.11.5 LED Indication

The LED diagnostics function helps services technicians to diagnose possible fault components by blinking a LED inside the box in different patterns. Basically, it indicates if there is a problem with Compressor, CF10B Inverter or Thermostat. The table below describes the failure modes.

Led Status	Period	Color	Description
<b>1 Flash</b>	30 Seconds	Green	Normal Operation
<b>2 Flashes</b>	5 Seconds	Green	Communication Problem
<b>3 Flashes</b>	5 Seconds	Red	Inverter Problem
<b>4 Flashes</b>	5 Seconds	Red	Compressor Problem
<b>No Flashes</b>	-	-	No Input Power / Damaged Inverter

### 6B.11.6 Troubleshooting

The following tables shows some possible problems and the best action to deal with them.

<b>Compressor Does Not Start</b>	
<b>Problem</b>	<b>Action</b>
Compressor disconnected from the inverter.	Verify compressor cable connection
No AC power supply; or wrong voltage/terminals connected.	Verify AC input cable connection and measure AC input voltage.
No control signal input or bad connection.	Verify control input cable connection and measure the signal from the thermostat.
Blown fuse (due to previous major failure).	Return the unit to manufacturer, replacing it by new one.
Open compressor motor winding.	Measure winding for open circuit between all pair of pins on the hermetic terminal. If any winding is open, return compressor to manufacturer.
Compressor with locked rotor (due to mechanical damage).	Replace compressor by new one and test for confirmation. Return damaged unit to manufacturer.
Dropped, damaged, burnt inverter.	Replace by new one and test for confirmation. Return damaged unit to manufacturer.
Inverter on waiting time after failed start.	Wait the necessary time or reset the inverter disconnecting it from the AC power supply. The reset time is about 50s.
Demagnetized rotor (only if compressor was previously connected directly to the AC power supply).	Replace compressor by a new one and test for confirmation. Return damaged unit to manufacturer.
Unequaled pressures between discharge and suction pressures in the refrigerating system.	Allow the Inverter to equalize pressure between suction and discharge sides.
Low input voltage supplied to the inverter.	Measure AC voltage to confirm.

## 6B.11.7 Diagnostics

<b>Compressor does not run at the selected speed</b>	
<b>Problem</b>	<b>Action</b>
High compression load, with compressor being subjected to a stall condition.	Review system design, refrigerant gas load or compressor capacity is not suitable for the application. If system is appropriated designed, speed will reach set value when load condition is stabilized.
Compressor always on pull down cycle for Drop-In Mode.	In Drop-In mode, check if the inverter AC input is connected to thermostat output. Inverter AC input should be directly connected to AC power supply (see Drop-In mode schematic).
No or incorrect control signal.	Check if the appropriate control signal is being correctly applied to the Control Input Connection.

## 6B.12 Evaporator Fan Troubleshooting

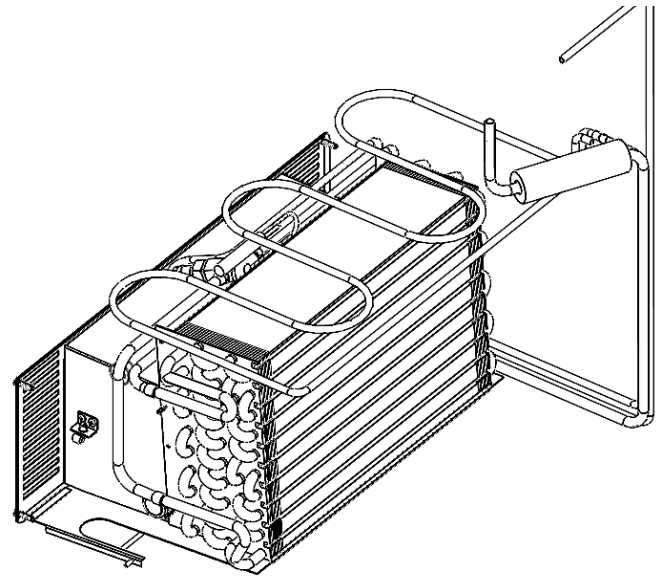
### 6B.12.1 Steps for Troubleshooting TS-SERIES Evaporator Fan

1. First verify fan icon is illuminated on the display indicating a call for the evaporator fan. The TS does not have door switches, opening door to verify prior to verify voltage



Fig. 6B.12.1a Evaporator Fan Icon On

Display PN: [950-60534-00](#)



Evaporator PN: [700-60699-00](#)

2. Next use an amp meter to prove the evaporator fan motor is running.

3. If fan motor is not running use voltage meter to measure the voltage at fan motor if measurement within +/- 10% of rated voltage replace the fan motor.

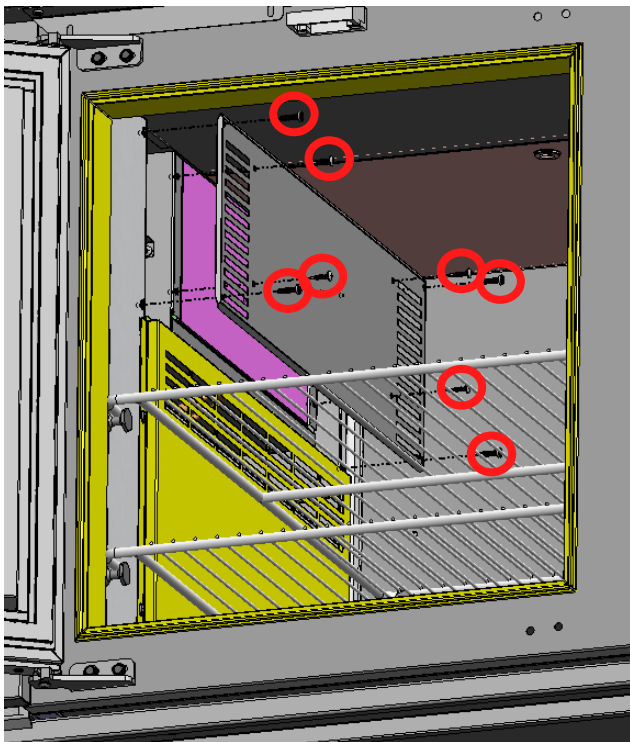


Fig. 6B.12.1b Duct Removal

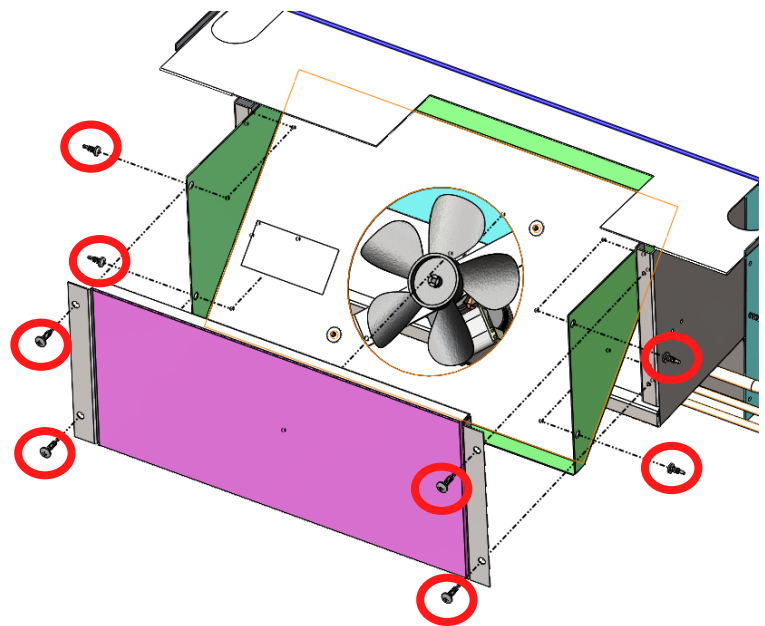
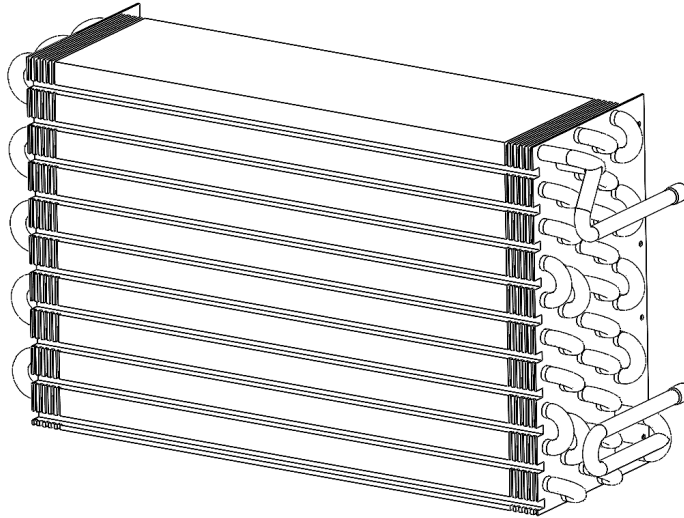
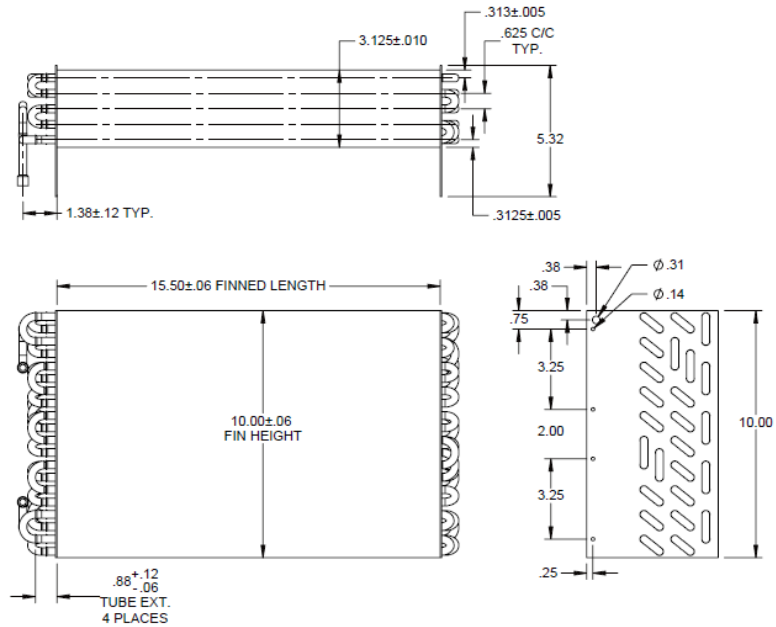


Fig. 6B.12.1c Evaporator Fan Assembly Removal

## 6B.12.2 Evaporator Unit



Sensor Data	Part Number
Evaporator, Small Coil 9x9x1.790	<a href="#">322-60144-00</a>
Evaporator, Large Coil 9x18x1.790	322-60053-01



**Fig. 6B.12.2 Evaporator coil**  
Traulsen P/N: 322-60053-01

## 6B.12.3 Evaporator Fan

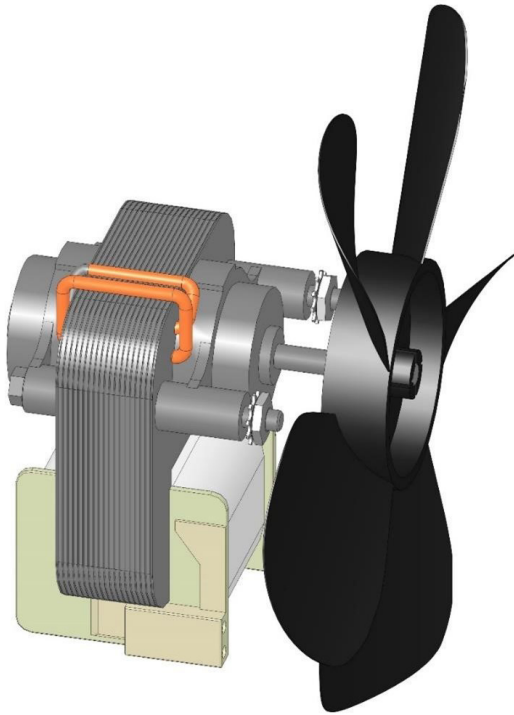


Fig. 6B.12.3a C-Frame (Shaded Pole) Fan Motor  
TRAULSEN P/N 338-60054-00

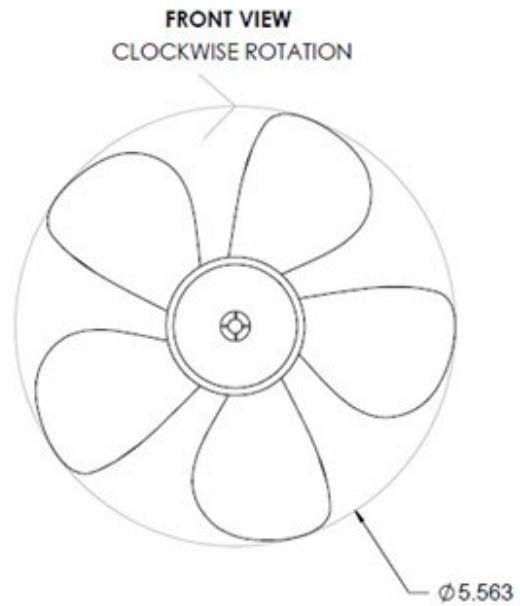


Fig. 6.12.3b Evaporator Fan Blade  
TRAULSEN P/N 325-60240-10

DESCRIPTION/ SPECIFICATION	MANUFACTURER	
	FASCO INDUSTRIES, INC.	BAY MOTOR PRODUCTS, INC.
Part Number	7102-2992	5A141-94
Amps	0.63 A	0.50 A
Voltage	115 VAC	115 VAC
Frequency	60 Hz	60 Hz
Speed	3,000 RPM	3,000 RPM
Rotation	CW	CW

Table 6B.12.3c C-Frame Fan Motor Specs

EVAPORATOR FAN BLADE SPECIFICATIONS	
COLOR	BLACK
BALANCE	0.008 INCH-OZ Max
AXIAL RUNOUT	0.056 INCH I.R. Max
RADIAL RUNOUT	0.056 INCH I.R. Max
MATERIAL	UL94-HB UNFILLED POLYPROPYLENE PP 828,3208, OR APPV'D EQUIV
INSERTION FORCE	15-40 LBF
SHAFT DIMENSION	0.181 ROUND

Table 6B.12.3d Evaporator Fan Blade

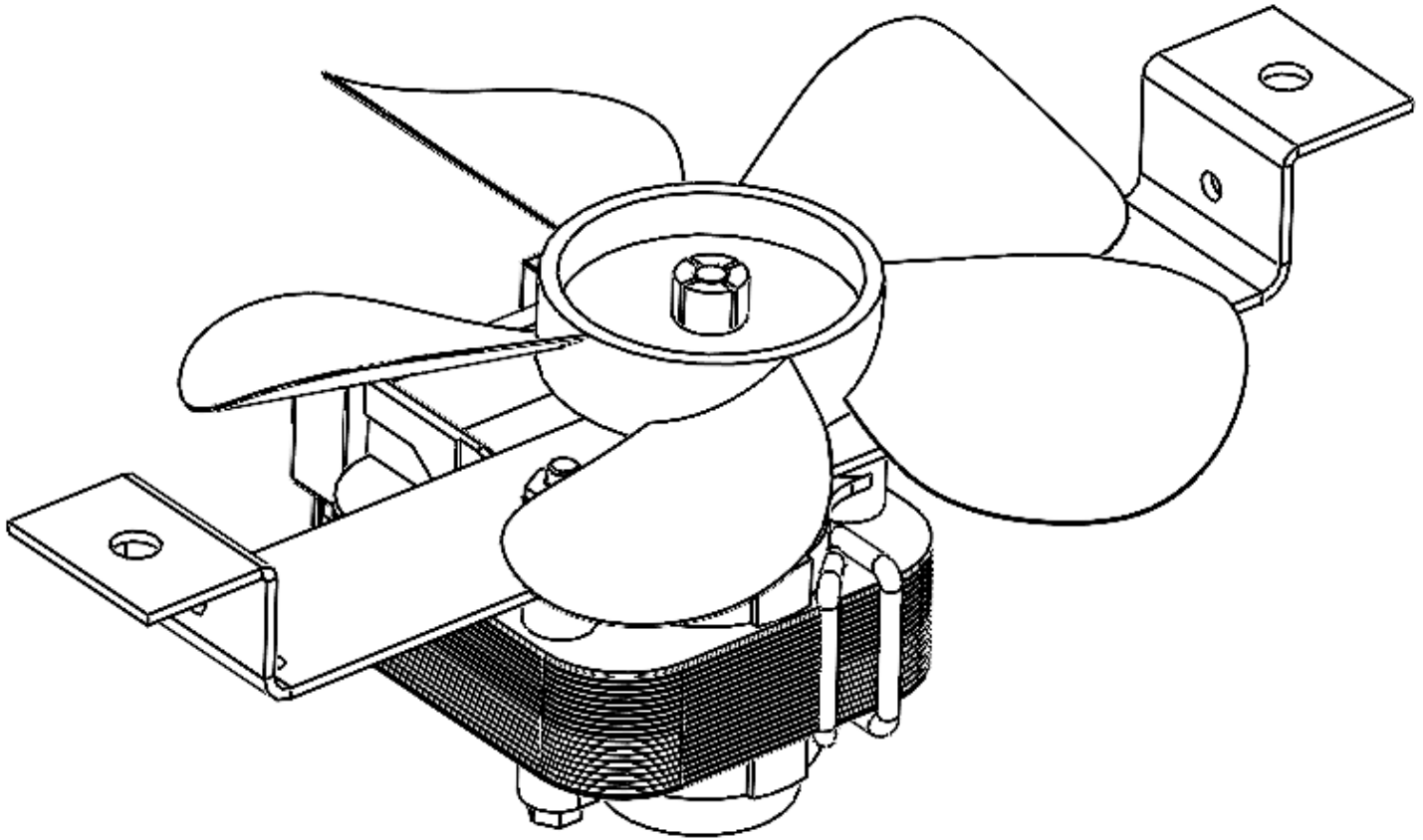


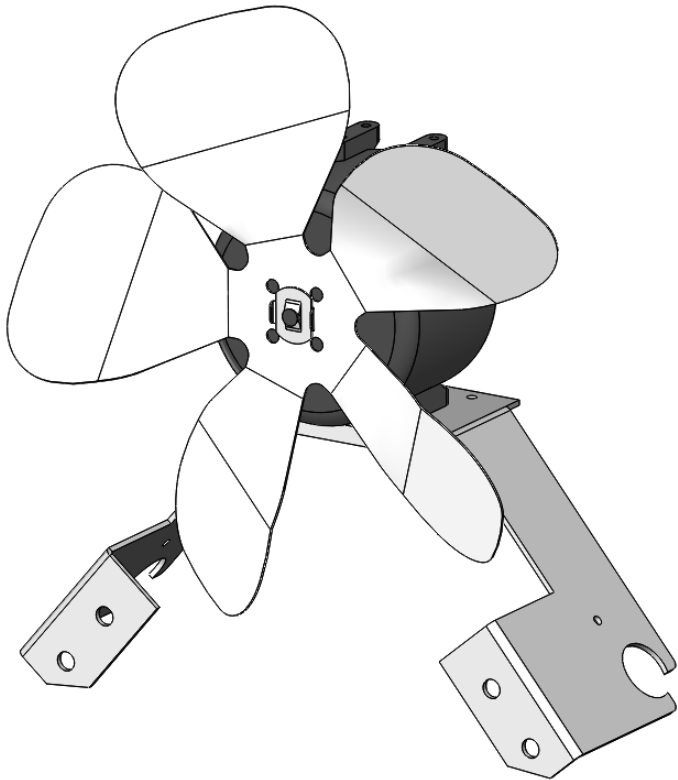
Fig. 6B.12.3e Fan motor Bracket Assembly  
 TRAUlsen P/N [900-60883-03](#)

DESCRIPTION/ SPECIFICATION	MANUFACTURER
PART NUMBER	7102-2992
OUTPUT	9 WATTS
AMPS	0.63 A
VOLTAGE	120v
FREQUENCY	50/60 Hz
SPEED	2,400 RPM
ROTATION	CW
AIR FLOW	168 CFM

Table 6B.12.3f ECM Fan Motor Specs

## 6B.13 Condenser Fan Troubleshooting

### 6B.13.1 Troubleshooting the Condenser fan Motor



**Fig. 6B.13.1a CFM Assembly**  
**TRAUlsen PN: 325-60144-00**



**Fig. 6B.13.1b LED Display**

First verify that the Call for Cooling LED on the display is illuminated. If the compressor is running but not the condenser fan motor, you should measure voltage at the condenser fan motor. If you measure +/- 10% of rated voltage but the motor doesn't run, replace the fan motor.

### 6B.13.2 Motor Bearing Failure

Problems with motor bearings can be easily overlooked- as the motor will run while the cabinet drops in temperature until the motor overheats. Once the motor overheats it will shut off on the internal overload until the motor cools sufficiently. If the condenser fan motor is making a loud grinding noise, leaking oil from the bearings, and pulling excessive current to the motor, the bearings have failed. If the condenser fan motor exhibits these motor bearing failure symptoms, replace the fan motor.

#### TRAUlsen CAST IRON 9 WATT CONDENSER MOTOR P/N: [338-60049-00](#)

DESCRIPTION/ SPECIFICATION	MANUFACTURER	
	MORRILL MOTORS, INC.	ELECTRIC MOTORS
MODEL	SP-B16LE12	SPFBG161
PART NUMBER		
OUTPUT	16 WATT	16 WATT
AMPS	.80 A	1.0 A
VOLTAGE	115 VAC	115 VAC
FREQUENCY	50/60 Hz	60 Hz
SPEED	1,550 RPM	1,550 RPM
ROTATION	CW	CW

**Table 6B.13.2 Condenser Fan Motor**

### 6B.13.3 Access and Removal of Condenser Fan Motor

STEP 1:

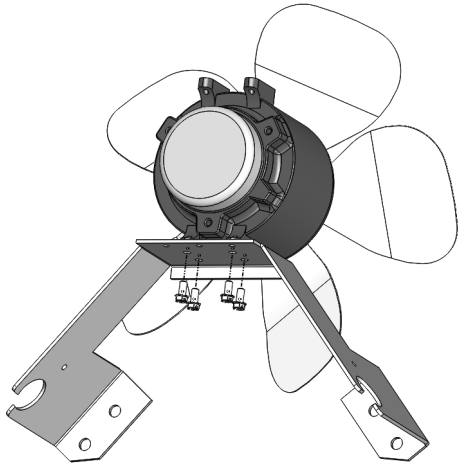


Fig. 6B.13.3.1a Remove Fan Mounting Bolts

STEP 2:

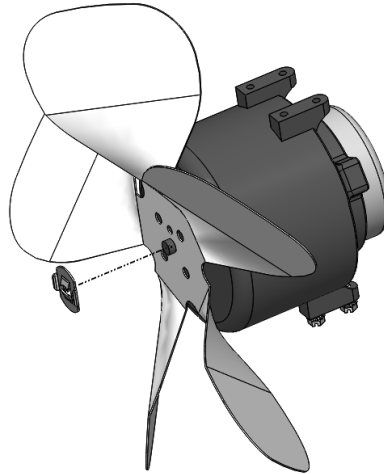


Fig. 6B.13.3.1b Remove Speed Nut

STEP 3:

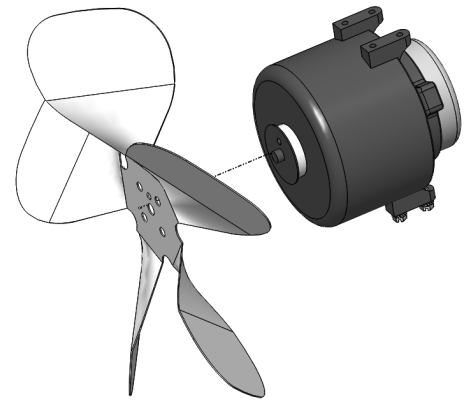


Fig. 6B.13.3.1c Remove Fan Blade

### Replacing the Condenser Fan Motor

DESCRIPTION	TRAULSEN PART NUMBER
16 w 115 VOLT Fan Motor Part#	<a href="#">338-60050-00</a>

Table 6B.13.3 Condenser Fan Motor TRAUlsen P/N

When replacing the motor, be sure to note the direction of air flow as well as the position of the fan blade. The motor is designed to pull air through the condenser coil. The fan blade should be installed with the concave toward the motor using speed nut included with the motor. The vibration washer, which is supplied with the motor, must be installed between the motor and fan blade. Torque speed nut to 10 IN-LB.

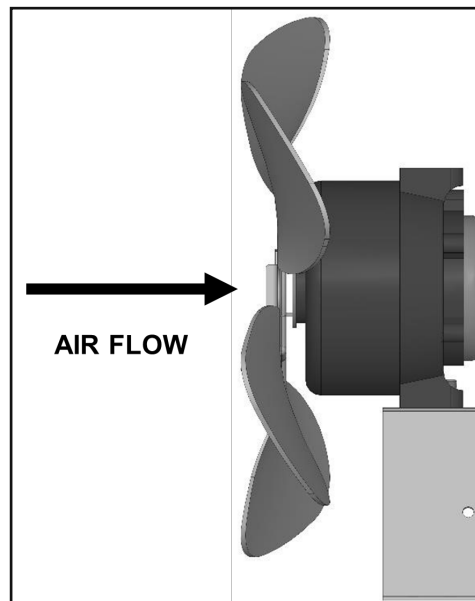


Fig. 6B.13.3 Fan Blade Orientation

Refer to the figure above to confirm the fan blade orientation when mounted on the bracket.

## 6B.14 Troubleshooting Thermostatic Expansion Valve Part #325-60081-01

All Traulsen TS-Series refrigerators and freezers are equipped with Thermostatic Expansion Valve (TXV). The TXV is a type of metering device that meters liquid refrigerant into the evaporator coil. A TXV is superior to a capillary tube metering device, as it can respond to load changes. The TXV is designed to control the superheat value of the refrigerant leaving the evaporator coil. This control of superheat is accomplished by a sensing bulb that is secured to the outlet of the evaporator coil at the suction line. When the temperature of the suction line increases at the sensing bulb (which is charged with refrigerant), the pressure in the sensing bulb increases- opening the valve. This is the only opening force upon the valve, so if the refrigerant charge is lost in the sensing bulb (powerhead) the TXV will close- starving the evaporator coil. If the sensing bulb is not attached to the suction line properly, the valve will likely open too much- flooding the evaporator.

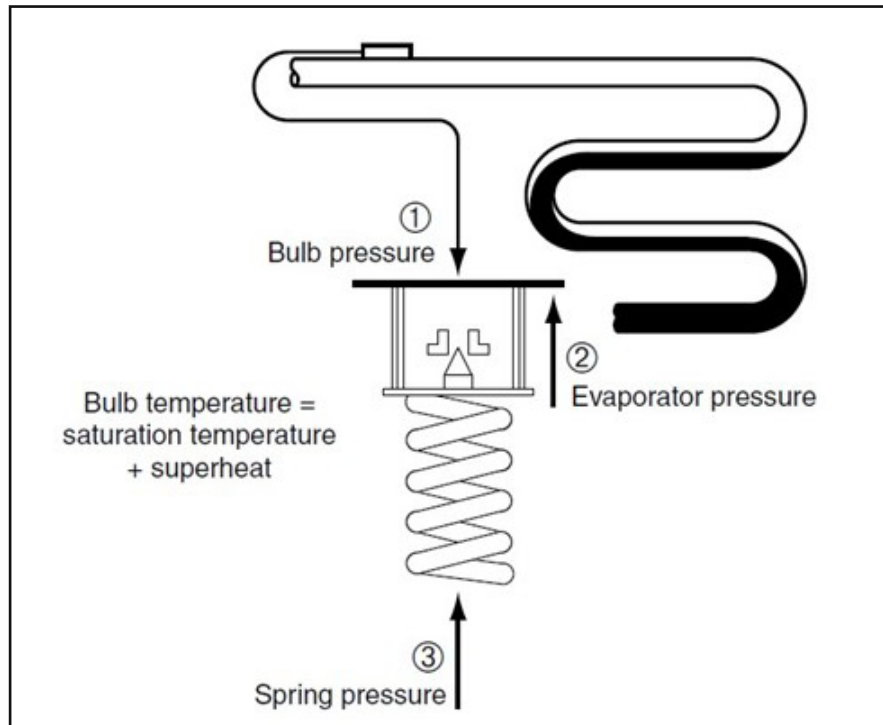


Fig. 6B.14 TXV 3 Pressures

### 6B.14.1 Three Pressures

There are three pressures at work on a TXV:

- (1) The bulb pressure which is the only opening force.
- (2) The evaporator pressure which is a closing force.
- (3) The spring pressure which is a closing force.

All the TXV's used in Traulsen TS-Series models are internally equalized, which means that the evaporator pressure closing force is applied internally from the inlet evaporator. The spring pressure is technically adjustable, but it should not be necessary to adjust any TXV on Traulsen equipment- as the superheat will be properly adjusted by Traulsen.

### 6B.14.2 Non-Bleed Type

The TXV used in Traulsen TS-Series equipment is a non-bleed (hard shut-off) type of TXV, which means that the pressures do not equalize during the off-cycle.

### 6B.14.3 Maximum Operating Pressure

The TXV used in a Traulsen TS-Series equipment is a MOP valve with Maximum Operating Pressure. The MOP valve is designed to limit the suction pressure from rising above the MOP value. Therefore, you will never see the suction pressure rise above the MOP value- not even during a hot pull down or after a defrost cycle.

#### 6B.14.4 Measuring Superheat

When troubleshooting a TXV, it may become necessary to measure superheat- this can be done without connecting pressure gauges. All Traulsen TS-Series refrigeration systems are sealed without access for pressure test. Installing pressure test access valves should be the last resort. Superheat can be measured with two thermometers securely attached to refrigerant lines.

(T1) Measure the temperature at the inlet of the evaporator coil after the TXV valve body.

(T2) Measure the temperature at the outlet of the evaporator coil after the TXV sensing bulb.

Subtracting (T1) from (T2) will equal the superheat. The superheat should measure somewhere between 4° to 12° F.

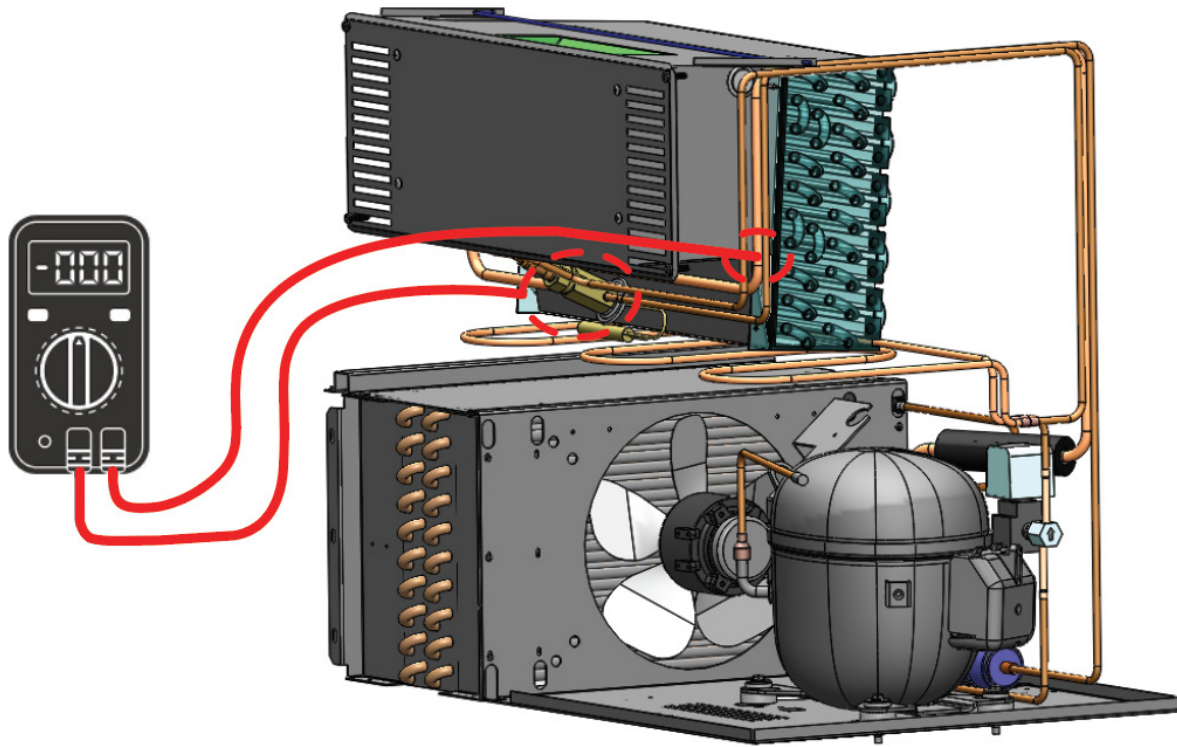


Fig. 6B.14.4 Measuring Superheat

#### 6B.14.5 Restrictions

If the flow of refrigerant becomes restricted at the TXV, the valve will be very cold to the point of freezing, but the evaporator coil will be warm with high superheat and subcooling. Both low side and high side pressures will drop. Although, if refrigerant is added to the system, the high side pressure will rise but the low side will not.

#### 6B.14.6 Replacing the TXV

If it becomes necessary to replace the TXV, care should be taken to replace it with the exact OEM part. When brazing the TXV into the system, care should be taken not to overheat the valve. This is best accomplished by wrapping the valve with a cold wet rag. A dry nitrogen purge of 10 SCFH should be used to displace the oxygen to prevent the creation of an oxidized film inside the piping- which could lead to system contamination or a restriction. Too much nitrogen pressure will blow back through the joint and cause pinholes. After replacing the TXV, be sure to pull a deep vacuum of 200 microns.

## 6B.15 Servicing the Refrigeration System

### 6B.15.1 Condenser Assembly

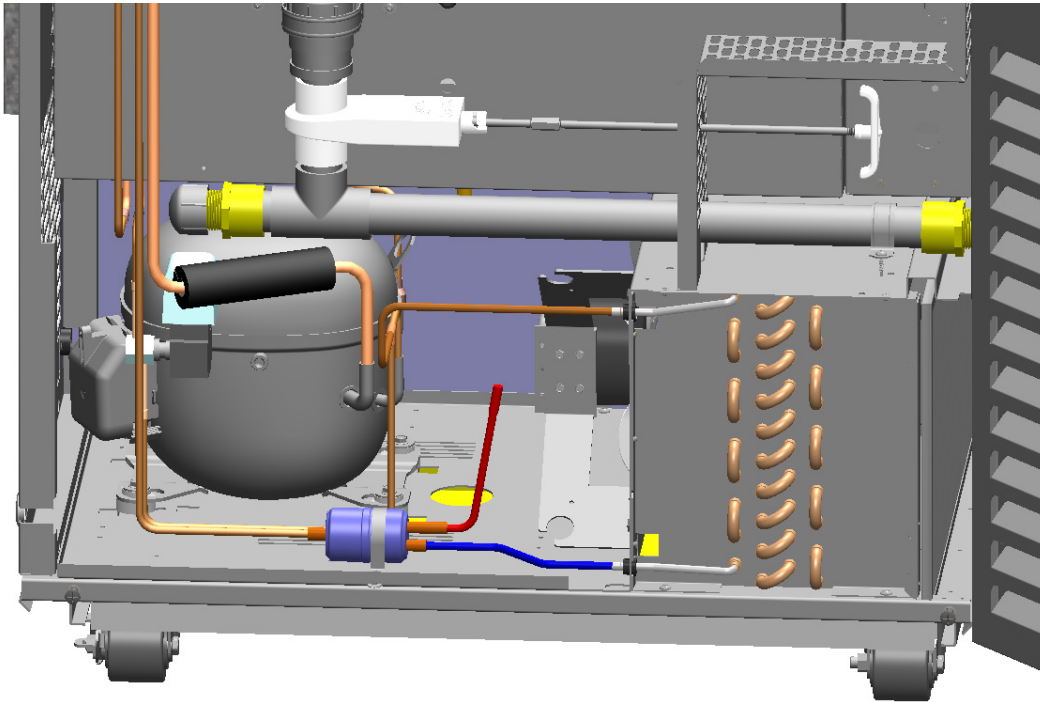


Fig. 6B.15.1 Condenser Assembly

### 6B.15.2 Defrost Troubleshooting- in TS models

Traulsen uses 1 type of defrost on the TS-Series refrigerators. The last cabinet temperature before the defrost started will be displayed throughout the entire defrost cycle.

#### Hot Gas Defrost

During a **hot gas defrost cycle**, the LAE control sends 120V to the solenoid valve (**Purple wire**) to activate the defrost process. This defrost method works by using the hot refrigerant gas from the compressor discharge line to melt frost or ice buildup on the evaporator coil, instead of using electric heaters.

**Activation of Solenoid:** When the control detects that defrost is needed ( based on time), it sends 120V to the hot gas solenoid valve. This energizes the solenoid, allowing hot refrigerant gas to flow into the evaporator.

**Hot Gas Flow:** The solenoid directs the hot gas (normally sent to the condenser during cooling) into the evaporator. The hot gas moves through the evaporator coil, which heats the coil surface and melts the accumulated frost or ice.

**Defrost Cycle:** The hot gas remains in the evaporator for a set duration, controlled by the LAE control. This ensures the complete melting of ice and water evaporation which prevents excess moisture from freezing in the system. The termination temperature when the evaporator coil reaches 55 deg (blue sensor)

**Return to Cooling:** Once defrost is complete, the LAE control deactivates the solenoid by cutting off the 120V signal, and the system switches back to normal refrigeration operation.

**Hot gas defrost** is efficient because it utilizes the existing refrigerant system to generate heat, rather than relying on additional electrical heating elements, reducing energy consumption.



Fig. 6B.15.2b Defrost Icon

### 6B 15.3 Troubleshooting Guide for Solenoid Valve (Hot Gas Defrost)

#### Check for Defrost Mode

Confirm that the display indicates a defrost cycle by checking if the defrost icon (DEF) is lit.

#### Verify Voltage to the Solenoid Coil:

Using a multimeter, measure the voltage at the solenoid coil terminals. Ensure the voltage matches the system specifications. If no voltage is present, trace the wiring back to the control board and power source to identify any electrical issues.

#### Manually Open the Solenoid Valve:

Use a solenoid magnet to force the plunger open. This allows you to bypass any electrical issues temporarily and confirm that the valve itself is functioning mechanically.

#### Temperature Sensing:

Check the temperature on the copper tubing before and after the solenoid valve using a contact thermometer or an infrared thermometer.

If the solenoid valve opens correctly, there should be a noticeable temperature change downstream (after the valve). This indicates that hot gas is flowing through the system as expected.

#### Diagnose Based on Findings:

If the solenoid operates correctly when forced open but fails under normal operation, investigate the electrical control circuit further.

If no temperature change is detected, this could indicate a mechanical failure of the solenoid valve or a blockage in the line. This process ensures both electrical and mechanical integrity of the hot gas defrost solenoid valve.

## 6B.16 Service Parts List

Item	Description	Part Number
<b>CASTERS</b>	<b>All Models</b>	
	6" ADJUSTABLE CASTER NO LOCK	<a href="#">SER-60538-00</a>
	6" ADJUSTABLE CASTER WITH LOCK	<a href="#">SER-60538-01</a>
	4 5/8" ADJUSTABLE CASTER NO LOCK	<a href="#">SER-60536-00</a>
	4 5/8" ADJUSTABLE CASTER WITH LOCK	<a href="#">SER-60536-01</a>
	3 1/2" ADJUSTABLE CASTER NO LOCK	<a href="#">SER-60567-00</a>
	3 1/2" ADJUSTABLE CASTER WITH LOCK	<a href="#">SER-60567-01</a>
<b>LEGS</b>	<b>ALL MODELS</b>	
	6" LEG	<a href="#">SER-60542-00</a>
<b>DOORS</b>	<b>MODELS TS048 &amp; TS072 (right section)</b>	
	DOOR ASSEMBLY, HINGED LEFT	<a href="#">200-60791-00</a>
	DOOR ASSEMBLY, HINGED RIGHT	<a href="#">200-60791-01</a>
	DOOR GASKET	<a href="#">341-60197-00</a>
<b>DOORS</b>	<b>MODELS TS066, TS072 &amp; TS090 (left section)</b>	
	DOOR ASSEMBLY, HINGED LEFT	<a href="#">200-60789-00</a>
	DOOR ASSEMBLY, HINGED RIGHT	<a href="#">200-60789-01</a>
	DOOR GASKET	<a href="#">341-60197-02</a>
<b>DRAWERS</b>	<b>2 DRAWER 6" DEEP PAN MODELS TS048 &amp; TS072 (right section)</b>	
	DRAWER ASSEMBLY	<a href="#">550-10108-00</a>
	DRAWER FACE ASSEMBLY	<a href="#">550-10114-00</a>
	DRAWER FRAME ASSEMBLY	<a href="#">550-10104-00</a>
	DRAWER FRAME INSERT	<a href="#">SER-60539-00</a>
	DRAWER GASKET	<a href="#">341-60176-07</a>
	DRAWER ROLLER	<a href="#">344-60155-00</a>
	DRAWER ADAPTER BAR	<a href="#">701-61198-00</a>
<b>DRAWERS</b>	<b>2 DRAWER 6" DEEP PAN MODELS TS066, TS072 &amp; TS090 (LEFT SECTION)</b>	
	DRAWER ASSEMBLY	<a href="#">550-10190-00</a>
	DRAWER FACE ASSEMBLY	<a href="#">550-10194-00</a>
	DRAWER FRAME ASSEMBLY	<a href="#">550-10188-00</a>
	DRAWER FRAME INSERT	<a href="#">SER-60568-00</a>
	DRAWER GASKET	<a href="#">341-60176-09</a>
	DRAWER ROLLER	<a href="#">344-60155-00</a>
	DRAWER ADAPTER BAR	<a href="#">701-61258-00</a>
<b>DRAWERS</b>	<b>3 DRAWER 4" DEEP PAN MODELS TS048 &amp; TS072 (RIGHT SECTION)</b>	
	DRAWER ASSEMBLY	<a href="#">550-10098-00</a>
	DRAWER FACE ASSEMBLY	<a href="#">550-10099-00</a>
	DRAWER FRAME ASEMBLY	<a href="#">550-10104-00</a>
	DRAWER FRAME INSERT	<a href="#">SER-60541-00</a>
	DRAWER GASKET	<a href="#">341-60176-06</a>
	DRAWER ROLLER	<a href="#">344-60155-00</a>
	DRAWER ADAPTER BAR	<a href="#">701-61198-00</a>

## 6B.16 Service Parts List (CONT'D)

Item	Description	Part Number
<b>DRAWERS</b>	<b>3 DRAWER 4" DEEP PAN MODELS TS066, TS072 &amp; TS090 (left section)</b>	
	DRAWER ASSEMBLY	550-10191-00
	DRAWER FACE ASSEMBLY	<a href="#">550-10196-00</a>
	DRAWER FRAME ASEMBLY	550-10188-00
	DRAWER FRAME INSERT	SER-60569-00
	DRAWER GASKET	<a href="#">341-60176-10</a>
	DRAWER ROLLER	<a href="#">344-60155-00</a>
	DRAWER ADAPTER BAR	<a href="#">701-61258-00</a>
<b>KEY</b>	<b>DOOR LOCKS (all models)</b>	
	Key	<a href="#">346-28924-42</a>
<b>SHELVES</b>	<b>MODEL TS048 (3 shelves maximum per door)</b>	
	SHELF PLATED	<a href="#">340-60230-01</a>
	MODEL TS066	
	SHELF PLATED LEFT SECTION	<a href="#">340-60294-00</a>
	SHELF PLATED RIGHT SECTION	<a href="#">340-60294-01</a>
	MODEL TS072	
	SHELF PLATED LEFT SECTION	<a href="#">340-60294-00</a>
	SHELF PLATED RIGHT SECTION	<a href="#">340-60231-03</a>
	MODEL TS090	
	SHELF PLATED LEFT SECTION	<a href="#">340-60294-00</a>
	SHELF PLATED RIGHT SECTION	<a href="#">340-60294-01</a>
	SHELF PLATED CENTER SECTION	<a href="#">340-60295-00</a>
<b>SHELF MOUNTING PINS</b>	<b>ALL MODELS</b>	
	SHELF PIN	<a href="#">344-24759-02</a>
<b>RAIL COVERS</b>	<b>MODEL TS048</b>	
	HINGED LIFT UP LID	500-60722-00
	MODEL TS066	
	HINGED LIFT UP LID	500-60722-01
	MODEL TS072	
	HINGED LIFT UP LID	500-60722-02
	MODEL TS090	
	HINGED LIFT UP LID	500-60722-03
<b>RAIL AIR BAFFLES</b>	<b>MODEL TS048</b>	
	AIR BAFFLE BACK	<a href="#">614-60254-00</a>
	AIR BAFFLE FRONT	<a href="#">614-60254-01</a>
	1/4-20 THUMB SCREW & RETAINING RING	SER-60570-00
	MODEL TS066	
	AIR BAFFLE BACK	<a href="#">614-60252-02</a>
	AIR BAFFLE FRONT	<a href="#">614-60252-01</a>
	1/4-20 THUMB SCREW & RETAINING RING	SER-60570-00

## 6B.16 Service Parts List (CONT'D)

Item	Description	Part Number
<b>RAIL AIR BAFFLES</b>	<b>MODEL TS072</b>	
	AIR BAFFLE BACK	614-60257-00
	AIR BAFFLE FRONT	614-60257-01
	1/4-20 THUMB SCREW & RETAINING RING	SER-60570-00
	<b>MODEL TS090</b>	
	AIR BAFFLE BACK	614-60250-02
	AIR BAFFLE FRONT	614-60250-01
	1/4-20 THUMB SCREW & RETAINING RING	SER-60570-00
<b>RAIL ADAPTER BARS</b>	<b>MODELS TS048 &amp; TS090 (models only)</b>	
	ADAPTER BAR	701-61444-00
<b>LOUVERS</b>	<b>ALL MODELS</b>	
	LOUVER PANEL	500-60729-00
<b>FILTERS</b>	<b>MODELS TS048</b>	
	FILTER	341-60062-05
	MODELS TS066, TS072 & TS090	
	FILTER	341-60062-07
<b>WHITE PLASTIC CUTTING BOARDS</b>	<b>MODELS TS048 &amp; TS072</b>	
	WHITE PLASTIC CUTTING BOARD	340-60172-00
	MODEL TS066	
	WHITE PLASTIC CUTTING BOARD	340-60172-02
	MODEL TS090	
	WHITE PLASTIC CUTTING BOARD	340-60172-06
<b>COMPOSITE CUTTING BOARDS</b>	<b>MODELS TS048 &amp; TS072</b>	
	COMPOSITE CUTTING BOARD	340-60171-01
	MODELS TS066	
	COMPOSITE CUTTING BOARD	340-60171-03
	MODELS TS090	
	COMPOSITE CUTTING BOARD	340-60171-02
<b>WICKING CARD KIT</b>	<b>ALL MODELS</b>	
	WICKING CARD KIT	SER-60571-00



## 8. Warranty Information

### NOTES STANDARD DOMESTIC WARRANTY

TRAULSEN & CO., INC. Warrants new equipment to the original purchaser, when installed within the United States against defective material and workmanship for one (1) year from the date of original installation. Under this warranty, TRAULSEN & CO., INC. Will repair or replace, at its option, including service and labor, all parts found to be defective and subject to this warranty. The compressor part is warranted for an additional four (4) years. During this period TRAULSEN & CO., INC. Will supply replacement compressor(s) if deemed defective, however, all installation, recharging and repair costs will remain the responsibility of the owner.

This warranty does not apply to damage resulting from fire, water, burglary, accident, abuse, misuse, transit, acts of God, attempted repairs, improper installation by unauthorized persons, and will not apply to food loss.

THERE ARE NO ORAL, STATUTORY OR IMPLIED WARRANTIES APPLICABLE TO TRAULSEN, INCLUDING BUT NOT LIMITED TO, ANY IMPLIED WARRANTY OF MERCHANTABILITY OR FITNESS FOR ANY PARTICULAR PURPOSE WHICH EXTEND BEYOND THE DESCRIPTION ON THE FACE HEREOF. TRAULSEN SHALL HAVE NO OBLIGATION OR LIABILITY FOR CONSEQUENTIAL OR SPECIAL DAMAGES, GROWING OUT OF OR WITH RESPECT TO THE EQUIPMENT OR ITS SALE, OPERATION OR USE, AND TRAULSEN NEITHER ASSUMES NOR AUTHORIZES ANYONE ELSE TO ASSUME FOR IT ANY OBLIGATION OR LIABILITY IN CONNECTION WITH THE EQUIPMENT OR ITS SALE, OPERATION OR USE OTHER THAN AS STATED HEREIN.

### INTERNATIONAL COMMERCIAL WARRANTY

(for Canadian warranties see domestic US warranty)

TRAULSEN & CO., INC. Warrants to the original purchaser the Refrigeration Equipment manufactured and sold by it to be free from defects in material and workmanship under normal use and service for a period of one (1) year from date of shipment. Under this warranty, TRAULSEN & CO., INC. Will reimburse the purchaser for the replacement of any part of said equipment (excluding dryers & refrigerant gas) which then proves to be defective. This warranty is void if said equipment or any part thereof has been subject to misuse, damage in transit, accident, negligence or alteration.

TRAULSEN'S standard warranty does not apply to Export Sales. Rather, for a period of one (1) year from date of original installation not to exceed Fifteen (15) months from date of shipment from factory, TRAULSEN:

will replace, F.O.B. factory, any defective parts normally subject to warranty.

will not cover the cost of packing, freight or labor such costs being the sole responsibility of the dealer.

THIS WARRANTY IS IN LIEU OF ALL OTHER WARRANTIES EITHER EXPRESSED OR IMPLIED AND CONSTITUTES TRAULSEN'S FULL OBLIGATION AND LIABILITY. WARRANTIES NOT AVAILABLE ON REMOTE MODELS.

## NOTES:



4401 Blue Mound Road Fort Worth, Texas 76106 (USA)  
Phone: 800.825.8220 | E-mail: [service@traulsen.com](mailto:service@traulsen.com) | Website: [traulsen.com](http://traulsen.com)  
Form Number: TR00410 | Revision Date: 8-2024

Hours of Operation: Monday - Friday 7:30 a.m. - 4:30 p.m. (CST)