



Traulsen Refrigeration

SERVICE MANUAL

Instructions For The Troubleshooting And Repair Of Traulsen Full-Size Undercounter Refrigerators and Freezers

**TU044HT, TU072HT & TU100HT Refrigerator Models
TU044LT & TU072LT Freezer Models**



This manual is prepared for the use of trained Authorized Traulsen Service Agents and should not be used by those not properly qualified. This manual is not intended to be all encompassing, but is written to supplement the formal training, on-the-job experience and other product knowledge acquired by Authorized Traulsen Service Agents. Before proceeding with any work, you should read, in its entirety, the repair procedure you wish to perform to determine if you have the necessary tools, instruments and skills required to perform the procedure. Only a trained Authorized Traulsen Service Agent should perform procedures for which you do not have the necessary tools, instruments and skills. Reproduction or other use of this manual without the express written consent of Traulsen, is prohibited.

TABLE OF CONTENTS

I. THE SERIAL TAG	Page 1	V. CONDENSER FAN MOTOR OR BLADE	Page 4
II. GENERAL INFORMATION	Page 2	VI. CONDENSER COIL	Page 5
a-Introduction	Page 2	VII. EVAPORATOR FAN	Page 5
b-Model Designations	Page 2	VIII. COMPRESSOR	Page 6
c-Wiring Diagram	Page 2	IX. WIRING DIAGRAM	Page 7
d-Installation	Page 2	X. SERVICE PROCEDURES & ADJUSTMENTS	
e-Cleaning	Page 2	a-System Access	Page 8
f-Tool Requirements	Page 2	b-Sweat-On Piercing Valves	Page 8
g-Refrigeration System-Theory of Operation	Page 2	c-Refrigerant Leak Check	Page 8
h-Air Flow Requirements	Page 2	d-Evacuating System	Page 8
i-The Microprocessor Control	Page 3	e-Charging System	Page 9
j-Control Location	Page 3	f-System Clean Up/Introduction	Page 9
k-Operating Data Chart-Refrigerator	Page 3	g-Heater Test-Drawer Perimeter Heater	Page 10
l-Operating Data Chart-Freezer	Page 3	XI. ELECTRICAL OPERATION	Page 10
m-Specifications-Refrigerator	Page 3	a-Normal Operation	Page 10
n-Specifications-Freezer	Page 3	b-Defrost Mode	Page 10
III. SERVICE ACCESS		c-Component Function	Page 10
a-System	Page 3	d-Installation Of The Sensors	Page 11
b-Evaporator Housing Cover	Page 4	XII. TROUBLESHOOTING	Page 12
c-Accessing Start Components	Page 4	XIII. SERVICE PARTS LIST	Page 13
IV. RE-HINGE DOOR(S)	Page 4	XIV. SERVICE ASSISTANCE	Page 14

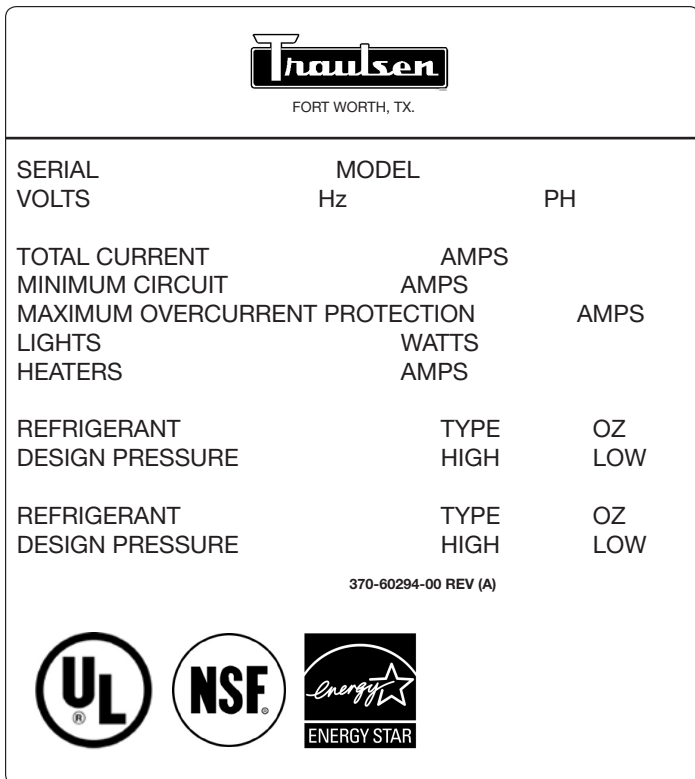

Figure 1

I. THE SERIAL TAG

The serial tag is a permanently affixed label on which is recorded vital electrical and refrigeration data about your Traulsen product, as well as the model and serial number. This tag is located in the right interior compartment on all standard TU Series Full-Size Undercounter models. See Figure 1.

READING THE SERIAL TAG

- Serial = The permanent ID# of your Traulsen unit
- Model = The model # of your Traulsen unit
- Volts = Voltage
- Hz = Cycle
- PH = Phase
- Total Current = Maximum amp draw
- Minimum Circuit = Minimum circuit ampacity
- Lights = Light wattage
- Heaters = Heater amperage (Hot Food units only)
- Refrigerant = Refrigerant type used
- Design Pressure = High & low side operating pressures and refrigerant charge
- Agency Labels = Designates agency listings

II. GENERAL INFORMATION

II. a-INTRODUCTION:

This manual applies to the following models only:

TU Series Full-Size Undercounter Refrigerators
TU044HT, TU072HT & TU100HT

TU Series Full-Size Undercounter Freezers
TU044LT & TU072LT

II. b-MODEL DESIGNATIONS:

	<u>TU 044 HT</u>		
Positions	<u>1</u>	<u>2</u>	<u>3</u>
Position 1:	TU = Traulsen Undercounter		
Position 2:	044 = 44" Length Model	072 = 72" Length Model	100 = 100" Length Model
Position 3:	HT=Refrigerator LT=Freezer		

II. c-WIRING DIAGRAM:

Refer to the wiring diagram for any service work performed on this unit. A copy is placed on the unit when shipped. Also, a copy of the wiring diagram is located on page 7 of this manual. Should you require another copy, or a wiring diagram for an older production unit, please contact Traulsen Service at (800) 825-8220. You should have model and serial number of unit prior to calling. See page 1 for serial tag location and information.

II. d-INSTALLATION:

Generally TU Series Full Size Undercounter refrigerators and freezer units are installed by the dealer, or other parties contracted by the dealer or owner. Detailed installation instructions are included along with each unit when shipped.

II. e-CLEANING:

Detailed cleaning instructions are included with each unit, however special care **MUST** be given to the condenser coil. The condenser coil must be cleaned at a minimum of every six months. This can be done with a vacuum cleaner using a brush attachment, or a stiff brush or whisk broom. For more information on cleaning, please refer to the Owner's Manual.

II. f-TOOL REQUIREMENTS:

For most jobs a standard set of hand tools, a VOM and AC current tester, along with a temperature tester or thermometer are adequate tools. However, in some cases the following additional tools may be required as well:

II. f-TOOL REQUIREMENTS (cont'd):

- Refrigeration Gauge Manifold
- Refrigeration Reclaiming Equipment
- Acetylene Torch
- Anti-Static Grounding Kit (TL 84919)
- Nitrogen Bottle With Gauges
- Thin 5/16" Open End Wrench
- Refrigerant Reclaim Unit

II. g-REFRIGERATION SYSTEM-THEORY OF OPERATION:

The refrigeration system is the mechanism whereby heat is transferred from the cabinet to the outside air. It works under the principle that the heat moves from hot to cold as it tries to establish equilibrium.

The microprocessor control signals a need for heat to be removed from the cabinet. The compressor begins by compressing the refrigerant gas as it is discharged. The high pressure refrigerant now circulates through the condenser, removing heat from the refrigerant and condensing it into a liquid. From there the refrigerant flows to the filter drier which removes all traces of moisture and particles from the system.

After the filter drier, the refrigerant passes through a "metering device". Traulsen uses a thermostatic expansion valve to regulate the flow of refrigerant into the evaporator coils.

In the evaporator coil, heat is transferred from the cabinet to the refrigerant, which changed from a cold liquid to a warm low pressure gas. When the desired cabinet air temperature has been reached, the microprocessor control shuts off the compressor. See figure 2.

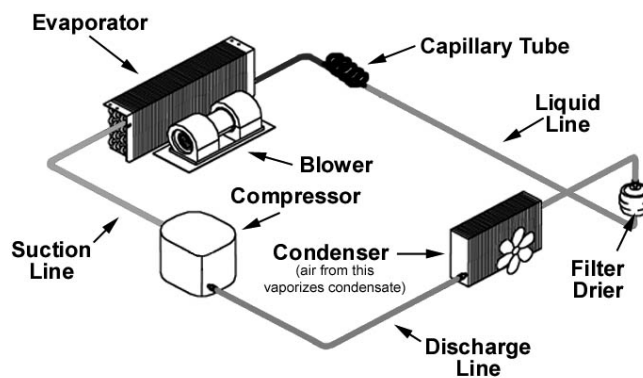

Figure 2

II. h-AIR FLOW REQUIREMENTS:

To assure optimum performance, the condensing unit of your Traulsen unit **MUST** have an adequate supply of air for cooling purposes. Therefore, the operating location must allow a minimum of 12" clearance in front of the louvers to allow for unrestricted air flow to the condensing unit.

II. GENERAL INFORMATION (cont'd)

II. i-THE MICROPROCESSOR CONTROL:

For detailed information on replacement, repair or adjustment of the INTELA-TRAUL® microprocessor control please refer to it's manual, form number TR35705 or contact our Service Department at 800-825-8220.

II. j-CONTROL LOCATION:

On all TU Series Full Size Undercounter models, the microprocessor control is located on the louver assembly, right above the Traulsen nameplate. The louver/refrigeration system are mounted standard on the left side, but as an option are available on the right side as well. See figure 3.

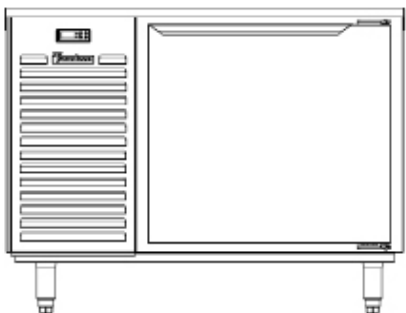

Figure 3

II. k-OPERATING DATA CHART-REFRIGERATOR:

Ambient	70°F	100°F
Suction Pressure	35 PSIG	50 PSIG
Suction Temperature	3°F	16°F
Discharge Pressure	200 PSIG	295 PSIG
Discharge Temperature	88°F	115°F

II. l-OPERATING DATA CHART-FREEZER:

Ambient	70°F	100°F
Suction Pressure	15 PSIG	17 PSIG
Suction Temperature	-22°F	-19°F
Discharge Pressure	200 PSIG	265 PSIG
Discharge Temperature	88°F	107°F

II. m-SPECIFICATIONS-REFRIGERATOR:

	TU044HT	TU072HT	TU100HT
HP	1/3	1/3	1/3
Condensing Unit BTU/HR	2440	2440	2440
Cabinet Amp Draw	6.3	6.3	6.3
Refrigerant	R-404a	R-404a	R-404a
Refrigerant Charge (oz.)	19	19	19

II. n-SPECIFICATIONS-FREEZER:

	TU044LT	TU072LT
HP	1/2	1/2
Condensing Unit BTU/HR	1970	1970
Cabinet Amp Draw	8.0	8.0
Refrigerant	R-404a	R-404a
Refrigerant Charge (oz.)	18	18

III. SERVICE ACCESS

III. a-SYSTEM:

To remove the louver assembly first place your hands under the louver panel and lift this up off the bracket and then away from the cabinet face. **NOTE:** Figure below shown with optional refrigerator drawers.

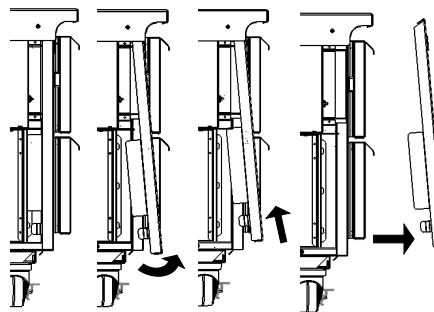

Figure 4

III. SERVICE ACCESS (cont'd)

III. a-SYSTEM(cont'd):

To gain full access to the refrigeration system from the side, remove the side cover by removing the screws.

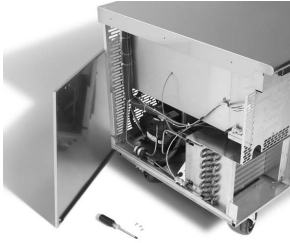

Illustration III. 1

When finished, place the louver assembly back into position and replace the side panel. Secure these in place using the previously removed screws.

III. b-EVAPORATOR HOUSING COVER:

If the unit is supplied with a marine work top, first remove the work top by removing the mounting screws on the left and right side of the work top. Next, remove the #3 Phillips head screws from the top of the evaporator and cabinet space cover.

NOTE: The cover is sealed with RTV which may need to be scored before removing the cover.

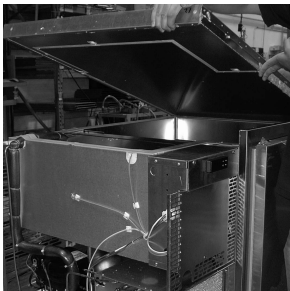

Illustration III. 2

Reverse the procedure when done, to reinstall.

III. c-ACCESSING START COMPONENTS:

The start components are mounted on the compressor. To access the start components, first remove the louver assembly and side panel as instructed in section III. a. The start components are mounted on the back side of the compressor.

IV. RE-HINGE DOOR(S)

IV. a-DOOR RE-HINGE INSTRUCTIONS:

Your Traulsen Full Size Undercounter model door(s) are field re-hingeable. If re-hinging is required, please contact our Service Department at 800-825-8220 for re-hinge instructions.

V. CONDENSER FAN MOTOR OR BLADE

V. a-REPLACEMENT INSTRUCTIONS:

▲WARNING Disconnect the electrical power to the machine and follow lockout/tag out procedures.

Step 1: Remove the louver assembly as outlined in section III. a. To gain access through left side.

Step 2: Remove the screws holding the fan motor bracket to the compressor mounting base (see Illustration V.1).

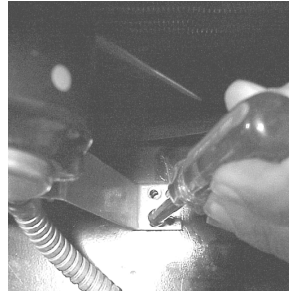

Illustration V. 1

Step 3: Remove the blade from the motor shaft by removing the nut (see Illustration V. 2).

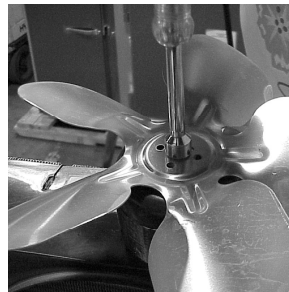

Illustration V. 2

NOTE: Install the concave side of the fan blade toward the motor. If the blade is all that is being replaced, stop here and reverse procedure to install.

Step 4: Remove the mounting bracket from the motor (see Illustration V. 3).



Illustration V. 3

Step 5: Disconnect lead wires at the compressor junction box.

Step 6: Reverse the procedure to install.

Step 7: Reconnect power to the unit.

VI. CONDENSER COIL

VI. a-REPLACEMENT INSTRUCTIONS:

⚠ WARNING Disconnect the electrical power to the machine and follow lockout/tag out procedures.

⚠ WARNING This procedure requires the use of refrigerants, be certain the work area is well ventilated. Safety goggles and gloves shall be worn since refrigerants may cause burns to the skin.

Step 1: Remove the louver assembly as outlined in section III. a.

Step 2: Recover the refrigerant in the system following the current EPA Guidelines for refrigerant recovery.

NOTE: The use of reclaiming equipment is required.

Step 3: Disconnect the input and output lines to the condenser coil at the soldered joints closest to the condenser.

Step 4: Remove the four (4) screws which secure the condenser coil to the mounting brackets (see Illustration VI. 1).

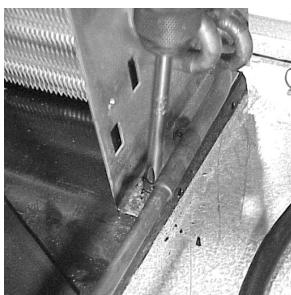

Illustration VI. 1

Step 5: Remove the condenser coil.

Step 6: Reverse the procedure to install the new condenser coil.

Step 7: Install a new drier.

Step 8: Charge the refrigeration system as outlined under "CHARGING SYSTEM" in "SERVICE PROCEDURES AND ADJUSTMENTS".

Step 9: Reconnect power to the unit.

Step 10: Reset the microprocessor control defrost time settings to the correct time of the day.

VII. EVAPORATOR FAN

VII. a-REPLACEMENT INSTRUCTIONS:

⚠ WARNING Disconnect the electrical power to the machine and follow lockout/tag out procedures.

See section III. b. for removal of evaporator housing cover.

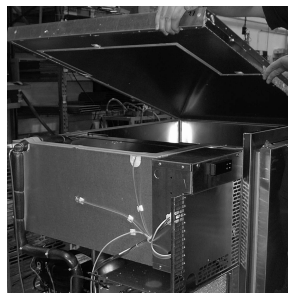

Illustration VII. 1

Remove the steel evaporator fan assembly retaining pin from the evaporator housing.



Illustration VII. 2

Remove evaporator fan housing mounting screws to allow for removal of entire evaporator fan motor assembly.

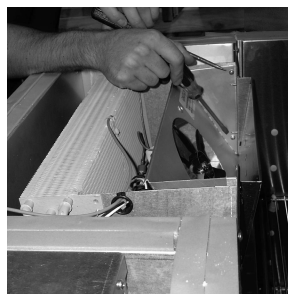

Illustration VII. 3

Disconnect electrical.

VIII. COMPRESSOR

VIII. a-COMPRESSOR:

▲ WARNING Disconnect the electrical power to the machine and follow lockout/tag out procedures.

▲ WARNING This procedure requires the use of re-frigerants, be certain the work area is well ventilated. Safety goggles and gloves shall be worn since refrigerants may cause burns to the skin.

NOTE: Compressor models will vary with each cabinet model, but the basic removal instructions can be followed.

Step 1: Recover the refrigerant in the system following the current EPA Guidelines for refrigerant recovery.

NOTE: The use of reclaiming equipment is required.

Step 2: Remove the compressor junction box cover.

Step 3: Disconnect all wire leads coming into the junction box.

Step 4: Disconnect the discharge and suction lines to the compressor (see Illustration VII. 1).

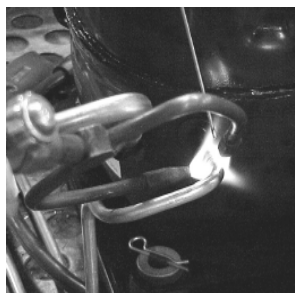

Illustration VII. 1

Step 5: Remove the compressor which is secured by either four (4) nuts or pins.

Step 6: Install the new compressor and connect the input and output lines.

Step 7: Connect the lead wires at the junction box.

Step 8: Install a new drier.

Step 9: Charge the refrigeration system as outlined under "CHARGING SYSTEM" in "SERVICE PROCEDURES AND ADJUSTMENTS."

Step 10: Reconnect power to the unit.

Step 11: Reset the microprocessor control defrost time settings to the correct time of day.

IX. WIRING DIAGRAM

NOTE: Refer to the wiring diagram below (applies to refrigerators and freezers units) for any service work performed by a qualified technician.

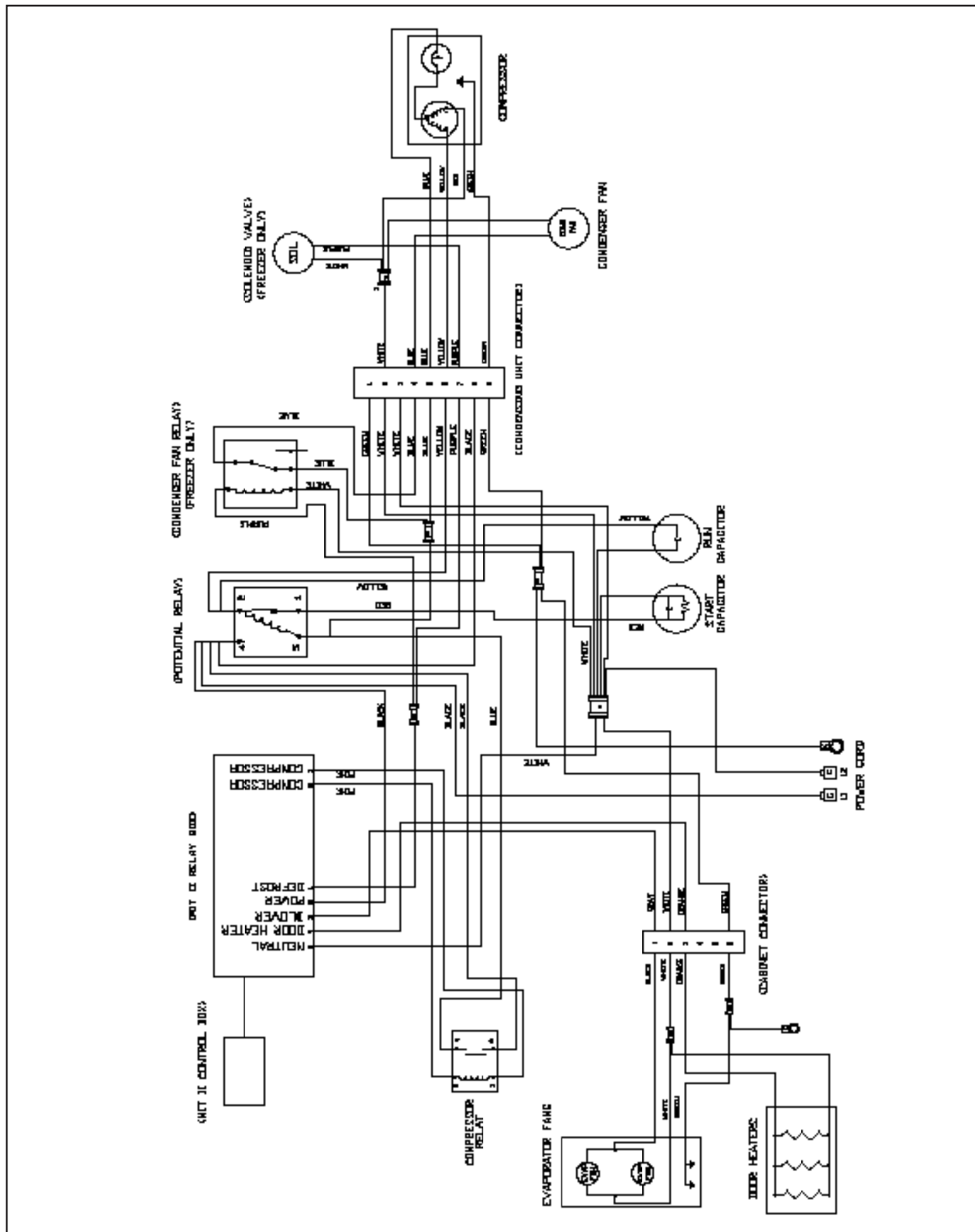

X. SERVICE PROCEDURES & ADJUSTMENTS

⚠ WARNING Certain procedures in this section require electrical test or measurements while power is applied to the machine. Exercise extreme caution at all times. If test points are not easily accessible, disconnect power, attach test equipment and reapply power to test.

X. a-SYSTEM ACCESS:

All external indicators should be checked as part of system diagnosis before determining the refrigerant pressures. Improper access may expose the refrigerant to contaminants and non-condensables which will result in system failure.

X. b-SWEAT-ON PIERCING VALVES:

NOTE: Sweat-on piercing valves are used for system diagnostics, but may be left on after service is complete. They may be installed while the system is fully charged.

1) Place one piercing valve on the compressor process tube and one on the liquid line process tube. Follow the installation instructions provided by the manufacturer of the piercing valve.

2) When complete, follow the guidelines as outlined under "REFRIGERATION LEAK CHECK" and "EVACUATING SYSTEM."

X. c-REFRIGERANT LEAK CHECK:

⚠ WARNING Disconnect the electrical power to the machine at the main circuit box. Place a tag on the circuit box indicating the circuit is being serviced.

⚠ WARNING This procedure requires the use of refrigerants, be certain the work area is well ventilated. Safety goggles and gloves shall be worn since refrigerants may cause burns to the skin.

NOTE: The use of R-22 in small quantities is Recommended as a trace gas for leak detection.

NOTE: This leak check procedure is to be used only after the refrigerant has been properly reclaimed.

1) Access the refrigeration system (note: see section III. a).

2) Attach gauge manifold set to the system, low side to process tube on the compressor and the high side to the process tube.

3) Connect refrigerant bottle to the center of gauge manifold and open the valve on the bottle. Bleed charging hose at the manifold gauge to remove air from the system.

4) Open valve on low side of gauge manifold and charge system with one ounce of R-22.

5) Close low side valve on gauge manifold and the valve on the refrigerant bottle.

6) Disconnect refrigerant bottle and connect nitrogen bottle.

X. c-REFRIGERANT LEAK CHECK (cont'd):

NOTE: The use of a nitrogen regulator is required.

7) Set output valve on nitrogen valve to 120 psi.

8) Open nitrogen bottle valve and low side gauge manifold valve. Allow pressure to equalize.

9) Shut off both valves and disconnect nitrogen bottle.

10) Use a leak detector or a thick soapy solution and check for leaks at all tubing connections.

A - If leaks are found, repair leaks and repeat process.

B - If no leaks are found, evacuate system as outlined in section "X. d - EVACUATING SYSTEM").

11) Charge the system by weighing in the exact charge and check for proper operation.

X. d-EVACUATING SYSTEM:

Introduction - Refrigeration reclaiming equipment is required. Our goal in system evacuation is to remove all the non-condensables possible. No evacuation method will remove 100% of the moisture and air from within the refrigeration circuit. Because of this, guidelines and methods must be developed and adhered to ensuring only harmless amounts of contaminants remain in the system.

GUIDELINES

⚠ WARNING Do not pressurize system above 150 PSIG, prior to evacuation or during leak test procedures.

- Use only a two stage vacuum pump (2 CFM or greater) and electronic micron.
- Evacuate from high and low sides of the system.
- No chemical additive or alcohols are to be used to "dry up" a system.
- Blow down of system with DRY NITROGEN prior to evacuation is acceptable and many times desirable. See "System Clean-Up." See page 9.
- Evacuate to 200 microns.

PROCEDURE

⚠ WARNING Disconnect the electrical power to the machine at the main circuit box. Place a tag on the circuit box indicating the circuit is being serviced.

⚠ WARNING This procedure requires the use of refrigerants, be certain the work area is well ventilated. Safety goggles and gloves shall be worn since refrigerants may cause burns to the skin.

X. SERVICE PROCEDURES & ADJUSTMENTS (cont'd)

⚠ WARNING Certain procedures in this section require electrical test or measurements while power is applied to the machine. Exercise extreme caution at all times. If test points are not easily accessible, disconnect power, attach test equipment and reapply power to test.

X. d-EVACUATING SYSTEM(cont'd):

- 1) Access the refrigeration system as outlined under "SYSTEM ACCESS."
- 2) Connect low (blue) side of gauge manifold to schrader valve on compressor process line and high (red) side of gauge manifold to schrader valve on filter/drier process line.
- 3) Connect center line of gauge manifold to vacuum pump.
- 4) Turn vacuum pump on and open both sides of gauge manifold.
- 5) Pull a vacuum to 200 microns.
- 6) Break the vacuum with 3 psig of dry nitrogen.
- 7) Repeat steps 5 and 6.
- 8) Pull vacuum to 200 microns.
- 9) Charge system and check for proper operation.

X. e-CHARGING SYSTEM:

⚠ WARNING Disconnect the electrical power to the machine at the main circuit box. Place a tag on the circuit box indicating the circuit is being serviced.

⚠ WARNING This procedure requires the use of refrigerants, be certain the work area is well ventilated. Safety goggles and gloves shall be worn since refrigerants may cause burns to the skin.

- 1) Access the refrigeration system.
- 2) Attach gauge manifold set to system, low side to process tube on the compressor and the high side to the process tube on the drier.

NOTE: See "SYSTEM ACCESS."

- 3) Be sure the system is properly leak checked and evacuated before charging as outlined under "LEAK CHECK" and "EVACUATING SYSTEM."

- 4) Make certain both valves are closed on the gauge manifold. Open the valve on the bottle. Bleed charging hose at the manifold gauge to remove air.

NOTE: Initially charge system through high side to prevent liquid refrigerant from reaching compressor.

- 5) Open the high side gauge valve (red). Allow refrigerant to flow into the system until the nameplate charge is reached or until the high side will not accept any more refrigerant. At this point, shut the gauge and bottle valves.

- 6) Reconnect power to the unit and check for proper operation and high pressure leaks.

X. e-CHARGING SYSTEM (cont'd):

- 7) Add the remaining amount of refrigeration charge through the low side with the compressor running.
- 8) Check for proper operation and leaks.
- 9) Disconnect power to the unit and replace any covers removed.

X. f-SYSTEM CLEAN UP/INTRODUCTION:

When a compressor burn-out or moisture infiltration is encountered, the service person must make the determination as to the degree of system contamination. Normally a compressor burn-out will fit into one of three categories:

- CONTAINED - compressor oil not acidic, no oil discoloration.
- CONTAMINATED COMPRESSOR - oil acidic, discoloration of oil, contamination limited to compressor.
- MASSIVE CONTAMINATION - contaminated oil and/or refrigerant pumped through system.

CONTAINED

- 1) Replacement of liquid line drier.
- 2) Install suction filter drier for clean up and then remove it when service is complete. Usually within 48-hours.
- 3) Replacement of compressor.
- 4) Evacuation (to 200 microns).
- 5) Charge by weight.

CONTAMINATED COMPRESSOR

The "contaminated compressor" requires the same procedure as the "contained" burn-out. Plus, the system must be flushed with nitrogen after the compressor and drier has been removed.

X. PROCEDURES & ADJ. (cont'd)

▲WARNING Certain procedures in this section require electrical test or measurements while power is applied to the machine. Exercise extreme caution at all times. If test points are not easily accessible, disconnect power, attach test equipment and reapply power to test.

X. f-SYSTEM CLEAN UP/INTRODUCTION MASSIVE CONTAMINATION (cont'd):

NOTE: The replacement compressor MUST NOT be installed until after system clean-up procedures have been completed.

- 1) Remove the burned-out compressor as outlined under "COMPRESSOR".
- 2) Remove the capillary tube metering device.
- 3) Purge nitrogen through the high and low sides of system until moisture and contaminated oil has been removed from the remaining components of the system.
- 4) Reassemble refrigeration system and add a CW style liquid drier and a suction line drier.
- 5) Purge nitrogen through the high and low sides of system for 5 minutes.
- 6) Evacuate refrigeration as outlined under "EVACUATING SYSTEM" for 30 minutes. Repeat nitrogen purge and evacuate two more times.
- 7) Charge system as outlined under "CHARGING SYSTEM". Allow for the increased liquid capacity of the liquid line drier.
- 8) Reconnect power and check for proper operation.
- 9) Disconnect power and install any panels removed.
- 10) Return between 24 and 48 hours to recover gas, replace liquid line drier with a CW style drier. Remove the suction drier, but do not replace.
- 11) Evacuate and charge system as outlined under "EVACUATING SYSTEM" and "CHARGING SYSTEM".

X. g-HEATER TEST-DRAWER PERIMETER HEATER:

- 1) Access the orange heater power wire connected to terminal #4 of the relay module.
- 2) Plug the unit in and verify 120vac supply to heater from the orange heater power wire.
- 3) Check for nominal amp draw (.25-.5 amps).
- 4) Disconnect power, check for continuity using an Ohm meter from the orange heater wire to neutral.

XI. ELECTRICAL OPERATION

XI. a-NORMAL OPERATION:

1. Conditions
 - a) Unit connected to correct voltage (check using a volt meter).
 - b) Microprocessor off cycle defrost settings correct.
 - c) Condensing unit controlled by the microprocessor control.
 - d) Cabinet at desired temperature.
 - e) Door perimeter heaters are powered 100% of the time as pre-set by the factory (this can be adjusted using the microprocessor control).
 - f) Evaporator fan powered.
 - g) Microprocessor control operating correctly.
2. Cabinet temperature rises above set temperature.
 - a) Microprocessor control initiates compressor operation.
 - b) Evaporator fan should be ON all the time.
3. Set temperature is met.
 - a) Conditions return to those outlined in step 1.

XI. b-DEFROST MODE:

1. Conditions
 - a) Unit operating in normal mode.
2. Defrost is initiated by the microprocessor control (an off-cycle defrost should occur every 60 minutes for refrigerators or a hot gas defrost every 4 hours for freezers).
3. Defrost terminated by either: 1) Evaporator Coil Temperature or 2) Maximum Set Time Interval.
4. Cabinet returns to normal operation.
 - a) Temperature controlled by the microprocessor control.
 - b) Evaporator fan stays ON, evaporator coil will reach desired temperature.

XI. ELECTRICAL OPERATION (cont'd)

XI. c-COMPONENT FUNCTION:

COMPONENT	FUNCTION
1. Compressor	Pumps refrigerant thru refrigeration system components and compresses the low pressure vapor into high pressure vapor.
2. Evaporator Fan	Draws air across condenser coil to aid in removing heat from the refrigerant and moves air across compressor to aid in cooling the compressor.
3. Start Capacitor	Stores electrical charge which helps start the compressor motor.
4. Run Capacitor	Helps keep the compressor motor running after starting.
5. Microprocessor Control	Performs the functions of the 1) defrost timer, 2) high limit switch, 3) thermometer and 4) thermostat.
6. Drawer Perimeter Heater	Heats drawer opening to prevent condensation from forming.
7. Contactor Relay	Controls voltage to compressor motors.

XI. d-INSTALLATION OF THE SENSORS:

There are two sensors used inside the cabinet. The first one is the Cabinet Sensor that is used to cycle the compressor on and off at the correct temperature. The cabinet sensor is mounted through the wall of the evaporator housing on the return side of the evaporator.

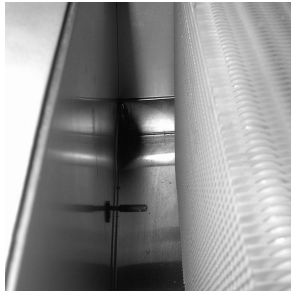

Illustration XI. 1

The third sensor used is a Liquid Line Sensor. This sensor is to be installed on the liquid line as it comes out of the condenser coil. The part number for this sensor is [337-60407-01](#).

When the condensing temperature reaches 140°F or greater the control will display “CLN-FIL.” Should the condensing temperature increase to 160°F the compressor will automatically shut off. When the liquid line temperature drops below 140°F the compressor will restart and when the line temperature drops to 120°F the alarm will reset.

The Evaporator Coil Sensor is to be mounted in the evaporator, in the center of the coil and fully inserted into the coil until only the wire is visible and then pinch the fins around the cable to hold it in place. The part number for the Evaporator Coil Sensor is [337-60406-02](#).



Illustration XI. 2

XII. TROUBLESHOOTING

▲ WARNING Certain procedures in this section require electrical and refrigeration system test or measurements while power is applied to the machine, exercise extreme caution at all times. If test points are not easily accessible, disconnect power, attach test equipment and reapply power to test.

PROBLEM	POSSIBLE SOLUTION
Compressor will not run, compressor has no current draw.	<ol style="list-style-type: none"> 1. Main circuit breaker open. 2. Compressor overload tripped. 3. Cabinet temperature satisfied. 4. Wired wrong or faulty connection. 5. INTELA-TRAUL® control malfunction. 6. Start component malfunction. 7. Compressor motor windings open.
Compressor will not run, current draw and trips overload.	<ol style="list-style-type: none"> 1. Low voltage. 2. Start component malfunction. 3. Compressor windings shorted. 4. Locked rotor. 5. Excessive discharge pressure.
Compressor short cycles on overload.	<ol style="list-style-type: none"> 1. Low voltage. 2. Low refrigerant charge. 3. Dirty condenser coil and/or filter. 4. Wired wrong or faulty connection. 5. Condenser fan inoperative. 6. Run capacitor malfunction. 7. Start component malfunction. 8. INTELA-TRAUL® control malfunction. 9. High head pressure.
Compressor short cycles.	<ol style="list-style-type: none"> 1. Improper air flow over evaporator coil. 2. Low ambient conditions. 3. INTELA-TRAUL® control malfunction. 4. Bad sensors. 5. Temp differential set too close.
Continuous unit operation.	<ol style="list-style-type: none"> 1. Loss of refrigerant. 2. Excessive drawer openings. 3. INTELA-TRAUL® control malfunction. 4. Broken compressor valves. 5. Very dirty condenser and/or filter. 6. Check the "DL," if higher than 160F.
Compressor run time lengthy.	<ol style="list-style-type: none"> 1. Partial loss of refrigerant. 2. High ambient conditions. 3. Dirty condenser coil or improper air flow over.
Condenser coil.	<ol style="list-style-type: none"> 1. Excessive product load. 2. Excessive drawer openings. 3. Drawer gasket requires replacement. 4. INTELA-TRAUL® control malfunction. 5. Contaminates in refrigeration system. 6. Compressor valve leakage. 7. Inadequate defrost cycle.
Low suction pressure.	<ol style="list-style-type: none"> 1. Capillary tube restricted. 2. Drier plugged. 3. Loss of refrigerant. 4. Poor air flow. 5. Iced evaporator coil.
High head pressure.	<ol style="list-style-type: none"> 1. Improper air flow across condenser. 2. High ambient conditions. 3. Overcharge of refrigerant. 4. Air in system. 5. Dirty condenser coil.
Will not defrost or inadequate defrost.	<ol style="list-style-type: none"> 1. Defrost heater malfunction. 2. Wired wrong or faulty connection. 3. Cabinet air leak. 4. Coil sensor failure. 5. INTELA-TRAUL® control malfunction¹.
Coil icing.	<ol style="list-style-type: none"> 1. Number of defrost cycles too few. 2. Defrost duration too short. 3. Cabinet air leak. 4. Drain tube plugged. 5. Defrost heater not working. 6. Non-frozen product put into cabinet. 7. Coil sensor failure.
The cabinet & coil sensors show high temperature.	<ol style="list-style-type: none"> 1. Sensor needs replacing (place sensor tip and thermometer in ice water. Change sensor ir readings differ, or if sensor displays -40 02 266)

XIII. SERVICE PARTS LIST

NOTE: Part numbers listed are for standard products as currently manufactured. For products manufactured as other than standard, please contact the factory with model and serial number of unit in question.

ITEM	DESCRIPTION	PART NUMBER
Casters	All Models	
	6" Adjustable - No Lock	SER-60538-00
	6" Adjustable - With Lock	SER-60538-01
Leg	All Models	
	6" Leg	SER-60542-00
Door	All Models	
	Door - Hinges on the Left	200-60593-00
	Door - Hinges on the Right	200-60593-01
	Door Gasket	341-60197-00
Drawer	2 Drawer 6" Deep Pan (refrigerator models only)	
	Drawer Assembly	550-10108-00
	Drawer Face Assembly	550-10114-00
	Drawer Frame Assembly	550-10104-00
	Drawer Frame Insert	SER-60539-00
	Drawer Gasket	341-60176-07
	Drawer Roller	344-60155-00
Drawer	3 Drawer 4" Deep Pan (refrigerator models only)	
	Drawer Assembly	550-10098-00
	Drawer Face Assembly	550-10099-00
	Drawer Frame Assembly	550-10104-00
	Drawer Frame Insert	SER-60541-00
	Drawer Gasket	341-60176-06
	Drawer Roller	344-60155-00
Shelf	Model TU044	
	Shelf Chrome	340-60230-01
Shelf	Model TU072 (2 section) & TU100 (3 section)	
	Shelf Chrome 2 & 3 Section, Left Hand	340-60231-02
	Shelf Chrome 2 & 3 Section, Right Hand	340-60231-03
Shelf	Model TU100 (3 section-center shelf)	
	Shelf Chrome 3 Section, Center	340-60232-01
Louver	All Models	
	Louver Panel	500-70081-00
Microprocessor Control	All Models	
	Control Head	337-60403-00
	Sensor, Cabinet Temperature	337-60405-01
	Sensor, Coil Temperature	337-60406-01
	Sensor, Liquid Line Temperature	337-60407-01
	Relay Module	337-60317-00

XIV. SERVICE ASSISTANCE

XIV. a-SERVICE INFORMATION:

NOTE: Before calling for service, please check the following:

Is the electrical cord plugged in?

Is the fuse OK or circuit breaker on?

Clean condenser coil

Is the power switch on?

Reset microprocessor control values to factory defaults.

If after checking the above items and the unit is still not operating properly, please contact an authorized Traulsen service agent. A complete list of authorized service agents was provided along with your Traulsen unit. If you cannot locate this, you may also obtain the name of a service agent from the Tech Service page of our website: www.traulsen.com. If service is not satisfactory, please contact our in-house service department at:

Traulsen
4401 Blue Mound Road
Fort Worth, TX 76106
(800) 825-8220

NOTE: Traulsen reserves the right to change specifications or discontinue models without notice.

XIV. b-SPARE PARTS INFORMATION:

To purchase replacement parts or to speak to service support for Traulsen and most Hobart Refrigeration units please contact our Ft. Worth facility by phone at 800-825-8220 or fax to 817-740-6748 (parts) or 817-740-6757 (service).

To source parts locally follow instructions below for nearest location:

1. Log onto www.traulsen.com
2. Select Service Directory (top of screen)
3. Select Locate Parts (left side of screen)
4. Click on State desired

To source service support locally follow instructions below for nearest authorized service agent:

1. Log onto www.traulsen.com
2. Select Service Directory (top of screen)
4. Click on State desired

NOTE: When calling for spare parts or service support, please make sure you have model and serial number of unit available.

XIV. c-WARRANTY REGISTRATION:

The warranties for your new Traulsen unit may be registered with us by contacting our Ft. Worth facility by phone at 800-825-8220 or you may register on line:

1. Log onto www.traulsen.com
2. Select Service Directory (top of screen)
3. Select Warranty Registration Form (left side of screen)
4. Fill out information requested
5. Select Submit to complete unit warranty registration

HOURS OF OPERATION:

Monday thru Friday 7:30 am - 4:30 pm CST



Quality Refrigeration

Traulsen

4401 Blue Moud Road Fort Worth, TX 76106

Phone (800) 825-8220 Fax (817) 740-6757

Website: www.traulsen.com