

# USER GUIDE

SAFETY • INSTALLATION & INTEGRATION • OPERATING INSTRUCTIONS • MAINTENANCE • **SERVICE**

## Parts

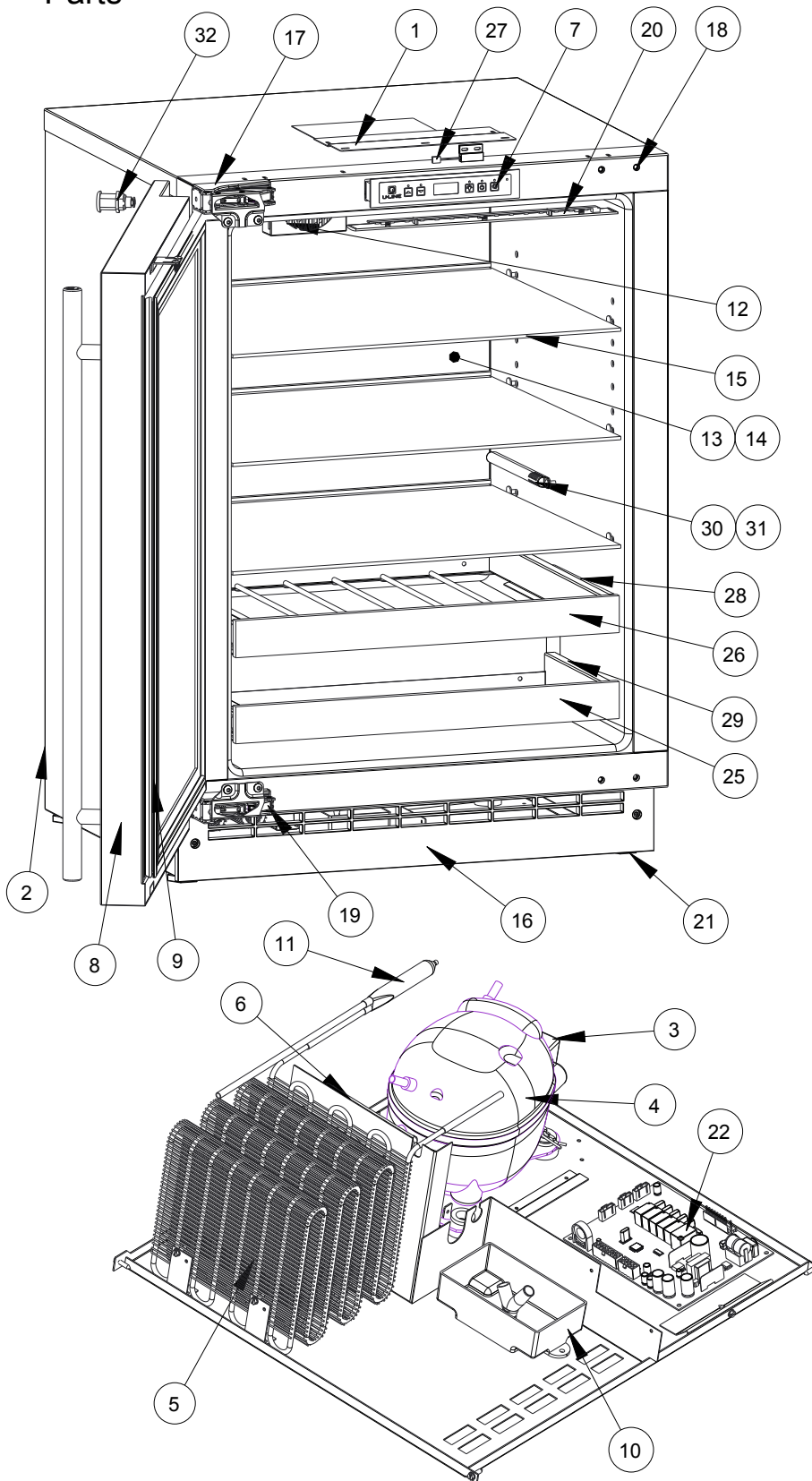

U-2224BEVS-15B		
Item	Description	U-Line P/N
1	Anti tip brackets w/screws	<a href="#">80-54012-00</a>
2	Back panel	<a href="#">80-54086-00</a>
3	Compressor electricals only	<a href="#">80-54149-00</a>
4	Compressor w/electricals	<a href="#">80-54150-00</a>
5	Condenser	<a href="#">80-54043-00</a>
6	Condenser fan w/screws	<a href="#">80-54014-00</a>
7	Display module	<a href="#">80-54007-00</a>
8	Door assembly w/ hinges	<a href="#">80-54162-00</a>
9	Door gasket	<a href="#">80-54039-00</a>
10	Drain pan w/double sided tape	<a href="#">80-54002-00</a>
11	Drier	<a href="#">80-54055-00</a>
12	Evap fan w/cover and screws	<a href="#">80-54151-00</a>
13	Evaporator	<a href="#">80-54057-00</a>
14	Evaporator cover	<a href="#">80-54042-00</a>
15	Glass shelf (1) w/clips	<a href="#">80-54041-00</a>
16	Grille w/ screws	<a href="#">80-54040-00</a>
17	Hinge covers (2 pcs)	<a href="#">80-54001-00</a>
18	Hinge mounting hole covers	<a href="#">80-54024-00</a>
19	Hinges(2) w/screws and covers	<a href="#">80-54013-00</a>
20	LED light strip and cover assy	<a href="#">80-54000-00</a>
21	Leg Levelers (4)	<a href="#">80-54019-00</a>
22	Main board (no wires or case)	<a href="#">80-54008-00</a>
23	Packaging	<a href="#">80-54159-00</a>
24	Power cord	<a href="#">80-54171-00</a>
25	Rack assembly, bottom	<a href="#">80-54091-00</a>
26	Rack assembly, top	<a href="#">80-54010-00</a>
27	Reed switch	<a href="#">80-54134-00</a>
28	Slide assembly, long	<a href="#">80-54047-00</a>
29	Slide assembly, Short	<a href="#">80-54048-00</a>
30	Thermistor (1 piece)	<a href="#">80-54006-00</a>
31	Thermistor cover and pin	<a href="#">80-54023-00</a>
32	Universal lock assembly	<a href="#">80-54153-00</a>