

QUICK START GUIDE



DISPENSERS • CDE224E (115v) • 4 Tap Mixed

WELCOME TO U-LINE

Congratulations on your U-Line purchase. Your product comes from a company with over five decades of premium modular ice making, refrigeration, and wine preservation experience. U-Line creates products focused on functionality, style, and inspired innovations — paying close attention to even the smallest details. Applications include residential, outdoor, ADA height compliant, marine, and commercial. Complete product categories include Beverage Centers, Wine Refrigerators, Ice Machines, Refrigerators, Freezers, and Dispensers.

Our advanced refrigeration systems, large and flexible capacities, and Built-In to Stand Out® clean integrated look allow you to preserve the right product, in the right place, at the right temperature. Since 2014, U-Line has been part of the Middleby family of brands. All products are designed, engineered, and assembled in Milwaukee, Wisconsin, USA, and select products are available worldwide. U-Line - RIGHT PRODUCT. RIGHT PLACE. RIGHT TEMPERATURE®.

PRODUCT INFORMATION

Looking for additional information on your product? User Guides, Spec Sheets, CAD Drawings, Compliance Documentation, and Product Warranty information are all available for reference and download at u-line.com.

PROPERTY DAMAGE / INJURY CONCERNS

In the unlikely event property damage or personal injury is suspected related to a U-Line product, please take the following steps:

1. U-Line Customer Care must be contacted immediately at +1.414.354.0300.
2. Service or repairs performed on the unit without prior written approval from U-Line is not permitted. If the unit has been altered or repaired in the field without prior written approval from U-Line, claims will not be eligible.

GENERAL INQUIRIES

U-Line Corporation
8900 N. 55th Street
Milwaukee, Wisconsin 53223 USA
Monday - Friday 8:00 am to 4:30 pm CST
T: +1.414.354.0300
Email: sales@u-line.com
u-line.com

SERVICE & PARTS ASSISTANCE

Monday - Friday 8:00 am to 4:30 pm CST
T: +1.414.354.0300
Service Email: onlineservice@u-line.com
Parts Email: onlineparts@u-line.com

CONNECT WITH US



Designed, engineered and assembled in WI, USA

This Quick Start Guide covers the basics of installation and general use of your product.

CONTENTS

Safety and Warning	4
Environmental Requirements	5
Electrical	5
Door Swing	5
Door Adjustments	6
General Installation	8
Control Operation	18
Airflow & Product Loading	18
First Use	18
Cleaning	20
Warranty	25

For more details, see the complete User Guide & Service Manual on u-line.com.

Safety and Warning

NOTICE

Please read all instructions before installing, operating, or servicing the appliance.

Use this appliance for its intended purpose only and follow these general precautions with those listed throughout this guide:

SAFETY ALERT DEFINITIONS

Throughout this guide are safety items labeled with a Danger, Warning, or Caution based on the risk type:

DANGER

Danger means that failure to follow this safety statement will result in severe personal injury or death.

WARNING

Warning means that failure to follow this safety statement could result in serious personal injury or death.

CAUTION

Caution means that failure to follow this safety statement may result in minor or moderate personal injury, property, or equipment damage.

DANGER

This unit contains R600a (Isobutane) which is a flammable hydrocarbon. It is safe for regular use. Do not use sharp objects to expedite defrosting. Do not service without consulting the “R600a specifications” section included in the User Guide. Do not damage the refrigerant circuit.

DANGER

Service must be done by factory authorized service personnel. Any parts shall be replaced with like components. Failure to comply could increase the risk of possible ignition due to incorrect parts or improper service.

WARNING

CALIFORNIA PROPOSITION 65

This product contains chemicals known to the state of California to cause cancer and birth defects or other reproductive harm.

www.P65warnings.CA.gov

CAUTION

This equipment is to be installed with adequate backflow protection to comply with applicable federal, state and local codes.

CAUTION

This equipment is intended for the storage and display of packaged products only.

If this refrigerator has a glass door, it is a display refrigerator. Please see caution statement below:

CAUTION

This display refrigerator is not for the display of potentially hazardous foods.

Environmental Requirements

This model is intended for indoor/interior applications only and is not to be used in installations that are open/exposed to natural elements.

This unit is designed to operate between 50°F (10°C) and 100°F (38°C). Higher ambient temperatures may reduce the unit's ability to reach low temperatures and/or reduce ice production on applicable models.

For best performance, keep the unit out of direct sunlight and away from heat generating equipment.

In climates where high humidity and dew points are present, condensation may appear on outside surfaces. This is considered normal. The condensation will evaporate when the humidity drops.



Damages caused by ambient temperatures of 40°F (4°C) or below are not covered by the warranty.

Electrical

SHOCK HAZARD — Electrical Grounding Required. Never attempt to repair or perform maintenance on the unit until the electricity has been disconnected.

Never remove the round grounding prong from the plug and never use a two-prong grounding adapter.

Altering, cutting or removing power cord, removing power plug, or direct wiring can cause serious injury, fire, loss of property and/or life, and will void the warranty.

Never use an extension cord to connect power to the unit.

Always keep your working area dry.

NOTICE

Electrical installation must observe all state and local codes. This unit requires connection to a grounded (three-prong), polarized receptacle that has been placed by a qualified electrician.

The unit requires a grounded and polarized 115 VAC, 60 Hz, 15A power supply (normal household current). An individual, properly grounded branch circuit or circuit breaker is recommended. A GFCI (ground fault circuit interrupter) is usually not required for fixed location appliances and is not recommended for your unit because it could be prone to nuisance tripping. However, be sure to consult your local codes.

See CUTOUT & PRODUCT DIMENSIONS for recommended receptacle location.

Door Swing

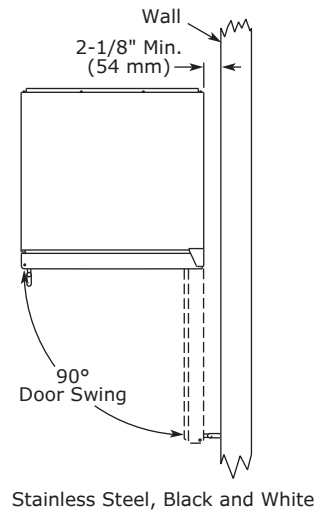

Units have a zero clearance for the door to open 90°, when installed adjacent to cabinets.

Stainless steel models require 2-1/8" (54 mm) door clearance to accommodate the handle if installed next to a wall.

Door Adjustments

HINGE COVER

Hinge cover included with the literature bag is optional.

To install hinge cover:

1. Press hinge cover squarely over hinge.

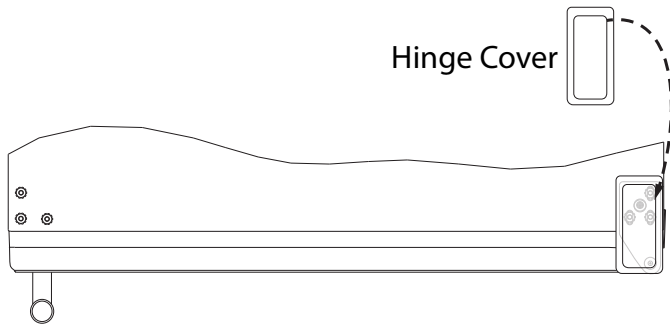

DOOR ALIGNMENT AND ADJUSTMENT

Align and adjust the door if it is not level or is not sealing properly. If the door is not sealed, the unit may not cool properly, or excessive frost may form in the interior.

NOTICE

Properly aligned, the door's gasket should be firmly in contact with the cabinet all the way around the door (no gaps). Carefully examine the door's gasket to ensure that it is firmly in contact with the cabinet. Also make sure the door gasket is not pinched on the hinge side of the door.

To align and adjust the door:

1. Gently pry off hinge cover from top of unit.
2. Loosen (do not remove) top and bottom hinge screws using a Philips screwdriver on the top and a 1/4" socket on the bottom.
3. Align door squarely with cabinet.
4. Make sure gasket is firmly in contact with cabinet all the way around the door (no gaps).
5. Tighten bottom hinge screws.
6. Tighten top hinge screws and replace hinge cover.

REVERSING THE DOOR

Location of the unit may make it desirable to mount the door on the opposite side of the cabinet.

The hinge hardware will be removed and reinstalled on the opposite side of the cabinet.

TO REVERSE THE DOOR

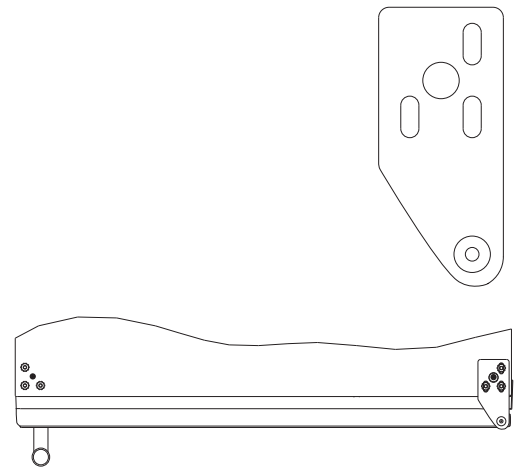

Remove grille:

Remove the grille (see GRILLE INSTALLATION section of this guide).

Remove top hinge and door:

1. Remove hinge cover from top of unit
2. Hold door to keep it from falling.
3. Remove top hinge from cabinet using a Philips screwdriver to remove three screws.

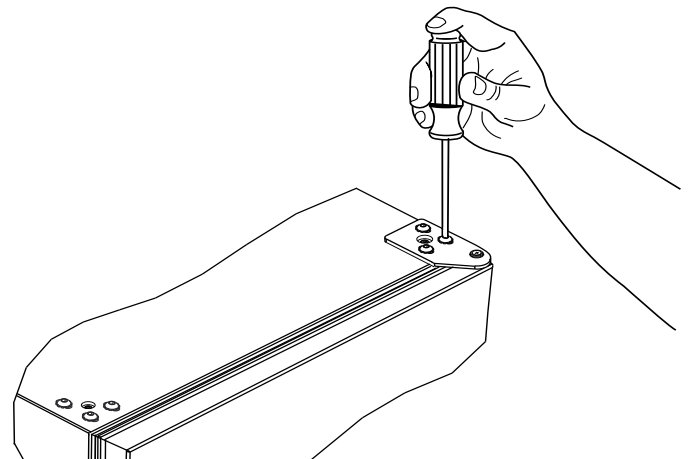

1. Remove door by tilting forward and lifting door off bottom hinge. Retain shoulder washers; they will be reused.
2. Use a Philips screwdriver to remove hinge pin and reinstall on the opposite surface of the hinge.
3. Remove three screws from hinge holes on the opposite side. Reinstall into holes where the hinge was removed. Take care not to scratch cabinet.

Remove bottom hinge:

1. Remove bottom hinge from cabinet using a 1/4" socket.

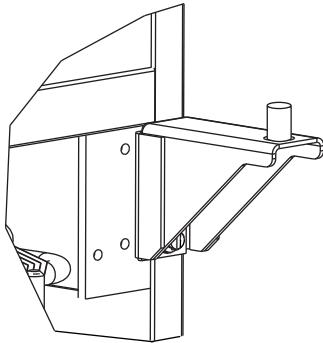

2. Remove corresponding screws on opposite side of cabinet. On some models there may be a nut behind one or both screws on either side.

Install bottom hinge:

Install two or three screws, depending on model. Replace nuts if used.

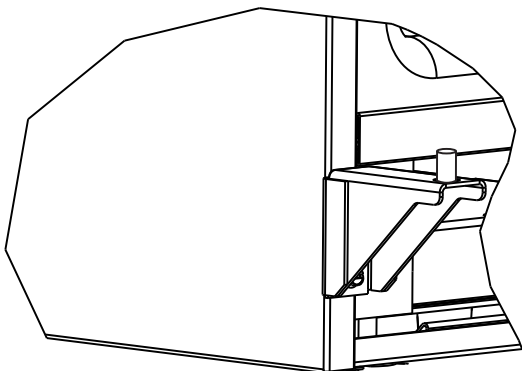

Install top hinge and door:

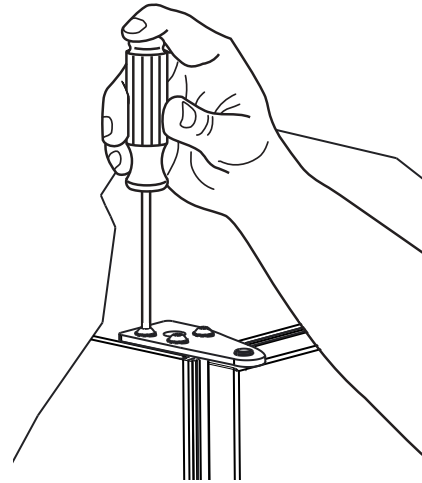

1. Rotate door 180° and lift the door on to the bottom hinge.
2. Install hinge that was used on the opposite side of the unit.
3. Align edge of the hinge with the outer edge of the unit while inserting hinge pin into top of door.
4. Tighten three screws and replace hinge cover.

Align and adjust the door:

Align and adjust the door (see DOOR ALIGNMENT AND ADJUSTMENT)

Install grille

General Installation

The following components are shipped inside the unit:

1. Tap tower (handles, & hardware)
2. Nitrogen hoses (connecting hardware)
3. Infuser regulator (mounting hardware)
4. Liquid jumper line (with in-line filters) and gas jumper line
5. Lo-boy keg couplers
6. CO₂ hoses (connecting hardware)
7. Cleaning solution (2-ounce packet)
(Additional cleaner, ULACOFFEECLEAN, is available at u-line.com)
8. Four casters (2 locking, 2 non-locking)
9. Drip tray
10. Adapter plate & Foam rubber gasket

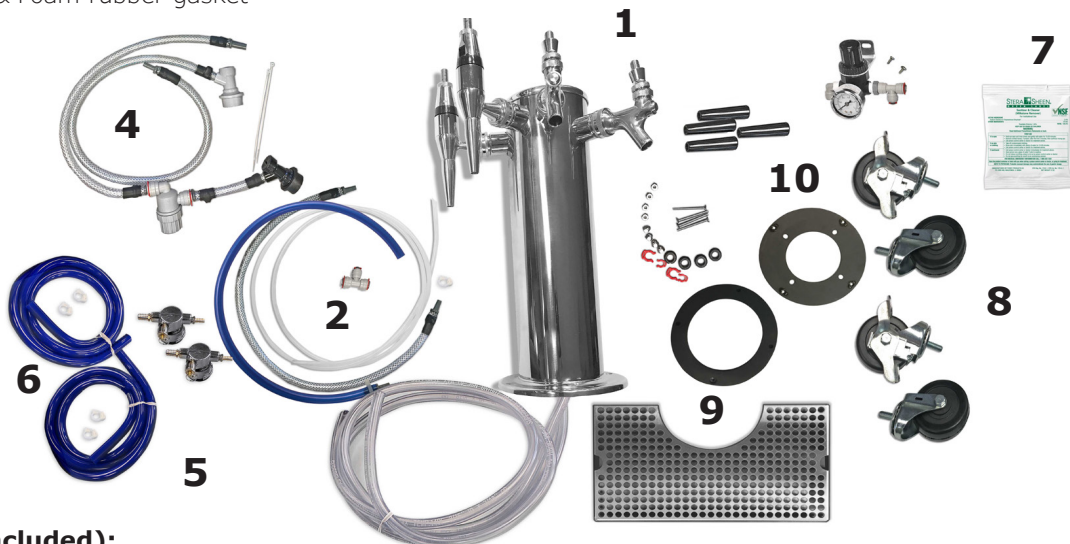

Required (not included):

1. Food grade 5 lb. nitrogen and 5 lb. CO₂ tank - available at your local gas supplier. 22 cubic feet aluminum empty tanks (ULANITROTANK) and nitrogen regulator (ULANITROREG) are available at u-line.com.



Note: If using an external nitrogen source, see CONNECTING EXTERNAL NITROGEN SOURCE section.

2. Food-grade lubricant if connecting to external nitrogen source.

3. 1 ball-tap keg - up to 5 gallons
4. 1 1/4 slim keg
5. 1 1/6 slim keg
6. Your favorite cold coffee or tea and favorite beer, wine, or other beverage.

STANDARD BALL-TAP KEG



Safety and Warning



Keep nitrogen tank in an upright position and handle with care.

Never exceed 60 PSI.

Ventilate area after nitrogen leak.

Connect Hoses to Tower

Your tower comes with two hoses already attached.

1. Attach gas jumper hose - line up and press in firmly.

Note: The connector at the end of the gas jumper line is narrower to correspond with the connection in the tower.



2. Attach liquid jumper hose - line up and press in firmly.

Note: The connector at the end of the liquid jumper line is wider to correspond with the connection in the tower.



Install Tower on Refrigerator

Do not remove all the protective film on the stainless exterior until the tower is installed.

1. Remove four Phillips screws (secured with nuts on the inside of the refrigerator) and lift off cap to reveal tower mounting hole. Peel back enough film for tower to clear.

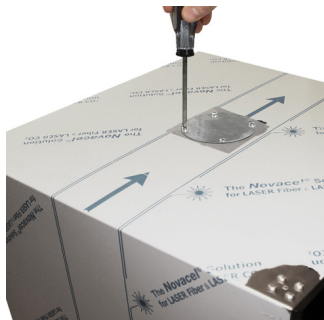

2. Install adapter plate to unit with 4 long screws and nuts (a) then place foam rubber gasket on top - open holes aligned (b).

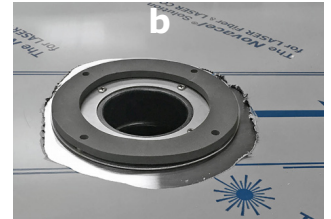
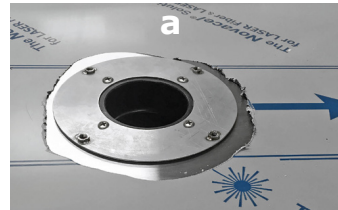

3. Insert all 4 hoses into the opening.



4. Install tower to unit with 4 short Phillips screws.

NOTE: It will be necessary to press down firmly while tightening the screws. Compressing the foam rubber gasket ensures an airtight seal between the unit and the tower.

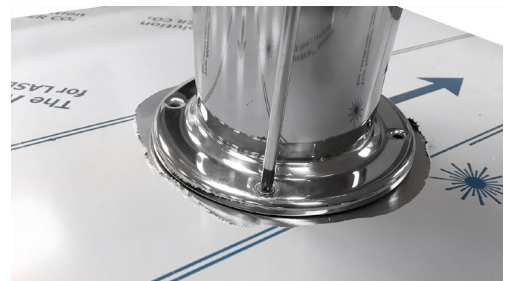

4 Short Screws

Foam Rubber Gasket

4 Long Screws
Adapter Plate

Rubber Gasket
Metal Ring

4 Nuts
4 Acorn Nuts

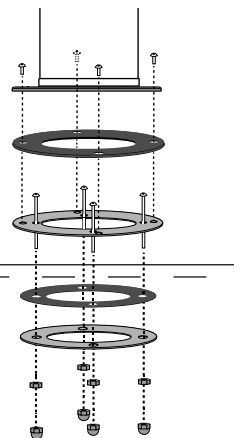

Install Tower on Countertop

(See template on next page)

Note: These instructions are designed for a standard 36" countertop application.

Note: For a customized fit, it may be necessary to acquire screws that are sized to the thickness of your countertop.

1. Position refrigerator under countertop to determine the desired depth.
2. Use the dimensions from Diagram A to determine the center point of the tower mounting hole.
3. Remove refrigerator from under countertop.
4. Use template to drill 4 mounting holes and drill 2-3/4" diameter hole through countertop.
5. If connecting to an external nitrogen and/or CO₂ source, prepare interior of refrigerator (see CONNECT EXTERNAL NITROGEN SOURCE & CONNECT EXTERNAL CO₂ SOURCE) and connect to main source.
6. Remove top cap from refrigerator and carefully slide refrigerator under countertop.
7. Connect nitrogen and liquid lines to tower and feed lines through hole all the way into refrigerator (see CONNECT HOSES TO TOWER).
8. Install adequate insulation between counter top and refrigerator - see Diagram B and note below.
9. Secure tower to countertop.
10. Continue with internal connections.

NOTE: For proper operation of your refrigerator, IT IS NECESSARY to install air-tight insulation between the refrigerator and the tower. The insulation will need to run from the interior of the refrigerator up into the interior of the tower.

Diagram A

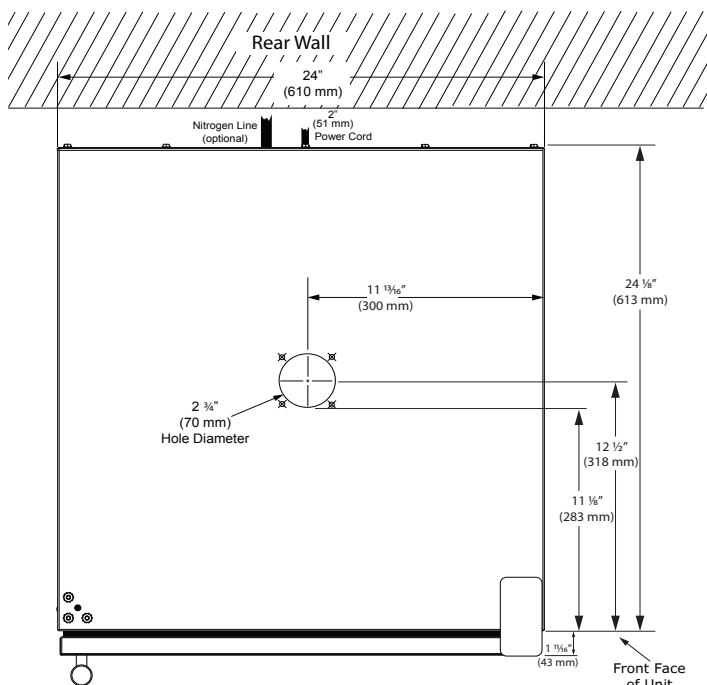
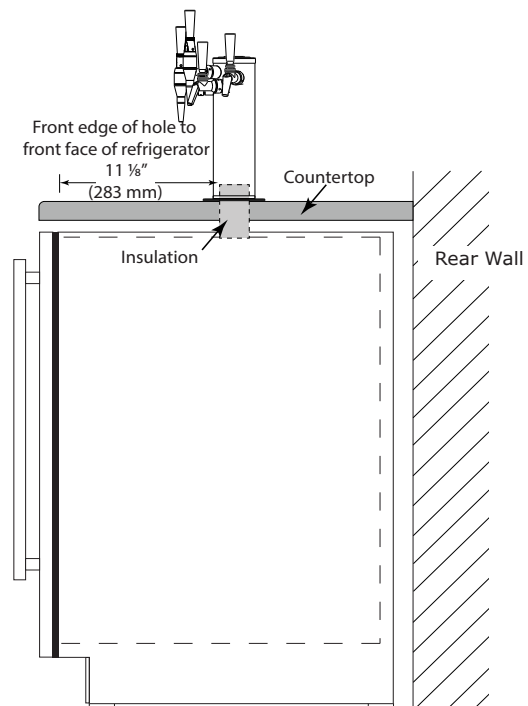
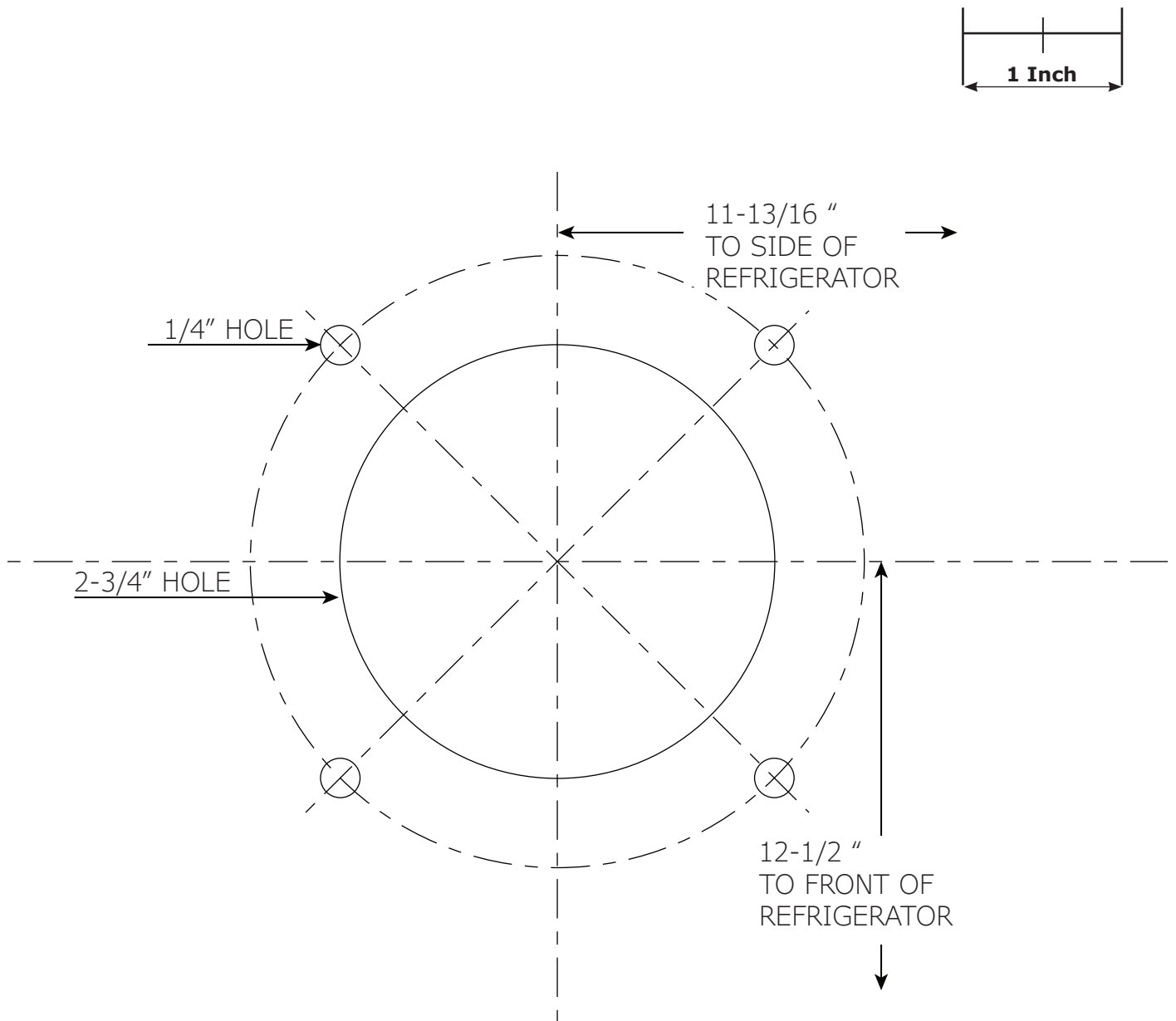

Diagram B



Template for Countertop Installation

Note: Verify template has printed true to scale - double check hole dimensions and placement.



Connecting Internal Nitrogen Source

Install Infuser Regulator

1. Align infuser regulator with pre-drilled holes in upper left/right of interior side wall. Use 2 screws to secure.

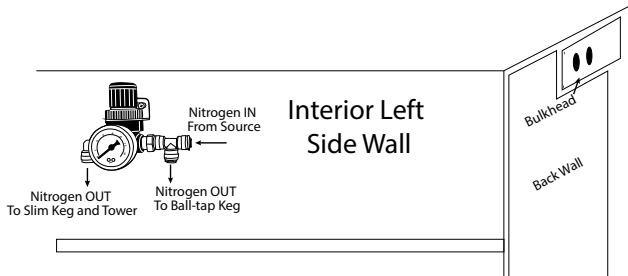

Nitrogen Connections

1. Attach ball valve (not included) to tank regulator (not included). Tighten with an adjustable wrench. Make sure valve is in the off position - turned clockwise as far as it can go.

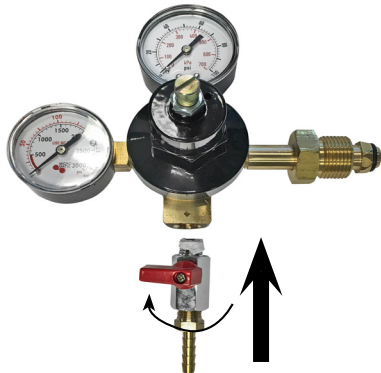

2. Attach regulator to nitrogen tank. Hand tighten the coupling nut and then use an adjustable wrench for an additional quarter turn. DO NOT OVER TIGHTEN.



NOTE: Make sure valve is in the off position - turned clockwise as far as it can go.

3. With a knife, cut off one end of the nitrogen braided line.

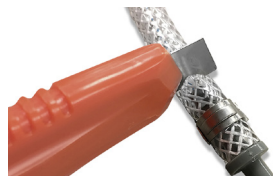

4. Attach braided line to ball valve on tank regulator using white snap ring.

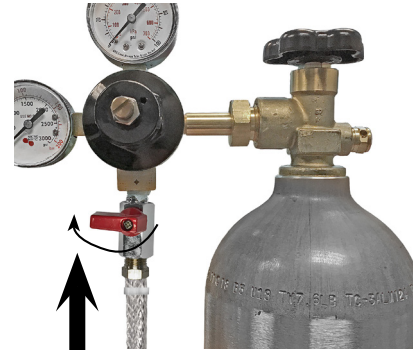

5. Attach other end of braided line to T-connector on infuser regulator.

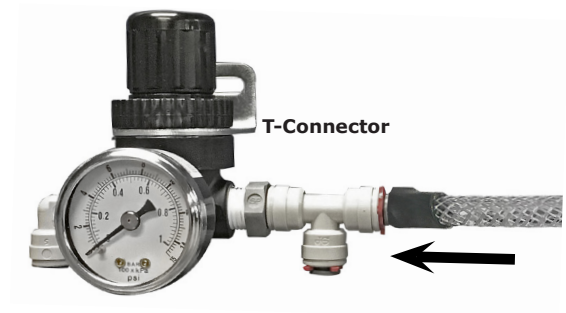

6. Attach gas jumper line to T-connector on infuser regulator - line up and press in firmly.

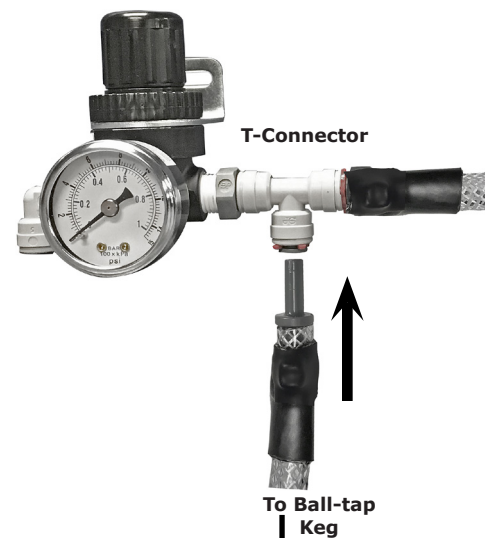

Connecting External Nitrogen Source

Note: Connection to an external Nitrogen source requires drilling one hole through the pre-installed bulkhead located near the top of the back wall. This will allow a grommet sized to .453" hose to fit.

Install Infuser Regulator

1. Align infuser regulator with pre-drilled holes in upper back corner of desired side wall. Use 2 screws to attach regulator.

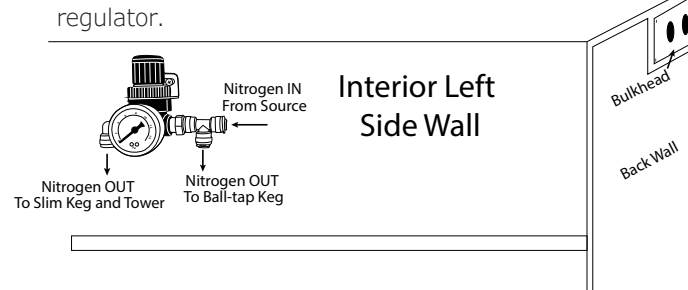

Prepare bulkhead and back panel

1. Inside the cabinet, drill out 1 of the 9/16" holes in the bulkhead.

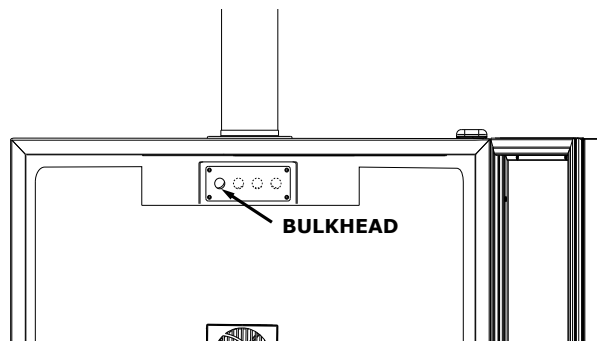

2. Insert grommet into drilled-out hole and apply food grade lubricant to the inside of grommet.

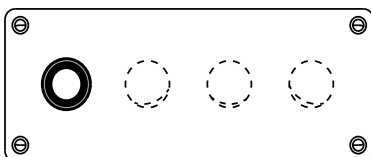

3. In the back of the unit, remove back panel.

4. Insert grommet into hole that corresponds to the drilled-out hole in bulkhead and apply food grade lubricant to inside of the grommet.

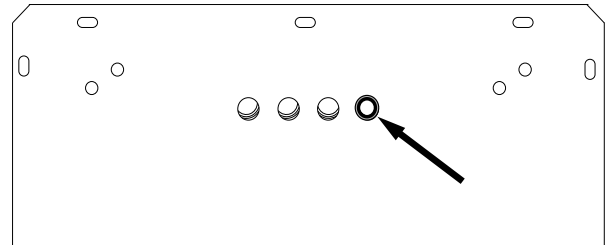

5. Inside cabinet push nitrogen hose through drilled-out hole.

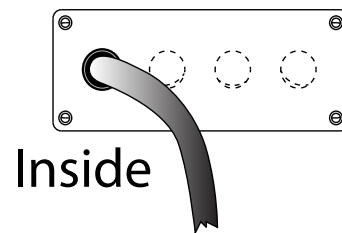

6. At the back of the unit, apply food grade lubricant to inside of the grommet and push nitrogen hose through.

7. Re-install back panel.

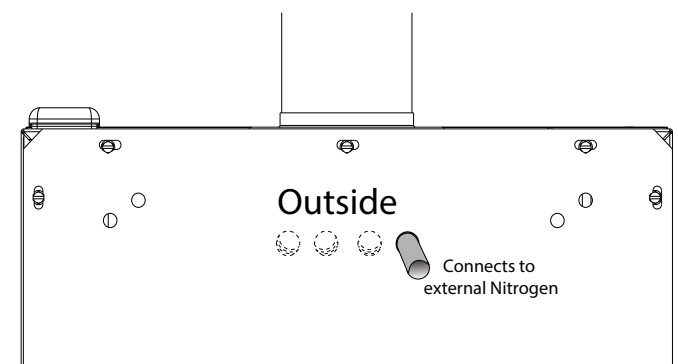

8. Connect nitrogen hose to external nitrogen source.

9. Continue with inside connections (see CONNECT NITROGEN TO KEGS in this manual)

Connect Nitrogen to Kegs

1. Cut 2" of hose from supplied 1/4" white nitrogen hose.
2. Insert one end of hose into elbow on infuser regulator.
3. Attach T-connector to other end of hose.
4. Connect gas line from the tower to end of T-connector.
5. Connect blue gas line to center of T-connector.

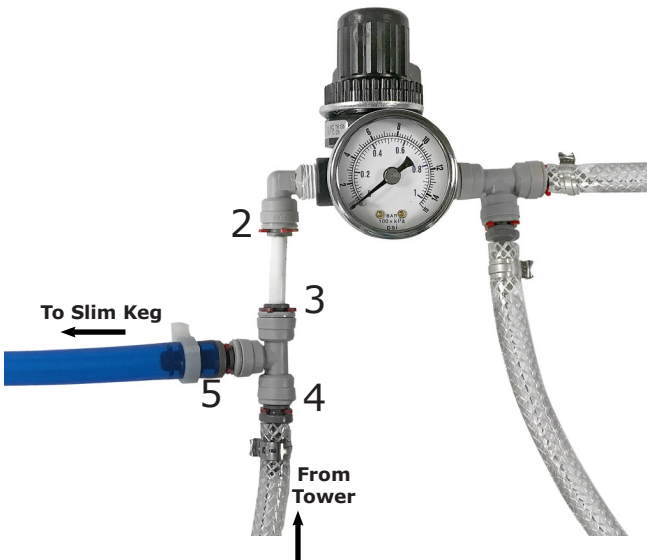

6. Attach gray coupler of the gas jumper line to keg. With your thumb press down on the top of the coupler while pulling up on collar. Press coupler down firmly onto "in" valve. Release collar - listen for a click. Pull up on the coupler to ensure it is locked down.



7. Attach and clamp blue hose to lo-boy coupling.



Connecting Internal CO₂ Source Install Regulator

NOTE: Make sure gas valve on tank and two gas valves on regulator are turned all the way clockwise to the off position.

1. Attach regulator to CO₂ tank. Hand tighten the coupling nut and then use an adjustable wrench for an additional quarter turn. DO NOT OVER TIGHTEN
2. Attach 3/16" CO₂ hose (blue) to each regulator nipple and clamp into place. If necessary, make the hose more pliable by heating the end in boiling water.



3. Attach and clamp CO₂ hose to lo-boy coupling.

Connecting External CO₂ Source

Note: Connection to an external CO₂ source requires drilling a hole through the pre-installed bulkhead located near the top of the back wall. It is crucial to proper operation of the refrigerator that air tight insulation is installed around the incoming CO₂ hose.

Prepare bulkhead and back panel

1. Inside the cabinet, drill out 1 of the holes in the bulkhead

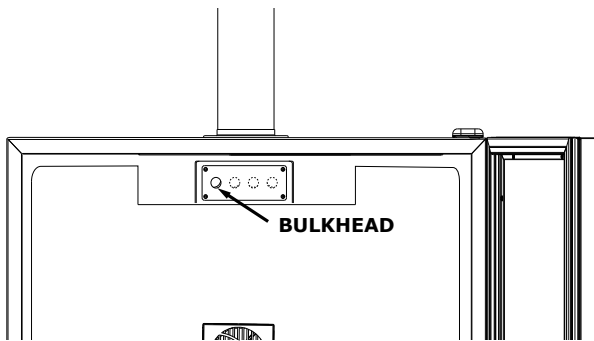

2. Insert insulation, such as a grommet, into drilled-out hole. It may be necessary to apply food grade lubricant to the inside of the grommet.

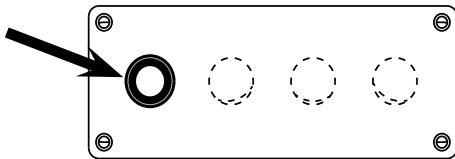

3. In the back of the unit, remove back panel.
4. Insert insulation, such as a grommet, into drilled-out hole. It may be necessary to apply food grade lubricant to the inside of the grommet.

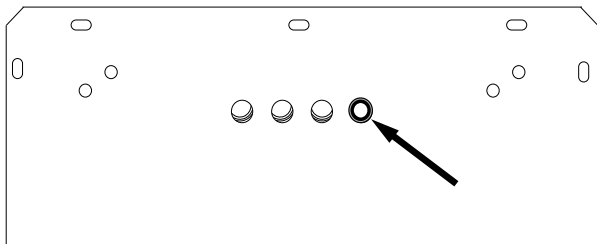

5. Inside cabinet push CO₂ hose through drilled-out hole.

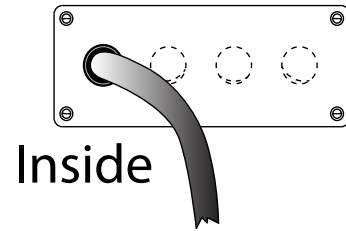

6. Re-install back panel.

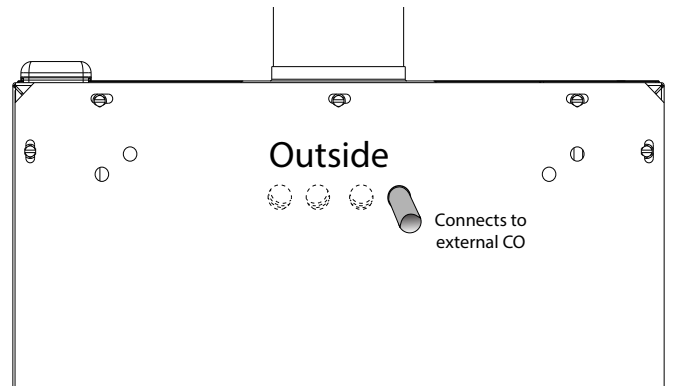

7. Continue with inside connections (see CONNECTING KEYS TO TOWER in this manual)

Connecting Kegs to Tower

1. Attach black coupler of the liquid jumper line to ball-tap keg. With your thumb press down on the top of the coupler while pulling up on the collar. Press coupler down firmly onto "out" valve. Release collar - listen for a click. Pull up on the coupler to ensure it is locked down.

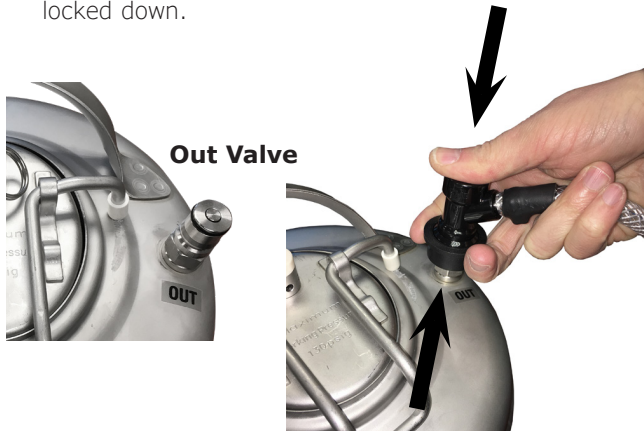

2. Connect and clamp clear beverage tubing from tower to lo-boy couplers.



3. Connect couplers to keg. Locate notch and rotate clockwise 1/4 turn.



4. Press down and rotate clockwise an additional 1/4 turn.



Connections

When complete, the connections should look like this:

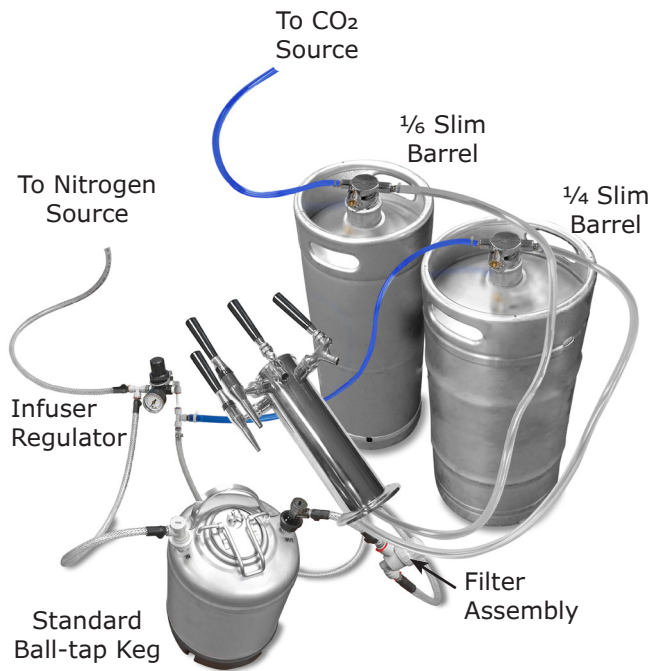

**Standard infuser regulator setup
One CO₂ line and Two Nitrogen lines**



**Alternate infuser regulator setup
Two CO₂ lines and One Nitrogen line**

LEVELING INFORMATION

1. Use a level to confirm the unit is level. Level should be placed along top edge and side edge as shown.
2. If the unit is not level, shim as needed.
3. Confirm the unit is level after each adjustment and repeat the previous steps until the unit is level.

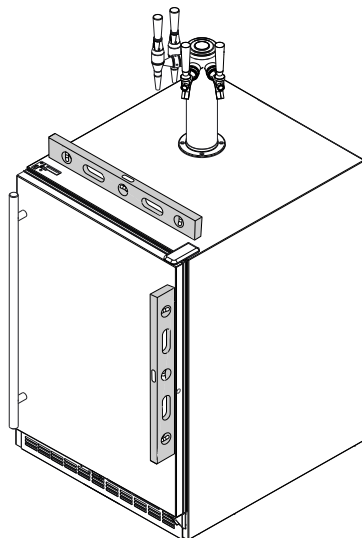

CAUTION

To comply with applicable federal, state, and local codes, it may be necessary to caulk the refrigerator to the floor.

CASTERS (optional)

1. Remove grille and back panel to access nuts.
2. Remove each nut and unscrew each leg.
3. Install each caster and secure with nut. Tighten with included wrench.
4. Replace grille and back panel.

When ready to use, see **FIRST USE** section in this manual.

Control Operation

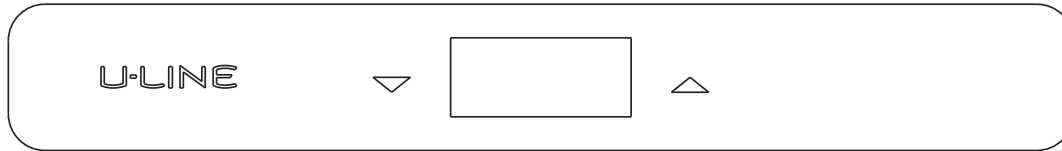

CONTROL FUNCTION GUIDE

FUNCTION	COMMAND	NOTES
ON/OFF	Press ▾ and hold for 5 seconds	Unit will turn On or OFF
Adjust Temperature	Press ▲ or ▾ and release	When the display is flashing, press ▲ or ▾ to adjust the set point temperature.
Toggle between °F / °C	Hold ▲ and ▾ for 5 seconds	The display will change units

Airflow and Product Loading

AIRFLOW

External

- Do not block the front grille - no additional clearance around sides, top or rear of unit is needed for ventilation
- Do not install behind a closed door

Internal

- When loading, leave space between internal fans, vents, and side walls to allow air to circulate freely

NOTICE

Restricting airflow may result in poor product performance, product failure, and uneven internal temperatures and may freeze contents.

First Use

Initial startup requires no adjustments. If the unit was turned off, press and hold ▾ for 5 seconds to turn unit on. See "Control Operation" section for more details.

NOTICE

Temperature displayed reflects actual temperature inside unit.

If the temperature displayed is different than selected, the unit is progressing towards the selected temperature. Time to reach set point varies based upon ambient temperature, temperature of product loaded, door openings, etc. U-Line recommends allowing the unit to reach set points before loading.

To dispense cold coffee, make sure the components are assembled according to the instructions in GENERAL INSTALLATION.

Setting CO₂ Pressure

To minimize foam for most beverages the pressure should be set between 8-12 PSI.

- Set the pressure by turning the handle on the front of the regulator counterclockwise until it is all the way out. This will turn the regulator off.
- Turn the valves on the bottom of the regulator to the side to ensure no CO₂ will pass through the regulator (Diagram A).
- Pull the pin on the sides of the couplers to release built up pressure from the kegs. Open the tap heads. Nothing should come out initially as there is no pressure to the keg.
- Place a container under the tap heads and open the valves on the bottom of the regulator (Diagram B).
- Turn the handle clockwise with the tap heads open and your beverage will start to pour. Stop turning when you get the best flow rate. This method should prevent your regulator from creeping.

If you are dispensing at altitude, you will need to increase your output pressure by one pound for every 2,000 feet of elevation above sea level.

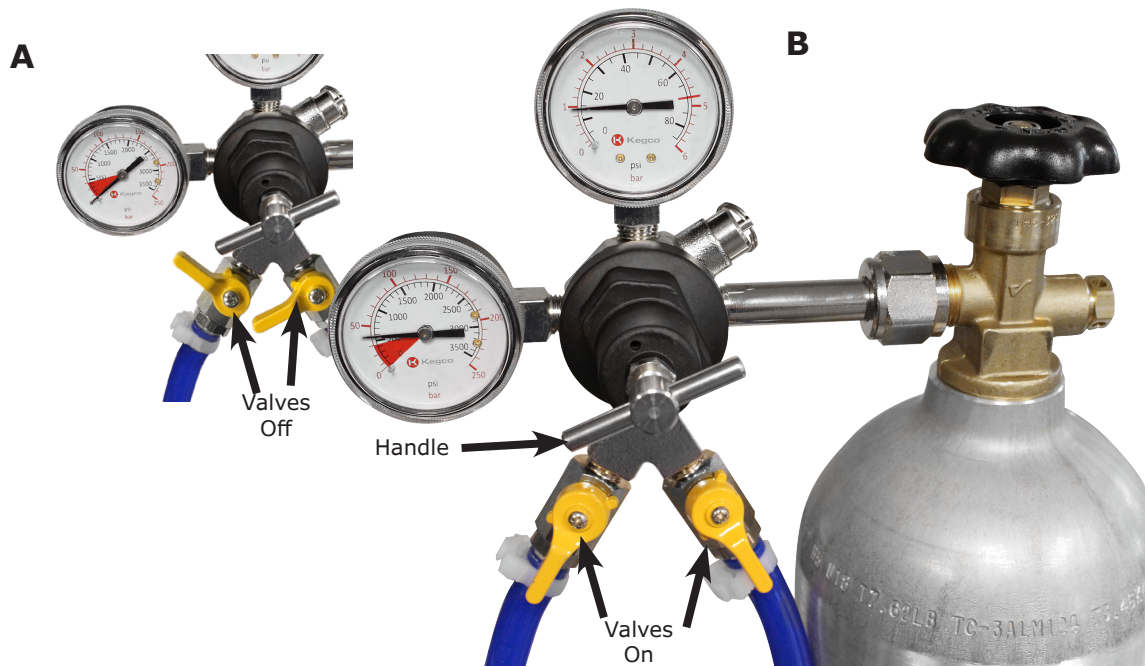

Cleaning

CLEANING VS. SANITIZING

This guide will address both the cleaning and the sanitizing of the unit.

Clean the unit to remove dried food and spills, to prevent build-up of grime, and to maintain the natural luster stainless steel surfaces.

Sanitize the unit when exposed to raw meat juice or human germs such as from a sneeze or being touched by someone who is ill. Sanitizing the unit can also be part of regular cleaning routine.

Stainless Surfaces

Stainless door panels, handles and frames can discolor when exposed to chlorine gas, pool chemicals, saltwater or cleaners with bleach.

Keep your stainless unit looking new by cleaning with a good quality all-in-one stainless steel cleaner and polish monthly. For best results use Claire® Stainless Steel Polish and Cleaner. Comparable products are acceptable. Frequent cleaning will remove surface contamination that could lead to rust. Some installations may require cleaning weekly.

Do not clean with steel wool pads.

Do not use stainless steel cleaners or polishes on any glass surfaces.

Clean any glass surfaces with a non-chlorine glass cleaner.

Do not use cleaners not specifically intended for stainless steel on stainless steel surfaces (this includes glass, tile, and counter cleaners).

If any surface discoloring or rusting appears, clean it quickly with Bon-Ami® or Barkeepers Friend Cleanser® and a nonabrasive cloth. Always clean with the grain. Always finish with Claire® Stainless Steel Polish and Cleaner or comparable product to prevent further problems.

Using abrasive pads such as ScotchBrite™ will cause the graining in the stainless steel to become blurred.

Rust not cleaned up promptly can penetrate the surface of the stainless steel and complete removal of the rust may not be possible.

CLEAN INTERIOR COMPONENTS

Use warm or hot water with dish soap to clean all removed components and interior surfaces. You may use a vinegar and water solution in place of soap. Proceed to sanitizing.

Note: Cleaning soaps and vinegar solutions are not sanitizers.

SANITIZE INTERIOR COMPONENTS AND SURFACES

Choose a Commercial Sanitizer Safe for Stainless Steel

- Read the directions for proper use to ensure that the surface will actually be sanitized
- Many products require rinsing with water after use, especially when food will be touching the surface
- Some products require a wait time before rinsing
- Verify the sanitizer you are using is safe for stainless steel.

Mix Your Own Sanitizer

Isopropyl Alcohol (rubbing alcohol)

1. Fill a clean, empty spray bottle with isopropyl alcohol
2. Spray surface
3. Wait 20 minutes
4. Dampen a non-abrasive cloth with isopropyl alcohol and wipe down surface
5. Dry surface with a clean dry non-abrasive cloth

Unscented Bleach and Water

1. Create a solution of 1 tablespoon of unscented bleach with one gallon of water.
2. Submerge small parts for no more than 3 minutes - rinse immediately and allow to air dry or dry with a disposable paper towel.
3. Fill a clean, empty spray bottle with bleach solution.
4. Spray surface.
5. After 2-3 minutes, use clean potable water to thoroughly rinse off surface. Allow to air dry or dry with a disposable paper towel.
6. Sanitize the door and all holes where the hinges attach to the unit and the brackets attach to the door as well as all the screws.

CLEAN EXTERIOR SURFACES

Use Bon-Ami® or Barkeepers Friend Cleanser® and a nonabrasive cloth. Always clean with the grain. Always finish with Claire® Stainless Steel Polish and Cleaner or comparable product to prevent further problems.

INTERIOR CLEANING & SANITIZING

NOTICE

Do not use any solvent-based or abrasive cleaners. These types of cleaners may transfer taste and/or odor to the interior products and damage or discolor the interior.

Cleaning the Coffee-Dispensing System

The system should be cleaned each time you change your coffee tank and before extended periods of non use using a solution of water and ULACOFFEECLEAN. One packet of ULACOFFEECLEAN (Stera-Sheen®) was included with your product and more can be purchased at u-line.com.

Notice

Confirm system is not pressurized by turning off nitrogen – turn handle clockwise. Release pressure in system by pulling up on the release valve.



Cleaning Solution Preparation

Follow safety instructions on packet. Mix ULACOFFEECLEAN with 2 gallons of warm (100°F/38°C) potable water.



Tap Heads

Clean the tap heads with warm soapy water. Remove nose cones and soak in the cleaning solution for at least five minutes. Rinse with clean potable water, dry and reattach.



Nose Cone

Infuser Filter

Disassemble by unscrewing the cap. Rinse cap and filter with warm potable water and reassemble.

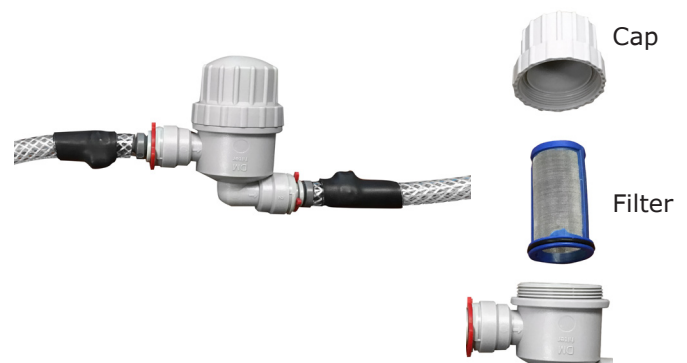

Cap

Filter

Line and System Cleaning

1. Remove the contents, clean the keg with water warm soapy water, and rinse.
2. Pour the cleaning solution into keg, attach hoses and open the nitrogen valve to pressurize the system.
3. Place a bucket under the taps. Pull and hold the left tap open until approximately ½ gallon of cleaning solution is dispensed. Close the left tap head. Pull and hold the right tap head handle until ½ gallon of solution is dispensed. Discard solution.
4. Allow the cleaning solution to remain in the system for a minimum of five minutes.
5. Dispense approximately ¼ gallon of the solution through the left tap. Dispense the remaining solution from the right tap. No rinsing is required.
6. Unless refilling, remove lid from keg to allow keg to air dry.

Cleaning the Beer-Dispensing System

Clean the system using a suitable solution designed for beer-dispensing systems. Beer cleaning kits are also available. Solution and/or kit not included.

1. Close CO₂ tank.
2. Pull pin on coupler to release pressure from keg.
3. Remove tap coupler from keg.
4. Remove CO₂ line from tap coupler.
5. Open tap coupler to allow cleaning solution to flow through it:
 - Push base of coupler inward and rotate clockwise.
6. Open cleaning pump.
7. Empty one packet of cleaner into plastic jar and fill with cool water.
8. Reassemble pump.

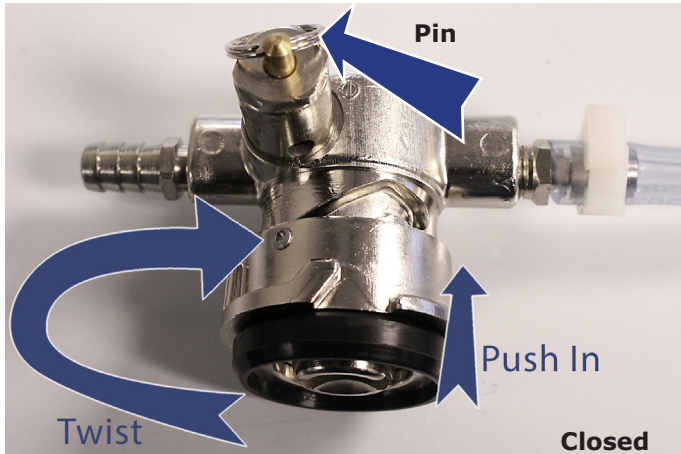

9. Remove tap head from tower with supplied tap head wrench. Disassemble, and place all the parts in drainage bucket.
10. Add washer and attach cleaning pump connector to tower. Tighten with tap head wrench.
11. Pump all the solution through the beverage line.
12. Allow tap coupler and tap head to soak in drainage bucket and then use tap head brush to clean tap head.
13. Rinse out and refill plastic jar with clean water. Pump all the water through the beverage line to rinse.
14. Rinse all disassembled parts with clean water.
15. Reassemble tap head and reconnect CO₂ and beverage lines.

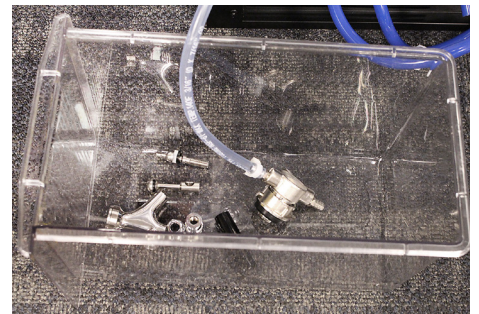

Disassembled Tap Head

DEFROSTING

Under normal conditions this unit does not require manual defrosting. Minor frost on the rear wall or visible through the evaporator plate vents is normal and will melt during each cycle.

If there is excessive build-up of 1/4" (6 mm) or more, manually defrost the unit.

Ensure the door is closing and sealing properly.

High ambient temperature and excessive humidity can also produce frost.



DO NOT use an ice pick or other sharp instrument to help speed up defrosting. These instruments can puncture the inner lining or damage the cooling unit. DO NOT use any type of heater to defrost. Using a heater to speed up defrosting can cause personal injury and damage to the inner lining.

NOTICE

The drain pan was not designed to capture the water created when manually defrosting. To prevent water from overflowing the drain pan and possibly damaging water sensitive flooring, the unit must be removed from cabinetry.

To defrost:

1. Disconnect power to the unit.
2. Remove all products from the interior
3. Prop the door in an open position (2 in. [50 mm] minimum).
4. Allow the frost to melt naturally.
5. After the frost melts completely, clean the interior and all removed components. (See INTERIOR CLEANING).
6. When the interior is dry, reconnect power and turn unit on.

U-Line Corporation (U-Line) Limited Warranty

One Year Limited Warranty

For one year from the date of original purchase, this warranty covers all parts and labor to repair or replace any part of the product that proves to be defective in materials or workmanship. For products installed and used for normal residential use, material cosmetic defects are included in this warranty, with coverage limited to 60 days from the date of original purchase. All service provided by U-Line under the above warranty must be performed by a U-Line factory authorized servicer, unless otherwise specified by U-Line. Service provided during normal business hours.

Two Year Limited Warranty (5 Class Product)

For two years from the date of original purchase, this warranty covers all parts and labor to repair or replace any part of the product that proves to be defective in materials or workmanship. For products installed and used for normal residential use, material cosmetic defects are included in this warranty, with coverage limited to 60 days from the date of original purchase. All service provided by U-Line under the above warranty must be performed by a U-Line factory authorized servicer, unless otherwise specified by U-Line. Service provided during normal business hours.

Available Second & Third Year Limited Warranty

In addition to the standard one and two year warranties outlined above, U-Line offers a one year extension of the warranties from the date of purchase, free of charge. To take advantage of this extension, you must register your product with U-Line within 60 days from the date of purchase at u-line.com and provide proof of purchase.

Five Year Sealed System Limited Warranty

For five years from the date of original purchase, U-Line will repair or replace the following parts, labor not included, that prove to be defective in materials or workmanship: compressor, condenser, evaporator, drier, and all connecting tubing. All service provided by U-Line under the above warranty must be performed by a U-Line factory authorized servicer, unless otherwise specified by U-Line. Service provided during normal business hours.

Terms

These warranties apply only to products installed in any one of the fifty states of the United States, the District of Columbia, or the ten provinces of Canada. The warranties do not cover any parts or labor to correct any defect caused by negligence, accident or improper use, maintenance, installation, service, repair, acts of God, fire, flood or other natural disasters. The product must be installed, operated, and maintained in accordance with your product's User Guide.

The remedies described above for each warranty are the only ones that U-Line will provide, either under these warranties or under any warranty arising by operation of law. U-Line will not be responsible for any consequential or incidental damages arising from the breach of these warranties or any other warranty, whether express, implied, or statutory. Some states do not allow the exclusion or limitation of incidental or consequential damages, so the above limitation or exclusion may not apply to you. These warranties give you specific legal rights, and you may also have other rights which vary from state to state.

Any warranty that may be implied in connection with your purchase or use of the product, including any warranty of *merchantability* or any warranty *fit for a particular purpose* is limited to the duration of these warranties, and only extends to five years in duration for the parts described in the section related to the five year limited warranty above. Some states do not allow limitations on how long an implied warranty lasts, so the above limitations may not apply to you.

- The warranties only apply to the original purchaser and are non-transferable.
- The second, third, and five year warranties cover products installed and used for normal residential or designated marine use only.
- The warranties apply to units operated outside only if designed for outdoor use by model and serial number.
- U-Line Commercial products are covered by the one year and 5 year limited warranties and are not eligible for the second and third year limited warranties.
- Replacement water filters, light bulbs, and other consumable parts are not covered by these warranties.
- The start of U-Line's obligation is limited to four years after the shipment date from U-Line.
- In-home instruction on how to use your product is not covered by these warranties.
- Food, beverage, and medicine loss are not covered by these warranties.
- If the product is located in an area where U-Line factory authorized service is not available, you may be responsible for a trip charge or you may be required to bring the product to a U-Line factory authorized service location at your own cost and expense.
- Units purchased after use as floor displays, and/or certified reconditioned units, are covered by the limited one year warranty only and no coverage is provided for cosmetic defects.
- Signal issues related to Wi-Fi connectivity are not covered by these warranties.

For parts and service assistance, or to find U-Line factory authorized service near you, contact U-Line:
8900 N. 55th Street, Milwaukee, WI 53223 • u-line.com • onlineservice@u-line.com • +1.414.354.0300