

USER GUIDE & SERVICE MANUAL



Model: UCDE224ESS03A

Tip: Click on any section below to jump directly there

Table of Contents

Intro

Safety

Safety and Warning

Disposal And Recycling

Installation

Environmental Requirements

Electrical

Cutout & Product Dimensions

Anti-Tip Bracket

General Installation

Grille Installation

Door Swing

Door Adjust

Maintenance

Cleaning

Cleaning Condenser

Extended Non-Use

Operating Instructions

First Use

Control Operation

Airflow and Product Loading

Service

Troubleshooting

Wire Diagram

Product Liability

Warranty Claims

Parts

Ordering Replacement Parts

R600a Specifications

System Diagnosis Guide

Compressor Specifications

Troubleshooting Extended

Control Operation - Service

Thermistor

Defrost

Remove Fan and Cover

Warranty

WELCOME TO U-LINE

Congratulations on your U-Line purchase! Your product comes from a company with decades of premium modular ice making, refrigeration, and wine preservation experience. U-Line creates products focused on functionality, style, and inspired innovations — paying close attention to even the smallest details. Applications include residential, outdoor, ADA height compliant, marine, and commercial. Product categories include Beverage Centers, Wine Refrigerators, Ice Machines, Refrigerators, Freezers, and Dispensers. Our advanced refrigeration systems, large and flexible capacities, and clean integrated look are what makes our products Built-In to Stand Out®. Since 2014, U-Line has been part of the Middleby family of brands. Products are designed, engineered, and assembled in Milwaukee, Wisconsin, USA, and select products are available worldwide.

U-Line — RIGHT PRODUCT. RIGHT PLACE. RIGHT TEMPERATURE.®

PRODUCT INFORMATION

Looking for additional information on your product? User Guides, Spec Sheets, CAD Drawings, and Product Warranty information are available digitally on u-line.com.

PROPERTY DAMAGE / INJURY CONCERNS

In the unlikely event property damage or personal injury is suspected related to a U-Line product, please take the following steps:

1. U-Line Customer Care must be contacted immediately at +1.414.354.0300.
2. Service or repairs performed on the unit without prior written approval from U-Line is not permitted. If the unit has been altered or repaired in the field without prior written approval from U-Line, claims will not be eligible.

GENERAL INQUIRIES

U-Line Corporation
8900 N. 55th Street
Milwaukee, Wisconsin 53223 USA
Monday - Friday 8:00 am to 4:30 pm CST
T: +1.414.354.0300
Email: sales@u-line.com
u-line.com

SERVICE & PARTS ASSISTANCE

Monday - Friday 8:00 am to 4:30 pm CST
T: +1.414.354.0300
Service Email: onlineservice@u-line.com
Parts Email: onlineparts@u-line.com

CONNECT WITH US



Designed, engineered and assembled in WI, USA

Safety and Warning

NOTICE

Please read all instructions before installing, operating, or servicing the appliance.

Use this appliance for its intended purpose only and follow these general precautions with those listed throughout this guide:

SAFETY ALERT DEFINITIONS

Throughout this guide are safety items labeled with a Danger, Warning, or Caution based on the risk type:



Danger means that failure to follow this safety statement will result in severe personal injury or death.



Warning means that failure to follow this safety statement could result in serious personal injury or death.



Caution means that failure to follow this safety statement may result in minor or moderate personal injury, property, or equipment damage.



This unit contains R600a (Isobutane) which is a flammable hydrocarbon. It is safe for regular use. Do not use sharp objects to expedite defrosting. Do not service without consulting the “R600a specifications” section included in the User Guide. Do not damage the refrigerant circuit.



Service must be done by factory authorized service personnel. Any parts shall be replaced with like components. Failure to comply could increase the risk of possible ignition due to incorrect parts or improper service.

CALIFORNIA PROPOSITION 65

This product contains chemicals known to the state of California to cause cancer and birth defects or other reproductive harm.

www.P65warnings.CA.gov



This equipment is to be installed with adequate backflow protection to comply with applicable federal, state and local codes.

Disposal and Recycling

 **DANGER**

RISK OF CHILD ENTRAPMENT. Before you throw away your old refrigerator or freezer, take off the doors and leave shelves in place so children may not easily climb inside.

If the unit is being removed from service for disposal, check and obey all federal, state, and local regulations regarding the disposal and recycling of refrigeration appliances, and follow these steps completely:

1. Remove all consumable contents from the unit.
2. Unplug the electrical cord from its socket.
3. Remove the door(s)/drawer(s).

Environmental Requirements

This unit is designed to operate between 50°F (10°C) and 100°F (38°C). Higher ambient temperatures may reduce the unit's ability to reach low temperatures and/or reduce ice production on applicable models.

For best performance, keep the unit out of direct sunlight and away from heat generating equipment.

In climates where high humidity and dew points are present, condensation may appear on outside surfaces. This is considered normal. The condensation will evaporate when the humidity drops.



Damages caused by ambient temperatures of 40°F (4°C) or below are not covered by the warranty.

Electrical



SHOCK HAZARD – Electrical Grounding Required. Never attempt to repair or perform maintenance on the unit until the electricity has been disconnected.

Never remove the round grounding prong from the plug and never use a two-prong grounding adapter.

Altering, cutting or removing power cord, removing power plug, or direct wiring can cause serious injury, fire, loss of property and/or life, and will void the warranty.

Never use an extension cord to connect power to the unit.

Always keep your working area dry.

NOTICE

Electrical installation must observe all state and local codes. This unit requires connection to a grounded (three-prong), polarized receptacle that has been placed by a qualified electrician.

The unit requires a grounded and polarized 115 VAC, 60 Hz, 15A power supply (normal household current). An individual, properly grounded branch circuit or circuit breaker is recommended. A GFCI (ground fault circuit interrupter) is usually not required for fixed location appliances and is not recommended for your unit because it could be prone to nuisance tripping. However, be sure to consult your local codes.

See CUTOUT & PRODUCT DIMENSIONS for recommended receptacle location.

Cutout & Product Dimensions

PREPARE SITE

Your U-Line product has been designed for either free-standing or built-in installation. When built-in, your unit does not require additional air space for top, sides, or rear. However, the front grille must NOT be obstructed, and clearance is required for an electrical connection in the rear.



Unit can NOT be installed behind a closed cabinet door.

CUTOUT DIMENSIONS

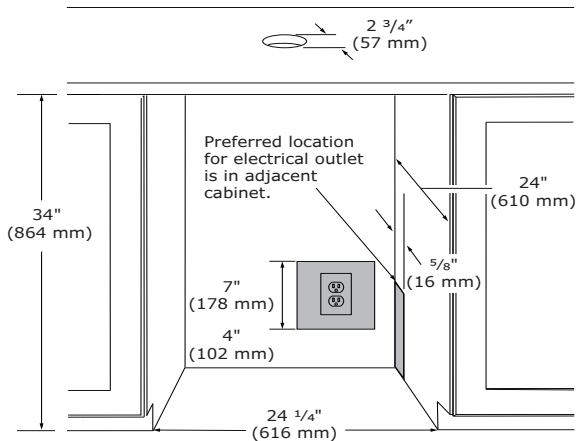

PRODUCT DIMENSIONS

REAR

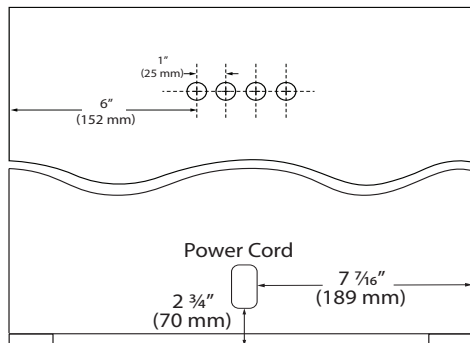

FRONT

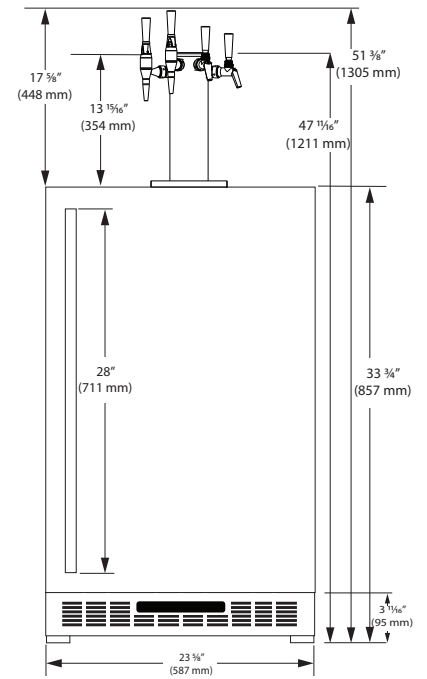

TOP

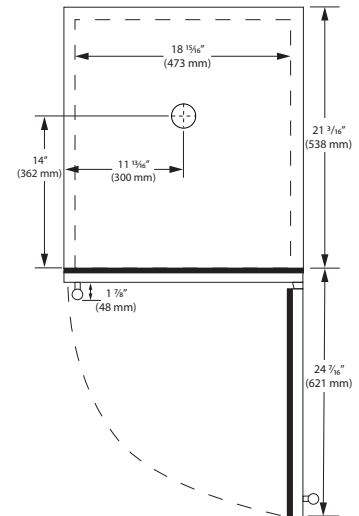

SIDE

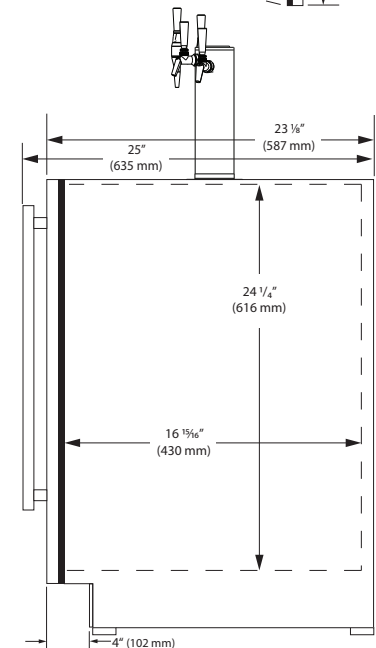

Anti-Tip Bracket

1. Slide unit out so screws on top of unit are easily accessible.
2. Remove the two screws from the opposite side of the hinge assembly using a T-25 Torx driver (see below).

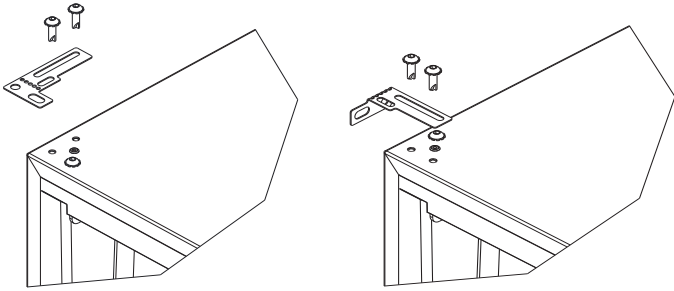

3. Place bracket over holes and attach to unit with two screws removed in step 2 using a T-25 Torx driver. Tighten screws fully.
4. Gently push unit into position. Be careful not to entangle the electrical cord or water line, if applicable.
5. Check to be sure the unit is level from front to back and side to side. Make any necessary adjustments. The unit's top surface should be approximately $\frac{1}{8}$ " (3 mm) below the countertop.
6. Secure bracket into adjoining surface.

General Installation

The following components are shipped inside the unit:

1. Tap tower (handles, & hardware)
2. Nitrogen hoses (connecting hardware)
3. Infuser regulator (mounting hardware)
4. Liquid jumper line (with in-line filters) and gas jumper line
5. Lo-boy keg couplers
6. CO₂ hoses (connecting hardware)
7. Cleaning solution (2-ounce packet)
(Additional cleaner, ULACOFFEECLEAN, is available at u-line.com)
8. Four casters (2 locking, 2 non-locking)
9. Drip tray
10. Adapter plate & Foam rubber gasket

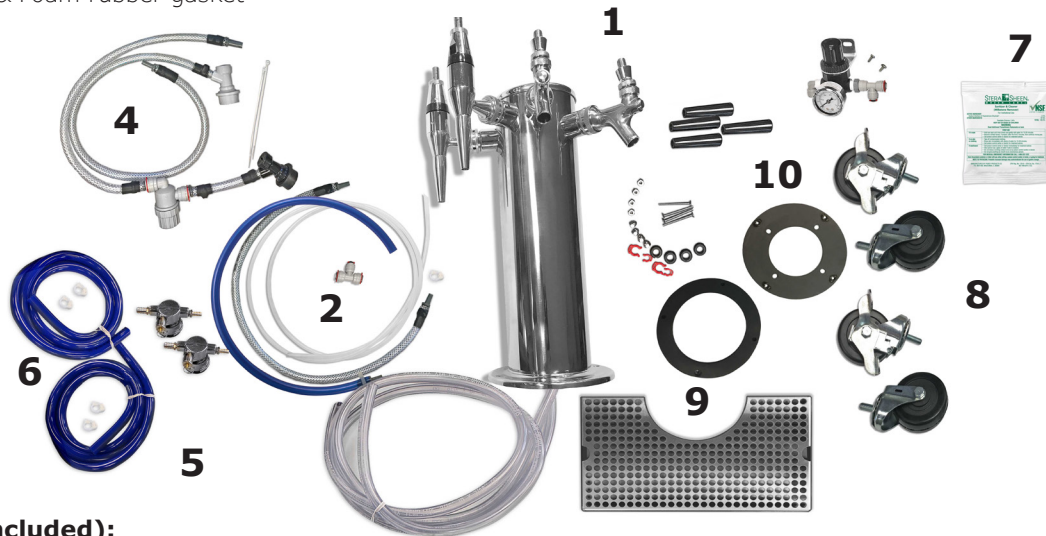

Required (not included):

1. Food grade 5 lb. nitrogen and 5 lb. CO₂ tank - available at your local gas supplier. 22 cubic feet aluminum empty tanks (ULANITROTANK) and nitrogen regulator (ULANITROREG) are available at u-line.com.



Note: If using an external nitrogen source, see CONNECTING EXTERNAL NITROGEN SOURCE section.

2. Food-grade lubricant if connecting to external nitrogen source.

3. 1 ball-tap keg - up to 5 gallons
4. 1 ¼ slim keg
5. 1 ⅙ slim keg
6. Your favorite cold coffee or tea and favorite beer, wine, or other beverage.

STANDARD BALL-TAP KEG



Safety and Warning



Keep nitrogen tank in an upright position and handle with care.

Never exceed 60 PSI.

Ventilate area after nitrogen leak.

Connect Hoses to Tower

Your tower comes with two hoses already attached.

1. Attach gas jumper hose - line up and press in firmly.

Note: The connector at the end of the gas jumper line is narrower to correspond with the connection in the tower.



2. Attach liquid jumper hose - line up and press in firmly.

Note: The connector at the end of the liquid jumper line is wider to correspond with the connection in the tower.



2. Install adapter plate to unit with 4 long screws and nuts (a) then place foam rubber gasket on top - open holes aligned (b).

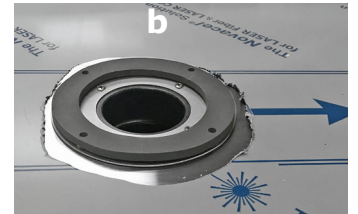
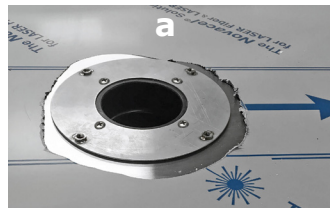

3. Insert all 4 hoses into the opening.



4. Install tower to unit with 4 short Philips screws.

NOTE: It will be necessary to press down firmly while tightening the screws. Compressing the foam rubber gasket ensures an airtight seal between the unit and the tower.

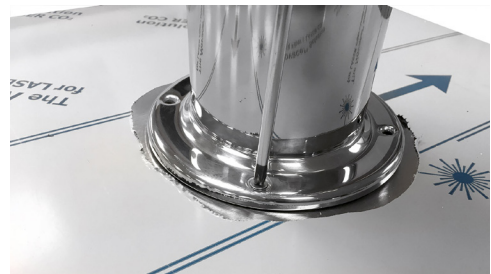

Install Tower on Refrigerator

Do not remove all the protective film on the stainless exterior until the tower is installed.

1. Remove four Phillips screws (secured with nuts on the inside of the refrigerator) and lift off cap to reveal tower mounting hole. Peel back enough film for tower to clear.

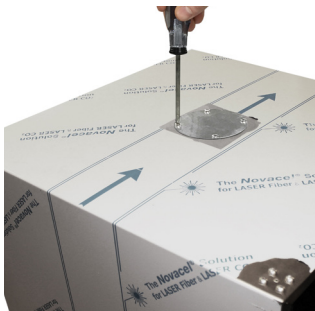

4 Short Screws

Foam Rubber Gasket

4 Long Screws
Adapter Plate

Rubber Gasket
Metal Ring

4 Nuts

4 Acorn Nuts

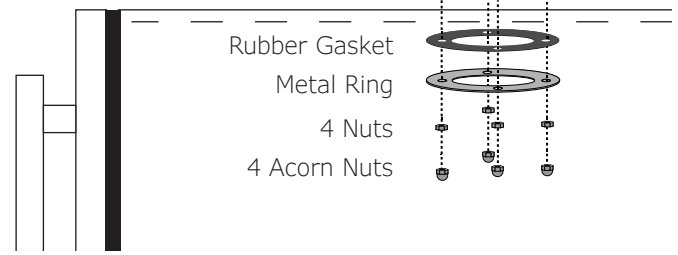
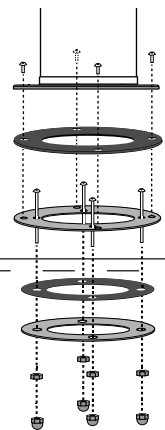

Install Tower on Countertop

(See template on next page)

Note: These instructions are designed for a standard 36" countertop application.

Note: For a customized fit, it may be necessary to acquire screws that are sized to the thickness of your countertop.

1. Position refrigerator under countertop to determine the desired depth.
2. Use the dimensions from Diagram A to determine the center point of the tower mounting hole.
3. Remove refrigerator from under countertop.
4. Use template to drill 4 mounting holes and drill 2-3/4" diameter hole through countertop.
5. If connecting to an external nitrogen and/or CO₂ source, prepare interior of refrigerator (see CONNECT EXTERNAL NITROGEN SOURCE & CONNECT EXTERNAL CO₂ SOURCE) and connect to main source.
6. Remove top cap from refrigerator and carefully slide refrigerator under countertop.
7. Connect nitrogen and liquid lines to tower and feed lines through hole all the way into refrigerator (see CONNECT HOSES TO TOWER).
8. Install adequate insulation between counter top and refrigerator - see Diagram B and note below.
9. Secure tower to countertop.
10. Continue with internal connections.

NOTE: For proper operation of your refrigerator, IT IS NECESSARY to install air-tight insulation between the refrigerator and the tower. The insulation will need to run from the interior of the refrigerator up into the interior of the tower.

Diagram A

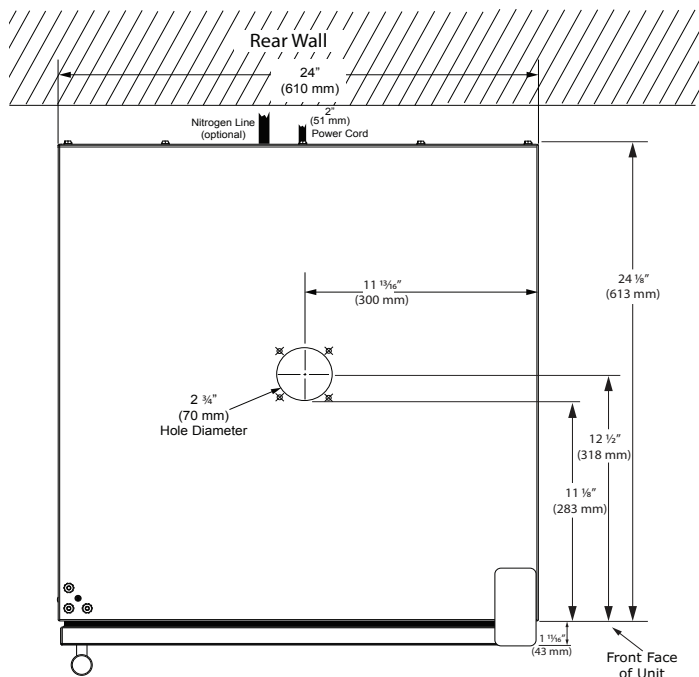
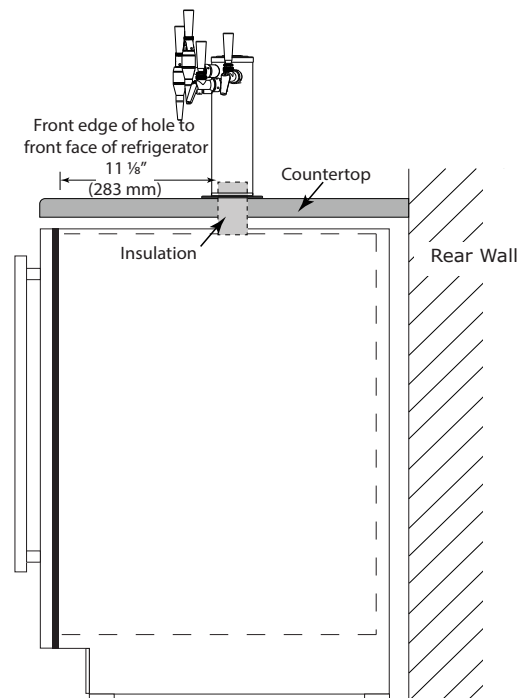
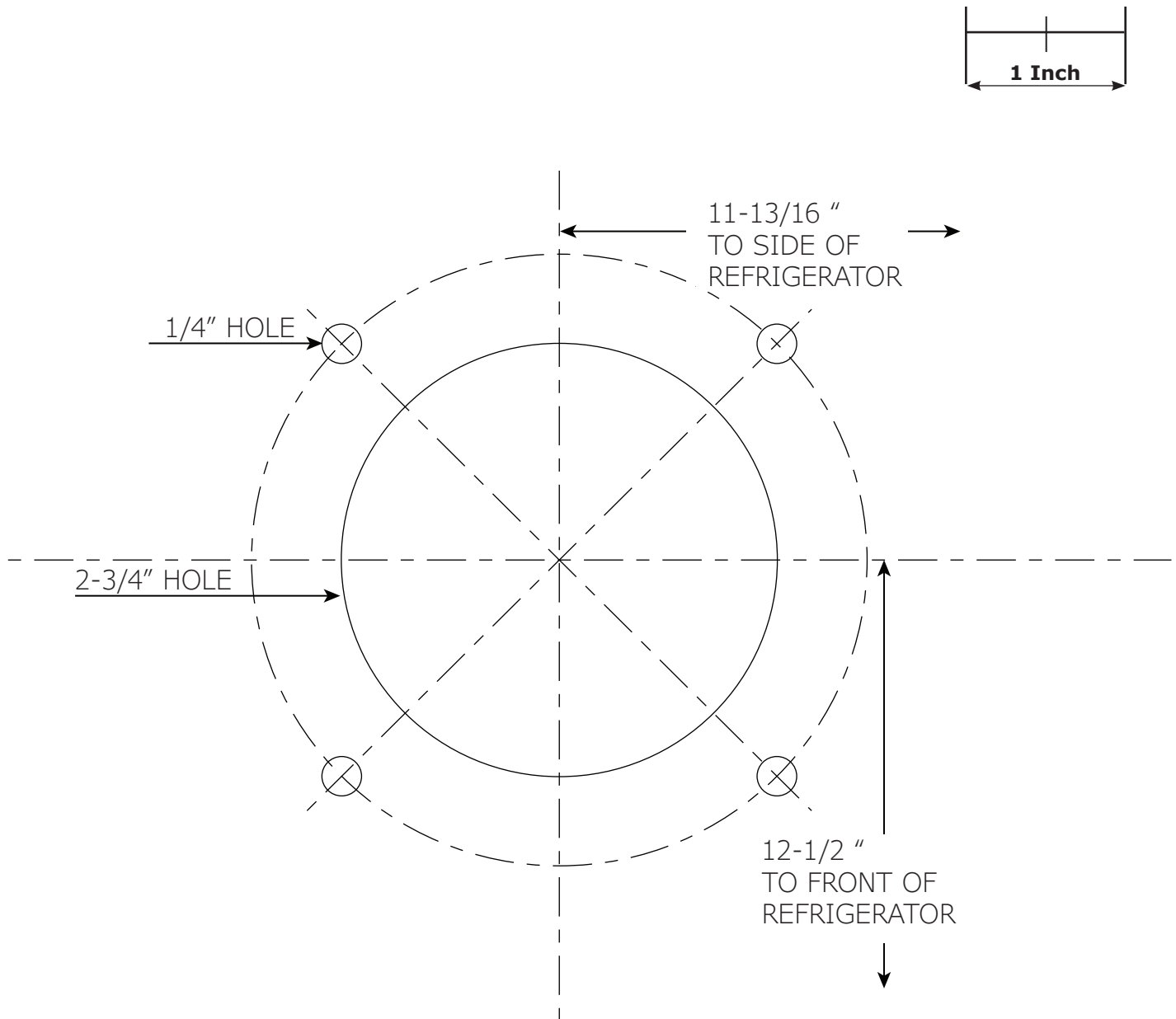

Diagram B



Template for Countertop Installation

Note: Verify template has printed true to scale - double check hole dimensions and placement.



Connecting Internal Nitrogen Source

Install Infuser Regulator

1. Align infuser regulator with pre-drilled holes in upper left/right of interior side wall. Use 2 screws to secure.

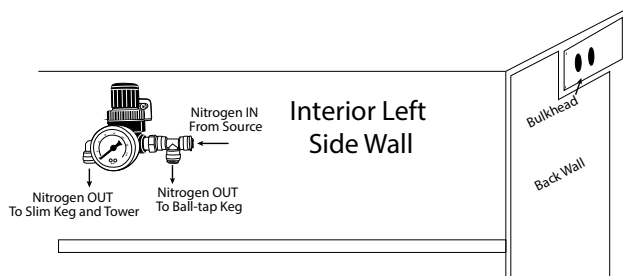

4. Attach braided line to ball valve on tank regulator using white snap ring.

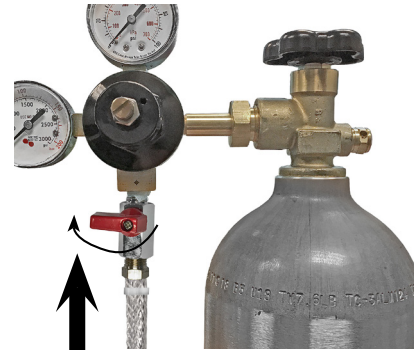

Nitrogen Connections

1. Attach ball valve (not included) to tank regulator (not included). Tighten with an adjustable wrench. Make sure valve is in the off position - turned clockwise as far as it can go.

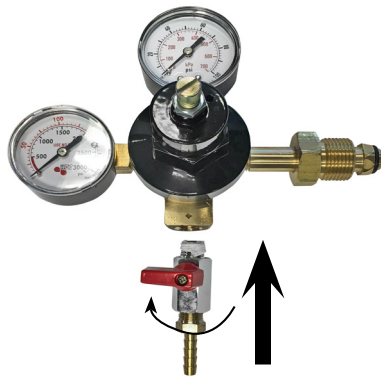

5. Attach other end of braided line to T-connector on infuser regulator.

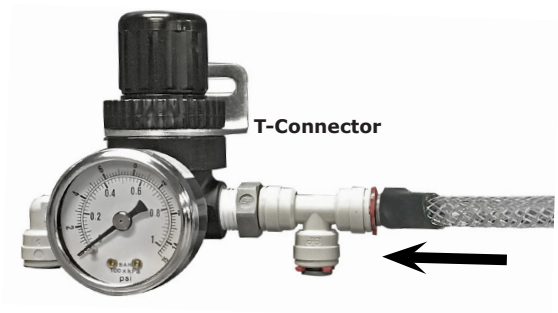

2. Attach regulator to nitrogen tank. Hand tighten the coupling nut and then use an adjustable wrench for an additional quarter turn. DO NOT OVER TIGHTEN.



6. Attach gas jumper line to T-connector on infuser regulator - line up and press in firmly.

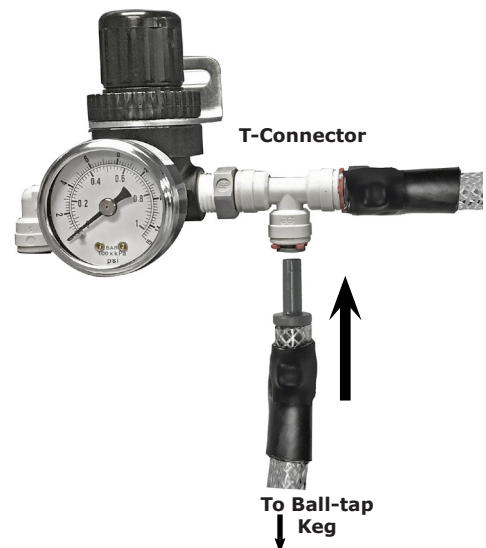

NOTE: Make sure valve is in the off position - turned clockwise as far as it can go.

3. With a knife, cut off one end of the nitrogen braided line.



Connecting External Nitrogen Source

Note: Connection to an external Nitrogen source requires drilling one hole through the pre-installed bulkhead located near the top of the back wall. This will allow a grommet sized to .453" hose to fit.

Install Infuser Regulator

1. Align infuser regulator with pre-drilled holes in upper back corner of desired side wall. Use 2 screws to attach regulator.

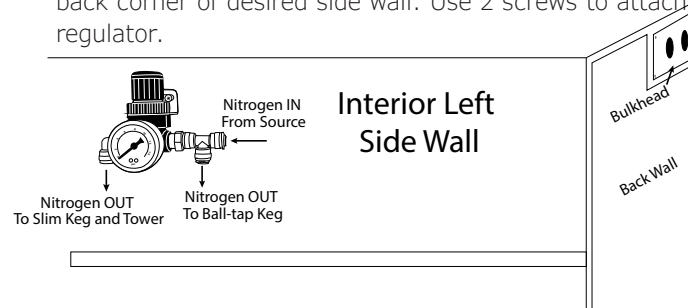

Prepare bulkhead and back panel

1. Inside the cabinet, drill out 1 of the 9/16" holes in the bulkhead.

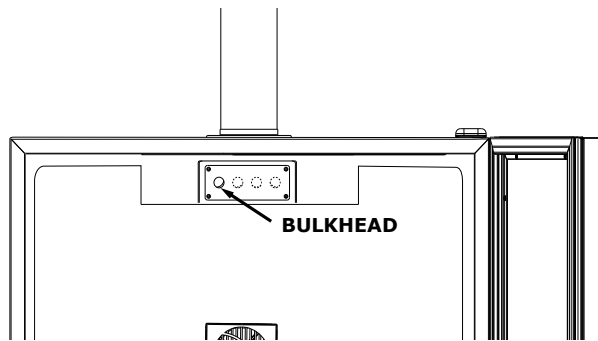

2. Insert grommet into drilled-out hole and apply food grade lubricant to the inside of grommet.

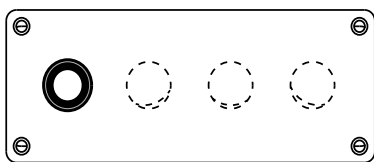

3. In the back of the unit, remove back panel.

4. Insert grommet into hole that corresponds to the drilled-out hole in bulkhead and apply food grade lubricant to inside of the grommet.

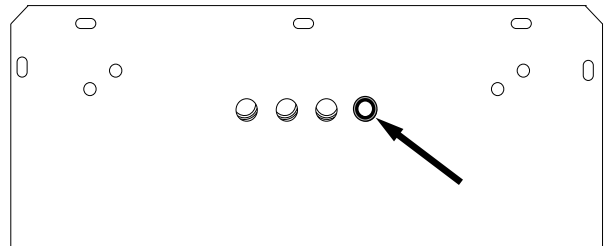

5. Inside cabinet push nitrogen hose through drilled-out hole.

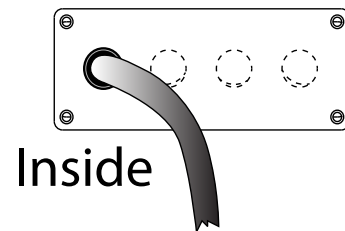

6. At the back of the unit, apply food grade lubricant to inside of the grommet and push nitrogen hose through.
7. Re-install back panel.

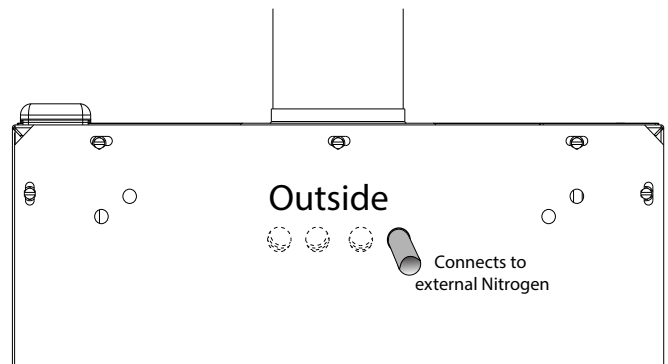

8. Connect nitrogen hose to external nitrogen source.
9. Continue with inside connections (see CONNECT NITROGEN TO KEGS in this manual)

Connect Nitrogen to Kegs

1. Cut 2" of hose from supplied 1/4" white nitrogen hose.
2. Insert one end of hose into elbow on infuser regulator.
3. Attach T-connector to other end of hose.
4. Connect gas line from the tower to end of T-connector.
5. Connect blue gas line to center of T-connector.

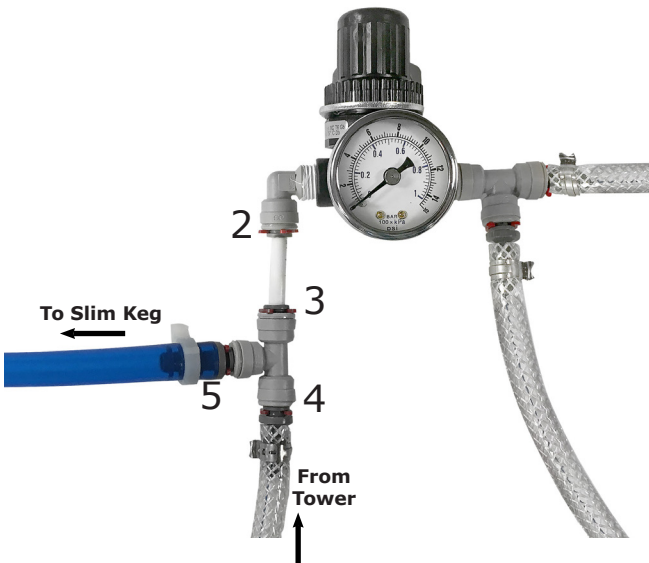

6. Attach gray coupler of the gas jumper line to keg. With your thumb press down on the top of the coupler while pulling up on collar. Press coupler down firmly onto "in" valve. Release collar - listen for a click. Pull up on the coupler to ensure it is locked down.



7. Attach and clamp blue hose to lo-boy coupling.



Connecting Internal CO₂ Source Install Regulator

NOTE: Make sure gas valve on tank and two gas valves on regulator are turned all the way clockwise to the off position.

1. Attach regulator to CO₂ tank. Hand tighten the coupling nut and then use an adjustable wrench for an additional quarter turn. **DO NOT OVER TIGHTEN**
2. Attach 1/16" CO₂ hose (blue) to each regulator nipple and clamp into place. If necessary, make the hose more pliable by heating the end in boiling water.



3. Attach and clamp CO₂ hose to lo-boy coupling.

Connecting External CO₂ Source

Note: Connection to an external CO₂ source requires drilling a hole through the pre-installed bulkhead located near the top of the back wall. It is crucial to proper operation of the refrigerator that air tight insulation is installed around the incoming CO₂ hose.

Prepare bulkhead and back panel

1. Inside the cabinet, drill out 1 of the holes in the bulkhead

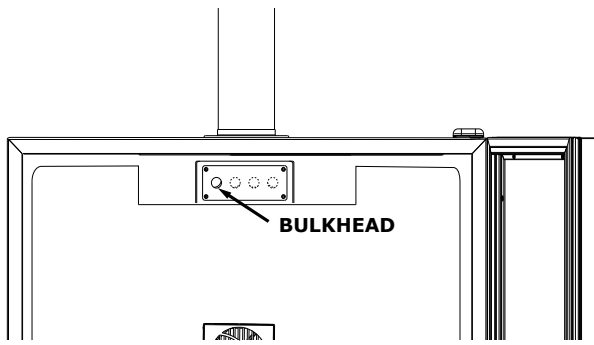

2. Insert insulation, such as a grommet, into drilled-out hole. It may be necessary to apply food grade lubricant to the inside of the grommet.

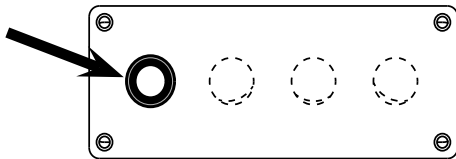

3. In the back of the unit, remove back panel.
4. Insert insulation, such as a grommet, into drilled-out hole. It may be necessary to apply food grade lubricant to the inside of the grommet.

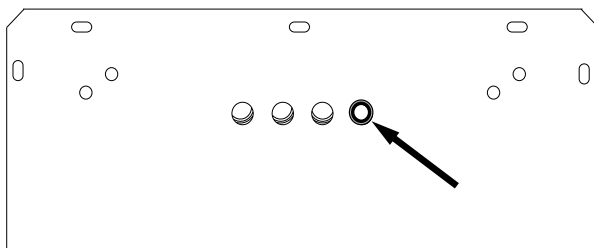

5. Inside cabinet push CO₂ hose through drilled-out hole.

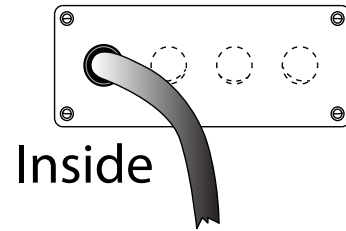

6. Re-install back panel.

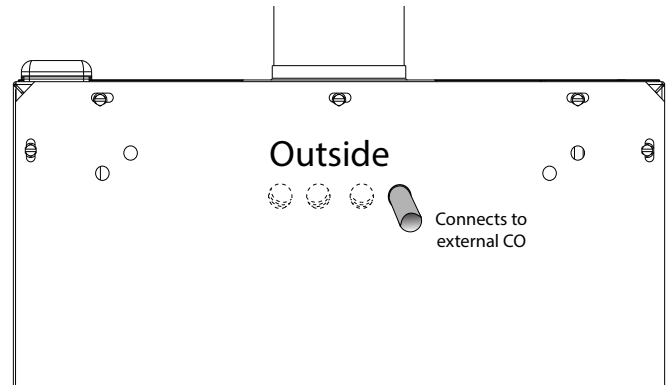

7. Continue with inside connections (see CONNECTING KEGS TO TOWER in this manual)

Connecting Kegs to Tower

1. Attach black coupler of the liquid jumper line to ball-tap keg. With your thumb press down on the top of the coupler while pulling up on the collar. Press coupler down firmly onto "out" valve. Release collar - listen for a click. Pull up on the coupler to ensure it is locked down.

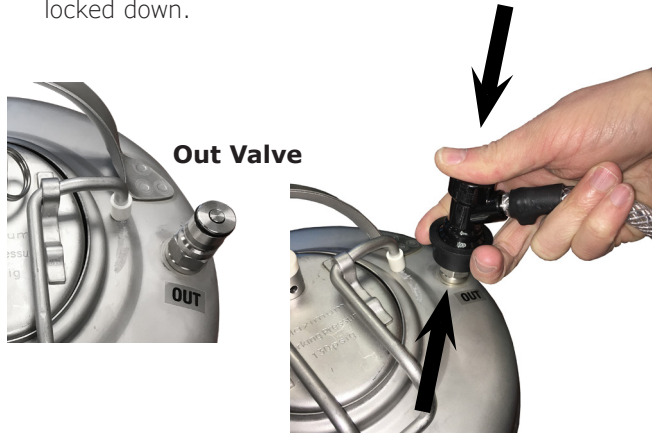

2. Connect and clamp clear beverage tubing from tower to lo-boy couplers.



3. Connect couplers to keg. Locate notch and rotate clockwise 1/4 turn.



4. Press down and rotate clockwise an additional 1/4 turn.



Connections

When complete, the connections should look like this:

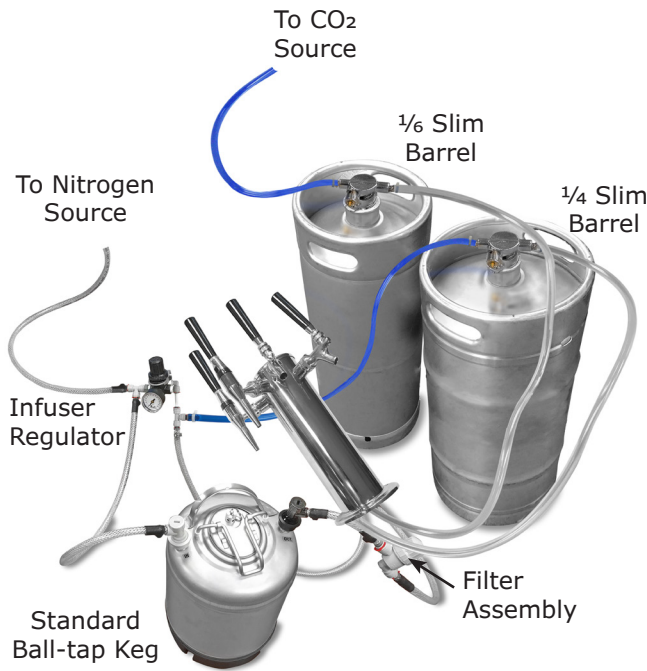

**Standard infuser regulator setup
One CO₂ line and Two Nitrogen lines**

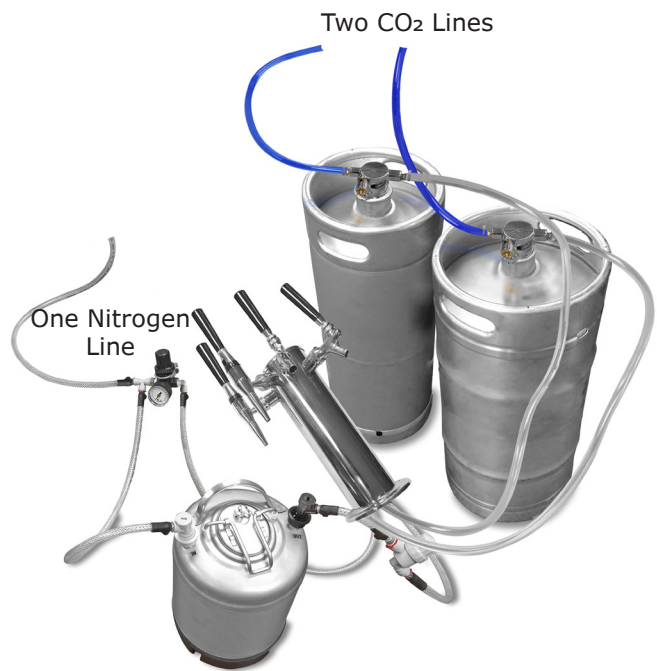

**Alternate infuser regulator setup
Two CO₂ lines and One Nitrogen line**

LEVELING INFORMATION

1. Use a level to confirm the unit is level. Level should be placed along top edge and side edge as shown.
2. If the unit is not level, shim as needed.
3. Confirm the unit is level after each adjustment and repeat the previous steps until the unit is level.

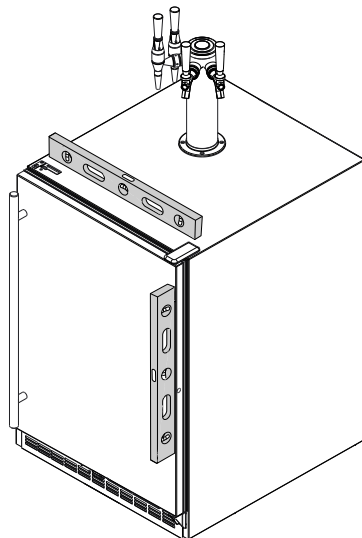

CAUTION

To comply with applicable federal, state, and local codes, it may be necessary to caulk the refrigerator to the floor.

CASTERS (optional)

1. Remove grille and back panel to access nuts.
2. Remove each nut and unscrew each leg.
3. Install each caster and secure with nut. Tighten with included wrench.
4. Replace grille and back panel.

When ready to use, see **FIRST USE** section in this manual.

Grille Installation

REMOVING AND INSTALLING GRILLE



Disconnect electric power to the unit before removing the grille.

When using the unit, the grille must be installed.

Removing the grille

Note: Grille and display are attached. The length of the display wire is sufficient to allow access to the front base components.

1. Disconnect power to the unit.
2. Loosen the two screws (1).
3. Remove grille (2) from unit.

Installing the grille

1. Align cabinet and grille holes and secure, but do not over tighten grille screws (1).
2. Reconnect power to the unit.

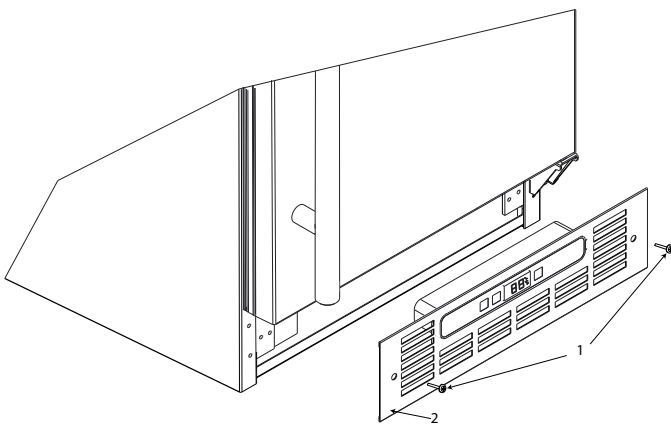

Door Swing

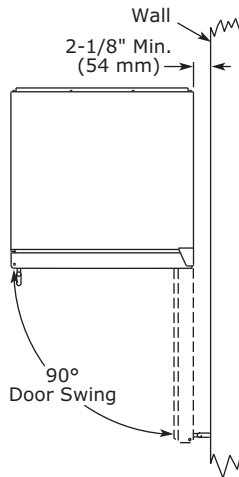

Units have a zero clearance for the door to open 90°, when installed adjacent to cabinets.

Stainless Steel models require 2-1/8" (54 mm) door clearance to accommodate the handle if installed next to a wall.

Door Adjustments

HINGE COVER

Hinge cover included with the literature bag is optional.

To install hinge cover:

1. Press hinge cover squarely over hinge.

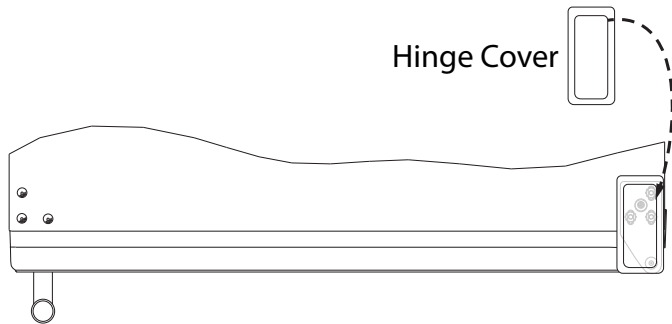

DOOR ALIGNMENT AND ADJUSTMENT

Align and adjust the door if it is not level or is not sealing properly. If the door is not sealed, the unit may not cool properly, or excessive frost may form in the interior.

NOTICE

Properly aligned, the door's gasket should be firmly in contact with the cabinet all the way around the door (no gaps). Carefully examine the door's gasket to ensure that it is firmly in contact with the cabinet. Also make sure the door gasket is not pinched on the hinge side of the door.

To align and adjust the door:

1. Gently pry off hinge cover from top of unit.
2. Loosen (do not remove) top and bottom hinge screws using a Philips screwdriver on the top and a 1/4" socket on the bottom.
3. Align door squarely with cabinet.
4. Make sure gasket is firmly in contact with cabinet all the way around the door (no gaps).
5. Tighten bottom hinge screws.
6. Tighten top hinge screws and replace hinge cover.

REVERSING THE DOOR

Location of the unit may make it desirable to mount the door on the opposite side of the cabinet.

The hinge hardware will be removed and reinstalled on the opposite side of the cabinet.

TO REVERSE THE DOOR

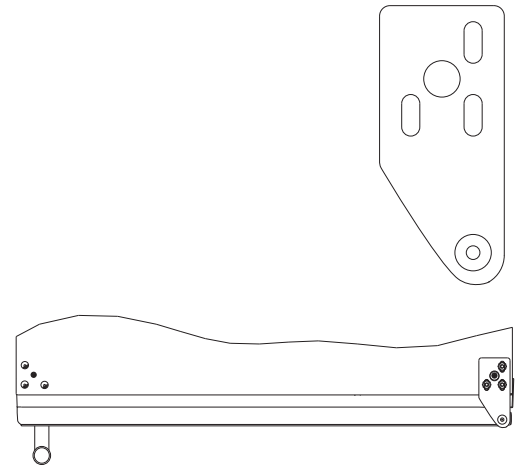

Remove grille:

Remove the grille (see GRILLE INSTALLATION section of this guide).

Remove arrow clips:

1. With a putty knife or other flat tool, gently pry each arrow clip from hinge mounting holes.
2. Set aside arrow clips to be reused on the opposite side.

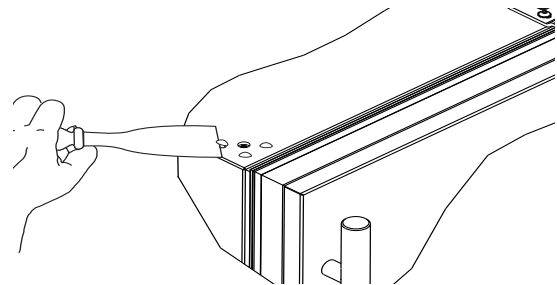

Remove top hinge and door:

1. Remove hinge cover from top of unit
2. Hold door to keep it from falling.
3. Remove top hinge from cabinet using a Philips screwdriver to remove three screws.

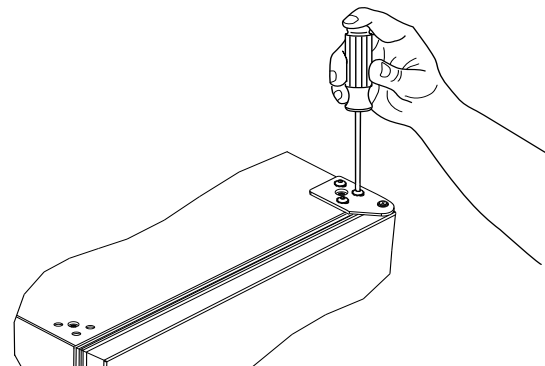

4. Remove door by tilting forward and lifting door off bottom hinge. Retain shoulder washers; they will be reused.
5. Use a Philips screwdriver to remove hinge pin and reinstall on the opposite surface of the hinge.
6. Install arrow clips in holes.

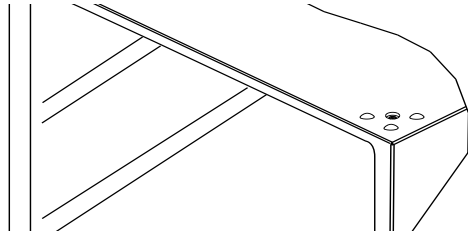

Remove bottom hinge:

1. Remove bottom hinge from cabinet using a 1/4" socket.

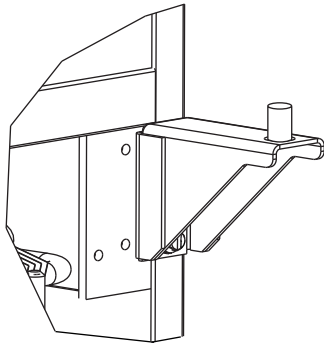

2. Remove corresponding screws on opposite side of cabinet. On some models there may be a nut behind one or both screws on either side.

Install bottom hinge:

Install two or three screws, depending on model. Replace nuts if used.

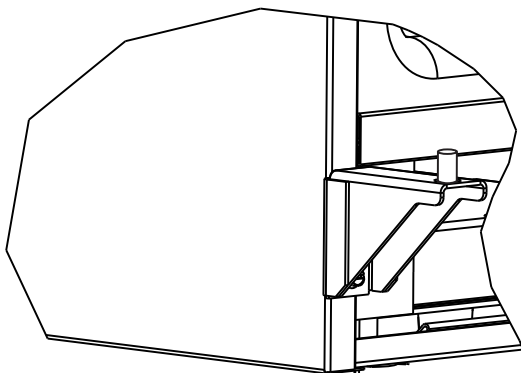

Install top hinge and door:

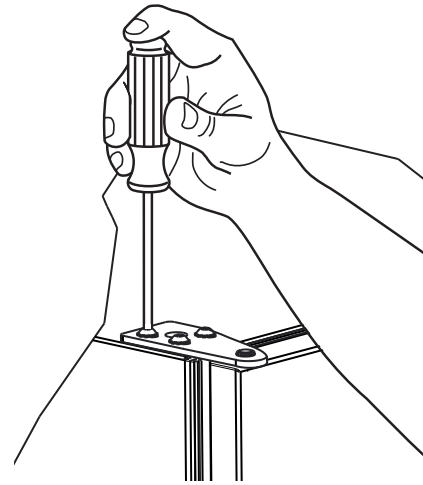

1. Rotate door 180° and lift the door on to the bottom hinge.
2. Install hinge that was used on the opposite side of the unit.
3. Align edge of the hinge with the outer edge of the unit while inserting hinge pin into top of door.
4. Tighten three screws and replace hinge cover.

Align and adjust the door:

Align and adjust the door (see DOOR ALIGNMENT AND ADJUSTMENT)

Install grille

First Use

Initial startup requires no adjustments. If the unit was turned off, press and hold  for 5 seconds to turn unit on. See "Control Operation" section for more details.

NOTICE

Temperature displayed reflects actual temperature inside unit.

If the temperature displayed is different than selected, the unit is progressing towards the selected temperature. Time to reach set point varies based upon ambient temperature, temperature of product loaded, door openings, etc. U-Line recommends allowing the unit to reach set points before loading.

To dispense cold coffee, make sure the components are assembled according to the instructions in GENERAL INSTALLATION.

4. Remove keg from refrigerator.
5. Lift handle and remove lid.



6. Fill keg with cold brew.
7. Replace and lock down lid.
8. Reattach hoses.

Fill the Keg

DE-PRESSURIZE SYSTEM

NOTICE

Before attempting to fill the keg it is necessary to confirm system is not pressurized.

1. Shut off nitrogen tank by turning handle clockwise until it stops.



2. Lift up on pressure release valve ring. Allow pressure to release.



3. Detach hoses from keg. (See General Installation section of this guide.)

Set Nitrogen Pressure

The pressure should be set around 20 - 30 PSI. Start at 25 PSI on regulated gauge; 7 PSI at infuser regulator.

1. Make sure red regulator valve is in the OFF position.

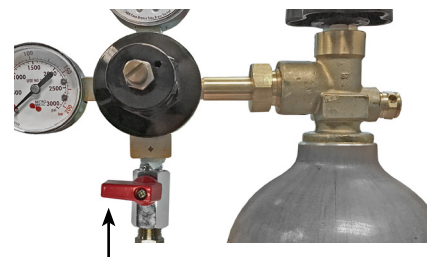

2. On top of Nitrogen tank, turn black handle counterclockwise until it stops.
3. Rotate the red regulator valve to ON Position; turn counterclockwise 1/4 turn until it stops

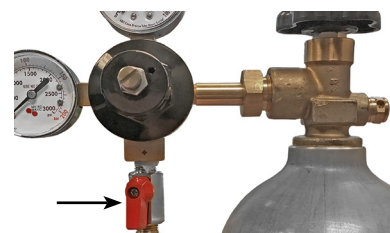

4. To adjust pressure, loosen locking nut, turn adjusting screw until desired pressure is reached, and retighten locking nut.

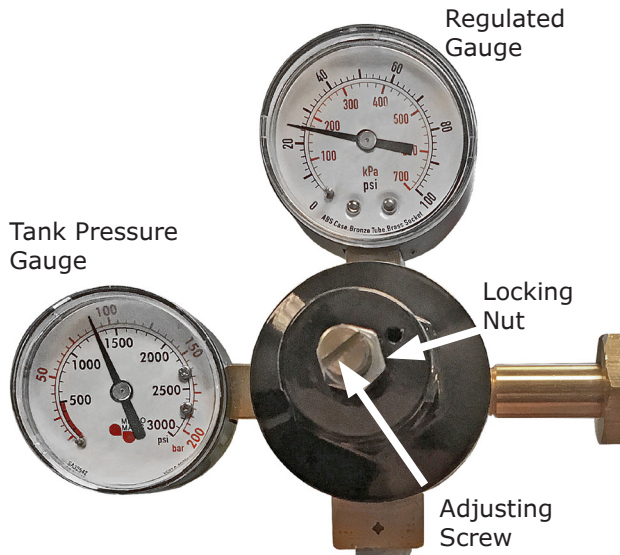

5. On infuser regulator, pull out middle knob to unlock then turn knob until needle points at 7 - turn right to increase; left to decrease.



6. Once set, lock in place by pressing middle knob in until it clicks.

Dispensing Coffee

The left tap delivers still cold brew which is refreshing and less acidic than hot coffee. The right tap delivers nitrogen-infused coffee which is the ultimate cold brew experience. Thousands of micro-nitrogen bubbles are infused as the coffee is dispensed. This creates a naturally slightly sweet taste and thicker and smoother texture.

Troubleshooting

ISSUE	CAUSE	SOLUTION
No/reduced liquid flow through faucet(s).	The strainer inside of the filter bowl assembly is clogged or beginning to clog.	See cleaning section
	Nitrogen source is empty or turned off.	If applicable, assure that the nitrogen tank is not empty and that the nitrogen shutoff switch is in the on position (in-line with the tube). Also assure that the knob on top of the tank is turned all the way counterclockwise. If the tank is empty, replace it with a full one.
	Liquid and/or nitrogen ball lock disconnects are not fully connected to product tank.	Attach the liquid/nitrogen ball lock disconnects to the product tank. If they already appear to be connected, disconnect/reconnect them.
	The nose cone of the faucet is clogged.	Detach the nose cone assembly from the stout faucet by turning it counterclockwise. Remove the stainless steel restrictor disc and inspect the small holes to assure that none of them are clogged.
	The system is dirty and requires a thorough line cleaning/sanitizing procedure.	Follow the line cleaning procedure above to remove buildup and restore full flow.
Too much or not enough nitrogen being infused into the product (head is too big or too small).	The secondary regulator is set to a pressure that is either too high or low.	If there is less/more nitro effect than desired, use the black knob on the secondary regulator assembly to make a change. To adjust the secondary regulator, pull the black knob out until you feel a slight click. This is the adjustment mode. To increase the level of nitro, turn this knob clockwise. To decrease the level of nitro, turn the knob counterclockwise. Continue adjusting and pouring until the level of nitro meets your requirements. Once you have found your desired level of nitrogenation, push the black knob back in to lock it in place.
	The strainer inside of the filter bowl assembly is beginning to clog.	See cleaning section
	The system is dirty and needs cleaned.	See cleaning section
Liquid leak.	Loose connection, broken fitting/tube, or loose faucet, nose cone or filter bowl assembly.	Immediately turn the nitrogen off to the system, disconnect the quick disconnects from the product tank and call customer support for consultation to assess the system.
Nitrogen leak (system is using nitrogen even when faucets are closed).	Product tank lid is not sealed completely.	Remove the lid and reattach making sure that the lid is centered and sealed.
	Fitting is loose, disconnected, or broken.	Immediately turn the nitrogen off to the system, disconnect the quick disconnects from the product tank and call customer support for consultation to assess the system.
The product is pouring too warm/cold or is freezing in the lines.	Hot/Warm - The refrigeration is not plugged in or turned on.	Plug in the refrigerator and assure it is powered on.
	Frozen - The thermostat on the refrigeration needs adjusted.	See control section
	The condenser coil on the refrigeration is dirty and needs cleaned.	See condenser cleaning

Control Operation

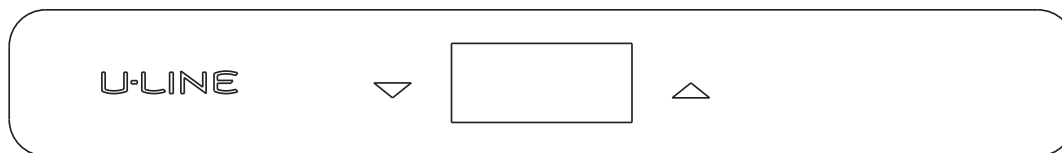

CONTROL FUNCTION GUIDE

FUNCTION	COMMAND	NOTES
ON/OFF	Press ▾ and hold for 5 seconds	Unit will turn On or OFF
Adjust Temperature	Press ▲ or ▾ and release	When the display is flashing, press ▲ or ▾ to adjust the set point temperature.
Toggle between °F / °C	Hold ▲ and ▾ for 5 seconds	The display will change units

Airflow and Product Loading

AIRFLOW

External

- Do not block the front grille - no additional clearance around sides, top or rear of unit is needed for ventilation
- Do not install behind a closed door

Internal

- When loading, leave space between internal fans, vents, and side walls to allow air to circulate freely

NOTICE

Restricting airflow may result in poor product performance, product failure, and uneven internal temperatures and may freeze contents.

Cleaning

CLEANING VS. SANITIZING

This guide will address both the cleaning and the sanitizing of the unit.

Clean the unit to remove dried food and spills, to prevent build-up of grime, and to maintain the natural luster stainless steel surfaces.

Sanitize the unit when exposed to raw meat juice or human germs such as from a sneeze or being touched by someone who is ill. Sanitizing the unit can also be part of regular cleaning routine.

Stainless Surfaces

Stainless door panels, handles and frames can discolor when exposed to chlorine gas, pool chemicals, saltwater or cleaners with bleach.

Keep your stainless unit looking new by cleaning with a good quality all-in-one stainless steel cleaner and polish monthly. For best results use Claire® Stainless Steel Polish and Cleaner. Comparable products are acceptable. Frequent cleaning will remove surface contamination that could lead to rust. Some installations may require cleaning weekly.

Do not clean with steel wool pads.

Do not use stainless steel cleaners or polishes on any glass surfaces.

Clean any glass surfaces with a non-chlorine glass cleaner.

Do not use cleaners not specifically intended for stainless steel on stainless steel surfaces (this includes glass, tile, and counter cleaners).

If any surface discoloring or rusting appears, clean it quickly with Bon-Ami® or Barkeepers Friend Cleanser® and a nonabrasive cloth. Always clean with the grain. Always finish with Claire® Stainless Steel Polish and Cleaner or comparable product to prevent further problems.

Using abrasive pads such as ScotchBrite™ will cause the graining in the stainless steel to become blurred.

Rust not cleaned up promptly can penetrate the surface of the stainless steel and complete removal of the rust may not be possible.

CLEAN INTERIOR COMPONENTS

Use warm or hot water with dish soap to clean all removed components and interior surfaces. You may use a vinegar and water solution in place of soap. Proceed to sanitizing.

Note: Cleaning soaps and vinegar solutions are not sanitizers.

SANITIZE INTERIOR COMPONENTS AND SURFACES

Choose a Commercial Sanitizer Safe for Stainless Steel

- Read the directions for proper use to ensure that the surface will actually be sanitized
- Many products require rinsing with water after use, especially when food will be touching the surface
- Some products require a wait time before rinsing
- Verify the sanitizer you are using is safe for stainless steel.

Mix Your Own Sanitizer

Isopropyl Alcohol (rubbing alcohol)

1. Fill a clean, empty spray bottle with isopropyl alcohol
2. Spray surface
3. Wait 20 minutes
4. Dampen a non-abrasive cloth with isopropyl alcohol and wipe down surface
5. Dry surface with a clean dry non-abrasive cloth

Unscented Bleach and Water

1. Create a solution of 1 tablespoon of unscented bleach with one gallon of water.
2. Submerge small parts for no more than 3 minutes - rinse immediately and allow to air dry or dry with a disposable paper towel.
3. Fill a clean, empty spray bottle with bleach solution.
4. Spray surface.
5. After 2-3 minutes, use clean potable water to thoroughly rinse off surface. Allow to air dry or dry with a disposable paper towel.
6. Sanitize the door and all holes where the hinges attach to the unit and the brackets attach to the door as well as all the screws.

CLEAN EXTERIOR SURFACES

Use Bon-Ami® or Barkeepers Friend Cleanser® and a nonabrasive cloth. Always clean with the grain. Always finish with Claire® Stainless Steel Polish and Cleaner or comparable product to prevent further problems.

INTERIOR CLEANING & SANITIZING

NOTICE

Do not use any solvent-based or abrasive cleaners. These types of cleaners may transfer taste and/or odor to the interior products and damage or discolor the interior.

Cleaning the Coffee-Dispensing System

The system should be cleaned each time you change your coffee tank and before extended periods of non use using a solution of water and ULACOFFEECLEAN. One packet of ULACOFFEECLEAN (Stera-Sheen®) was included with your product and more can be purchased at u-line.com.

Notice

Confirm system is not pressurized by turning off nitrogen – turn handle clockwise. Release pressure in system by pulling up on the release valve.



Cleaning Solution Preparation

Follow safety instructions on packet. Mix ULACOFFEECLEAN with 2 gallons of warm (100°F/38°C) potable water.



Tap Heads

Clean the tap heads with warm soapy water. Remove nose cones and soak in the cleaning solution for at least five minutes. Rinse with clean potable water, dry and reattach.



Infuser Filter

Disassemble by unscrewing the cap. Rinse cap and filter with warm potable water and reassemble.

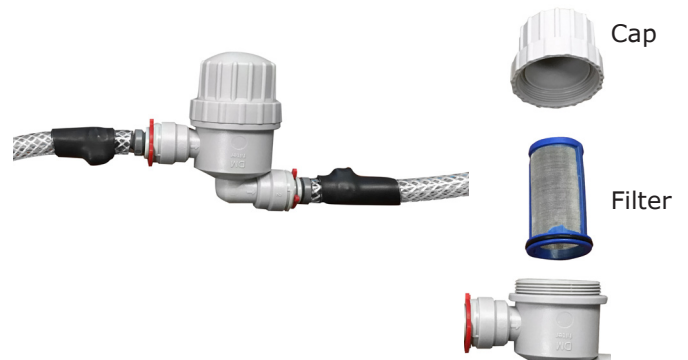

Line and System Cleaning

1. Remove the contents, clean the keg with water warm soapy water, and rinse.
2. Pour the cleaning solution into keg, attach hoses and open the nitrogen valve to pressurize the system.
3. Place a bucket under the taps. Pull and hold the left tap open until approximately ½ gallon of cleaning solution is dispensed. Close the left tap head. Pull and hold the right tap head handle until ½ gallon of solution is dispensed. Discard solution.
4. Allow the cleaning solution to remain in the system for a minimum of five minutes.
5. Dispense approximately ¼ gallon of the solution through the left tap. Dispense the remaining solution from the right tap. No rinsing is required.
6. Unless refilling, remove lid from keg to allow keg to air dry.

Cleaning the Beer-Dispensing System

Clean the system using a suitable solution designed for beer-dispensing systems. Beer cleaning kits are also available. Solution and/or kit not included.

1. Close CO₂ tank.
2. Pull pin on coupler to release pressure from keg.
3. Remove tap coupler from keg.
4. Remove CO₂ line from tap coupler.
5. Open tap coupler to allow cleaning solution to flow through it:
 - Push base of coupler inward and rotate clockwise.
6. Open cleaning pump.
7. Empty one packet of cleaner into plastic jar and fill with cool water.
8. Reassemble pump.

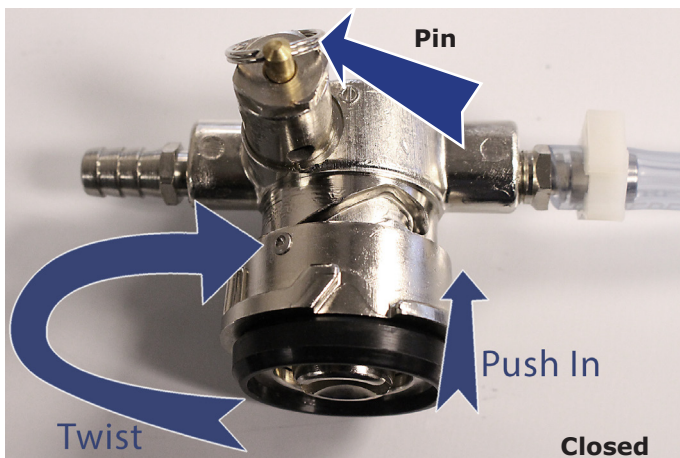

9. Remove tap head from tower with supplied tap head wrench. Disassemble, and place all the parts in drainage bucket.
10. Add washer and attach cleaning pump connector to tower. Tighten with tap head wrench.
11. Pump all the solution through the beverage line.
12. Allow tap coupler and tap head to soak in drainage bucket and then use tap head brush to clean tap head.
13. Rinse out and refill plastic jar with clean water. Pump all the water through the beverage line to rinse.
14. Rinse all disassembled parts with clean water.
15. Reassemble tap head and reconnect CO₂ and beverage lines.

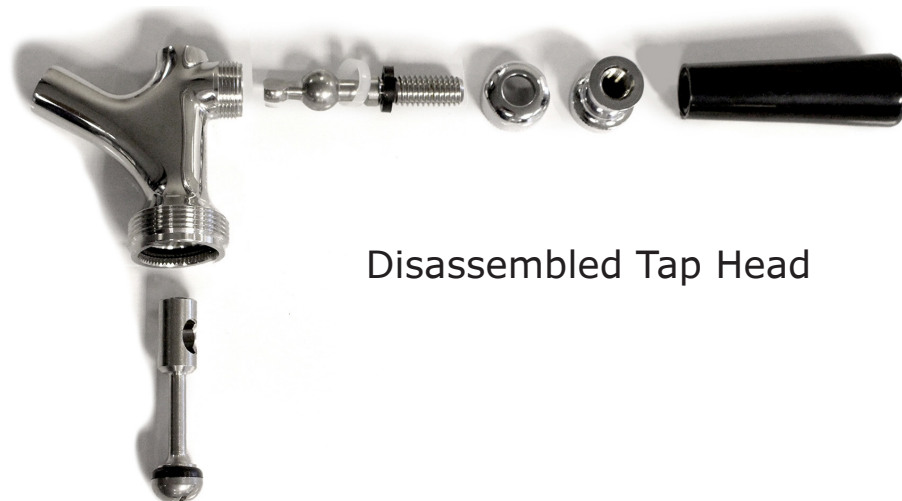
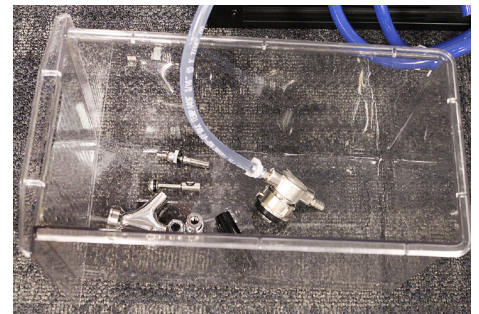

Disassembled Tap Head

DEFROSTING

Under normal conditions this unit does not require manual defrosting. Minor frost on the rear wall or visible through the evaporator plate vents is normal and will melt during each cycle.

If there is excessive build-up of 1/4" (6 mm) or more, manually defrost the unit.

Ensure the door is closing and sealing properly.

High ambient temperature and excessive humidity can also produce frost.



DO NOT use an ice pick or other sharp instrument to help speed up defrosting. These instruments can puncture the inner lining or damage the cooling unit. DO NOT use any type of heater to defrost. Using a heater to speed up defrosting can cause personal injury and damage to the inner lining.

NOTICE

The drain pan was not designed to capture the water created when manually defrosting. To prevent water from overflowing the drain pan and possibly damaging water sensitive flooring, the unit must be removed from cabinetry.

To defrost:

1. Disconnect power to the unit.
2. Remove all products from the interior
3. Prop the door in an open position (2 in. [50 mm] minimum).
4. Allow the frost to melt naturally.
5. After the frost melts completely, clean the interior and all removed components. (See INTERIOR CLEANING).
6. When the interior is dry, reconnect power and turn unit on.

Cleaning Condenser

INTERVAL - EVERY SIX MONTHS

To maintain operational efficiency, keep the front grille free of dust and lint, and clean the condenser when necessary. Depending on environmental conditions, more or less frequent cleaning may be necessary.

 **WARNING**

Disconnect electric power to the unit before cleaning the condenser.

NOTICE

DO NOT use any type of cleaner on the condenser unit. Condenser may be cleaned using a vacuum, soft brush, or compressed air.

1. Remove the grille. See GRILLE INSTALLATION).
2. Clean the condenser coil using a soft brush or vacuum cleaner.
3. Install the grille.

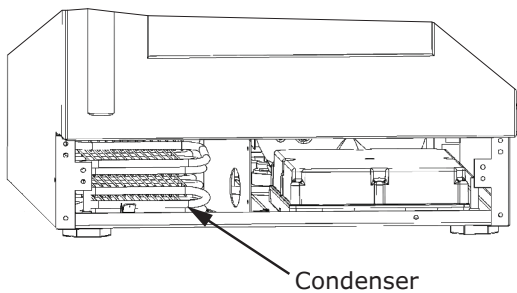

Extended Non-Use

VACATION/HOLIDAY, PROLONGED SHUTDOWN

The following steps are recommended for periods of extended non-use:

1. Remove all consumable content from the unit.
2. Disconnect the power cord from its outlet/socket and leave it disconnected until the unit is returned to service.
3. If any ice is visible inside the unit, allow ice to thaw naturally.
4. Clean and dry the interior of the unit. Ensure all water has been removed from the unit.
5. Clean the system. (See CLEANING)
6. The door must remain open to prevent formation of mold and mildew. Open door a minimum of 2" (50 mm) to provide the necessary ventilation.

WINTERIZATION

If the unit will be exposed to temperatures of 40°F (5°C) or less, the steps above must be followed.

For questions regarding winterization, please call U-Line at 414.354.0300.



Damage caused by freezing temperatures is not covered by the warranty.

Troubleshooting

BEFORE CALLING FOR SERVICE

If you think your U-Line product is malfunctioning, read the CONTROL OPERATION section to clearly understand the function of the control.

If the problem persists, read the NORMAL OPERATING SOUNDS and TROUBLESHOOTING GUIDE sections below to help you quickly identify common problems and possible causes and remedies. Most often, this will resolve the problem without the need to call for service.

IF SERVICE IS REQUIRED

If you do not understand a troubleshooting remedy, or your product needs service, contact U-Line Corporation directly at +1.800.779.2547.

When you call, you will need your product Model and Serial Numbers. This information appears on the Model and Serial number plate located on the upper right or rear wall of the interior of your product.

NORMAL OPERATING SOUNDS

All models incorporate rigid foam insulated cabinets to provide high thermal efficiency and maximum sound reduction for its internal working components. Despite this technology, your model may make sounds that are unfamiliar.

Normal operating sounds may be more noticeable because of the unit's environment. Hard surfaces such as cabinets, wood, vinyl or tiled floors and paneled walls have a tendency to reflect normal appliance operating noises.

Listed below are common refrigeration components with a brief description of the normal operating sounds they make. NOTE: Your product may not contain all the components listed.

- Compressor: The compressor makes a hum or pulsing sound that may be heard when it operates.

- Evaporator: Refrigerant flowing through an evaporator may sound like boiling liquid.
- Condenser Fan: Air moving through a condenser may be heard.
- Automatic Defrost Drain Pan: Water may be heard dripping or running into the drain pan when the unit is in the defrost cycle.

TROUBLESHOOTING GUIDE



ELECTROCUTION HAZARD. Never attempt to repair or perform maintenance on the unit before disconnecting the main electrical power.

Troubleshooting - What to check when problems occur:

Problem	Possible Cause and Remedy
Interior Light Does Not Illuminate	If the unit is cooling, it may be in Sabbath mode.
Light Remains on When Door Is Closed.	Turn off light switch if equipped. Adjust light actuator bracket on bottom of door.
Unit Develops Frost on Internal Surfaces.	Ensure the door is closing and sealing properly.
Unit Develops Condensation on External Surfaces.	The unit is exposed to excessive humidity. Moisture will dissipate as humidity levels decrease.
Product is Not Cold Enough	Air temperature does not indicate product temperature. See CHECKING PRODUCT TEMPERATURE below. Adjust the temperature to a cooler set point. Ensure unit is not located in excessive ambient temperatures or in direct sunlight. Ensure the door is closing and sealing properly. Ensure the interior light has not remained on too long. Ensure nothing is blocking the front grille, found at the bottom of the unit. Ensure the condenser coil is clean and free of any dirt or lint build-up.

CHECKING PRODUCT TEMPERATURE

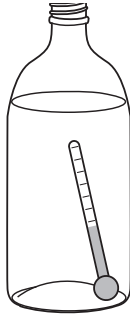

To check the actual product temperature in the unit:

1. Partially fill a plastic (nonbreakable) bottle with water.
2. Insert an accurate thermometer.
3. Tighten the bottle cap securely.
4. Place the bottle in the desired area for 24 hours.
5. Avoid opening the unit during the testing period.
6. After 24 hours, check the temperature of the water.
If required, adjust the temperature control in a small increment (see CONTROL OPERATION).

Causes which affect the internal temperatures of the cabinet include:

- Temperature setting.
- Ambient temperature where installed.
- Installation in direct sunlight or near a heat source.
- The number of door openings and the time the door is open.
- The time the internal light is illuminated. (This mainly affects product on the top rack or shelf.)
- Obstruction of front grille or condenser.

Wire Diagram

42376_C

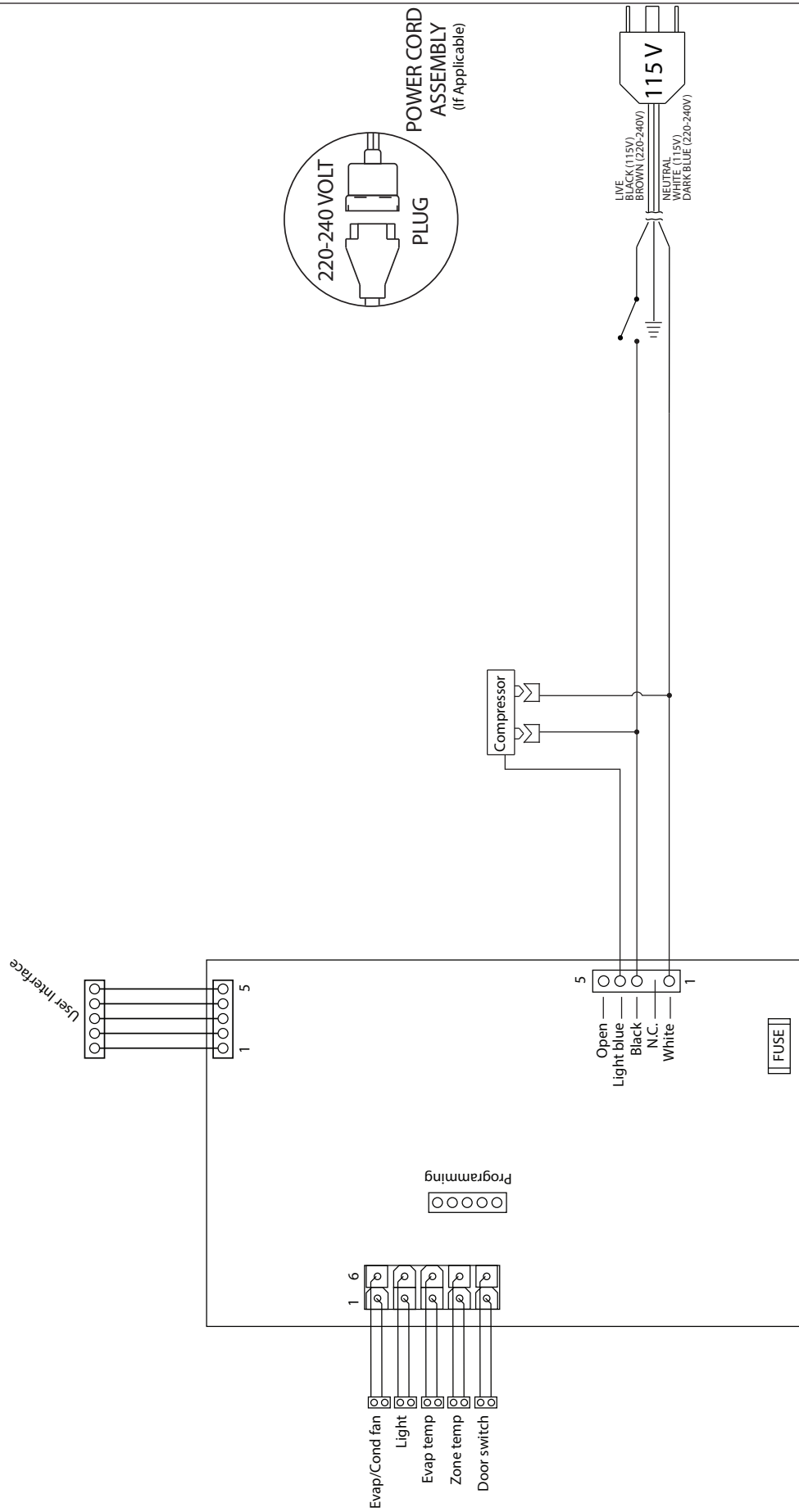

Product Liability

Field service technicians are authorized to make an initial assessment in the event of reported damages. If there are any questions about the process involved, the technician should call U-Line for further explanation.

While inspecting for defects or installation issues, photos should be taken to document any damages or issues found.

During the assessment, if the service technician is able to find the source of the damage and it can be resolved by replacement of a part, the servicer is authorized to replace the part in question. The part that caused the damage must be returned to U-Line in its entirety. The part must be clearly labeled with the serial number of the unit it was removed from, the date, and the servicer who removed the part.

If the service technician determines the damage is the result of installation issues (water connection/drain, etc.), the consumer would be notified and the issues shall be resolved at the direction of the consumer.

If damage is evident and the service technician is unable to find the source, U-Line must be contacted at 1.800.799.2547 for further direction.

8900 N. 55th Street • Milwaukee, WI 53223
T: +1.414.354.0300 • F: +1.414.354.5696
Website: www.u-line.com

**Right product. Right place.
Right temperature Since 1962.**

Warranty Claims

The following information defines the parameters for filing a warranty claim:

- Valid serial number needed
- Valid model number needed
- Claims must be submitted online at www.U-LineService.com
- 60 day submittal deadline from date of completed service
- Only one repair or unit per warranty claim
- Part order numbers will be required when submitting for warranty labor

Units must be registered prior to warranty submittal. Customers may register at www.U-Line.com. A proof of purchase is required. We also accept the following information to update warranty:

- New construction occupancy documents
- Closing paperwork
- Final billing - Remodel

Warranty parts will be shipped at no charge after U-Line confirms warranty status. Please provide the model, serial number, part number and part description. Some parts will require color or voltage information.

17 14862 05 0527
Year Factory Month Factory
 use Only use Only

Parts

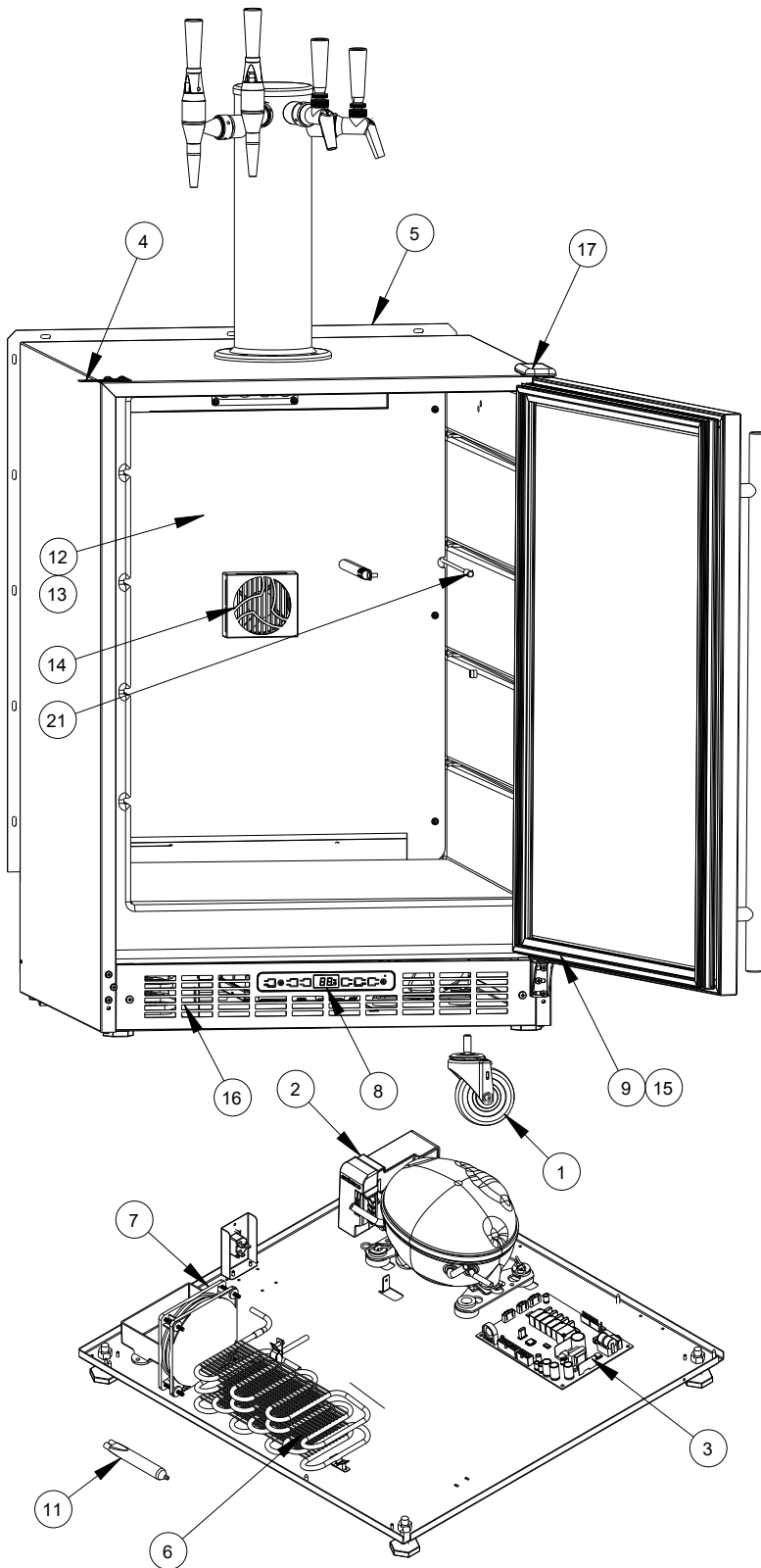

UCDE224ESS03A		
Item	Description	U-Line P/N
1	3" CASTERS (4)	ULACASTERS
2	COMPRESSOR ASSEMBLY	80-55548-00
3	MAIN BOARD	80-55507-00
4	ANTI TIP BRACKET W/SCREWS	80-54221-00
5	BACK PANEL, 24"	80-55350-03
6	CONDENSER ASSY 5 CLASS	80-55453-00
7	CONDENSER FAN W/SCREWS	80-54014-00
8	CONTROL ASSEMBLY	80-55552-01
9	DOOR ASSY, 24" SOLID STAINLESS	80-55421-01
10	DRAIN TROUGH 5 CLASS 24" *	80-55484-00
11	DRIER	80-54055-00
12	EVAP ASSY, 5 CLASS 24"	80-55486-00
13	EVAPORATOR COVER, BLACK	80-55554-00
14	EVAP FAN W/COVER, BLACK	80-54151-01
15	GASKET, DOOR	80-54213-01
16	GRILLE ASSEMBLY	80-55555-00
17	HINGE ASSEMBLY	80-55556-00
18	PACKAGING, 24" *	80-55557-00
19	POWER CORD, EXTERNAL *	80-55278-00
20	POWER CORD, INTERNAL *	80-55553-00
21	THERMISTOR(1 PC)	80-54006-00
22	WIRE HARNESS, OUTDR 1C *	80-55402-00

*Not Pictured

Ordering Replacement Parts

Parts may be ordered online at www.U-Line.com

See our contact information below:

www.U-LineService.com (with service login)

Phone Number: +1.414.354.0300

NOTICE

Use only genuine U-Line replacement parts. The use of non-U-Line parts can reduce speed of ice production, cause water to overflow from ice maker mold, damage the unit, and void the warranty.

Warranty parts will be shipped at no charge after U-Line confirms warranty status. Please provide the model, serial number, part number and part description. Some parts will require color or voltage information.

If U-Line requires the return of original parts, we will inform you when the parts order is taken. This requirement will be noted on your packing list. A prepaid shipping label will be emailed to you. Please enclose a copy of the parts packing list and be sure the model and serial numbers are legible on the paperwork. Tag the part with the reported defect.

Customers and non-authorized servicers may order non-warranty parts at www.u-line.com. Authorized servicers with a servicer login may order non-warranty parts at www.u-lineservice.com.

R-600A Specifications

For R-600a refrigerant service tips and more videos, go to: www.u-line.com/videos.



Flammability warnings for a pure-iso-butane refrigerant.



Gloves and Eye Protection must be used.



R-600a is considered non-toxic, but is flammable when mixed with air.

Keep a dry powder type fire extinguisher in the work area.



R-600a is heavier than air, do not allow any leakage/migration to low areas such as basements and stairs.

Never use a torch on a fully charged refrigeration system.

Never substitute U-Line OEM replacement parts or methods of construction.

R-600a must be stored and transported in approved containers.

⚠ WARNING

Only skilled and well trained service technicians permitted to service R-600a equipped products.

All tools and equipment must be approved for use with R-600a refrigerant.

Local, state and federal laws, standards must be observed along with proper certification and licensing.

Ventilation is required during servicing.

No conversions to R-600a from any other refrigerants. OEM R-600a equipped unit only.

Service area must be free of ignition sources.

No smoking is allowed in the service area.

All replacement electrical components must be OEM and installed properly (sealed and covered).

If the evaporator is cold prior to service, it must be thawed prior to service.

When using a vacuum pump, start pump before opening refrigeration system.

Vacuum pump and recovery equipment should be at least 10 feet from the work area.

It is recommended that a simple LPG gas detector is on site during service.

Ensure that all R-600a is removed from the system prior to brazing any part of the sealed system.

Only a clean, dry leak free system should be charged with R-600a.

R-600A SPECIFICATIONS/LABELING

R-600a equipped products are labeled (both the unit and the compressor).

R-600a is colorless and odorless.

R-600a is considered non-toxic, but is flammable when mixed with air.

Do not remove or alter any R-600a labeling on the product.

Use only a refrigerant grade R-600a from a properly labeled container.

RECOVERING/RECLAIMING R-600A

(R-600a has been exempted from recovery/reclaiming requirements by the US EPA)

Recovery/Reclaiming equipment must be approved for use with R-600a.

Ensure the evaporator is at room temperature prior to recovery/reclaiming R-600a.

Use a common piercing pliers or piercing valve to remove R-600a from the compressor process tube. (Note: Piercing devices must not be left on the system and must be replaced with a Schrader type valve.)

Evacuate/reclaim via the piecing pliers to ensure the system is empty of R-600a before any system work is performed.



The recovery cylinder must be evacuated (no air inside) prior to accepting R-600a.

The recovery cylinder must not be filled more than 45% safe fill level and refrigerants must not be mixed.

The recovery cylinder must be clearly marked with R-600a and Flammable Warning labels.

Ensure proper ventilation during recovery/reclaiming of R-600a.

Start vacuum pump/recovery pump prior to piercing the compressor process tube.

Follow recovery/reclaim OEM instructions for the specific equipment used.

SYSTEM REPAIR

Ensure no residual R-600a refrigerant is left within the system prior to repair (simple venting is not sufficient).

Evacuate and charge with dry nitrogen for leak checks.

Repair leaks or replace system parts as required.

When re-brazing, the system must be purged with dry nitrogen and at least one access point open to the atmosphere.

When re-brazing, proper ventilation is required along with constant monitoring for the presence of R600a refrigerant.

The filter dryer must be replaced any time the sealed system is serviced.

No system should be open to the atmosphere for longer than 15 minutes to avoid moisture migration into the system components.

LEAK DETECTION

After removal of the R-600a, the unit can be charged with dry nitrogen or helium.

Electronic leak detection or soap solution can be used to check for nitrogen/helium leaks.



Never use a halide torch or lighted match to check the system for leaks at any time.

The high side of the refrigeration system (compressor discharge to outlet of drier) must be leak tested with the compressor running.

The low side of the refrigeration system (evaporator, compressor and suction line) must be leak tested with the compressor off (equalized pressure).

RECHARGING

No air is ever to be allowed inside the refrigeration system (R-600a refrigerant or dry nitrogen only).

Never use a torch on a fully charged refrigeration system.

Install a Schrader Type access port on the compressor process stub.



Evacuate the system to 100 microns prior to charging.

Weigh in the R-600a charge using a refrigerant scale. (run compressor an extra two minutes to clear the charging hoses).

Seal the Schrader Type access port, a proper cap and seal must be used to close the system.



SUMMARY

Safely handling R-600a requires proper procedures and training.

R-600a approved service tools must be used.

R-600a labeling must not be removed or altered.

Proper ventilation during service is required.

Never apply a torch to a charged R-600a refrigeration system.

Use OEM replacement service parts and do not alter the construction of the unit.

System Diagnosis Guide

REGRIGERATION SYSTEM DIAGNOSIS GUIDE

System Condition	Suction Pressure	Suction Line	Compressor Discharge	Condenser	Capillary Tube	Evaporator	Wattage
Normal	Normal	Slightly below room temperature	Very hot	Very hot	Warm	Cold	Normal
Overcharge	Higher than normal	Very cold may frost heavily	Slightly warm to hot	Hot to warm	Cool	Cold	Higher than normal
Undercharge	Lower than normal	Warm-near room temperature	Hot	Warm	Warm	Extremely cold near inlet - Outlet below room temperature	Lower than normal
Partial Restriction	Somewhat lower than normal vacuum	Warm-near room temperature	Very hot	Top passes warm - Lower passes cool (near room temperature) due to liquid	Room temperature (cool) or colder	Extremely cold near inlet - Outlet below room temperature backing up	Lower than normal
Complete Restriction	In deep vacuum	Room temperature (cool)	Room temperature (cool)	Room temperature (cool)	Room temperature (cool)	No refrigeration	Lower than normal
No Gas	0 PSIG to 25"	Room temperature (cool)	Cool to hot	Room temperature (cool)	Room temperature (cool)	No refrigeration	Lower than normal

Compressor Specifications



Electrocution can cause death or serious injury. Burns from hot or cold surfaces can cause serious injury. Take precautions when servicing this unit.

Disconnect the power source.

Do not stand in standing water when working around electrical appliances.

Make sure the surfaces you touch are not hot or frozen.

Do not touch a bare circuit board unless you are wearing an anti-static wrist strap that is grounded to an electrical ground or grounded water pipe.

Handle circuit boards carefully and avoid touching components.

	FMXA9C
REFRIGERANT	R600A
VOLTAGE	230 VAC
FREQUENCY	43-134 Hz
START WINDING	20 Ohm at 77° F
RUN WINDING	20 Ohm at 77° F
RUN TO START	20 Ohm at 77° F
LRA	1.7 A
FLA	1.7 A
STARTING DEVICE	Inverter CF02C05
OVERLOAD	Inverter CF02C05

*All resistance readings are $\pm 10\%$

Troubleshooting - Extended

**CAUTION**

Never attempt to repair or perform maintenance on the unit until the main electrical power has been disconnected from the unit.

SPECIFIC ERRORS AND ISSUES

The advanced diagnostic capabilities of the electronic controls utilized on the 1, 3, and 5 Class units allow for easy and thorough troubleshooting.

Navigation of the control is the key and is explained in the CONTROL OPERATION section of the manual, along with control button layout, control function descriptions, a service mode menu and service menu selection explanations.

Verification of temperature and thermistor performance can be identified by directly viewing thermistor readings in the service mode.

Included in this section are some diagnostic tips and of course, if additional help is required, please contact the U-Line Corp, "Customer Care Facility" at +1.800.779.2547 for assistance.

NORMAL OPERATING SOUNDS

All models incorporate rigid foam insulated cabinets to provide high thermal efficiency and maximum sound reduction for its internal working components. Despite this technology, your model may make sounds that are unfamiliar.

Normal operating sounds may be more noticeable because of the unit's environment. Hard surfaces such as cabinets, wood, vinyl or tiled floors and paneled walls have a tendency to reflect normal appliance operating noises.

Listed below are common refrigeration components with a brief description of the normal sounds they make. NOTE: Your product may not contain all the components listed.

- Compressor: The compressor makes a hum or pulsing sound that may be heard when it operates.
- Evaporator: Refrigerant flowing through an evaporator may sound like boiling liquid.
- Condenser Fan: Air moving through a condenser may be heard.
- Automatic Defrost Drain Pan: Water may be heard dripping or running into the drain pan when the unit is in the defrost cycle.

Solenoid Valves: An occasional clicking sound may be heard as solenoid valves are operated.

TROUBLESHOOTING GUIDE

Concern	Potential Causes	Action
Not Cooling	Compressor overheating	Verify proper air flow through condenser. Is condenser clean? Confirm condenser fan operation.
	Compressor not operating	Test overload and relay, replace as needed.
	Compressor operating - no cooling	Refer to System Diagnosis Guide.
Frozen Product	Control set too cold	Adjust Set Point Temp accordingly.
	Thermistor failure	Check Error Log in Service Mode, OHM thermistor.
Frost Buildup Inside Unit	Door Ajar or Restricted from Closing	Check door clearance to adjoining cabinetry. Check distribution of product in unit.
	Thermistor failure	OHM thermistor
Display Not Working	Display unplugged	Verify that both ends of the display wiring are firmly connected.
	Display wiring broken or damaged	Perform continuity test of wiring and replace as needed.
Interior Lights Not Working	Door switch misaligned or defective	Check the function of reed switch and door magnet adjustment.
Noisy	Refrigeration tubing touching cabinet	Carefully reposition tubing.
	Fan blade obstruction (wiring, foam insulation, packaging material)	Remove obstruction.

MAIN CONTROL

The main control board is very robust and is rarely the cause of system issues. It is important to fully diagnose the board for any suspected failures before attempting to remove the board for replacement or service. Follow the guidelines below to fully test and diagnose the main control.

Power Fault

If the unit does not (or seems to not) power on, follow the flow chart below to help diagnose the issue. Before beginning it is important to first verify the unit is not simply set to sabbath mode.

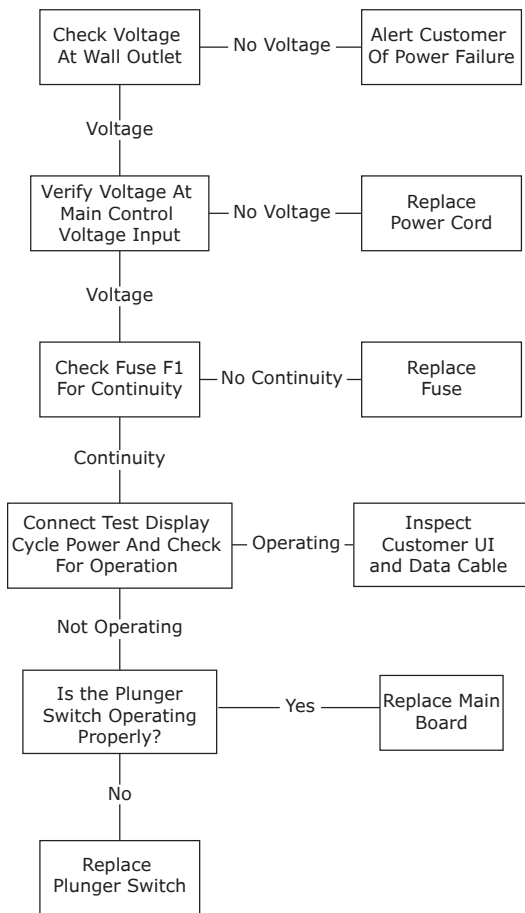

⚠ CAUTION

Precautions must be taken while working with live electrical equipment. Be sure to follow proper safety procedures while performing tests on live systems.

PLUNGER SWITCH

A plunger switch is used to monitor door state. When the door is closed it comes into contact with the plunger which closes a circuit which turns the light and display off. When the door is open the plunger moves outward and opens the circuit. If the door is left open for longer than 5 minutes the switch will trigger an error code and set an audible warning.

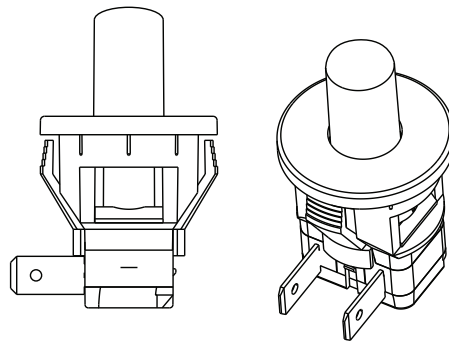

Control Operation-Service

UI BUTTON LAYOUT

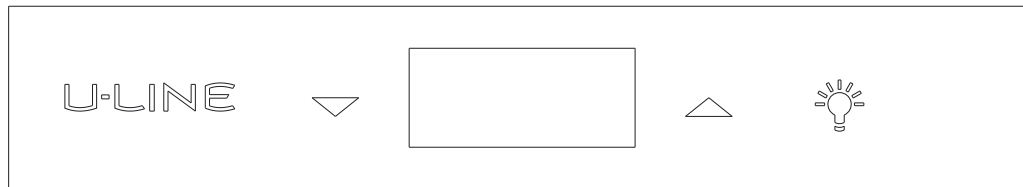

1. Up Button

- Increases temperature
- Navigates through service menu
- LED activated with button activation











2. Down Button

- Decreases temperature
- Navigates through service menu
- LED activated with button activation

3. Light Button

- Activates light for 3 hours on select models
- Used to select items in service menu
- LED activated with button activation

CONTROL FUNCTION GUIDE

FUNCTION	COMMAND	NOTES
Defrost Duration	Enter menu by pressing  for more than 5 seconds. Use  or  to increase/reduce defrost duration. Press  to select.	Display shows "df" (defrosting). This controls how long the unit defrosts.
Defrost Period	Press  once again. Use  or  to increase/reduce defrost period. Press  again.	Display shows the interval in which the unit defrosts in hours.
Set Offset Temperature	Use  or  to increase/reduce temperature.	Each adjustment for this setting is 1 degree: Positive = colder Negative = warmer
Exit Menu	Press  and release	

Thermistors

Thermistors are used for various temperature readings. Thermistors provide reliable temperature readings using a resistance which varies based on surrounding temperatures. If a faulty thermistor is suspected it may be tested using an accurate ohmmeter.

Both thermistors in the unit are identical. If a thermistor is suspected of being defective, the resistance can be verified. Place the thermistor in an ice water bath, the resistance should read 16.1k Ohms +/-5% on your meter.

Thermistor connections must be kept clean. A thermistor connection that has become corroded can cause resistance values from the thermistor to change as they pass through a dirty connection to the board.

It is for that reason that we apply dielectric grease to all of our thermistor connections. Dielectric grease will help to keep thermistor connections clean and dry.

If you change a thermistor in the unit please re-apply dielectric grease to the connection. If you encounter a dirty thermistor connection, you should replace the thermistor and the thermistor harness.

Thermistor error information can be found in the Control Operations - Service section.

This unit has **one** thermistor.

Thermistor one (Zone):

Located along the right hand side wall. It is used to maintain the operating temperature within that zone.

THERMISTOR FAILURE

Zone Thermistor

If the zone thermistor in the unit fails, the unit will continue to cool in a backup mode (Self Preservation Mode) to preserve the integrity of the contents. The unit will otherwise operate normally.

Thermistor Resistance Data

Temp (F)	Temp (C)	Nominal Resistance (OHMS)*
-40	-40	169157
-31	-35	121795
-22	-30	88766
-13	-25	65333
-4	-20	48614
5	-15	36503
14	-10	27681
23	-5	21166
32	0	16330
41	5	12696
50	10	9951
59	15	7855
68	20	6246
77	25	5000
86	30	4029
95	35	3266
104	40	2665
113	45	2186
122	50	1803
131	55	1495
140	60	1247
149	65	1044
158	70	879
167	75	743
176	80	631

* (+/- 5%)

Defrost

Outdoor units defrost every 12 hours of compressor runtime for 45 minutes. If you have verified that the unit does not have an ambient air leak, utilize the **Control Operation - Service** section and adjust unit to defrost every 9 hours for 60 minutes

Remove Fan and Cover

CONVECTION COOLING

This unit is equipped with an advanced convection cooling system. Convection cooling stabilizes cabinet temperature, cools product faster and increases energy efficiency.

Evaporator Fan

The evaporator fan is responsible for circulating warm air from the refrigeration zone, past the evaporator and back into the refrigerated zone.

The evaporator fan is factory set to have a 1 minute delay at the beginning of a cooling cycle. This delay gives the evaporator time to cool properly before warm air is passed over it. The fan will continue to run for an additional 2 minutes at the end of a cooling cycle. Fan delay times can be modified through the service menu.

Evaporator fan operation is also determined by door switch state. If the door switch circuit opens, the fan will stop. When the door switch circuit is closed the fan will either continue running with the cooling cycle, or if not currently cooling, the fan will run for 1 minute to circulate air and clear any condensation that may have appeared on glass doors and shelves.

Note: If the unit is set to sabbath mode, the evaporator fan will no longer respond to the state of the door switch.

In order to operate efficiently, the evaporator fan blade and vents should be unobstructed and free of any dust buildup.

Evaporator Fan Replacement

Should the evaporator fan need to be replaced follow the steps below.

1. Remove any product from the unit.
2. Remove unit from cabinetry to access rear.
3. Disconnect power to the unit.
4. Remove back panel from unit.
5. Disconnect fan electrical connection at rear of unit.

6. Remove insulating foam from refrigerant line pass-through hole as needed to gain clearance for fan plug.
7. Remove internal shelving.
8. Remove rear shelf clips, fronts can remain.
9. Remove thermistor cover.
10. Remove two evaporator cover screws from top of evaporator plate.

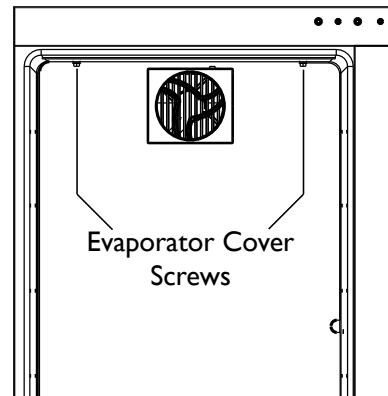

11. Grasp evaporator cover, pull forward and up as bottom of cover is installed behind the front edge of the drain trough.
12. While pulling the evaporator cover clear of the unit, it may be necessary to use your free hand to manipulate the fan plug end through the pass-through hole.
13. Remove the 4 screws mounting the fan shroud to the evaporator plate.

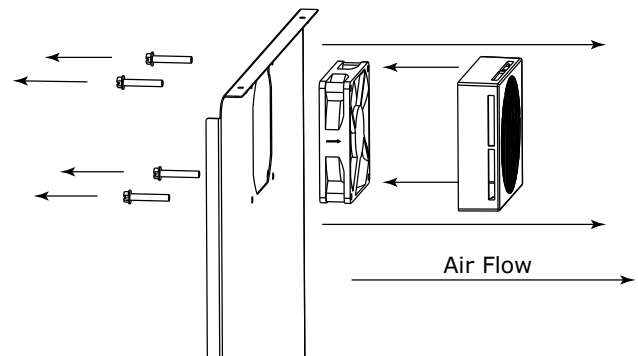

14. Remove and replace fan. Take special care to properly route fan wire.

NOTICE

Fan must be oriented to pull air in through lower evaporator cover vents and push air out at fan mounting location.

15. Installation is the reverse of removal.
16. Care must be taken to assure the bottom of the evaporator cover is reinstalled behind the front edge of the train trough.
17. Use sealant gum to seal any openings at rear of unit before replacing rear cover.
18. Reinstall unit taking care to level, space and secure as found.

U-Line Corporation (U-Line) Limited Warranty

One Year Limited Warranty

For one year from the date of original purchase, this warranty covers all parts and labor to repair or replace any part of the product that proves to be defective in materials or workmanship. For products installed and used for normal residential use, material cosmetic defects are included in this warranty, with coverage limited to 60 days from the date of original purchase. All service provided by U-Line under the above warranty must be performed by a U-Line factory authorized servicer, unless otherwise specified by U-Line. Service provided during normal business hours.

Two Year Limited Warranty (5 Class Product)

For two years from the date of original purchase, this warranty covers all parts and labor to repair or replace any part of the product that proves to be defective in materials or workmanship. For products installed and used for normal residential use, material cosmetic defects are included in this warranty, with coverage limited to 60 days from the date of original purchase. All service provided by U-Line under the above warranty must be performed by a U-Line factory authorized servicer, unless otherwise specified by U-Line. Service provided during normal business hours.

Available Second & Third Year Limited Warranty

In addition to the standard one and two year warranties outlined above, U-Line offers a one year extension of the warranties from the date of purchase, free of charge. To take advantage of this extension, you must register your product with U-Line within 60 days from the date of purchase at u-line.com and provide proof of purchase.

Five Year Sealed System Limited Warranty

For five years from the date of original purchase, U-Line will repair or replace the following parts, labor not included, that prove to be defective in materials or workmanship: compressor, condenser, evaporator, drier, and all connecting tubing. All service provided by U-Line under the above warranty must be performed by a U-Line factory authorized servicer, unless otherwise specified by U-Line. Service provided during normal business hours.

Terms

These warranties apply only to products installed in any one of the fifty states of the United States, the District of Columbia, or the ten provinces of Canada. The warranties do not cover any parts or labor to correct any defect caused by negligence, accident or improper use, maintenance, installation, service, repair, acts of God, fire, flood or other natural disasters. The product must be installed, operated, and maintained in accordance with your product's User Guide.

The remedies described above for each warranty are the only ones that U-Line will provide, either under these warranties or under any warranty arising by operation of law. U-Line will not be responsible for any consequential or incidental damages arising from the breach of these warranties or any other warranty, whether express, implied, or statutory. Some states do not allow the exclusion or limitation of incidental or consequential damages, so the above limitation or exclusion may not apply to you. These warranties give you specific legal rights, and you may also have other rights which vary from state to state.

Any warranty that may be implied in connection with your purchase or use of the product, including any warranty of *merchantability* or any warranty *fit for a particular purpose* is limited to the duration of these warranties, and only extends to five years in duration for the parts described in the section related to the five year limited warranty above. Some states do not allow limitations on how long an implied warranty lasts, so the above limitations may not apply to you.

- The warranties only apply to the original purchaser and are non-transferable.
- The second, third, and five year warranties cover products installed and used for normal residential or designated marine use only.
- The warranties apply to units operated outside only if designed for outdoor use by model and serial number.
- U-Line Commercial products are covered by the one year and 5 year limited warranties and are not eligible for the second and third year limited warranties.
- Replacement water filters, light bulbs, and other consumable parts are not covered by these warranties.
- The start of U-Line's obligation is limited to four years after the shipment date from U-Line.
- In-home instruction on how to use your product is not covered by these warranties.
- Food, beverage, and medicine loss are not covered by these warranties.
- If the product is located in an area where U-Line factory authorized service is not available, you may be responsible for a trip charge or you may be required to bring the product to a U-Line factory authorized service location at your own cost and expense.
- Units purchased after use as floor displays, and/or certified reconditioned units, are covered by the limited one year warranty only and no coverage is provided for cosmetic defects.
- Signal issues related to Wi-Fi connectivity are not covered by these warranties.

For parts and service assistance, or to find U-Line factory authorized service near you, contact U-Line:
8900 N. 55th Street, Milwaukee, WI 53223 • u-line.com • onlineservice@u-line.com • +1.414.354.0300