



SUPER BATTER / SIFTER CART

OPERATION, MAINTENANCE & REPAIR



302 Spencer Lane - P.O. Box 5369

San Antonio, TX 78201

(800) 525-8130 - (210) 731-5000 - Fax: (210) 731-5099

<http://www.ultrafryer.com>

PREFACE

This Manual was written and published by the Engineering Department, Ultrafryer Systems for use by personnel who will operate a Batter / Sifter Cart.

**ENGINEERING DEPARTMENT
ULTRAFRYER SYSTEMS
302 SPENCER LANE
SAN ANTONIO, TX 78201**

INDEX

PART ONE

GENERAL INFORMATION

	Page
INTRODUCTION	2
SAFETY	2
BATTER / SIFTER CART SETUP	2
SIFTER/BASKET ASSEMBLY REMOVAL/REPLACEMENT	3
BATTER/SIFTER CART SET-UP	5
PRINCIPLES OF OPERATION	5
WARRANTY	7

PART TWO

PREVENTIVE MAINTENANCE AND TROUBLE SHOOTING

INSPECTION REQUIREMENTS	9
LUBRICATION REQUIREMENTS	9
CLEANING	10
TROUBLE SHOOTING CHART	11

PART THREE

MAINTENANCE AND REPAIR

ELECTRICAL SYSTEM	13
ELECTRICAL COMPONENTS	
ELECTRICAL PLUG	14
ELECTRICAL CORD	15
TOGGLE ON/OFF SWITCH	15
RED POWER INDICATOR LAMP	16
FLOUR BIN INTERLOCK SWITCH	16
MECHANICAL COMPONENTS	
SIFTER MOTOR V-BELT	17
SIFTER MOTOR	17
SIFTER MOTOR PULLEY	18
SIFTER ACTIVATOR BAR CAM	19
SIFTER ACTIVATOR BAR	19
SIFTER MECHANISM SHAFT	20
SIFTER MECHANISM SHAFT PULLEY	20
PILLOW BLOCK	20
RUBBER SHAFT SEAL	20
BATTER/SIFTER CART CASTERS	21

PART FOUR

PARTS LIST AND SUPPLY

TECHNICAL ASSISTANCE, ORDERING INFORMATION AND PARTS IDENTIFICATION	23
BATTER/SIFTER CART COMPONENTS	24
SIFTER MECHANISM ASSEMBLY	26
TOGGLE ON/OFF SWITCH PLATE	

PART ONE
GENERAL INFORMATION

INTRODUCTION

The Batter/Sifter Cart shown to the right was designed by Ultrafryer Systems to operate as a heavy duty commercial breading cart incorporating a motorized sifter and doughball separator manufactured by the Reece Manufacturing Company. The Batter / Sifter Cart will serve as a central preparation station for breading assorted fried products such as chicken, nuggets, seafood, etc. in a store. The fast and quiet sifter and doughball separator mechanism in each cart performs these routine operations with maximum efficiency; and the “Dip-N-Flip” dipper basket and automatic flour sifter provides the handiest, breading station imaginable.

The Batter / Sifter Cart was designed for use in a small store with limited kitchen space. It is 29” (737 mm) deep, 24” (610 mm) wide with a work height of 36” (914 mm) and an overall height of 55 3/4” (1416 mm). The Cart is constructed from 16 and 18 gauge type 304 stainless steel and is equipped with 4” (102 mm) high swivel casters and a retractable electrical spring cord which allows the Batter/Sifter Cart to be easily moved from fryer to fryer. The 120 volt 60 hertz, 5 ampere dust proof sifter motor is located in a sealed compartment at the rear of the cart and is controlled by a sifter motor Toggle ON/OFF switch located in the upper right corner of the cart, along with a **RED** Power Indicator lamp. All components of the Sifter Basket Assembly are easily disassembled for cleaning without use of tools.



SAFETY

The Batter/Sifter Cart operates on 120 volt single phase electrical power and **NO CLEANING, REPAIR or ADJUSTMENT** to any component should be attempted without **FIRST** disconnecting electrical power. The electrical cord and plug are internally grounded and **MUST** be replaced with the identical item identified in the Parts List and Supply section of this manual. **PRIOR** to operating the Batter/Sifter Cart, **ENSURE** the Doughball Separator and Sifter Basket have been properly installed and are **SECURED**. Never turn the Batter/Sifter Cart **ON** or **OFF** with wet hands or while standing in water. Failure to follow these precautions, could result in serious injury, electrical shock or **DEATH**.

BATTER / SIFTER CART SET-UP

NOTE: Upon delivery or major repair of a Batter/Sifter Cart remove all components and **THOROUGHLY**; clean all metal surfaces and each component with **HOT** soapy water; rinse these items with water and dry all surfaces of each item with a soft dry cloth.

A. BATTER / SIFTER CART

The Batter / Sifter Cart consists of a **FLOUR SIFTER SECTION**, and **BATTER SECTION**. The Flour Sifter Section contains: 1) **SEALED SIFTER MOTOR ASSEMBLY**, 2) **SIFTER BASKET**, 3) **DOUGHBALL SEPARATOR**, 4) **FLOUR PAN W/8” (203 mm) DIAMETER OPENING**, 5) **FLOUR PAN SCRAPER/COVER**, 6) **FLOUR BIN**, and 7) **DOUGHBALL CATCH PAN** as shown below. The Batter Section shown on the next page contains the **BATTER PAN**, **BATTER COLD PAN**, and **DIP-N-FLIP DIPPER BASKET**.

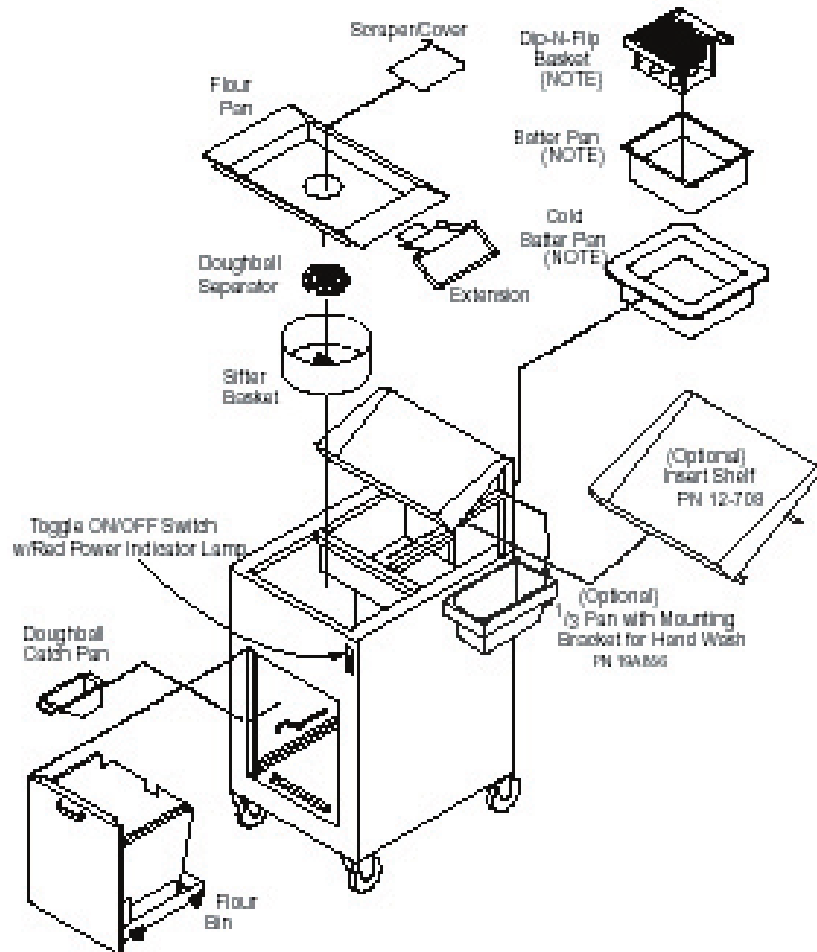

of the Batter Cart and
2AO80, which must be

1. **SIFTER BASKET ASSEMBLY REMOVAL/REPLACEMENT** - The Sifter Basket Assembly consists of the **DOUGHBALL SEPARATOR, SIFTER BASKET,** and **SIFTER BASKET SCREEN.** Remove, separate, reassemble and replace the Sifter Basket Assembly in the Batter/Sifter Cart as follows:

CAUTION: REMOVE THE TWIST LOCK ELECTRICAL PLUG FROM ITS RECEPTACLE “PRIOR” TO DISASSEMBLY OR REASSEMBLY OF THE BATTER / SIFTER CART.

a. Removal:

- 1) Remove the Flour Pan from the Batter / Sifter Cart, remove the “Dip-N-Flip” Basket, then remove the Batter Pan and Cold Batter Pan from the Batter / Sifter Cart.
- 2) Remove the Doughball Separator from the Sifter Basket as follows:

- a) Fully depress the **WHITE RELEASE KNOB**
- b) Turn the **WHITE RELEASE KNOB 90° (1/4 turn)** to the **RIGHT** to unlock the **PIN** from the Sifter Basket; then remove the plastic Doughball Separator from the Sifter Basket.

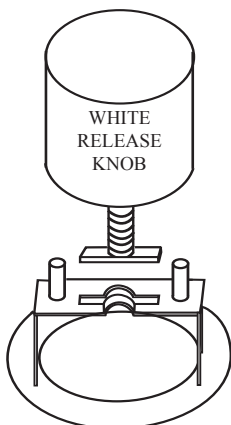
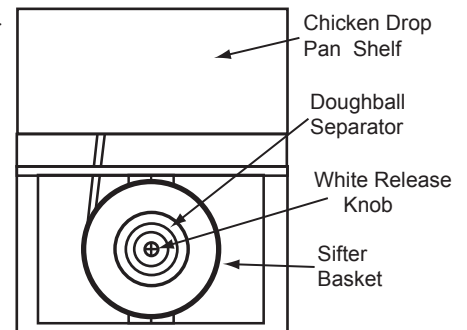
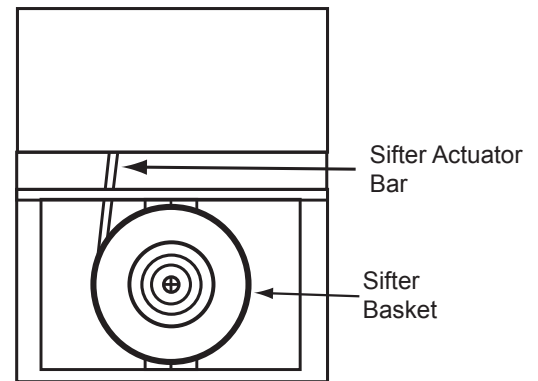

FIG. ILLUSTRATES UNLOCK POSITION

3) Remove the Sifter Basket from the Batter/Sifter Cart as follows:

- a) Locate the **SIFTER ACTIVATOR BAR** beneath the Sifter Basket with your **LEFT** hand.
- b) While holding the **SIFTER ACTIVATOR BAR**, **CAREFULLY**, insert fingers of your **RIGHT HAND** beneath the **CENTER** of the Sifter Basket, then lift the Sifter Basket **STRAIGHT** up and out of the cart.



CAUTION: DO NOT BEND THE SIFTER ACTIVATOR BAR UP OR DOWN WHILE REMOVING OR REPLACING THE SIFTER BASKET.

4) Remove the Sifter Basket Screen from the Sifter Basket as follows:

- a) Place the Sifter Basket **UPSIDE DOWN** on a clean flat surface.
- b) **CAREFULLY** press **DOWN** on the formed bottom of the Screen with finger tips until the Sifter Basket Screen drops out of the Sifter Basket.

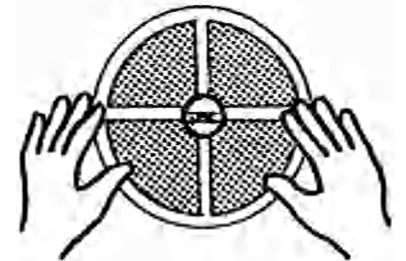

5) **CAREFULLY** remove the Flour Flow Cover from the **SIFTER BASKET BUSHING** by placing your finger tips beneath the cover and pulling **UPWARD**.

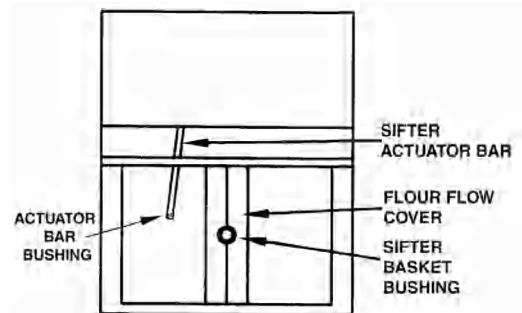

NOTE: The Sifter Basket is now disassembled for cleaning, inspection or maintenance.

b. Replacement

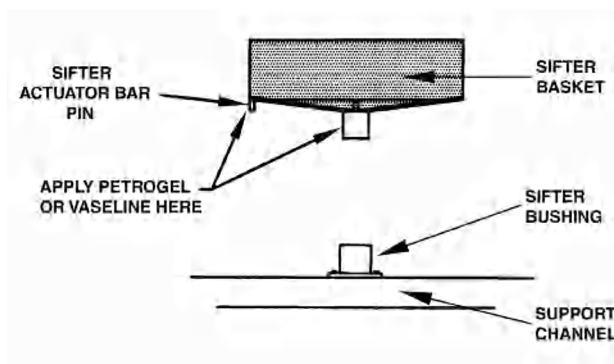

- 1) Place the Flour Flow Cover over the **SIFTER BASKET BUSHING**, then press **DOWNWARD** until the cover is seated.
- 2) Place the Sifter Basket **RIGHT SIDE UP** on a clean flat surface.
- 3) **CAREFULLY** insert the **SIFTER BASKET SCREEN** evenly into the Sifter Basket, then press **DOWN** on the screen with finger tips until the screen is **SEATED** in the Sifter Basket.
- 4) Apply a light coating of **PETROGEL**, or **VASELINE** to the Sifter Activator **PIN** and Sifter Basket **BASE** as shown to the left.
- 5) Insert the fingers of your **RIGHT** hand through the **CENTER BRACKET** of the Sifter Basket.

- 6) Position the Sifter Basket directly above the **SIFTER BASKET BUSHING**, grasp the Sifter Activator Bar with your **LEFT** hand and turn the Sifter Basket until the **PIN** is directly above the Sifter Activator Bar **BUSHING**, then **CAREFULLY** lower the Sifter Basket until the **BASE** and **PIN** are seated in their respective **BUSHINGS**.
- 7) Position the Doughball Separator above the Sifter Basket, orient the **LOCKING PIN** of the White Release Knob in the **CENTER** of the Sifter Basket **BRACKET** by turning the knob, then **SEAT** the Doughball Separator in the Sifter Basket and secure it by turning the **WHITE RELEASE KNOB 90°** (1/4 turn) to the **LEFT**.
- 8) Replace the Flour Pan, Batter Pan and “Dip-N-Flip” Basket in the Batter / Sifter Cart.
- 9) Replace the Electrical Plug in its receptacle.

2. BATTER / SIFTER CART SET-UP

- a. Install the **FLOUR FLOW COVER**, assemble and install the **SIFTER BASKET**, and **DOUGHBALL SEPARATOR**, according to procedures in step A 1 b on page 4.
- b. Open the **FLOUR BIN DRAWER** and insert the **DOUGHBALL CATCH PAN** beneath the Sealed Sifter Mechanism.
- c. Place the **FLOUR PAN**, with Scraper/Cover installed, in the opening above the Sifter Basket Assembly; position the **BATTER / SIFTER CART EXTENSION** in the Flour Pan; then fill the flour pan **TWO-THIRDS** full of flour.
- d. Install the **COLD BATTER PAN**, **BATTER PAN** and **DIP-N-FLIP BASKET**; then fill the Batter Pan **TWO-THIRDS** full of the applicable **CHILLED** and **STIRRED** Batter Mix.
- e. Place the “**PRODUCT**” **DROP PAN** on the **SLOPED** shelf above the Flour Pan, and begin breading the product to be cooked according to procedures in the Store Operations Manual.

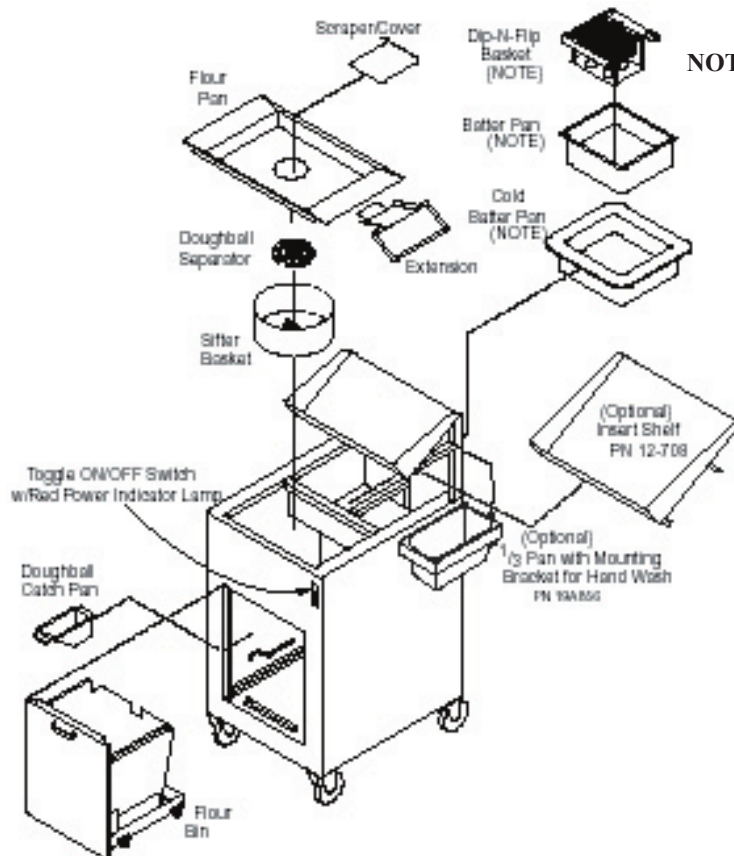

NOTE: This item is part of the Batter Cart & Cold Pan Kit, PN 12A080 which must be ordered separately

B. PRINCIPLES OF OPERATION

Each Batter/Sifter Cart is designed to serve as a central preparation station for breading Chicken, Nuggets, Seafood, and other, fried products. The cart is designed to operate in front of a Fryer, and the swivel casters and electrical spring cord allow the cart to be easily moved in front of each fryer. The flour bin is mounted on roller bearings and when opened, the bin tilts outward about 15° to make it convenient to scoop flour into the flour pan. The flour pan has a 8” (203 mm) opening in the center which is covered by a scraper/cover during the breading operation. When sufficient product for a fryer has been battered, the scraper is used to scrape “used” flour into the sifter basket located directly below the 8” (203 mm) opening and the sifter motor Toggle ON/OFF switch is pressed turning the motor **ON**. If more product is to be cooked immediately, flour can be scooped into the flour pan and the “used” flour can be sifted while breading product for another fryer. The flour bin is equipped with an **INTER-LOCK** switch which opens the electrical circuit to the sifter motor whenever the flour bin drawer is open. The sifter motor is designed for continuous operation; however it should be turned **OFF** after flour has been sifted for **TWO (2)** minutes. Refer to the applicable section of the Store Operating Manual for procedures in preparing batter mix, battering and cooking these foods. To produce a **QUALITY FRIED PRODUCT** it is essential that the Guidelines listed on the next page are followed:

GUIDELINES

1. Use **COLD BATTER MIX, SIFTED FLOUR** and **PROPER SHORTENING TEMPERATURE** for each product.
2. Sift flour for one (1) or two (2) minutes after each **PRODUCT DROP**.

NOTE: To avoid **CONTAMINATION**, **DO NOT** place sifted flour into the Flour Barrel and **DO NOT** mix Chicken and Seafood sifted flour together.

3. When flour has been sifted after each product drop, empty the **DOUGHBALL CATCH PAN**.
4. Perform the following tasks between product drops:
 - a. **SIFT FLOUR**
 - b. **EMPTY THE DOUGHBALL CATCH PAN**
 - c. **SKIM THE FRYER SHORTENING**

ULTRAFRYER SYSTEMS ASSOCIATED EQUIPMENT WARRANTY

Ultrafryer Systems warrants to the original purchaser of the BATTER/SIFTER CART, CHUB WARMER, PRODUCTION COUNTERS, and EXPEDITE STATIONS sold within the United States, its territories and Canada, that it will be free of defects in material and workmanship for the period listed below:

PARTS WARRANTY – Parts are covered for a period of one (1) year from the initial start up date. Ultrafryer Systems reserves the right to charge for certain parts that exceed the price of \$100.00 until the defective part is returned to Ultrafryer. After inspection, and a determination is made that the defect is not the result of neglect or abuse a credit will be issued to the equipment owner's account. All parts are to be shipped back to Ultrafryer Systems, **ATTN: WARRANTY DEPARTMENT**, and **prepaid by the customer**.



QUARTZ LAMPS – The QUARTZ LAMPS that are supplied with WARMERS are NOT under any warranty with Ultrafryer Systems.

PROCESSING WARRANTY CLAIMS – The equipment owner must promptly notify Ultrafryer Systems Warranty Department of any alleged defects as soon as discovered by calling 800-525-8130. After such notice, the Warranty Department will perform its obligation under this warranty within a commercially reasonable period of time. If alleged defects develop after normal business hours, on weekends, or holidays the owner must call Ultrafryer Systems first at the above number. This number is monitored 24 hours a day and 7 days a week. Ultrafryer Systems will notify an AUTHORIZED service agent to make repairs during normal hours and, if necessary, after normal working hours. Any repairs done **without AUTHORIZATION from Ultrafryer Systems** on equipment under the warranty is subject to non-payment by Ultrafryer Systems.

NON WARRANTY COVERAGE – This warranty does not include coverage for any consequential cost of damages including, but not limited to, any loss in store sales, spoiled food products, transportation, duty or custom cost. This does not cover original installation and adjustments such as leveling, calibrations, and electrical connections. This warranty does not cover travel over 100 miles or 2 hours drive time from the location of the BATTER/SIFTER CART, CHUB WARMER, PRODUCTION COUNTER, and EXPEDITE STATION, or overtime, or unauthorized repairs or installation, damage in shipment, and normal maintenance. This warranty does not cover any other equipment that may be supplied to the PRODUCTION COUNTER, or EXPEDITE STATION. **If a dealer supplies any accessories to the Ultrafryer Systems PRODUCTION COUNTER or EXPEDITE STATION, the owner must notify the dealer of any defects for repair or supply of any parts. Ultrafryer Systems reserves the right to void any component part warranty on the BATTER/SIFTER CART, CHUB WARMER, PRODUCTION COUNTER, and EXPEDITE STATION that is stored for more than 6 (six) months after shipment from Ultrafryer Systems and not put into service.**

LABOR COVERAGE – The cost for labor to replace parts or service the BATTER/SIFTER CART, CHUB WARMER, PRODUCTION COUNTER, and EXPEDITE STATION is covered for a period of one (1) year from the initial start up date. The warranty department must be promptly notified of any defects within the first year of operation. An AUTHORIZED service agent of Ultrafryer Systems will cover labor for repairs and service.

DISCLAIMER OF WARRANTIES

Other than as stated herein Ultrafryer Systems makes no warranty of any kind, express or implied, including but not limited to any warranty of merchantability of fitness or a particular purpose, including trade usage. Ultrafryer Systems sole obligation, and purchaser's sole remedy, under this warranty is repair or replacement, at the discretion of Ultrafryer Systems, of any part or component that proves to be defective in materials or workmanship. In no event shall Ultrafryer Systems be liable for consequential, incidental, or special loss or damages arising from the use of, or inability to use, the BATTER/SIFTER CART, CHUB WARMER, PRODUCTION COUNTER, and EXPEDITE STATION. There are no other documents or oral statements for which Ultrafryer Systems will be responsible.

PART TWO
PREVENTIVE MAINTENANCE AND TROUBLE SHOOTING

PREVENTIVE MAINTENANCE AND INSPECTION REQUIREMENTS

Although the Batter/Sifter Cart only requires minimal preventive maintenance, the need to keep it clean cannot be over-stressed. The pans, dipper basket, sifter basket assembly, and flour flow cover come in contact with food and **MUST** be periodically cleaned through-out the day and **THOROUGHLY** cleaned each evening. If the Batter/Sifter Cart is kept clean and if the following inspections are performed, this cart will provide many years of trouble-free service.

A. INSPECTION REQUIREMENTS

INSPECTION FREQUENCY				
ITEM & DESCRIPTION	DAILY	WKLY	MNTHLY	INSPECT FOR:
1. Electrical Plug, Cord & Sifter Motor Toggle ON/OFF Switch	<input checked="" type="checkbox"/>			Inspect Electrical Cord, Plug & Sifter Motor Toggle ON/OFF Switch for any physical damage. Replace damaged item according to instructions in Part Three of this Manual.
2. Sifter Basket Assembly		<input checked="" type="checkbox"/>		Inspect the Sifter Basket Scraper, Dough-ball Separator, & Sifter Basket for damage. Order replacement items according to procedures in Part Four of this Manual.
3. Sealed Sifter Motor Assembly			<input checked="" type="checkbox"/>	Inspect the V-Belt for wear; the Pulleys, Cam, Pillow Blocks & Sifter Activator Bar Shaft for damage. Order replacement items according to procedures in Part Four and replace defective items according to instructions in Part Three of this Manual.
4. Casters & Wheels		<input checked="" type="checkbox"/>		Check for free movement of casters and wheels for flat spots, and inspect for rust and corrosion. Remove rust and corrosion following the procedures below, and replace defective casters according to instructions in Part Three of this Manual.
5. Flour Bin Roller Bearings & Tracks			<input checked="" type="checkbox"/>	Inspect bearings of the flour bin drawer for free movement, and check bearings and tracks for accumulation of caked flour or other debris. Clean bearings and tracks according to procedures below.

B. LUBRICATION REQUIREMENTS

The two (2) Sifter Mechanism Shaft **PILLOW BLOCKS** are equipped with grease fittings and the **SIFTER MOTOR** has an **OIL PORT** for lubricating the motor bearings. The Pillow Blocks and Sifter Motor should be lubricated **EACH SIX (6) MONTHS** as follows:

1. PILLOW BLOCKS

- a. Remove the rear panel of the Batter/Sifter Cart.
- b. Remove the **GRAY** grease fitting cover from each Pillow Block and lubricate the bearing with **Alvania 02 Lithium Based Lubricating Grease**.

NOTE: USE a hand operated grease gun **ONLY** to grease these bearing as excessive grease pressure may damage the bearing seals.

- c. Wipe off any excessive grease from the grease fittings and replace the **GRAY** grease fitting covers.

2. SIFTER MOTOR

- a. Remove the YELLOW oil port cover from the Sifter Motor and lubricate the bearings with 10 to 20 drops of SAE 10W or 20W NON-DETERGENT or electric motor oil.
- b. Wipe off any excess oil around the oil port and then replace the YELLOW oil port cover.
- c. Replace the rear panel of the Batter/Sifter Cart.

As mentioned previously, it is ESSENTIAL that the Batter/Sifter Cart is kept CLEAN throughout the day and THOROUGHLY CLEANED at store closing as outlined below:

C. CLEANING

1. DAILY

- a. Prepare a 6 quart (5.7 liters) container of sanitizer and warm water, in the proper ratio, for use in cleaning soiled surfaces.
- b. After each product drop soak a cloth towel in the sanitizer solution, wring out the towel until it is damp and clean any soiled surface of the cart until it is THOROUGHLY clean and free of any flour residue.
- c. Perform the following cleaning routines at store closing:
 - 1) Remove and store batter mix according to procedures in the Store Operating Manual.
 - 2) THOROUGHLY clean all pans and allow them to air dry overnight.
 - 3) Remove the Sifter Basket Assembly, and Flour Flow Cover; disassemble the Sifter Basket Assembly and THOROUGHLY clean the Doughball Separator, Sifter Basket Screen, Sifter Basket and Flour Flow Cover.
 - 4) THOROUGHLY clean the interior Sifter Basket compartment using a WHISK BROOM and clean dry towels to remove all flour residue.

CAUTION: NEVER SPRAY THE INTERIOR SIFTER BASKET COMPARTMENT WITH WATER! WATER WILL SEEP INTO THE SIFTER MECHANISM CAUSING PARTS TO RUST.

- 5) After the Sifter Basket, Screen, Doughball Separator, and Flour Flow Cover are completely dry, reassemble the Sifter Basket Assembly and replace these items in the cart.
- 6) Prepare a NEW pan of sanitizer solution and THOROUGHLY clean all metal surfaces of the Batter/Sifter Cart with a dampened cloth towel then dry all surfaces with a soft dry cloth.
- 7) Use Stainless Steel Polish and polish all metal surfaces as follows:
 - a. Shake polish container gently.
 - b. Spray in a fine mist onto the surface to be cleaned and polished.
 - c. Wipe off with a handi-wipe in a circular motion.
 - d. For small hard to reach areas, spray directly onto the handiwipe and wipe the area.

2. WEEKLY

- a. Perform daily cleaning routines listed above.
- b. Place the SIFTER BASKET, and SIFTER BASKET SCREEN, in a fyer with BOIL-OUT SOLUTION for cleaning.
- c. After the Sifter Basket, and Sifter Basket Screen, have been cleaned. ENSURE they are THOROUGHLY sprayed with a solution of 1 PART vinegar to 25 PARTS water to NEUTRALIZE the boil-out solution; then allow these items to air dry.

3. MONTHLY

- a. The swivel casters require periodic cleaning and lubrication. If rust or corrosion becomes evident, clean the swivel casters with a wire brush and lubricate the caster and swivel joint with a few drops of SAE 30 motor oil.

- b. Remove the plastic flour bin; then remove the flour bin drawer. Remove any accumulation of flour on the roller bearings and tracks with a wire brush, and wipe these items clean with a DRY cloth.

CAUTION: DO NOT LUBRICATE ROLLER BEARINGS AND DO NOT USE WATER TO CLEAN BEARINGS OR TRACTS AS THIS WILL CAUSE FLOUR TO BUILD UP AND CAKE ON THESE ITEMS.

D. TROUBLE SHOOTING CHART

BATTER CART TROUBLE SHOOTING CHART		
<u>PROBLEM</u>	<u>PROBABLE CAUSE</u>	<u>CORRECTIVE ACTION</u>
Sifter Motor will not operate	<ul style="list-style-type: none"> A. Flour bin drawer open or defective interlock switch. B. Batter Cart electrical plug is not connected to electrical receptacle. C. Sifter Motor Toggle ON/OFF switch is in the OFF position. D. Circuit breaker in the main electrical panel tripped. E. Defective Sifter motor Toggle ON/OFF switch. F. Defective Motor. 	<ul style="list-style-type: none"> A. Close drawer or replace interlock switch. B. Connect plug to receptacle. C. Place the Toggle switch in the ON position. D. Reset circuit breaker & check for cause of tripped breaker. E. Replace the Toggle ON/OFF switch according to instructions in Part Three. F. Replace the motor according to instructions in Part Three.
Sifter Motor operates but Sifter Basket will not rotate	<ul style="list-style-type: none"> A. Sifter basket pin is not seated in sifter activator bar bushing. B. Defective sifter pulley or cam. C. Defective sifter pulley or cam. 	<ul style="list-style-type: none"> A. Re-install sifter basket according to paragraph A 1 b 6) on page 4). B. Replace belt according to instructions in Part Three. C. Replace Defective item according to instructions in Part Three.

PART THREE
MAINTENANCE AND REPAIR

MAINTENANCE AND REPAIR INSTRUCTIONS

Maintenance and repair instructions contained herein are based on the 2003 Batter/Sifter Cart. While these instructions may not completely apply to later models, they should be used as a guide in performing similar repairs on newer equipment unless advised otherwise in a technical publication.

Maintenance and repair of the Batter/Sifter Cart will be minimal if preventive maintenance is accomplished at the intervals prescribed in Part Two.

CAUTION: REMOVE ELECTRICAL POWER FROM THE BATTER SIFTER CART PRIOR TO REPAIRING ANY COMPONENT OF THE BATTER / SIFTER CART.

I. ELECTRICAL SYSTEM

The electrical system of the Batter/Sifter Cart consists of the Sifter Motor, Sifter Motor Toggle On/Off Switch **RED** Power Indicator Lamp and Flour Bin Interlock Switch which are electrically wired as shown below. Whenever the Batter/Sifter Cart electrical plug is connected to an electrical receptacle and the applicable circuit breaker is closed, 120 volts will be applied across the Black and White wires of electrical plug P1. In order for 120 volts to be applied to the Sifter Motor M1, the Sifter Motor Toggle On/Off Switch S1 must be placed in the **ON** position and the Flour Bin Drawer must be **CLOSED** which will depress the Flour Bin Interlock Switch S2. When switch S1 is placed in the ON position and the Flour Bin Interlock Switch S2 is **DEPRESSED**, the Sifter Motor will start operating the Sifter Mechanism.

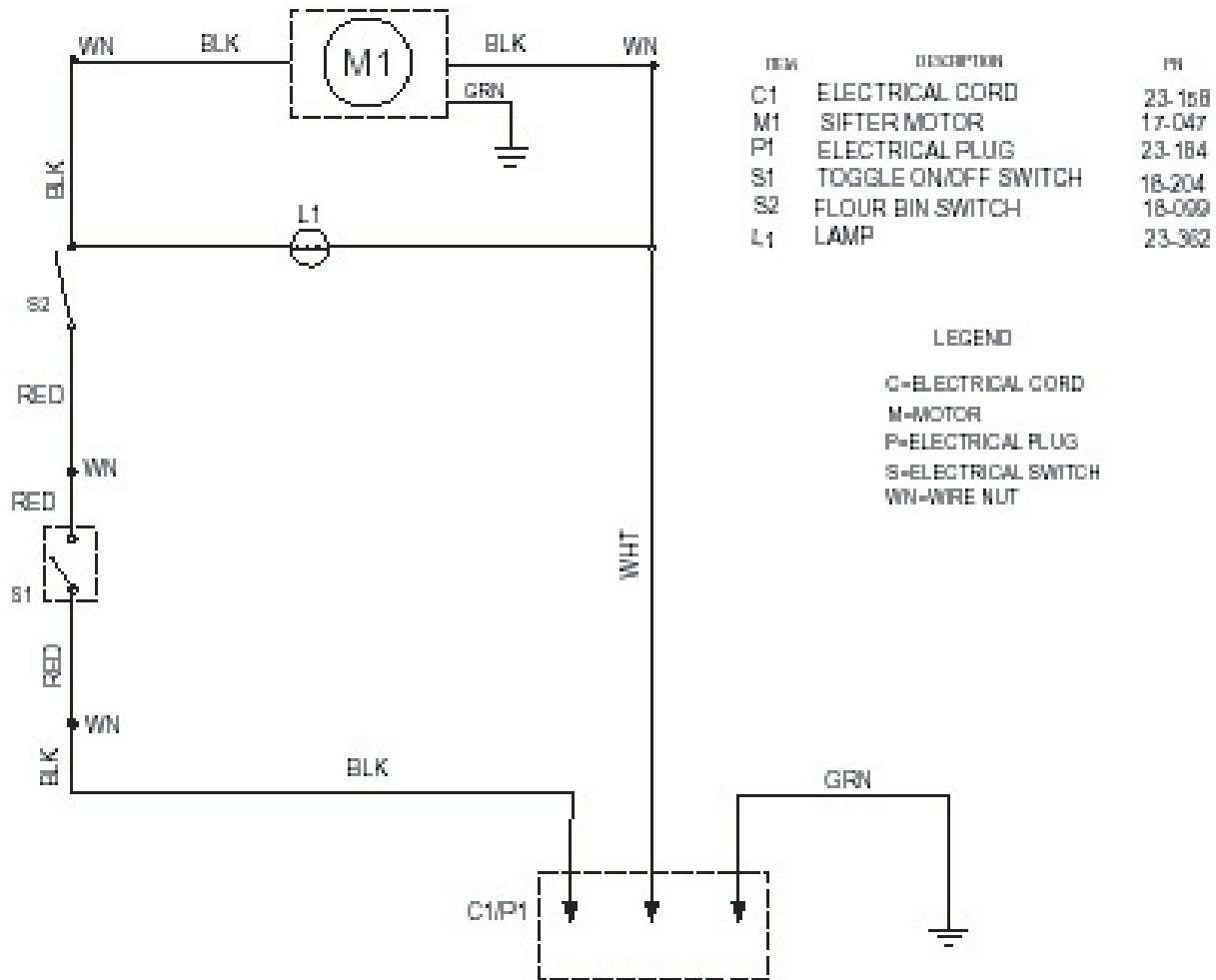

BATTER / SIFTER CART WIRING DIAGRAM
 PN 23A127

ELECTRICAL COMPONENTS

The Batter/Sifter Cart electrical components consist of a Hubbell HBL 4720C Twistlock Electrical Plug, three conductor Type SJO 18/3 coiled electrical cord, Toggle On/Off Electrical Switch, RED Power Indicator Lamp and Micro No. BZ2R555 -1 Flour Bin Interlock Switch. IF these items become defective, they should be replaced as follows:

CAUTION: REMOVE THE BATTER/SIFTER CART ELECTRICAL PLUG FROM THE ELECTRICAL RECEPTACLE PRIOR TO REPLACING ANY ELECTRICAL COMPONENT.

A. **BATTER/SIFTER CART ELECTRICAL PLUG** - A Hubbell HBL 4720C Twistlock electrical plug is attached to the Batter/Sifter Cart electrical cord.

To replace a Batter/Sifter Cart electrical plug:

1. Remove the Batter/Sifter Cart electrical plug from the electrical receptacle.
2. Insure the replacement electrical plug is a Hubbell HBL 4720C or substitute with a L5-15P NEMA reference.
3. Remove the WHITE Cord Grip from the black rubber cover by removing the two (2) screws.
4. Loosen the three (3) screws on the bottom of the electrical plug and separate the clear wiring chamber from the black rubber cover.
5. Loosen the three (3) terminal screws on the wiring chamber; then separate the three (3) electrical wires from the wiring chamber and slip the black rubber cover off of the electrical cord.
6. Slide the black rubber cover of the new electrical plug onto the electrical cord about 3" (76 mm) as shown below.
7. Loosen the three (3) terminal screws (BRASS, GREEN, & SILVER) on the NEW wiring chamber; then insert the bare portion of each electrical wire into a wire slot as follows:

NOTE: DO NOT TIN WIRES.

- a) Insert the wire with green insulation into the wire slot with a green terminal screw head.
 - b) Insert the wire with white insulation into the wire slot with a silver terminal screw head.
 - c) Insert the wire with black insulation into the wire slot with a brass terminal screw head.
8. When each wire is fully inserted in the proper wire slot securely tighten each terminal screw.
 9. CAREFULLY slide the black rubber cover down the electrical cord and onto the wiring chamber so that the KEY fits into the KEYWAY.
 10. With the black rubber cover properly installed on the wiring chamber; securely tighten the three (3) screws on the side of the wiring chamber.
 11. Replace the WHITE cord grip around the electrical cord and tighten the two (2) screws (alternating tightening) until the cord will not slip inside the cord grip.
 12. Connect the Batter/Sifter Cart electrical plug to the electrical receptacle and test operate the Sifter Mechanism.

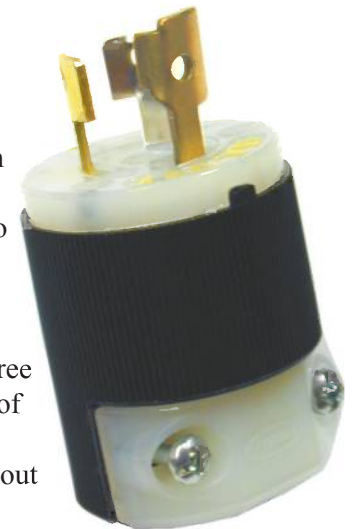

BATTER/SIFTER CART
ELECTRICAL PLUG
HUBBELL HBL 4720C
TWISTLOCK PN 23-184

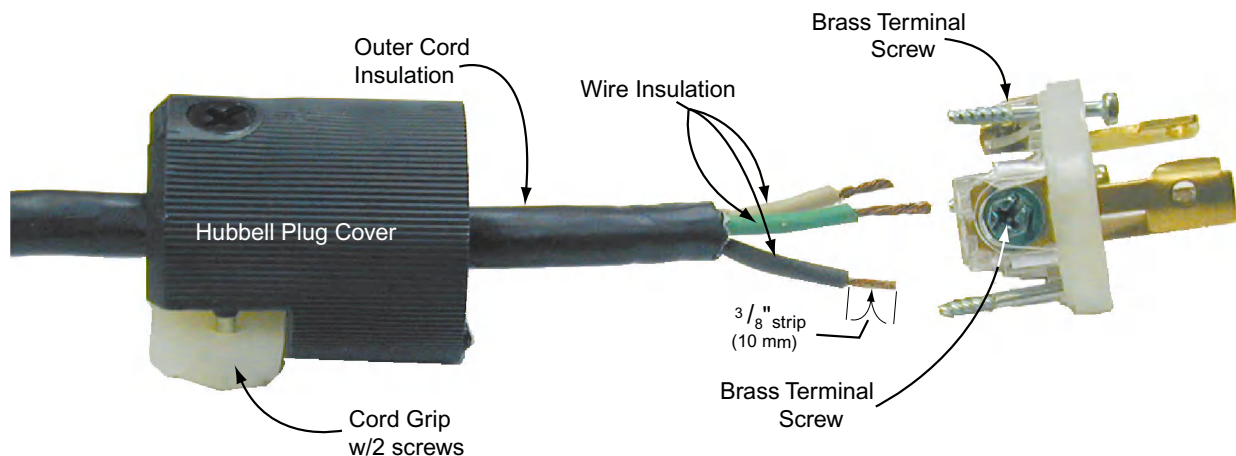

- B. **BATTER/SIFTER CART ELECTRICAL CORD** - A coiled 3 conductor 18 gauge type SJO electrical cord is used to provide electrical power to the Batter/Sifter Cart. If aged, it MUST be replaced with the identical cord or an equivalent cord recognized by Underwriters Laboratories (UL).

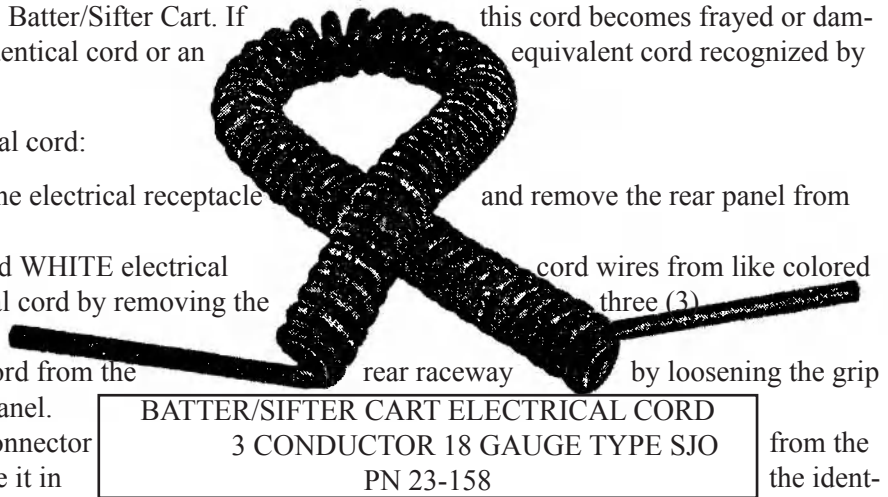

To replace a Batter/Sifter Cart electrical cord:

1. Remove the electrical plug from the electrical receptacle on the Cart.
2. Separate the BLACK, GREEN and WHITE electrical wires of the Sifter Motor Electrical cord by removing the wire nuts.
3. Remove the defective electrical cord from the rear raceway by loosening the grip connector hex fitting on the rear panel.
4. Remove the electrical cord grip connector from the defective electrical cord and locate it in the identical position on the new electrical cord.
5. Remove the Batter/Sifter Cart Electrical Plug from the defective electrical cord and install it on the new electrical cord following procedures contained in step A3 through step A11 on the previous page.
6. Remove 15/16" (24 mm) of OUTER insulation from the end of the new electrical cord; then remove 9/16" (14 mm) of insulation from the BLACK, GREEN and WHITE electrical wires.
7. Insert the new electrical cord and grip connector in the bushing on the rear panel, and secure the grip connector to the bushing by tightening the hex fitting.
8. Securely connect the BLACK, GREEN and WHITE electrical cord wires to like colored wires of the Sifter Motor electrical cord using the three (3) wire nuts removed in step 2 above.
9. Connect the Batter/Sifter Cart electrical plug to the electrical receptacle and test operate the Batter/Sifter Cart.
10. If the Batter/Sifter Cart operates properly, replace and secure the rear panel.

- C. **BATTER/SIFTER CART TOGGLE ON/OFF SWITCH** - A single pole, single throw (SPST) Toggle Switch is used to turn the power to the Batter/Sifter Cart ON and OFF. If the switch becomes defective it MUST be replaced with an identical switch.

To replace a Sifter Motor Toggle ON/OFF Switch:

1. Remove the Batter/Sifter Cart electrical plug from the electrical receptacle; and remove the Flour Pan, and Sifter Basket Assembly.
2. Remove the 6" x 9" (152 x 229 mm) cover plate from the sifter motor toggle ON/OFF switch compartment by removing the four (4) 10-24 x 1/2" (13 mm) truss head screws.
3. Remove the GRAY Protective Rubber Boot from the defective switch; then remove the 7/16" (11 mm) HEX NUT from the defective toggle ON/OFF switch.
4. CAREFULLY remove the defective switch from the switch mounting plate and remove it from the SWITCH COMPARTMENT opening.

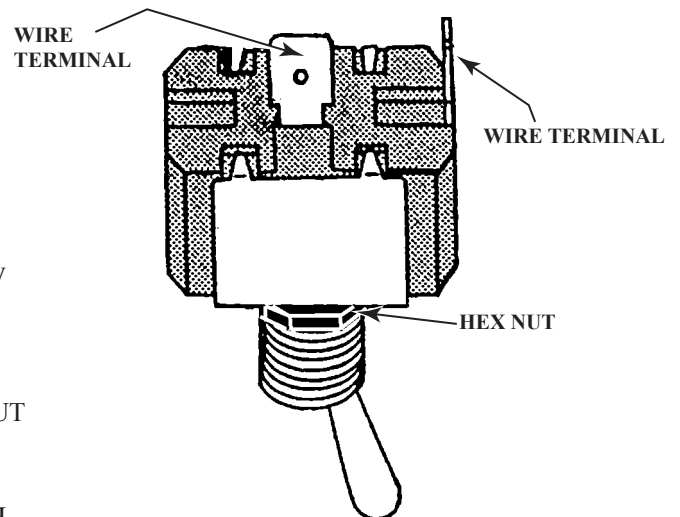

**TOGGLE ON/OFF SWITCH
CARLING NO. 2FA53-73
PN 18-204**

CAUTION: EXERCISE CARE NOT TO DAMAGE THE RED ELECTRICAL WIRES CONNECTED TO THE SWITCH TERMINALS.

5. CAREFULLY remove the RED wire connected to the END wire terminal of the defective switch and SECURELY connect it to the IDENTICAL wire terminal of the NEW switch. Repeat this step to remove and connect the other RED wire to the SIDE wire terminal of the new switch.
6. CAREFULLY insert the new toggle ON/OFF switch in the SWITCH COMPARTMENT opening install the switch lever into the switch mounting plate, secure the switch to the plate using the 7/16" (11 mm) HEX NUT; then replace the GRAY Protective Rubber Boot on the Switch .

7. Remove any DRY silicone around the perimeter of the switch compartment and cover, replace and secure the switch compartment cover using screws removed in step 2; then place a SMALL bead of silicone around the perimeter of the switch compartment cover.
8. Replace the Batter/Sifter Cart electrical plug in the electrical receptacle, test operate the Batter/Sifter Cart; then replace the Sifter Basket Assembly and Flour Pan.

D. RED POWER INDICATOR LAMP - A RED 120 volt, $\frac{1}{3}$ watt Snap light is used to provide a visual indication that electric power to the Batter/Sifter Cart is ON when it is illuminated. If this snaplight fails it should be replaced with an identical snaplight.

To replace a Red Burner Indicator Lamp:

1. Repeat Steps 1 and 2 paragraph C above.
2. CAREFULLY remove the defective lamp from the switch mounting plate by depressing the SPRING CLIPS shown in the diagram on the right; then apply pressure to the BOTTOM of the lamp.
3. CAREFULLY separate the BLACK and WHITE wires connected to the two (2) BLACK lamp electrical wires; then discard the defective lamp.

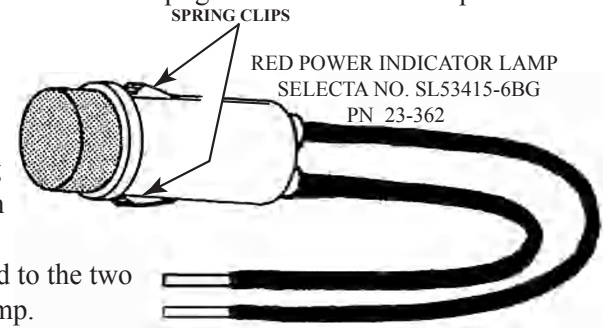

CAUTION: EXERCISE CARE SO NOT TO DAMAGE THE BLACK AND WHITE WIRES CONNECTED TO THE BLACK WIRES.

4. SECURELY connect the BLACK wire (separated from the lamp wire in step 3) to one of the new lamp's BLACK wires; then SECURELY connect the WHITE wire to the remaining BLACK wire of the new lamp.
5. CAREFULLY feed the lamp electrical wires through the lamp hole in the switch mounting plate; then insert the new lamp into the mounting plate hole and apply pressure to SEAT the lamp in the hole.

NOTE: It may be necessary to depress the SPRING CLIPS to properly seat the lamp in the hole.

6. Repeat steps 7 and 8 paragraph C above.

E. FLOUR BIN INTERLOCK SWITCH - The flour bin interlock switch PN 18-099 is located on the rear panel of the Batter/Sifter Cart and its purpose is to OPEN the electrical circuit to the sifter motor whenever the flour bin drawer is opened. In order to replace the electrical switch the REAR panel of the Batter/Sifter Cart must be removed.

1. To replace a flour bin interlock switch:

- a. Remove the Batter/Sifter Cart electrical plug from the electrical receptacle, remove the flour bin assembly; then remove the rear panel from the cart.
- b. Remove the MICROSWITCH from the ACTUATOR by removing the two (2) 6-32 x 1" (25 mm) round head screws, nuts and lock washer; then remove the two (2) RED electrical wires from the microswitch.
- c. Discard the defective microswitch; install the new switch on the actuator so the RED BUTTON on the switch is aligned with the PLUNGER of the actuator; then secure the switch to the actuator using the two (2) 6-32 x 1" (25 mm) screws, nuts and lock washers removed in step 1 a above.
- d. Install one (1) RED electrical wire on the CENTER terminal of the switch and install the remaining RED wire on the COMMON terminal.
- e. Replace and secure the rear panel on the cart; then connect the Batter/Sifter Cart electrical plug to the electrical receptacle and test operate the cart.

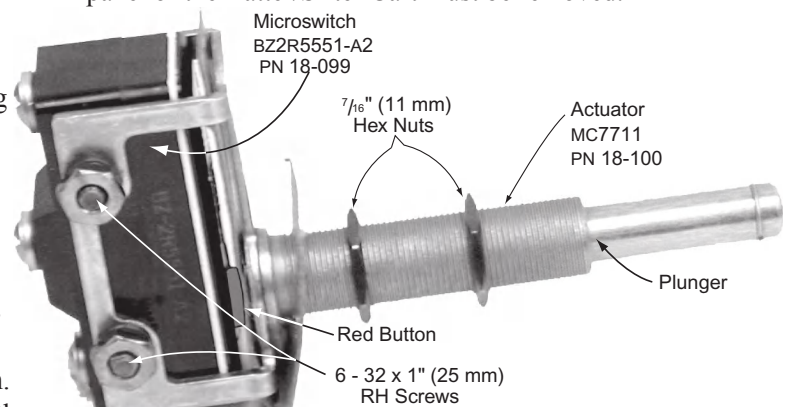

2. To replace the interlock switch actuator:
 - a. Remove the Batter/Sifter Cart electrical plug from the electrical receptacle, remove the flour bin drawer assembly from the Batter/Sifter Cart; then remove the rear panel of the cart.
 - b. Remove the MICROSWITCH from the ACTUATOR by removing the two (2) 6-32 x 1" (25 mm) round head screws, nuts and lock washers.
 - c. Remove the actuator from the Batter/Sifter Cart by removing the $\frac{7}{16}$ "(11 mm) hex nut from the PLUNGER end of the actuator.
 - d. Remove one (1) $\frac{7}{16}$ "(11 mm) hex nut from the new actuator; place the remaining $\frac{7}{16}$ "(11 mm) hex nut on the new actuator in the same position as the $\frac{7}{16}$ "(11 mm) hex nut on the defective actuator; and secure the new actuator to the Batter/Sifter Cart using a $\frac{7}{16}$ "(11 mm) hex nut.
 - e. Install the microswitch on the actuator following procedures in steps 1c and 1d on the previous page.
 - f. Replace the flour bin drawer assembly; connect the Batter/Sifter Cart electrical plug to the electrical receptacle; and test operate the Batter/Sifter Cart to insure the inter-lock switch turns the sifter motor OFF when the flour bin drawer is OPEN. If necessary, readjust location of the ACTUATOR by relocating the two (2) $\frac{7}{16}$ "(11 mm) hex nuts.
 - g. Replace and secure the rear panel on the Batter/Sifter Cart.

MECHANICAL COMPONENTS

The Batter/Sifter Cart mechanical components consist of the Sifter Motor, V-Belt, two (2) Pulleys, Sifter Mechanism Shaft, two (2) Pillow Blocks, Sifter Activator Bar and Cam, and Shaft Seal. To gain access to the Sifter Mechanism Compartment 1) remove the REAR panel from the Batter/Sifter Cart and 2) remove the PULLEY SHIELD by loosening the two (2) $\frac{3}{8}$ " (10 mm) nylon hex nuts on the weld studs.

CAUTION: PRIOR TO REPLACING A MECHANICAL COMPONENT REMOVE THE BATTER/SIFTER CART ELECTRICAL PLUG FROM THE ELECTRICAL RECEPTACLE.

- A. SIFTER MOTOR V-BELT - A Type 4L340 V-Belt is used to drive the Sifter Mechanism Shaft. If the V-Belt becomes worn it should be replaced by an identical V-Belt.

To replace the Sifter Motor V-Belt:

1. Use thumb pressure to slip the defective V-Belt off of the SMALL Motor Pulley; then remove it from the LARGE sifter shaft pulley.
2. Place the new V-Belt on the LARGE sifter shaft pulley; then slip it on the SMALL motor pulley using thumb pressure.

- B. SIFTER MOTOR - A Dayton Model 5K260C $\frac{1}{4}$ HP, 1725 RPM, 120 Volt, single phase commercial duty motor is used to operate the Batter/Sifter Cart sifter mechanism. If the motor becomes defective, replace it with an identical motor.



MOTOR BATTER/SIFTER CART
DAYTON MODEL 5K260C
PN 17-047

To replace the Sifter Motor:

1. Perform step A 1 above.
2. Remove the BLACK, GREEN and WHITE Sifter Motor electrical wires from the Batter/Sifter Cart electrical cord by removing the three (3) wire nuts.
3. CAREFULLY remove the defective motor from the interior bulkhead by removing the four (4) $\frac{5}{16}$ " (8 mm) nylon hex nuts from the bolts welded to the bulkhead.
4. Remove the 1 $\frac{3}{4}$ " (45 mm) Sifter Motor Pulley and key from the motor shaft by loosening the $\frac{5}{32}$ " (4 mm) Allen set screw.
5. Remove the electrical terminal cover of the motor and remove the BLACK, GREEN and WHITE wires of the motor electrical cord from the terminals.



SIFTER MOTOR V-BELT
TYPE 4L340
PN 25-033

- Remove the electrical terminal cover of the NEW sifter motor and relocate the BLACK and RED internal electrical wires as follows:

<u>WIRE COLOR</u>	<u>FROM TERMINAL</u>	<u>TO TERMINAL</u>
BLACK	5	2
RED	2	5

NOTE: The Dayton Model 5K260C is factory wired for a CLOCKWISE (CW) rotation and it MUST be re-wired to rotate COUNTER-CLOCKWISE (CCW) for proper operation of the sifter mechanism.

- Connect the sifter motor electrical cord wires as shown below: then replace and secure the electrical terminal cover:

<u>WIRE COLOR</u>	<u>CONNECT TO TERMINAL</u>
BLACK	1 (COPPER TERMINAL)
GREEN	(GREEN HEX HEAD CASE SCREW)
WHITE	4 (SILVER TERMINAL)

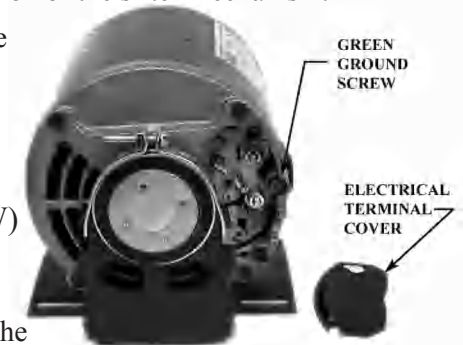

- Place the motor on a flat surface, turn the motor shaft until the keyway on the shaft is pointing UPWARD; then insert the KEY removed in step 4 above in the keyway of the motor shaft.
- Align the keyway on the 1 3/4" (45 mm) Sifter Motor Pulley with the key on the motor shaft and CAREFULLY slip the pulley over the motor shaft.
- TEMPORARILY tighten the 5/32" (4 mm) Allen set screw on the pulley, install the sifter motor on the four (4) bolts welded to the bulkhead; then secure the motor to the bulkhead with the four (4) 5/16" (8 mm) nylon hex nuts removed in step 3 above.
- Using a straight edge ENSURE the sifter motor pulley is aligned with the LARGER 8" (203 mm) sifter mechanism shaft pulley. If necessary, align the pulleys as follows:
 - Loosen the 5/32" (4 mm) Allen set screw on the sifter motor pulley.
 - Position the sifter motor pulley where it is aligned with the sifter mechanism shaft pulley.
 - Securely tighten the 5/32" (4 mm) Allen set screw on the sifter motor pulley.

CAUTION: IF PULLEYS ARE NOT ALIGNED THERE WILL BE EXCESSIVE WEAR ON THE SIFTER MOTOR AND PILLOW BLOCK BEARINGS CAUSING PREMATURE FAILURES.

- Place the V-Belt on the LARGE 8" (203 mm) Sifter Shaft Pulley; then slip it on the 3/4" (45 mm) Sifter Motor Pulley using thumb pressure.
- Connect the BLACK, GREEN and WHITE wires of the sifter motor electrical cord to the Batter/Sifter Cart electrical cord BLACK, GREEN and WHITE wires and secure these connections using the wire nuts removed in step 2 above.

- SIFTER MOTOR PULLEY - A 1 3/4" (45 mm) diameter Browning No. 3X759 pulley is used on the sifter motor. If it becomes defective it MUST be replaced with an identical pulley.

To replace the sifter motor pulley:

- Perform steps A 1, B 2, B 3, and B 4 (page 17) IN THAT ORDER.
- Perform steps B 8, B 9, B 10, B 11, B 12, and B 13 (above) IN THAT ORDER.



SIFTER MOTOR PULLEY
BROWNING NO. 3X759
PN 25-032

- SIFTER ACTIVATOR BAR CAM - A Counter Weight Cam with a Activator Bar bushing is used to rotate the Sifter Basket Assembly at the proper speed. If it becomes defective it MUST be replaced with an identical item.

To replace a Sifter Activator Bar Cam:

1. Remove the Flour Pan, Doughball Separator and Sifter Basket Assembly from the Batter/Sifter Cart following procedures in paragraph III A, Part One of this manual.
2. CAREFULLY grasp the LARGE 8" (203 mm) Sifter Shaft Pulley with one hand to hold it STATIONARY, grasp the sifter activator bar with the other hand and SLOWLY rotate the sifter activator bar in a COUNTER-CLOCKWISE (CCW) DIRECTION until the Cam separates from sifter shaft.
3. Remove the defective Sifter Activator Bar Cam from the Sifter Activator Bar by removing the 1/2" (13 mm) hex head bolt, 2 spacers and 1/2" (13 mm) hex nut.
4. Install the new Sifter Activator Bar Cam on the existing Sifter Activator Bar and secure it to the bar using the 1/2" (13 mm) hex head bolt, 2 spacers and 1/2" (13 mm) hex nut.
5. CAREFULLY position the sifter activator bar cam DIRECTLY above the sifter shaft and SLOWLY turn it in a CLOCKWISE (CW) direction to thread it onto the sifter shaft. GRASP THE LARGE 8" (203 mm) Sifter Shaft Pulley with one hand and SLOWLY rotate the sifter activator bar with the other hand in a CLOCKWISE (CW) direction to tighten the cam on the shaft.
6. Replace the Sifter Basket Assembly, Doughball Separator, and Flour Pan in the Batter/Sifter Cart following procedures in Paragraph A Part One of this manual.



SIFTER ACTIVATOR BAR CAM
REECE MANUFACTURING NO. RMI-P05
PN 25-035

- E. SIFTER ACTIVATOR BAR - A Sifter Activator Bar is connected between the sifter activator bar cam and sifter basket assembly to rotate the basket. If it becomes damaged it must be replaced with an identical item.

To replace a Sifter Activator Bar:

1. Perform steps D 1, D 2, and D 3 IN THAT ORDER.
2. Install the new Sifter Activator Bar on the existing Sifter Activator Bar Cam and secure it with the 1/2" (13 mm) hex head bolt, 2 spacers and 1/2" (13 mm) hex nut removed in step D 3 above.
3. Perform steps D 5 and D 6,

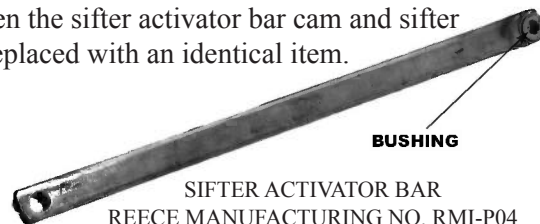

SIFTER ACTIVATOR BAR
REECE MANUFACTURING NO. RMI-P04
PN 25-036

- F. SIFTER MECHANISM SHAFT - A Sifter Mechanism Shaft and 8" (203 mm) diameter pulley is mounted to the interior compartment of the Batter/Sifter Cart and is used to rotate the Sifter Basket at the proper speed. If it becomes defective it must be replaced with an identical item.

To replace a Sifter Mechanism Shaft:

1. Perform steps A 1, D 1 and D 2.
2. Remove the Sifter Mechanism Shaft and Pulley from the interior compartment of the Batter Sifter Cart as follows:
 - a. Remove the SHAFT SEAL located above the TOP PANEL of the interior sifter mechanism compartment.
 - b. Remove the LOWER Pillow Block by removing the two (2) 3/8" (10 mm) nylon hex nuts from the weld studs on the panel.
 - c. While holding the Sifter Mechanism Shaft in one hand, remove the UPPER Pillow Block by removing the two (2) 3/8" (10 mm) nylon hex nuts from the weld studs.
3. Remove the 8" (203 mm) diameter Pulley from the Sifter Mechanism Shaft by loosening the 5/32" (4 mm) Allen Set screw.
4. Mark location of the two (2) Pillow Blocks on the defective Sifter Mechanism Shaft; then remove both Pillow Blocks by loosening the 7/64" (3 mm) Allen set screw on each Pillow Block.
5. Place the new Sifter Mechanism Shaft along side of the defective shaft and mark location of the two (2) Pillow Blocks on the new shaft.
6. Install the two (2) Pillow Blocks on the new Sifter Mechanism Shaft where marked, and secure each pillow block to the shaft by tightening the 7/64" (3 mm) Allen set screw on each block.

SIFTER MECHANISM SHAFT
REECE MANUFACTURING NO. RMI-P28
PN 25-037

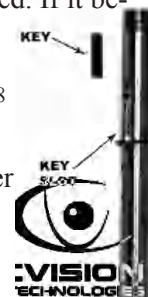

7. Remove the KEY from the Keyway on the Sifter Mechanism Shaft, place the shaft on a flat surface until the keyway on the shaft is pointing UPWARD; then replace the KEY in the keyway.
8. Align the keyway on the pulley with the key on the shaft, CAREFULLY slip the pulley over the shaft until the key is seated in the pulley keyway, then secure the pulley to the shaft by tightening the $\frac{5}{32}$ " (4 mm) Allen set screw.
9. Install the Sifter Mechanism Shaft in the interior compartment of the Batter/ Sifter Cart as follows:
 - a. Secure the UPPER Pillow block to the upper two (2) weld studs using the $\frac{3}{8}$ " (10 mm) nylon hex nuts removed in step 2 c above.
 - b. Secure the LOWER Pillow Block to the lower two (2) weld studs using the $\frac{3}{8}$ " (10 mm) nylon hex nuts removed in step 2 b above.
10. Perform steps A 2, D 5 and D 6 IN THAT ORDER.

G. SIFTER MECHANISM SHAFT PULLEY - A 8" (203 mm) diameter Pulley is attached to the Sifter Mechanism Shaft to reduce the Sifter Motor speed of 1725 RPM to 430 RPM for proper operation of the Sifter Basket. If this pulley becomes defective it must be replaced with an identical pulley.

To replace the Sifter Mechanism Shaft Pulley:

1. Perform steps A 1, D 1, D 2, F 2, and F 3 IN THAT ORDER.
2. Perform steps F 7, F 8, F 9, D 5, D 6 and A 2 IN THAT ORDER.



SIFTER MECHANISM SHAFT PULLEY
BROWNING NO. 3X796
PN 25-031

H. PILLOW BLOCK - Two (2) Pillow Blocks are used to mount the Sifter Mechanism Shaft to the interior compartment of the Batter/Sifter Cart. If either Pillow Block becomes defective it must be replaced with an identical item.

To replace a Pillow Block:

1. Perform steps A 1, D 1, D 2 and F 2 IN THAT ORDER.
2. Mark location of the defective Pillow Block on the Sifter Mechanism Shaft; then remove the defective Pillow Block by loosening the $\frac{7}{64}$ " (3 mm) Allen set screw.
3. Install the new Pillow Block on the Sifter Mechanism Shaft where marked and secure it by tightening the $\frac{7}{64}$ " (3 mm) Allen set screw.
4. Perform steps F 9, D 5, D 6 and A 2 IN THAT ORDER.



PILLOW BLOCK NO. UCP202-10
PN 25-030

I. RUBBER SHAFT SEAL - A rubber shaft seal is mounted on the Sifter Mechanism Shaft where it protrudes above the top panel of the SEALED sifter mechanism compartment to ensure sifted flour cannot seep into this compartment. If it becomes deteriorated it should be replaced with an equivalent seal.

To replace a Rubber Shaft Seal:

1. Perform steps D 1 and D 2 IN THAT ORDER.
2. Remove the defective Rubber Shaft Seal from the sifter shaft, THOROUGHLY clean the sifter shaft protruding through the top panel of the sealed Sifter Mechanism Compartment; then install the new Rubber Shaft Seal on the sifter shaft.
3. Perform steps D 5 and D 6 IN THAT ORDER.



RUBBER SHAFT SEAL
REECE MANUFACTURING NO. RML-P02
PN 25-038

- J. BATTER / SIFTER CART CASTERS - The Batter/Sifter Cart is equipped with four(4) Payson type 050-40X swivel casters. This caster has two precise ball bearing race ways protected from moisture by neoprene molds, and 4" (102 mm) high Payflex soft tread wheels. The top plate of each caster is mounted on 1/4-20 weld studs attached to a hat section on the base of the Batter/Sifter Cart.

To replace a swivel caster:

1. Disconnect the Batter/Sifter Cart electrical plug from the electrical receptacle; relocate the cart to an area where it can be laid on the floor; remove the flour bin, flour pan, batter pan and sifter basket assembly; then CAREFULLY lay the BACK of the Batter Table on the floor.
2. Remove the defective caster by removing the four (4) 1/4-20 nylon lock nuts with a $\frac{7}{16}$ " (11 mm) open end or box end wrench; and secure the new caster to the cart using these nuts and wrench.

NOTE: Sometimes the table will ROCK when only one caster is replaced due to wear of the adjacent caster. If this problem occurs, replace the adjacent front/back caster.

3. Place the cart in an UPRIGHT position; replace items removed in Step 1 above; and connect the electrical plug to the electrical receptacle.



PAYSON TYPE 050-40X CASTER
PN 28-006

PARTS LIST & SUPPLY

TECHNICAL ASSISTANCE - Contact an authorized service agent or the Customer Service Department, Ultrafryer Systems at 1-800-525-8130 for technical assistance.

ORDERING INFORMATION:

1. REPLACEMENT PARTS - Provide the following information when ordering replacement parts by phone, fax or mail:

Your company name and phone number
Your company purchase order number
Bill-to address
Ship-to address
Quantity desired
Part number and description of the desired-item
Your name or signature of authorized-buyer
Phone in order to: 1-800-545-9189 Ext 5029
FAX order to: 1-210-731-5099
Mail order to: Ultrafryer Systems
Order Entry Office
P.O. Box 5369
San Antonio, TX 78201
E-Mail your order to: Ultrafryerservice@afce.com

2. TERMS - Net 30 days for customers on open accounts. Past due balances will be charged 1 1/2% per month (I 8% per annum) until full balance is paid.
3. DAMAGES - Ultrafryer Systems is not responsible for damage occurring in transit. All deliveries must be inspected for damage to shipping containers prior to departure of the delivering carrier. Any damage must be notated on the receiving document to facilitate filing of freight claims. Carriers must be notified immediately and freight inspections must be requested from the carrier. Ultrafryer Systems can and will gladly assist you in preparing and processing of the necessary claims only if proper notification has been accomplished on the carrier delivery document. Damaged equipment and or containers must be available for the claims inspector to inspect.
4. RETURNS - Ultrafryer Systems cannot guarantee credit for items returned without proper authorization. All returns must have prior Ultrafryer Systems Customer Service or Warranty department approval. An assigned number will be issued by the approval authority. Please print the assigned number on all returned packages and corresponding paperwork. Returned goods are subject to a 15% restocking charge. Ultrafryer Systems is not responsible for freight charges on returned goods unless authorized by Customer Service and or Warranty personnel. Ultrafryer Systems does not receive freight collect or C.O.D. shipments.

PARTS IDENTIFICATION - Locate the part on the following sketches and note the index number i.e, 1, 2, etc; then obtain the part number and description for that index number on the page facing the sketches. Use that part number when ordering a replacement part.

PARTS LIST AND SUPPLY

Items listed in paragraphs I and II may be ordered through normal supply channels or by calling 1-800-545-9189.

I. BATTER/SIFTER CART COMPONENTS

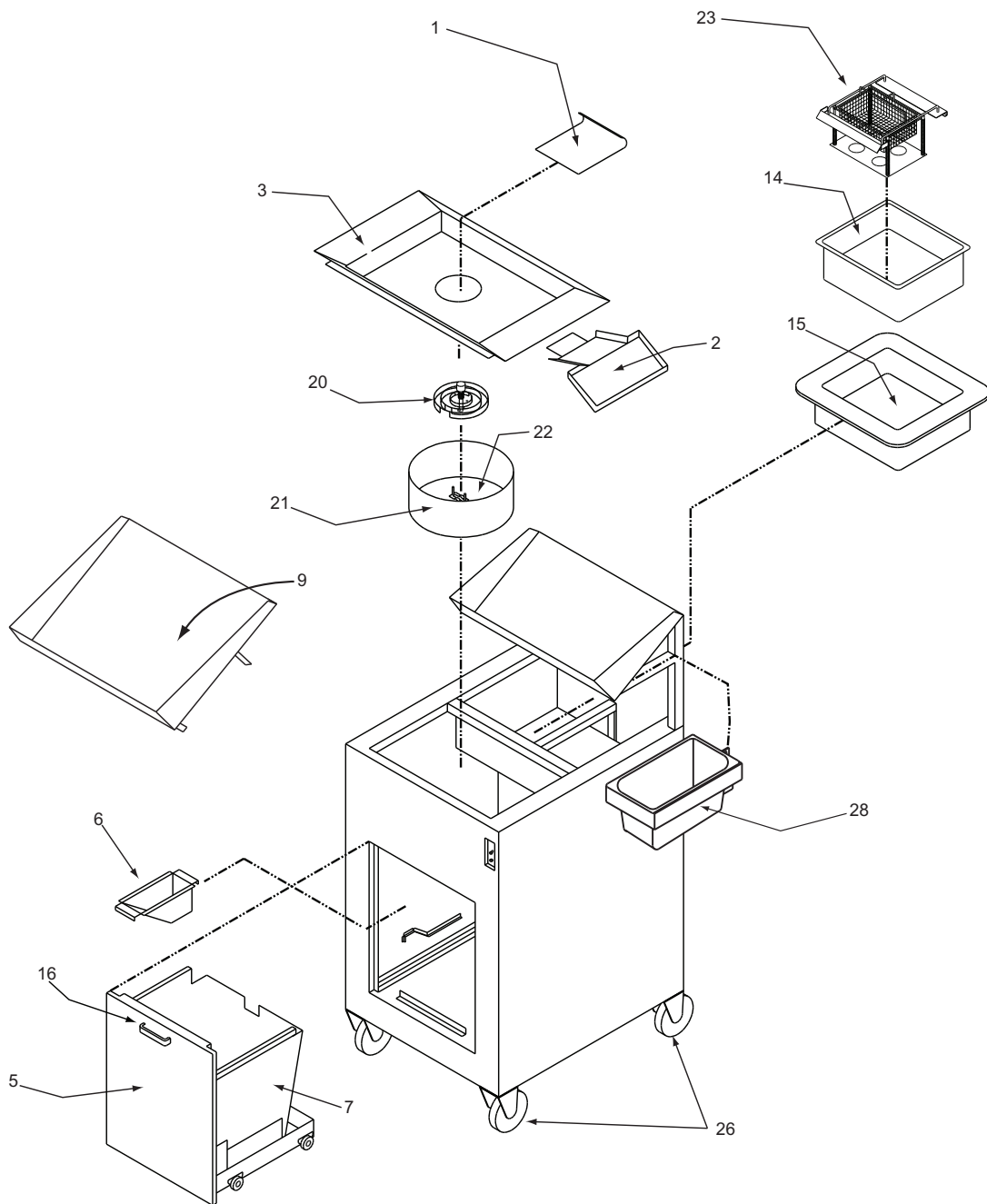

BATTER / SIFTER CART COMPONENT LOCATIONS		
ITEM	DESCRIPTION	PN
1	Flour Pan Scraper & Cover	12-015
2	Batter/Sifter Cart Extension (Optional Purchase)	12-075
3	Flour Pan	12-106
*4	Flour Bin Latch	12-121
5	Flour Bin Assembly w/o Liner	12-291
6	Dough Ball Catch Pan	12-695
7	Plastic Flour Bin Liner	12-704
*8	Flour Flow Cover	12-705
9	Top Pan Accessory Shelf (Optional Purchase)	12-708
*10	Flour Bin Interlock Switch	18-099
*11	Flour Bin Interlock Switch & Actuator	18-100
12	3 Size S/S Pan (Optional Purchase)	21-101
*13	9 Size S/S Hand Wash Pan (Optional Purchase)	21-418
14	q Size S/S Hand "Batter" Pan (NOTE 1 & 2)	21-442
15	Cold Batter Pan (NOTE 1)	21-632
16	Flour Bin Drawer Chrome Pull	22-005
*17	Slide Mount Shelve Roller	22-006
*18	Magnetic Door Catch	22-407
*19	Sifter Basket Bushing #RMI-P35	22-738
20	Doughball Separator Assembly #RM1-011	22-739
21	Sifter Basket w/Screen #RM1-016	22-740
22	Sifter Basket Screen #RM1-022	22-742
23	Dip-N-Flip Basket (NOTE 1)	22-766
*24	Type SJO 18/3 Electrical Spring Cord	23-158
*25	Hubbell Type HBL 4720C Twist Lock Electrical Plug	23-184
26	Payson Type 050-40X 4" Swivel Caster	28-006

*** NOT SHOWN**

- NOTE:** 1) This Item is **ONLY** available when purchased separately under PN [12A080](#), Batter Cart & Cold Pan Kit.
2) For q Size S/S Batter Pan w/Fluid Level marks order PN 21-100.

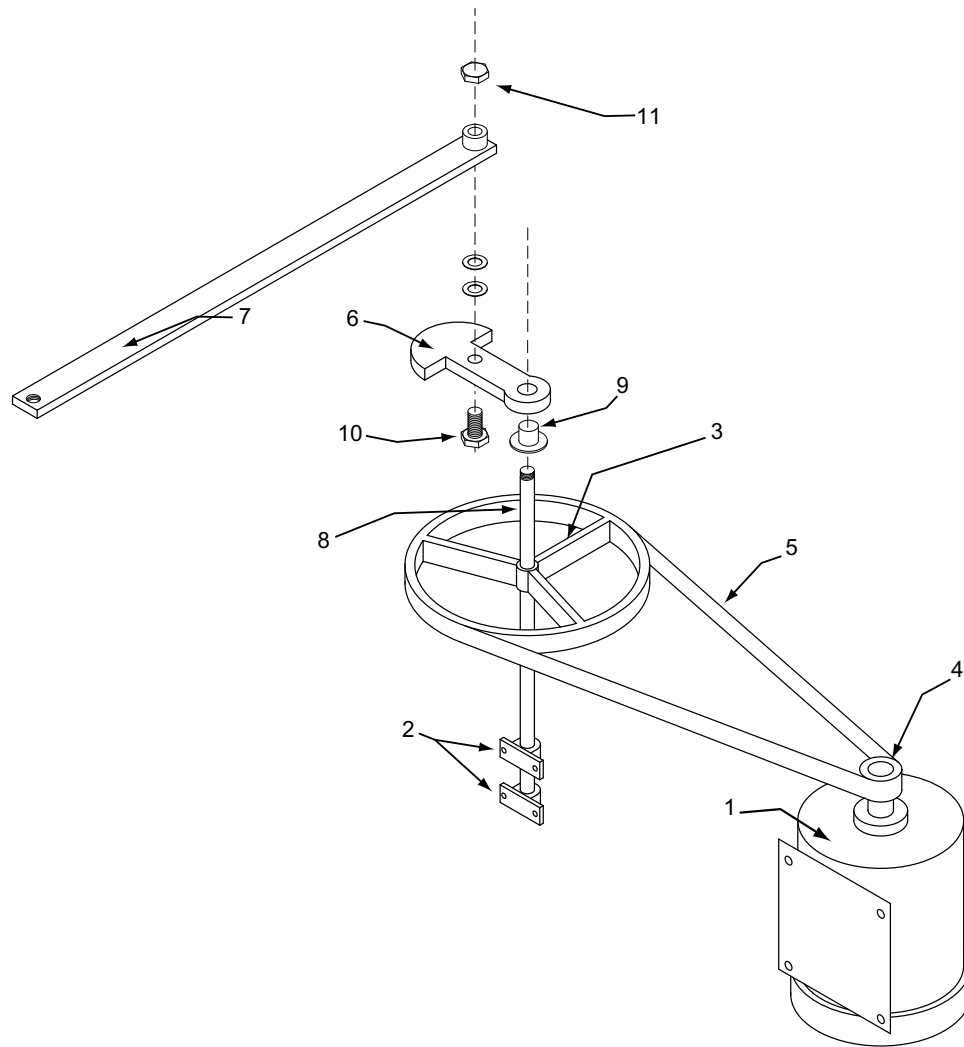

SIFTER MECHANISM ASSEMBLY COMPONENTS		
ITEM	DESCRIPTION	PN
1	115 Volt 1 Ø 60 Hz ¼ HP 1725 RPM Dayton No. SK260C Sifter Motor	17-047
2	Pillow Block No. UCP202-10	25.030
3	Large 8" (203mm) Diameter Pulley No. 3X796	25-031
4	Small 1¼" (45mm) Diameter Pulley 3X759	25-032
5	Type No. 4L340 "V" Belt	25-033
6	Sifter Actuator Bar Cam No. RM1=P01	25-035
7	Sifter Actuator Bar No. RM1-P03	25-036
8	Sifter Mechanism Shaft w/Truarc Ring No. RM1-P27	25-037
9	Rubber Shaft Seal No. RM1-P02	25-038
10	S/S Hex Head 12mm Dia x 30mm Lg Bolt	27-261
11	S/S Hex Head 12mm Nut	27-262

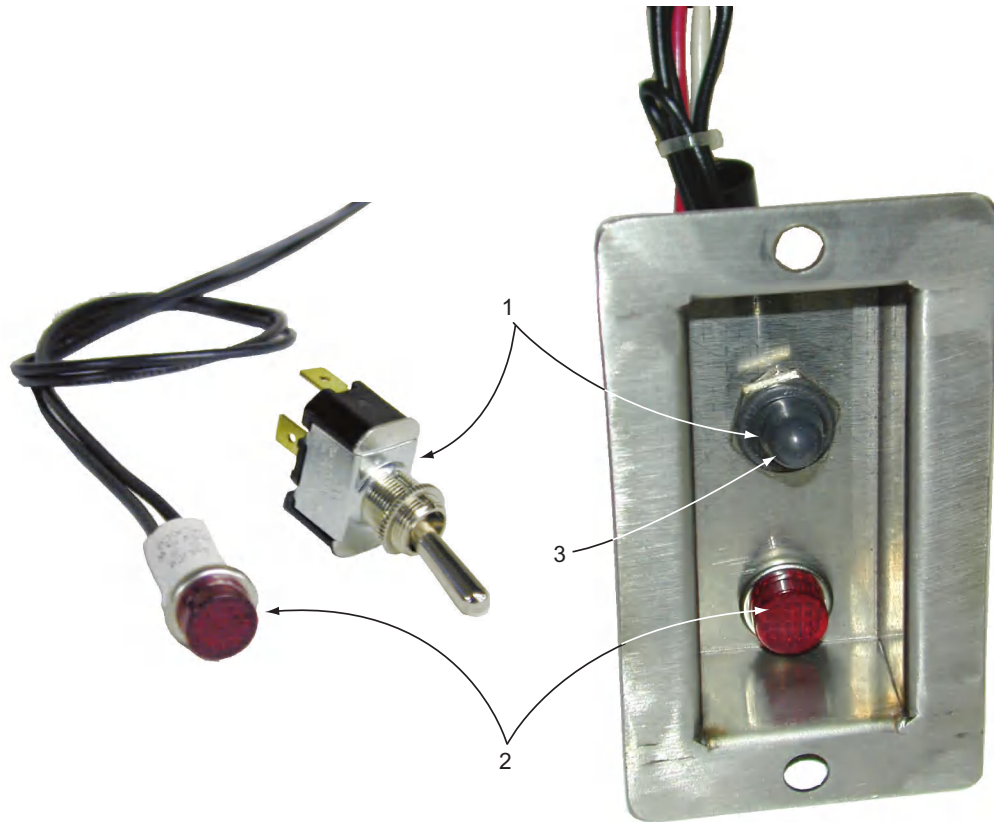

TOGGLE ON/OFF SWITCH ASSEMBLY		
<u>ITEM</u>	<u>DESCRIPTION</u>	<u>PN</u>
1	125/250 Volt 5/10 Ampere SPST Toggle ON/OFF Switch	18-204
2	125 Volt 3 Watt Snaplight w/ RED Lens	23-362
3	Toggle ON/OFF Switch Protective Rubber Boot	23-402
*4	10 - 24 x ½" (13mm) S/S Truss Head Screw	27-020