

**CLASSIC 123**



---

EN

# Service Manual



\*Original instructions

RB9912- 2020.05

## Foreword



The installation, use and maintenance manual (hereinafter Manual) provides the user with information necessary for correct and safe use of the machine (or “appliance”).

The following must not be considered a long and exacting list of warnings, but rather a set of instructions suitable for improving machine performance in every respect and, above all, preventing injury to persons and animals and damage to property due to improper operating procedures.

All persons involved in machine transport, installation, commissioning, use and maintenance, repair and disassembly must consult and carefully read this manual before carrying out the various operations, in order to avoid wrong and improper actions that could compromise the machine's integrity or endanger people. Make sure to periodically inform the user regarding the safety regulations. It is also important to instruct and update personnel authorised to operate on the machine, regarding its use and maintenance.

The manual must be available to operators and carefully kept in the place where the machine is used, so that it is always at hand for consultation in case of doubts or whenever required.

If, after reading this manual, there are still doubts regarding machine use, do not hesitate to contact the Manufacturer or the authorised Service Centre to receive prompt and precise assistance for better operation and maximum efficiency of the machine. During all stages of machine use, always respect the current regulations on safety, work hygiene and environmental protection. It is the user's responsibility to make sure the machine is started and operated only in optimum conditions of safety for people, animals and property.



### **IMPORTANT**

- The manufacturer declines any liability for operations carried out on the appliance without respecting the instructions given in this manual.
- The manufacturer reserves the right to modify the appliances presented in this publication without notice.
- No part of this manual may be reproduced.
- This manual is available in digital format by:
  - contacting the dealer or reference customer care;
  - downloading the latest and up to date manual on the web site;
- The manual must always be kept in an easily accessed place near the machine. Machine operators and maintenance personnel must be able to easily find and consult it at any time.

# Contents

A	SAFETY INFORMATION .....	5
A.1	General information .....	5
A.2	General safety .....	5
A.3	Personal protection equipment .....	6
A.4	Transport, handling and storage .....	6
A.5	Installation and assembly .....	7
A.6	Water connection .....	7
A.7	Electrical connection .....	7
A.8	Use .....	8
A.9	appliance cleaning and maintenance .....	8
A.10	Service .....	8
A.11	Disposal of packing .....	8
A.12	Machine disposal .....	9
B	WARRANTY .....	9
B.1	Warranty terms and exclusions .....	9
C	GENERAL SAFETY RULES .....	9
C.1	Introduction .....	9
C.2	Mechanical safety characteristics, hazards .....	9
C.3	Protection devices installed on the machine .....	9
C.4	Main switch .....	9
C.5	Safety signs to be placed on the machine or near its area .....	10
C.6	Instructions for use and maintenance .....	10
C.7	Reasonably foreseeable improper use .....	10
C.8	End of use .....	10
C.9	Residual risks .....	10
D	GENERAL INFORMATION .....	11
D.1	Introduction .....	11
D.2	Definitions .....	11
D.3	Machine and manufacturer's identification data .....	11
D.4	Additional indications .....	12
D.5	Responsibility .....	12
D.6	Copyright .....	12
D.7	Keeping the manual .....	12
D.8	Recipients of the manual .....	12
E	NORMAL USE .....	12
E.1	Characteristics of personnel enabled to operate on the machine .....	12
E.2	Characteristics of personnel trained for normal machine use .....	12
E.3	Operator qualified for normal machine use .....	12
F	TECHNICAL CHARACTERISTICS .....	13
F.1	Data table .....	13
G	INSTALLATION & ASSEMBLY .....	13
G.1	Preparing the appliance .....	13
G.1.1	Fitting high feet (optional) .....	13
G.2	Water connection .....	13
G.2.1	Water supply .....	13
G.2.2	Draining .....	14
G.3	Electrical connection .....	15
G.3.1	Connection diagrams .....	15
G.4	Checks & adjustments .....	15
G.4.1	Temperature adjustment .....	15
G.4.2	Adjusting the expansion valve .....	16
G.4.3	Adjusting the pump pressure .....	16
G.4.4	Adjusting the coffee grinding .....	16
G.4.5	Softener .....	16
H	OPERATING .....	16
H.1	Switching on .....	16
H.2	Keyboards .....	17
H.2.1	Electronic coffee box .....	17
H.3	Programming .....	17
H.3.1	Pc = Calculated programming .....	17
H.3.2	Pn = Digital programming .....	17
H.3.3	Pr = Manual programming .....	17
H.4	Configuration of different keyboards .....	17
H.4.1	2-cup units (type d2) .....	17
H.5	How to prepare a cappuccino .....	18
I	CLEANING .....	18
I.1	Coffee cleaning .....	18
I.1.1	Rinsing of decompression circuit .....	18
I.1.2	Weekly cleaning with detergent pellet .....	18
I.2	External cleaning .....	18

J	MAINTENANCE .....	19
J.1	Preventive maintenance.....	19
K	TROUBLESHOOTING .....	20
K.1	Faults reported by the electronic display .....	20
K.1.1	Problems related to the electronic box control keys.....	20
K.1.2	Problems of fuses .....	20
K.1.3	Dosing problems .....	20
K.1.4	Other faults .....	22
K.1.5	Level adjustment problems.....	23
K.1.6	Unable to programme .....	24
K.1.7	The “heating doesn't follow.....	24
L	RELATED DOCUMENTS .....	25
L.1	Wiring diagrams .....	25

---

## A SAFETY INFORMATION

---

### A.1 General information

To ensure safe use of the appliance and a proper understanding of the manual it is necessary to be familiar with the terms and typographical conventions used in the documentation. The following symbols are used in the manual to indicate and identify the various types of hazards:



#### **WARNING**

Danger for the health and safety of operators.



#### **WARNING**

Danger of electrocution - dangerous voltage.



#### **CAUTION**

Risk of damage to the machine or the product.



#### **IMPORTANT**

Important instructions or information on the product



Read the instructions before using the appliance







Clarifications and explanations

### A.2 General safety

- The machine must not be used by people (including children) with limited physical, sensory or mental abilities or without experience and knowledge of it, unless instructed in its use and supervised by those responsible for their safety.
  - Do not let children play with the machine.
  - Keep all packaging and detergents away from children.
  - Cleaning and user maintenance shall not be made by children without supervision.
- For suitable personal protection equipment, refer to chapter “A.3 *Personal protection equipment*”.
- Several illustrations in the manual show the machine, or parts of it, without guards or with guards removed. This is purely for explanatory purposes. Do not install the machine without the guards or with the protection devices deactivated.
- Do not remove, tamper with or make illegible the safety, danger and instruction signs and labels on the machine.
- Do not remove or tamper with the machine’s safety devices.
- Before carrying out any machine installation, always consult the installation manual, which gives the correct procedures and contains important information on safety.
- Unauthorized personnel must not enter the work area.
- Remove any flammable products or items from the work area.
- Machine positioning, installation and disassembly must be carried out by the specialised personnel in conformity with the current safety regulations, regarding the equipment used and the operating procedures.

## A.3 Personal protection equipment

Summary table of the Personal Protection Equipment (PPE) to be used during the various stages of the machine's service life.

Stage	Protective garments 	Safety footwear 	Gloves 	Glasses 	Safety helmet 
Transport	—	●	○	—	○
Handling	—	●	○	—	—
Unpacking	—	●	○	—	—
Installation	○	●	○ <sup>1</sup>	—	—
Normal use	—	○	—	—	—
Adjustments	—	○	○	—	—
Routine cleaning	—	—	○ <sup>2</sup>	—	—
Extraordinary cleaning	○	●	○	○	—
Maintenance	○	●	○	○	—
Dismantling	○	●	●	○	—
Scrapping	○	●	●	○	—
<b>Key:</b>					
●	<b>PPE REQUIRED</b>				
○	<b>PPE AVAILABLE OR TO BE USED IF NECESSARY</b>				
—	<b>PPE NOT REQUIRED</b>				

1. During these operations, gloves must be cut-resistant. Failure to use the personal protection equipment by operators, specialized personnel or users can involve exposure to damage to health (depending on the model).
2. During these operations, gloves must be suitable for contact with chemical substances used (refer to the safety data sheet of the substances used for information regarding the required PPE). Failure to use the personal protection equipment by operators, specialized personnel or users can involve exposure to chemical risk and cause possible damage to health (depending on the model).

## A.4 Transport, handling and storage

- Due to their size, the machines cannot be stacked on top of each other during transport, handling and storage; this eliminates any risks of loads tipping over due to stacking.
- Do not stand under suspended loads during loading or unloading operations. Unauthorized personnel must not enter the work area.
- The weight of the appliance alone is not sufficient to keep it steady.
- For machine lifting and anchoring, do not use movable or weak parts such as: casings, electrical raceways, pneumatic parts, etc.
- Do not push or pull the machine to move it, as it may tip over. Use proper tool to lift the machine.
- Machine transport, handling and storage personnel must be adequately instructed and trained regarding the use of lifting systems and personal protection equipment suitable for the type of operation carried out.

## **A.5 Installation and assembly**

- The installation must be carried out by a specialised personnel.
- Follow the installation instruction supplied with the appliance.
- Do not install a damaged appliance. Any missing or faulty parts must be replaced with original parts.
- Do not make any modifications to the parts supplied with the appliance.
- Disconnect the appliance from the power supply before carrying out any installation procedure. Connect the appliance to the power supply only at the end of the installation.
- The appliance is not suitable for installation outdoors and/or in places exposed to atmospheric agents (rain, direct sunlight, freeze, humid and dusty location, etc.).
- Make sure that the floor where you install the appliance is flat, stable, heat resistant and clean.
- Access to the service area is limited to persons with the necessary knowledge of safety and hygiene as well as practical experience of the device.
- Leave enough free space around the appliance to facilitate its use and to perform any maintenance operations.

## **A.6 Water connection**

- The plumbing connections must be carried out by a specialised personnel.
- The machine is to be connected to the water mains using the new supplied hose-sets. Do not use old hose sets.
- Always use a new set of joints if you remove and re-install the water inlet pipe to the machine.
- Before connection to new pipes, pipes not used for a long time, where repair work has been carried out or new devices fitted (water meters, etc.), let the water flow until it is clean and clear.
- The operating water pressure (minimum and maximum) must be between:
  - 1 bar [0.1 MPa] and 8 bar [0.8 MPa];
- Make sure that there are no visible water leaks during and after the first use of the machine.
- Install an approved dual check valve upstream according to the regulation of the installation country.

## **A.7 Electrical connection**

- Work on the electrical systems must only be carried out by a specialised personnel.
- Make sure that the electrical information on the rating plate agrees with the power supply.
- Make sure to install the appliance in accordance with the safety regulations and local laws of the country where used.
- If the power cable is damaged it must be replaced by the Customer Care Service or in any case by specialised personnel, in order to prevent any risk.
- The appliance must be correctly earthed. The manufacturer is not responsible for the consequences of an inadequate earthing system.
- To protect the power supply of the appliance against short circuits and/or overloads, install a thermal fuse or a suitable automatic thermal magnetic circuit breaker, ADS (Automatic Disconnection of Supply).
- To protect the power supply of the appliance against current leakages, install a high-sensitivity manual reset RCD (Residual Current Device), suitable for overvoltage category III.

For protection against indirect contacts, refer to point 6.3.3 of EN 60204-1 (IEC 60204-1) with the use of protection devices that ensure automatic cut-off of the supply in case of

isolation fault in the TN or TT systems or, for IT systems, the use of isolation controllers or differential current protection devices to activate automatic power disconnection (an isolation controller must be provided for indicating a possible first earth fault of a live part, unless a protection device is supplied for switching off the power in case of a such a fault. This device must activate an acoustic and/or visual signal which must continue for the entire duration of the fault). For example: in a TT system, a residual current device with cut-in current (e.g. 30 mA) coordinated with the earthing system of the building where the appliance is located must be installed ahead of the supply.

## **A.8 Use**

- The appliance must be used in room with an ambient temperature of 5°C to 35°C (41°F - 95°F).
- If it is stored at an ambient temperature below 5°C (41°F) the water circuit (boiler-piping) must be drained.
- In case of emergency (fire, surge, abnormal noise, etc. the first thing to do is to cut off the current and close the water tap.
- Make sure not to obstruct the air inlets of the appliance with towels or other objects.
- Beware of hot surfaces such as cup heaters, the unit heads and the hot water and steam outputs. Never install containers filled with liquid on the top of the appliance.

## **A.9 appliance cleaning and maintenance**

- Refer to “A.3 *Personal protection equipment*” for suitable personal protection equipment.
- Put the appliance in safe conditions before starting any maintenance operation. Disconnect the appliance from the power supply and carefully unplug the power supply cable, if present.
- Depending on the model and type of electric connection, during maintenance operations, the cable and plug must be kept in a visible position by the operator carrying out the work.
- Do not touch the appliance with wet hands or feet or when barefoot.
- Do not remove the safety guards.
- Respect the requirements for the various routine and extraordinary maintenance operations. Non compliance with the instructions can create risks for personnel.
- Extraordinary maintenance, checking and overhaul operations must only be carried out by a specialised personnel or the Customer Care Service, provided with suitable personal protection equipment (safety shoes and gloves), tools and ancillary means.
- Do not clean the appliance with jets of water.

## **Repair and extraordinary maintenance**

- Repair and extraordinary maintenance have to be carried out by specialised authorised personnel. The manufacturer declines any liability for any failure or damage caused by the intervention of an unauthorized technician by the Manufacturer and the original manufacturer warranty will be invalidated.
- The appliance should be descaled only by a specialised personnel.
- Do not forget to regenerate your water softener periodically.

## **A.10 Service**

- Only original spare parts can ensure the safety standards of the appliance.

## **A.11 Disposal of packing**

- Dispose of each packaging items respecting the current regulation in the country of installation.

## A.12 Machine disposal

- Work on the electrical equipment must only be carried out by a specialised personnel, with the power supply disconnected.
- Dismantling operations must be carried out by specialised personnel.
- Make the appliance unusable by removing the power cable and any compartment closing devices, to prevent the possibility of someone becoming trapped inside.
- Refer to “A.3 *Personal protection equipment*” for suitable personal protection equipment.
- When scrapping the machine, the “CE” marking, this manual and other documents concerning the appliance must be destroyed.



### IMPORTANT

Save these instructions carefully for further consultation by the various operators.

---

## B WARRANTY

### B.1 Warranty terms and exclusions

If the purchase of this product includes warranty coverage, warranty is provided in line with local regulations and subject to the product being installed and used for the purposes as designed, and as described within the appropriate equipment documentation.

Warranty will be applicable where the customer has used only genuine spare parts and has performed maintenance in accordance with Electrolux Professional user and maintenance documentation made available in paper or electronic format.

Electrolux Professional strongly recommends using Electrolux Professional approved cleaning, rinse and descaling agents to obtain optimal results and maintain product efficiency over time.

The Electrolux Professional warranty does not cover:

- service trips cost to deliver and pick up the product;
- installation;
- training on how to use/operate;
- replacement (and/or supply) of wear and tear parts unless resulting from defects in materials or workmanship reported within one (1) week from the failure;
- correction of external wiring;
- correction of unauthorized repairs as well as any damages, failures and inefficiencies caused by and/or resulting from:
  - insufficient and/or abnormal capacity of the electrical systems (current/voltage/frequency, including spikes and/or outages);
  - inadequate or interrupted water supply, steam, air, gas (including impurities and/or other that does not comply with the technical requirements for each machine);

- plumbing parts, components or consumable cleaning products that are not approved by the manufacturer;
- customer’s negligence, misuse, abuse and/or non-compliance with the use and care instructions detailed within the appropriate equipment documentation;
- improper or poor: installation, repair, maintenance (including tampering, modifications and repairs carried out by third parties not authorized) and modification of safety systems;
- Use of non-original components (e. g.: consumables, wear and tear, or spare parts);
- environment conditions provoking thermal (e. g. overheating/freezing) or chemical (e. g. corrosion/oxidation) stress;
- foreign objects placed in- or connected to- the product;
- accidents or force majeure;
- transportation and handling, including scratches, dents, chips, and/or other damage to the finish of the product, unless such damage results from defects in materials or workmanship and is reported within one (1) week of delivery unless otherwise agreed;
- product with original serial numbers that have been removed, altered or cannot be readily determined;
- replacement of light bulbs, filters or any consumable parts;
- any accessories and software not approved or specified by Electrolux Professional.

Warranty does not include scheduled maintenance activities (including the parts required for it) or the supply of cleaning agents unless specifically covered within any local agreement, subject to local terms and conditions.

Check on Electrolux Professional website the list of authorized customer care.

---

## C GENERAL SAFETY RULES

### C.1 Introduction

The machines are provided with electric and/or mechanical safety devices for protecting workers and the machine itself.

Therefore the user must not remove or tamper with such devices. The Manufacturer declines any liability for damage due to tampering or their non-use.

### C.2 Mechanical safety characteristics, hazards

The machine does not have sharp edges or protruding parts. The guards for the moving and live parts are fixed to the cabinet with screws, to prevent accidental access.

### C.3 Protection devices installed on the machine



The guards on the machine are (e.g. hopper, side panels, rear, covers, etc.) fixed to the machine and/or frame with screws that can only be removed or opened with tools;



The machine has a main switch that acts as an emergency switch.

### C.4 Main switch

In emergency case the machine can be entire deactivated by the main switch.

## C.5 Safety signs to be placed on the machine or near its area

Prohibition	Meaning
	do not oil, lubricate, repair and adjust moving parts
	do not remove the safety devices
	do not use water to extinguish fires (placed on electrical parts)

Danger	Meaning
	caution, hot surface
	danger of electrocution (shown on electrical parts with indication of voltage)

## C.6 Instructions for use and maintenance

Risks mainly of a mechanical, thermal and electrical nature exist in the machine. Where possible the risks have been neutralised:

- directly, by means of adequate design solutions.
- indirectly by using guards, protection and safety devices.

Any anomalous situations are signalled on the control panel display.

During maintenance several risks remain, as these could not be eliminated, and must be neutralised by adopting specific measures and precautions.

Do not carry out any checking, cleaning, repair or maintenance operations on moving parts. Workers must be informed of this prohibition by means of clearly visible signs.

To guarantee machine efficiency and correct operation, periodical maintenance must be carried out according to the instructions given in this manual.

Make sure to periodically check correct operation of all the safety devices and the insulation of electrical cables, which must be replaced if damaged.

## C.7 Reasonably foreseeable improper use

Improper use is any use different from that specified in this manual. During machine operation, other types of work or activities deemed improper and that in general can involve risks for the safety of operators and damage to the appliance are not allowed. Reasonably foreseeable improper use includes:

- lack of machine maintenance, cleaning and periodical checks;
- structural changes or modifications to the operating logic;
- tampering with the guards or safety devices;
- failure to use personal protection equipment by operators, specialised personnel and maintenance personnel;
- failure to use suitable accessories (e.g. use of unsuitable equipment or ladders);
- keeping combustible or flammable materials, or in any case materials not compatible with or pertinent to the work, near the machine;
- wrong machine installation;

- placing in the machine any objects or things not compatible with its use, or that can damage the machine, cause injury or pollute the environment;
- climbing on the machine;
- non-compliance with the requirements for correct machine use;
- other actions that give rise to risks not eliminable by the Manufacturer.



## WARNING

The previously described actions are prohibited!

## C.8 End of use

When the appliance is no longer to be used, make it unusable by removing the mains power supply wiring.

## C.9 Residual risks

The machine has several risks that were not completely eliminated from a design standpoint or with the installation of adequate protection devices. Nevertheless, through this manual the Manufacturer has taken steps to inform operators of such risks, carefully indicating the personal protection equipment to be used by them. In order to reduce the risks, provide for sufficient spaces while installing the unit. To preserve these conditions, the areas around the machine must always be:

- kept free of obstacles (e.g. ladders, tools, containers, boxes, etc.);
- clean and dry;
- well lit.

For the Customer's complete information, the residual risks remaining on the machine are indicated below: such situations are deemed improper and therefore strictly forbidden.

Residual risk	Description of hazardous situation
Slipping or falling	The operator can slip due to water or dirt on the floor
Burns/abrasions (e.g. heating elements, cold pan, cooling circuit plates and pipes)	The operator deliberately or unintentionally touches some components inside the machine without using protective gloves.
Stab wounds	The operator deliberately or unintentionally touches some components with sharp edges during the machine cleaning without using protective gloves.
Burns	The operator deliberately or unintentionally touches some components inside the machine or dishes at the outfeed without using gloves or without allowing them to cool.
Shearing of upper limbs	The operator violently closes the front panels.
Electrocution	Contact with live parts during maintenance operations carried out with the electrical panel powered

Residual risk	Description of hazardous situation
Crushing or injury	The specialised personnel may not correctly fix the control panel when accessing the technical compartment. The panel could close suddenly.
Chemical	Contact with chemical substances (e.g. detergent, rinse aid, scale remover, etc.) without taking adequate safety precautions. Therefore always refer to the safety cards and labels on the products used.



### IMPORTANT

In case of a significant anomaly (e.g. short circuits, wires coming out of the terminal block, motor breakdowns, worn electrical cable sheathing, etc.) the operator must immediately deactivate the machine.

## D GENERAL INFORMATION

### D.1 Introduction

Given below is some information regarding the intended use of this appliance, its testing, and a description of the symbols used (that identifies the type of warning), the definitions of terms used in the manual and useful information for the appliance user.

### D.2 Definitions

Listed below are the definitions of the main terms used in the manual. It is advisable to read them carefully before use.

Operator	machine installation, adjustment, use, maintenance, cleaning, repair and transport personnel.
Manufacturer	Electrolux Professional SpA or any other service centre authorised by Electrolux Professional SpA.
Operator for normal machine use	an operator who has been informed and trained regarding the tasks and hazards involved in normal machine use.
Customer Care service or specialised personnel	an operator instructed/trained by the Manufacturer and who, based on his professional and specific training, experience and knowledge of the accident-prevention regulations, is able to appraise the operations to be carried out on the machine and recognise and prevent any risks. His professionalism covers the mechanical, electrotechnical and electronics fields etc.
Danger	source of possible injury or harm to health.
Hazardous situation	any situation where an operator is exposed to one or more hazards.
Risk	a combination of probabilities and risks of injury or harm to health in a hazardous situation.
Protection devices	safety measures consisting of the use of specific technical means (guards and safety devices) for protecting operators against risks.
Guard	an element of a machine used in a specific way to provide protection by means of a physical barrier.
Safety device	a device (other than a guard) that eliminates or reduces the risk; it can be used alone or in combination with a guard.
Customer	the person who purchased the machine and/or who manages and uses it (e.g. company, entrepreneur, firm).
Electrocution	an accidental discharge of electric current on a human body.

### D.3 Machine and manufacturer's identification data

An example of the marking or data plate on the machine is given below:

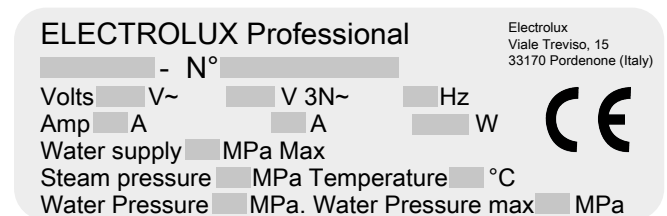

The data plate gives the product identification and technical data. The meaning of the various information given on it is listed below:

CLASSIC 123	commercial description
N°	serial number
Volts (V)	power supply voltage (monophase and/or triphase)
Hz	power supply frequency
Amp (A)	electrical intensity
W	max power input
Steam pressure (MPa)	boiler pressure
Temperature (°C)	boiler temperature
Water pressure (MPa)	water network pressure
Water pressure max (MPa)	max water network pressure
CE	CE marking
Electrolux Professional SpA Viale Treviso 15 33170 Pordenone Italy	manufacturer

The data plate is located on the front of the equipment.

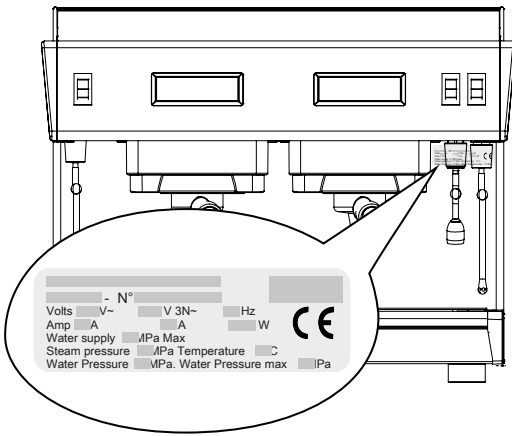

#### IMPORTANT

When installing the machine, make sure the electrical connection is carried out in compliance with that specified on the data plate.



#### NOTE!

Refer to the data given on the machine's data plate for relations with the Manufacturer (e.g. when ordering spare parts, etc.).

### D.4 Additional indications

The drawings and diagrams given in the manual are not in scale. They supplement the written information with an outline, but are not intended to be a detailed representation of the machine supplied.

The numerical values given on the appliance installation diagrams refer to measurements in millimeters and/or inches.

### D.5 Responsibility

**The Manufacturer declines any liability for damage and malfunctioning caused by:**

- non-compliance with the instructions contained in this manual;
- repairs not carried out in a workmanlike fashion, and replacements with parts different from those specified in the spare parts catalogue (the fitting and use of non-original

spare parts and accessories can negatively affect machine operation and invalidates the original manufacturer warranty);

- operations carried out by non-specialised personnel;
- unauthorized modifications or operations;
- missing, lack or inadequate maintenance;
- improper machine use;
- unforeseeable extraordinary events;
- use of the machine by uninformed and / or untrained personnel;
- non-application of the current provisions in the country of use, concerning safety, hygiene and health in the workplace.

The Manufacturer declines any liability for damage caused by arbitrary modifications and conversions carried out by the user or the Customer.

The employer, workplace manager or service technician are responsible for identifying and choosing adequate and suitable personal protection equipment to be worn by operators, in compliance with regulations in force in the country of use.

The Manufacturer declines any liability for inaccuracies contained in the manual, if due to printing or translation errors.

Any supplements to the installation, use and maintenance manual the Customer receives from the Manufacturer will form an integral part of the manual and therefore must be kept together with it.

### D.6 Copyright

This manual is intended solely for consultation by the operator and can only be given to third parties with the permission of Electrolux Professional SpA.

### D.7 Keeping the manual

The manual must be carefully kept for the entire life of the machine, until scrapping. The manual must stay with the machine in case of transfer, sale, hire, granting of use or leasing.

### D.8 Recipients of the manual

**This manual is intended for:**

- the employer of machine users and the workplace manager
- operators for normal machine use
- specialised technicians - Customer Care service (see service manual).

## E NORMAL USE

### E.1 Characteristics of personnel enabled to operate on the machine

The Customer is responsible for ensuring that persons assigned to the various duties:

- read and understand the manual;
- receive adequate training and instruction for their duties in order to perform them safely;
- receive specific training for correct machine use.

### E.2 Characteristics of personnel trained for normal machine use

The Customer must make sure the personnel for normal machine use are adequately trained and skilled in their duties, as well as ensuring their own safety and that of other persons.

The Customer must make sure his personnel have understood the instructions received and in particular those regarding work hygiene and safety in use of the machine.

### E.3 Operator qualified for normal machine use

Must have at least:

- knowledge of the technology and specific experience in operating the machine;
- adequate general basic education and technical knowledge for reading and understanding the contents of the manual, including correct interpretation of the drawings, signs and pictograms;
- sufficient technical knowledge for safely performing his duties as specified in the manual;
- knowledge of the regulations on work hygiene and safety.

In case of a significant anomaly (e.g. short circuits, wires coming out of the terminal block, motor breakdowns, worn

electrical cable sheathing, etc.) the operator for normal machine use must:

## F TECHNICAL CHARACTERISTICS

### F.1 Data table

MODELE	CLASSIC 1	CLASSIC 2	CLASSIC 3
Width	343 mm [13.5"]	642 mm [25.2"]	862 mm [33.9"]
Height	508 mm [20"]	508 mm [20"]	508 mm [20"]
Depth	568 mm [22.3"]	568 mm [22.3"]	568 mm [22.3"]
Weight	37 kg [81.5 Lbs]	55 kg [121.2 Lbs]	76 kg [167.5 Lbs]
110V single phase	1.7 kW	-	-
200V single phase	2.3 kW	3.5 kW (option 2.3)	3.5 kW
220V single phase 380V three phases + neutral	2.7 kW	4.3 kW (option 2.7)	4.3 kW
230V single phase 400V three phases + neutral	3 kW	4.7 kW (option 3)	4.7 kW
240V single phase 415V three phases + neutral	3.2 kW	5.1 kW (option 3.2)	5.1 kW
Temperature	118 to 120°C / 244 to 248°F		
Steam pressure	0.9 to 1 bar / 0.09 to 0.1 MPa		
Pump pressure	9 bar / 0.9 MPa		
High pressure valve	13 bar / 1.3 MPa		
Low pressure valve	3.2 bar / 0.3 MPa		
Dose of ground coffee	7 gr		
Dose of water	5 to 7 cl		
Infusion time	20 to 25 s		

## G INSTALLATION & ASSEMBLY

### G.1 Preparing the appliance

The appliance is delivered in a cardboard box and is screwed onto a wooden pallet.

#### Unpacking the appliance

- Cut the strapping.
- Open the crate and take out the box containing the accessories.
- Unscrew the nuts securing the appliance to the pallet.
- Separate the cardboard box from the pallet.
- Remove the appliance from the pallet and place it on wooden blocks.
- Remove the transport screws and washers.

#### Preparing the site and installing the appliance.

- Position the appliance in its final location, and level it with rubber washers if necessary.
- The appliance must be installed on a flat surface.
- It is necessary to leave a space of 50 mm [2"] at the back. Do not obstruct the air intakes provided on the top of the appliance.
- An earthed electric socket corresponding with the characteristics of the appliance and a water supply are enough.
- The canopies are put in place after the settings have been done.
- The appliance must not operate without its feet.

#### G.1.1 Fitting high feet (optional)

Reference feet : **54000**.

For fitting the high feet, once the appliance is installed in its location:

tip the appliance onto the front two feet to screw in the high feet at the base of the rubber feet at the back, and then do the same operation for bolting the feet to the front.

### G.2 Water connection

Water softener essential above 5° KH.

#### G.2.1 Water supply

- Pressure: 1 bar [0.1 MPa] and 8 bar [0.8 MPa]
- Connection: 3/8" female gas (male fitting on the appliance)

- Tube: internal  $\varnothing$ 8 mm [0.3"] minimum
- Provide a shut-off tap
- Work on the right side of the appliance:
- Unscrew the cruciform screw at the front of the side
- Slide the side toward the back
- Screw the water inlet tube to the connection in the appliance

### **G.2.2 Draining**

The appliance is delivered with a complete connection kit including a stainless steel braided water hose 2 m [78.7"] length and a drain hose 2 m [78.7"] in length with a clamp located in the box of accessories.

Connect the other end of the drain tube to a waste water drain by ensuring that no adverse slope interferes with good outflow.

- Fitting:  $\varnothing$ 18 mm (female fitting on the appliance).
- Tube: internal diameter  $\varnothing$ 12 mm minimum.

### G.3 Electrical connection

None of the switches on the appliance must be on. Check that the values of the voltage, frequency and power shown on the technical information plate of the appliance match those of the mains. Put the switch of the appliance on position 0. The appliance is delivered with a cable of 3 or 5 numbered wires (including the earth wire). It is necessary to check that the wiring of the appliance matches the available mains voltage, in accordance with the connection diagrams below. If necessary, modify by working on the power supply cable and the terminal block located in the vicinity of the pressure switch.

#### G.3.1 Connection diagrams

A =	Electronic box	1 =	BROWN PHASE
B =	Switch	2 =	BLACK PHASE
N =	NEUTRAL	3 =	GREY PHASE



#### IMPORTANT

IN ALL CASES THE GREEN/YELLOW WIRE MUST BE CONNECTED TO THE EARTH OF THE INSTALLATION

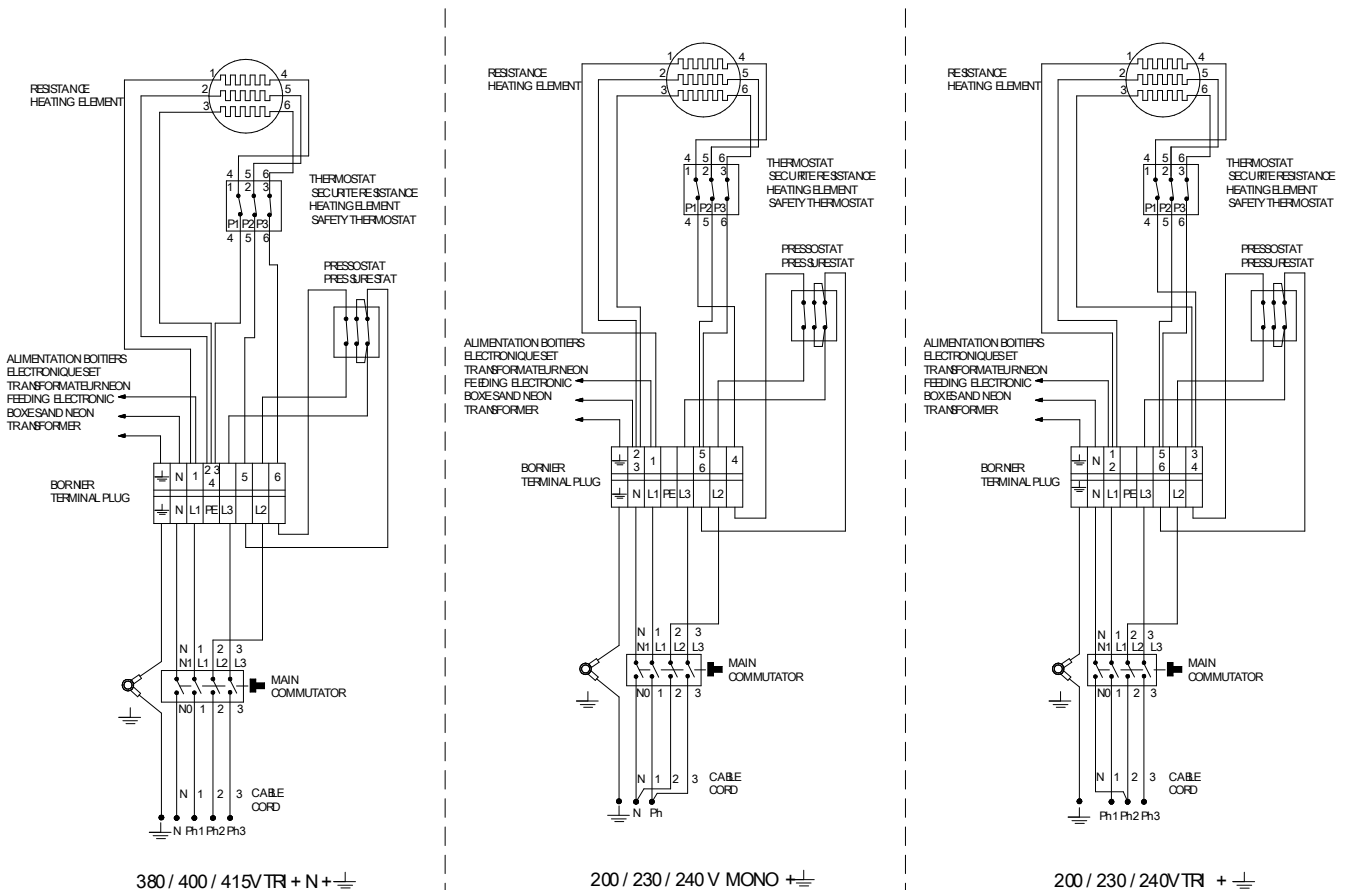

### G.4 Checks & adjustments

Usually, the adjustments are made before leaving the factory. Check that these adjustments are correct and, if necessary, change them, proceed as follows for access.

#### G.4.1 Temperature adjustment

##### By electric pressurestat

The pressure controller (pressurestat) is located at the back of the appliance. Dismantle the cup rack; remove the cover of the pressurestat to get to its adjustment screw.

- TIGHTEN to LOWER the temperature
- LOOSEN to RAISE the temperature

The pressure-gauge red scale (located on the front of the appliance) must indicate a pressure of between 0.9 bar [0.09 MPa] and 1 bar [0.1 MPa] which corresponds to a temperature of 120°C [248°F].



## G.4.2 Adjusting the expansion valve

### 1 group model

The High pressure valve is located on the right side of the appliance: it is necessary to dismantle the right side.

The valve is set above the pump; its adjusted pressure must just be greater than the water network pressure. Recommended value: 7 bar [0.7 MPa] to 8 bar [0.8 MPa] (green scale of the pressure gauge).

- If the valve opens ABOVE 8 bar [0.8 MPa]: LOOSEN
- If the valve opens BELOW 7 bar [0.7MPa]: TIGHTEN

Use the tool reference OU003; after the adjustment, do not forget to block the counter nut.

### model 2 groups or more

The HP valve is located in the lower part at the left rear of the appliance: it is necessary to dismantle the left side. The valve must open at about 13 bar [1.3 MPa] (green scale of the pressure gauge).

- If the valve opens ABOVE 13 bar [1.3 MPa] LOOSEN
- If the valve opens BELOW 13 bar [1.3 MPa] TIGHTEN

Use the tool reference OU003; after the adjustment, do not forget to block the counter nut.

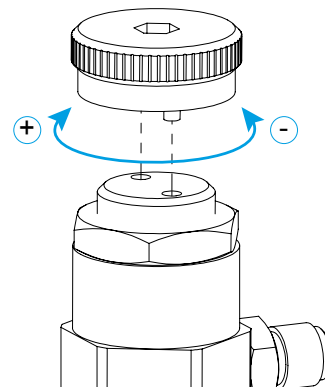

## G.4.3 Adjusting the pump pressure

During infusion, the pressure must be 9 to 10 bar [0.9 MPa et 1 MPa] (gauge green scale).

1 group model : The pump is located in the left side.

model 2 groups or more : The pump is located in the right side.

- **SCREW IN** to INCREASE the pressure
- **UNSCREW** to DECREASE the pressure

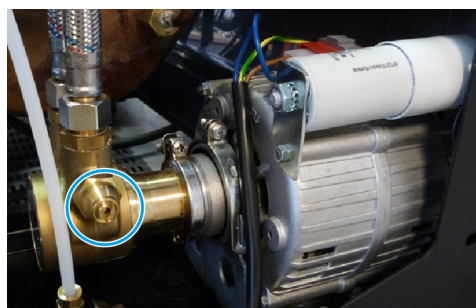

## G.4.4 Adjusting the coffee grinding

Wait until the machine has reached the set temperature 0.9 bar [0.09 MPa] and 1 bar [0.1 MPa]. It is the finesse of the grinding which determines the time for passing the hot water through the dose. This time is usually monitored by using the two-cup filter with two doses of coffee. Average passing time for 2 cups (6 to 7 cl. per cup): 30 to 35 seconds.



### NOTE!

To obtain a good result, use at least 6 g. of (good) ground coffee per cup.

- If the infusion time is shorter, reduce the grinding.
- If the infusion time is too long, increase the grinding.

## G.4.5 Softener

Test the water hardness of the network and refer to the technical documentation of the water softener used for optimum adjustment. A softener must be changed every 1 year, even if it does not reach the end of its filtering capacity.

## H OPERATING



### NOTE!

When the machine has been installed and the hydraulic, electrical connections have been carried out by a qualified installer.



## WARNING

Do not forget to open the water tap supplying the machine.

### H.1 Switching on

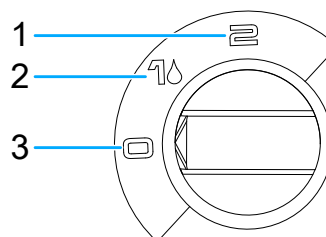

Fig. 1 Main switch

1. Heating
2. power turn ON and filling boiler(s)
3. appliance OFF

#### Turn ON the appliance:

Put the main On/Off switch on position 1 (do not put it on position 2 until the boiler is full). The On/Off indicator switches

on and the boiler level is set automatically. The water-intake indicator blinks to show that the boiler is filling.

### Heating:

When the water-intake indicator stops blinking, put the switch on position 2 to start the heating process. When the correct temperature has been reached, the steam pressure is approximately 0.9 to 1 bar [0.09 to 0.1 MPa].

## H.2 Keyboards

### H.2.1 Electronic coffee box

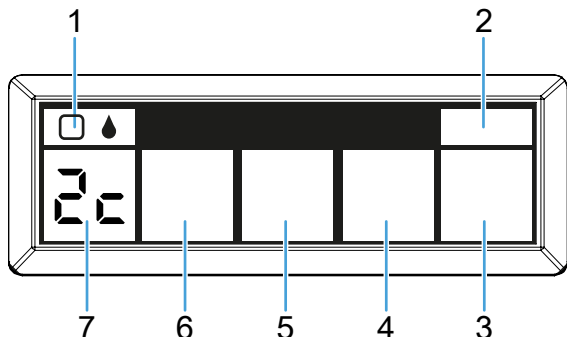

1. Safety level control (by LED)
2. Continu/stop icon
3. Coffee icon (depends option chosen)
4. Coffee icon (depends option chosen)
5. Coffee icon (depends option chosen)
6. Coffee icon (depends option chosen)
7. Display

## H.3 Programming

The icons from ③ to ⑥ can be programmed. The multiple doses (1, 2 or 3 cups ) are calculated automatically from the programming of one of them on each box:

- Set the machine switch to Position 0.
- Keep the icon ② pressed and put again the machine on. Display shows Pn then Pc and Pr by pressing several times the key ②.

### H.3.1 Pc = Calculated programming

- Insert a filter-holder (with coffee) into the unit.
- Install cups.

- |  |  |
|--|--|
| <p>② </p> <p>③ to ⑥ </p> <p>② </p> <p>② </p> | <p>Display shows Pc.</p> <p>Select the dose to be programmed (2c for example).</p> <p>Start the infusion cycle.</p> <p>Press again to stop when the amount of coffee desired is correct. Display of the corresponding digital value (from 00 to 99).</p> |
|--|--|

- Repeat operation at 3 for the other doses (2C for example)

### H.3.2 Pn = Digital programming

Quick programming without coffee and/or values carried forward on other units.

- |  |   |
|--|---|
| <p>② </p> <p>③ to ⑥ </p> <p>② </p> <p>⑥ </p> <p>③ </p> <p>② </p> | <p>Display shows Pn.</p> <p>Select the dose to be programmed.</p> <p>Display the digital value of the selected dose.</p> <p>Increase the value.</p> <p>Reduce the value.</p> <p>Memorize the new value.</p> |
|--|---|

Repeat operation at 4 for the other doses.

### H.3.3 Pr = Manual programming

Same proceeding as in calculated programming Pc.

- The manual programming doesn't calculate the other doses (1, 2 or 3 cups), only the programmed dose is modified.
- Caution: any new programming (Pn or Pc) cancel ALL previous programmed values.
- Wait until the program mode is automatically inactivated (from 10 to 15s), or switch OFF and ON again the machine.

## H.4 Configuration of different keyboards

### H.4.1 2-cup units (type d2)

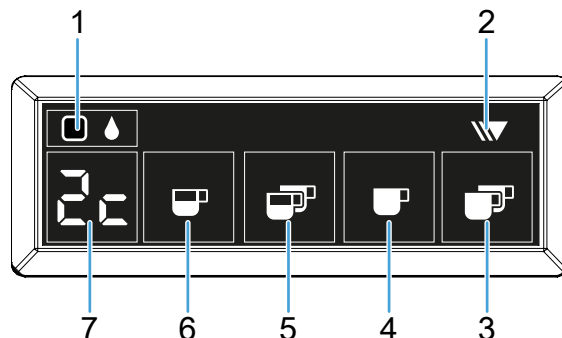

1. Safety level control (by LED)
2. Continu/stop icon
3. 2 large cup icon
4. 1 large cup icon
5. 2 small cup icon
6. 1 small cup icon
7. Display

#### H.4.1.1 Use and doses to programme

4 doses of coffee and 1 Continuous / Stop manual function are available. During the infusion, the display indicates:

- or = 1 or 2 small cups
- or = 1 or 2 large cups
- = Continuous / Stop

At any time, you can change the selection by pressing another icon. The dosage is automatic but the infusion can be stopped manually by pressing the Continuous / Stop icon.

Programming: as the multiple doses are calculated automatically, two programming only are necessary (1c or 2c) and (1C or 2C).

#### H.4.1.2 Configuration parameters

- |   |   |
|---|---|
| <p>dn / dt</p> <p>C0 / C1 / C2</p> <p>A0 / A1</p> | <p><b>For the automatic calculation of multiple doses:</b><br/>dn = normal dose<br/>dt = dosing with "Torino" kit</p> <p><b>timed for the infusion time:</b><br/>C0 = no timer<br/>C1 = display of the infusion time<br/>C2 = display of dynamic time</p> <p><b>Authorization to programme:</b><br/>A0 = programming prohibited<br/>A1 = programming authorized</p> |
|---|---|

After switching on, the display shows, in order, the following information:

- the version number of the electronic memory: eg. r1
- the type of unit: D2
- the active operating parameters: eg. dn, CO, A1

#### H.4.1.3 Modification of the configuration of parameters

- Shut down the appliance (0/1 switch).

- Press the two keys **3** and **6** at the same time, and at the same time, switch the appliance back on.
- Press the **3** icon to change the selection (eg. dn or dt).
- Press the **2** icon to change the selection (eg. dn / dt dosing of Chrono). C0/C1).
- Switch off to exit the configuration mode or wait until the automatic exit after 10s.

- Keep the end-piece of the steam tube at the surface to obtain a fine foam.
- After each use, clean the steam tube with a wet rag and press a moment on the steam tap to eliminate the small amount of milk remaining in the tube.



NOTE!

Be careful to not boil the milk

## H.5 How to prepare a cappuccino

- Use a high narrow container half-full of cold milk (preferably skimmed).

# I CLEANING

## I.1 Coffee cleaning



NOTE!

for the following process use a 2 cups filter-holder and the rubber plug reference DO197 inside.

### I.1.1 Rinsing of decompression circuit

- Insert and tight the filter-holder in the unit.
- Press a coffee icon to put the filter-holder under pressure, and then stop the unit. Repeat this operation several times, each time removing the water from the filter-holder.

### I.1.2 Weekly cleaning with detergent pellet

Take the 2 cups filter-holder and place the rubber plug (DO197) inside the filter.

- Put a detergent pellet above the rubber plug then insert and tighten the filter-holder in the unit.
- Keep pressed the touch **2** then press the touch **3**. (display shows nP).



NOTE!

if chrono mode activated, press twice on the touch **2** before pressing touch **3**.

- Press again touch **2** to start the automatic cycle (2s On / 8s Off – x 10 sequences).
- When the display shows rP: take off the filter-holder from the unit and wait the end of the rinsing cycle (3 x 30 seconds).
- At the stop of the automatic cycle: put back the filter holder without the plug and without coffee then start a 2 large cups cycle to rinse it.

## I.2 External cleaning

### Steam output tube:

After each use, clean the steam outlet with a damp cloth and release steam for a short time to eliminate the mall residue of milk which has been able to remain in the tube. (Remove the tip of the steam pipe for easier cleaning).

### Rinsing the decompression circuit:

- Engage the cup on the unit by tightening it.
- Press a coffee touch to pressurize the cup, and then stop the unit. Repeat the operation several times by emptying the water contained in the cup each time.

### Basin grille

Remove the basin grille by lifting it up from the front. Clean the basin with a sponge.

### Bodywork

Use a soft cloth and alcohol for the stainless steel parts, and a nonabrasive cleaning agent for the painted parts. Simply take care not to scratch the painted parts.

### Keyboards cleaning



IMPORTANT

Never clean keyboard with liquid when the machine is in normal operation.

- Turn OFF the machine by main switch (position 0).
- Clean the keyboards and the front panel with a smooth towel and an adequate cleaning product.
- When the cleaning is done, turn ON the main switch (position 2).

## J MAINTENANCE

### J.1 Preventive maintenance

Reference		Description	Quantity			Frequency			
	ELUX		1 group	2 groups	3 groups	6 month	1st, 3rd & 5th years	2nd & 4th years	6th year
<b>Group service</b>									
27800	0UN122	GASKET - 2.62 X 52.07	1	2	3	✓	✓	✓	✓
PC17	0UN128	HEAD GASKET 9MM	1	2	3	✓	✓	✓	✓
23127	0UN131	GICLEUR ø0.7 KIT	1	2	3		✓	✓	✓
31910		WASHER DIFFUSER	1	2	3		✓	✓	✓
50200		SCREW - M5 X 10	1	2	3		✓	✓	✓
ID103	0UN103	PACKER FILTER	1	2	3		✓	✓	✓
<b>Steam/Water Wands Service</b>									
PH78		O RING - 9,13 X 2,62	2	3	3	✓	✓	✓	✓
PH54	0UN133	O RING - 13.95 X 2.62	2	3	3	✓	✓	✓	✓
AG14		COPPER GASKET	2	3	3		✓	✓	✓
PA43		SPRING	2	3	3		✓	✓	✓
RR67		BRASS END	2	3	3		✓	✓	✓
<b>Steam Valve Service</b>									
CN489		SCREW - M4 X 16	1	1	1		✓	✓	✓
NZ4014		STEAM HANDLE INSERT	1	1	1		✓	✓	✓
NZ7003		STEAM HANDLE	1	1	1		✓	✓	✓
25925		CERAMIC CARTRIDGE	1	1	1		✓	✓	✓
<b>General service</b>									
27200		LOW PRESSURE VALVE 1/8"	1	1	1		✓	✓	✓
27845	0UN144	O RING - 2.62 X 17.13	1	1	1		✓	✓	✓
CN198		GASKET - 6.07 X 1.78	1	1	1		✓		
CN2850		GASKET - 10.82 X 1.78	2	2	2		✓		
27224		VACUUM VALVE KIT						✓	✓
PE28	0UN102	GASKET - 36,09 X 3,53	1	2	3			✓	✓
27737	0UN085	O RING - 6,07 X 1,78	2	4	6			✓	
CN828	0UN008	GASKET - DOSING DEVICE	1	2	3			✓	✓
CN829	0UN086	TURBINE	1	2	3			✓	✓
CN670		LEVEL PROBE L=130	1	1	1			✓	✓
NA70		LEVEL PROBE COMPRESSION NUT	1	1	1			✓	✓
NA71		LEVEL PROBE INSULATION	1	1	1			✓	✓
<b>Complete 6 Year Service</b>									
PI45X		WHOLE SOLENOID VALVE WITHOUT COIL	1	2	3				✓
CN827	0UN004	WATER DOSING DEVICE LED	1	2	3				✓
CN245W		SOLENOID VALVE 2W WITHOUT COIL	1	2	2				✓
28352	0UN017	GASKET - 20 X 12 X 2	1	2	2				✓
AE53A		PRESSURESTAT UL	1	1	1				✓
CN618		GASKET - 11.4 X 6.2 X 1	1	1	1				✓
37206		PUMP 100L/H	1						✓
37207	0UN056	PUMP 200L/H		1	1				✓
37222		COUPLING KIT	1	1	1				✓
CV20	0UN090	GASKET - 66.68 X 3.53	1	1	1				✓
CN631W		SOLENOID VALVE 2W ADJ. WITHOUT COIL	1	1	1				✓
25400	0UN124	FILTER FOR SOLENOID VALVE 1/8"	1	1	1				✓
DV203		WASHER 1/4" ø2	2	3	3				✓
DO191	0UN136	COMPLETE HIGH PRESSURE VALVE	1	1	1				✓
28134	0UN019	O RING - 2 X 9,5	3	6	6				✓
CH16		WASHER - COPPER - 3/8"	3	2	2				✓

## K TROUBLESHOOTING



### SAFETY INFORMATION

- A. Switch off the machine before any work on the electrical circuits.
- B. Cool the machine and make the pressures drop before any work on the hydraulic circuit.

#### K.1 Faults reported by the electronic display

##### K.1.1 Problems related to the electronic box control keys

If the display shows **P1**, **P2**, **P3**, **P4** and **P5** this means that the corresponding key is short-circuited and is no longer usable.

- Check that the front face is not deformed
- Change the box.

##### K.1.2 Problems of fuses

The display shows **F-**

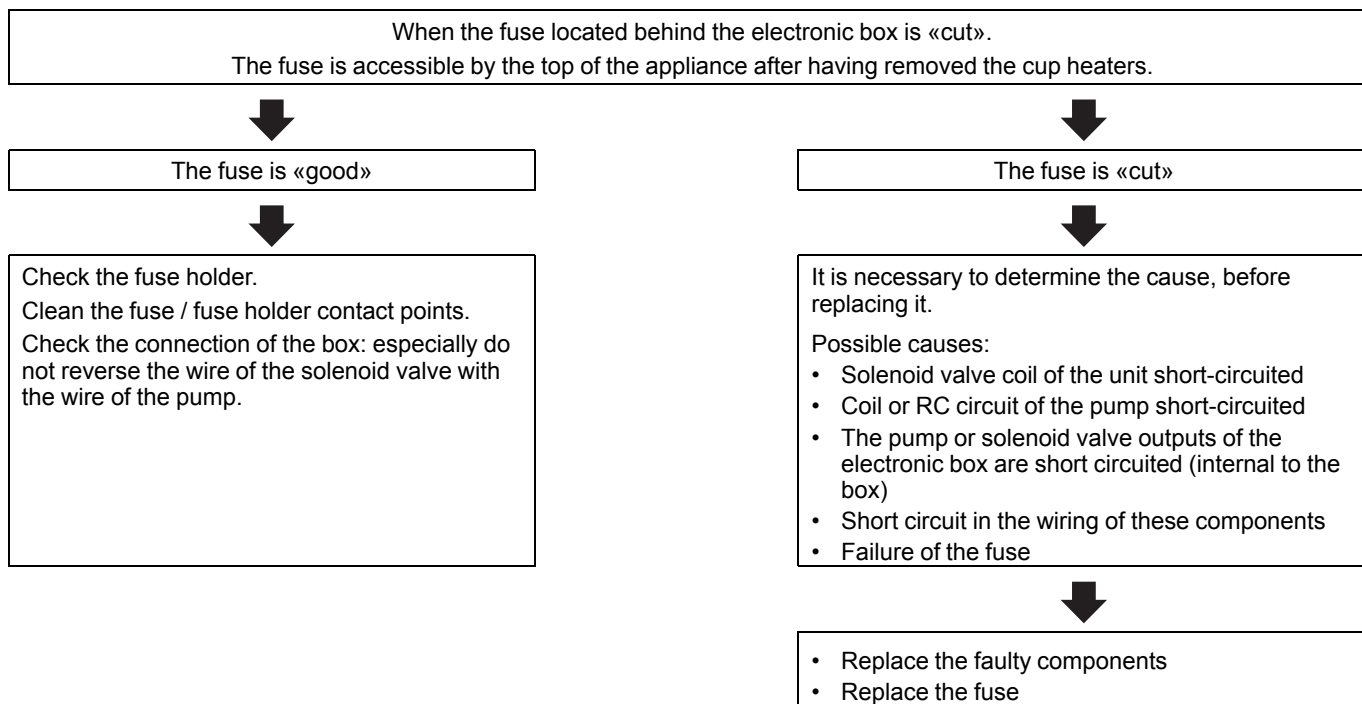

##### K.1.3 Dosing problems

###### K.1.3.1 Safety 105 seconds of the coffee unit

The displays shows **t**

This safety device limits the maximum time of infusion to 1 minute and 45 seconds. This makes it possible to stop the infusion automatically if the volumetric meter no longer works or if the flow rate is too low, in order to protect the pump and the solenoid valve of the unit.

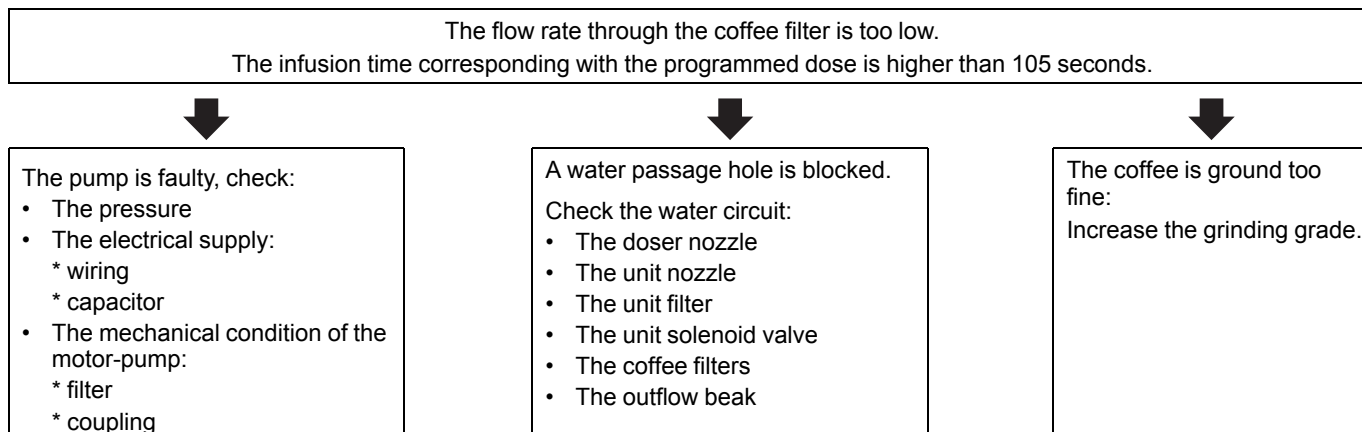

### K.1.3.2 Counting safety

During the infusion, the display shows **cd**. this means that the doser has no longer sent pulses to the electronic box of the group for 5 seconds. If the interruption of counting has only been momentary, the infusion will be stopped when the number of pulses counted will correspond with the programmed number of pulses. Of course, the dose obtained will be greater. If the interruption is permanent, the infusion is stopped automatically 105 seconds after the start of the infusion and the display will show: **cc** or manually by the “Continuous / Stop key” and the display will indicate **cd**.

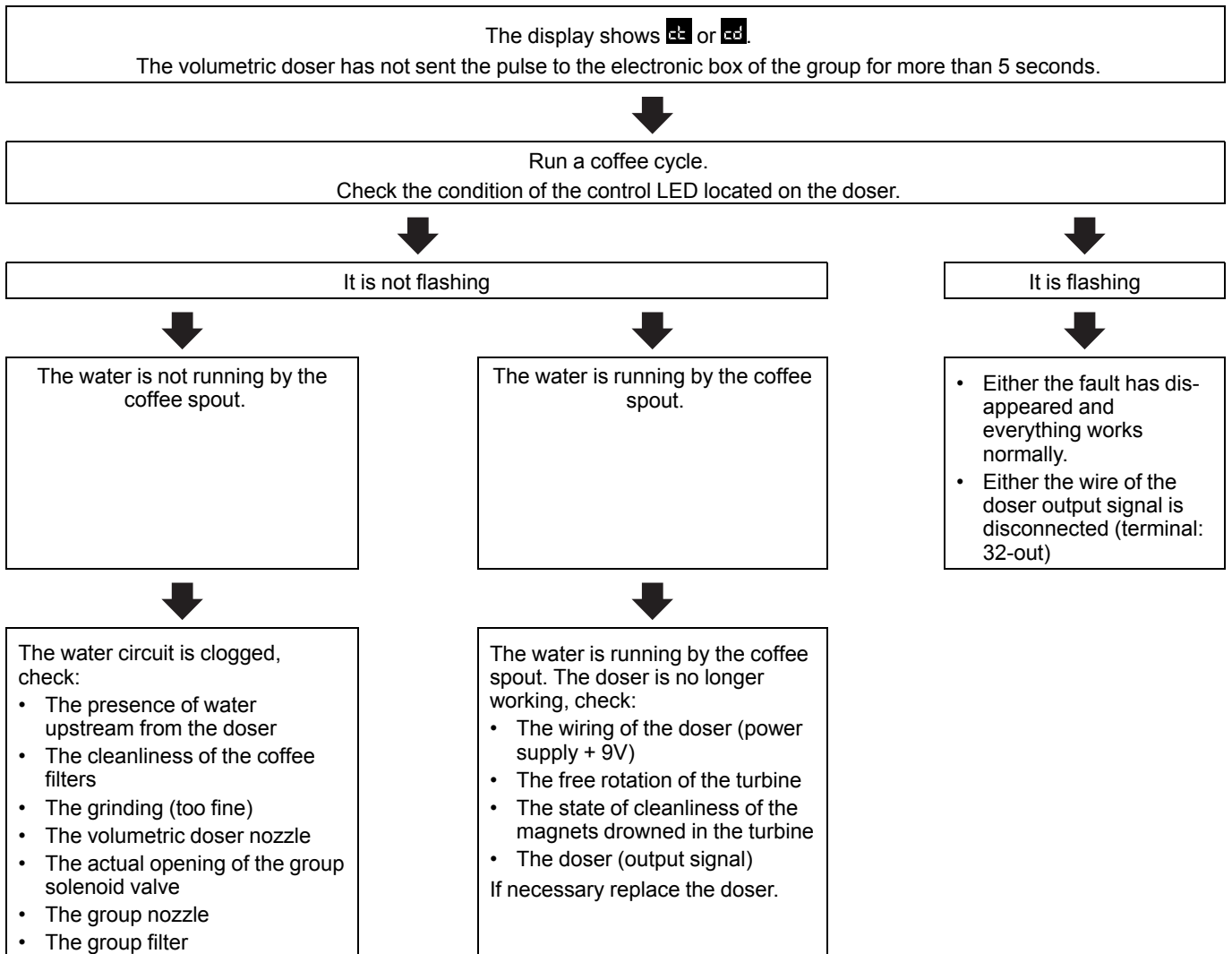

### K.1.3.3 Doser safety

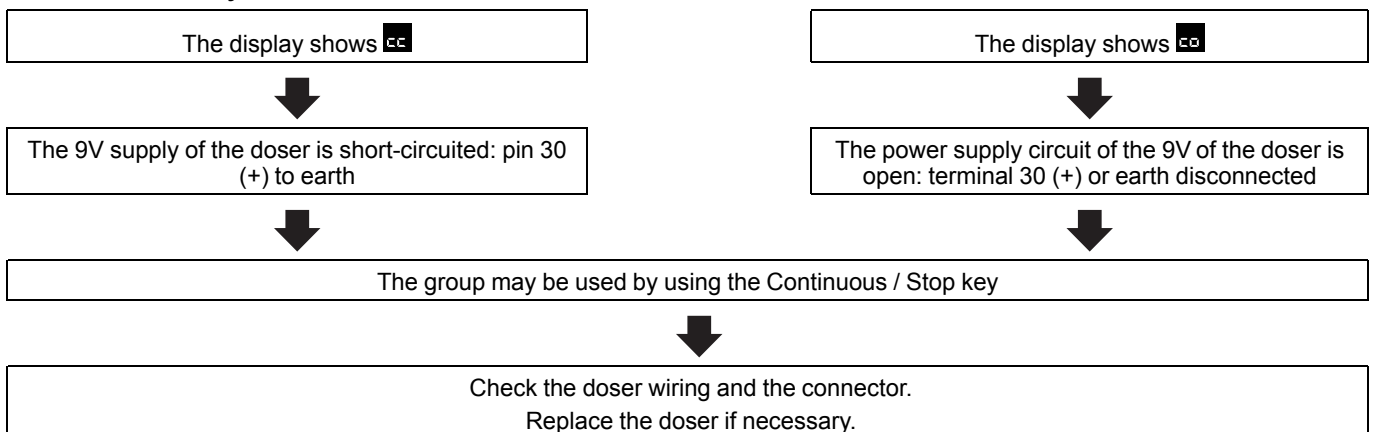

#### K.1.4 Other faults

##### K.1.4.1 Water problems of the coffee unit

###### Doses below the programmed doses

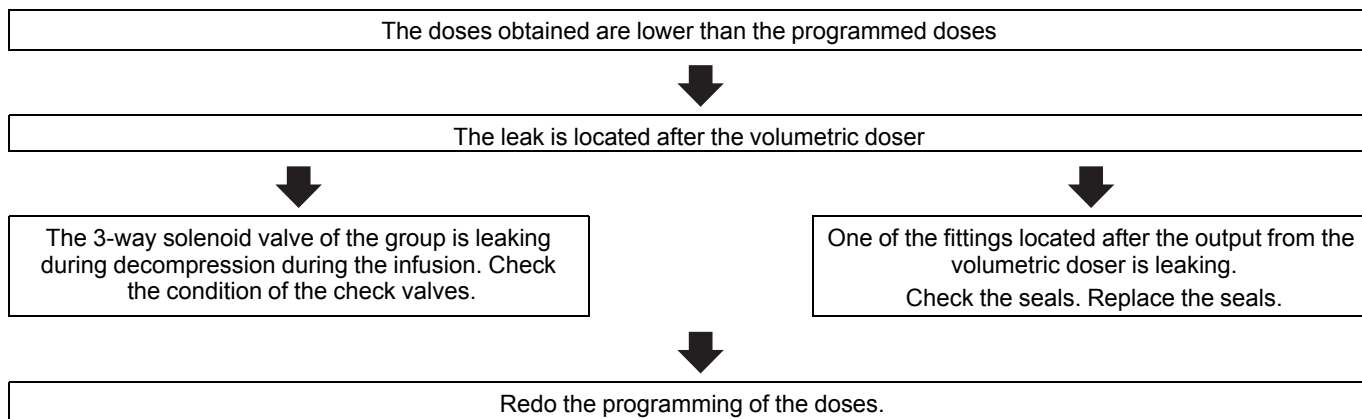

###### K.1.4.2 Dripping outside the infusion periods

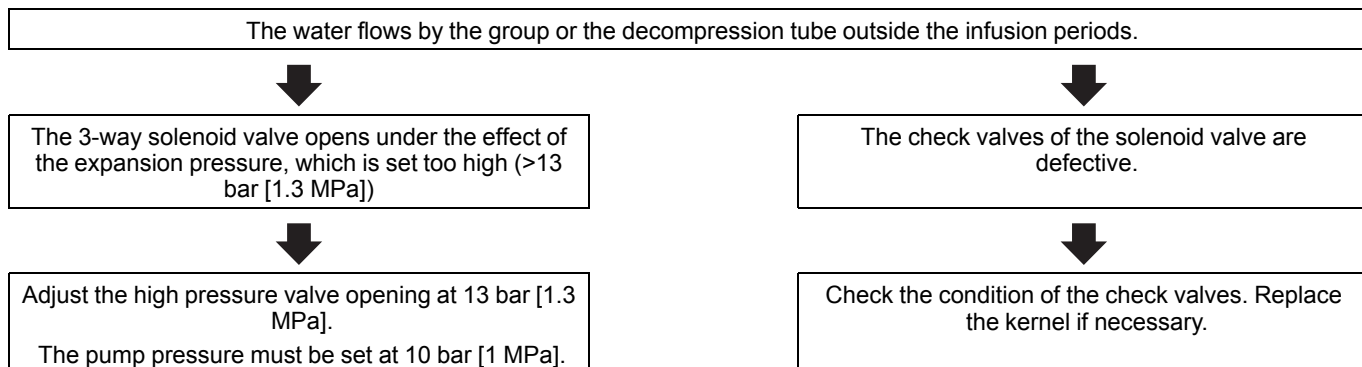

###### K.1.4.3 Infusion pressure too low

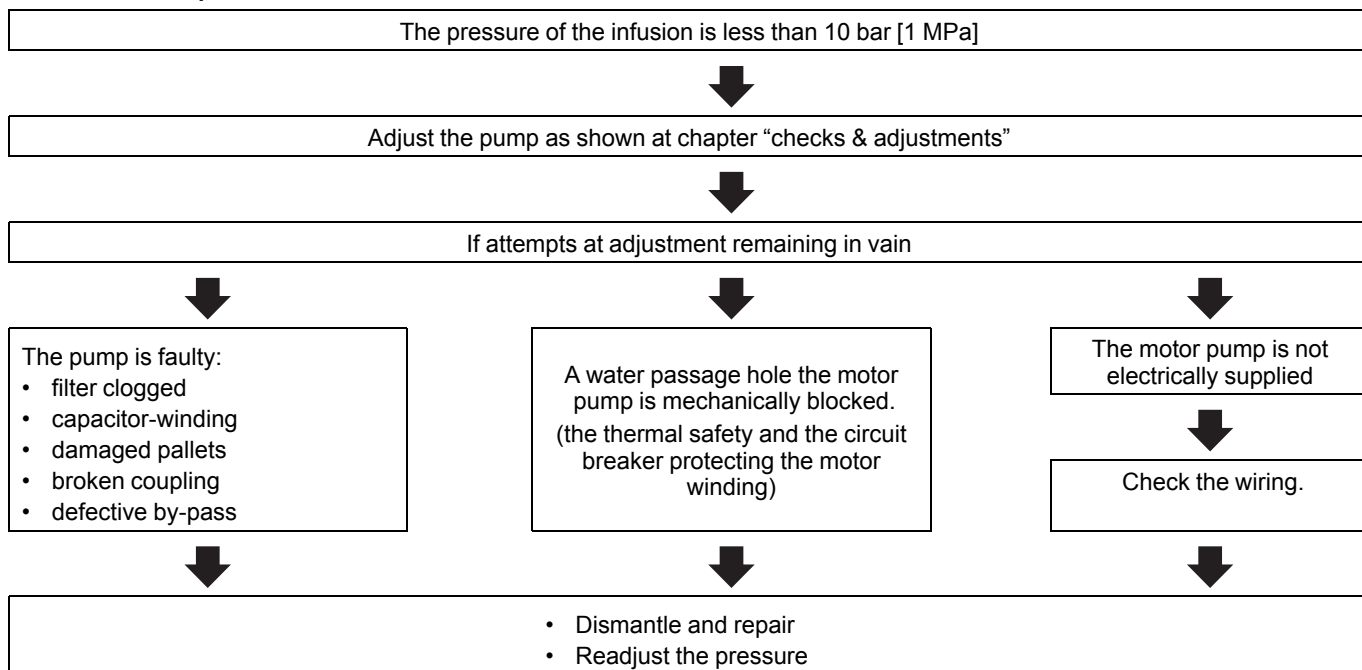

#### K.1.4.4 Bad decompression

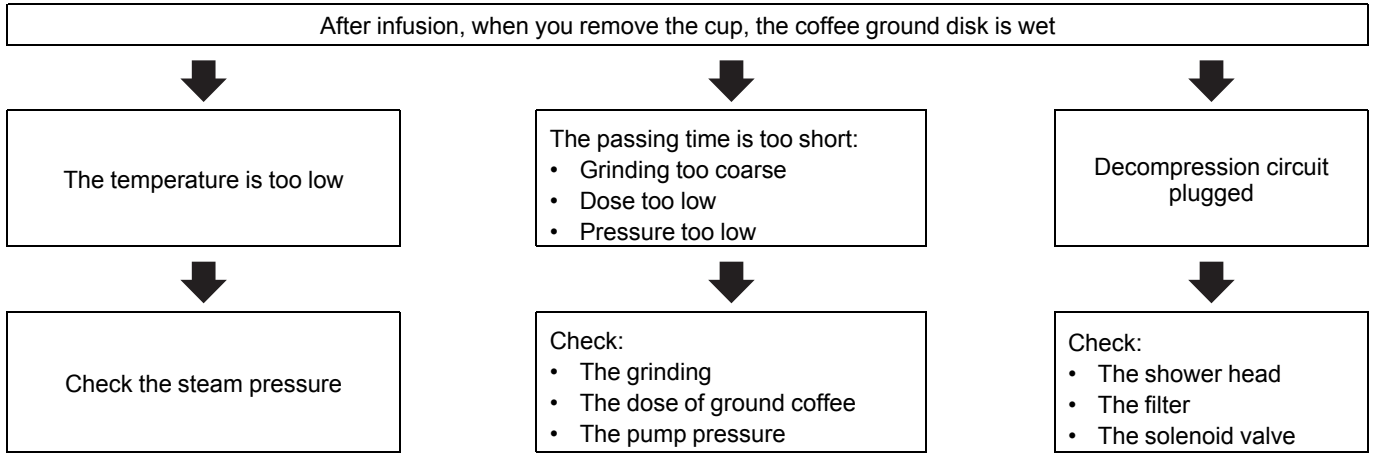

#### K.1.5 Level adjustment problems

##### K.1.5.1 The steam boiler is flooded

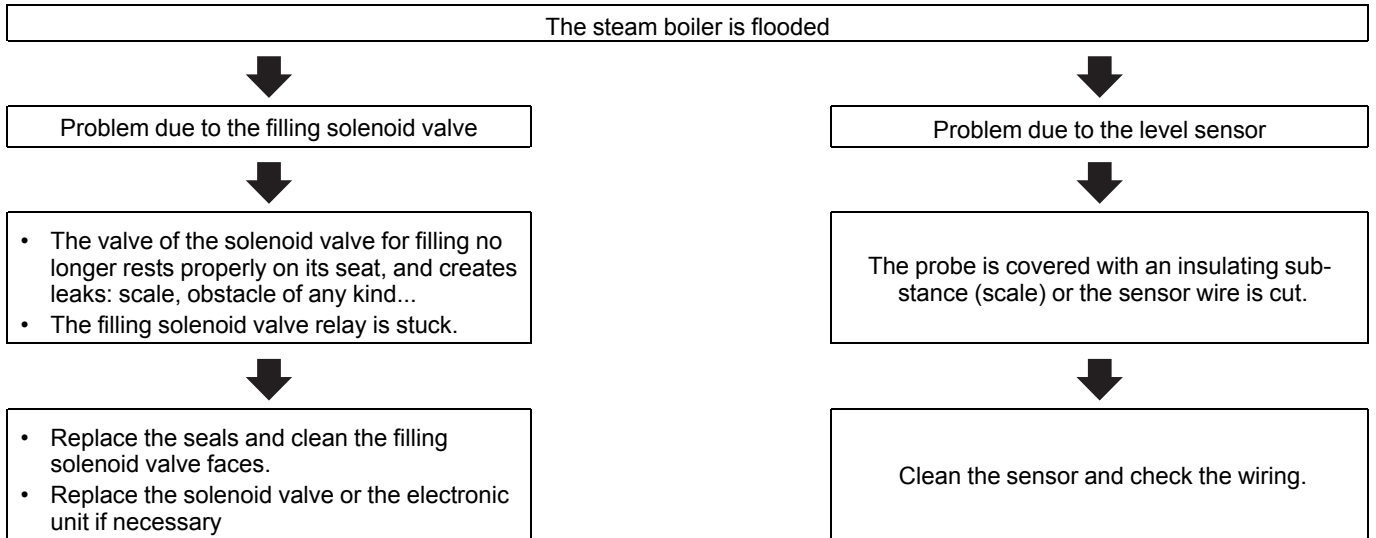

##### K.1.5.2 The boiler is empty

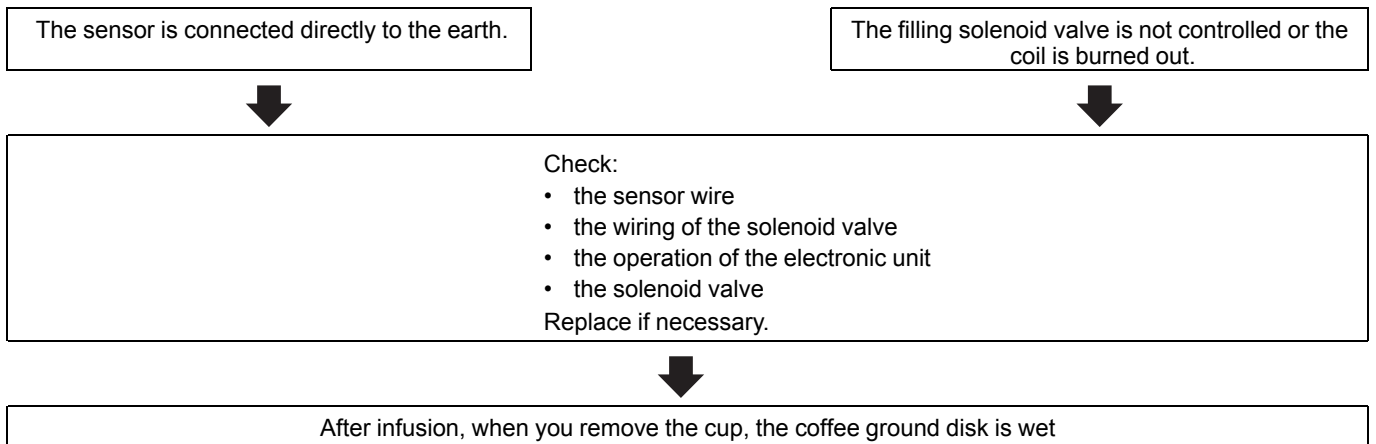

### K.1.6 Unable to programme

Programming is impossible



- Check the unit configuration
- A0: Programming prohibited
  - A1: Programming permitted



Display of a safety signal:

- to Safety key
- : Fuse
- : Time
- / : Doser



Refer to the corresponding paragraph for repair

### K.1.7 The “heating doesn’t follow

- After a few cups of coffee continuously, the appliance is «cold».
- Check the passage time and adjust the grinding.
- Check that each pin of the heating resistor works.



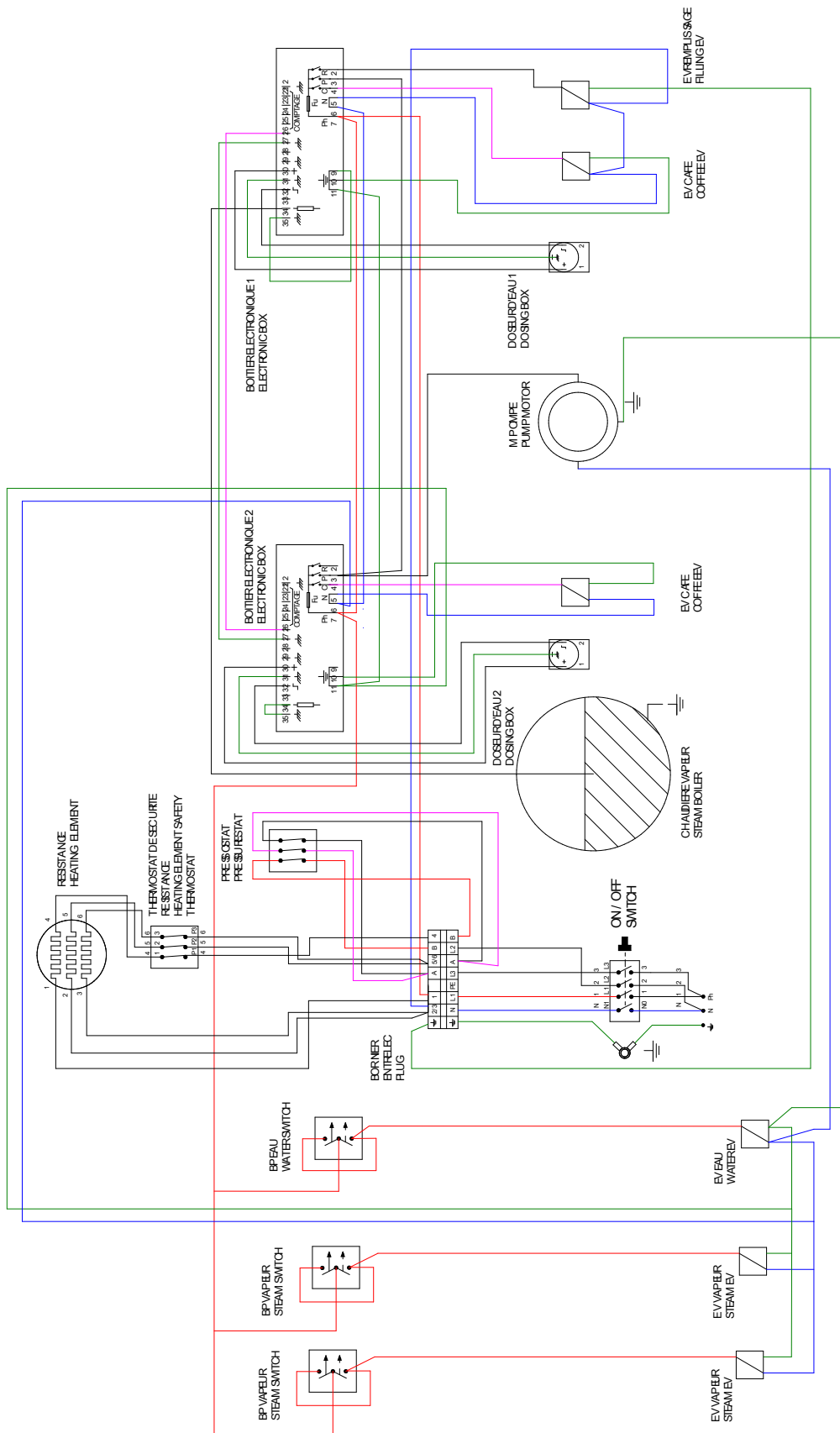

Fig. 3 Wiring diagram for CLASSIC 2 [230V MONO]

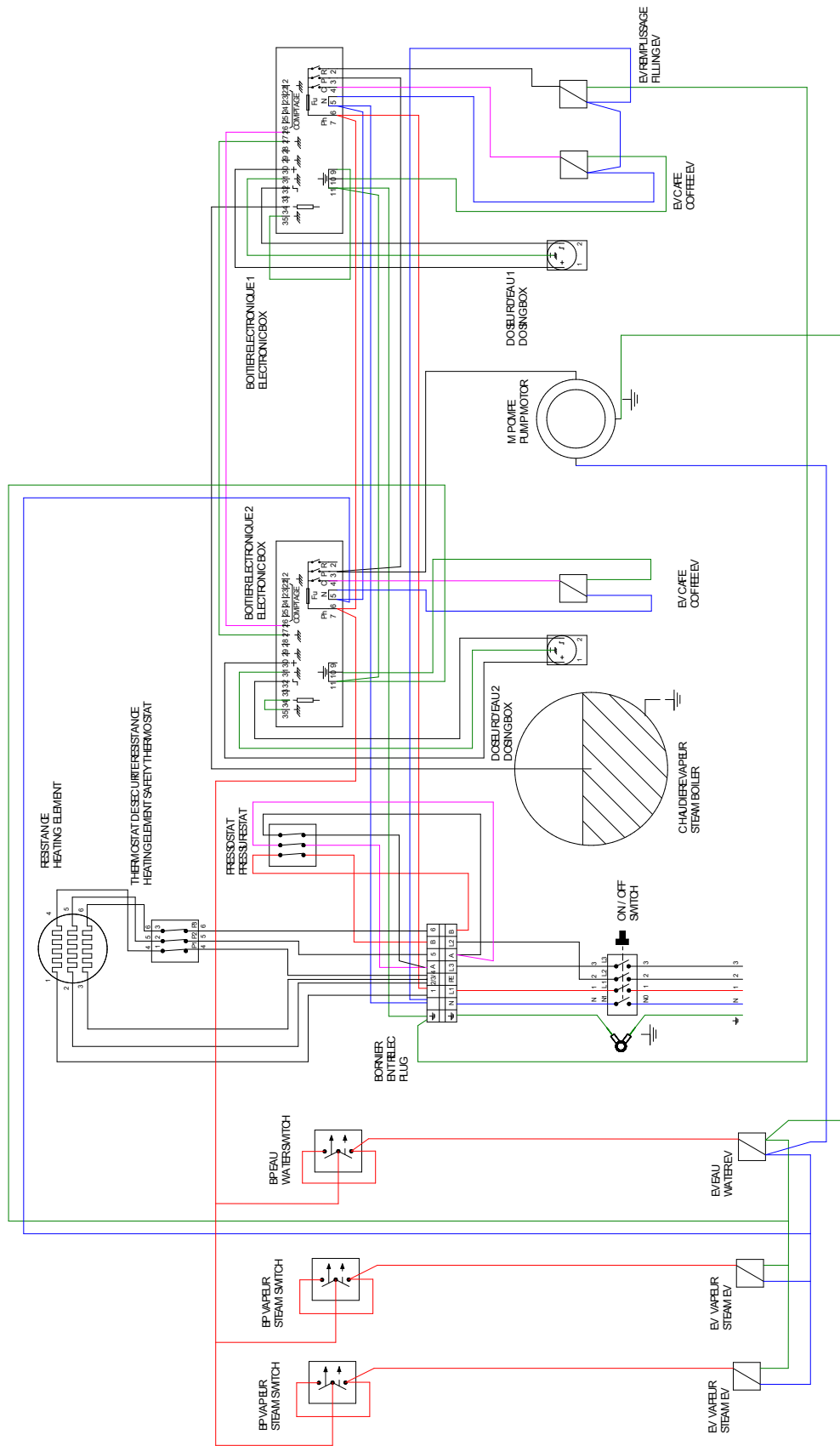

Fig. 4 Wiring diagram for CLASSIC 2 [380V TRI]

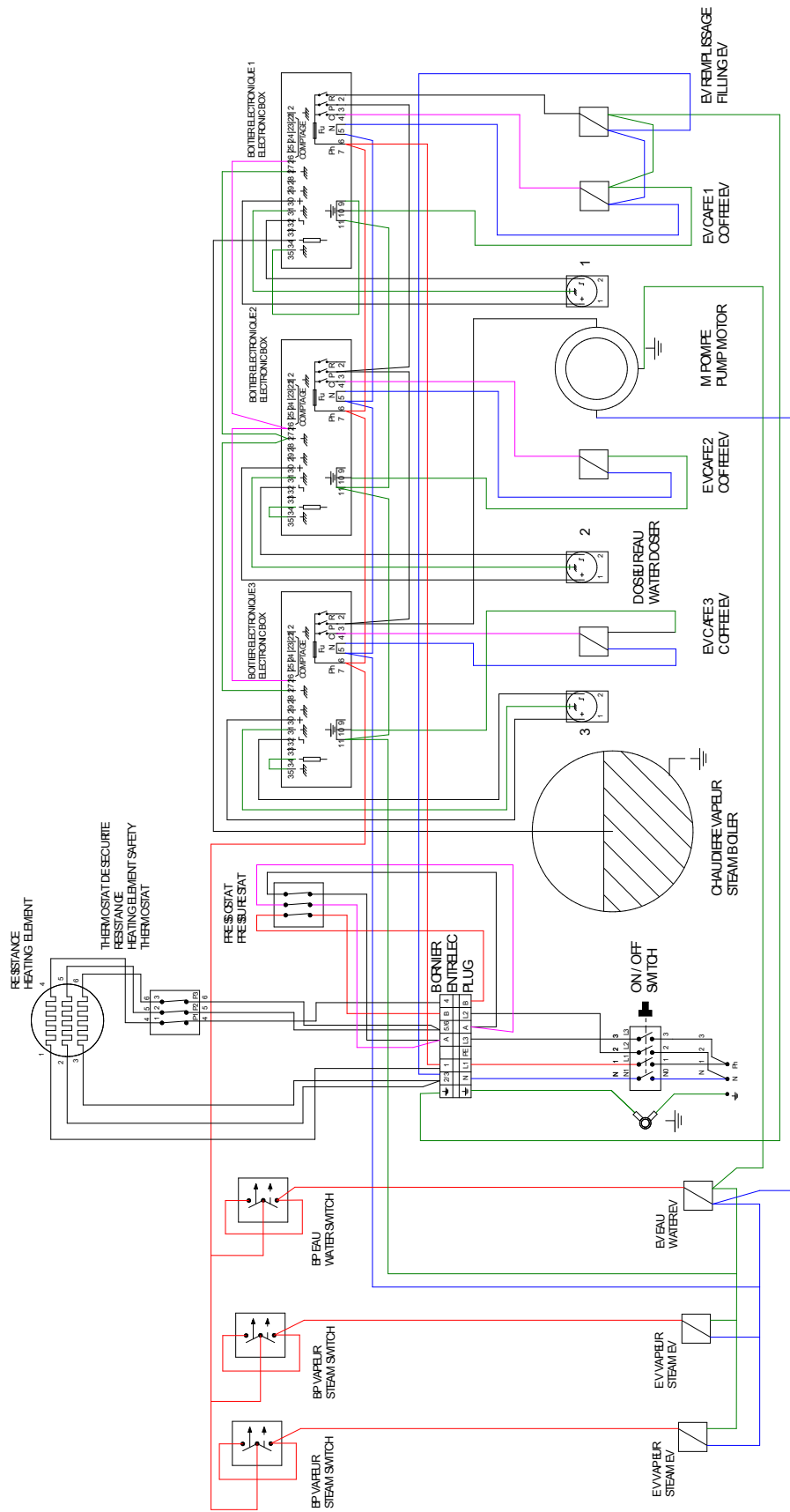

Fig. 5 Wiring diagram for CLASSIC 3 [230V MONO]

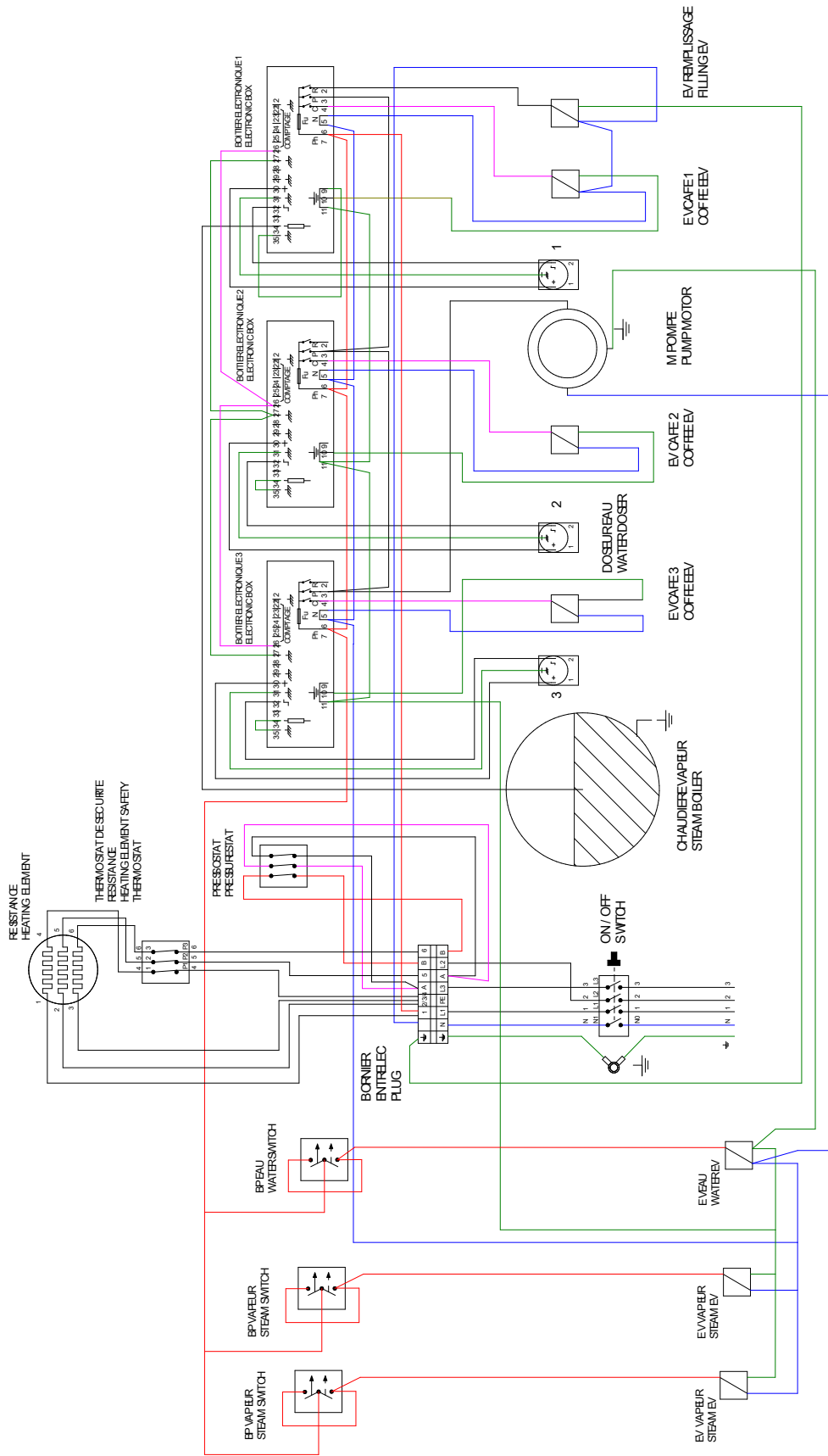

Fig. 6 Wiring diagram for CLASSIC 3 [380V TRI]





CE

Electrolux Professional SPA  
Viale Treviso 15  
33170 Pordenone  
[www.electroluxprofessional.com](http://www.electroluxprofessional.com)