

TECHNICAL NOTE

stella
★ ★ ★ ★ ★ ★ ★ ★
epic



All reproduction rights of this manual are reserved to **UNIC SAS**. Reproduction, even partial, is prohibited.

Descriptions and illustrations relate to the specific machine/equipment in question. **UNIC SAS** reserves the right to introduce appropriate modifications to the machine/equipment in production at any time.

This manual:

is an integral part of the supply and must be read carefully in order that the machine is properly used, in compliance with essential safety requirements

has been drafted in accordance with the provisions of **Machinery Directive 2006/42/EC** and provides the technical information necessary to properly perform all procedures in conditions of safety

must be carefully preserved (protected in a transparent and waterproof cover to avoid deterioration) and must accompany the machine throughout its life, including any changes of ownership. In case of loss or damage, it is possible to request a copy from **UNIC SAS**, reporting the data shown on the identification plate

UNIC SAS declines any responsibility for improper use of the machine/equipment and/or for damage caused by operations not provided for in this manual.

Doc No : **SE9010**
EN

Table of contents

▶ Safety instructions	5
◻ INSTALLATION	6
▶ Preparing the machine	6
♦ <i>Unpacking the machine</i>	6
♦ <i>Preparing the site and installing the machine</i>	6
▶ Water connection	6
▶ Electrical connection	7
♦ <i>Electrical connections</i>	7
♦ <i>Connection diagrams</i>	7
▶ Verification of the toroidal transformer with respect to the mains voltage	8
▶ Starting up	8
♦ <i>Filling the boilers</i>	8
♦ <i>Steam boiler</i>	8
♦ <i>Unit boilers</i>	9
♦ <i>Heating</i>	9
▶ Checks & adjustments	9
♦ <i>Temperature setting</i>	9
♦ <i>Adjusting the expansion valve</i>	9
♦ <i>Adjusting the pump pressure</i>	10
♦ <i>Adjusting the water inlet solenoid valve</i>	10
♦ <i>Adjusting the coffee grinding</i>	10
♦ <i>Adjusting the mixer tap for hot water</i>	10
♦ <i>Adjusting the basin</i>	10
◻ USE & PROGRAMMING	11
▶ Interface	11
♦ <i>Description of the 4 dose BGX menu</i>	11
♦ <i>Description of the Dosamat BGX menu</i>	11
♦ <i>Description of the BTA menu</i>	12
♦ <i>Various icons</i>	13
▶ Main menu	14
▶ Day/night programming	15
▶ Counters	15
▶ Settings	16
▶ Other settings	17
▶ Use	18
▶ Cleaning	19
▶ Maintenance	20
▶ Details of settings menu	21
♦ <i>Language</i>	21
♦ <i>Choice of language</i>	21
♦ <i>Customisation</i>	21
♦ <i>Choice of type of keyboard</i>	21
♦ <i>Screensaver</i>	21
♦ <i>CIM</i>	21
♦ <i>Saving</i>	22
♦ <i>Levels of access</i>	22

▶ Details of Other settings menu	23
♦ <i>Probe calibration</i>	23
♦ <i>IT connection</i>	23
♦ <i>Connectivity</i>	23
▶ Details of Use menu	24
♦ <i>Hot water & steam</i>	24
♦ <i>Dosamat</i>	24
♦ <i>Infusion profiles</i>	24
♦ <i>Standard mode</i>	24
♦ <i>Expert mode</i>	25
△ MAINTENANCE & REPAIRS	27
▶ Cleaning	27
♦ <i>After each use</i>	27
♦ <i>Steam outlet tube</i>	27
♦ <i>Daily</i>	27
♦ <i>Before use or after several hours of inactivity:</i>	27
♦ <i>After the service</i>	27
♦ <i>Weekly</i>	27
♦ <i>Filter holder cup</i>	27
♦ <i>Basin</i>	27
♦ <i>Bodywork</i>	27
▶ Details of the coffee cleaning Procedure menu	28
♦ <i>Coffee rinsing</i>	28
♦ <i>Coffee cleaning</i>	28
♦ <i>Reference of cleaning products</i>	28
♦ <i>option SteamAir</i>	29
♦ <i>Components</i>	29
♦ <i>key SteamAir</i>	29
♦ <i>Programming</i>	29
▶ Details of the Maintenance menu	30
♦ <i>Components test</i>	30
♦ <i>Softener</i>	30
♦ <i>Descaling</i>	30
♦ <i>Machine cooling</i>	31
♦ <i>Error log</i>	31
▶ Preventive maintenance	32
▶ Repairs	37
♦ <i>Troubleshooting</i>	37
♦ <i>Technical features</i>	37
♦ <i>CPU connectors & fuses</i>	38
♦ <i>Cable lists</i>	39
♦ <i>Plate assembly</i>	41
♦ <i>Wiring diagrams</i>	42
♦ <i>Procedure for updating the machine</i>	45
♦ <i>Assembly/replacement procedures</i>	47
♦ <i>Mother board replacement (CPU)</i>	47
♦ <i>BTA/BGX/BST box replacement</i>	47
♦ <i>Cup seal</i>	48
♦ <i>List of error codes</i>	49

► Safety instructions

This appliance is intended to be used only for its specific use.
The manufacturer disclaims any liability for damage caused by abnormal use or abuse.

Children 8 years of age or older and persons with reduced physical, mental or sensory abilities, or lack of experience and skill may use this appliance, if supervised by a qualified person, or they have received the instructions for use and safety necessary to understand the risks involved.

Supervise children to make sure they do not play with the appliance; they must not be allowed to clean or maintain it.

Do not leave packaging elements within reach of children. These elements are potentially a source of danger.

The installation must be done by a qualified technician and following local and national regulations. They are the only people authorised to access the internal parts of the appliance for maintenance and repair.

Only use the technical and spare parts manuals to ensure correct operation of the machine, and do not compromise safety.

Access to the service area is restricted to persons with the necessary knowledge of safety and hygiene as well as practical experience of the appliance.

Leave enough space around the machine for easy use and access if any repair intervention is required.

The appliance **must not** be:

- exposed to elements of the external environment or placed in damp places,
- exposed to a water jet or splashing.
- installed in areas where jets or high pressure cleaners are used.

The appliance **must** be:

- placed on a stable, level and horizontal surface
- used at ambient temperature of 5°C to 35°C (41°F - 95°F), (if it is stored at an ambient temperature below 5°C (41°F), the water circuit (boiler-piping) must be drained).
- if the appliance freezes, wait 24 hours at a minimum temperature of 10°C (50°F) before restarting it.

Before connecting the power and water supplies, check that the electrical and water mains comply with the technical information plate of the appliance.

The power supply must be provided with the following safety features: power switch which completely isolates the machine from the mains (gap between contacts of at least 3 mm), efficient earthing and an effective circuit breaker for protection against earthing leaks; section of the conductors appropriate for a power capacity.

Before connecting or disconnecting the power cable, switch the main switch to position 0.

If the power supply cable is damaged, it must be replaced by the manufacturer, by its after-sales service technician or similarly qualified persons, to avoid any danger.

For electrical safety, make sure that the appliance is properly earthed.

The manufacturer disclaims any liability for damage caused by improper earthing.

The appliance must be connected to the water mains with a pressure of 1 to 8 bar (0.1 to 0.8 MPa) and a tap readily accessible must be fitted in front of the water supply tube.

The appliance is to be installed with adequate backflow protection to comply with applicable federal state and local codes.

In case of an emergency (fire, surge, abnormal noise, etc.), the first thing to do is to cut off the power supply and close the water tap.

Be careful not to obstruct the air inlets of the machine with cloths or other objects.

Beware of hot surfaces such as cup warmers, the unit heads and the hot water and steam outlets.

Never place containers filled with liquids on top of the machine

Never expose it to hot water or steam jets.

The machine should be descaled only by a qualified technician.

△ INSTALLATION

► Preparing the machine

The machine is delivered in a cardboard box and is screwed onto a wooden pallet.

◆ Unpacking the machine

- Cut the strapping.
- Open the crate and take out the box containing the accessories.
- Unscrew the nuts securing the machine to the pallet.
- Separate the cardboard box from the pallet.
- Remove the machine from the pallet and place it on wooden blocks.
- Remove the transport screws and washers.

◆ Preparing the site and installing the machine

- Position the machine in its definitive location.
 - The machine must be installed on a flat surface.
 - It is necessary to leave a space of 5 cm at the back. Do not obstruct the air intakes provided on the top of the machine.
 - An earthed electrical socket corresponding to the characteristics of the machine and a water supply are sufficient.
- (The machine must not operate without its feet)

► Water connection

A water softener is essential above 5° KH

Water inlet:

- Pressure: 1 - 8 bar (0.1 MPa - 0.8 MPa).
- Fitting: 3/8 female gas (male fitting on the machine).
- Tube: internal diameter 8 mm minimum.
- Provide a shut-off tap.

Intervention underneath the machine at the centre:
Screw the water inlet tube onto the fitting in the machine (photo opposite).

Draining:

- Fitting: Ø18 mm female (at the back of the basin)
- Tube: internal diameter 12 mm minimum.
- Fitting: Ø12 mm female (on the bottom of the machine in the centre)
- Tube: internal diameter 10 mm minimum.

The drain tube is supplied fitted on the machine.

Then connect the other end of the drain tube to a waste water drain by ensuring that no adverse slope interferes with good outflow.

NOTE: The tube with the smallest diameter must not include a goose neck.

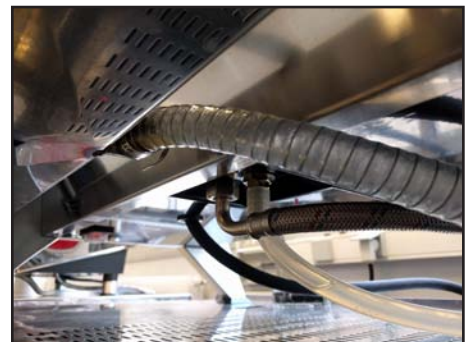
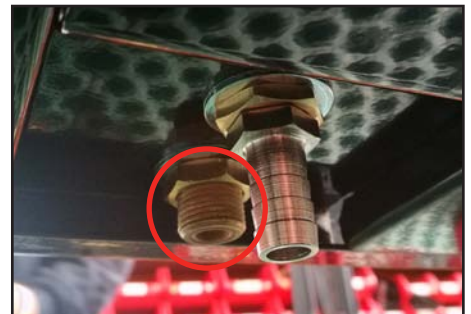

► Electrical connection

- None of the switches on the machine must be left on.
- Check that the values of the voltage, frequency and power shown on the technical information plate of the appliance match those of the mains.

◆ Electrical connections

IMPORTANT: The machine must be connected to a line fitted with a general cut-off.
The machine is delivered with a cable of 5 numbered wires.

Set the general cut-off to 0 before the intervention.

Check that the wiring of the machine matches the available mains voltage, in accordance with the connection diagrams below. If necessary, modify by working on the jumpers on the terminal block located on the left-hand side of the machine.

IMPORTANT:

Connection to 230 V with 5-strand cable, it is necessary to couple the wires at the end of the cable correctly. Single-phase 230V connection: blue and black wires together, brown and grey wires together. Watch the amperage (32 A)

Connection in 230V 3-phase: brown and grey wires together. Important: there is no neutral so the blue wire must be connected to a phase

◆ Connection diagrams

1 = GREY PHASE
2 = BROWN PHASE
3 = BLACK PHASE

IN ALL CASES THE GREEN/YELLOW WIRE MUST BE CONNECTED TO THE EARTH OF THE INSTALLATION

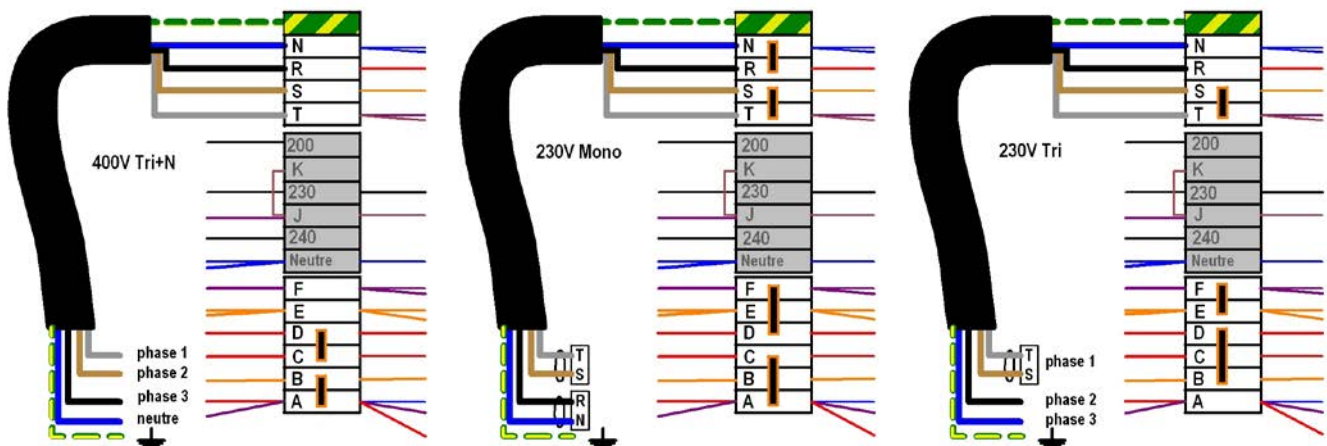

I = ponts a mettre en place en fonction de la tension du réseau

380V / 400V / 415V TRI + N +

200V / 230V / 240V MONO +

200V / 230V / 240V TRI +

► Verification of the toroidal transformer with respect to the mains voltage

The machine has a multi-voltage transformer to guarantee the right mains voltage for the electronics. The machine is factory-fitted according to the destination country. E.g.:

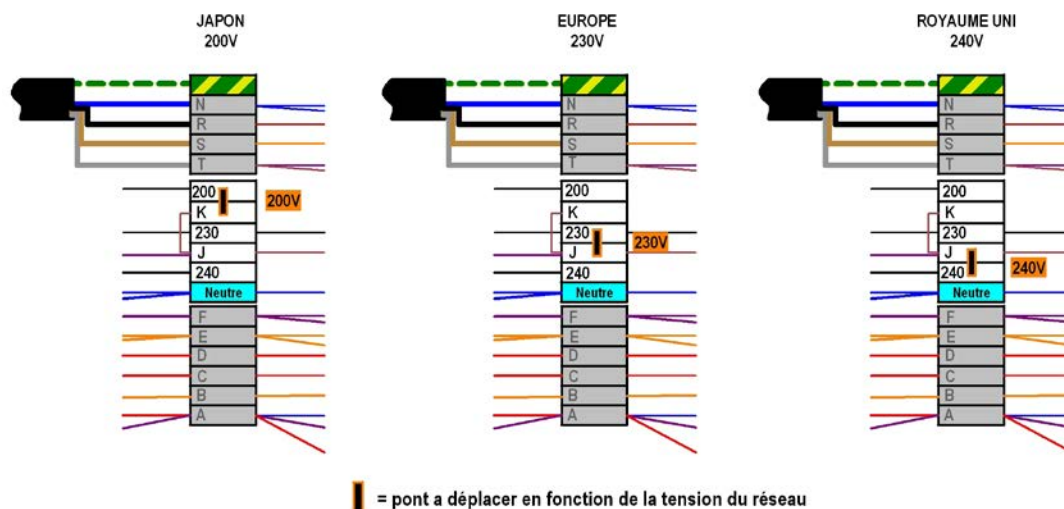

Should it be necessary to modify the factory assembly, it is only necessary to intervene on the jumpers: no cables need to be displaced.

► Starting up

When the machine is switched on, it runs an initialisation that checks all components. The start-up time lasts about **45 seconds**.



Start-up screen



Control screen

◆ Filling the boilers

- Open the water shut-off tap
- Connect the mains electric plug.
- Turn the switch to the ON position.

◆ Steam boiler

When the switched on, the filling is done automatically.

A safety mechanism is provided if the filling is not done within 3 minutes. In this specific case, the solenoid valve for filling and the pump cut off.

- Check the machine's water supply.
- Shut down and restart the machine by turning the switch to OFF then ON.
- The filling starts again for 3 minutes.

◆ Unit boilers

A small quantity of water needs to flow from each unit.

If not, the upper keys of the default unit flash:

Check the machine's water supply.

- Shut down and restart the machine: turn the switch to OFF then ON.

Refilling starts again.

◆ Heating

Heating of all elements starts automatically if correctly filled. When the operating temperature of the machine is reached, the machine is operational.

The steam pressure and temperature of the units are visible on the screen.

It is advisable to leave the machine heating permanently on and leave the filter holders engaged onto the machine when not infusing.

The menu is not accessible as long as the machine is not hot. Once the machine is hot, just press the screen to access the menu.

► Checks & adjustments

Usually, the adjustments are made before leaving the factory. Check that these adjustments are correct and, if necessary, change them, proceed as follows for access:

It is necessary to remove the right side of the machine:

Loosen the 3 mm BTR screws a few rotations at the bottom of the machine (1), between the two straight feet.

Use the suction pad (2) to remove the side by tipping it (3) upwards.

(Be careful to support the element which is heavy!)

◆ Temperature setting

The temperature of each unit and the steam boiler are adjusted independently from the control screen in the "Use" menu. (See p:24)

◆ Adjusting the expansion valve

The valve is on the front right-hand side of the machine

It can be adjusted the control screen

The valve must open at about 13 bar during heating

Use a lug wrench (ref.: OU003).

- If it opens ABOVE 13 bar: **UNSCREW**
- If it opens BELOW 13 bar: **SCREW IN**

After this adjustment, do not forget to block the lock-nut.

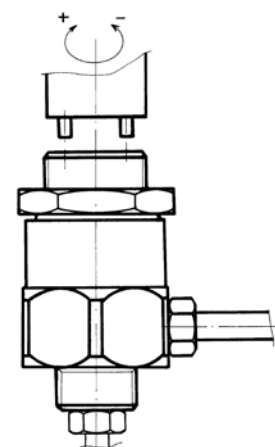
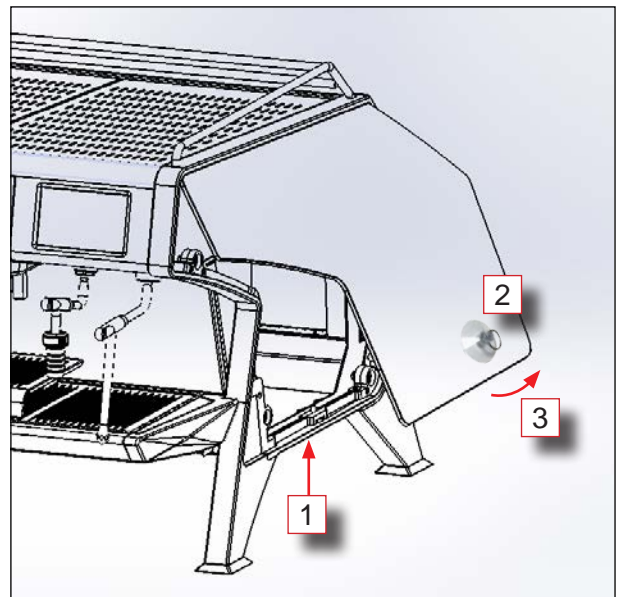

◆ Adjusting the pump pressure

When infusing, the pressure must be 9 to 10 bar (0.9 MPa et 1 MPa), display on the control/settings screen.

The pump is located on the right-hand side of the machine and is adjusted on this same side.

SCREW to INCREASE pressure,
UNSCREW to REDUCE pressure,

◆ Adjusting the water inlet solenoid valve

The water inlet solenoid valve is on the right-hand front of the machine. It is accessed from the front of the machine.

When the machine has reached its operating temperature, start a cycle (with coffee) continuously on each unit simultaneously. Induce the boiler to fill up (by drawing hot water).

Adjust the maximum flow rate of the solenoid valve so as not to fall below 7 bar (0.7 MPa).

Then check that the filling time of the boiler is not excessive.

◆ Adjusting the coffee grinding

Wait until the machine has reached the set temperature 0.9 to 1 bar (0.09 MPa to 0.1 MPa).

The coarseness of the grinding determines the time needed for hot water to pass through the dose. This time is usually controlled by using the two-cup filter with two doses of coffee.

Average time to make 2 cups (6 to 7 cl. per cup): 30 to 35 seconds.

- If this time is shorter, reduce the grinding coarseness.
- If this time is too long, increase the grinding coarseness.

To obtain a good result, use at least 6 g of (good) ground coffee per cup.

◆ Adjusting the mixer tap for hot water

The mixer tap is located on the top, on the right-hand front of the machine. To adjust it, it is necessary to remove the right side.

The temperature range is approximately 55°C to 95°C (131°F à 203°F), to adjust the required temperature, use a flat screwdriver. The adjustment is done on the cold water solenoid valve (if it is not already open, open the hot water solenoid valve to its maximum).

Always make adjustments during the hot water cycle.

If you make adjustments without drawing any hot water, as the water is incompressible, you could damage the elements of the water circuit.

SCREW to INCREASE the temperature
UNSCREW to REDUCE the temperature

◆ Adjusting the basin

On the **Stella EPIC** range, the basin can be adapted to the products required by the user.

5 positions possible, clearance of 115 mm maximum.

The adjustment is done manually by two triggers located below on the sides of the basin.

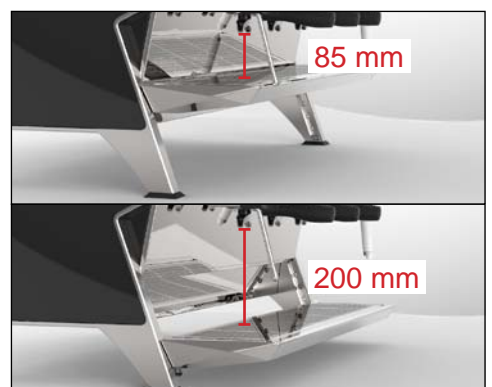
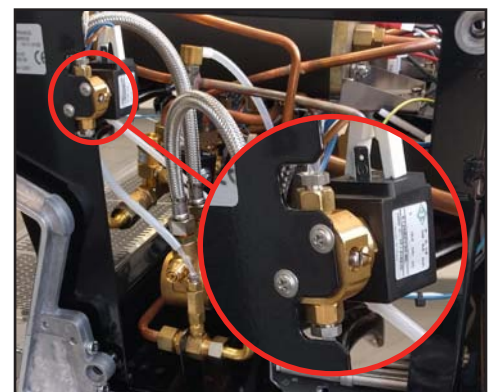
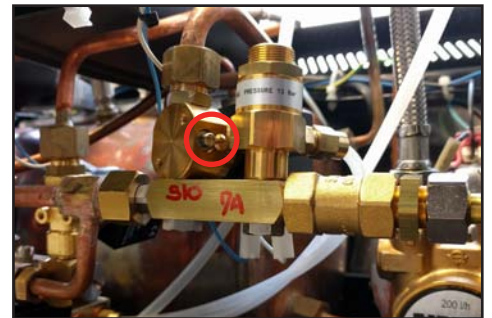

△ USE & PROGRAMMING

► Interface

◆ Description of the 4 dose BGX menu

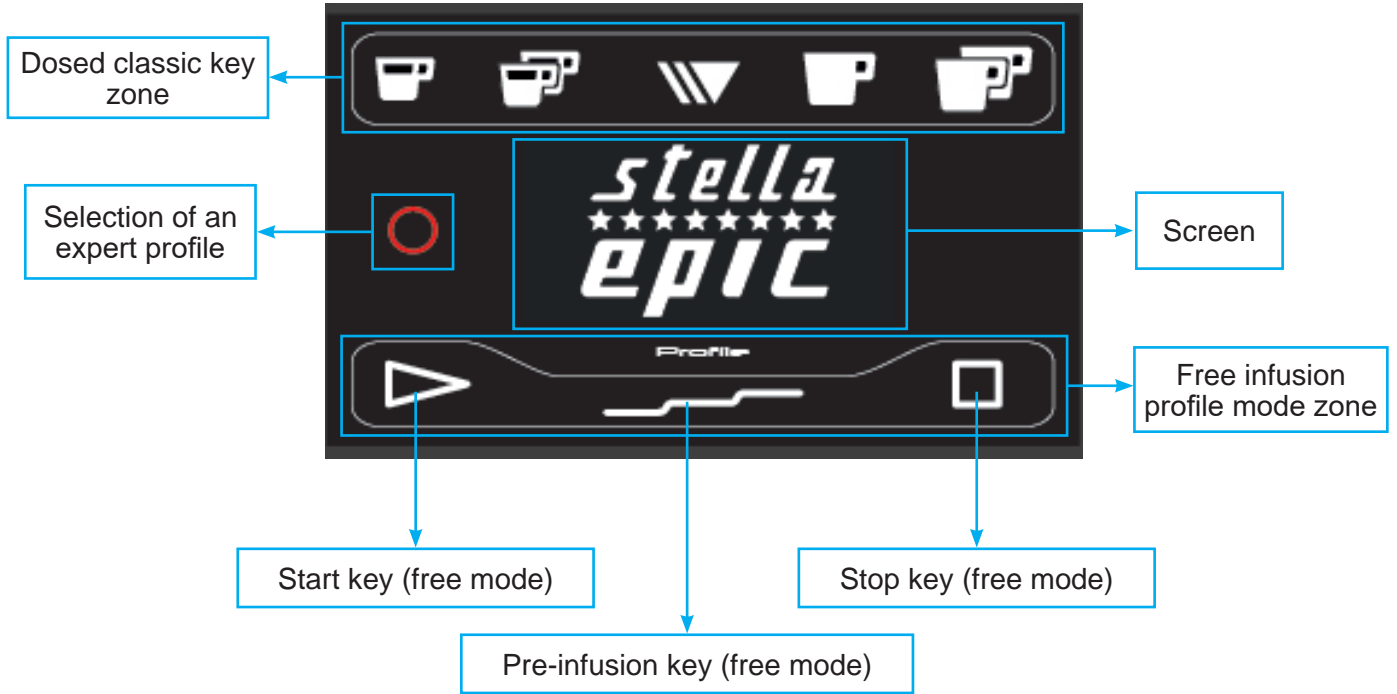



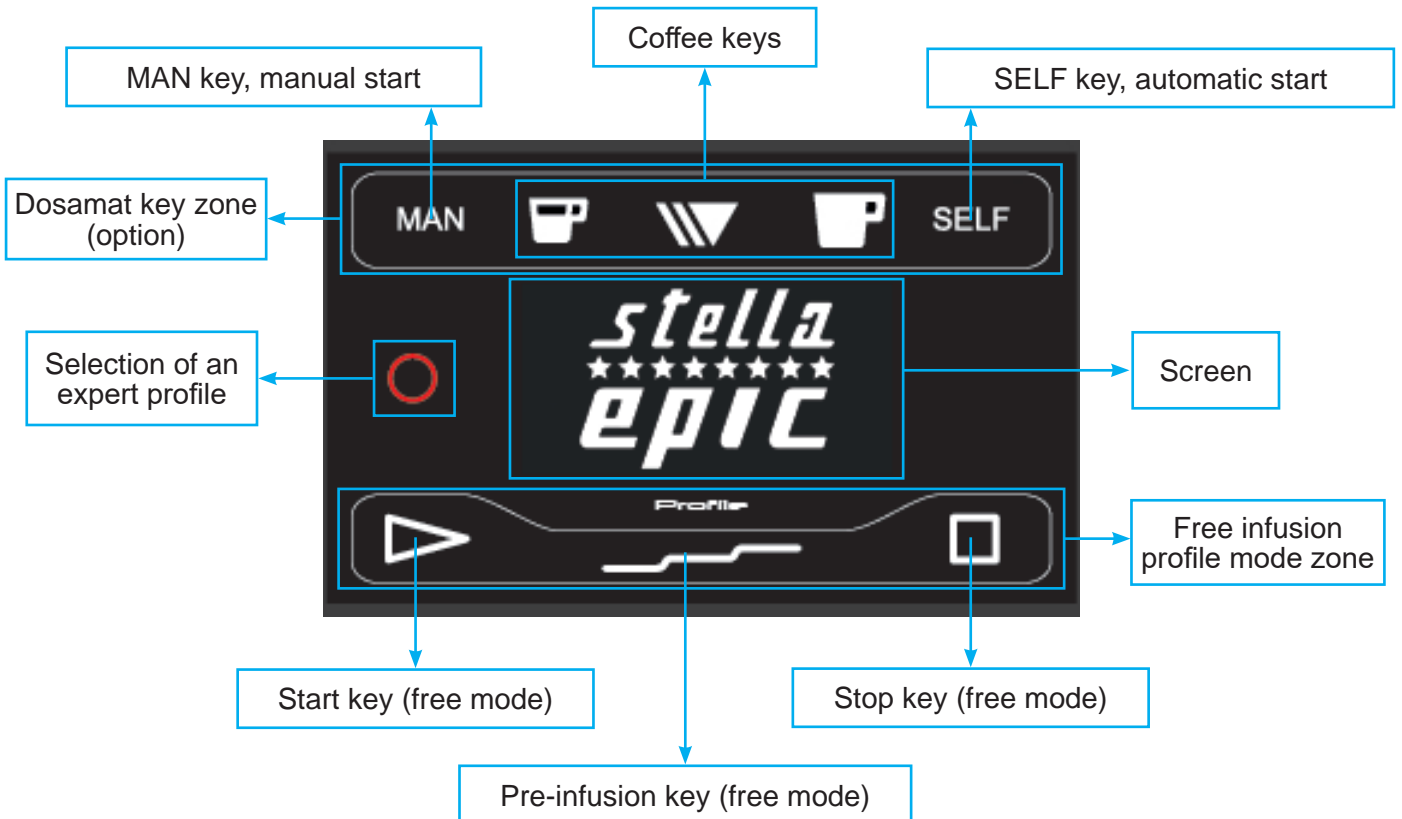



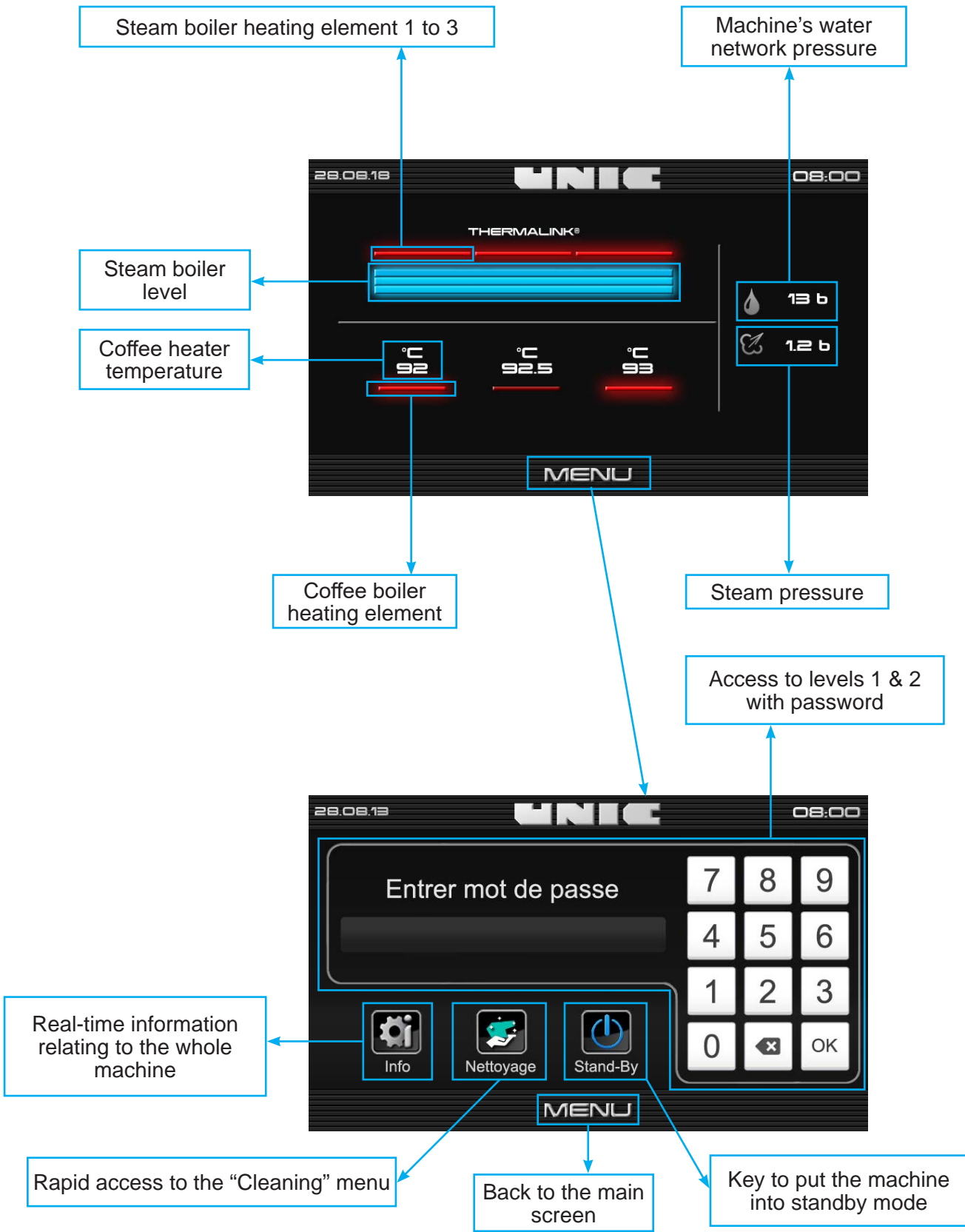

◆ Description of the Dosamat BGX menu



◆ **Description of the BTA menu**



◆ Various icons

	Icon to access the “rapid access/code” screen
	Back to the main screen
	Back to the previous page
	Icon to copy a file and/or data
	Icon to indicate parameters (e.g.: steam settings)
	Icon to save data and/or settings
	Icon to confirm data and/or settings
	Icon to cancel data and/or settings
	Icon to access enabled error codes / alarms.

► Main menu

Once the security code has been confirmed, levels 1 (Use) or 2 (Technician) are accessible.

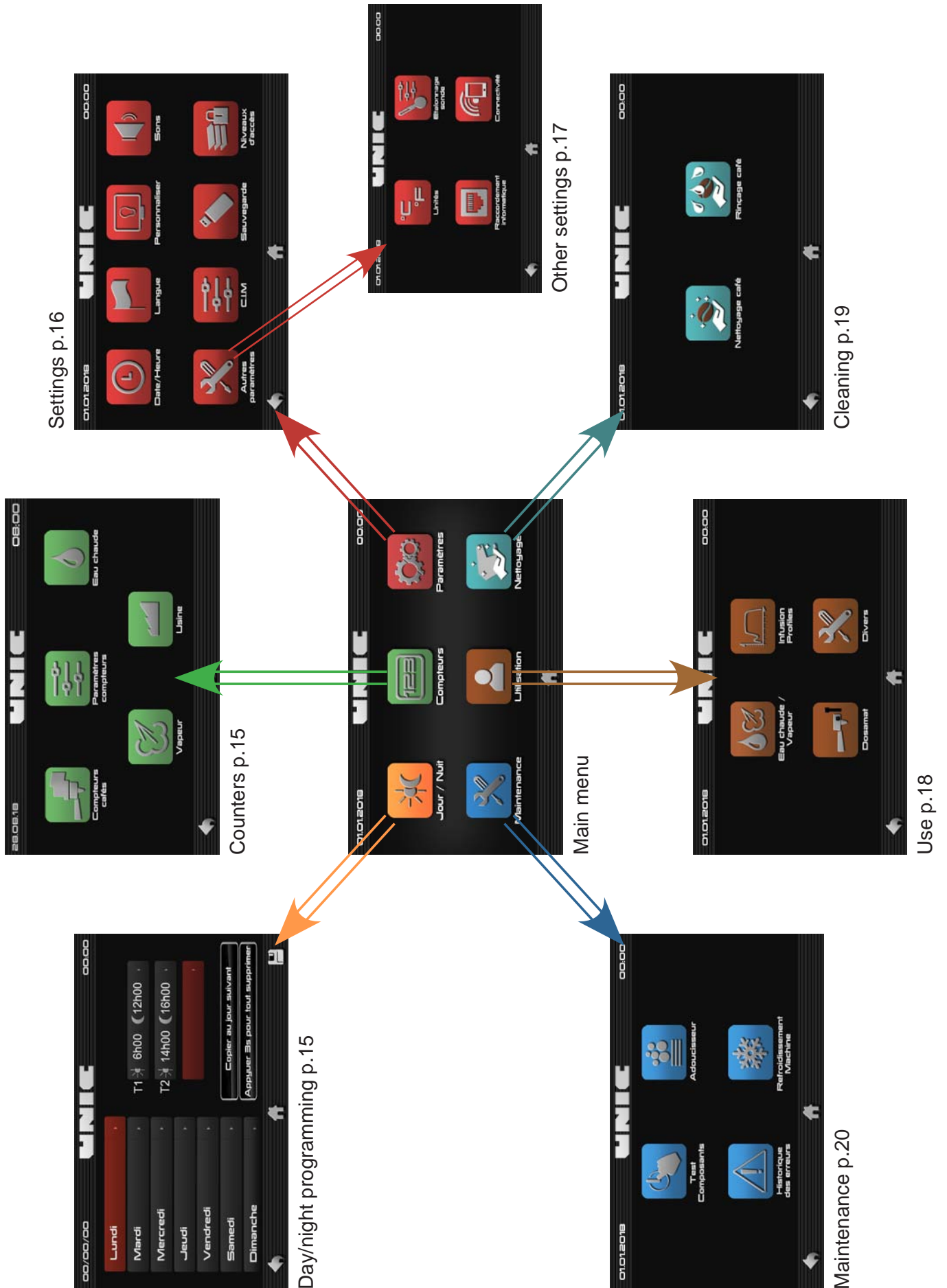

► Day/night programming

Used to programme days and hours of automatic passage in Night mode (Machine on standby, reduced heating temperatures) and Day mode, followed or not by an automatic cleaning cycle.

To add a time range:

- Press “add a time range”:
- Schedule the required times
- Do not forget to validate
- Then you can either copy this time range the next day or add a new time range.



If you want to re-schedule your time ranges, press 3 seconds on the button on the bottom right of the screen.

Do not forget to save your settings.

Note: When monitoring is enabled to regulate the coffee boilers to 70°C and 0.1 bar for the steam boiler. All the screens are off, all safety mechanisms remain enabled.

Leaving standby mode: Resumption of normal settings is done 10 minutes before leaving standby mode.

► Counters

This machine is used to display statistics of all products delivered on the machine.

Note: On the USB, it is possible to do a general reset of all counters.



► Settings

This menu is used to define settings of the machine such as the date and time using the required language, the Machine Identity Card (CIM), the screensaver or temperature units.

Note: Some parameters are only accessible or modifiable on the USB.



Language p.21



Customisation p.21

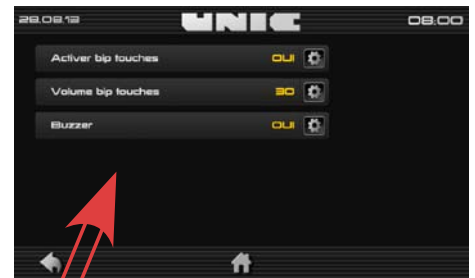

USB level required, Access levels p:22



CIM p:21, USB level required



Saving p:22

► Other settings

Probe calibration p.23

Level 2 (technician) required

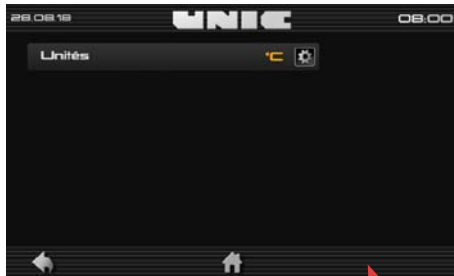

IT connection p.23

Level 2 (technician) required



Connectivity p.23

Level 2 (technician) required

► Use

Hot water / Steam p.24



Infusion profiles p.25



Dosamat p.24



Miscellaneous p.24



► Cleaning

Coffee cleaning p.28



Coffee rinsing p.28



► Maintenance

Note: accessible or modifiable at the USB level.

Components test p.30



Machine cooling p.31



Error log p.31



Softener p.30

► Details of settings menu

◆ Language

◆ Choice of language

To change the language of the machine, just press the required language icon, no need to confirm, it is instantly changed (automatically returns to the home menu).

◆ Customisation

It is possible to change the screensaver and the type of virtual keyboard.

◆ Choice of type of keyboard

In this sub-menu, it is possible to change the type of virtual keyboard. There are two modes: AZERTY or QWERTY (no need to confirm, the change is done once the type is selected).

◆ Screensaver

Once “machine image” is pressed, you have a choice between several standard screensavers. Just press the required image (the images scroll through), the cursor is used to adjust the standby time of the screensaver (cursor to the left = disabled standby).

You can import personal screensavers:

To do this, insert the USB flash drive containing the images, press the “import...” tab, select the image(s) then validate.

Procedure (add images to the USB flash drive from a computer):
Open the USB flash drive > open the “UNIC” file > open the “F_ECRAN” folder > copy the image in this folder > follow the instructions in the “screensaver” menu

If, on the USB flash drive, there is no “F_ECRAN” folder, create a new folder directly in the “UNIC” directory, while precisely following the syntax.

If the syntax is not precise, or if the “F_ECRAN” is a sub-folder of a folder other than “UNIC”, the machine will be incapable of finding your logo.

Note: Accepted formats .png .jpg, resolution 800x480.

The name of the file must not have any accents or spaces.

◆ CIM

Note: Technician level required for modifications.

Used to access and/or change the machine’s features, such as unit settings (dosamat or 2 cups), pre-infusion or offset, temperature, etc.



Général		Détails
Propriété		
Valeur		
Images		
ID de l'image		
Dimensions	800 x 480	
Largeur	800 pixels	
Hauteur	480 pixels	
Résolution horizontale	72 ppp	
Résolution verticale	72 ppp	

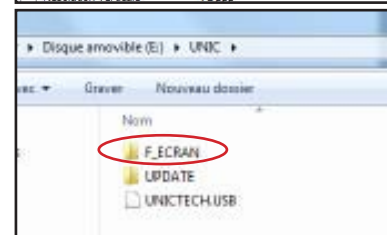

◆ Saving

This sub-menu is used to import (and/or export) for example keyboards of products already created on a similar machine. Ditto for settings or databases.

◆ Levels of access

Access to the main menu is authorised after entry of a code. This locking is prioritised into levels. Access to the “Levels of access” menu and the modification of codes is only possible when the USB flash drive is inserted.

The “user” (barista) level has access to practically all machine settings allowing the user to work comfortably. It will however be restricted for certain settings linked to maintenance (requiring intervention by a technician) and counters, monetary link settings, IoT (linked to management of the establishment).

To change a password:

Click on the access level to be modified.

Enter the password, validate.

Confirm the password, validate.



		User	Technician	USB
Main menu	START AND FINISH OF STANDBY	YES	YES	YES
	DAY/NIGHT	YES	YES	YES
	COUNTERS (READING)	YES	YES	YES
	COUNTERS (SETTINGS AND RESETTING)	NO	NO	YES
	SETTINGS	YES	YES	YES
	MAINTENANCE	NO	YES	YES
	USE	YES	YES	YES
	CLEANING	YES	YES	YES
Exceptions in Settings	CIM	NO	YES	YES
	LEVELS OF ACCESS	NO	NO	YES
	IT CONNECTION	NO	YES	YES
	IOT CONNECTIVITY	NO	YES	YES
	PROBE CALIBRATION	NO	YES	YES
CODES BY DEFAULT		1234	6789	

► Details of Other settings menu

◆ Probe calibration

Used to perfectly measure and adjust the value of the coffee probe temperature, regulate the probe's offset to adjust the temperature.

Note: *level 2 (technician) required*

◆ IT connection

Protocol type: EXE / MDB

Allows you to choose the type of IT connection:

- Credit / Debit
- Debit / Credit
- RS 232

◆ Connectivity

1st stage: go to settings > CIM > serial number, configure the machine's serial number (S/N)

The S/N is used to identify the machine on the UNIC IOT interface. It is fixed and unique.

2nd stage: go to other settings > Connectivity

Type of connection

- GSM (no settings needed)
- Wifi:

Security: choose the security with respect to your wifi network:
WEP / WPA / WPA2

SSID: name of the wifi connection (name of point of access, router, box)

Password: the wifi access point word

Very important, perfectly comply with the syntax: lower case upper case characters

Diagnostic:

1. Switch the machine off then on again.
2. Wait a few minutes. The LED turns green if the internet connection is OK.

Green LED = connection ok with Server

Orange LED = no connection with Server

Red LED = communication problem with machine



► Details of Use menu

◆ Hot water & steam

Large steam (option)	0 to 100	dry
Small steam (option)	0 to 100	dry
steamAir temperature (option)	50 to 90	°C
Large volume of hot water	0 to 1,000	cc
Small volume of hot water	0 to 1,000	cc
Steam pressure	0.7 to 1.4	bar

To adjust overheating of steam (optional), go to “dry steam”, adjust the required temperature using the arrows. Do not forget to validate with the right-hand key.



◆ Dosamat

Self-time adjustment = Definition of the timing allows you to arrange the cups before the cycle automatically starts.
Default start = small dose / large dose / last dose.



◆ Infusion profiles

Groups together all the adjustments of the machine linked to coffee extraction.

The Manager profile consists of 2 quite distinct parts:

- Standard mode
- Expert mode

Access to standard mode settings

Access to expert mode settings



Tick the boxes to allocate either standard mode or one or several possible expert mode(s) per unit.

◆ Standard mode

Standard mode corresponds to the menu of Stella di Caffè comprising:

Coffee dose adjustments

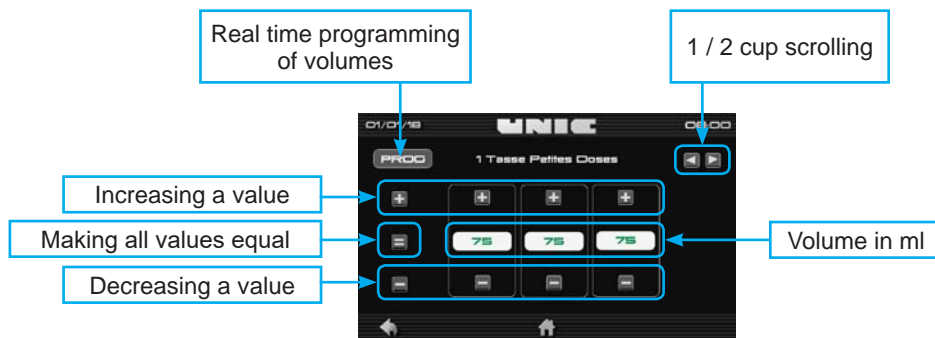

Pre-infusion setting

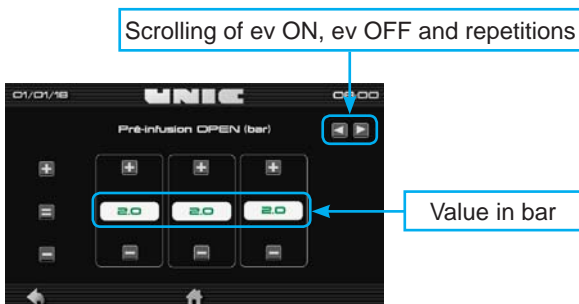

Temperature setting of units

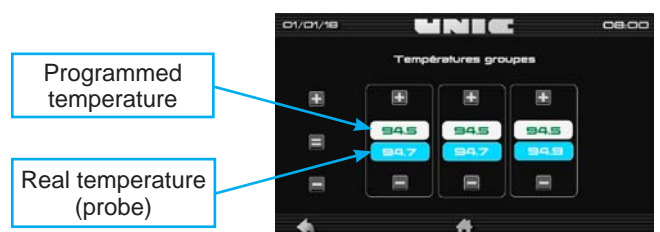

◆ Expert mode

The **Expert** mode corresponds to a completely independent menu incompatible with the Standard mode. I.e. It has its own temperature, dose, pre-infusion and post-infusion settings with possibilities of much more advanced settings.

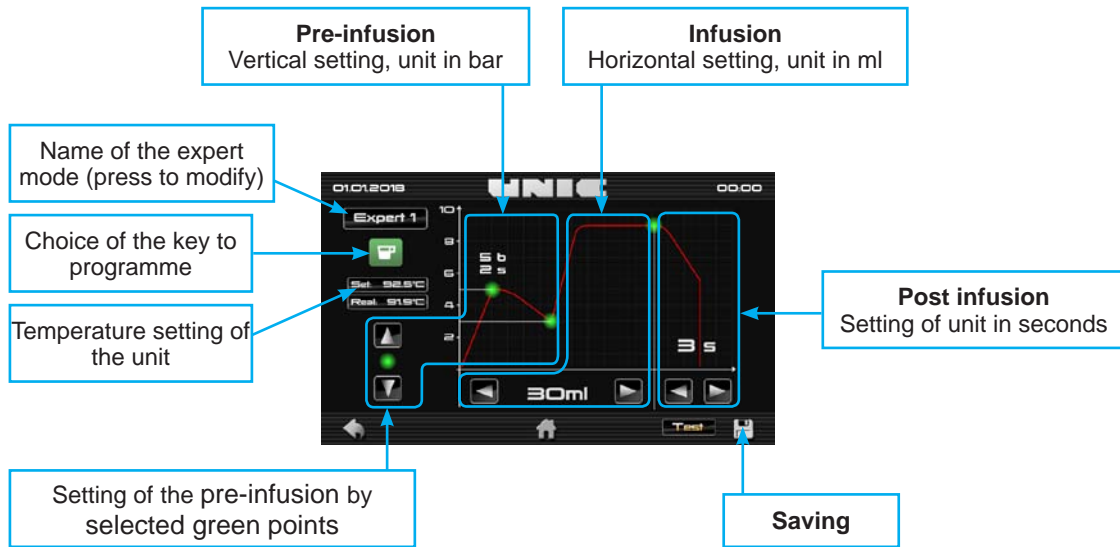

BGX

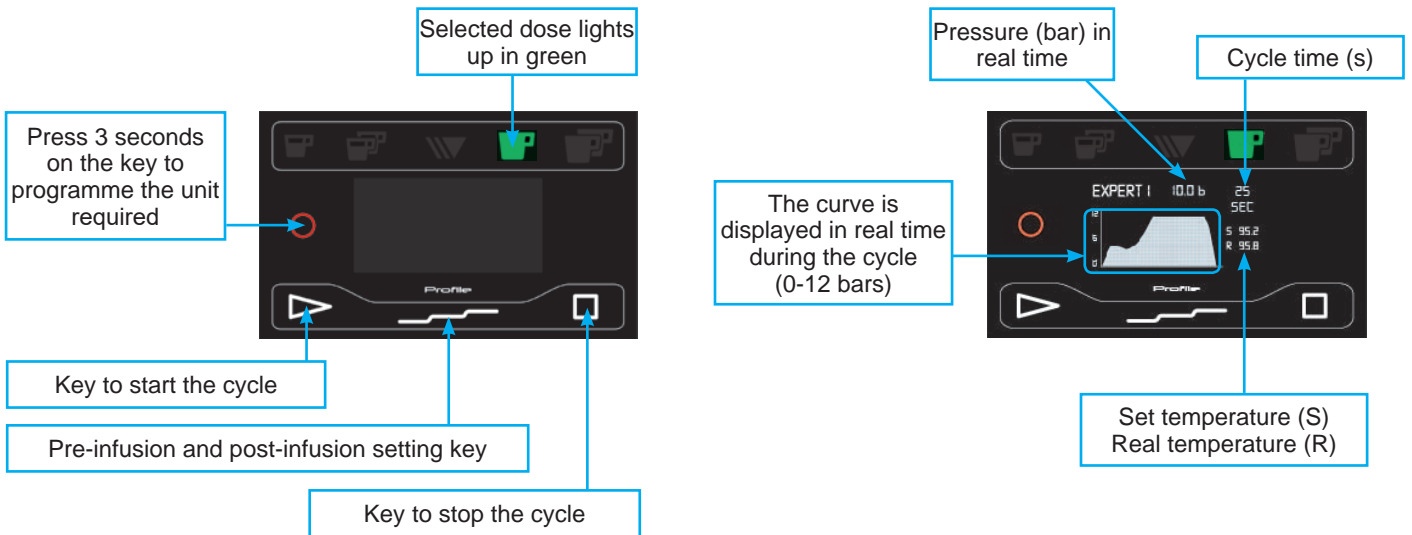

The expert mode interacts with BGXs and is broken down into 3 important stages:

- The choice of allocation in the table
- Display / edit in the curve
- Save a curve

1st stage,
choice of profiles required per unit.

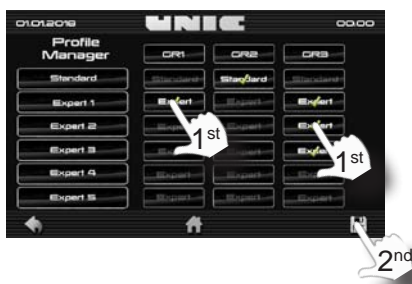

2nd stage,
programming of different profiles.

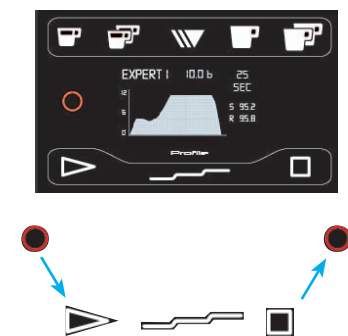

3rd stage,
Setting and recording of the profile.

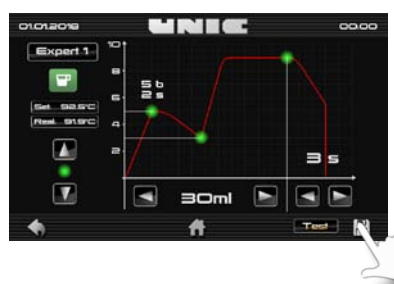

Setting procedure of a dose in expert mode,
Example 1 small dose cup:

1 Choose the expert mode to be modified

2 Press the key to modify the required volume (on the BGX, the corresponding key is green)

3 Press 3 seconds on the key to enter in programming

4 Press 3 seconds on the key to start the cycle

5 Press the key for pre-infusion (EVP=OFF)

6 Press the key for pre-infusion (EVP=ON)

7 Press the key for post-infusion (EVP=OFF)

8 Press the the key to stop the cycle. If the key is unsatisfactory, resume at stage 4

9 To save the cycle, press 3 seconds on the key

10 Possibility of adjusting the infusion curve after the cycle has been completed (on the BTA) Do not forget to save

🏠 MAINTENANCE & REPAIRS

▶ Cleaning

- REMEMBER TO REGENERATE THE WATER TREATMENT SYSTEM PERIODICALLY.
- DO NOT USE ABRASIVE CLEANERS OR SCOURING PADS. DO NOT USE CLEANERS CONTAINING BLEACH OR COFFEE DETERGENT.
- THE MACHINE SHOULD BE DESCALED ONLY BY A QUALIFIED TECHNICIAN.

◆ After each use

◆ Steam outlet tube

After each use, clean the steam outlet with a damp cloth and release steam for a short time to eliminate the small residue of milk that may have built up in the tube.
(Remove the tip of the steam pipe for easier cleaning).

◆ Daily

◆ Before use or after several hours of inactivity:

Drain:

- for each unit and water outlet, 0.5 litre of water.
- for each steam outlet, steam for 1 minute.

“BEFORE PREPARING A DRINK”

◆ After the service

- Take the 2-cup filter holder cup.
- Place the rubber plug (Ref. [DO-197](#)) inside the filter.

Rinse the decompression circuit:

- Engage the cup onto the unit by tightening it.
- Press a coffee key to pressurise the cup, and then stop the unit. Repeat the operation several times by emptying the water contained in the cup each time.

Rinsing of the cup seal:

- Engage the cup onto the unit without tightening it.
- Press a coffee key by tightening and loosening the cup alternately, to create a leak at the level of the seal.

◆ Weekly

◆ Filter holder cup

Clean the filter holder cups and filters (by removing the filter from the cup) with detergent.

◆ Basin

Remove the basin - top of basin assembly, and clean each component in your sink.

◆ Bodywork

Use a soft cloth and alcohol for the parts in stainless steel, and non-abrasive detergent for the painted parts.

► Details of the coffee cleaning Procedure menu

◆ Coffee rinsing

In the “Cleaning” menu, the rinsing icon starts a 15 second rinse on the selected unit.

As indicated on the screen, press any key (blue) of the keyboard (BGX) to start rinsing.

To return to the main menu, press the “home” icon.

◆ Coffee cleaning



◆ Reference of cleaning products

UNIC Reference Puly caff: 92040

UNIC Reference plug: DO-197

Note: for more information on cleaning products, refer to the manufacturer’s safety data sheet.

By pressing the “coffee cleaning” icon, you access the procedure. Follow it step by step on the machine screen as indicated below.

One or several units can be selected



1

The keys of the units turn blue.



2

Cleaning starts when you press a blue key of each unit.



3

At the end of 15 cycles, remove the plugs and start the rinse.



4

When rinsing, handle the cup as indicated.



5



6

Cleaning details:

15 cycles (8 seconds ON / 12 seconds OFF) > cleaning
1 45 seconds cycle ON > rinsing

◆ option SteamAir

The **steamAir**  option, when making cappuccino, is used to transform milk into cream in a simple, automatic operation: the (adjustable) air/steam mixture brings milk to the programmed temperature, 60° to 70° (140°F to 158°F) while emulsifying it.

It stops automatically when the temperature is reached which saves the milk from boiling.

When the air/steam adjustment is defined, the operation is as follows:

Insert the **steamAir** outlet into the milk container.

- Press the **steamAir** key.
- Wait for it to stop automatically.

The **steamAir** box also controls a timed steam and hot water outlet.

◆ Components

Cleaning of the outlet:

- Remove and clean the outlet at least once a day.
- After each use, rinse the outlet with a burst of steam.

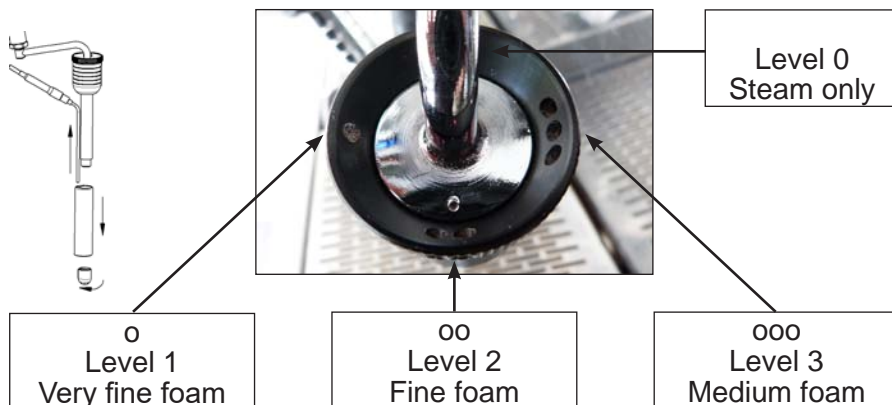

◆ key SteamAir

- Automatic mode: (to reach the programmed T°)

One press on the key makes the SteamAir flow until the liquid reaches the pre-set temperature (see programming §).

Stop the operation manually by pushing the key again.

- Manual mode: (over the programmed T°)

If, once stopped in automatic mode (temperature reached), you wish to continue to heat, you must press the key again.

It then switches to manual mode and the steam outlet will be enabled again.

It is stopped when the key is pressed one more time.

If you do not do it manually, it will be stopped automatically by one of the two safety mechanisms: after 180 seconds or when the liquid temperature reaches 96°

◆ Programming

Setting of the **SteamAir** temperature is done from the “use > hot water/steam” menu (see page 24).

Note: The temperature adjustment can be done within a range of 50°C to 90°C (122°F 194°F), the recommended adjustment is 62°C (143.6°F).

► Details of the Maintenance menu

◆ Components test

When you enter the menu, the machine goes into “test” mode, heating of the units and steam is disabled.

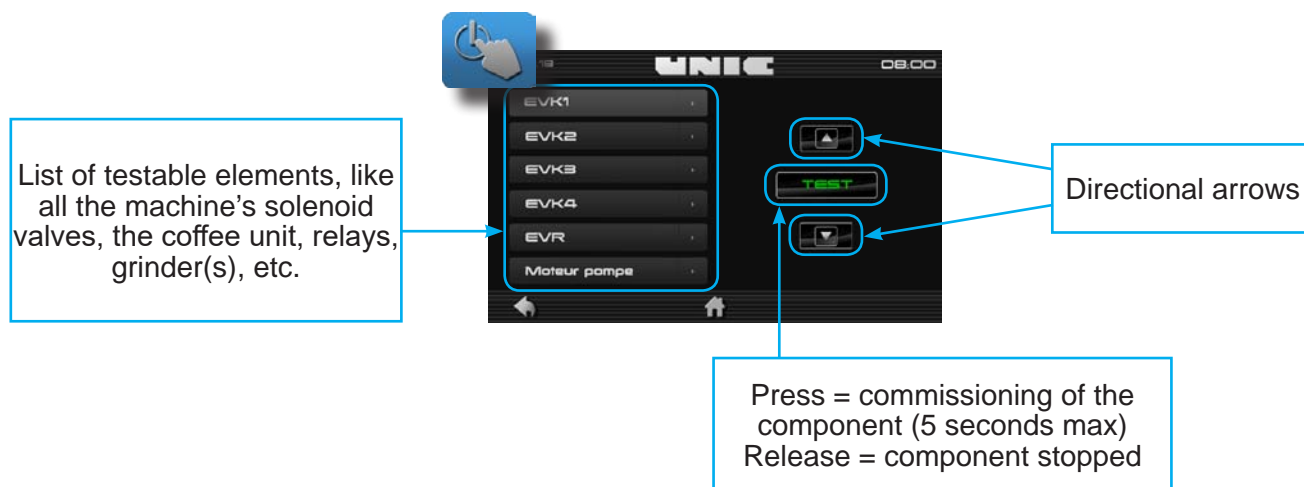

EVK1	Unit 1 coffee EV	DO2	Unit 2 volume dosing
EVK2	Unit 2 coffee EV	DO3	Unit 3 volume dosing
EVK3	Unit 3 coffee EV	MPO	Pump
EVP1	Unit 1 pre-infusion EV	EVR	Filling EVR
EVP2	Unit 2 pre-infusion EV	RSV1	Steam static relay 1
EVP3	Unit 3 pre-infusion EV	RSV2	Steam static relay 2
RS1	Static relay 1	RSV3	Steam static relay 3
RS2	Static relay 2	EVV	Steam EV
RS3	Static relay 3	EVE	Hot water EV
DO1	Unit 1 volume dosing	DOE	Hot water volume dispenser

◆ Softener

Two water softener suppliers are available at UNIC SA.
BRITA®
BESTMAX™

Test the water hardness of the mains and refer to the technical documentation of the water softener used, for optimal settings.

Note: A softener must be changed every year, even if it does not reach the end of its filtering capacity.



◆ Descaling

The machine should be descaled only by a qualified technician.

◆ ***Machine cooling***

Select the boiler(s) to cool then start the steam and/or coffee cycles. Temperatures and pressure are indicated in real time on the BTA.



◆ ***Error log***

This menu has no action on the electronics of the elements affected by the machine's error codes. It is a simple log of events in which the technician can record the interventions performed. The help can be consulted for information purposes.

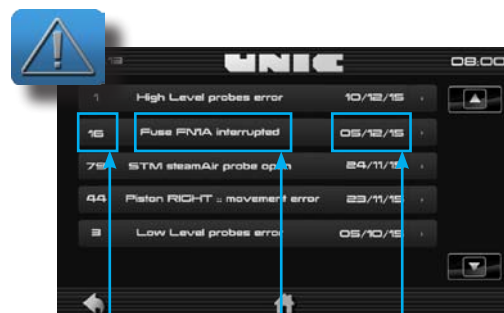

Error code number

Detailed name of the error code

Date of appearance of the error code

► Preventive maintenance

Maintenance A: every 150kg or 6 months (intervention ~30 min)				
Type	Title	Control action	Corrective action	Tools
A	Visual control	Detecting traces of leaks under the machine		
A	Software version	Switch the machine off and on, note the software version	Update to be defined	
A	Water treatment	Check the date of installation (or regeneration) of the softener : water consumption and date of installation Recommended hardness check : between 7 and 10th		
A	Pressures	Start a coffee extraction on any group and check the pressure on the pressure gauge : <ul style="list-style-type: none"> • Pump pressure : 8,5 bar ≤ PP ≤ 9,5 bar • HP valve pressure : 13 bar ≤ HPVP ≤ 15 bar • Steam pressure : 0,8 bar ≤ SP ≤ 1,3 bar 	Check PP in infusion on 1 group, the pressure will rise after infusion to the HPVP value. To modify them, proceed to the adjustment of the By-Pass and the adjustment of the HP valve.	Flat screwdriver + Tompouce BTR 2.5mm 24mm flat wrench HP valve tool (OU003)
A	Group flow	Check the flow (without coffee) on each group: Average flow for 10cl : 8 seconds ≤ DM ≤ 12 seconds	If DM is different, check the condition of the Ø0,7mm nozzle	Measuring cup (54260) Nozzle (23117)
A	Water / steam flow & filling	Check the correct water flow on the water and steam outlets (clean the lances) Check the correct filling of the service boiler	The pump pressure for filling immediately after large extraction (water + coffee on 1 group) must be ≥ 7bar => EV filling setting	Flat screwdriver + Tompouce
A	Temperatures	Check the coffee (TC) and mixed water (TMW) temperatures 80°C ≤ TC ≤ 95°C 85°C ≤ TMW ≤ 95°C	To modify TC , it is necessary to modify the vapor pressure (PROG => PRS) To modify TMW , play on the cold water EV clamping screw	Flat screwdriver + Tompouce Thermometer
A	Piston mobility / cup gasket	Check the mobility of the filter holder in infusion with coffee and without coffee: The movement is «difficult» in brewing with coffee and «easy» without coffee	If the Cup seal is worn or too hard, replace the group the gasket.	8mm pipe wrench BTR 6mm Thin and coarse flat screwdriver
A	Filter holder / Dosamat	Check the cleanliness of the filter holders Check the sensitivity of the DOSAMAT detection. Control: 1c, 2c, 0c (No filter holder) DOSAMAT finger : Visual inspection (crack) and clean	If no reaction, check prog (Dos), then connection, replacement if a finger is cracked defective (44720)	Phillips screwdriver
A	Product quality control	Do a product test with the customer	If necessary, make various adjustments for customer satisfaction.	

Maintenance A+B: every 300kg or 1 year (intervention ~70 min)

Type	Title	Control action	Corrective action	Tools
A	Visual control	Detecting traces of leaks under the machine		
A	Software version	Switch the machine off and on, note the software version	Update to be defined	
A	Water treatment	Check the date of installation (or regeneration) of the softener : water consumption and date of installation Recommended hardness check : between 7 and 10th		
A	Pressures	Start a coffee extraction on any group and check the pressure on the pressure gauge : <ul style="list-style-type: none"> Pump pressure : 8,5 bar ≤ PP ≤ 9,5 bar HP valve pressure : 13 bar ≤ HPVP ≤ 15 bar Steam pressure : 0,8 bar ≤ SP ≤ 1,3 bar 	Check PP in infusion on 1 group, the pressure will rise after infusion to the HPVP value. To modify them, proceed to the adjustment of the By-Pass and the adjustment of the HP valve.	Flat screwdriver + Tompouce BTR 2.5mm 24mm flat wrench HP valve tool (OU003)
A	Group flow	Check the flow (without coffee) on each group: Average flow for 10cl : 8 seconds ≤ DM ≤ 12 seconds	If DM is different, check the condition of the Ø0,7mm nozzle	Measuring cup (54260) Nozzle (23117)
A	Temperatures	Check the coffee (TC) and mixed water (TMW) temperatures 80°C ≤ TC ≤ 95°C 85°C ≤ TMW ≤ 95°C	To modify TC , it is necessary to modify the vapor pressure (PROG => PRS) To modify TMW , play on the cold water EV clamping screw	Flat screwdriver + Tompouce Thermometer
A	Piston mobility / cup gasket	Check the mobility of the filter holder in infusion with coffee and without coffee: The movement is «difficult» in brewing with coffee and «easy» without coffee	If the Cup seal is worn or too hard, replace the group the gasket.	8mm pipe wrench BTR 6mm Thin and coarse flat screwdriver
A	Filter holder / Dosamat	Check the cleanliness of the filter holders Check the sensitivity of the DOSAMAT detection. Control: 1c, 2c, 0c (No filter holder) DOSAMAT finger : Visual inspection (crack) and clean	If no reaction, check prog (Dos), then connection, replacement if a finger is cracked defective (44720)	Phillips screwdriver
B	BP valve (low pressure)	Check the valve by pulling the loop (Beware of burns with steam)		Flat screwdriver
B	Hydraulic fittings	Visually check the general condition of the hydraulic connections		
B	Drain	Check that the drain runs smoothly		
B	Steam outlets / Hot water	Check the steam and hot water outlets : Disassembly and cleaning if needed		Flat wrench 21mm
Machine COOLING, POWER OFF and WATER SHUTDOWN				
B	Nozzles	Disassembly the group skirt, disconnection, disassembly and cleaning of grids and replacement of group nozzles.		Flat screwdriver 21mm pipe wrench Swab
B	Electrical connections	Tighten all electrical connections to the terminal block		Flat screwdriver
A	Water / steam flow & filling	Check the correct water flow on the water and steam outlets (clean the lances) Check the correct filling of the service boiler	The pump pressure for filling immediately after large extraction (water + coffee on 1 group) must be ≥ 7bar => EV filling setting	Flat screwdriver + Tompouce
A	Product quality control	Do a product test with the customer	If necessary, make various adjustments for customer satisfaction.	

Maintenance A+B+C: every 800kg or 2 years (intervention ~90 min)

Type	Title	Control action	Corrective action	Tools
A	Visual control	Detecting traces of leaks under the machine		
A	Software version	Switch the machine off and on, note the software version	Update to be defined	
A	Water treatment	Check the date of installation (or regeneration) of the softener : water consumption and date of installation Recommended hardness check : between 7 and 10th		
A	Pressures	Start a coffee extraction on any group and check the pressure on the pressure gauge : <ul style="list-style-type: none"> Pump pressure : 8,5 bar ≤ PP ≤ 9,5 bar HP valve pressure : 13 bar ≤ HPVP ≤ 15 bar Steam pressure : 0,8 bar ≤ SP ≤ 1,3 bar 	Check PP in infusion on 1 group, the pressure will rise after infusion to the HPVP value. To modify them, proceed to the adjustment of the By-Pass and the adjustment of the HP valve.	Flat screwdriver + Tompouce BTR 2.5mm 24mm flat wrench HP valve tool (OU003)
A	Temperatures	Check the coffee (TC) and mixed water (TMW) temperatures 80°C ≤ TC ≤ 95°C 85°C ≤ TMW ≤ 95°C	To modify TC , it is necessary to modify the vapor pressure (PROG => PRS) To modify TMW , play on the cold water EV clamping screw	Flat screwdriver + Tompouce Thermometer
B	BP valve (low pressure)	Check the valve by pulling the loop (Beware of burns with steam)		Flat screwdriver
B	Hydraulic fittings	Visually check the general condition of the hydraulic connections		
B	Drain	Check that the drain runs smoothly		
B	Steam outlets / Hot water	Check the steam and hot water outlets : Disassembly and cleaning if needed		Flat wrench 21mm
Machine COOLING, POWER OFF and WATER SHUTDOWN				
B	Nozzles	Disassembly the group skirt, disconnection, disassembly and cleaning of grids and replacement of group nozzles.		Flat screwdriver 21mm pipe wrench Swab
C	Cup seals / Piston seals	Disassemble the lower part of the group, clean the elements and replace: cup seal, O-rings and piston spring «		Silicone grease (PC42) Thin and coarse flat screwdriver 8mm pipe wrench BTR 6mm
C	Level probes	Disassemble and clean the level probe		flat screwdriver 17mm flat wrench 10mm flat wrench
A	Water / steam flow & filling	Check the correct water flow on the water and steam outlets (clean the lances) Check the correct filling of the service boiler	The pump pressure for filling immediately after large extraction (water + coffee on 1 group) must be ≥ 7bar => EV filling setting	Flat screwdriver + Tompouce
A	Piston mobility / cup gasket	Check the mobility of the filter holder in infusion with coffee and without coffee: The movement is «difficult» in brewing with coffee and «easy» without coffee	If the Cup seal is worn or too hard, replace the group the gasket.	8mm pipe wrench BTR 6mm Thin and coarse flat screwdriver
A	Group flow	Check the flow (without coffee) on each group: Average flow for 10cl : 8 seconds ≤ DM ≤ 12 seconds	If DM is different, check the condition of the Ø0,7mm nozzle	Measuring cup (54260) Nozzle (23117)

A	Filter holder / Dosamat	Check the cleanliness of the filter holders Check the sensitivity of the DOSAMAT detection. Control: 1c, 2c, 0c (No filter holder) DOSAMAT finger : Visual inspection (crack) and clean	If no reaction, check prog (Dos), then connection, replacement if a finger is cracked defective (44720)	Phillips screwdriver
A	Product quality control	Do a product test with the customer	If necessary, make various adjustments for customer satisfaction.	

Maintenance A+B+C+D: every 2000kg or 4 years (intervention ~130 min)

Type	Title	Control action	Corrective action	Tools
A	Visual control	Detecting traces of leaks under the machine		
A	Software version	Switch the machine off and on, note the software version	Update to be defined	
A	Water treatment	Check the date of installation (or regeneration) of the softener : water consumption and date of installation Recommended hardness check : between 7 and 10th		
A	Temperatures	Check the coffee (TC) and mixed water (TMW) temperatures 80°C ≤ TC ≤ 95°C 85°C ≤ TMW ≤ 95°C	To modify TC , it is necessary to modify the vapor pressure (PROG => PRS) To modify TMW , play on the cold water EV clamping screw	Flat screwdriver + Tompouce Thermometer
B	BP valve (low pressure)	Check the valve by pulling the loop (Beware of burns with steam)		Flat screwdriver
B	Hydraulic fittings	Visually check the general condition of the hydraulic connections		
B	Drain	Check that the drain runs smoothly		
B	Steam outlets / Hot water	Check the steam and hot water outlets : Disassembly and cleaning if needed		Flat wrench 21mm
Machine COOLING, POWER OFF and WATER SHUTDOWN				
B	Nozzles	Disassembly the group skirt, disconnection, disassembly and cleaning of grids and replacement of group nozzles.		Flat screwdriver 21mm pipe wrench Swab
C	Cup seals / Piston seals	Disassemble the lower part of the group, clean the elements and replace: cup seal, O-rings and piston spring «		Silicone grease (PC42) Thin and coarse flat screwdriver 8mm pipe wrench BTR 6mm
D	Coffee EV	Replace Coffee EV		Phillips screwdriver BTR 3mm r
C	Level probes	Disassemble and clean the level probe		flat screwdriver 17mm flat wrench 10mm flat wrench

D	BP valve (low pressure)	Replace BP valve		Flat wrench 15mm
D	HP valve (high pressure)	Replace HP valve		24mm flat wrench HP valve tool (OU003) Detergent
D	Pump 200 L/h	Replace the pump		8mm flat wrench Flat screwdriver + Tompouce 21mm flat wrench Fluoride grease
A	Pressures	Start a coffee extraction on any group and check the pressure on the pressure gauge : <ul style="list-style-type: none"> Pump pressure : 8,5 bar ≤ PP ≤ 9,5 bar HP valve pressure : 13 bar ≤ HPVP ≤ 15 bar Steam pressure : 0,8 bar ≤ SP ≤ 1,3 bar 	Check PP in infusion on 1 group, the pressure will rise after infusion to the HPVP value. To modify them, proceed to the adjustment of the By-Pass and the adjustment of the HP valve.	Flat screwdriver + Tompouce BTR 2.5mm 24mm flat wrench HP valve tool (OU003)
A	Water / steam flow & filling	Check the correct water flow on the water and steam outlets (clean the lances) Check the correct filling of the service boiler	The pump pressure for filling immediately after large extraction (water + coffee on 1 group) must be ≥ 7bar => EV filling setting	Flat screwdriver + Tompouce
A	Piston mobility / cup gasket	Check the mobility of the filter holder in infusion with coffee and without coffee: The movement is «difficult» in brewing with coffee and «easy» without coffee	If the Cup seal is worn or too hard, replace the group the gasket.	8mm pipe wrench BTR 6mm Thin and coarse flat screwdriver
A	Group flow	Check the flow (without coffee) on each group: Average flow for 10cl : 8 seconds ≤ DM ≤ 12 seconds	If DM is different, check the condition of the Ø0,7mm nozzle	Measuring cup (54260) Nozzle (23117)

► Repairs

◆ Troubleshooting

VERY IMPORTANT!

BEFORE TAKING ANY ACTION, MAKE SURE ALL SETTINGS ARE CORRECT.

- TEMPERATURE 120°C (248°F).

STEAM PRESSURE: 0.9 to 1 bar (0.09 MPa to 0.1 MPa).

- INFUSION PRESSURE: 9 to 10 bar (0.9 MPa to 1 MPa).

The HP valve opens for a value greater than 13 bar (1.3 MPa).

- SUPPLY PRESSURE: 1 to 8 bar (0.1 MPa to 0.8 MPa).

If the machine sucks water from a tank, check the level of the tank and the state of cleanliness of the strainer foot valve if it is installed

- PRECAUTIONS TO BE TAKEN

A. Switch off the machine before any work on the electrical circuits.

B. Cool the machine and lower the pressure before any work on the hydraulic circuit.

◆ Technical features

DIMENSIONS	EPIC 2	EPIC 3	SETTINGS	
Width	79 cm / 31"	98 cm / 38.5"	Temperature	118 to 120°C 244 to 248°F
Height	51.3 cm / 20.2"	51.3 cm / 20.2"	Steam pressure	0.9 to 1 bar 0.09 to 0.1 MPa
Depth	68.2 cm / 26.8"	68.2 cm / 26.8"	Pump pressure	9 to 10 bar 0.9 MPa to 1 MPa
WEIGHT	90 kg / 198 Lb	100 kg / 220.4 Lb	HP valve	13 bar / 1.3 MPa
POWER			BP valve	3.2 bar / 0.3 MPa
230V single phase - 400V 3-phase		6,700 W	Dose of ground coffee	7 g
240V single phase - 415V 3-phase		7,700 W	Water dose	5 to 7 cl
200V 3-phase		5,400 W	Infusion time	20 to 25 seconds
230V 3-phase		6,700 W		
240V 3-phase		7,700 W		

◆ CPU connectors & fuses

SW1-1 ON	Demo mode
SW1-2 ON	Factory settings

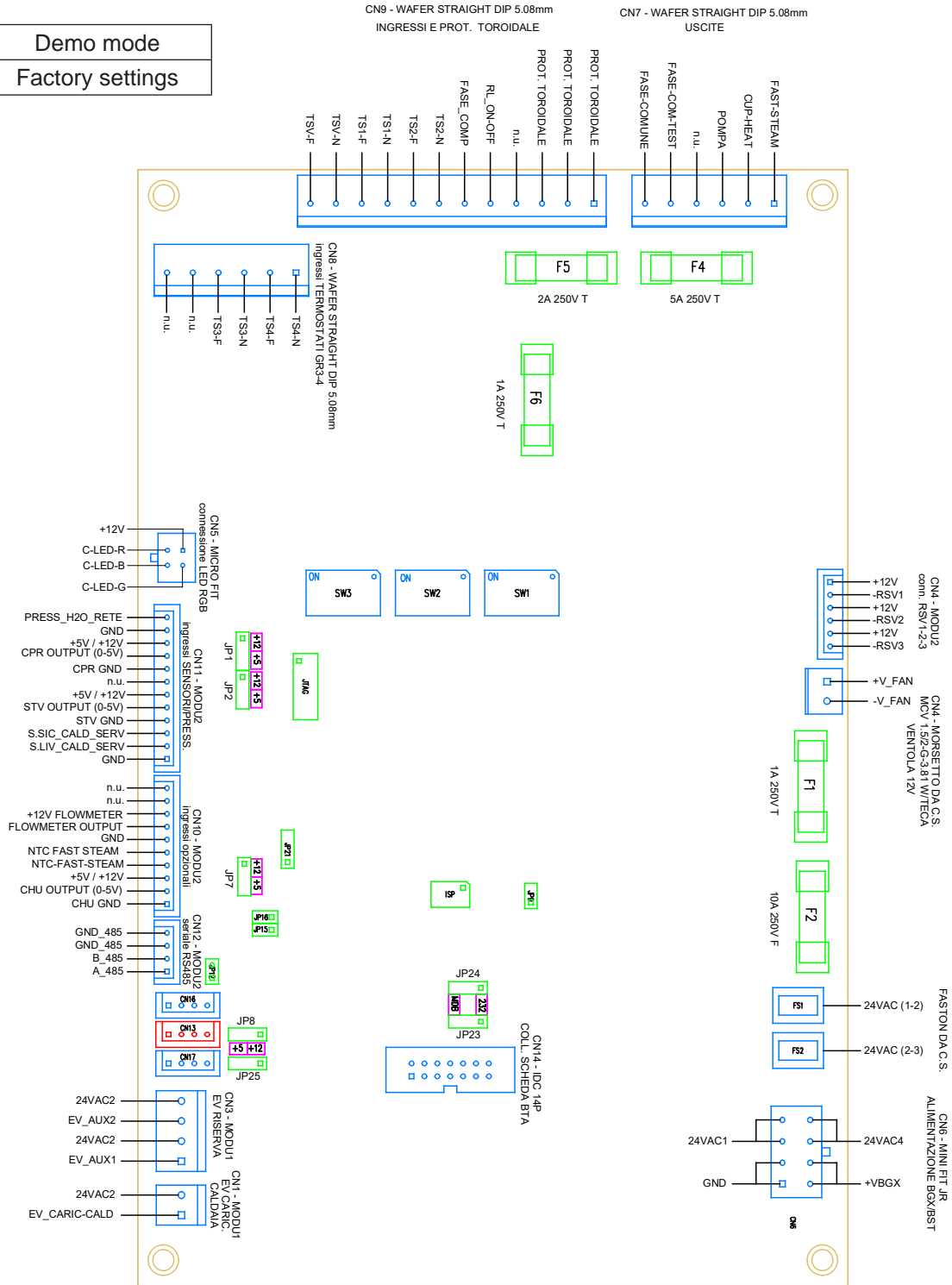

F1	T1AL 250V	EV AUX1, EV AUX2, EVR
F2	F10AL 250V	CPU Voltage, unit EV
F4	T5AL 250V	Pump, cup warmer, superheated steam
F5	T2AL 250V	(CN9) transformer, terminal, switch, unit safety thermostats.
F6	T1AL 250V	ON/OFF main switch.

JP1	CPR power supply
JP2	STV power supply
JP7	CHU power supply
JP8	CD/DC power supply
JP23	232/MODBUS selection
JP25	IOT power supply

◆ **Cable lists**

REF	DESIGNATION FR	DESIGNATION EN	C.N.	PIN	DESIGNATION PIN
FR8028	CABLE ALIMENTATION MACHINE	MACHINE POWER WIRE			
FR8031	CABLE ALIM MONO 220V UL/CSA	220V UL/CSA MACHINE POWER WIRE			
NZ8004	CABLE LIAISON 485 CPU/BGX	LINK 485 CPU/BGX CABLE	CN12	4	
NZ8005	CABLE LIAISON 485 BGX/BGX	LINK 485 BGX/BGX CABLE		4	
NZ8006	CABLE LIAISON CPU/BTA	LINK CPU/BTA CABLE		14	
NZ8007	CABLE DOSAMAT	DOSAMAT CABLE	CN4	4	
NZ8011MP	CAPTEUR CHAUDIERE VAPEUR	STEAM BOILER SENSOR CABLE	CN11	1	TERRE / MASSE
				2/3	SONDE NIVEAU CHAUDIERE
				4/5/6	CAPTEUR PRESSION CHAUDIERE VAPEUR
				8/9/10	CAPTEUR PRESSION ENTREE D'EAU
NZ8020	CMD RELAIS STATIQUE VAPEUR	STEAM SOLID STATE RELAY CABLE	CN4	1/2	RELAIS STATIQUE 3
				3/4	RELAIS STATIQUE 2
				5/6	RELAIS STATIQUE 1
NZ8022	CABLE EV REMPLISSAGE 2GR	2 UNITS EV FEEDING CABLE	CN1	1/2	EVR
NZ8023	CABLE EV REMPLISSAGE 3GR	3 UNITS EV FEEDING CABLE			
NZ8038	CABLE CN9 CPU	CN9 CPU CABLE	CN9	1	TRANSFO
				2/6	BORNIER
				3/5	CONTACTEUR
				7/8	TS2
				9/10	TS1
				11/12	TSV
NZ8039	CABLE CN8 CPU 3GR	3 UNITS CN8 CPU CABLE	CN8	3/4	TS3
NZ8042	CABLE ALIM MONO 240V 50HZ	240V 50HZ MACHINE POWER WIRE			
NZ8053	CABLE POUR LED GROUPE- EV	UNIT-EV CABLE FOR LED			
NZ8054	CABLE LED GROUPE	LED UNIT CABLE			
SE8000	CABLE BGX	BGX WIRE	CN11	1/9	EVP
				2/10	EVK
				3/10/11	DOGX
				4/5/13	CAPTEUR PRESSION GROUPE
				6/14	SONDE TEMPERATURE GROUPE
				8/16	RELAIS STATIQUE
SE8001	CABLE BST	BST WIRE		1/7	EV STEAM
				2/8	EV EAU
				3/9/10	DOE
				5/11	SONDE STEAMAIR
SE8002	CABLE COMMANDE POMPE 2GR	2 UNITS PUMP CONTROL WIRE	CN7	3/6	ALIMENTATION POMPE
SE8003	CABLE COMMANDE POMPE 3GR	3 UNITS PUMP CONTROL WIRE			
SE8006	CABLE ALIM CPU-BGX 24V AC/DC	CPU-BGX 24V AC/DC ALIM WIRE		8	
SE8007	CABLE ALIM BGX-BGX 24V AC/DC	BGX-BGX 24V AC/DC ALIM WIRE		8	
SE8008	CABLE GND CALANDRE	FRONT PANEL GND WIRE		1	
TG8012	CABLE LIAISON USB	USB LINK WIRE	CN2	4	USB

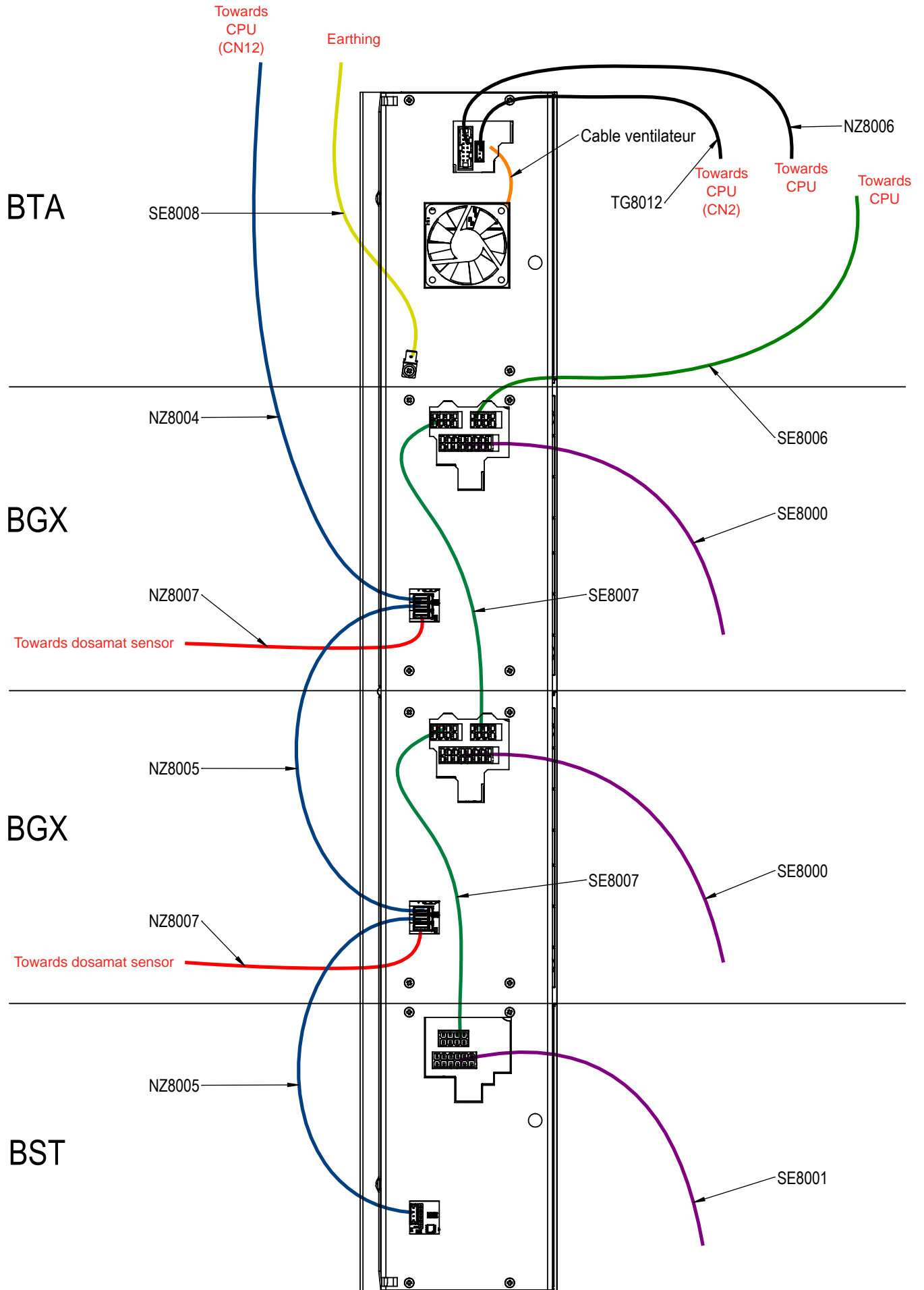

◆ **Plate assembly**

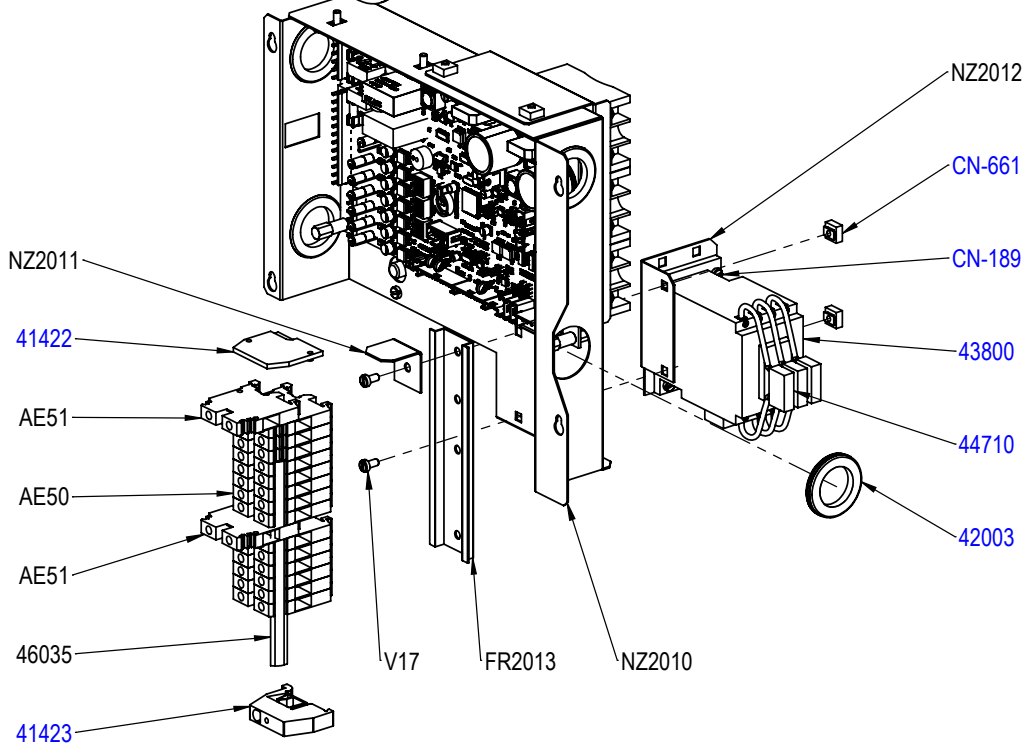
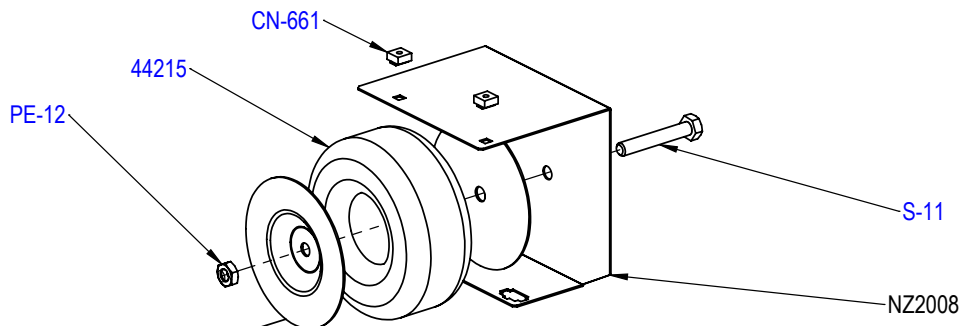
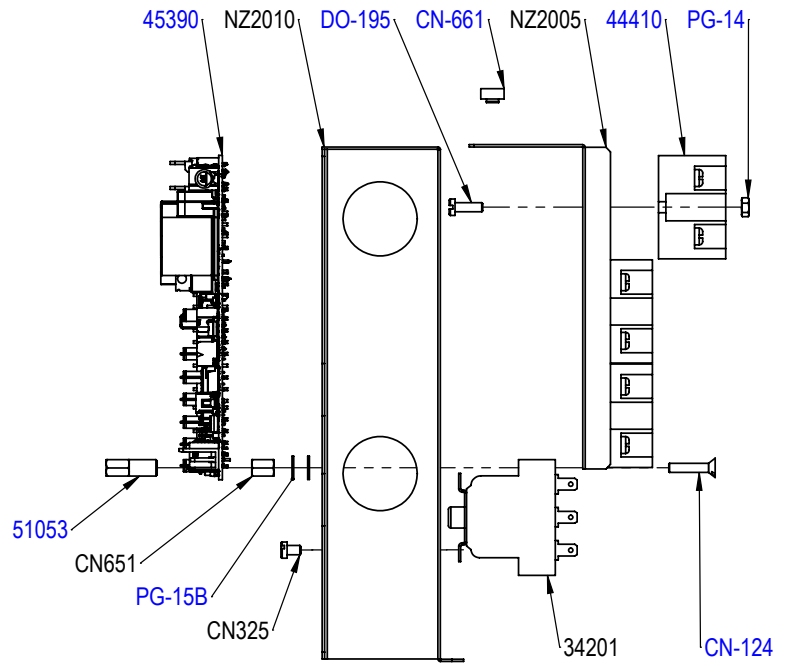
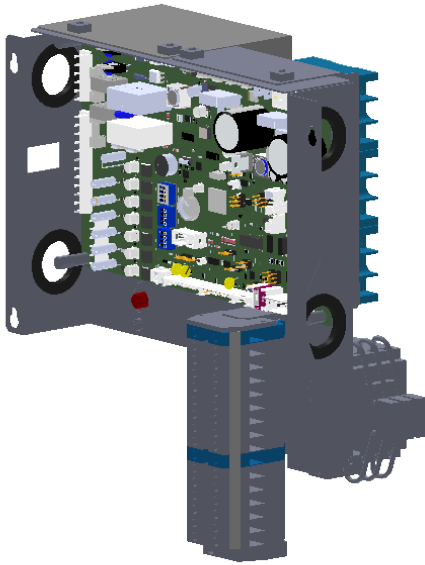

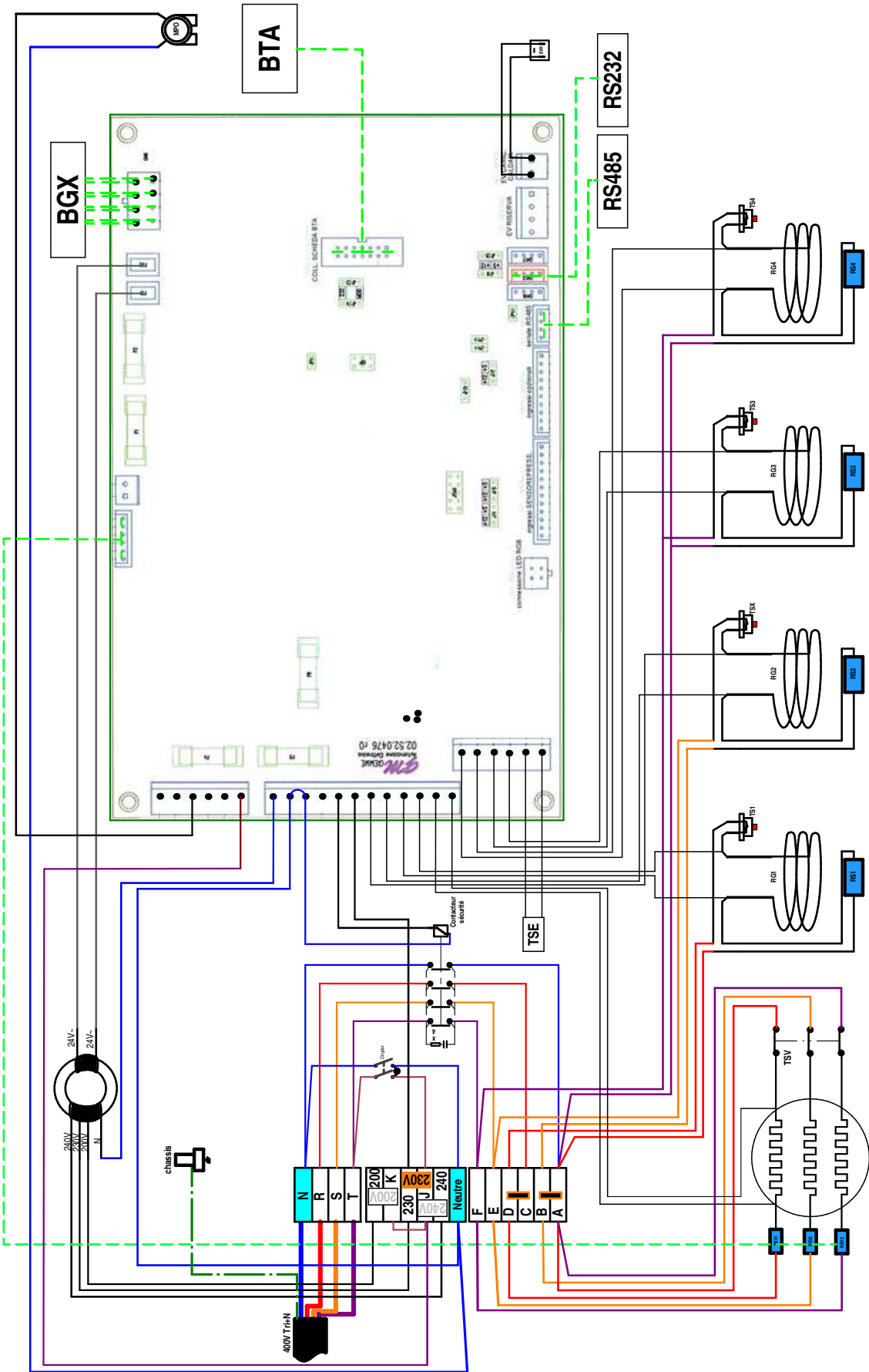

STELLA EPIC SCHEMA DE CABLAGE DE PRINCIPE 400V TRI 09/07/2018

◆ Procedure for updating the machine

Note: Leave the USB flash drive in its housing throughout the update procedure.

Insert the USB flash drive, you have several possibilities, update of the CPU, BTA or BGX update.



STAGE 1: introduce the updated USB flash drive. BTA update.



STAGE 2: CPU update

The procedure starts automatically with validation.

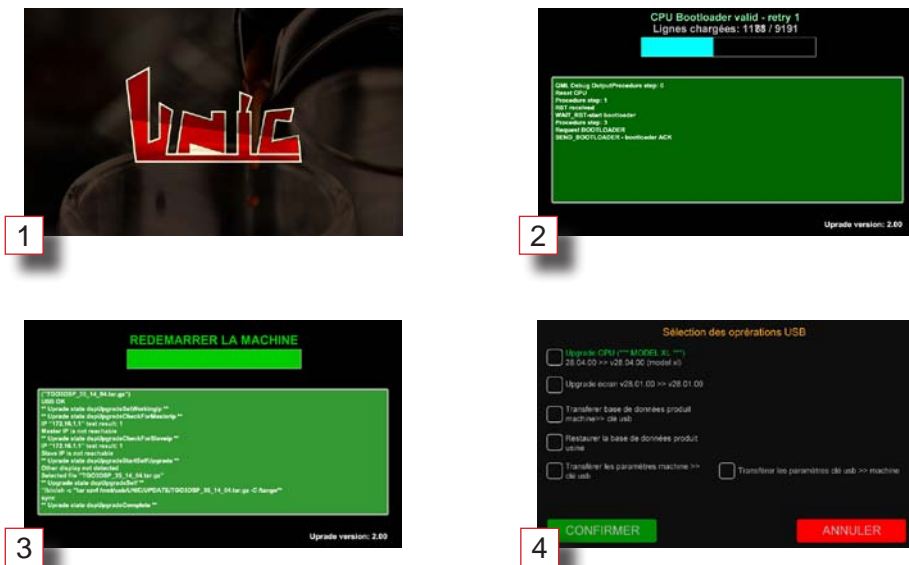

STAGE 3: BGX update

Before updating, check in the CIM that the number of units matches what actually exists. The procedure starts automatically with validation.

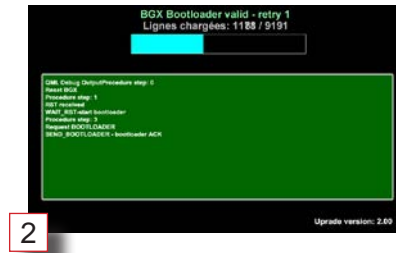

STAGE 4: Export / import products.



◆ Assembly/replacement procedures

When replacing a CPU, you must:

- If possible, save the machine settings on the machine's USB flash drive (Settings > Save > export settings)
- Replace the defective CPU with a new one
- Update the CPU with a USB+ flash drive
- Import the CIM configuration of the USB flash drive of the machine (Settings > Save > import settings) or reconfigure the machine using the CIM menu (Settings> CIM)
- Import the machine configuration (Settings > Save > import settings)

◆ Mother board replacement (CPU)

Dismantling:

Switch the machine off and unplug from the mains

- Loosen the 3 mm BTR screws a few rotations at the bottom of the machine, between the two straight feet.
- Use the suction pad (2) to remove the side by tipping it upwards
- Unplug all the connectors of the board by localising their position for re-assembly
- Unscrew the four nuts fixing the CPU
- Pull the board towards you, keeping it horizontal.

Re-assembly:

- Place the new CPU
- Screw the four nuts
- Plug back the connectors
- Re-assemble the side without forgetting to tighten the fastening screws.

◆ BTA/BGX/BST box replacement

Dismantling:

- Switch the machine off
- Loosen the two screws located under the lateral grids of the cup warmer, about 1 cm then release the grille from the hooks by pushing the screws back
- Tip the grille forward to access the wiring
- Unplug the connectors linking the grille to the machine to remove it.
- Place the grille flat on a protected surface so as not to scratch it and to access the screws on the back.
- Loosen the 3 screws holding the top of the grille enough to remove the top.
- Unplug all the connectors of the box to be changed and removed its four screws.

Re-assembly:

- Place the new box and screw back the boxes
- Plug back the connectors on the changed box
- Replace the top of the grille
- Replace the grille of the machine and plug back all the connectors
- Check that all the grille wires are connected in the right place
- Re-install the grille in the hooks and tighten the screws to close them again
- Switch the machine back on and update the grille (see update procedure).

Necessary tools:

- Flat screwdriver
- 7 mm socket wrench
- Allen key 3 mm
- Suction pad

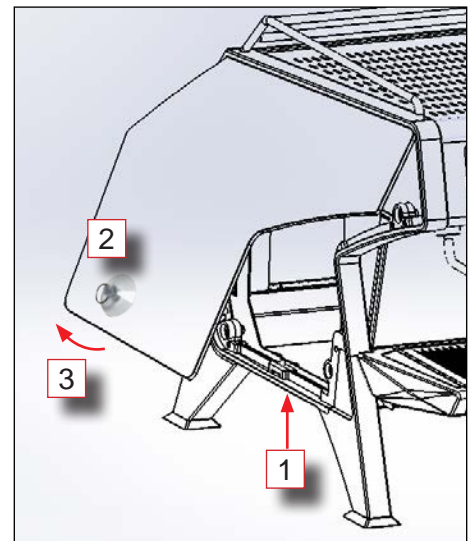

Necessary tools:

- Flat screwdriver
- PZ1 cross-head screwdriver



◆ Cup seal

- Remove the unit cover.
(Important: disconnect the LED cable).
- Remove the cup holder (Allen key #6) and the filter (8 mm socket wrench).
- Loosen the two screws from the tamper and remove the piston spring (photos # 1 and # 2).
- Remove the two O-rings and the cup seal on the piston.
- Clean the assembly.
- Lubricate the seal Ref. [27718](#) (silicone grease) and position it at the base of the unit (photos no. 3 and no. 4).
- Prepare the tamper NZ4007, piston NZ4008 and spring [28828](#) assembly (without seals), and then position and screw the assembly (photo no. 6).
- Install the O-ring [27800](#) (photo No. 7).
- Install the cup seal [PC-17](#) (photo 8).
- Refit the [ID-103](#) filter and the diffuser [31910](#) (pay attention to the direction of the diffuser) (photo no. 9).
- Attach the NZ4011 cup holder.
- Make 2 espressos and check the mobility of the piston and the sealing (photo no. 10)

Refit the LED cable and unit cover assembly.
(Important: reposition the orange wire so that it is not trapped anywhere).



◆ **List of error codes**

ERROR CODE	COMPONENTS AFFECTED		POSSIBLE CAUSES	CONSEQUENCES	SAFETY EXIT CONDITIONS
1	SEA	Mains water pressure probe / switch	Absence of mains water pressure or empty tank: - Check tap or tank	No filling or cycle possible. No heating of coffee boilers if the SNH and SNB probes are not in water	Automatic if defect removed
2	SNH	High level probe	Unplugged or level insufficient after 60 seconds of filling: - Check the probe and wiring - Check the filling circuit.	Filling stopped (see special case of 1st filling)	Automatic if defect removed
3	SNH SNB	High and low level probes	Unplugged or very insufficient level: - Check the probes and wiring - Check the filling circuit.	Steam Boiler heating stopped - Blocking of EVE and EVV outlets - Filling attempt for 60 seconds: - if the level rises to the SNB, the heating starts again - If the level reaches SNH, everything goes back to normal and the EVV and EVE outputs can be used again	Automatic if everything becomes normal again after filling attempt. If not, it is necessary to remove the defect and reset the machine.
4	SNB	Low level probe	Unplugged or hard water when the SNH is in contact with water (normal level): - Check the probe and wiring	Alarm	Automatic if defect removed
5	SNH	High level probe	Unplugged or level insufficient after 3 minutes of 1st filling: - Check the probe and wiring - Check the EVR flow	Filling stopped	Defect removed and Machine reset
6	TSV	STEAM BOILER safety thermostat	Started due to overheating: - Check the STV regulation circuit and TSV thermostat (manual reset)	Steam Boiler heating stopped	Defect removed and manual reset of TSV and machine reset
7	STV	Thermostatic/pressostatic probe STEAM BOILER	Unplugged, no signal: - Check the probe and wiring	Steam Boiler heating stopped	Defect removed and Machine reset
8	STV	Thermostatic/pressostatic probe STEAM BOILER	Short circuited: - Check the probe and wiring	Steam Boiler heating stopped	Defect removed and Machine reset
9	STV	Thermostatic/pressostatic probe STEAM BOILER	Value outside the authorised range: - Check the programmed value and the probe.	Steam Boiler heating stopped	Removed defect
10	TS1	UN1 safety thermostat	Started due to overheating: - Check the SR1 regulation circuit and TS1 thermostat (manual reset)	Unit 1 heating stopped - BG1 box on standby	Defect removed and manual reset of TS1 and machine reset
11	SR1	UNIT 1 thermostatic probe	Unplugged, no signal: - Check the probe and wiring	Unit 1 heating stopped - BG1 box on standby	Defect removed and Machine reset
12	SR1	UNIT 1 thermostatic probe	Short circuited: - Check the probe and wiring	Unit 1 heating stopped - BG1 box on standby	Defect removed and Machine reset
13	SR1	UNIT 1 thermostatic probe	Value outside the authorised range: - Check the programmed value and the probe.	Unit 1 heating stopped - BG1 box on standby	Defect removed and Machine reset
14	DO1	UNIT 1 dosing	Unplugged, no signal: - Check the component and wiring	Manual dosing alarm	Automatic if defect removed
15	DO1	UNIT 1 dosing	Short circuited: - Check the component and wiring	Manual dosing alarm	Automatic if defect removed

ERROR CODE	COMPONENTS AFFECTED		POSSIBLE CAUSES	CONSEQUENCES	SAFETY EXIT CONDITIONS
16	DO1	UNIT 1 dosing	Interruption of counting for more than 5 seconds: - Check free rotation of the dispenser turbine and cabling (defective contact)	Manual dosing alarm	Automatic if defect removed
17	DO1	UNIT 1 dosing	Infusion time longer than 110 seconds, flow too weak: - Check the cleanliness of the water circuit or coarsen the grind.	Infusion cycle stopped	Automatic if defect removed
18	EH1	UNIT 1 DOSAMAT sensor	Unplugged, no signal: - Check the component and wiring	Manual Start alarm	Automatic if defect removed
19	EH1	UNIT 1 DOSAMAT sensor	Short circuited: - Check the component and wiring	Manual Start alarm	Automatic if defect removed
20	TS2	UN2 safety thermostat	Started due to overheating: - Check the SR2 regulation circuit and TS2 thermostat (manual reset)	Unit 2 heating stopped - BG2 box on standby	Defect removed and manual reset of TS2 and machine reset
21	SR2	UNIT 2 thermostatic probe	Unplugged, no signal: - Check the probe and wiring	Unit 2 heating stopped - BG2 box on standby	Defect removed and Machine reset
22	SR2	UNIT 2 thermostatic probe	Short circuited: - Check the probe and wiring	Unit 2 heating stopped - BG2 box on standby	Defect removed and Machine reset
23	SR2	UNIT 2 thermostatic probe	Value outside the authorised range: - Check the programmed value and the probe.	Unit 2 heating stopped - BG2 box on standby	Automatic if defect removed
24	DO2	UNIT 2 dosing	Unplugged, no signal: - Check the component and wiring	Manual dosing alarm	Automatic if defect removed
25	DO2	UNIT 2 dosing	short circuited: - Check the component and wiring	Manual dosing alarm	Automatic if defect removed
26	DO2	UNIT 2 dosing	Interruption of counting for more than 5 seconds: - Check free rotation of the dispenser turbine and cabling (defective contact)	Dosing alarm or Manual stop	Automatic if defect removed
27	DO2	UNIT 2 dosing	Infusion time longer than 110 seconds, flow too weak: - Check the cleanliness of the water circuit or coarsen the grind.	Infusion cycle stopped	Automatic if defect removed
28	EH2	UNIT 2 DOSAMAT sensor	Unplugged, no signal: - Check the component and wiring	Manual Start alarm	Automatic if defect removed
29	EH2	UNIT 2 DOSAMAT sensor	Short circuited: - Check the component and wiring	Manual Start alarm	Automatic if defect removed
30	TS3	UN3 safety thermostat	Started due to overheating: - Check the SR3 regulation circuit and TS3 thermostat (manual reset)	Unit 3 heating stopped BG3 box on standby	Defect removed and manual reset of TS3 and machine reset
31	SR3	UNIT 3 thermostatic probe	Unplugged, no signal: - Check the probe and wiring	Unit 3 heating stopped BG3 box on standby	Defect removed and Machine reset
32	SR3	UNIT 3 thermostatic probe	Short circuited: - Check the probe and wiring	Unit 3 heating stopped BG3 box on standby	Defect removed and Machine reset
33	SR3	UNIT 3 thermostatic probe	Value outside the authorised range: - Check the programmed value and the probe.	Unit 3 heating stopped BG3 box on standby	Automatic if defect removed

ERROR CODE	COMPONENTS AFFECTED		POSSIBLE CAUSES	CONSEQUENCES	SAFETY EXIT CONDITIONS
34	DO3	UNIT 3 dosing	unplugged, no signal: - Check the component and wiring	Manual dosing alarm	Automatic if defect removed
35	DO3	UNIT 3 dosing	short circuited: - Check the component and wiring	Manual dosing alarm	Automatic if defect removed
36	DO3	UNIT 3 dosing	Interruption of counting for more than 5 seconds: - Check free rotation of the dispenser turbine and cabling (defective contact)	Dosing alarm or Manual stop	Automatic if defect removed
37	DO3	UNIT 3 dosing	Infusion time longer than 110 seconds, flow too weak: - Check the cleanliness of the water circuit or coarsen the grind.	Infusion cycle stopped	Automatic if defect removed
38	EH3	UNIT 3 DOSAMAT sensor	Unplugged, no signal: - Check the component and wiring	Manual dosing alarm	Automatic if defect removed
39	EH3	UNIT 3 DOSAMAT sensor	Short circuited: - Check the component and wiring	Manual dosing alarm	Automatic if defect removed
50	DOE	HOT WATER dosing	Unplugged, no signal: - Check the component and wiring	Manual dosing alarm	Automatic if defect removed
51	DOE	HOT WATER dosing	Short circuited: - Check the component and wiring	Manual dosing alarm	Automatic if defect removed
52	DOE	HOT WATER dosing	Interruption of counting for more than 5 seconds: - Check free rotation of the dispenser turbine and cabling (defective contact)	Dosing alarm or Manual stop	Automatic if defect removed
53	DOE	HOT WATER dosing	Cycle time longer than 110 seconds, flow too weak: - Check the cleanliness of the water circuit.	Cycle stop: EVE	Automatic if defect removed
54	STS	StreamAir probe	Unplugged, no signal: - Check the probe and wiring	Alarm, Manual Start	Automatic if defect removed
55	STS	StreamAir probe	Short circuited: - Check the probe and wiring	Alarm, Manual Start	Automatic if defect removed
56	STS	StreamAir probe	Value outside the authorised range: - Check the programmed value and the probe.	Alarm, Manual Start	Automatic if defect removed
57	CP1	UNIT 1 Pressure sensor	Unplugged, no signal: - Check the sensor and wiring	Alarm	Automatic if defect removed
58	CP1	UNIT 1 Pressure sensor	short circuited: - Check the sensor and wiring	Alarm	Automatic if defect removed
59	CP1	UNIT 1 Pressure sensor	Value outside the authorised range: - Check the programmed value and the sensor.	Alarm - Sensor not taken into account - Setpoint pressure replaced by time lag (see coffee cycle with pre-infusion)	Automatic if defect removed
60	CP2	UNIT 2 Pressure sensor	Unplugged, no signal: - Check the sensor and wiring	Alarm	Automatic if defect removed
61	CP2	UNIT 2 Pressure sensor	short circuited: - Check the sensor and wiring	Alarm	Automatic if defect removed

ERROR CODE	COMPONENTS AFFECTED		POSSIBLE CAUSES	CONSEQUENCES	SAFETY EXIT CONDITIONS
62	CP2	UNIT 2 Pressure sensor	Value outside the authorised range: - Check the programmed value and the sensor.	Alarm - Sensor not taken into account - Setpoint pressure replaced by time lag (see coffee cycle with pre-infusion)	Automatic if defect removed
63	CP3	UNIT 3 Pressure sensor	Unplugged, no signal: - Check the sensor and wiring	Alarm	Automatic if defect removed
64	CP3	UNIT 3 Pressure sensor	short circuited: - Check the sensor and wiring	Alarm	Automatic if defect removed
65	CP3	UNIT 3 Pressure sensor	Value outside the authorised range: - Check the programmed value and the sensor.	Alarm - Sensor not taken into account - Setpoint pressure replaced by time lag (see coffee cycle with pre-infusion)	Automatic if defect removed
69	DOG	GENERAL dosing	Unplugged, no signal: - Check the component and wiring	Alarm	Automatic if defect removed
70	DOG	GENERAL dosing	Short circuited: - Check the component and wiring	Alarm	Automatic if defect removed
71	DOG	GENERAL dosing	Interruption of counting for more than 5 seconds: during a coffee or filling cycle - Check free rotation of the dispenser turbine and wiring (defective contact)	Alarm	Automatic if defect removed
72	TSE	WATER BOILER overheating safety mechanism	Started due to overheating: - Check the STE regulation circuit and TSE thermostat (manual reset)	Heating stopped	Defect removed and manual reset of TSE and machine reset
73	STE	WATER BOILER Thermostatic probe	Unplugged, no signal: - Check the probe and wiring	Heating stopped	Defect removed and Machine reset
74	STE	WATER BOILER Thermostatic probe	Short circuited: - Check the probe and wiring	Heating stopped	Defect removed and Machine reset
75	STE	WATER BOILER Thermostatic probe	Value outside the authorised range: - Check the programmed value and the probe.	Heating stopped	Removed defect
76	CPR	GENERAL pressure sensor	Unplugged, no signal: - Check the sensor and wiring	Alarm	Removed defect
77	CPR	GENERAL pressure sensor	Short circuited: - Check the sensor and wiring	Alarm	Removed defect
78	CPR	GENERAL pressure sensor	Value outside the authorised range: - Check the programmed value and the sensor.	Alarm	Removed defect
79	CHU	HUMIDITY sensor	Unplugged, no signal: - Check the sensor and wiring	Alarm	Removed defect
80	CHU	HUMIDITY sensor	Short circuited: - Check the sensor and wiring	Alarm	Removed defect
81	CHU	HUMIDITY sensor	Value outside the authorised range: - Check the programmed value and the sensor.	Alarm	Removed defect
82	USB	DATA TRANSFER	VERSION INCOMPATIBILITY - TRANSFER IMPOSSIBLE	Alarm	Removed defect
83		Fuse no. 1 cut out	NO 230 V ~		
84		Fuse no. 2 cut out	NO 24 V		
85		Fuse no. 3 cut out	NO 12 V		

ERROR CODE	COMPONENTS AFFECTED		POSSIBLE CAUSES	CONSEQUENCES	SAFETY EXIT CONDITIONS
86		Fuse no. 4 cut out	NO 5 V		
87		Fuse no. 5 cut out			
88		Cut out fuse			
89		Cut out fuse			
90		Cut out fuse			
91	DO1	UNIT 1 dosing	Defect on 1st filling: impulse pressure remains at zero when you press for more than 3 seconds or has not fallen below 30 impulses per second in under 3 minutes.	Coffee boiler filling cycle stopped: MPOs stopped - Closing of EV1 and EP1	Defect removed and Machine reset
92	DO2	UNIT 2 dosing	Defect on 1st filling: impulse pressure remains at zero when you press for more than 3 seconds or has not fallen below 30 impulses per second in under 3 minutes.	Coffee boiler filling cycle stopped: MPOs stopped - Closing of EV1 and EP1	Defect removed and Machine reset
93	DO3	UNIT 3 dosing	Defect on 1st filling: impulse pressure remains at zero when you press for more than 3 seconds or has not fallen below 30 impulses per second in under 3 minutes.	Coffee boiler filling cycle stopped: MPOs stopped - Closing of EV1 and EP1	Defect removed and Machine reset
95			Unit filling defect		
96			Defect on unit 1		
97			Defect on unit 2		
98			Defect on unit 3		
101			Version incompatibility		
254			CPU upscaling failure		
255			BGX upscaling failure		