

# AURA



---

EN User manual \*

\*Original instructions



AU9920- 2020.06

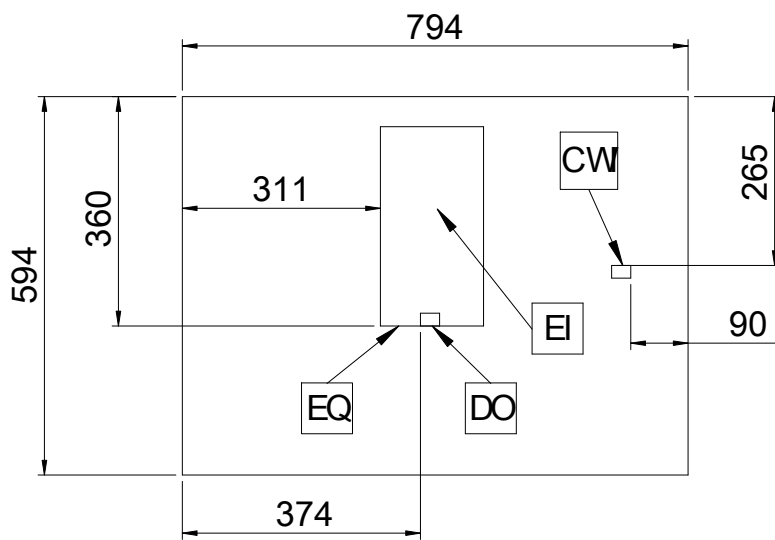
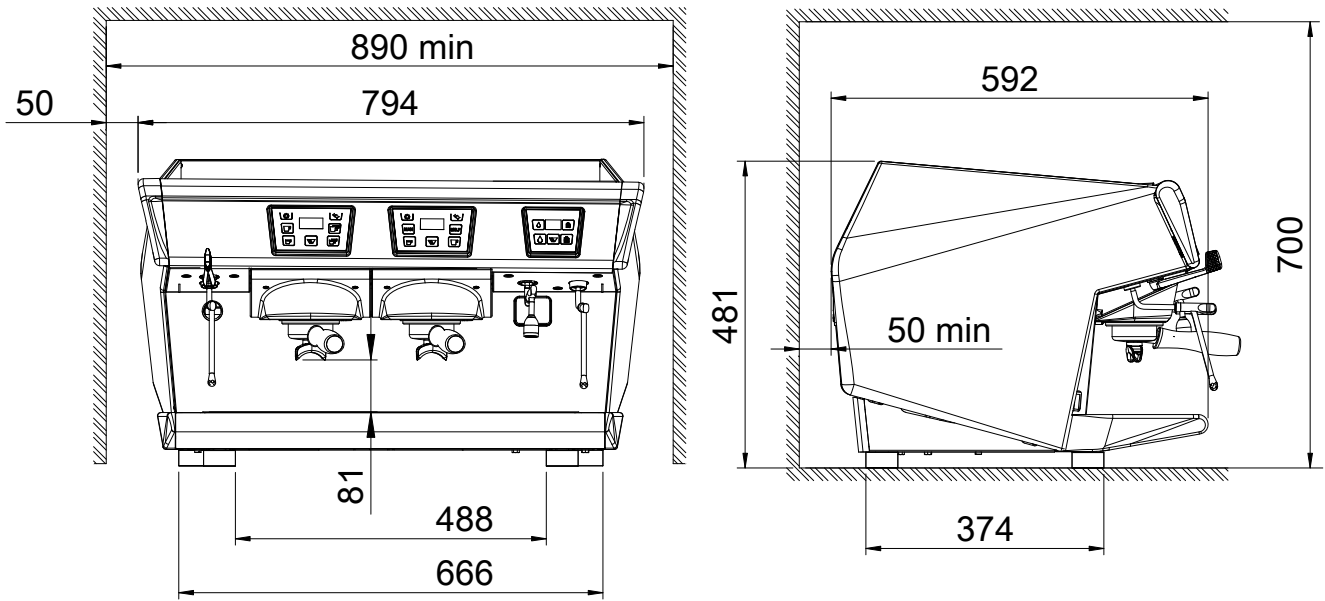

installation diagram

AURA 3

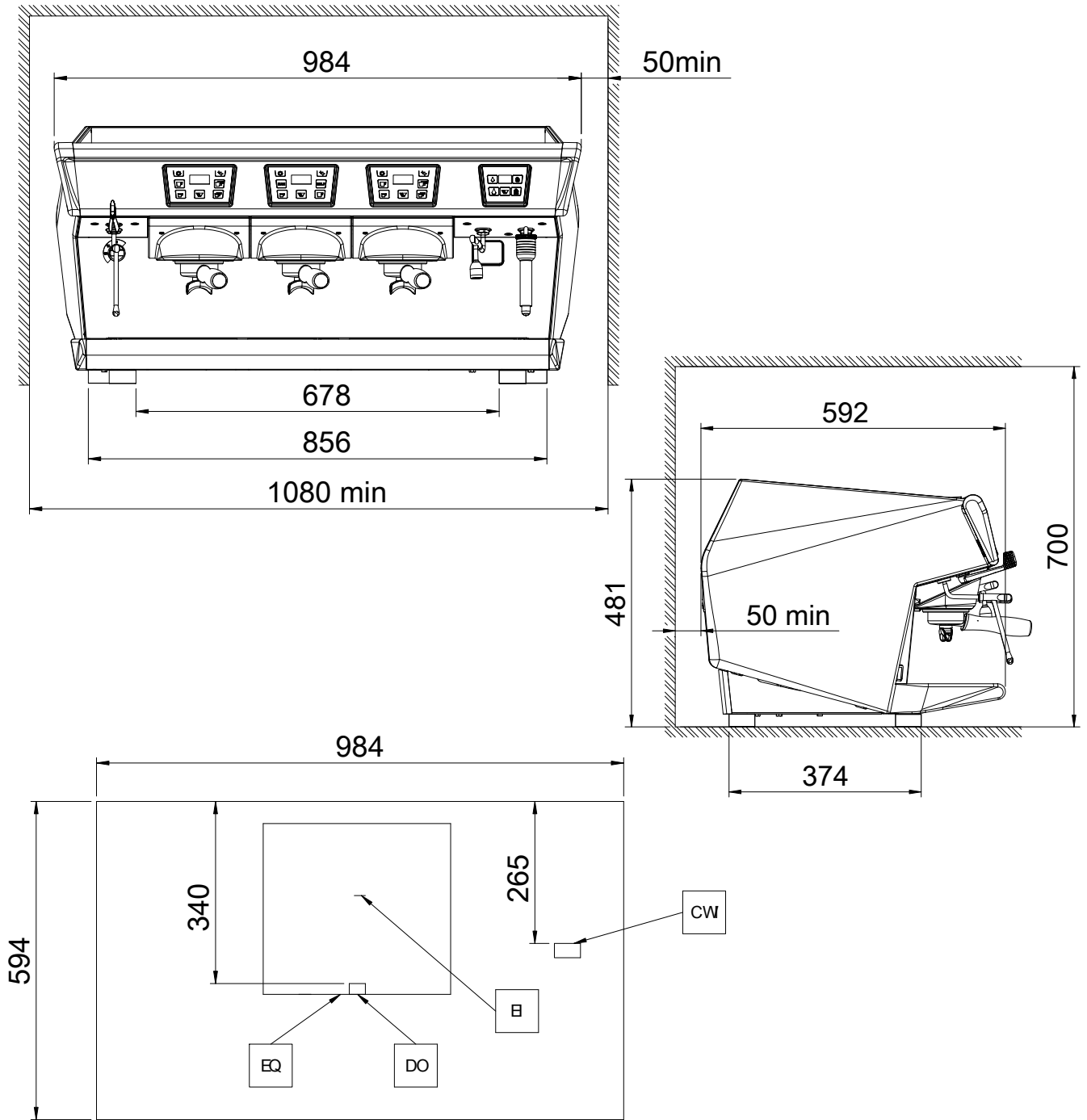

DO = Drain outlet  
EI = Electricity inlet

EQ = Equipotential screw  
CWI = Cold water inlet G 3/8"

## Foreword



The installation, use and maintenance manual (hereinafter Manual) provides the user with information necessary for correct and safe use of the machine (or "appliance").

The following must not be considered a long and exacting list of warnings, but rather a set of instructions suitable for improving machine performance in every respect and, above all, preventing injury to persons and animals and damage to property due to improper operating procedures.

All persons involved in machine transport, installation, commissioning, use and maintenance, repair and disassembly must consult and carefully read this manual before carrying out the various operations, in order to avoid wrong and improper actions that could compromise the machine's integrity or endanger people. Make sure to periodically inform the user regarding the safety regulations. It is also important to instruct and update personnel authorised to operate on the machine, regarding its use and maintenance.

The manual must be available to operators and carefully kept in the place where the machine is used, so that it is always at hand for consultation in case of doubts or whenever required.

If, after reading this manual, there are still doubts regarding machine use, do not hesitate to contact the Manufacturer or the authorised Service Centre to receive prompt and precise assistance for better operation and maximum efficiency of the machine. During all stages of machine use, always respect the current regulations on safety, work hygiene and environmental protection. It is the user's responsibility to make sure the machine is started and operated only in optimum conditions of safety for people, animals and property.



### **IMPORTANT**

- The manufacturer declines any liability for operations carried out on the appliance without respecting the instructions given in this manual.
- The manufacturer reserves the right to modify the appliances presented in this publication without notice.
- No part of this manual may be reproduced.
- This manual is available in digital format by:
  - contacting the dealer or reference customer care;
  - downloading the latest and up to date manual on the web site;
- The manual must always be kept in an easily accessed place near the machine. Machine operators and maintenance personnel must be able to easily find and consult it at any time.

# Contents

A	SAFETY INFORMATION	7
A.1	General information	7
A.2	General safety	7
A.3	Personal protection equipment	8
A.4	Transport, handling and storage	8
A.5	Installation and assembly	9
A.6	Water connection	9
A.7	Electrical connection	9
A.8	Use	10
A.9	appliance cleaning and maintenance	10
A.10	Service	10
A.11	Disposal of packing	10
A.12	Machine disposal	11
B	WARRANTY TERMS AND EXCLUSIONS	11
C	GENERAL SAFETY RULES	11
C.1	Introduction	11
C.2	Mechanical safety characteristics, hazards	11
C.3	Protection devices installed on the machine	11
C.4	Main switch	11
C.4.1	Appliance with 3 positions main switch	12
C.5	Safety signs to be placed on the machine or near its area	12
C.6	Instructions for use and maintenance	12
C.7	Reasonably foreseeable improper use	12
C.8	End of use	12
C.9	Residual risks	12
D	GENERAL INFORMATION	13
D.1	Introduction	13
D.2	Definitions	13
D.3	Machine and manufacturer's identification data	13
D.4	Additional indications	14
D.5	Responsibility	14
D.6	Copyright	14
D.7	Keeping the manual	14
D.8	Recipients of the manual	14
E	NORMAL USE	14
E.1	Characteristics of personnel enabled to operate on the machine	14
E.2	Characteristics of personnel trained for normal machine use	14
E.3	Operator qualified for normal machine use	14
F	TECHNICAL CHARACTERISTICS	15
F.1	Data table	15
G	OPERATING	15
G.1	Switching on	15
G.2	Keyboards	15
G.2.1	4 doses box	15
G.2.2	Dosamat box	16
G.3	How to prepare a cappuccino	16
G.4	Programming	16
G.4.1	Access to parameter	16
G.4.2	Coffee doses	16
G.5	Ambiance lighting	16
H	DAILY CLEANING	16
H.1	Cleaning groups	16
H.1.1	Launching of cleaning volunteer	16
H.1.2	Launching of cleaning after group blocked	17
H.2	External cleaning	17
I	MAINTENANCE	17
I.1	Maintenance intervals	17
I.1.1	Preventive Maintenance	17
I.2	Softener	17
I.3	Machine disposal	17
J	STEAMAIR OPTION	17
J.1	Introduction	17
J.2	Components	17
J.3	Use	18
J.3.1	Automatic mode (To reach the programmed T°C)	18
J.3.2	Manual mode (Over the programmed T°C)	18
J.4	Programming	18
J.4.1	Small hot water delay time adjustment	18
J.4.2	Large hot water delay time adjustment	18
J.4.3	Steam delay time adjustment	18
J.4.4	Steam temperature adjustment	18

---

## A SAFETY INFORMATION

---

### A.1 General information

To ensure safe use of the appliance and a proper understanding of the manual it is necessary to be familiar with the terms and typographical conventions used in the documentation. The following symbols are used in the manual to indicate and identify the various types of hazards:



#### **WARNING**

Danger for the health and safety of operators.



#### **WARNING**

Danger of electrocution - dangerous voltage.



#### **CAUTION**

Risk of damage to the machine or the product.



#### **IMPORTANT**

Important instructions or information on the product



Read the instructions before using the appliance







Clarifications and explanations

### A.2 General safety

- The machine must not be used by people (including children) with limited physical, sensory or mental abilities or without experience and knowledge of it, unless instructed in its use and supervised by those responsible for their safety.
  - Do not let children play with the machine.
  - Keep all packaging and detergents away from children.
  - Cleaning and user maintenance shall not be made by children without supervision.
- For suitable personal protection equipment, refer to chapter “A.3 *Personal protection equipment*”.
- Several illustrations in the manual show the machine, or parts of it, without guards or with guards removed. This is purely for explanatory purposes. Do not install the machine without the guards or with the protection devices deactivated.
- Do not remove, tamper with or make illegible the safety, danger and instruction signs and labels on the machine.
- Do not remove or tamper with the machine’s safety devices.
- Before carrying out any machine installation, always consult the installation manual, which gives the correct procedures and contains important information on safety.
- Unauthorized personnel must not enter the work area.
- Remove any flammable products or items from the work area.
- Machine positioning, installation and disassembly must be carried out by the specialised personnel in conformity with the current safety regulations, regarding the equipment used and the operating procedures.

## A.3 Personal protection equipment

Summary table of the Personal Protection Equipment (PPE) to be used during the various stages of the machine's service life.

Stage	Protective garments 	Safety footwear 	Gloves 	Glasses 	Safety helmet 
Transport	—	●	○	—	○
Handling	—	●	○	—	—
Unpacking	—	●	○	—	—
Installation	○	●	○ <sup>1</sup>	—	—
Normal use	—	○	—	—	—
Adjustments	—	○	○	—	—
Routine cleaning	—	—	○ <sup>2</sup>	—	—
Extraordinary cleaning	○	●	○	○	—
Maintenance	○	●	○	○	—
Dismantling	○	●	●	○	—
Scrapping	○	●	●	○	—
<b>Key:</b>					
●	<b>PPE REQUIRED</b>				
○	<b>PPE AVAILABLE OR TO BE USED IF NECESSARY</b>				
—	<b>PPE NOT REQUIRED</b>				

1. During these operations, gloves must be cut-resistant. Failure to use the personal protection equipment by operators, specialized personnel or users can involve exposure to damage to health (depending on the model).
2. During these operations, gloves must be suitable for contact with chemical substances used (refer to the safety data sheet of the substances used for information regarding the required PPE). Failure to use the personal protection equipment by operators, specialized personnel or users can involve exposure to chemical risk and cause possible damage to health (depending on the model).

## A.4 Transport, handling and storage

- Due to their size, the machines cannot be stacked on top of each other during transport, handling and storage; this eliminates any risks of loads tipping over due to stacking.
- Do not stand under suspended loads during loading or unloading operations. Unauthorized personnel must not enter the work area.
- The weight of the appliance alone is not sufficient to keep it steady.
- For machine lifting and anchoring, do not use movable or weak parts such as: casings, electrical raceways, pneumatic parts, etc.
- Do not push or pull the machine to move it, as it may tip over. Use proper tool to lift the machine.
- Machine transport, handling and storage personnel must be adequately instructed and trained regarding the use of lifting systems and personal protection equipment suitable for the type of operation carried out.

## **A.5 Installation and assembly**

- The installation must be carried out by a specialised personnel.
- Follow the installation instruction supplied with the appliance.
- Do not install a damaged appliance. Any missing or faulty parts must be replaced with original parts.
- Do not make any modifications to the parts supplied with the appliance.
- Disconnect the appliance from the power supply before carrying out any installation procedure. Connect the appliance to the power supply only at the end of the installation.
- The appliance is not suitable for installation outdoors and/or in places exposed to atmospheric agents (rain, direct sunlight, freeze, humid and dusty location, etc.).
- Make sure that the floor where you install the appliance is flat, stable, heat resistant and clean.
- Access to the service area is limited to persons with the necessary knowledge of safety and hygiene as well as practical experience of the device.
- Leave enough free space around the appliance to facilitate its use and to perform any maintenance operations.

## **A.6 Water connection**

- The plumbing connections must be carried out by a specialised personnel.
- The machine is to be connected to the water mains using the new supplied hose-sets. Do not use old hose sets.
- Always use a new set of joints if you remove and re-install the water inlet pipe to the machine.
- Before connection to new pipes, pipes not used for a long time, where repair work has been carried out or new devices fitted (water meters, etc.), let the water flow until it is clean and clear.
- The operating water pressure (minimum and maximum) must be between:
  - 1 bar [0.1 MPa] and 8 bar [0.8 MPa];
- Make sure that there are no visible water leaks during and after the first use of the machine.
- Install an approved dual check valve upstream according to the regulation of the installation country.

## **A.7 Electrical connection**

- Work on the electrical systems must only be carried out by a specialised personnel.
- Make sure that the electrical information on the rating plate agrees with the power supply.
- Make sure to install the appliance in accordance with the safety regulations and local laws of the country where used.
- If the power cable is damaged it must be replaced by the Customer Care Service or in any case by specialised personnel, in order to prevent any risk.
- The appliance must be correctly earthed. The manufacturer is not responsible for the consequences of an inadequate earthing system.
- To protect the power supply of the appliance against short circuits and/or overloads, install a thermal fuse or a suitable automatic thermal magnetic circuit breaker, ADS (Automatic Disconnection of Supply).
- To protect the power supply of the appliance against current leakages, install a high-sensitivity manual reset RCD (Residual Current Device), suitable for overvoltage category III.

For protection against indirect contacts, refer to point 6.3.3 of EN 60204-1 (IEC 60204-1) with the use of protection devices that ensure automatic cut-off of the supply in case of

isolation fault in the TN or TT systems or, for IT systems, the use of isolation controllers or differential current protection devices to activate automatic power disconnection (an isolation controller must be provided for indicating a possible first earth fault of a live part, unless a protection device is supplied for switching off the power in case of a such a fault. This device must activate an acoustic and/or visual signal which must continue for the entire duration of the fault). For example: in a TT system, a residual current device with cut-in current (e.g. 30 mA) coordinated with the earthing system of the building where the appliance is located must be installed ahead of the supply.

## **A.8 Use**

- The appliance must be used in room with an ambient temperature of 5°C to 35°C (41°F - 95°F).
- If it is stored at an ambient temperature below 5°C (41°F) the water circuit (boiler-piping) must be drained.
- In case of emergency (fire, surge, abnormal noise, etc. the first thing to do is to cut off the current and close the water tap.
- Make sure not to obstruct the air inlets of the appliance with towels or other objects.
- Beware of hot surfaces such as cup heaters, the unit heads and the hot water and steam outputs. Never install containers filled with liquid on the top of the appliance.

## **A.9 appliance cleaning and maintenance**

- Refer to “A.3 *Personal protection equipment*” for suitable personal protection equipment.
- Put the appliance in safe conditions before starting any maintenance operation. Disconnect the appliance from the power supply and carefully unplug the power supply cable, if present.
- Depending on the model and type of electric connection, during maintenance operations, the cable and plug must be kept in a visible position by the operator carrying out the work.
- Do not touch the appliance with wet hands or feet or when barefoot.
- Do not remove the safety guards.
- Respect the requirements for the various routine and extraordinary maintenance operations. Non compliance with the instructions can create risks for personnel.
- Extraordinary maintenance, checking and overhaul operations must only be carried out by a specialised personnel or the Customer Care Service, provided with suitable personal protection equipment (safety shoes and gloves), tools and ancillary means.
- Do not clean the appliance with jets of water.

## **Repair and extraordinary maintenance**

- Repair and extraordinary maintenance have to be carried out by specialised authorised personnel. The manufacturer declines any liability for any failure or damage caused by the intervention of an unauthorized technician by the Manufacturer and the original manufacturer warranty will be invalidated.
- The appliance should be descaled only by a specialised personnel.
- Do not forget to regenerate your water softener periodically.

## **A.10 Service**

- Only original spare parts can ensure the safety standards of the appliance.

## **A.11 Disposal of packing**

- Dispose of each packaging items respecting the current regulation in the country of installation.

## A.12 Machine disposal

- Work on the electrical equipment must only be carried out by a specialised personnel, with the power supply disconnected.
- Dismantling operations must be carried out by specialised personnel.
- Make the appliance unusable by removing the power cable and any compartment closing devices, to prevent the possibility of someone becoming trapped inside.
- Refer to “A.3 *Personal protection equipment*” for suitable personal protection equipment.
- When scrapping the machine, the “CE” marking, this manual and other documents concerning the appliance must be destroyed.



### IMPORTANT

Save these instructions carefully for further consultation by the various operators.

---

## B WARRANTY TERMS AND EXCLUSIONS

---

If the purchase of this product includes warranty coverage, warranty is provided in line with local regulations and subject to the product being installed and used for the purposes as designed, and as described within the appropriate equipment documentation.

Warranty will be applicable where the customer has used only genuine spare parts and has performed maintenance in accordance with Electrolux Professional user and maintenance documentation made available in paper or electronic format.

Electrolux Professional strongly recommends using Electrolux Professional approved cleaning, rinse and descaling agents to obtain optimal results and maintain product efficiency over time.

The Electrolux Professional warranty does not cover:

- service trips cost to deliver and pick up the product;
- installation;
- training on how to use/operate;
- replacement (and/or supply) of wear and tear parts unless resulting from defects in materials or workmanship reported within one (1) week from the failure;
- correction of external wiring;
- correction of unauthorized repairs as well as any damages, failures and inefficiencies caused by and/or resulting from:
  - insufficient and/or abnormal capacity of the electrical systems (current/voltage/frequency, including spikes and/or outages);
  - inadequate or interrupted water supply, steam, air, gas (including impurities and/or other that does not comply with the technical requirements for each machine);
  - plumbing parts, components or consumable cleaning products that are not approved by the manufacturer;

- customer’s negligence, misuse, abuse and/or non-compliance with the use and care instructions detailed within the appropriate equipment documentation;
- improper or poor: installation, repair, maintenance (including tampering, modifications and repairs carried out by third parties not authorized) and modification of safety systems;
- Use of non-original components (e. g.: consumables, wear and tear, or spare parts);
- environment conditions provoking thermal (e. g. overheating/freezing) or chemical (e. g. corrosion/oxidation) stress;
- foreign objects placed in- or connected to- the product;
- accidents or force majeure;
- transportation and handling, including scratches, dents, chips, and/or other damage to the finish of the product, unless such damage results from defects in materials or workmanship and is reported within one (1) week of delivery unless otherwise agreed;
- product with original serial numbers that have been removed, altered or cannot be readily determined;
- replacement of light bulbs, filters or any consumable parts;
- any accessories and software not approved or specified by Electrolux Professional.

Warranty does not include scheduled maintenance activities (including the parts required for it) or the supply of cleaning agents unless specifically covered within any local agreement, subject to local terms and conditions.

Check on Electrolux Professional website the list of authorized customer care.

---

## C GENERAL SAFETY RULES

---

### C.1 Introduction

The machines are provided with electric and/or mechanical safety devices for protecting workers and the machine itself.

Therefore the user must not remove or tamper with such devices. The Manufacturer declines any liability for damage due to tampering or their non-use.

### C.2 Mechanical safety characteristics, hazards

The machine does not have sharp edges or protruding parts. The guards for the moving and live parts are fixed to the cabinet with screws, to prevent accidental access.

### C.3 Protection devices installed on the machine

The guards on the machine are (e.g. hopper, side panels, rear, covers, etc.) fixed to the machine and/or frame with screws that can only be removed or opened with tools;

The machine has a main switch that acts as an emergency switch.

### C.4 Main switch

In emergency case the machine can be entire deactivated by the main switch.



#### C.4.1 Appliance with 3 positions main switch



- 0 = appliance OFF
- 1 = power turn ON and filling boiler(s)
- 2 = heating

Turn clockwise the switch from position "0" to "1" to power the appliance.

Turn clockwise the switch from position "1" to "2" to power the appliance.

#### C.5 Safety signs to be placed on the machine or near its area

Prohibition	Meaning
	do not oil, lubricate, repair and adjust moving parts
	do not remove the safety devices
	do not use water to extinguish fires (placed on electrical parts)

Danger	Meaning
	caution, hot surface
	danger of electrocution (shown on electrical parts with indication of voltage)

#### C.6 Instructions for use and maintenance

Risks mainly of a mechanical, thermal and electrical nature exist in the machine. Where possible the risks have been neutralised:

- directly, by means of adequate design solutions.
- indirectly by using guards, protection and safety devices.

Any anomalous situations are signalled on the control panel display.

During maintenance several risks remain, as these could not be eliminated, and must be neutralised by adopting specific measures and precautions.

Do not carry out any checking, cleaning, repair or maintenance operations on moving parts. Workers must be informed of this prohibition by means of clearly visible signs.

To guarantee machine efficiency and correct operation, periodical maintenance must be carried out according to the instructions given in this manual.

Make sure to periodically check correct operation of all the safety devices and the insulation of electrical cables, which must be replaced if damaged.

#### C.7 Reasonably foreseeable improper use

Improper use is any use different from that specified in this manual. During machine operation, other types of work or activities deemed improper and that in general can involve risks for the safety of operators and damage to the appliance are not allowed. Reasonably foreseeable improper use includes:

- lack of machine maintenance, cleaning and periodical checks;
- structural changes or modifications to the operating logic;

- tampering with the guards or safety devices;
- failure to use personal protection equipment by operators, specialised personnel and maintenance personnel;
- failure to use suitable accessories (e.g. use of unsuitable equipment or ladders);
- keeping combustible or flammable materials, or in any case materials not compatible with or pertinent to the work, near the machine;
- wrong machine installation;
- placing in the machine any objects or things not compatible with its use, or that can damage the machine, cause injury or pollute the environment;
- climbing on the machine;
- non-compliance with the requirements for correct machine use;
- other actions that give rise to risks not eliminable by the Manufacturer.



#### WARNING

The previously described actions are prohibited!

#### C.8 End of use

When the appliance is no longer to be used, make it unusable by removing the mains power supply wiring.

#### C.9 Residual risks

The machine has several risks that were not completely eliminated from a design standpoint or with the installation of adequate protection devices. Nevertheless, through this manual the Manufacturer has taken steps to inform operators of such risks, carefully indicating the personal protection equipment to be used by them. In order to reduce the risks, provide for sufficient spaces while installing the unit. To preserve these conditions, the areas around the machine must always be:

- kept free of obstacles (e.g. ladders, tools, containers, boxes, etc.);
- clean and dry;
- well lit.

For the Customer's complete information, the residual risks remaining on the machine are indicated below: such situations are deemed improper and therefore strictly forbidden.

Residual risk	Description of hazardous situation
Slipping or falling	The operator can slip due to water or dirt on the floor
Burns/abrasions (e.g. heating elements, cold pan, cooling circuit plates and pipes)	The operator deliberately or unintentionally touches some components inside the machine without using protective gloves.
Stab wounds	The operator deliberately or unintentionally touches some components with sharp edges during the machine cleaning without using protective gloves.
Burns	The operator deliberately or unintentionally touches some components inside the machine or dishes at the outfeed without using gloves or without allowing them to cool.
Shearing of upper limbs	The operator violently closes the front panels.
Electrocution	Contact with live parts during maintenance operations carried out with the electrical panel powered

Residual risk	Description of hazardous situation
Crushing or injury	The specialised personnel may not correctly fix the control panel when accessing the technical compartment. The panel could close suddenly.
Chemical	Contact with chemical substances (e.g. detergent, rinse aid, scale remover, etc.) without taking adequate safety precautions. Therefore always refer to the safety cards and labels on the products used.



### IMPORTANT

In case of a significant anomaly (e.g. short circuits, wires coming out of the terminal block, motor breakdowns, worn electrical cable sheathing, etc.) the operator must immediately deactivate the machine.

## D GENERAL INFORMATION

### D.1 Introduction

Given below is some information regarding the intended use of this appliance, its testing, and a description of the symbols used (that identifies the type of warning), the definitions of terms used in the manual and useful information for the appliance user.

### D.2 Definitions

Listed below are the definitions of the main terms used in the manual. It is advisable to read them carefully before use.

Operator	machine installation, adjustment, use, maintenance, cleaning, repair and transport personnel.
Manufacturer	Electrolux Professional SpA or any other service centre authorised by Electrolux Professional SpA.
Operator for normal machine use	an operator who has been informed and trained regarding the tasks and hazards involved in normal machine use.
Customer Care service or specialised personnel	an operator instructed/trained by the Manufacturer and who, based on his professional and specific training, experience and knowledge of the accident-prevention regulations, is able to appraise the operations to be carried out on the machine and recognise and prevent any risks. His professionalism covers the mechanical, electrotechnical and electronics fields etc.
Danger	source of possible injury or harm to health.
Hazardous situation	any situation where an operator is exposed to one or more hazards.
Risk	a combination of probabilities and risks of injury or harm to health in a hazardous situation.
Protection devices	safety measures consisting of the use of specific technical means (guards and safety devices) for protecting operators against risks.
Guard	an element of a machine used in a specific way to provide protection by means of a physical barrier.
Safety device	a device (other than a guard) that eliminates or reduces the risk; it can be used alone or in combination with a guard.
Customer	the person who purchased the machine and/or who manages and uses it (e.g. company, entrepreneur, firm).
Electrocution	an accidental discharge of electric current on a human body.

### D.3 Machine and manufacturer's identification data

An example of the marking or data plate on the machine is given below:

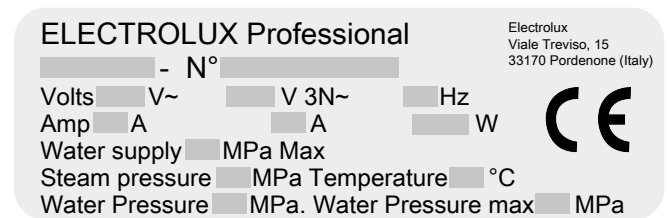

The data plate gives the product identification and technical data. The meaning of the various information given on it is listed below:

AURA	commercial description
N°	serial number
Volts (V)	power supply voltage (monophase and/or triphase)
Hz	power supply frequency
Amp (A)	electrical intensity
W	max power input
Steam pressure (MPa)	boiler pressure
Temperature (°C)	boiler temperature
Water pressure (MPa)	water network pressure
Water pressure max (MPa)	max water network pressure
CE	CE marking
Electrolux Professional SpA Viale Treviso 15 33170 Pordenone Italy	manufacturer

The data plate is located on the front of the equipment.

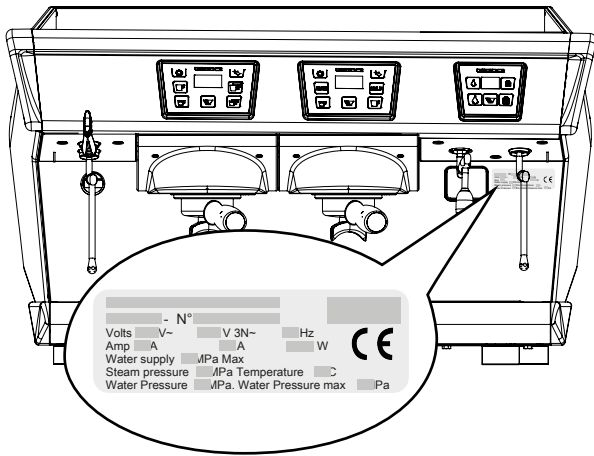

#### IMPORTANT

When installing the machine, make sure the electrical connection is carried out in compliance with that specified on the data plate.



#### NOTE!

Refer to the data given on the machine's data plate for relations with the Manufacturer (e.g. when ordering spare parts, etc.).

### D.4 Additional indications

The drawings and diagrams given in the manual are not in scale. They supplement the written information with an outline, but are not intended to be a detailed representation of the machine supplied.

The numerical values given on the appliance installation diagrams refer to measurements in millimeters and/or inches.

### D.5 Responsibility

**The Manufacturer declines any liability for damage and malfunctioning caused by:**

- non-compliance with the instructions contained in this manual;
- repairs not carried out in a workmanlike fashion, and replacements with parts different from those specified in

## E NORMAL USE

### E.1 Characteristics of personnel enabled to operate on the machine

The Customer is responsible for ensuring that persons assigned to the various duties:

- read and understand the manual;
- receive adequate training and instruction for their duties in order to perform them safely;
- receive specific training for correct machine use.

### E.2 Characteristics of personnel trained for normal machine use

The Customer must make sure the personnel for normal machine use are adequately trained and skilled in their duties, as well as ensuring their own safety and that of other persons.

The Customer must make sure his personnel have understood the instructions received and in particular those regarding work hygiene and safety in use of the machine.

the spare parts catalogue (the fitting and use of non-original spare parts and accessories can negatively affect machine operation and invalidates the original manufacturer warranty);

- operations carried out by non-specialised personnel;
- unauthorized modifications or operations;
- missing, lack or inadequate maintenance;
- improper machine use;
- unforeseeable extraordinary events;
- use of the machine by uninformed and / or untrained personnel;
- non-application of the current provisions in the country of use, concerning safety, hygiene and health in the workplace.

The Manufacturer declines any liability for damage caused by arbitrary modifications and conversions carried out by the user or the Customer.

The employer, workplace manager or service technician are responsible for identifying and choosing adequate and suitable personal protection equipment to be worn by operators, in compliance with regulations in force in the country of use.

The Manufacturer declines any liability for inaccuracies contained in the manual, if due to printing or translation errors.

Any supplements to the installation, use and maintenance manual the Customer receives from the Manufacturer will form an integral part of the manual and therefore must be kept together with it.

### D.6 Copyright

This manual is intended solely for consultation by the operator and can only be given to third parties with the permission of ELECTROLUX.

### D.7 Keeping the manual

The manual must be carefully kept for the entire life of the machine, until scrapping. The manual must stay with the machine in case of transfer, sale, hire, granting of use or leasing.

### D.8 Recipients of the manual

**This manual is intended for:**

- the employer of machine users and the workplace manager
- operators for normal machine use
- specialised technicians - Customer Care service (see service manual).

### E.3 Operator qualified for normal machine use

Must have at least:

- knowledge of the technology and specific experience in operating the machine;
- adequate general basic education and technical knowledge for reading and understanding the contents of the manual, including correct interpretation of the drawings, signs and pictograms;
- sufficient technical knowledge for safely performing his duties as specified in the manual;
- knowledge of the regulations on work hygiene and safety.

In case of a significant anomaly (e.g. short circuits, wires coming out of the terminal block, motor breakdowns, worn

electrical cable sheathing, etc.) the operator for normal machine use must:

## F TECHNICAL CHARACTERISTICS

### F.1 Data table

MODELE	AURA 2	AURA 3
Width	790 mm [31"]	980 mm [38.5"]
Height	480 mm [19"]	480 mm [19"]
Depth	600 mm [23.6"]	600 mm [23.6"]
Weight	70 kg [154.3 Lbs]	80 kg [176.3 Lbs]
200V single phase	3.5 kW (option 2.3)	3.5 kW
220V single phase 380V three phases + neutral	4.3 kW (option 2.7)	4.3 kW
230V single phase 400V three phases + neutral	4.7 kW (option 3)	4.7 kW
240V single phase 415V three phases + neutral	5.1 kW (option 3.2)	5.1 kW
Temperature	118 to 120°C / 244 to 248°F	
Steam pressure	0.9 to 1 bar / 0.09 to 0.1 MPa	
Pump pressure	9 bar / 0.9 MPa	
High pressure valve	13 bar / 1.3 MPa	
Low pressure valve	3.2 bar / 0.3 MPa	
Dose of ground coffee	7 gr	
Dose of water	5 to 7 cl	
Infusion time	20 to 25 s	

## G OPERATING



**NOTE!**  
When the machine has been installed and the hydraulic, electrical connections have been carried out by a qualified installer.



**WARNING**  
Do not forget to open the water tap supplying the machine.

### G.1 Switching on

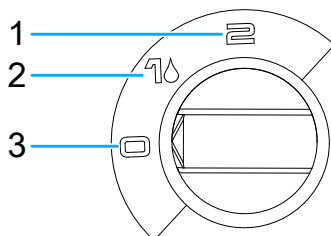

Fig. 1 Main switch

1. Heating
2. power turn ON and filling boiler(s)
3. appliance OFF

#### Turn ON the appliance:

Put the main On/Off switch on position 1 (do not put it on position 2 until the boiler is full). The On/Off indicator switches on and the boiler level is set automatically. The water-intake indicator blinks to show that the boiler is filling.

#### Heating:

When the water-intake indicator stops blinking, put the switch on position 2 to start the heating process. When the correct

temperature has been reached, the steam pressure is approximately 0.9 to 1 bar [0.09 to 0.1 MPa].

### G.2 Keyboards

#### G.2.1 4 doses box

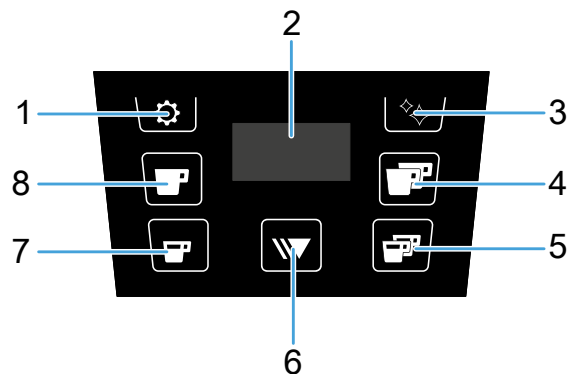

1. Programming icon
2. Display
3. Cleaning icon
4. 2 large cups icon
5. 2 small cups icon
6. Continu/stop icon
7. 1 small cup icon
8. 1 large cup icon

## G.2.2 Dosamat box

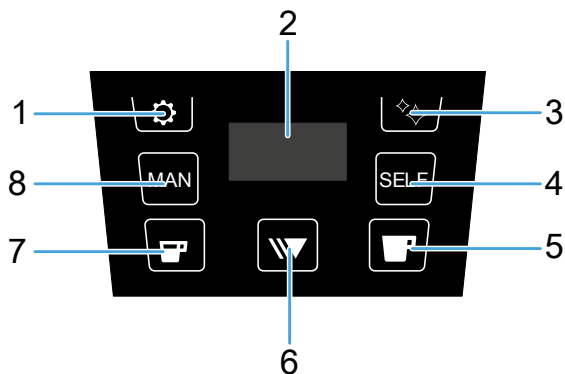

1. Programming icon
2. Display
3. Cleaning icon
4. Self mod icon (automatic start of coffee cycle)
5. Large cup(s) icon, number of coffee according to the engaged filter holder (1 or 2 cups)
6. Continu/stop icon
7. Small cup(s) icon, number of coffee according to the engaged filter holder (1 or 2 cups)
8. Manual mod icon (manual start of coffee cycle)

## G.3 How to prepare a cappuccino

- Use a high narrow container half-full of cold milk (preferably skimmed).
- Keep the end-piece of the steam tube at the surface to obtain a fine foam.
- After each use, clean the steam tube with a wet rag and press a moment on the steam tap to eliminate the small amount of milk remaining in the tube.



NOTE!

Be careful to not boil the milk

## G.4 Programming

Description icons function for settings

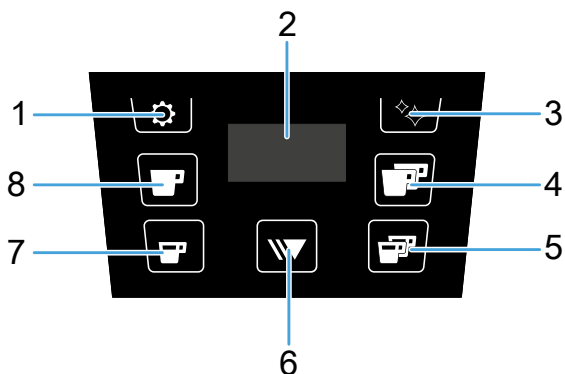

1. Scroll button level 1
2. Display
3. Input touch and validation of levels 2, 3 & 4
4. Disabled touch
5. Touch (+)
6. Disabled touch

7. Touch (-)
8. Disabled touch

### G.4.1 Access to parameter

Double authentication to enter in setting :

- Step 1: press 3 seconds on programming icon
- Step 2: press simultaneously during 3 seconds on cleaning and continu/stop icons to enter in settings.



NOTE!

- If you press on any other icons (prog and coffee icons) return to stand by mode.
- After 10s, the machine return to stand by mode.

### G.4.2 Coffee doses

Scrolling the menus with programming icon , and select the menu , confirm the enter in the menu with the cleaning icon .

4 doses box: the touches **4 5 6 7 8** are programmable.

Dosamat box: the touches **5 6 7** are programmable.



NOTE!

The continuous/stop icon, possibility to set as a 3rd dose, by default the continuous cycle has a security stop at 180 s.

#### Procedure:

- Press desired touch to launch a coffee cycle.
- When the dose is reached, press the same touch again to stop the cycle and memorize the dose.
- Repeat the same procedure for the other touches.
- Validate the settings, stay pressed 3 seconds on the cleaning icon .



NOTE!

For the dosamat case, the box detects the number of cups when it is switched on, so make adjustments with the different filter holder, 1 cup and 2 cups.

The programming is independent on the coffee electronics boxes, it is possible to copy the dose settings from one box to another, using the function.

- After programming the doses on group 1, go to the submenu, then confirm the data copying by selecting (all the icons flash).
- Go to another coffee electronics box (ex: group 2) select the submenu , then validate by selecting to confirm the transfer of data to group 2 all icons flash, to indicate the validation.
- To exit the menu, press 3 seconds the programming icon on one of the groups.

## G.5 Ambiance lighting

The light switch is located on the left side of the machine, near the basin. It allows to light the front panel. If your AURA is equipped with the lighting of the cups, it is this same switch that controls it. 0=OFF & 1=ON.

## H DAILY CLEANING



### H.1 Cleaning groups

**Pre alert:** at 130 coffees (default) the light become yellow.  
**Group blocked:** at 150 coffees (default) the light become red.  
**Cleaning mode:** press the cleaning touch to enter in cleaning mode.

#### H.1.1 Launching of cleaning volunteer

- Press the cleaning touch during 3 seconds (it turns blinking blue when entering cleaning mode).
- Then follow the same instructions for cleaning after blocking.

### H.1.2 Launching of cleaning after group blocked

- Press the cleaning icon  (it turns blinking blue).
- Put a detergent pellet above the rubber plug (ref. DO197) then insert and tighten the filter-holder in the unit.
- Press the icon  to launch the cleaning cycle (2s ON / 8s OFF x 10 sequences). Display shows nP (cleaning).
- When the display shows rP: take off the filter-holder from the unit and wait the end of the rinsing cycle (3x 30 seconds).
- At the stop of the automatic cycle: put back the filter-holder without the plug and without coffee then start a 2 large cups cycle to rinse it.

## H.2 External cleaning

### Steam output tube:

After each use, clean the steam outlet with a damp cloth and release steam for a short time to eliminate the small residue of milk which has been able to remain in the tube. (Remove the tip of the steam pipe for easier cleaning).

### Rinsing the decompression circuit:

- Engage the cup on the unit by tightening it.
- Press a coffee touch to pressurize the cup, and then stop the unit. Repeat the operation several times by emptying the water contained in the cup each time.

### Rinsing the cup seal:

- Engage the filter—holder on the unit without tightening it.
- Press a coffee touch by tightening and loosening the filter—holder alternately, to create a leak at the level of the seal to clean it.

### Basin grille

Remove the basin grille by lifting it up from the front. Clean the basin with a sponge.

### Bodywork

Use a soft cloth and alcohol for the stainless steel parts, and a nonabrasive cleaning agent for the painted parts. Simply take care not to scratch the painted parts.

### Keyboards cleaning



#### IMPORTANT

Never clean keyboard with liquid when the machine is in normal operation.

- Turn OFF the machine by main switch (position 0).
- Clean the keyboards and the front panel with a smooth towel and an adequate cleaning product.
- When the cleaning is done, turn ON the main switch (position 2).

## I MAINTENANCE

### I.1 Maintenance intervals

The inspection and maintenance intervals depend on the actual machine operating conditions and ambient conditions (presence of dust, damp, etc.), therefore precise time intervals cannot be given. In any case, careful and periodical machine maintenance is advisable in order to minimise service interruptions.

#### I.1.1 Preventive Maintenance

Preventive Maintenance reduces downtime and maximizes machines efficiency.

Customer Care Service can provide advice on the best maintenance plan to be purchased based on the intensity of use and the age of the equipment.

It is advisable to stipulate a preventive and scheduled maintenance contract with the Customer Care Service.

### I.2 Softener

Test the water hardness of the network and refer to the technical documentation of the water softener used for optimum adjustment.

A softener must be changed every 1 year, even if it does not reach the end of its filtering capacity.

### I.3 Machine disposal

At the end of the product's life cycle, make sure the equipment is not dispersed in the environment. The equipment must be disposed of in compliance with current regulations in the country of use.

All metal parts are in stainless steel (AISI 304) and removable. Plastic parts are marked with the letters of the material.

The symbol  on the product indicates that this product should not be treated as domestic waste, but must be correctly disposed of in order to prevent possible negative consequences for the environment and the human health.

Regarding the recycling of this product, please contact the sales agent or dealer of your product, your Customer Care service or the appropriate waste disposal service.

## J STEAMAIR OPTION

### J.1 Introduction

The Steamair option allows, particularly when making cappuccino, to foam the milk very easily and automatically: the supply of air mixed with steam brings milk to a programmed temperature (60° to 70°) and foams it.

The stop is done automatically when the temperature is reached which saves milk from boiling. By this way the milk qualities are preserved.

**Once the air/steam adjustment is defined, the operation is as follows:**

- Insert the Steamair outlet into the milk container.
- Push on the Steamair touch.
- Wait for it to stop automatically.

The Steamair box also controls a timed steam and hot water outlet.

### J.2 Components

Setting foam

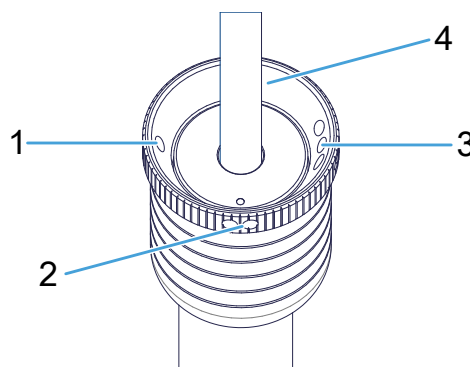

1. Level 1 Very fine foam
2. Level 2 Fine foam

3. Level 3 Medium foam
4. Steam only

### J.3 Use

#### J.3.1 Automatic mode (To reach the programmed T°C)

One impulse on the touch makes the Steamair flow until the liquid reaches the preset temperature. You can stop it manually by pushing again on the touch.

#### J.3.2 Manual mode (Over the programmed T°C)

If after the stop in automatic mode (temperature reached) you wish to continue the heating, you have to press again the touch. Then you go into manual mode and the outlet is again activated. To stop you will have to push again on the same touch. If you don't do it, it will be stopped automatically by one of the two safeties: after 180 seconds or when the liquid temperature reaches 96°C.

### J.4 Programming

The programming mode allows adjusting the steam and hot water time together with the Steamair level temperature adjustment.

The electronic box enter automatically in programming (blinking icons), when we follow the procedure "G.4.1 Access to parameter".

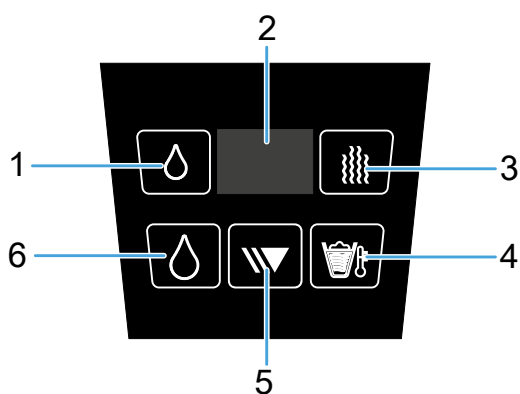

1. Hot water icon (small dose)
2. Display
3. Steam icon
4. Steamair icon
5. Continu/stop icon
6. Hot water icon (large dose)

#### J.4.1 Small hot water delay time adjustment

- Press on the icon , let the desired time flow (the time in seconds is indicated on the display).
- Press again on the same icon to stop the cycle.

#### J.4.2 Large hot water delay time adjustment

- Press on the icon , let the desired time flow (the time in seconds is indicated on the display).
- Press again on the same icon to stop the cycle.

#### J.4.3 Steam delay time adjustment

- Press on the icon , let the desired time flow (the time in seconds is indicated on the display).
- Press again on the same icon to stop the cycle.

#### J.4.4 Steam temperature adjustment

- The steam tip must be at least 1" below the surface of the milk.
- Press the button with the icon . The milk probe temperature is displayed on the screen. (Use a separate thermometer for more accuracy).
- Re-press the button when the desired temperature is reached.
- The new value is saved automatically.



#### NOTE!

Note: The temperature adjustment can be done in a range of 50°C to 90°C. The default is 62°C.

Once all settings, exit the programming mode to validate the settings.



CE

Electrolux Professional SPA  
Viale Treviso 15  
33170 Pordenone  
[www.electroluxprofessional.com](http://www.electroluxprofessional.com)