



MG22 MEAT & FOOD GRINDER OPERATOR'S MANUAL



Persons under age 18 are not permitted to operate or have accessibility to operate this equipment per U.S. Dept. Of Labor Employment Standards Administration Fact Sheet No. ESA913.

**TO INSURE BOTH SAFE AND TROUBLE-FREE
PERFORMANCE, WE STRESS THAT ALL
PERSONNEL THAT WILL BE INVOLVED WITH
YOUR NEW UNIVEX MEAT GRINDER MUST READ
AND UNDERSTAND THESE INSTRUCTIONS
BEFORE ATTEMPTING TO OPERATE THIS UNIT.**

WE APPRECIATE YOUR COOPERATION AND YOUR
BUSINESS. SHOULD THERE BE A QUESTION OR IF
WE CAN BE OF FURTHER ASSISTANCE, PLEASE
CALL US.

1-603-893-6191

TABLE OF CONTENTS

<u>DESCRIPTION</u>	<u>PAGE</u>
TABLE OF CONTENTS	1
LIST OF ILLUSTRATIONS	1
INSPECTION	2
SAFETY	3
INSTALLATION	5
ASSEMBLY AND OPERATING INSTRUCTIONS	5
CLEANING INSTRUCTIONS	6
WARRANTY	BACK COVER

LIST OF ILLUSTRATIONS

<u>ILLUSTRATION</u>	<u>PAGE</u>
FIGURE 1 OVERALL VIEW	4
FIGURE 2 GRINDER ASSEMBLY	6

MG22 MEAT GRINDER

INSTRUCTION MANUAL

Welcome to Univex

Thank you for purchasing this Univex Product.

Your new MG22 Meat Grinder has been designed with advanced performance and safety features that make it an excellent addition to your food preparation equipment. Like all Univex mixers, slicers, meat grinders and accessories, this power unit is engineered to provide years of reliable service.

If you have any questions concerning the operation of this unit, or if we can be of further assistance, please call our Customer Service Department for the location of your nearest service representative.

Univex Customer Service:

USA & Canada 800-258-6358

International 603-893-6191

Or visit us on-line at www.univexcorp.com under service agents.

The UNIVEX Model MG22 Meat Grinder consists of a 1 HP electric motor power base which drives a bell-shaped meat grinder designed to utilize industry standard #22 knives and a full range of #22 grinding plates. Included as standard equipment is a carbon steel knife, a 3/16 grinding plate, an aluminum stomper, a 16 X 24 aluminum feed pan and a 18.5 X 13.5 storage container with a lid for collecting meat as it is processed.

The MG22 meat grinder has safety and ease of operation built into it. The permanent safety guard positioned over the bell-shaped feed hopper prevents accidental entry of the operator's fingers and hands into the grinder. The readily removable feed pan and storage container provide ease of processing and cleaning.

Noise emissions for this meat grinder are below 70 db. (A).

INSPECTION

All Univex MG22 meat grinders are inspected prior to packaging to assure the machine quality, correct inclusion of options, and the proper voltage. However, upon unpacking, all items should be carefully inspected and verified that they are correct. Any damage, imperfections, or shortages should be reported immediately to your dealer or directly to the Univex Customer Service Department, and/or the shipping carrier.

SAFETY IS OUR TOP PRIORITY

READ AND MAKE SURE THAT YOU UNDERSTAND THE INSTRUCTIONS AND SAFETY WARNINGS IN THIS BOOKLET BEFORE ATTEMPTING TO OPERATE THIS POWER UNIT.

IT IS A VIOLATION OF UNITED STATES DEPARTMENT OF LABOR REGULATIONS TO PERMIT OPERATION OF THIS UNIT BY ANY PERSON UNDER THE AGE OF 18 YEARS.

FIRST TIME OPERATORS SHOULD BE PROPERLY TRAINED IN SAFETY PRECAUTIONS AND IN THE PROPER USE AND SERVICING OF THIS EQUIPMENT AND ATTACHMENTS.

SWITCH THE POWER “OFF” BEFORE CONNECTING THE UNIT TO THE POWER SOURCE.

SWITCH THE POWER “OFF” AND DISCONNECT THE POWER SUPPLY CORD BEFORE MOUNTING OR DISMOUNTING ANY ATTACHMENT OR FOR CLEANING OR SERVICING THE UNIT

THE KNIFE IS **SHARP** AND CAN CUT FINGERS. USE CAUTION WHEN HANDLING THE KNIFE.

ALWAYS SECURELY MOUNT THE GRINDER, FULLY INSERT THE WORM ASSEMBLY INTO THE DRIVE AND SNUG THE KNIFE, PLATE AND RING ONTO THE GRINDER BEFORE SWITCHING THE POWER ON.

ALWAYS REMOVE THE GRINDER FROM THE POWER DRIVE UNIT BEFORE CLEANING. NEVER WASH OR RINSE THE GRINDER ASSEMBLY WHILE MOUNTED TO THE DRIVE UNIT AS THIS WILL INVITE ELECTRICAL SHOCK.

WIPE DOWN THE EXTERIOR OF THE DRIVE UNIT ONLY, NEVER HOSE DOWN OR IMMERSE THE DRIVE UNIT IN WATER.

DO NOT ATTEMPT TO SERVICE THE DRIVE ASSEMBLY. PLEASE CONTACT UNIVEX CORPORATION FOR THE NUMBER OF THE NEAREST AUTHORIZED SERVICE AGENT IN YOUR AREA FOR ADJUSTMENTS OR REPAIR.

OVERALL VIEW OF THE MG22
FIGURE 1

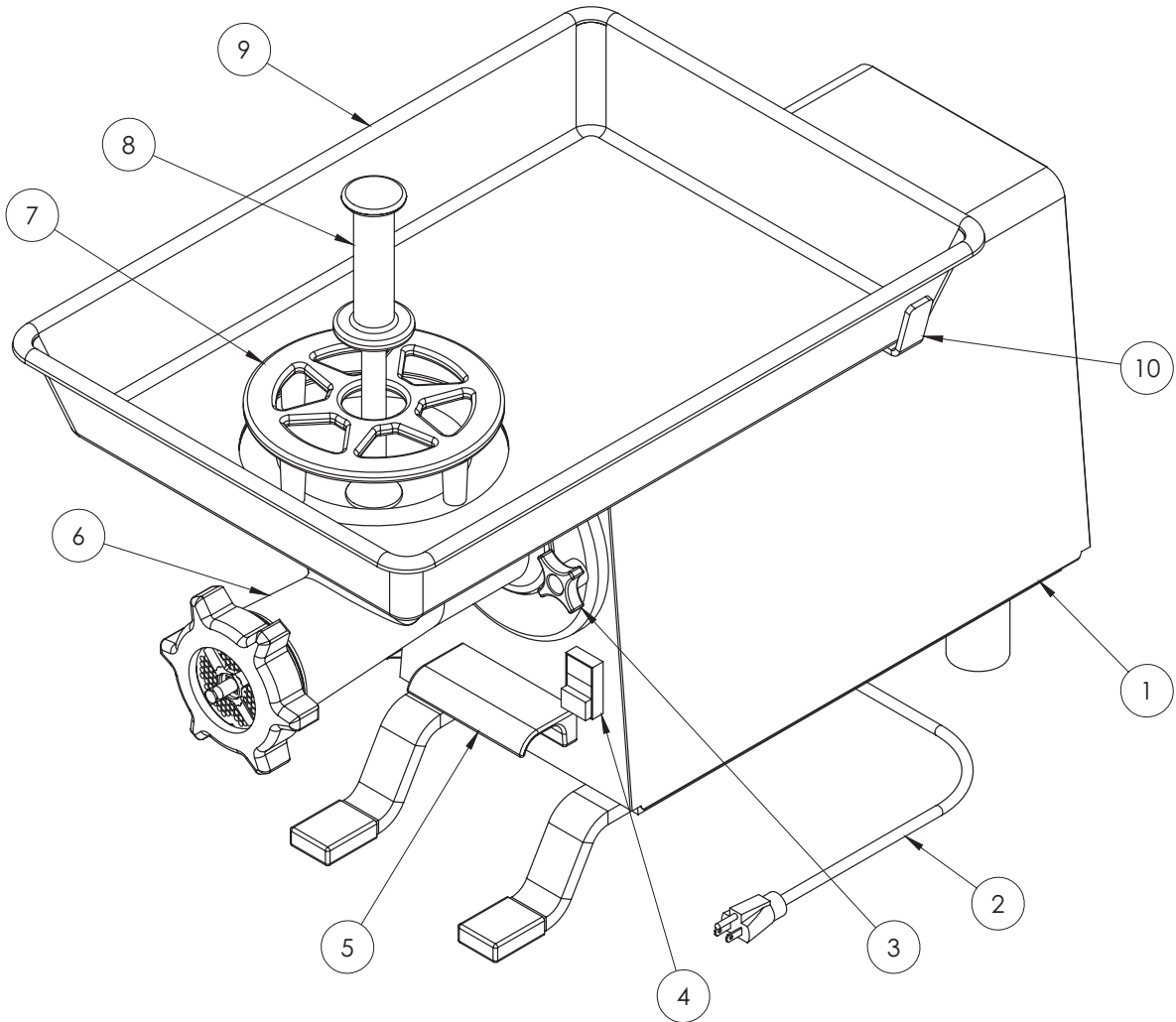

- | | |
|--------------------------|-----------------------------|
| 1. POWER UNIT | 7. SAFETY GUARD |
| 2. POWER CORD | 8. STOMPER |
| 3. GRINDER MOUNTING KNOB | 9. FEED PAN |
| 4. POWER SWITCH | 10. FEED PAN SUPPORT |
| 5. TUB CLIP | 11. TUB & COVER (NOT SHOWN) |
| 6. GRINDER ASSEMBLY | |

INSTALLATION

- This is a table-top unit. The grinder may be secured to a table top via the shipping bolt threaded holes on the bottom of the power drive housing.
- Insure that the grinder is located on a flat, level and stable surface. There should be sufficient clearance around the grinder for safety and ease of operation. Sufficient space must be provided for the feed pan and the clip-on storage container.
- The feed pan support bracket must be assembled onto the housing cover using the screws provided.

ASSEMBLY AND OPERATING INSTRUCTIONS

ASSEMBLY:

WARNING: DISCONNECT THE ELECTRICAL POWER SUPPLY CORD PRIOR TO ASSEMBLY.

1. Mount the grinder housing onto the studs on the power drive housing and firmly tighten the mounting knobs.
2. Slide the worm assembly into the grinder housing and into the drive coupling in the power drive unit.
3. Slide the knife, with the sharp edges toward the plate, onto the square on the worm assembly.
4. Slide the plate onto the worm assembly and screw the ring onto the grinder housing until it is just snug. Too much pressure on the ring can damage the grinder.

WARNING: The knife is very sharp and can cut fingers.

5. Place the feed pan onto the pan support and over the grinder throat making sure to align the locating pin with the small hole in the feed pan.
6. Locate the storage container under the clip and resting on the front legs of the power unit.
7. Connect the electrical power supply cord and turn on the power switch.

WARNING: NEVER put fingers or utensils into the throat of the grinder or the knife and plate.

PROCESS:

1. Cut meat to be processed to fit under or through the safety guard. The recommended size is 1½ thick X 3 inches wide X 12 inches long. Place the meat strips into the feed pan.
2. With the grinder running, slide the product under the guard on the grinder housing or through the opening in the top of the grinder housing. Use the meat stomper to guide the product into the grinder.
3. Collect the ground meat in the storage container.

CLEANING INSTRUCTIONS

1. Turn the grinder off and disconnect the power supply cord.
2. Disassemble the grinder in the reverse order of the assembly instructions:
Remove the storage container and feed pan.
Remove the ring, plate and knife.
WARNING: The knife is very sharp and can cut fingers.
Slide the worm assembly from the grinder housing.
Unscrew the two knobs and remove the grinder housing from the power unit.
3. Wash all the components including the drive coupling, use the brush provided to clean areas that are difficult to access. Rinse, sanitize and air dry the components
4. Apply a small amount of food grade lubricant to the bronze bushing located inside the grinder housing before use.

GRINDER ASSEMBLY
FIGURE 2

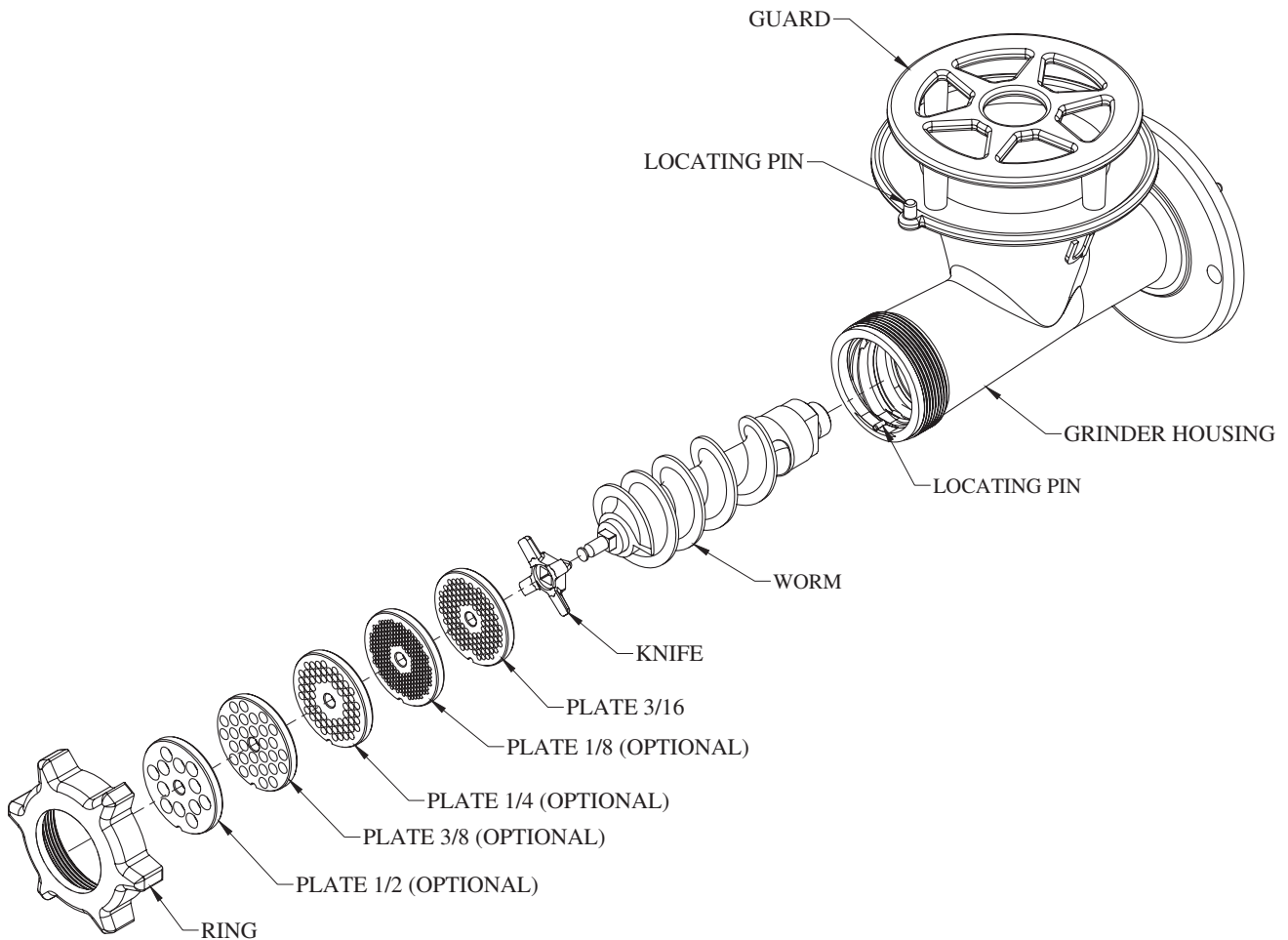

MG22 ACCESSORIES

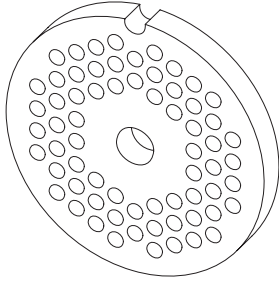
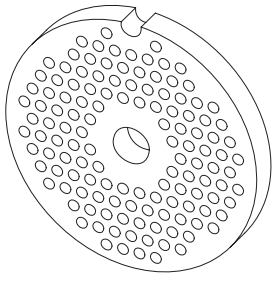
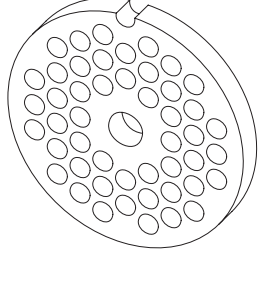
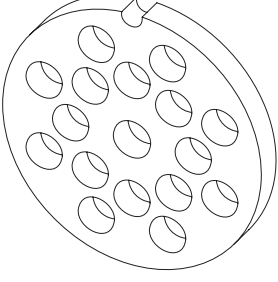
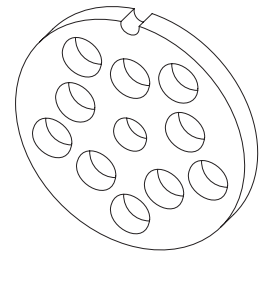
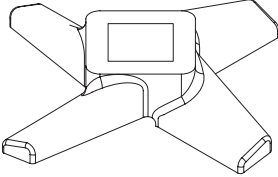
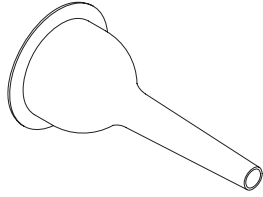
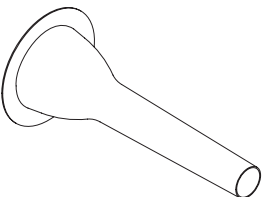
<p>Plate 3/16 Standard 1000727</p> 	<p>Plate 1/8 Optional 1000726</p> 
<p>Plate 1/4 Optional 1000728</p> 	<p>Plate 3/8 Optional 1000729</p> 
<p>Plate 1/2 Optional 1000730</p> 	<p>Knife Standard 1000725</p> 
<p>Sausage Stuffer 1/2 Optional 1000733</p> 	<p>Sausage Stuffer 3/4 Optional 1000734</p> 

Warranty

The Univex MG22 Meat Grinder carries a one-year, on-site parts and labor warranty against any defects in materials or workmanship. The one-year period begins on the date of purchase by the end user and remains in full effect provided the unit is used properly and in accordance with our instructions. Any work to be performed under this warranty must be performed between the hours of 8:00 am and 5:00 pm local time, Monday through Friday. Univex will not cover overtime charges of any kind. Please call the Univex Warranty Service Department at 800-258-6358 to report warranty claims before arranging repair or attempting to return the unit to Univex Corporation.

Damages incurred in transit or incurred because of installation error, accident, alteration, or misuse are not covered by this warranty. Transit damages should be reported to the carrier immediately.

Univex will not be liable for any consequential, compensatory, incidental or special damages.

