



MIND Maps™

SERVICE MANUAL



HOW TO USE THIS MANUAL

This manual covers general information and troubleshooting of the oven range CHEFTOP and BAKERTOP MIND.Maps™.

This manual is split into twelve parts and each part is divided into different sections in order to present information and data in a user-friendly way.

The electronic version of the manual is available in PDF format and allows to access the content by clicking the mouse on the text or on the page numbers marked in blue.



The digital version of the manual, which is available in PDF format, is interactive, a simple “click” on the text or on the page numbers directly accesses the indicated contents.

CONTACTS

UNOX S.p.A.

Via Majorana, 22 - 35010 - Cadoneghe (PD) - Italy
Tel.: +39 049 86.57.511 - Fax: +39 049 86.57.555

info@unox.com

www.unox.com

All rights reserved.

This document is property of UNOX S.p.A. and is strictly confidential. No part of this document shall be distributed or reproduced in any form except with prior and express written permission by UNOX S.p.A. The access, the copy and the diffusion of this document with no written authorization by UNOX S.p.A. represent a violation of the current laws and could be prosecuted.

CONTENTS

INTRODUCTION	4
POWER BOARD LAYOUTS	8
SOFTWARE UPDATE	46
SERVICE MENU USER SETTING PARAMETERS	59
STEAM.MAXI™ - DRY.MAXI™	66
AIR.MAXITM.....	71
SELF CLEANING SOLENOID VALVES	74
CHEFTOP MIND.MAPS™ BIG.....	83
CHEFTOP MIND.MAPS™ BIGZERO	89
SPIDO.GAS™ THEORY AND PRACTICE	103
FAULT MESSAGE GUIDE	129
NON ALARM PROBLEMS	209



Introduction

Buttons on control panel of one and plus models.....	6
Components on the back of the electric oven.....	7
Components on the back of the gas oven.....	7

READING THE OVEN LABEL

The label is always placed on the right side of the oven. The product ID provide the following information:

- X for type of product;
- Reference marker (Europe, USA, Japan, Marine);
- Ovens range (CHEFTOP-BAKERTOP MIND.Map-s™, CHEFTOP-BAKERTOP MIND.Map-s Compact-T™);
- Series;
- Number of trays;
- Type of trays;
- Heating type (Electric, Gas, Electric High Voltage, Single Phase);
- Control/Version;
- Door's side opening;
- Possible Customization..

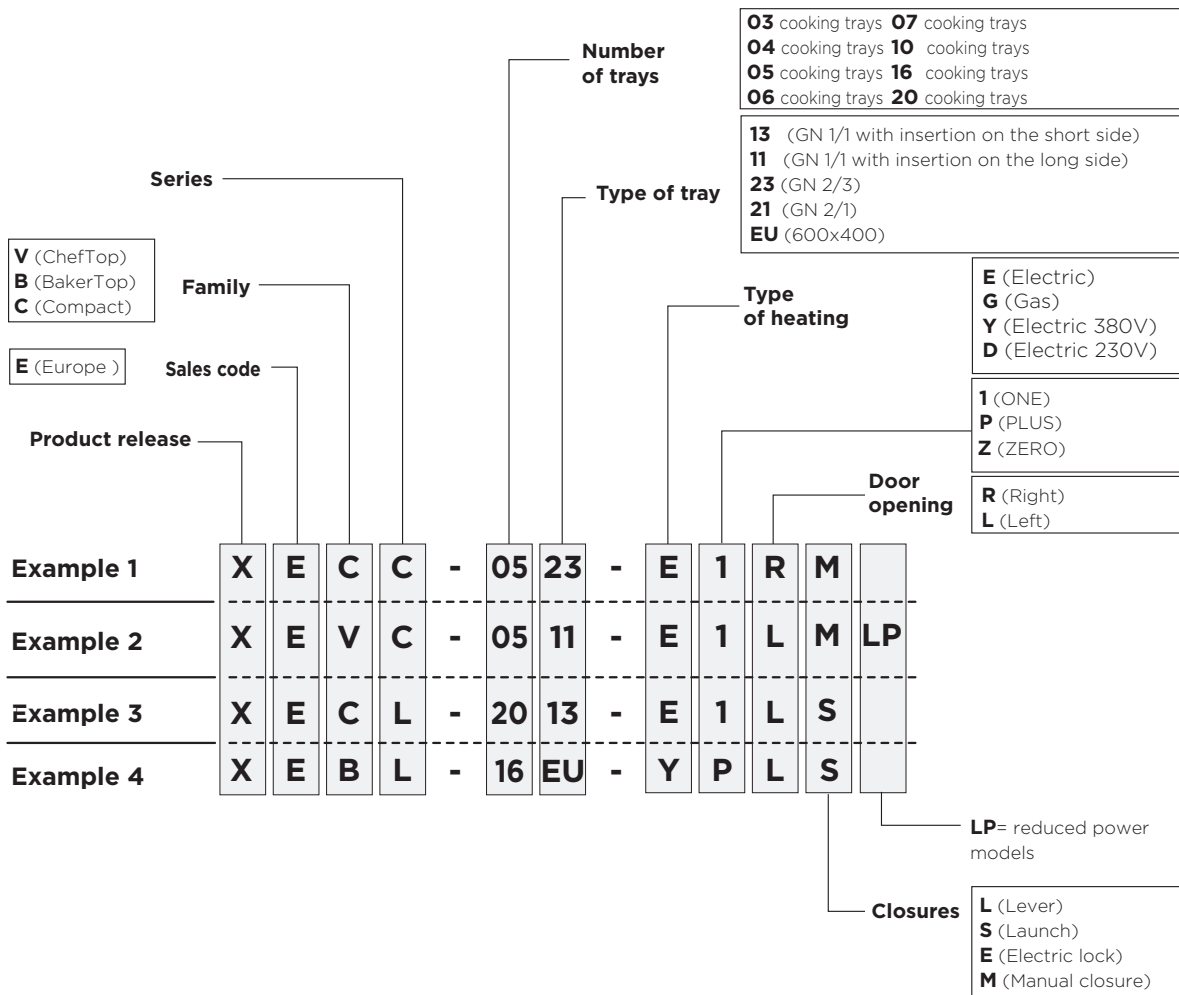
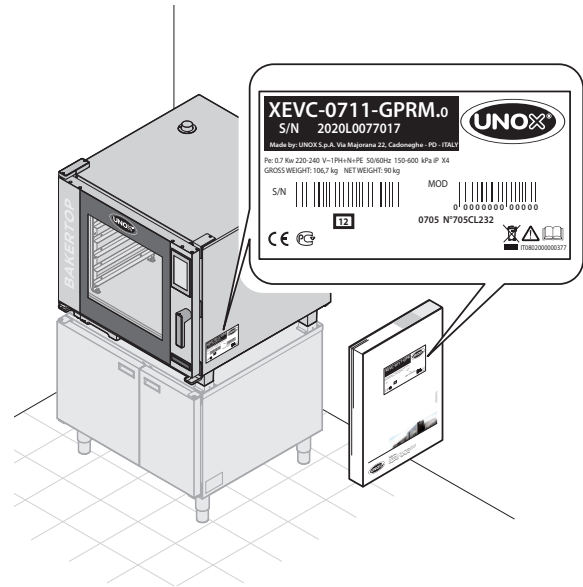

DOMAIN	COD.	DESCRIPTION
Type of product	X	Oven
Reference marker	E	Europe
	A	America
	J	Japan
	M	Marine
Ovens range	V	CHEFTOP MIND.Map™
	B	BAKERTOP MIND.Map™
	C	CHEFTOP-BAKERTOP MIND.Map Compact™
	C	CHEFTOP MIND.Maps™
	L	CHEFTOP MIND.Maps™ BIG PLUS
Number of trays	3	3 trays
	4	4 trays
	5	5 trays
	6	6 trays
	7	7 trays
	10	10 trays
	16	16 trays
	20	20 trays
Type of trays	11	GN1/1
	23	GN2/3
	21	GN2/1
	EU	600X400 (European Pastry)
	FS	Full Size
	HS	Half Size
	QS	Quarter Size
	13	Compatible GN1/3
Heating type	E	Electric
	G	Gas
	Y	Only Star Electric
	D	Delta Electric Connection
	H	Electric High Voltage
	M	Single-phase
Control/Version	P	Plus
	1	One
	M	Manual
Door's side opening	R	Right
	L	Left
	D	Drop down
Closure	S	SLAM (only for BIG)
Possible Customization	AD	Aldi
	VV	Vandemoortele
	LT	La Lorraine
	WL	Walmart
	AU	Australia

BUTTONS ON CONTROL PANEL OF ONE AND PLUS MODELS

PLUS

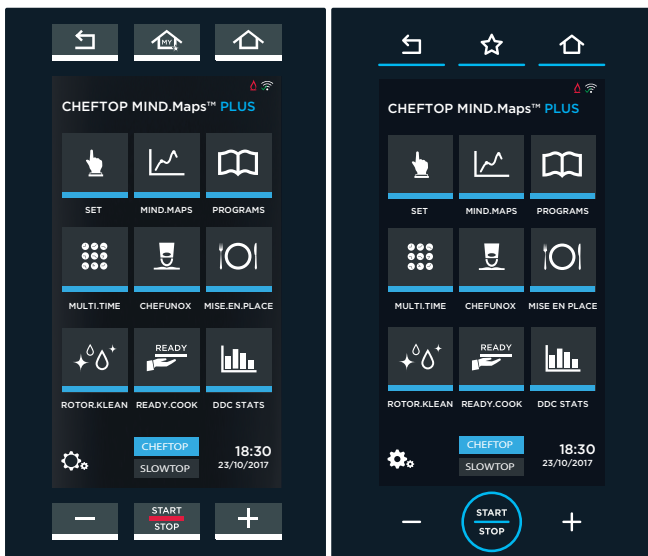

Old panel

New panel

ONE



Old panel

New panel



SET

Setting a cooking program manually



MIND.MAPS

Setting cooking parameters by drawing graphics adjusting, etc.



PROGRAMS

List of cooking programs previously saved using the menu SET or MINDMAPS.



ROTOR.KLEAN

List of available washing programs.



SETTINGS

The button used access the User Setting, Service Menu and Network.

PASSWORDS:

- USER SETTINGS 4456
- SERVICE MENU 99857



MULTI.TIME

Cooking up to 10 different products in each tray in the oven so that the products are ready to serve at different times. Tray loading is at the time but the trays are ready at different times.



CHEF.UNOX

A list of recipes created by Unox chefs. The recipes vary depending on the region and can be modified.



MISE EN PLACE

Suggests the correct order and timing for inserting trays inside the baking chamber to have all the meals ready at the same time.



READY.COOK

Menu to access some preset programs, to start cooking methods quickly.



DDC STATS

This menu is used to retrieve a HACCP data and to control the consumption.

Additional features of "PLUS" version which are not available "ONE" Version

COMPONENTS ON THE BACK OF THE ELECTRIC OVEN

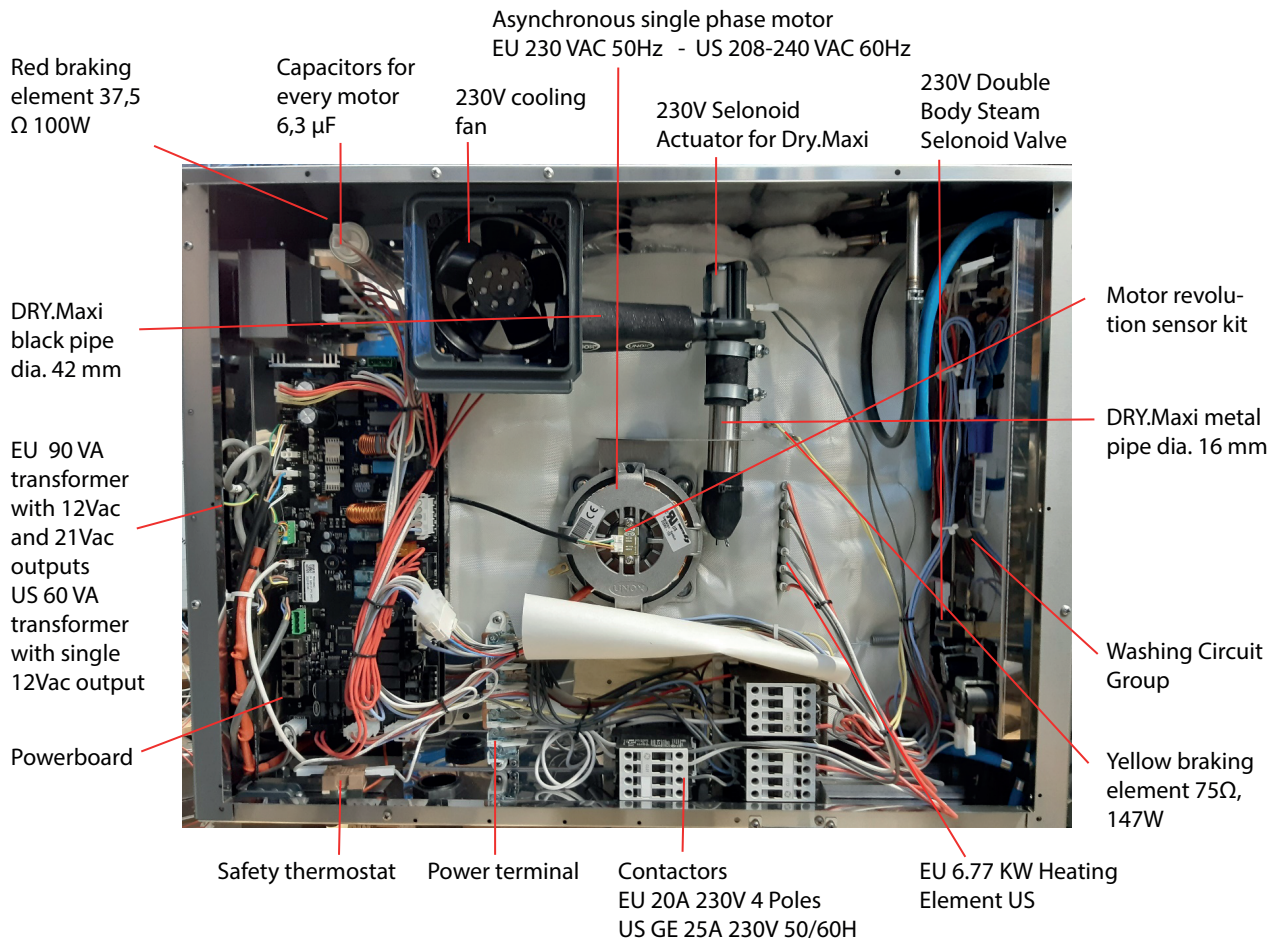

COMPONENTS ON THE BACK OF THE GAS OVEN

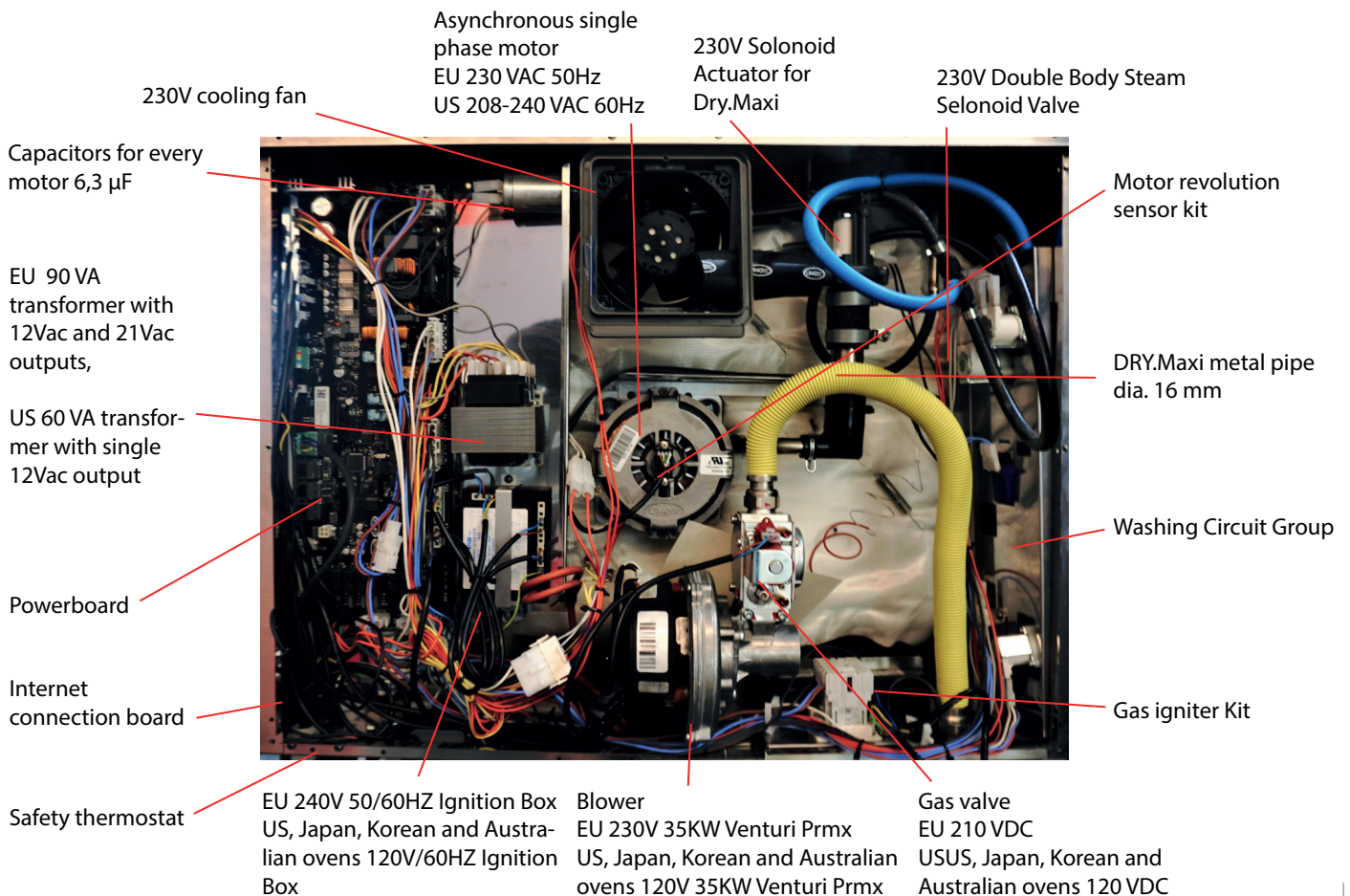

Power board layouts

One model Power board PE2037.....	11
Plus Electric Model Power board PE2038.....	16
MIND.MAPS EU Gas 120 Premix Power Board PE2021.....	23
MIND.MAPS US Gas 120 Premix Power Board PE2022.....	30
CHEFTOP MIND.Maps™ BIG Power Board PE2143.....	37
CHEFTOP MIND.Maps™ ZERO Power Board PE2102.....	41

Figure 1 below represents the electrical schematic of a countertop oven. Line 3 directly feeds the board through the P1 socket. Phase 1, 2 and 3 power the heating elements through the contactors as depicted in **Table 1**.

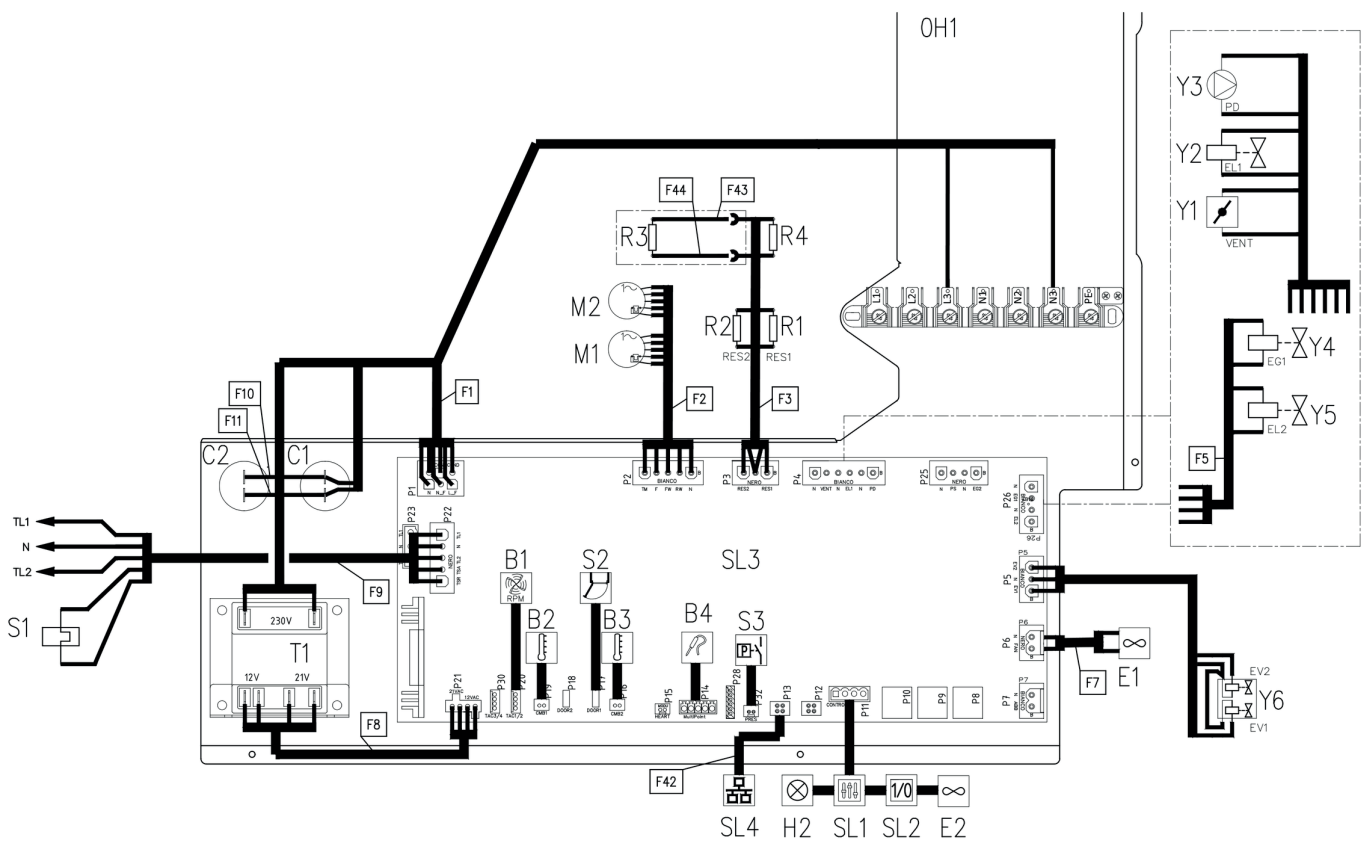

Figure 1
Electrical oven electrical scheme

Table 1

Other than the 3P + N + PE 380 – 400 V connection in the DTC, other electrical connection are shown. To perform special connections not written in the DTC, refer to the table below that describes the special kit on available on request to convert the electrical connection.

Model ID	220-240 V ~3PH+PE			Recommended size Cu 90°C [mm ²]	CIRCUIT BREAKER [A]
	I _{L1} [A]	I _{L2} [A]	I _{L3} [A]		
XECC-1013-EPxM	45,5	47,5	47,5	10	50
XEVC-1011-EPRxM XEVC-1011-E1RxM XEVC-1011-EZRxM	45,5	47,5	47,5	10	50
XEBC-10EU-EPxM XEBC-10FS-EPxM-AL	51	54	54	10	63
XEBC-10EU-E1xM	38,5	37	37	10	50

Model ID	220-240 V ~1PH+N+PE	Recommended size Cu 90°C [mm ²]	CIRCUIT BREAKER [A]
	I _{L1} [A]		
XECC-0513-EPxM	41	10	50
XEVC-0511-EPRxM XEVC-0511-E1RxM XEVC-0511-EZRxM	41	10	50
XEVC-0711-EPRxM XEVC-0711-E1RxM XEVC-0711-EZRxM	51,5	10	63
XEBC-04EU-EPxM	46,5	10	50
XEBC-06EU-EPxM XEBC-06FS-EPxM-AL	61,5	10	63
XEBC-06EU-E1xM	43	10	50

The power board supplies 230 V AC to the transformer across the pins NF and LF of the P1 socket. The primary turn of the transformer is powered at 230 VAC. The secondary turn of the transformer converts the 230 VAC into 12/21 VAC for PLUS models and into only 12 VAC for ONE models.

The F2 fuse (size: 2 A – 250 V, type: Fast Acting) is in between the power board and the transformer primary turn. When the transformer is shorted, the F2 blows to protect the circuits of the power board.

The power board receives the low voltage from the secondary turn of the transformer into P21 socket. In the PLUS version, there is normally 12 VAC and 21 VAC across the yellow wires and red wires respectively. In the ONE version there is only 12 VAC across the yellow wires. The F4 fuse (size: 4 A – 250 V, type: Time Delayed) is in -between the transformer secondary turn and the power board. When one or more low voltage components are shorted, the F4 fuse blows to protect the secondary turn of the transformer, see **Figure 2**.

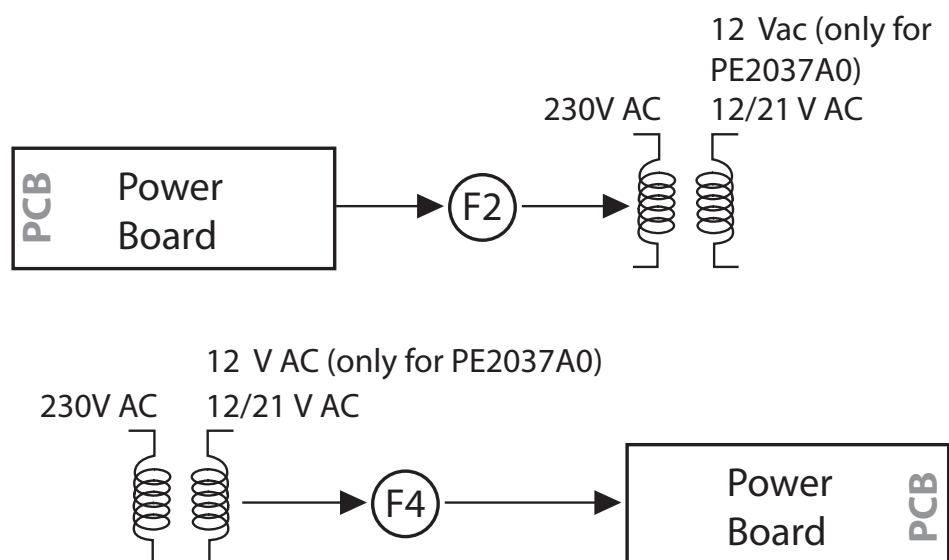

Figure 2
Electrical oven electrical scheme

The UNOX MIND.Maps™ ovens come with different power boards according to the range and the source of power supply. The table below sums up the power boards installed in UNOX MIND.Maps™ devices.

Table 2

MIND.Maps™ power boards

Range	Power supply source	Power board
ONE	Only electric	PE2037
PLUS	Electric	PE2038
PLUS	Gas European version	PE2021
PLUS	Gas US version	PE2022
ZERO	Only electric	PE2102

The main differences among the power boards are summarized in the table below.

Table 3

Power board main differences

Power board	Dedicated temperature reading circuit	Multi-point core probe	Pressure switch input	Back side fan guard cleaning solenoid valve	21 V AC input	TL1 and TL2 contactor group relay	Micro switch of the Pollo system valve input	Diagnosis sensor
PE2037	NO	NO	NO	NO	NO	NO	NO	NO
PE2038	YES	YES	YES	YES	YES	YES	YES	YES
PE2021	YES	YES	YES	YES	YES	YES	YES	YES
PE2022	YES	YES	YES	YES	YES	YES	YES	YES
PE2102	NO	NO	NO	NO	NO	NO	NO	NO

The differences among the European and US gas oven power board are reported in the table below.

Table 4

Gas oven power board differences

Power board	Second flame control board power supply socket	Flame control board power supply relay (RL23)	Second flame control board socket for gas alarm reset and heat demand
PE2021B0	NO	NO	NO
PE2022A0	YES	YES	YES

PE2037A GENERAL DESCRIPTION

The PE2037A is a circuit board with its main functions being:

- managing the loads of the oven (contactors, motors, solenoid valve, etc.)
- reading the measurements provided by the different sensors (temperature probes, door switch, etc.)
- powering the low voltage of the entire system
- communicating through CANBUS with the control board
- communicating through (RS485) with possible bridge boards

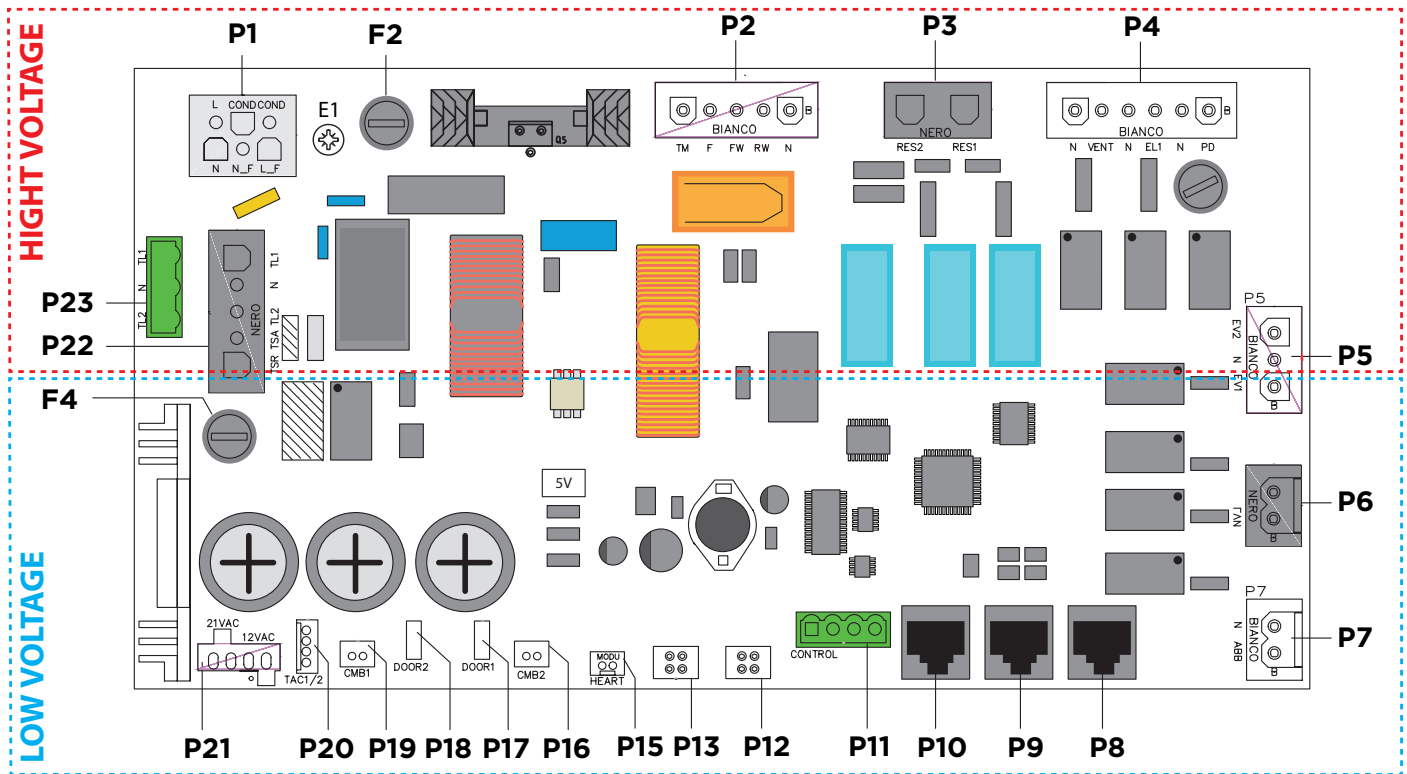

► Output

NAME	LOAD DESCRIPTION	ACTUALIZATION	VOLTAGE	CURRENT (MAX N°LOAD)	TYPE OF LOAD	MAX N° LOAD	HARDWARE OUTPUT
TL_1	Contactors	Relay (RL8)	230 Vrms	150 mA	A	5	✓
EV_1	Low steam turn	Relay (RL4)	230 Vrms	60 mA	B	2	✓
EV_2	High steam turn	Relay (RL5)	230 Vrms	60 mA	B	2	✓
VENT	DRY.Maxi solenoid	Relay (RL3)	230 Vrms	35 mA	G	1	✓
PD	Detergent pump	Relay (RL14)	140 Vrms	370 mA	C	2	✓
EL_1	Washing solenoid from tap water	Relay (RL2)	230 Vrms	30 mA	B	1	✓
ABB	Cooling drainage solenoid	Relay (RL7)	230 Vrms	30 mA	B	1	✓
FAN	Cooling fan	Relay (RL6)	230 Vrms	260 mA	E	2	✓
RES_1	Braking element 1	Relay (RL10)	230 Vrms	-	-	5	✓
RES_2	Braking element 2	Relay (RL11)	230 Vrms	-	-	5	✓
MOT_FWRW	Motor revolution direction	Relay (RL12)	-	-	-	-	✓
STBY	Neutral cut off	Relay (RL13)	-	-	-	-	
TRIAC	Motor triac control	Triac	230 Vrms	8 A	F	5	✓

REF.	DESCRIPTION	SUPPLIER	I	V	F	P	Q	S	PF	L @ 100Hz	R @ 100Hz	Z @ 100Hz	DCR	X/R	θ
A	Contacteur	VE1095A0 / GE- CL01A400T	30 mA	230 V ~	50 Hz	2 W	6 Var	6.5 Va	0.31	13 H	2 kΩ	9.4 kΩ	770 Ω	4.42	77.2°
B	Solenoid valve	VE1135A0 / RPE – SERIE R	30 mA	230 V ~	50 Hz	4.7 W	4.5 Var	6.5 Va	0.72	9 H	4.7 kΩ	7.4 kΩ	4.3 kΩ	1.19	50°
C	Pump	VL1038A0 / A.R.S. – MPP1	185 mA	140 V ~	50 Hz	21 W	30 Var	36 Va	0.58	1.75 H	660 Ω	1.3 kΩ	580 Ω	1.66	59°
E	Fan	VN1162A0 / SUNON – DP200A	130 mA	230 V ~	50 Hz	21 W	19 Var	28 Va	0.75	3.4 H	1.1 kΩ	1.6 kΩ	626 Ω	1.11	48.1°
F	Motor	MT1012A0 / SISME	1.62	240V	60 Hz	388W	-	-	-	-	30.5 kΩ	-	-	-	-
G	DRY.Maxi solenoid	VE1135-VE1140-VE1014 RPE SERIES R	-	230V	50 Hz	-	-	8VA	-	-	-	-	-	-	-

LEGEND	
I	Load current consumption
V	Voltage applied to the load
F	Frequency
P	Load active power
Q	Load reactive power
S	Load apparent power
PF	Power Factor (PF=P/S)
L @ 100Hz	@ 100Hz measured inductance
R @ 100Hz	@ 100Hz measured resistance
Z @ 100Hz	@ 100Hz measured impedance
DCR	Measured resistance in DC
X/R	$Q= X/R $ (X=reactance, R=resistance)
θ	angle between real axis and the impedance vector

► Input

NAME	INPUT DESCRIPTION	INPUT TYPE	RANGE	SENSITIVITY	PRECISION	HARDWARE INPUT
CMB_1	Bottom temperature probe	Analogue PT100	0 – 300 °C	0.1°C	+/- 0.5 °C	√
CMB_2	Top temperature probe	Analogue PT100	0 – 300 °C	0.1°C	+/- 0.5 °C	√
BRD_TEMP	Board temperature probe	Analogue NTC	0 – 100 °C	5°C	+/- 5 °C	
HEART_1	Mono-point core probe	Analogue PT100	0 – 300 °C	1°C	+/- 1 °C	√
TAC_1	Tachometer group 1 (speed)	Analogue	30 – 10K RPM	1 RPM	+/- 1 RPM	√
TAC_2	Tachometer group 2 (direction)	Analogue	30 – 10K RPM	1 RPM	+/- 1 RPM	√
VAC	Power supply alternate current	Analogue	0 – 260 VRMS	1 V	+/- V	
VDC	V DC on modbus	Analogue	0 – 15 V	1 mV	+/- mV	
IDC	DC current	Analogue	0 – 7 A	1 mA	+/- mA	
AC_FREQ	Power supply frequency	Analogue	0 - 50 - 60 Hz	-	-	
DOOR_1	Door switch 1	Digital	-	-	-	√
DOOR_2	Door switch 2 (trolley switch)	Digital	-	-	-	√
ALL_TS	Safety thermostat alarm	Analogue	-	-	-	
ALL_TM	Motor thermal protection	Digital	-	-	-	

► Communication socket

Power board comes with:

- 1 CANUS socket to communicate with the control board (P11)
- 2 CANBUS sockets to communicate with another power board and with a CANBUS-ETHERNET (P12, P13)
- 3 MODBUS sockets to communicate with accessory power board (P8, P9, P10)

► Power supply

PARAMETER	NOMINAL VALUE	MINIMUM VALUE	MAXIMUM VALUE
NETWORK VOLTAGE SUPPLY	230 V _{AC}	180 V _{AC}	270 V _{AC}
NETWORK FREQUENCY SUPPLY	-	50 Hz	60 Hz
PRIMARY TRANSFORMER VOLTAGE	230 V _{AC}	180 V _{AC}	270 V _{AC}
SECONDARY TRANSFORMER VOLTAGE	12 V _{AC}	-	-
SECONDARY TRANSFORMER CURRENT	5 A	-	-
SECONDARY TRANSFORMER 1 CURRENT	4.2 A	-	-
SECONDARY TRANSFORMER 2 CURRENT	83 mA	-	-

► Socket table

N° OF SOCKET	SOCKET TYPE	N° PIN	LABEL	DESCRIPTION
P1	INARLOCK 6P 2F (White)	1	N	Board power supply (neutral)
		2	N_F	Transformer power supply (filtered neutral)
		3	L_F	Transformer power supply (phase)
		4	L	Board power supply (phase)
		5	COND	Capacitor for the motor startup
		6	COND	Capacitor for the motor startup
P2	INARLOCK 5P 1F (Black)	1	N	Neutral
		2	RW	Motor power supply -counterclock wise spinning
		3	FW	Motor power supply -clock wise spinning
		4	F	Phase 230 Vac
		5	TM	Motor thermal protection input
P3	INARLOCK 3P 1F (Black)	1	RES1	Braking element 1
		2		
		2	RES2	Braking element 2
		3		
P4	INARLOCK 6P 1F (White)	1	PD	Detergent pump phase
		2	N	Detergent pump neutral
		3	EL1	Water solenoid valve EL1 phase
		4	N	Water solenoid valve EL1 neutral
		5	VENT	DRY.Maxi phase
		6	N	DRY.Maxi neutral
P5	INARLOCK 3P 1F (White)	1	EV1	EV1 Phase high flow rate
		2	N	Common neutral EV1 and EV2
		3	EV2	EV2 Phase low flow rate
P6	INARLOCK 2P 1F (Black)	1	FAN	Cooling fan phase
		2	N	Cooling fan neutral
P7	INARLOCK 2P 1F (White)	1	ABB	Drainage cooling water solenoid phase
		2	N	Drainage cooling water solenoid neutral

P8	RJ PLUG 8 contacts 90°	1	-	+13V	Accessory board 1 connection (MODBUS)
		2		GND	
		3		A	
		4		B	
		5		+12V	
		6		GND	
		7		GND	
		8		+13V	
P9	RJ PLUG 8 contacts 90°	1	-	+13V	Accessory board 2 connection (MODBUS)
		2		GND	
		3		A	
		4		B	
		5		+13V	
		6		GND	
		7		GND	
		8		+13V	
P10	RJ PLUG 8 contacts 90°	1	-	+13V	Accessory board 3 connection (MODBUS)
		2		GND	
		3		A	
		4		B	
		5		+13V	
		6		GND	
		7		GND	
		8		+13V	
P11	CPM 4P-5P08	1	CONTROL	+13V	Control board connection (CANBUS)
		2		B	
		3		A	
		4		GND	
P12	MOLEX Microfit 4P	1	-	+13V	Bridge board connection (CANBUS)
		2		B	
		3		A	
		4		GND	
P13	MOLEX Microfit 4P	1	-	+13V	Bridge board connection (CANBUS)
		2		B	
		3		A	
		4		GND	
P28	AMP Modu II 6P	1	-	Potential free contact 1	
		2		GND	
		3		Potential free contact 2	
		4		GND	
		5		Potential free contact 3	
		6		GND	
		2			
P15	AMP Modu II 2P	1	-	Single point core probe input	
		2			
P16	JST XHP-2	1	CMB2	IN	Top temperature probe
		2		GND	
P17	MINIFIT 2P	1	DOOR1	IN	Door switch 1 input
		2		GND	
P18	MINIFIT 2P	1	DOOR2	IN	Door switch 2 input (only used in trolley ovens)
		2		GND	
P19	JST XHP-2	1	CMB1	IN	Bottom temperature probe
		2		GND	
P20	AMP Modu II 4P	1	TAC1/2	+13V	Tachometer input TAC1 e TAC2
		2		IN_TAC1	
		3		IN_TAC2	
		4		GND	

► Fuse list

FUSE	NOMINAL CURRENT	NOMINAL VOLTAGE	SPEED OF INTERVENTION	PROTECTED CIRCUIT
F2	2A	250V	Fast (F)	Primary transformer (TR60 230V-12V 60VA)
F3	2A	250V	Fast (F)	Detergent pump (PD output on P4 socket)
F4	4A	250V	Time delay (T)	Secondary transformer (TR60 230V-12V 60VA)

► Mechanical dimensions

DIMENSION X	282 mm
DIMENSION Y	145 mm
MAXIMUM HEIGHT	49 mm
FIXING HOLES DIAMETER	4,06 mm

► Working parameters

PARAMETER	MINIMUM VALUE	MAXIMUM VALUE
WORKING TEMPERATURE	+10 °C	+70 °C
STORAGE TEMPERATURE	-10 °C	+70 °C
WORKING HUMIDITY	-	80%
STORAGE HUMIDITY	-	90%

► Regulations

PE2037A is designed in compliance with the following regulations:

Directive:

low voltage: electromagnetic compatibility: 73/23/CEE
89/336/CEE

General regulations:

electromagnetic compatibility - CEI EN50081-1
emissions: compatibility - CEI EN50082-1
immunity:

PE2038A GENERAL DESCRIPTION

The PE2038A is a circuit board with its main functions being to:

- manage the loads of the oven (contactors, motors, solenoid valve, etc.)
- read the measurements provided by the different sensors (temperature probes, door switch, etc.)
- power the low voltage of the entire system
- communicate through CANBUS with the control board
- communicate through (RS485) with possible bridge boards

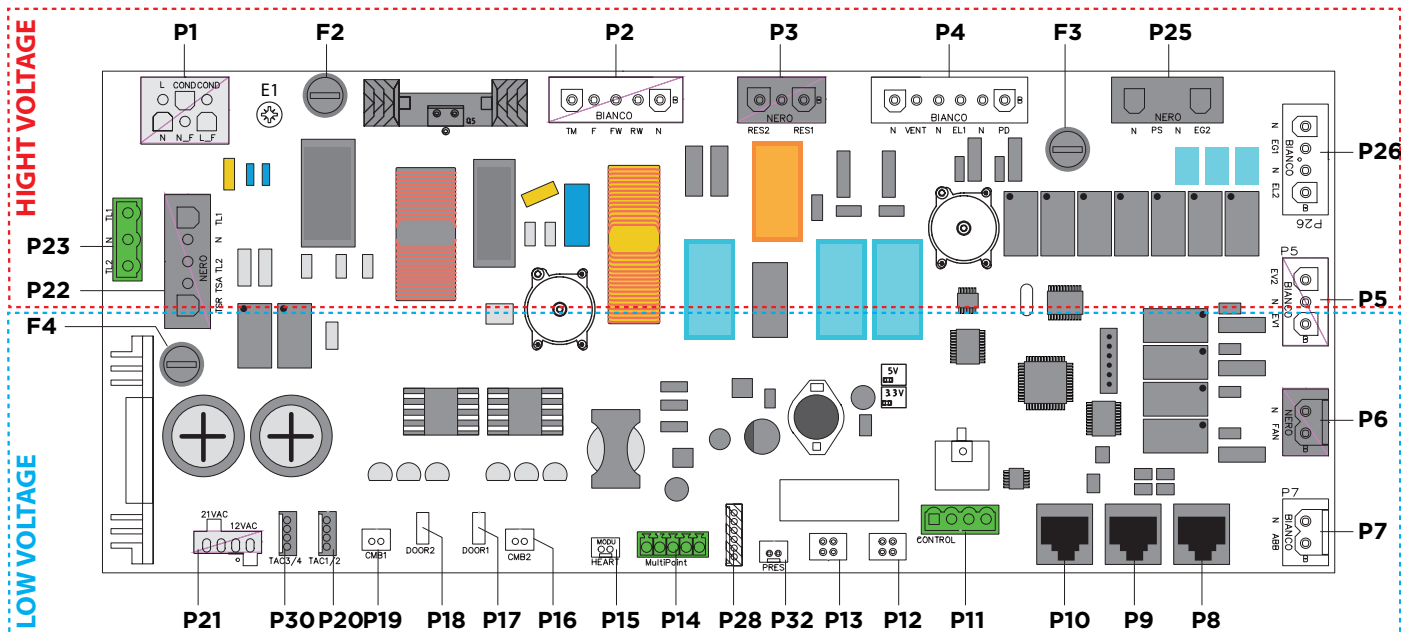

► Output

NAME	LOAD DESCRIPTION	ACTUALIZATION	VOLTAGE	CURRENT (MAX N°LOAD)	TYPE OF LOAD	MAX N° LOAD	HARDWARE OUTPUT
TL_1	67% heating elements branch – contactors	Relay (RL8)	230 Vrms	120 mA	A	4	✓
TL_2	33% heating elements branch – contactors	Relay (RL9)	230 Vrms	120 mA	A	4	✓
EV_1	steam low flow	Relay (RL4)	230 Vrms	60 mA	B	2	✓
EV_2	steam high flow	Relay (RL5)	230 Vrms	60 mA	B	2	✓
VENT	DRY.Maxi solenoid	Relay (RL3)	230 Vrms	35 mA	G	1	✓
PD	Detergent pump	Relay (RL14)	140 Vrms	370 mA	C	2	✓
EL_1	Washing solenoid from tap water	Relay (RL2)	230 Vrms	30 mA	B	1	✓
EL_2	Washing solenoid to 3rd wash arm if fitted	Relay (RL18)	230 Vrms	30 mA	B	1	✓
EG_1	Rotor arm 1 water solenoid	Relay (RL15)	230 Vrms	30 mA	B	1	✓
EG_2	Rotor arm 2 water solenoid	Relay (RL16)	230 Vrms	30 mA	B	1	✓
ABB	Cooling drainage solenoid	Relay (RL7)	230 Vrms	30 mA	B	1	✓
FAN	Cooling fan	Relay (RL6)	230 Vrms	260 mA	E	2	✓
RES_1	Braking element 1	Relay (RL10)	230 Vrms	-	-	5	✓
RES_2	Braking element 2	Relay (RL11)	230 Vrms	-	-	5	✓
MOT_FWRW	Motor revolution direction	Relay (RL12)	-	-	-	-	✓
STBY	Neutral cut off	Relay (RL13)	-	-	-	-	-
DCO_1	13 Vdc auxiliary output	Open collector	13 Vdc	500 mA	-	1	✓
TRIAC	Motor triac control	Triac	230Vrms	8 A	F	5	✓
SR_1	-	-	-	-	-	-	✓
SR_2	-	-	-	-	-	-	✓
SR_T	-	-	-	-	-	-	-

REF.	DESCRIPTION	SUPPLIER	I	V	F	P	Q	S	PF	L @ 100Hz	R @ 100Hz	Z @ 100Hz	DCR	X/R	θ
A	Contacteur	VE1095A0 / GE- CL01A400T	30 mA	230 V ~	50 Hz	2 W	6 Var	6.5 Va	0.31	13 H	2 k Ω	9.4 k Ω	770 Ω	4.42	77.2°
B	Solenoid valve	VE1135A0 / RPE – SERIE R	30 mA	230 V ~	50 Hz	4.7 W	4.5 Var	6.5 Va	0.72	9 H	4.7 k Ω	7.4 k Ω	4.3 k Ω	1.19	50°
C	Pump	VL1038A0 / A.R.S. – MPP1	185 mA	140 V ~	50 Hz	21 W	30 Var	36 Va	0.58	1.75 H	660 Ω	1.3 k Ω	580 Ω	1.66	59°
E	Fan	VN1162A0 / SUNON – DP200A	130 mA	230 V ~	50 Hz	21 W	19 Var	28 Va	0.75	3.4 H	1.1 k Ω	1.6 k Ω	626 Ω	1.11	48.1°
F	Motor	MT1012A0 / SISME	1.62	240V	60 Hz	388W					30.5				
G	DRY.Maxi solenoid	VE1135-VE1140-VE1014 RPE SERIES R		230V	50 Hz			8VA							

LEGEND

I	Load current consumption
V	Voltage applied to the load
F	Frequency
P	Load active power
Q	Load reactive power
S	Load apparent power
PF	Power Factor (PF=P/S)
L @ 100Hz	@ 100Hz measured inductance
R @ 100Hz	@ 100Hz measured resistance
Z @ 100Hz	@ 100Hz measured impedance
DCR	Measured resistance in DC
X/R	$Q= X/R $ (X=reactance, R=resistance)
θ	angle between real axis and the impedance vector

► Input

NAME	INPUT DESCRIPTION	INPUT TYPE	RANGE	SENSITIVITY	PRECISION	HARDWARE INPUT
CMB_1	Bottom temperature probe	Analogue PT100	0 – 300 °C	0.1°C	+/- 0.5 °C	√
CMB_2	Top temperature probe	Analogue PT100	0 – 300 °C	0.1°C	+/- 0.5 °C	√
BRD_TEMP	Board temperature probe	Analogue NTC	0 – 100 °C	5°C	+/- 5 °C	
HEART_1	Single point core probe or 1st multi point core probe point	Analogue PT100	0 – 300 °C	0.1°C	+/- 0.5 °C	√
HEART_2	2nd multi point core probe point	Analogue PT100	0 – 300 °C	0.1°C	+/- 0.5 °C	√
HEART_3	3rd multi point core probe point	Analogue PT100	0 – 300 °C	0.1°C	+/- 0.5 °C	√
HEART_4	4th multi point core probe point	Analogue PT100	0 – 300 °C	0.1°C	+/- 0.5 °C	√
TAC_1	Tachometer group 1 (speed)	Analogue	30 – 10K RPM	1 RPM	+/- 1 RPM	√
TAC_2	Tachometer group 2 (direction)	Analogue	30 – 10K RPM	1 RPM	+/- 1 RPM	√
VAC	Power supply alternate current	Analogue	0 – 260 V _{RMS}	1 V	+/- 5 V	
IAC_MOT	Motor power supply alternate current	Analogue	0 - 8 A _{RMS}	1 mA _{RMS}	+/- 50 mA _{RMS}	
IAC_LOAD	Auxiliary loads power supply alternate current	Analogue	0 - 1.5 A _{RMS}	1 mA _{RMS}	+/- 5 mA _{RMS}	
VDC	V DC on modbus	Analogue	0 – 15 V	1 mV	+/- 20mV	
IDC	DC current	Analogue	0 – 7 A	1 mA	+/- 5mA	
AC_FREQ	Power supply frequency	Analogue	0 - 50 - 60 Hz	-	-	
MOTDIR_1	Motor revolution direction (TAC1-TAC2)	Digital	-	-	-	
MOTDIR_2	Motor revolution direction (TAC3-TAC4)	Digital	-	-	-	
DOOR_1	Door switch 1	Digital	-	-	-	√
DOOR_2	Door switch 2 (trolley switch)	Digital	-	-	-	√
ALL_TS	Safety thermostat alarm	Analogue	-	-	-	
ALL_TM	Motor thermal protection	Digital	-	-	-	
INCP_1	Potential free contact 1	Digital	-	-	-	√
INCP_2	Potential free contact 2	Digital	-	-	-	√
INCP_3	Potential free contact 3	Digital	-	-	-	√
IN_PRES	Pressure switch	Digital	-	-	-	√

► Communication socket

Power board comes with:

- 1 CANUS socket to communicate with the control board (P11)

- 2 CANBUS sockets to communicate with another power board and with a CANBUS-ETHERNET (P12, P13)
- 3 MODBUS sockets to communicate with accessory power board (P8, P9, P10)

► Power supply

PARAMETER	NOMINAL VALUE	MINIMUM VALUE	MAXIMUM VALUE
NETWORK VOLTAGE SUPPLY	230 V _{AC}	180 V _{AC}	270 V _{AC}
NETWORK FREQUENCY SUPPLY	-	50 Hz	60 Hz
PRIMARY TRANSFORMER VOLTAGE	230 V _{AC}	180 V _{AC}	270 V _{AC}
SECONDARY TRANSFORMER 1 VOLTAGE	21 V ~	-	-
SECONDARY TRANSFORMER 2 VOLTAGE	12 V ~	-	-
SECONDARY TRANSFORMER 1 CURRENT	4.2 A	-	-
SECONDARY TRANSFORMER 2 CURRENT	83 mA	-	-

► Socket table

N° OF SOCKET	SOCKET TYPE	N° PIN	LABEL	DESCRIPTION
P1	INARLOCK 6P 2F (White)	1	N	Board power supply (neutral)
		2	N_F	Transformer power supply (filtered neutral)
		3	L_F	Transformer power supply (phase)
		4	L	Board power supply (phase)
		5	COND	Capacitor for the motor startup
		6	COND	Capacitor for the motor startup
P2	INARLOCK 5P 1F (Black)	1	N	Neutral
		2	RW	Motor power supply -counterclock wise spinning
		3	FW	Motor power supply -clock wise spinning
		4	F	Phase 230 Vac
		5	TM	Motor thermal protection input
P3	INARLOCK 3P 1F (Black)	1	RES1	Braking element 1
		2		
		2	RES2	Braking element 2
		3		
P4	INARLOCK 6P 1F (White)	1	PD	Detergent pump phase
		2	N	Detergent pump neutral
		3	EL1	Water solenoid valve EL1 phase
		4	N	Water solenoid valve EL1 neutral
		5	VENT	DRY.Maxi phase
		6	N	DRY.Maxi neutral
P25	INARLOCK 4P 1F (Black)	1	EG2	EG2 solenoid phase
		2	N	EG2 solenoid neutral
		3	PS	-
		4	N	-

P26	INARLOCK 4P 1F (White)	1	EL2	EL2 solenoid phase	
		2	N	EL2 solenoid neutral	
		3	EG1	EG1 solenoid phase	
		4	N	EG1 solenoid neutral	
P5	INARLOCK 3P 1F (White)	1	EV1	EV1 Phase high flow rate	
		2	N	Common neutral EV1 and EV2	
		3	EV2	EV2 Phase low flow	
P6	INARLOCK 2P 1F (Black)	1	FAN	Cooling fan phase	
		2	N	Cooling fan neutral	
P7	INARLOCK 2P 1F (White)	1	ABB	Drainage cooling water solenoid phase	
		2	N	Drainage cooling water solenoid neutral	
P8	RJ PLUG 8 contacts 90°	1	-	+13V	Accessory board 1 connection (MODBUS)
		2		GND	
		3		A	
		4		B	
		5		+12V	
		6		GND	
		7		GND	
		8		+13V	
P9	RJ PLUG 8 contacts 90°	1	-	+13V	Accessory board 2 connection (MODBUS)
		2		GND	
		3		A	
		4		B	
		5		+13V	
		6		GND	
		7		GND	
		8		+13V	
P10	RJ PLUG 8 contacts 90°	1	-	+13V	Accessory board 3 connection (MODBUS)
		2		GND	
		3		A	
		4		B	
		5		+13V	
		6		GND	
		7		GND	
		8		+13V	
P11	CPM 4P-5P08	1	CONTROL	+13V	Control board connection (CANBUS)
		2		B	
		3		A	
		4		GND	
P12	MOLEX Microfit 4P	1	-	+13V	Bridge board connection (CANBUS)
		2		B	
		3		A	
		4		GND	
P13	MOLEX Microfit 4P	1	-	+13V	Bridge board connection (CANBUS)
		2		B	
		3		A	
		4		GND	

P28	AMP Modu II 6P	1	-	Potential free contact 1	
		2		GND	
		3		Potential free contact 2	
		4		GND	
		5		Potential free contact 3	
		6		GND	
		2			
P14	CPM-5P-3P81	1	MultiPoint	IN1	Multi point core probe input
		2		IN2	
		3		IN3	
		4		IN4	
		5		GND	
P15	AMP Modu II 2P	1	-	Single point core probe input	
		2			
P16	JST XHP-2	1	CMB2	IN	Top temperature probe
		2		GND	
P17	MINIFIT 2P	1	DOOR1	IN	Door switch 1 input
		2		GND	
P18	MINIFIT 2P	1	DOOR2	IN	Door switch 2 input (only used in trolley ovens)
		2		GND	
P19	JST XHP-2	1	CMB1	IN	Bottom temperature probe
		2		GND	
P20	AMP Modu II 4P	1	TAC1/2	+13V	Tachometer input TAC1 e TAC2
		2		IN_TAC1	
		3		IN_TAC2	
		4		GND	
P30	AMP Modu II 4P	1	TAC3/4	+13V	Tachometer input TAC3 e TAC4
		2		IN_TAC3	
		3		IN_TAC4	
		4		GND	
P21	MOLEX Minifit 4P	1	21VAC	21V ac	21 V AC power supply from secondary transformer
		2		21V ac	
		3	12VAC	12V ac	12 V AC power supply from secondary transformer
		4		12V ac	
P22	INARLOCK 5P 1F (Black)	1	TL1	High-Power contactor phase	
		2	N	TL1 e TL2 neutral	
		3	TL2	Low-Power contactor phase	
		4	TSA	Safety thermostat output	
		5	TSR	Safety thermostat return	
P31	MOLEX Microfit 6P	1	-	+13V	-
		2		SR1	
		3		+13V	-
		4		SR2	
		5		+13V	-
		6		GND	
P32	JST XHP-2	1	PRES	IN	Pressure switch potential free input
		2		GND	GND
P24	MOLEX Microfit 6P	1 ÷ 6	-	-	
E1	fixing screw	1	E1	Ground connection	

► Fuse list

FUSE	NOMINAL CURRENT	NOMINAL VOLTAGE	SPEED OF INTERVENTION	PROTECTED CIRCUIT
F2	2A	250V	Fast (F)	Primary transformer (TR60 230V-12V 60VA)
F3	2A	250V	Fast (F)	Detergent pump (PD output on P4 socket)
F4	4A	250V	Time delay	Secondary transformer (TR60 230V-12V 60VA)

► Mechanical dimension

DIMENSION X	356 mm
DIMENSION Y	145 mm
MAXIMUM HEIGHT	49 mm
FIXING HOLES DIAMETER	4,06 mm

► Working parameter

PARAMETER	MINIMUM VALUE	MAXIMUM VALUE
WORKING TEMPERATURE	+10 °C	+70 °C
STORAGE TEMPERATURE	-10 °C	+70 °C
WORKING HUMIDITY	-	80%
STORAGE HUMIDITY	-	90%

► Regulations

PE2038A is designed in compliance with the following regulations:

Directive:

low voltage: 73/23/CEE
 electromagnetic compatibility: 89/336/CEE

General regulations:

electromagnetic compatibility - emissions: CEI EN50081-1
 electromagnetic compatibility - immunity: CEI EN50082-1

PE2021C GENERAL DESCRIPTION

The PE2021C is a circuit board with its main functions being to:

- manage the load of the oven (contactors, motors, solenoid valve, etc.)
- read the measurement provided by the different sensors (temperature probes, door switch, etc.)
- power the low voltage of the entire system
- communicate through CANBUS with the control board
- communicate through (RS485) with possible bridge boards

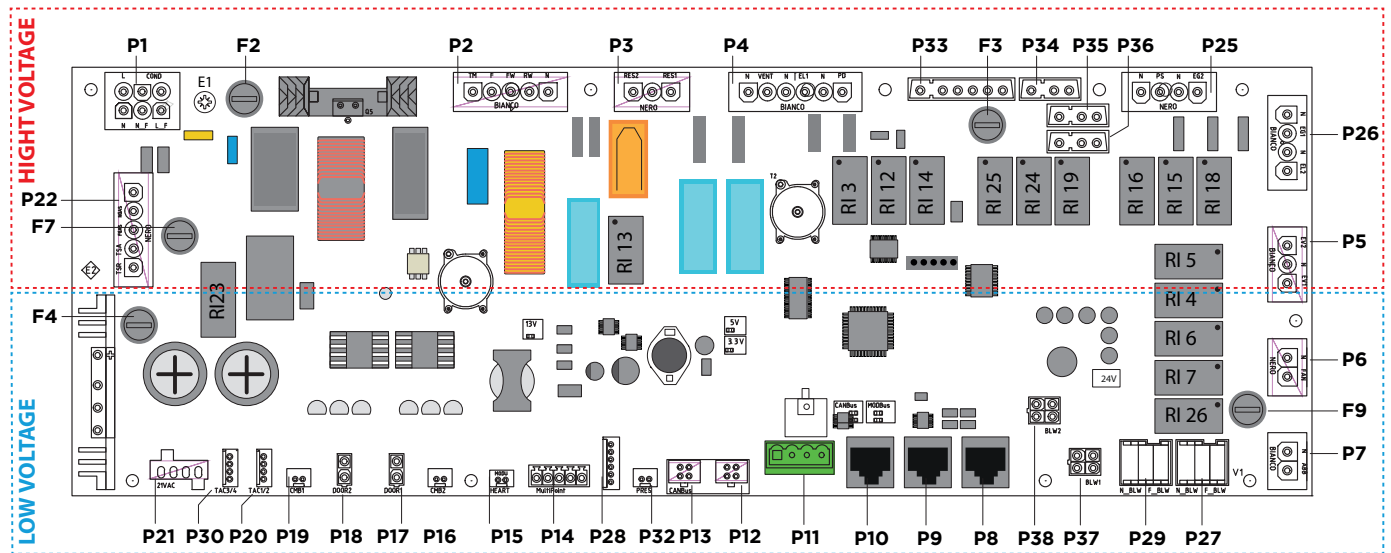

► Output

NAME	LOAD DESCRIPTION	ACTUALIZATION	VOLTAGE	CURRENT (MAX N°LOAD)	TYPE OF LOAD	MAX N° LOAD	HARDWARE OUTPUT
EV_1	steam low flow rate	Relay (RL4)	230 Vrms	60 mA	B	2	✓
EV_2	steam high flow rate	Relay (RL5)	230 Vrms	60 mA	B	2	✓
VENT	DRY.Maxy solenoid	Relay (RL3)	230 Vrms	35 mA	G	1	✓
PD	Detergent pump	Relay (RL14)	230 Vrms	370 mA	C	2	✓
EL_1	Washing solenoid from tap water	Relay (RL2)	230 Vrms	30 mA	B	1	✓
EL_2	Washing solenoid to 3rd wash arm if fitted	Relay (RL18)	230 Vrms	30 mA	B	1	✓
EG_1	Rotor arm 1 water solenoid	Relay (RL15)	230 Vrms	30 mA	B	1	✓
EG_2	Rotor arm 2 water solenoid	Relay (RL16)	230 Vrms	30 mA	B	1	✓
ABB	Cooling drainage solenoid	Relay (RL7)	230 Vrms	30 mA	B	1	✓
FAN	Cooling fan	Relay (RL6)	230 Vrms	260 mA	E	2	✓
RES_1	Braking element 1	Relay (RL10)	230 Vrms	-	-	5	✓
RES_2	Braking element 2	Relay (RL11)	230 Vrms	-	-	5	✓
MOT_FWRW	Motor revolution direction	Relay (RL12)	-	-	-	-	✓

STBY	neutral cut off	Relay (RL1)	-	-	-	-	-	-	-	-	-	-	-	-	-
DCO_1	13 Vdc auxiliary output	-	13 Vdc	500 mA	-	1	√								
TRIAC	Motor triac control	Relay (RL13)	230Vrms	8 A	F	5	√								
SR_1	Brahma Circuit	Relay (RL25) (Dry Contact)	-	-	-	-	√								
SR_2	Brahma Circuit	Relay (RL24) (Dry Contact)	-	-	-	-	√								
BLW	Blower	Relay (RL26)	230Vrms	-	-	-	√								

REF.	DESCRIPTION	SUPPLIER	I	V	F	P	Q	S	PF	L @ 100Hz	R @ 100Hz	Z @ 100Hz	DCR	X/R	θ
A	Contactora	VE1095A0 / GE- CL01A400T	30 mA	230 V ~	50 Hz	2 W	6 Var	6.5 Va	0.31	13 H	2 kΩ	9.4 kΩ	770 Ω	4.42	77.2°
B	Solenoid valve	VE1135A0 / RPE – SERIES R	30 mA	230 V ~	50 Hz	4.7 W	4.5 Var	6.5 Va	0.72	9 H	4.7 kΩ	7.4 kΩ	4.3 kΩ	1.19	50°
C	Pump	VL1038A0 / A.R.S. – MPPI	185 mA	140 V ~	50 Hz	21 W	30 Var	36 Va	0.58	1.75 H	660 Ω	1.3 kΩ	580 Ω	1.66	59°
E	Fan	VN1162A0 / SUNON – DP200A	130 mA	230 V ~	50 Hz	21 W	19 Var	28 Va	0.75	3.4 H	1.1 kΩ	1.6 kΩ	626 Ω	1.11	48.1°
F	Motor	MT1012A0 / SISME	1.62	240V	60 Hz	388W					30.5 kΩ				
G	DRY.Maxi solenoid	VE1135-VE1140- VE1014 RPE SERIES R		230V	50 Hz			8VA							

LEGEND	
I	Load current consumption
V	Voltage applied to the load
F	Frequency
P	Load active power
Q	Load reactive power
S	Load apparent power
PF	Power Factor (PF=P/S)
L @ 100Hz	@ 100Hz measured inductance
R @ 100Hz	@ 100Hz measured resistance
Z @ 100Hz	@ 100Hz measured impedance
DCR	Measured resistance in DC
X/R	$Q= X/R $ (X=reactance, R=resistance)
θ	Angle between real axis and the impedance vector

► Input

NAME	INPUT DESCRIPTION	INPUT TYPE	RANGE	SENSITIVITY	PRECISION	HARDWARE INPUT
CMB_1	Bottom temperature probe	Analogue PT100	0 – 300 °C	0.1°C	+/- 0.5 °C	√
CMB_2	Top temperature probe	Analogue PT100	0 – 300 °C	0.1°C	+/- 0.5 °C	√
BRD_TEMP	Board temperature probe	Analogue NTC	0 – 100 °C	5°C	+/- 5 °C	
HEART_1	Single point core probe or 1st multi point core probe point	Analogue PT100	0 – 300 °C	0.1°C	+/- 0.5 °C	√
HEART_2	2nd multi point core probe point	Analogue PT100	0 – 300 °C	0.1°C	+/- 0.5 °C	√
HEART_3	3rd multi point core probe point	Analogue PT100	0 – 300 °C	0.1°C	+/- 0.5 °C	√
HEART_4	4th multi point core probe point	Analogue PT100	0 – 300 °C	0.1°C	+/- 0.5 °C	√
TAC_1	Tachometer group 1 (speed)	Analogue	30 – 10K RPM	1 RPM	+/- 1 RPM	√
TAC_2	Tachometer group 2 (direction)	Analogue	30 – 10K RPM	1 RPM	+/- 1 RPM	√
VAC	Power supply alternate current	Analogue	0 – 260 V _{RMS}	1 V	+/- 5 V	
IAC_MOT	Motor power supply alternate current	Analogue	0 - 8 A _{RMS}	1 mA _{RMS}	+/- 50 mA _{RMS}	
IAC_LOAD	Auxiliary loads power supply alternate current	Analogue	0 - 1.5 A _{RMS}	1 mA _{RMS}	+/- 5 mA _{RMS}	
VDC	V DC on modbus	Analogue	0 – 15 V	1 mV	+/- 20mV	
IDC	DC current	Analogue	0 – 7 A	1 mA	+/- 5mA	
AC_FREQ	Power supply frequency	Analogue	0 - 50 - 60 Hz	-	-	
MOTDIR_1	Motor revolution direction (TAC1-TAC2)	Digital	-	-	-	
MOTDIR_2	Motor revolution direction (TAC3-TAC4)	Digital	-	-	-	
DOOR_1	Door switch 1	Digital	-	-	-	√
DOOR_2	Door switch 2 (trolley switch)	Digital	-	-	-	√
ALL_TS	Safety thermostat alarm	Analogue	-	-	-	
ALL_TM	Motor thermal protection	Digital	-	-	-	
INCP_1	Potential free contact 1	Digital	-	-	-	√
INCP_2	Potential free contact 2	Digital	-	-	-	√
INCP_3	Potential free contact 3	Digital	-	-	-	√
IN_PRES	Pressure switch	Digital	-	-	-	√

► Communication socket

Power board comes with:

- 1 CANUS socket to communicate with the control board (P11)
- 2 CANBUS sockets to communicate with another power board and with a CANBUS-ETHERNET (P12, P13)
- 3 MODBUS sockets to communicate with accessory power board (P8, P9, P10)

► Power supply

PARAMETER	NOMINAL VALUE	MINIMUM VALUE	MAXIMUM VALUE
NETWORK VOLTAGE SUPPLY	230 V _{AC}	180 V _{AC}	270 V _{AC}
NETWORK FREQUENCY SUPPLY	-	50 Hz	60 Hz
PRIMARY TRANSFORMER VOLTAGE	230 V _{AC}	180 V _{AC}	270 V _{AC}
SECONDARY TRANSFORMER 1 VOLTAGE	21 V ~	-	-
SECONDARY TRANSFORMER 2 VOLTAGE	12 V ~	-	-
SECONDARY TRANSFORMER 1 CURRENT	4.2 A	-	-
SECONDARY TRANSFORMER 2 CURRENT	83 mA	-	-

► Socket table

N° OF SOCKET	SOCKET TYPE	N° PIN	LABEL	DESCRIPTION
P1	INARLOCK 6P 2F (White)	1	N	Board power supply (neutral)
		2	N_F	Transformer power supply (filtered neutral)
		3	L_F	Transformer power supply (phase)
		4	L	Board power supply (phase)
		5	COND	Capacitor for the motor startup
		6	COND	Capacitor for the motor startup
P2	INARLOCK 5P 1F (Black)	1	N	Neutral
		2	RW	Motor power supply -counterclock wise spinning
		3	FW	Motor power supply -clock wise spinning
		4	F	Phase 230 Vac
		5	TM	Motor thermal protection input
P3	INARLOCK 3P 1F (Black)	1	RES1	Braking element 1
		2		
		3	RES2	Braking element 2
P4	INARLOCK 6P 1F (White)	1	PD	Detergent pump phase
		2	N	Detergent pump neutral
		3	EL1	Water solenoid valve EL1 phase
		4	N	Water solenoid valve EL1 neutral
		5	VENT	DRY.Maxi phase
		6	N	DRY.Maxi output neutral

P25	INARLOCK 4P 1F (Black)	1	EG2	EG2 solenoid phase	
		2	N	EG2 solenoid neutral	
		3	PS	-	
		4	N	-	
P26	INARLOCK 4P 1F (White)	1	EL2	EL2 solenoid phase	
		2	N	EL2 solenoid neutral	
		3	EG1	EG1 solenoid phase	
		4	N	EG1 solenoid neutral	
P5	INARLOCK 3P 1F (White)	1	EV1	EV1 Phase low flow rate	
		2	N	Common neutral output EV1 and EV2	
		3	EV2	EV2 Phase high flow rate	
P6	INARLOCK 2P 1F (Black)	1	FAN	Cooling fan phase	
		2	N	Cooling fan neutral	
P7	INARLOCK 2P 1F (White)	1	ABB	Drainage cooling water solenoid phase	
		2	N	Drainage cooling water solenoid neutral	
P8	RJ PLUG 8 contacts 90°	1	-	+13V	Accessory board 1 connection (MODBUS)
		2		GND	
		3		A	
		4		B	
		5		+12V	
		6		GND	
		7		GND	
		8		+13V	
P9	RJ PLUG 8 contacts 90°	1	-	+13V	Accessory board 2 connection (MODBUS)
		2		GND	
		3		A	
		4		B	
		5		+13V	
		6		GND	
		7		GND	
		8		+13V	
P10	RJ PLUG 8 contacts 90°	1	-	+13V	Accessory board 3 connection (MODBUS)
		2		GND	
		3		A	
		4		B	
		5		+13V	
		6		GND	
		7		GND	
		8		+13V	
P11	CPM 4P-5P08	1	CONTROL	+13V	Control board connection (CANBUS)
		2		B	
		3		A	
		4		GND	
P12	MOLEX Microfit 4P	1	-	+13V	Bridge board connection (CANBUS)
		2		B	
		3		A	
		4		GND	

P13	MOLEX Microfit 4P	1	-	+13V	Bridge board connection (CANBUS)
		2		B	
		3		A	
		4		GND	
P28	AMP Modu II 6P	1	-	Potential free contact 1	
		2		GND	
		3		Potential free contact 2	
		4		GND	
		5		Potential free contact 3	
		6		GND	
		2			
P14	CPM-5P-3P81	1	MultiPoint	IN1	Multi point core probe input
		2		IN2	
		3		IN3	
		4		IN4	
		5		GND	
P15	AMP Modu II 2P	1	-	Single point core probe input	
		2			
P16	JST XHP-2	1	CMB2	IN	Top temperature probe
		2		GND	
P17	MINIFIT 2P	1	DOOR1	IN	Door switch 1 input
		2		GND	
P18	MINIFIT 2P	1	DOOR2	IN	Door switch 2 input (only used in trolley ovens)
		2		GND	
P19	JST XHP-2	1	CMB1	IN	Bottom temperature probe
		2		GND	
P20	AMP Modu II 4P	1	TAC1/2	+13V	Tachometer input TAC1 e TAC2
		2		IN_TAC1	
		3		IN_TAC2	
		4		GND	
P30	AMP Modu II 4P	1	TAC3/4	+13V	Tachometer input TAC3 e TAC4
		2		IN_TAC3	
		3		IN_TAC4	
		4		GND	
P21	MOLEX Minifit 4P	1	21VAC	21V ac	21 V AC power supply from secondary transformer
		2		21V ac	
		3	12VAC	12V ac	12 V AC power supply from secondary transformer
		4		12V ac	
P22	INARLOCK 5P 1F (Black)	1	TL1	High-Power contactor phase	
		2	N	TL1 and TL2 neutral	
		3	TL2	Low-Power contactor phase	
		4	TSA	Safety thermostat output	
		5	TSR	Safety thermostat return	

P31	MOLEX Microfit 6P	1	-	+13V	-
		2		SR1	
		3		+13V	-
		4		SR2	
		5		+13V	-
		6		GND	
P32	JST XHP-2	1	PRES	IN	Pressure switch potential free input
		2		GND	GND
P24	MOLEX Microfit 6P	1 ÷ 6	-	-	
E1	Fixing screws	1	E1	Ground connection	

► Fuse list

FUSE	NOMINAL CURRENT	NOMINAL VOLTAGE	SPEED OF INTERVENTION	PROTECTED CIRCUIT
F2	2A	250 V	Fast (F)	Primary transformer (TR60 230V-12V 60VA)
F3	2A	250 V	Fast (F)	Detergent pump (PD output on P4 socket)
F4	4A	250 V	Time delay (T)	Secondary transformer (TR60 230V-12V 60VA)
F7	2A	250 V	Fast (F)	Gas control unit BRAHMA ECM113
F9	2A	250 V	Fast (F)	Blower gas premix

► Mechanical dimension

DIMENSION X	356 mm
DIMENSION Y	145 mm
MAXIMUM HEIGHT	49 mm
FIXING HOLES DIAMETER	4,06 mm

► Working parameter

PARAMETER	MINIMUM VALUE	MAXIMUM VALUE
WORKING TEMPERATURE	+10 °C	+70 °C
STORAGE TEMPERATURE	-10 °C	+70 °C
WORKING HUMIDITY	-	80%
STORAGE HUMIDITY	-	90%

► Regulations

The PE2021C board has been designed and built in order to fulfill the following legislation:

Reference Guidelines:

low voltage: 73/23/CEE
 electromagnetic compatibility: 89/336/CEE

General reference rule:

electromagnetic compatibility - emission: CEI EN50081-1
 electromagnetic compatibility - immunity: CEI EN50082-1

PE2022A GENERAL DESCRIPTION

The main function of the PE2022A circuit board is to:

- manage the load of the oven (contactors, motors (max 5 motors), solenoid valve, etc.)
- read the measurement provided by the different sensors (temperature probes, door switch, etc.)
- manage two Brahma TGRD61 gas control unit
- manage 2 blowers for air-gas premix
- power the low voltage of the entire system
- communicate through CANBUS with the control board
- communicate through (RS485) with possible bridge boards

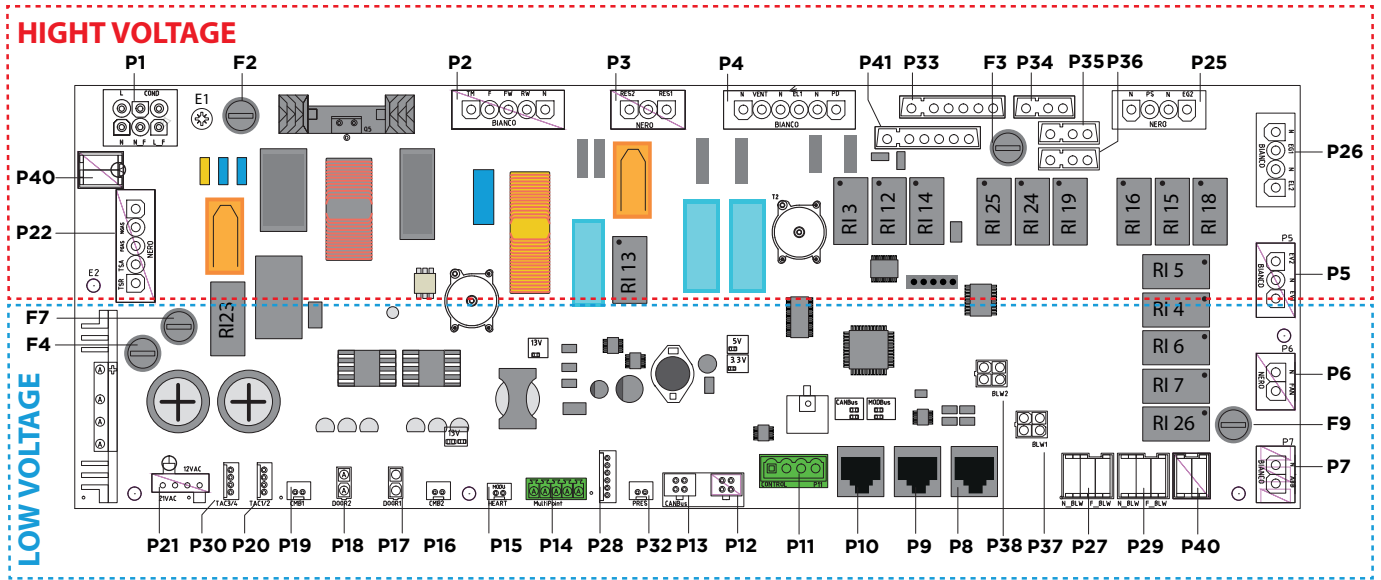

► Output

NAME	LOAD DESCRIPTION	ACTUALIZATION	VOLTAGE	CURRENT (MAX N°LOAD)	TYPE OF LOAD	MAX N° LOAD	HARDWARE OUTPUT
EV_1	steam low flow rate	Relay (RL4)	230 Vrms	60 mA	B	1	✓
EV_2	steam high flow rate	Relay (RL5)	230 Vrms	60 mA	B	1	✓
VENT	DRY.Maxy solenoid	Relay (RL3)	230 Vrms	35 mA	G	1	✓
PD	Detergent pump	Relay (RL14)	140 Vrms	370 mA	C	2	✓
EL_1	Washing solenoid from tap water	Relay (RL2)	230 Vrms	30 mA	B	1	✓
EL_2	Washing solenoid to 3rd wash arm if fitted	Relay (RL18)	230 Vrms	30 mA	B	1	✓
EG_1	Rotor arm 1 water solenoid	Relay (RL15)	230 Vrms	30 mA	B	1	✓
EG_2	Rotor arm 2 water solenoid	Relay (RL16)	230 Vrms	30 mA	B	1	✓
ABB	Cooling drainage solenoid	Relay (RL7)	230 Vrms	30 mA	B	1	✓
FAN	Cooling fan	Relay (RL6)	230 Vrms	260 mA	E	2	✓
RES_1	Braking element 1	Relay (RL10)	230 Vrms	-	-	-	✓
RES_2	Braking element 2	Relay (RL11)	230 Vrms	-	-	-	✓

MOT_FWRW	Motor revolution direction	Relay (RL12)	-	-	-	-	√
STBY	neutral cut off	Relay (RL13)	-	-	-	-	
TRIAC	Motor triac control	-	230Vrms	8 A	F	5	√
PWR_ON_GAS	230 Vac feeding of gas control unit	Relay (RL23)	120 Vrms	-	H	1	√
RESET_GAS	Gas control unit reset	Relay (RL25) (Dry Contact)		-	-	-	√
HD_GAS	Heat demand of gas control unit	Relay (RL24) (Dry Contact)		-	-	-	√
PWR_ON_BLW	230 V ac premix fan	Relay (RL26)	120 Vrms	-	I	1	√
RPM_BLW_1	Premix fun speed 1	-	-	-	-	-	-
RPM_BLW_2	Premix fun speed 2	-	-	-	-	-	-

REF.	DESCRIPTION	SUPPLIER	I	V	F	P	Q	S	PF	L @ 100Hz	R @ 100Hz	Z @ 100Hz	DCR	X/R	θ
A	Contactor	VE1095A0 / GE- CL01A400T	30 mA	230 V ~	50 Hz	2 W	6 Var	6.5 Va	0.31	13 H	2 kΩ	9.4 kΩ	770 Ω	4.42	77.2°
B	Solenoid valve	VE1135A0 / RPE – SERIES R	30 mA	230 V ~	50 Hz	4.7 W	4.5 Var	6.5 Va	0.72	9 H	4.7 kΩ	7.4 kΩ	4.3 kΩ	1.19	50°
C	Pump	VL1038A0 / A.R.S. – MPP1	185 mA	140 V ~	50 Hz	21 W	30 Var	36 Va	0.58	1.75 H	660 Ω	1.3 kΩ	580 Ω	1.66	59°
E	Fan	VN1162A0 / SUNON – DP200A	130 mA	230 V ~	50 Hz	21 W	19 Var	28 Va	0.75	3.4 H	1.1 kΩ	1.6 kΩ	626 Ω	1.11	48.1°
F	Motore	MT1012A0 / SISME)	1.62	240V	60 Hz	388W					30.5				
G	DRY.Maxi solenoid	VE1135-VE1140-VE1014 RPE SERIES R		230V	50 Hz			8VA							
H	Control gas unit	BRAHMA TGRD61		120 V	60 Hz		35 VA								
I	Centrifugal Blower	EBM NGR118		120 V	60 Hz	61W									

LEGEND	
I	Load current consumption
V	Voltage applied to the load
F	Frequency
P	Load active power
Q	Load reactive power
S	Load apparent power
PF	Power Factor (PF=P/S)
L @ 100Hz	@ 100Hz measured inductance
R @ 100Hz	@ 100Hz measured resistance
Z @ 100Hz	@ 100Hz measured impedance
DCR	Measured resistance in DC
X/R	$Q= X/R $ (X=reactance, R=resistance)
θ	Angle between the real axis and the vector that represents the impedance

► Input

NAME	INPUT DESCRIPTION	INPUT TYPE	RANGE	SENSITIVITY	PRECISION	HARDWARE INPUT
CMB_1	Bottom temperature probe	Analogue PT100	0 – 300 °C	0.1°C	+/- 0.5 °C	√
CMB_2	Top temperature probe	Analogue PT100	0 – 300 °C	0.1°C	+/- 0.5 °C	√
BRD_TEMP	Board temperature probe	Analogue NTC	0 – 100 °C	5°C	+/- 5 °C	
HEART_1	Single point core probe or 1st multi point core probe point	Analogue PT100	0 – 300 °C	0.1°C	+/- 0.5 °C	√
HEART_2	2nd multi point core probe point	Analogue PT100	0 – 300 °C	0.1°C	+/- 0.5 °C	√
HEART_3	3rd multi point core probe point	Analogue PT100	0 – 300 °C	0.1°C	+/- 0.5 °C	√
HEART_4	4th multi point core probe point	Analogue PT100	0 – 300 °C	0.1°C	+/- 0.5 °C	√
TAC_1	Tachometer group 1 (speed)	Analogue	30 – 10K RPM	1 RPM	+/- 1 RPM	√
TAC_2	Tachometer group 2 (direction)	Analogue	30 – 10K RPM	1 RPM	+/- 1 RPM	√
VAC	Power supply alternate current	Analogue	0 – 260 V _{RMS}	1 V	+/- 5 V	
IAC_MOT	Motor power supply alternate current	Analogue	0 - 8 A _{RMS}	1 mA _{RMS}	+/- 50 mA _{RMS}	
IAC_LOAD	Auxiliary loads power supply alternate current	Analogue	0 - 1.5 A _{RMS}	1 mA _{RMS}	+/- 5 mA _{RMS}	
VDC	V DC on modbus	Analogue	0 – 15 V	1 mV	+/- 20mV	
IDC	DC current	Analogue	0 – 7 A	1 mA	+/- 5mA	
AC_FREQ	Power supply frequency	Analogue	0 - 50 - 60 Hz	-	-	
MOTDIR_1	Motor revolution direction (TAC1-TAC2)	Digital	-	-	-	
MOTDIR_2	Motor revolution direction (TAC3-TAC4)	Digital	-	-	-	
DOOR_1	Door switch 1	Digital	-	-	-	√
DOOR_2	Door switch 2 (trolley switch)	Digital	-	-	-	√
ALL_TS	Safety thermostat alarm	Analogue	-	-	-	
ALL_TM	Motor thermal protection	Digital	-	-	-	
INCP_1	Potential free contact 1	Digital	-	-	-	√
INCP_2	Potential free contact 2	Digital	-	-	-	√
INCP_3	Potential free contact 3	Digital	-	-	-	√
IN_PRES	Pressure switch	Digital	-	-	-	√
EV_GAS	Gas Valve feeding	Digital	-	-	-	√
TAC_BLW_1	Premix blower tachimetric 1	Analogue	30 – 10K RPM	1 RPM	+/- 1 RPM	√
TAC_BLW_2	Premix blower tachimetric 2	Analogue	30 – 10K RPM	1 RPM	+/- 1 RPM	√

► Communication socket

Power board comes with:

- 1 CANUS socket to communicate with the control board (P11)
- 2 CANBUS sockets to communicate with another power board and with a CANBUS-ETHERNET (P12, P13)
- 3 MODBUS doors to communicate with accessory power board (P8, P9, P10)

► Power supply

PARAMETER	NOMINAL VALUE	MINIMUM VALUE	MAXIMUM VALUE
NETWORK VOLTAGE SUPPLY	230 V _{AC}	180 V _{AC}	270 V _{AC}
NETWORK FREQUENCY SUPPLY	-	50 Hz	60 Hz
PRIMARY TRANSFORMER VOLTAGE	230 V _{AC}	180 V _{AC}	270 V _{AC}
SECONDARY TRANSFORMER 1 VOLTAGE	21 V ~	-	-
SECONDARY TRANSFORMER 2 VOLTAGE	12 V ~	-	-
SECONDARY TRANSFORMER 1 CURRENT	4.2 A	-	-
SECONDARY TRANSFORMER 2 CURRENT	83 mA	-	-

► Socket table

N° OF SOCKET	SOCKET TYPE	N° PIN	LABEL	DESCRIPTION
P1	INARLOCK 6P 2F (White)	1	N	Board power supply (neutral)
		2	N_F	Transformer power supply (filtered neutral)
		3	L_F	Transformer power supply (phase)
		4	L	Board power supply (phase)
		5	COND	Capacitor for the motor startup
		6	COND	Capacitor for the motor startup
P2	INARLOCK 5P 1F (Black)	1	N	Neutral
		2	RW	Motor power supply -counterclock wise spinning
		3	FW	Motor power supply -clock wise spinning
		4	F	Phase 230 Vac
		5	TM	Motor thermal protection input
P3	INARLOCK 3P 1F (Black)	1	RES1	Braking element 1
		2		
		2	RES2	Braking element 2
		3		
P4	INARLOCK 6P 1F (White)	1	PD	Detergent pump phase
		2	N	Detergent pump neutral
		3	EL1	Water solenoid valve EL1 phase
		4	N	Water solenoid valve EL1 neutral
		5	VENT	DRY.Maxi phase
		6	N	DRY.Maxi neutral

P25	INARLOCK 4P 1F (Black)	1	EG2	EG2 solenoid phase	
		2	N	EG2 solenoid neutral	
		3	PS	-	
		4	N	-	
P26	INARLOCK 4P 1F (White)	1	EL2	EL2 solenoid phase	
		2	N	EL2 solenoid neutral	
		3	EG1	EG1 solenoid phase	
		4	N	EG1 solenoid neutral	
P5	INARLOCK 3P 1F (White)	1	EV1	EV1 Phase low flow rate	
		2	N	Common neutral output EV1 and EV2	
		3	EV2	EV2 Phase high flow rate	
P6	INARLOCK 2P 1F (Black)	1	FAN	Cooling fan output - phase	
		2	N	Cooling fan output – neutral	
P7	INARLOCK 2P 1F (White)	1	ABB	Drainage cooling water solenoid phase	
		2	N	Drainage cooling water solenoid neutral	
P8	RJ PLUG 8 contacts 90°	1	-	+13V	Accessory board 1 connection (MODBUS)
		2		GND	
		3		A	
		4		B	
		5		+12V	
		6		GND	
		7		GND	
		8		+13V	
P9	RJ PLUG 8 contacts 90°	1	-	+13V	Accessory board 2 connection (MODBUS)
		2		GND	
		3		A	
		4		B	
		5		+13V	
		6		GND	
		7		GND	
		8		+13V	
P10	RJ PLUG 8 contacts 90°	1	-	+13V	Accessory board 3 connection (MODBUS)
		2		GND	
		3		A	
		4		B	
		5		+13V	
		6		GND	
		7		GND	
		8		+13V	
P11	CPM 4P-5P08	1	CONTROL	+13V	Control board connection (CANBUS)
		2		B	
		3		A	
		4		GND	

P12	MOLEX Microfit 4P	1	-	+13V	Bridge board connection (CANBUS)
		2		B	
		3		A	
		4		GND	
P13	MOLEX Microfit 4P	1	-	+13V	Bridge board connection (CANBUS)
		2		B	
		3		A	
		4		GND	
P28	AMP Modu II 6P	1	-	Potential free contact 1	
		2		GND	
		3		Potential free contact 2	
		4		GND	
		5		Potential free contact 3	
		6		GND	
		2			
P14	CPM-5P-3P81	1	MultiPoint	IN1	Multi point core probe input
		2		IN2	
		3		IN3	
		4		IN4	
		5		GND	
P15	AMP Modu II 2P	1	-	Single point core probe input	
		2			
P16	JST XHP-2	1	CMB2	IN	Top temperature probe
		2		GND	
P17	MINIFIT 2P	1	DOOR1	IN	Door switch 1 input
		2		GND	
P18	MINIFIT 2P	1	DOOR2	IN	Door switch 2 input (only used in trolley ovens)
		2		GND	
P19	JST XHP-2	1	CMB1	IN	Bottom Temperature probe
		2		GND	
P20	AMP Modu II 4P	1	TAC1/2	+13V	Tachometer input TAC1 e TAC2
		2		IN_TAC1	
		3		IN_TAC2	
		4		GND	
P30	AMP Modu II 4P	1	TAC3/4	+13V	Tachometer input TAC3 e TAC4
		2		IN_TAC3	
		3		IN_TAC4	
		4		GND	
P21	MOLEX Minifit 4P	1	21VAC	21V ac	21 V AC power supply from secondary transformer
		2		21V ac	
		3	12VAC	12V ac	12 V AC power supply from secondary transformer
		4		12V ac	
P22	INARLOCK 5P 1F (Black)	1		High-Power contactor phase	
		2	NGAS	TL1 and TL2 neutral	
		3	FGAS	Low-Power contactor phase	
		4	TSA	Safety thermostat output	
		5	TSR	Safety thermostat return	
P24	MOLEX Microfit 6P	1 ÷ 6	-		-

P31	MOLEX Microfit 6P	1	-	+13V	-
		2		SR1	
		3		+13V	
		4		SR2	
		5		+13V	
		6		GND	
P32	JST XHP-2	1	PRES	IN	Pressure switch potential free input
		2		GND	GND
P40	Line connection for Blowers and flame control board	1	-	Phase to the blower	
		2		Neutro to the blowers	
E1	fixing screw	1	E1	Ground connection	

► Fuse list

FUSE	NOMINAL CURRENT	NOMINAL VOLTAGE	SPEED OF INTERVENTION	PROTECTED CIRCUIT
F2	2A	250V	Fast (F)	Primary transformer (TR60 230V-12V 60VA)
F3	2A	250V	Fast (F)	Detergent pump (PD output on P4 socket)
F4	4A	250V	Time delay (T)	Secondary transformer (TR60 230V-12V 60VA)
F7	2A	250V	Fast (F)	Gas control unit BRAHMA ECM113
F9	2A	250V	Fast (F)	Blower gas premix

► Mechanical dimension

DIMENSION X	420 mm
DIMENSION Y	145 mm
MAXIMUM HEIGHT	49 mm
FIXING HOLES DIAMETER	4,06 mm

► Working parameter

PARAMETER	MINIMUM VALUE	MAXIMUM VALUE
WORKING TEMPERATURE	+10 °C	+70 °C
STORAGE TEMPERATURE	-10 °C	+70 °C
WORKING HUMIDITY	-	80%
STORAGE HUMIDITY	-	90%

► Regulations

The PE2022A circuit board has been designed and built in order to fulfill the following legislation:

Reference Guidelines:

low voltage: 73/23/CEE
electromagnetic compatibility: 89/336/CEE

General reference rule:

electromagnetic compatibility - emission: CEI EN50081-1
electromagnetic compatibility - immunity: CEI EN50082-1

GENERAL DESCRIPTION PE2143B

- The [KPE2143B](#) BOARD IS NOT COMPATIBLE WITH THE KPE2143A
- The [KPE2143B](#) has been introduced with the plus Big.1 version oven. The new auxiliary power board allows for the redistribution the loads on the phases to decrease the absorption of the single phases.
- [KPE2143B](#) has different kind of cable harness compare to KPE2143A
- It controls oven loads (contactors, motors, solenoid valves, core probe) in association with PE2038A0, PE2021B0, PE2021C0, PE2022A0.
- It reads values coming from different sensors (such as probe)
- It communicates via CANBUS with the control board

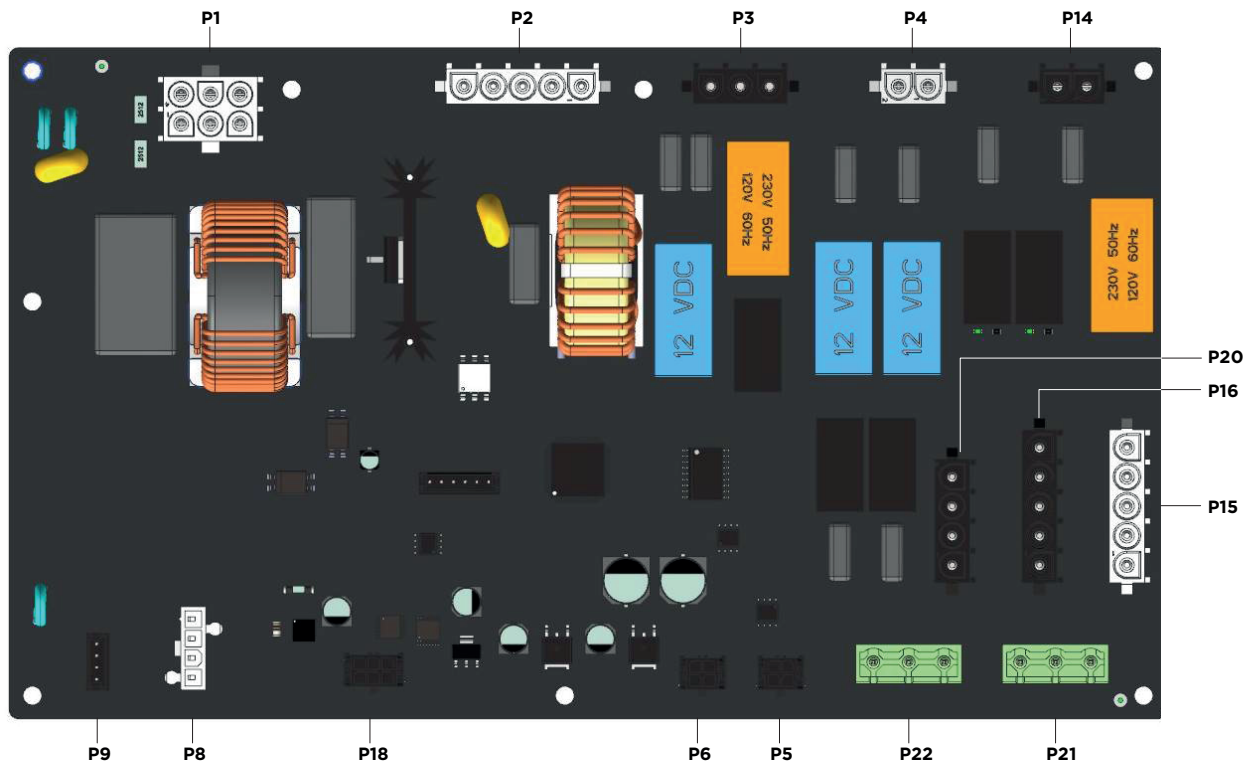

► Output

NAME	LOAD DESCRIPTION	ACTUALIZATION	VOLTAGE	CURRENT (MAX N°LOAD)	TYPE OF LOAD	MAX N° LOAD
TL3	Contactor group #3	Relay (RL8)	230 Vrms		G	4
TL4	Contactor group #4	Relay (RL9)	230 Vrms		G	4
V2V	DRY.Maxy solenoid	Relay (RL2)	230 Vrms		B	2
FAN	Cooling fan output	Relay (RL7)	230 Vrms	2	E	-
RES_1	Breaking element # 1 (group 2)	Relay (RL4)	230 Vrms	-	-	3
RES_2	Breaking element # 2 (group 2)	Relay (RL5)	230 Vrms	-	-	3
MOT_FWRW	Motor revolution direction	Relay (RL1)	-	-	-	3
STBY	Neutral cut off	Relay (RL6)	-	-	-	-
TRIAC	Output motors group #2	Triac (Q1)	230Vrms			3

REF.	DESCRIPTION	ITEM CODE	I	V	F	R @ 100Hz	DCR
A	Contactora	VE1095A0	30 mA	230 V ~	50 Hz	2 kΩ	770 Ω
B	Solenoid valve	VE2377A0	30 mA	230 V ~	50 Hz	4.7 kΩ	4.3 kΩ
E	Cooling fan	VN1165A0	130 mA	230 V ~	50 Hz	1.1 kΩ	626 Ω
F	Motor	MT1012A0	1.62	240V	60 Hz	30.5	
G	Contactora	VE1095A0		230 V ~	50-60 Hz		

LEGEND	
I	Absorbed current from load
V	Load voltage
F	Line frequency
R @ 100Hz	Measured value resistance @ 100Hz
DCR	DC resistance measured value

► Input

NAME	INPUT DESCRIPTION	INPUT TYPE	RANGE	RESOLUTION	PRECISION	PHYSICAL INPUT
BRD_TEMP	Board temperature probe	Analogue NTC	0 – 100°C (32-212°F)	1°C between -20 °C and +80°C (-4F to 176F)	+/- 5 °C	
HEART_1	Single point core probe or probe #1 of multipoint core probe	Analogue PT1000	0 – 300°C (32-572°F)	0.1°C	+/- 0.5 °C	✓
HEART_2	Probe #2 of multipoint core probe	Analogue PT1000	0 – 300°C (32-572°F)	0.1°C	+/- 0.5 °C	✓
HEART_3	Probe # 3 of multipoint core probe	Analogue PT1000	0 – 300°C (32-572°F)	0.1°C	+/- 0.5 °C	✓
HEART_4	Probe # 4 of multipoint core probe	Analogue PT1000	0 – 300°C (32-572°F)	0.1°C	+/- 0.5 °C	✓
TAC_1	Tachometer group 1 (speed)	Analogue	30 – 10K RPM	1 RPM	+/- 1 RPM	✓
TAC_2	Tachometer group 2 (direction)	Analogue	30 – 10K RPM	1 RPM	+/- 1 RPM	✓
IAC_MOT	Motors AC current absorbed	Analogue	0 - 8 A _{RMS}	1 mA _{RMS}	+/- 50 mA _{RMS}	
VDC	Direct voltage on bus	Analogue	0 – 15 V	1 mV	+/- 20mV	
IDC	Direct current	Analogue	0 – 7 A	1 mA	+/- 5mA	
AC_FREQ	Frequency of voltage line	Analogue	0 - 50 - 60 Hz	-	-	
MOTDIR	Sense of rotation (from TAC1-TAC2)	Digital	-	-	-	
CP_1	Digital input voltage free contact # 1	Digital	-	-	-	✓
CP_2	Digital input voltage free contact # 2	Digital	-	-	-	✓
ALL_TM	Thermal protection alarm	Digital	-	-	-	
ALL_VAC	Line voltage presence	Digital	-	-	-	

► Communication ports

There are 2 CANBUS ports for communication with the control board and the DC section input (P5, P6)

► Feed Line

PARAMETER	NOMINAL VALUE	MINIMUM VALUE	MAXIMUM VALUE
LINE VOLTAGE	230 V _{AC}	180 V _{AC}	270 V _{AC}
LINE FREQUENCY	-	50 Hz	60 Hz

► List of connectors

CONNECTOR NUME	CONNECTOR TYPE	PIN NUMBER	MAXIMUM VALUE	DESCRIPTION
P1	INARLOCK 6P 2F (White)	1	N	Auxiliary Board feed (neutral)
		2	-	Not used
		3	-	Not used
		4	L	Auxiliary Board feed (phase)
		5	COND	Capacitors
		6	COND	Capacitors
P2	INARLOCK 5P 1F (White)	1	N	Neutral motor group # 2
		2	RW	Output counterclockwise rotation group motor #2
		3	FW	Output clockwise rotation group motor #2
		4	F	230 Vac Phase motor group # 2
		5	TM	Motor thermal protection group # 2
P3	INARLOCK 3P 1F (Black)	1	RES1	Motor Braking element #1 -GROUP # 2
		2		
		2	RES2	Motor Braking element #2 -GROUP # 2
		3		
P4	INARLOCK 2P 1F (White)	1	V2V	Valve output ON-OFF
		2	N	Valve neutral
P14	INARLOCK 2P 1F (Black)	1	FAN	Auxiliary cooling fan output
		2	N	Neutral cooling fan
P15	INARLOCK 5P 1F (White)	1	TL1	TL1 input from PE2038
		2	-	Not used
		3	TL2	TL2 Input from PE2038
		4	TSA	Safety thermostat input from PE2038
		5	TSR	Safety thermostat input to PE2038
P16	INARLOCK 5P 1F (Black)	1	TL1	Phase output contactor # 1
		2	N	Contacteur neutral output
		3	TL2	Phase output contactor # 2
		4	TSA	Safety thermostat output
		5	TSR	Safety thermostat return

P20	INARLOCK 4P 1F (Black)	1	TL3	Output phase # 3	
		2	N	Neutral output contactor # 3	
		3	N	Neutral output contactor # 4	
		4	TL4	Output phase # 4	
P5, P6	MOLEX Microfit 4P	1	-	+13V	Bridge connection (CANBUS)
		2		B	
		3		A	
		4		GND	
P18	Molex Microfit 6P 2F	1	Multi- point	HEART_4	Multipoint core probe input
		2		-	
		3		GND	
		4		HEART_1	
		5		HEART_2	
		6		HEART_3	
P8	MINIFIT 4P	1	DI1	IN	Auxiliary input #1
		2		GND	
		3	DI2	IN	Auxiliary input #2
		4		GND	
P9	AMP Modu II 4P	1	TAC1/2	+13V	Tachometer input TAC1 and TAC2
		2		IN_TAC1	
		3		IN_TAC2	
		4		GND	
P12	INARLOCK 5P 1F (Black)	1	N	Motors' Neutral input from PE2038	
		2	RW	Input RW (reverse) motors from PE2038	
		3	FW	Input FW (forward) motors from PE2038	
		4	F	Motors' input phase from PE2038	
		5	TM	Output thermal protection towards PE2038	
P11	INARLOCK 5P 1F (White)	1	N	Motors' Neutral output group # 1	
		2	RW	Output RW (reverse) motors' group # 1	
		3	FW	Output FW (forward) motors' group # 1	
		4	F	Output TSA motors' group # 1	
		5	TM	Input TSR motors' group # 1	

► Environmental parameters

PARAMETER	MINIMUM VALUE	MAXIMUM VALUE
WORKING TEMPERATURE	+10 °C (50F)	+70 °C (158F)
STORAGE TEMPERATURE	-10 °C (14F)	+70 °C (158F)
ENVIRONMENTAL WORKING HUMIDITY	-	80%
STORAGE HUMIDITY	-	90%

GENERAL DESCRIPTION PE2102A

PE2102A0 is the board that is used for the following purposes:

- manage the oven load (contactors, motors, solenoid valve, etc.);
- read the measurements taken by the different sensors (temperature probes, door switch, etc.)
- powering the low voltage of the entire system;
- communicate via CANBUS with the control board and possible bridge boards.

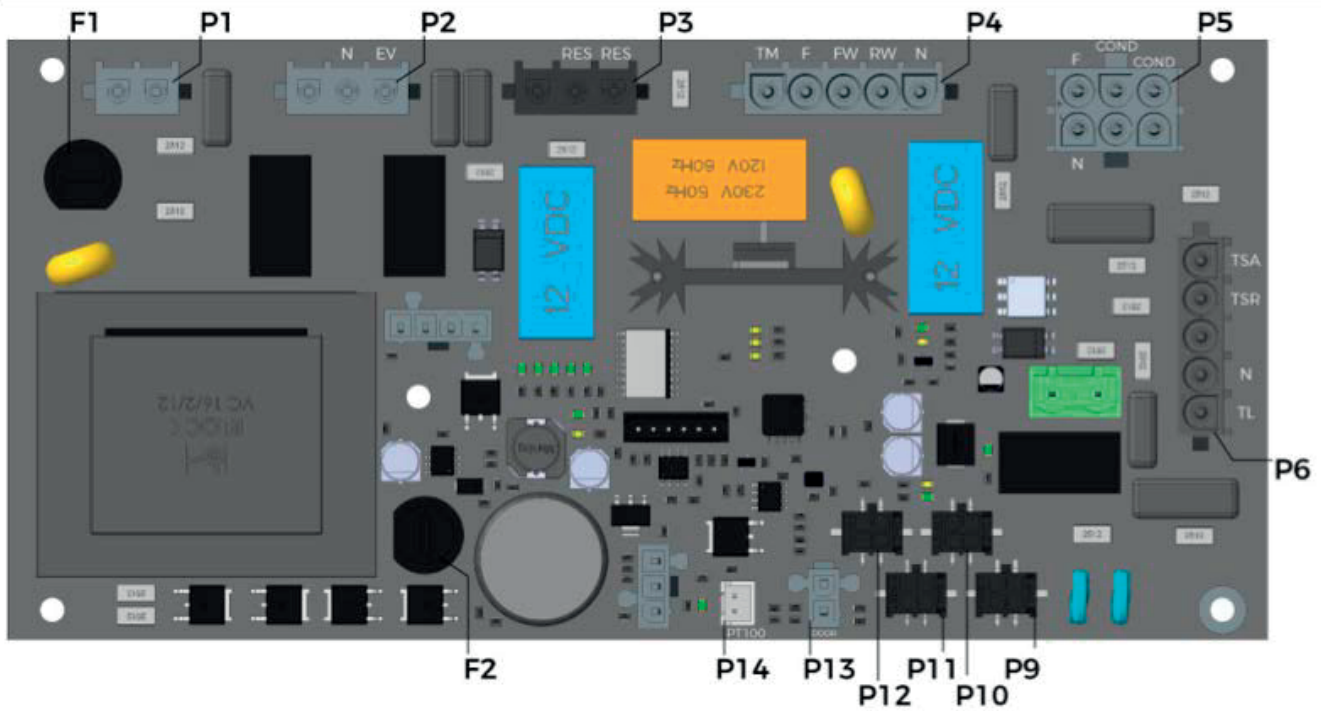

The characteristics of PE2102A0 are reported in **Table 2**.

Power board	Transformer size	Steam valve or steam pump socket	Braking element socket	Number of CANBUS sockets
PE2102A0	16 VA	✓	✓	4

Table 5
PE2121A0

► Transformer connection

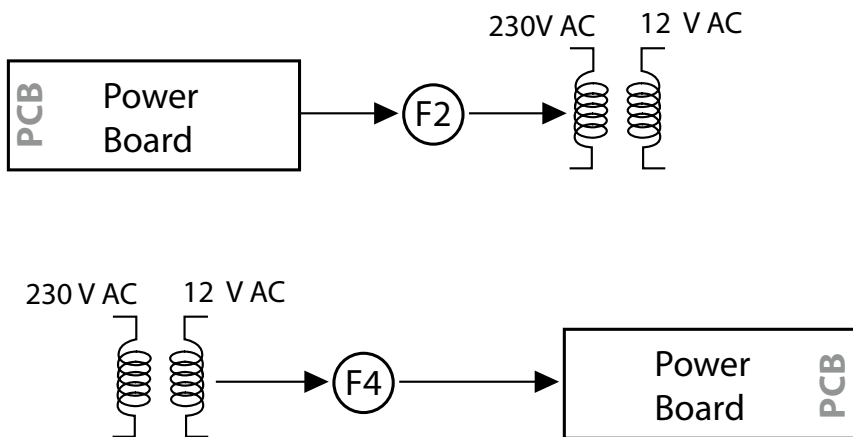

The transformer is electronic and included in the power board. The primary turn of the transformer is powered at 230 VAC. The secondary turn of the transformer translates the 230 VAC into 12 VAC. F1 fuse (size: 160 mA – 250 V, type: Fast Acting) is between the power board and the transformer primary turn.

When the transformer is shorted, F1 blows to protect the circuits of the power board. The power board receives the low voltage from the secondary turn of the transformer. F2 fuse (size: 2 A – 250 V, type: Time Delayed) is between the transformer

secondary turn and the power board. When one or more low voltage components are shorted, F2 blows to protect the secondary turn of the transformer, see Fig. 14.

► Output

NAME	LOAD DESCRIPTION	ACTUALIZATION	VOLTAGE	CURRENT (MAX N°LOAD)	TYPE OF LOAD	MAX N° LOAD
TL	Contactors	RL4	240 Vrms	120 mA	A	.
EV	Steam solenoid valve	RL3	240 Vrms	60 mA	B	.
FAN	Cooling fan	RL2	240 Vrms	260 mA	E	.
RES	Braking element number 1	RL7	240 Vrms	-	-	.
MOT2	Motor direction	RL6	240Vrms	8A	F	.
MOT1	Motor triac control (ON/OFF)	Triac	240 Vrms	8 A	F	.
BUZZ	Motor triac control (ON/OFF)	Mosfet	12Vcc		G	.
LATCH	Motor triac control (ON/OFF)	Mosfet	12Vcc		-	.

REF.	DESCRIPTION	I	V	F	P	Q	S	PF	L @ 100Hz	R @ 100Hz	Z @ 100Hz	DCR	X/R	θ
A	Contactors	30 mA	230 V	50 Hz	2 W	6 Var	6.5 Va	0.31	13 H	2 kΩ	9.4 kΩ	770 Ω	4.42	77.2°
B	Steam valve	30 mA	230 V	50 Hz	4.7 W	4.5 Var	6.5 Va	0.72	9 H	4.7 kΩ	7.4 kΩ	4.3 kΩ	1.19	50°
E	Cooling fan		230 V	50 Hz	21 W	19 Var	28 Va	0.75	3.4 H	1.1 kΩ	1.6 kΩ	626 Ω	1.11	48.1°
F	Motor	1.62 A	240V	60 Hz	388W	-	-			30.5				
G	External buzzer 12V	10 mA	12Vcc	cc	50 Hz									

LEGEND

I	Load current consumption
V	Voltage applied to the load
F	Frequency
P	Load active power
Q	Load reactive power
S	Load apparent power
PF	Power Factor (PF=P/S)
L @ 100Hz	@ 100Hz measured inductance
R @ 100Hz	@ 100Hz measured resistance
R @ 100Hz	@ 100Hz measured impedance
DCR	Measured resistance in DC
X/R	$Q= X/R $ (X=reactance, R=resistance)
θ	Angle between real axis and the impedance vector

► input

NAME	INPUT DESCRIPTION	TYPE OF INPUT	RANGE	SENSITIVITY	ERROR	HARDWARE INPUT
CMBI	Temperature probe	Analogue PT100	0 – 300 °C	1°C	+/- 1 °C	
BOARD	Board temperature probe	Analogue NTC	0 – 100 °C	5°C	+/- 5 °C	✓
VDC	Direct voltage	Analogue	0 - 18Vdc	0,01 V	+/- V	✓
IDC	Direct current	Analogue	0 – 5 A	1 mA	+/- mA	✓
AC_FREQ	Frequency of the network voltage	Analogue	0 - 50 - 60 Hz	-	-	✓
DOOR	Door switch	Digital	-	-	-	✓
ALL_TS	Safety thermostat	Digital	-	-	-	✓
SYNC	Network sync and motor thermal protection	Digital	-	-	-	
VAC	Power supply alternate voltage	Analogue	0 – 270 Vac	-	-	

► Communication socket

Power board comes with:

- 1 canbus socket to communicate with the control board (p09);
- 3 canbus sockets to communicate with the accessory boards (p10, p11, p12).

► Power supply

PARAMETER	NOMINAL CURRENT	MINIMUM VALUE	MAXIMUM VALUE
VOLTAGE POWER SUPPLY	230 VAC	180 VAC	280 VAC
NETWORK FREQUENCY	-	50 Hz	60 Hz

► Socket table

N° OF SOCKET	SOCKET TYPE	N° PIN	LABEL	DESCRIPTION
P5	INARLOCK 6P 2F (White)	1	N	Board power supply (neutral)
		2		
		3		
		4	L	Board power supply (phase)
		5	FW	Capacitor for the motor startup
		6	RW	Capacitor for the motor startup
P4	INARLOCK 5P 1F (White)	1	N_M	Motor neutral
		2	RW	Motor power supply -counter clock wise spinning
		3	FW	Motor power supply -clock wise spinning
		4	L_F	Phase 230 Vac
		5	TM	Motor thermal protection input

N° OF SOCKET	SOCKET TYPE	N° PIN	LABEL	DESCRIPTION	
P6	INARLOCK 5P 1F (Black)	1	TL1	Contactor output	
		2	N_F	TL1 neutral	
		3			
		4	TSA	Safety thermostat outward	
		5	TSR	Safety thermostat comeback	
P3	INARLOCK 3P 1F (Black)	1	RES1	Braking element	
		2	N_F	Motor neutral	
		3			
P2	INARLOCK 3P 1F (White)	1	EVI	Output steam solenoid valve	
		2	N_F	EVI and VENT neutral	
		3			
P1	INARLOCK 2P 1F (Black)	1	FAN	Cooling fan output - phase	
		2	N_F	Cooling fan output - phase	
P7	CPM 2P 1F (Green)	1	TL1	Contactor output	
		2	N	TL1 neutral	
P9	MOLEX Microfit 4P	1	CANBUS1	L	Accessory board 1 connection (CANBUS)
		2		12Vcc	
		3		GND	
		4		H	
P10	MOLEX Microfit 4P	1	CANBUS2	L	Accessory board 2 connection (CANBUS)
		2		12Vcc	
		3		GND	
		4		H	
P11	MOLEX Microfit 4P	1	CANBUS3	L	Accessory board 3 connection (CANBUS)
		2		12Vcc	
		3		GND	
		4		H	
P12	MOLEX Mi- crofit 4P	1	CANBUS4	L	Accessory board 4 connection (CANBUS)
		2		12Vcc	
		3		GND	
		4		H	
P14	JST XHP-2	1	CMB1 (PT100)	IN	Cooking chamber temperature probe
		2		GND	
P13	MOLEX Minifit 2P	1	DOOR	IN	Door switch 1
		2		GND	
P15	MOLEX Minifit 3P	1	BUZZ	Command 12V	Buzzer output
		2			
		3		GND	

► Fuse list

FUSE	NOMINAL CURRENT	NOMINAL VOLTAGE	activation SPEED	PROTECTED CIRCUIT
F1	160 mA	250V	Fast (F)	Primary of the transformer
F2	2 A	250V	Time delay (T)	Secondary of the transformer

► Mechanical dimension

DIMENSION X	210 mm
DIMENSION Y	100 mm
MAXIMUM HEIGHT	45 mm
FIXING HOLES DIAMETER	4,06 mm

Software update

Old control panel.....	46
New control panel.....	47

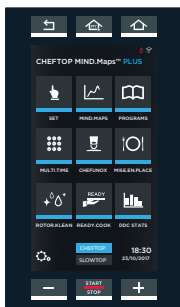

SOFTWARE UPDATE PROCEDURE

OLD PANEL

USB stick configuration

- To upgrade the control, power and internet connection boards proceed as follows:
 - enter the Unox DDC service web-page (<https://ddc-service.unox.com>) and select the model you want to update the software and download the software.
 - download the software by clicking the link corresponding to the oven version, PLUS or ONE;
 - save the file in a folder on your PC desktop;
 - use the UNOX oven USB stick to upgrade the software.

If you do not have the UNOX oven USB stick, you can use any USB with:

- capacity within the range 4-16 GB;
- formatting with FAT32.

1A

PRODUCT CODE
XEVL-2011-YPRS

CHEFTOP MIND.Maps™ PLUS BIG
XEVL-2011-YPRS

Capacity:	Frequency:	Voltage / Cable section:	Tray distance:
20 GN1/1	50 / 60 Hz	380V 3N~	67 mm
Power:	Weight:	Dimensions (WxDxH):	
38.5 kW	292 kg	892x1018x1875	

[3D SPARE PARTS](#)
[SPARE PARTS CATALOG PDF](#)

DOCUMENTS

<p>TECHNICAL DATA</p> <p>Download ↓</p>	<p>USER MANUAL</p> <p>Download (IT) ↓</p>	<p>SERVICE MANUAL</p> <p>Download (EN) ↓</p>
<p>SUGGESTED SPARE PARTS</p> <p>Download ↓</p>	<p>DWG SIZES 2D</p> <p>Download ↓</p>	<p>DWG SIZES 3D</p> <p>Download ↓</p>

FIRMWARE

<p>PE1062 - 43440 (16/07/2020)</p> <p>Download ↓</p>	<p>PE2045 - 43430 (16/07/2020)</p> <p>Download ↓</p>
--	--

1B

- 2 Insert the USB stick into your PC.
- 3 Unzip the folder just saved on your desktop.
- 4 Open the USB stick, copy the UNOXDIR folder from the unzipped file and paste it in the USB.

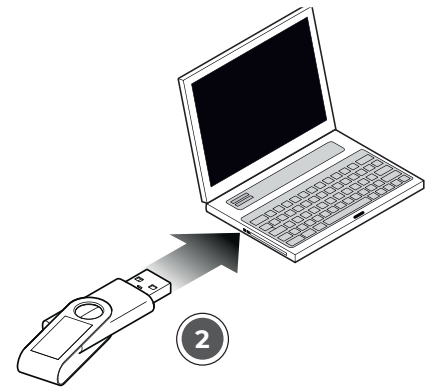
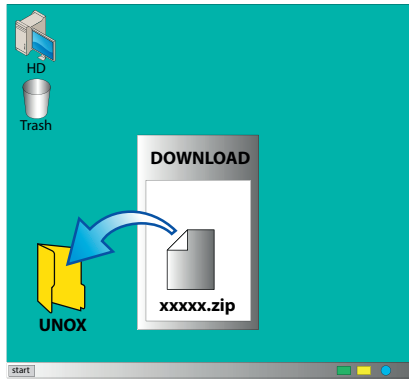

Forced upgrade procedure

If the regular upgrade procedure does not work or when you have to replace the control panel and recover the original SD card, proceed as follows:

- 1 Make sure you have the latest software available saved in the folder "FIRMWARE" of your USB stick.
- 2 Rename the software from 2036.bin, 2035.bin or 2045.bin to:
2036_F.bin for PLUS ovens
2035_F.bin for ONE ovens
2045_F.bin for PLUS BIG ovens

If you are replacing the control board follow steps "3" and "4" otherwise skip to step "5".

- 3 Remove the SD card from OLD panel.
- 4 Insert this SD card inside the NEW control panel.
- 5 PLUG the USB stick with the renamed file and then SWITCH ON the oven by pressing the power button.
- 6 Turn on the oven and wait until the forced upgrade is complete.
- 7 Upgrade the parameters of the model with the standard procedure above starting at section "Load the parameter file procedure" on page 49.
- 8 After the forced upgrade the oven will automatically change the name of the software file to 2036_.bin or 2035_.bin or 2045_.bin.

Therefore rename the file if you intend to use the file in regular procedure:
2036_.bin -> to 2036.bin (PLUS)
2035_.bin -> to 2035.bin (ONE)
2045_.bin -> to 2045.bin (PLUS BIG)

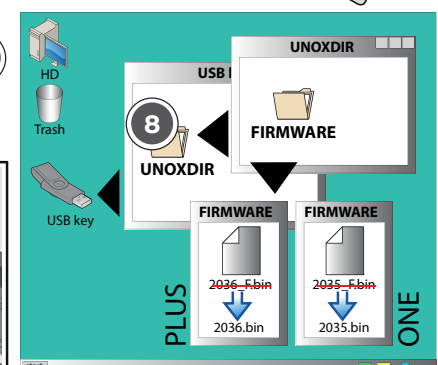
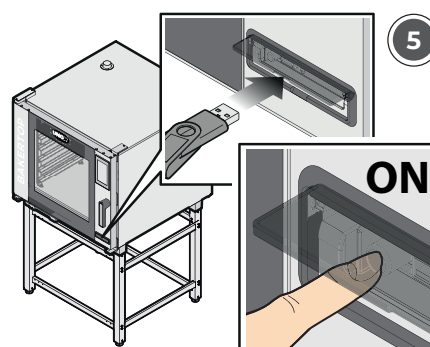
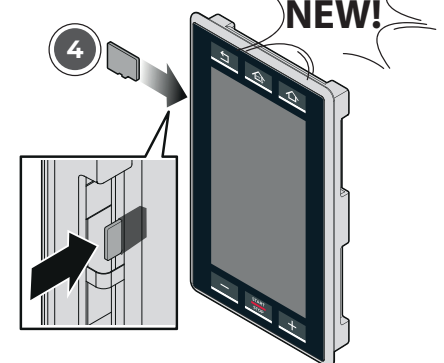
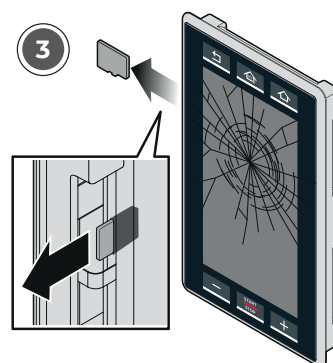
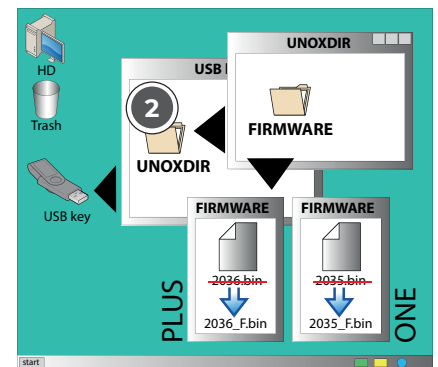
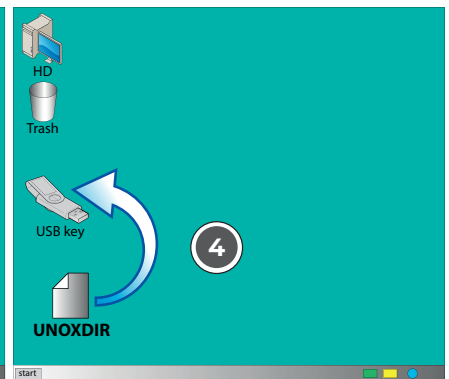
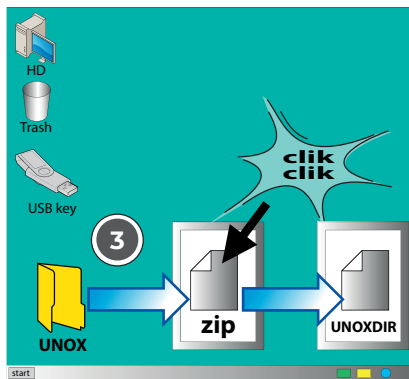

Regular software upgrade procedure

- 1 Turn the oven on.
- 2 Press "UTILITIES" function.
- 3 Connect the USB drive to the USB port.
- 4 Press "SETTINGS" function (gear icon).
- 5 Enter the service menu (pin: 99857).
- 6 Press "UPDATE FIRMWARE" function.
- 7 Select the board that you want to upgrade. A status bar will appear on the display. Once the upgrading procedure is accomplished, unplug the USB stick and reboot the oven manually by pressing the power button.

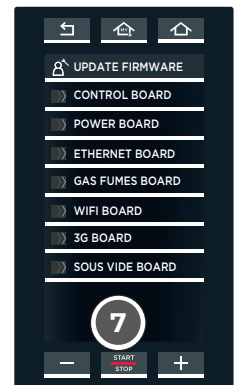
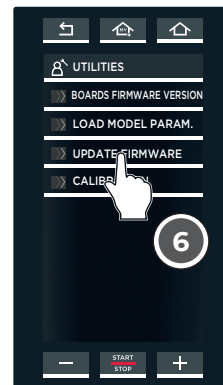
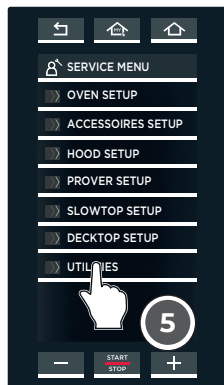
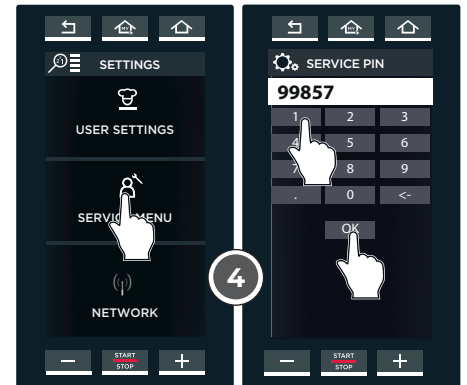
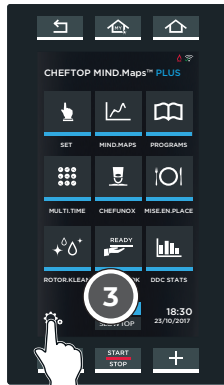
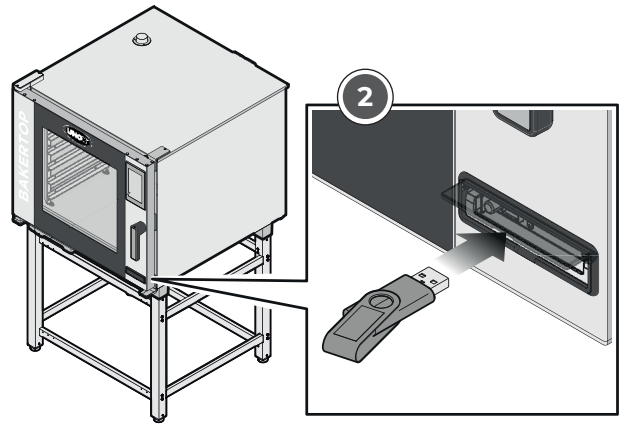
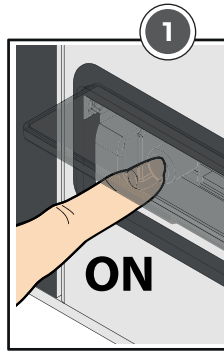

Load the parameter file procedure

- 1 Connect the USB stick to the USB port.
- 2 Press the "SETTINGS" function (gear icon).
- 3 Enter the user menu (pin: 99857)
- 4 Press "UTILITIES" function.
- 5 Press "LOAD MODEL PARAM". Function to load model parameters and enter the model of the oven (i.e. XEVC-0511-EPR).
- 6 Press "OK" to save the model parameters.

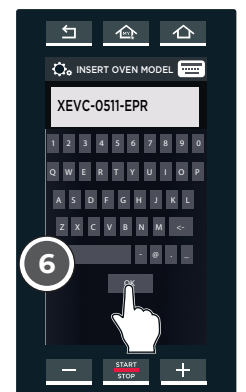
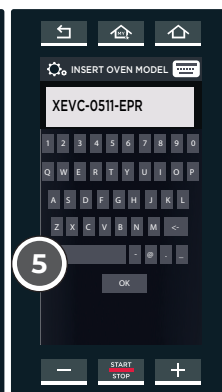
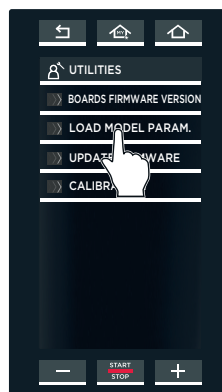
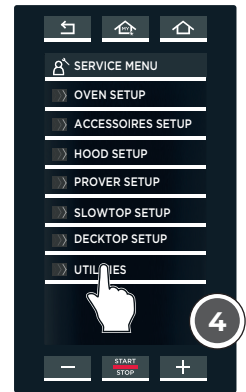
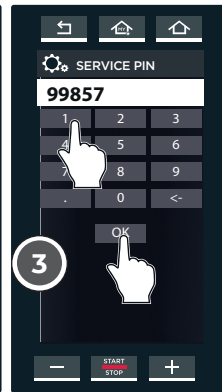
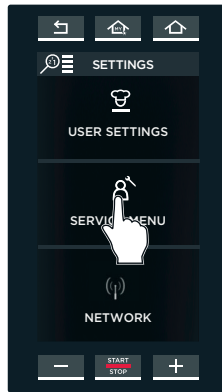
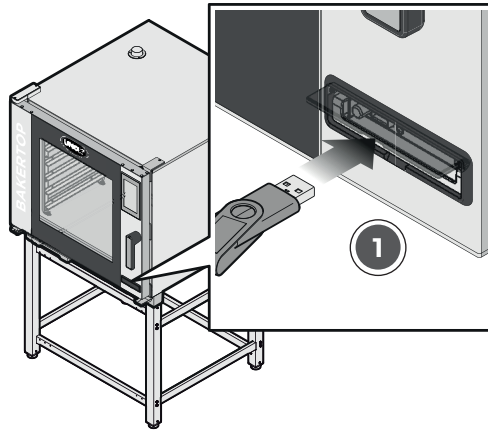

UPDATE PROCEDURE WITHOUT HYPER SMOKER

In case of software upgrading of an oven without SMOKER system follow the steps below.

How to distinguish an oven with the SMOKER system from a normal oven?

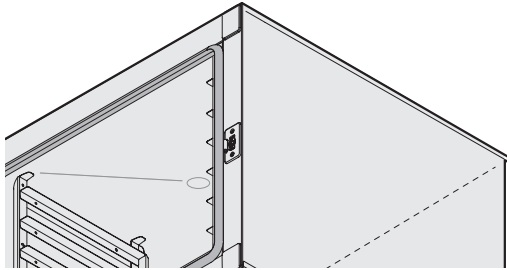

NORMAL OVEN

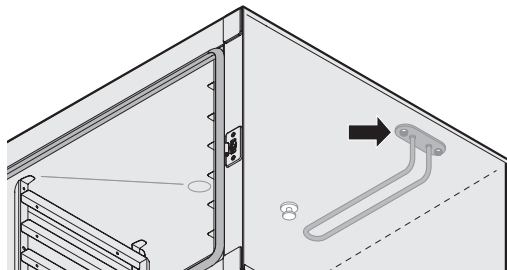

SMOKER SYSTEM

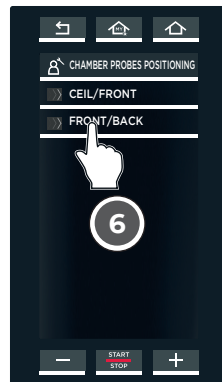
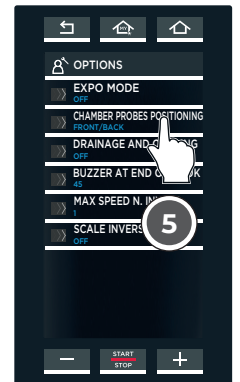
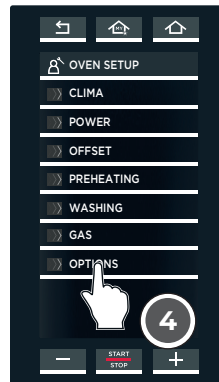
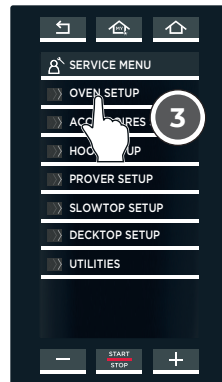
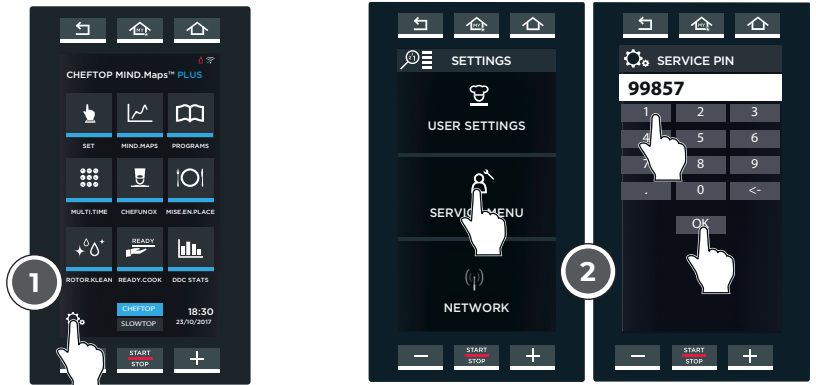

- 1 Press the "SETTINGS" function (gear icon).
- 2 Enter the user menu (pin: 99857)
- 3 Press "OVEN SETUP" function.
- 4 Press "OPTIONS" function.
- 5 Press "CHAMBER PROBES POSITIONING" function.
- 6 Set the parameter above to "FRONT/BACK".

If during the software upgrading the oven shows you the message “USB not found”, proceed as follows:

- 1 Format the USB stick using FAT32 system file;
- 2 If the USB stick is already FAT32 formatted, verify the CONTROL/USB board connection cable according to the following the **Figure 1**.



WRONG cable code is CE1052A0/CE1054A0 on the basis of the model you have.

CORRECT cable code is CE1052A1/CE1090A0 on the basis of the model you have.

If during the software upgrading the oven shows you the message FILE not found, proceed as follows:

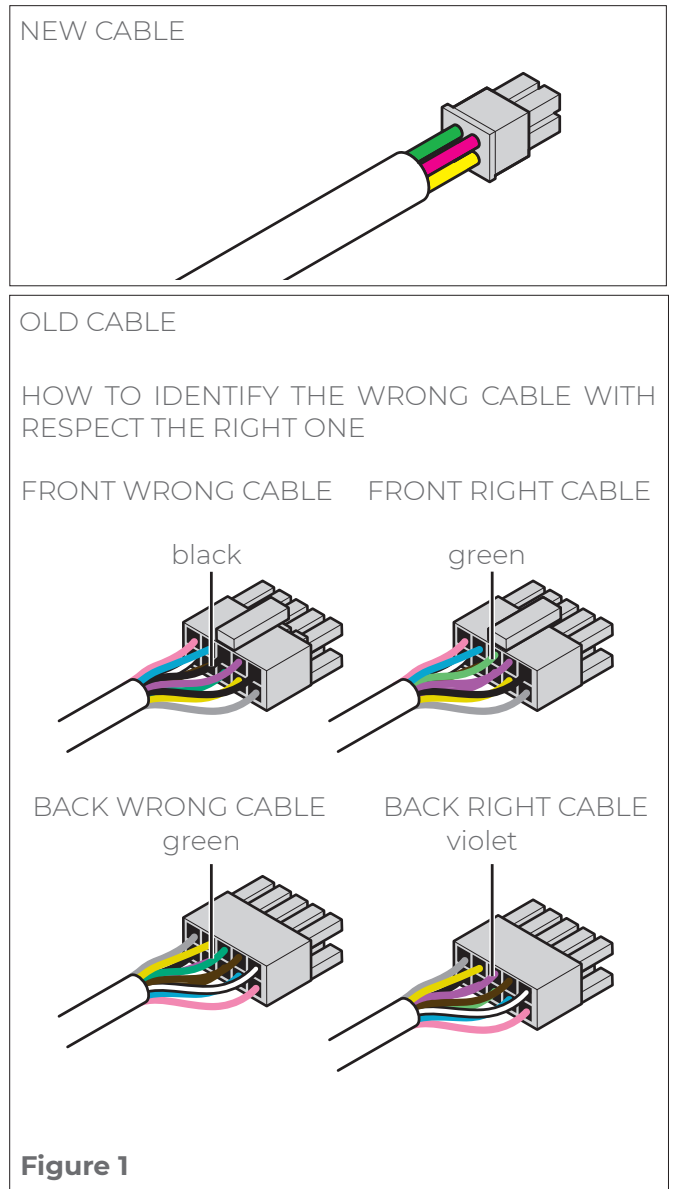
- Verify that inside the USB stick there is the UNOX-DIR folder with inside at least the Software and PARAM folders;
- Verify the proper name of the file type and name according to the electronic board that you are going to upgrade. Refer to the table below.



ELECTRONIC BOARD	FW NAME
PE2038A0 PLUS electrical ovens power board	2038.bin
PE2037A0 ONE electrical ovens power board	2037.bin
PE2021A0 PLUS EU gas ovens power board	2021.bin
PE2022A0 PLUS USA gas ovens power board	2022.bin
PE2052A0 ethernet board	2052.bin
PE2053A0 Wi-Fi board	2053.bin
 PE2054A0 EU 3G board	2054.bin
 PE2064A0 3G Asia – Australia board	2064.bin
integrate WiFi board	1057_W.bin
PE2036A0 PLUS RESISTIVE control board	2036.bin
PE2035A0 ONE RESISTIVE control board	2035.bin
PE2045A0 BIG PLUS RESISTIVE control board	2045.bin

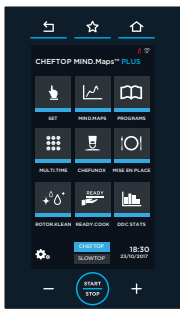

SOFTWARE UPDATE PROCEDURE

NEW PANEL

USB stick configuration

- 1 To upgrade the control, power and internet connection boards proceed as follows:
 - enter the Unox DDC service web-page (<https://ddc-service.unox.com>) and select the model you want to update the software and download the software.
 - download the software by clicking the link corresponding to the oven version, PLUS or ONE;
 - save the file in a folder on your PC desktop;
 - use the UNOX oven USB stick to upgrade the software.

If you do not have the UNOX oven USB stick, you can use any USB with:

- capacity within the range 4-16 GB;
- formatting with FAT32.

- 2 Insert the USB stick into your PC

1A

PRODUCT CODE
XEVL-2011-YPRS

CHEFTOP MIND.Maps™ PLUS BIG
XEVL-2011-YPRS

Capacity:	Frequency:	Voltage / Cable section:	Tray distance:
20 GN/1	50 / 60 Hz	380V 3N~	67 mm
Power:	Weight:	Dimensions (WxDxH) :	
38.5 kW	292 kg	892x1018x1875	

3D SPARE PARTS
SPARE PARTS CATALOG PDF

DOCUMENTS

TECHNICAL DATA Download	USER MANUAL Download (IT)	SERVICE MANUAL Download (EN)
SUGGESTED SPARE PARTS Download	DWC SIZES 2D Download	DWC SIZES 3D Download

FIRMWARE

PE1062 - 43440 (16/07/2020) Download	PE2045 - 43430 (16/07/2020) Download
--	--

1B

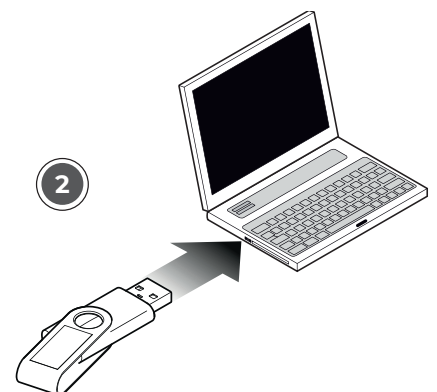
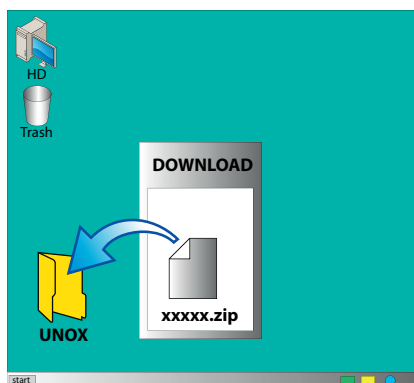

- 3 Unzip the folder just saved on your desktop.
- 4 Open the USB stick, copy the UNOXDIR folder from the unzipped file and paste it in the USB.

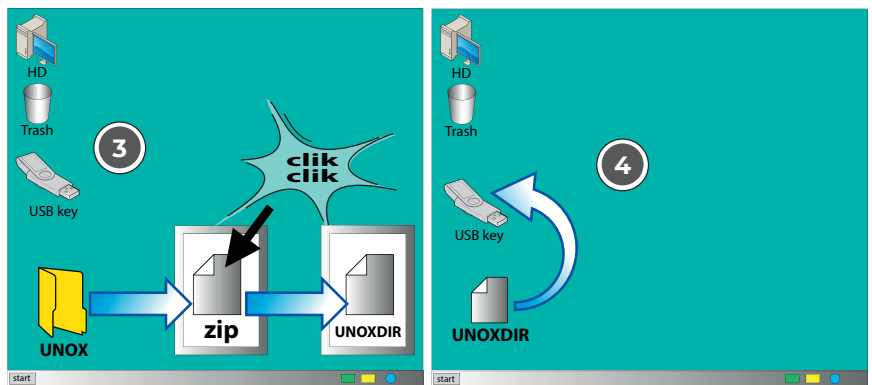

Forced upgrade procedure

If the regular upgrade procedure does not work and when you have to replace the control panel and recover the original SD card, proceed as follows:

- 1 Make sure you have the latest software available saved in the folder "FIRMWARE" of your USB stick.
- 2 Rename the software:
 from 1057.bin -> to 1057_F.bin (KPE1057)
 from 1058.bin -> to 1058_F.bin (KPE1058)
 from 1062.bin -> to 1062_F.bin (KPE1062)

If you are replacing the control board follow steps "3" and "4" otherwise skip to step "5".

- 3 Remove the SD card from OLD panel.
- 4 Insert this SD card inside the NEW control panel.
- 5 PLUG the USB stick with the renamed file and then SWITCH ON the oven by pressing the power button.
- 6 Turn on the oven and wait until the forced upgrade is complete.
- 7 Upgrade the parameters of the model with the standard procedure above starting at section "Load the parameter file procedure".
- 8 After the forced upgrade the oven will automatically change the name of the software file to 1057_.bin, 1058_.bin or 1062_.bin.

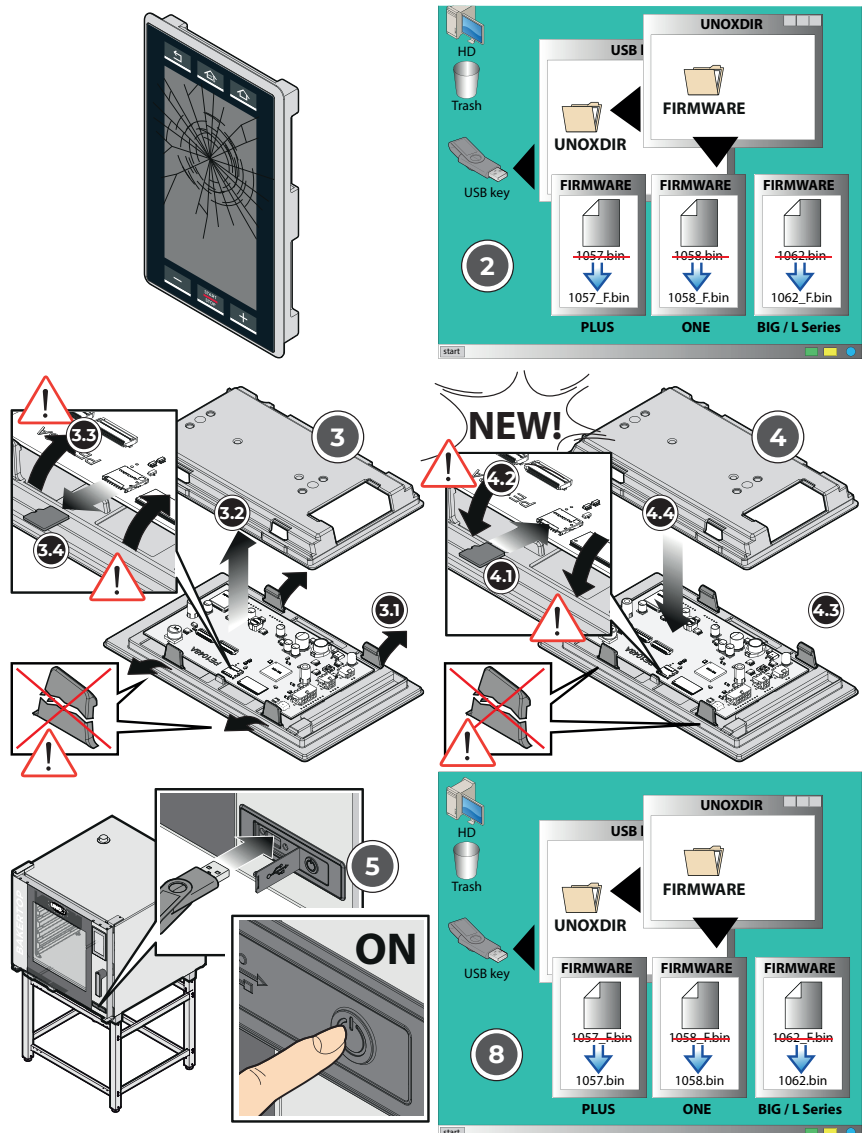

Therefore rename the file if you intend to use the file in regular procedure:
 from 1057_.bin -> to 1057.bin (KPE1057A)
 from 1058_.bin -> to 1058.bin (KPE1058A)
 from 1062_.bin -> to 1062.bin (KPE1062A)

Regular software upgrade procedure

- 1 Turn on the oven.
- 2 Connect the USB drive to the USB port.
- 3 Press "SETTINGS" function (gear icon).
- 4 Enter the service menu (pin: 99857).
- 5 Press "UTILITIES" function.
- 6 Press "Update firmware" function.
- 7 Select the board that you want to upgrade. A status bar will appear on the display. Once the upgrading procedure is accomplished, unplug the USB stick and reboot the oven manually by pressing the power button.

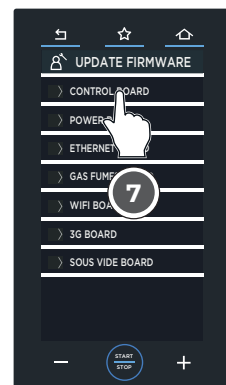
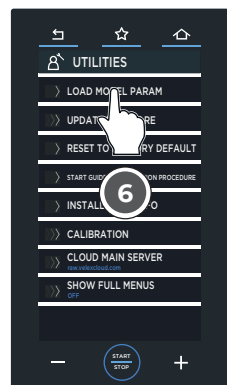
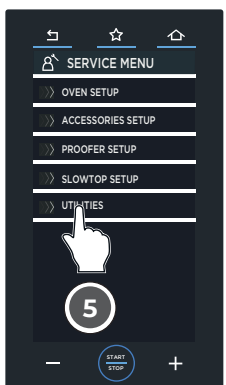
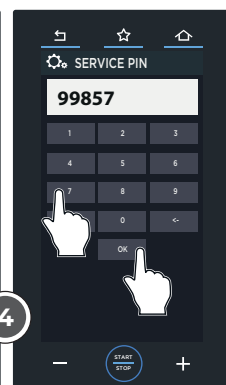
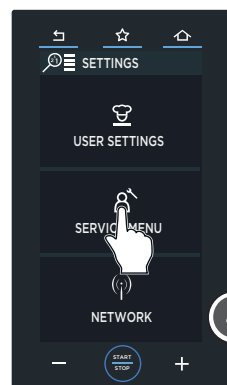
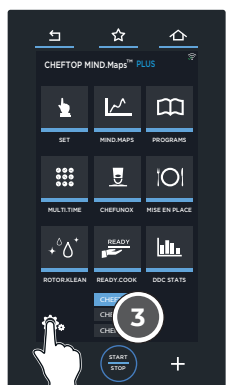
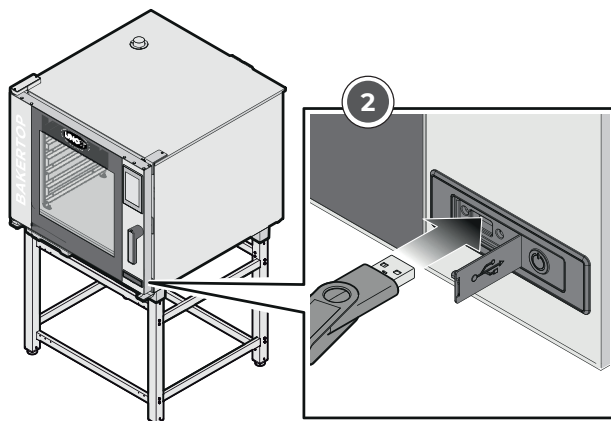
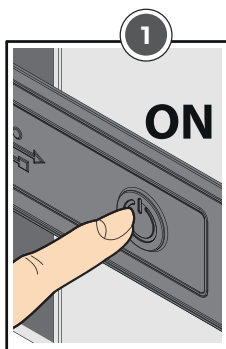

Load the parameter file procedure

- 1 Connect the USB stick to the USB port.
- 2 Press the "SETTINGS" function (gear icon).
- 3 Enter the service menu (pin: 99857).
- 4 Press "UTILITIES" function.
- 5 Press "LOAD MODEL PARAM". Function to load model parameters and enter the model of the oven (i.e. XEVC-0511-EPRM.0).
- 6 Press "OK" to save the model parameters.

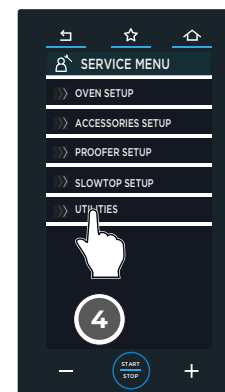
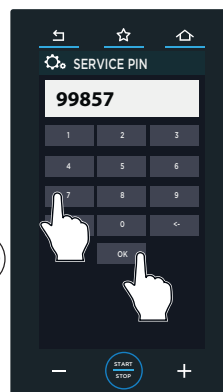
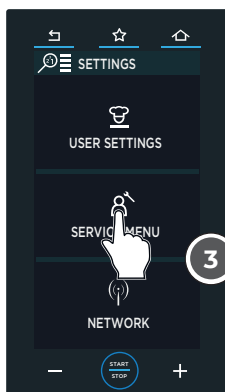
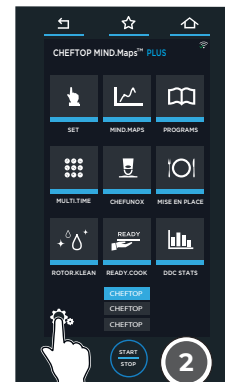
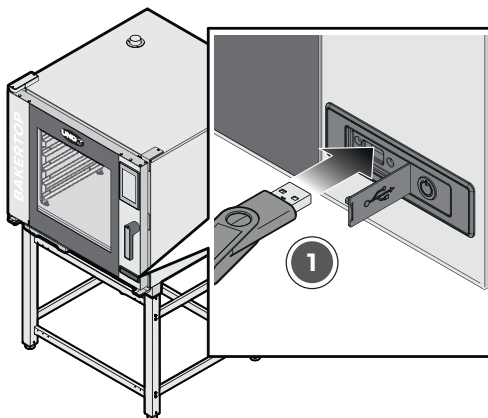

7 Go back to the service menu (using the back arrow in PLUS ovens and the “gear” icon in ONE ovens).

8 Press “OVEN SETUP”.

9 Press “WASHING”.

10 Press the “WASHING VALVES TYPE” parameter and select NORMAL or SELF-CLEANING according to the type of washing valves of the oven.

11 (Only for PLUS ovens) Press the NUMBER OF ROTORS parameter and set it to “1”, “2” or “3” according to the number of rotor arms of the oven).

12 Save the settings by pressing one of the home icons on top (the one in the middle) for PLUS ovens or the book icon for ONE ovens.

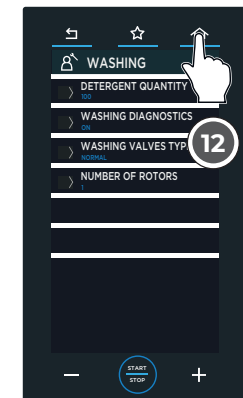
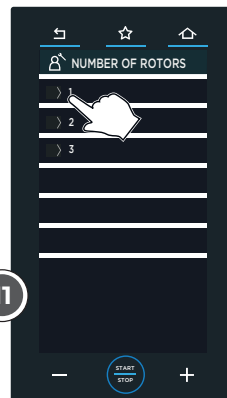
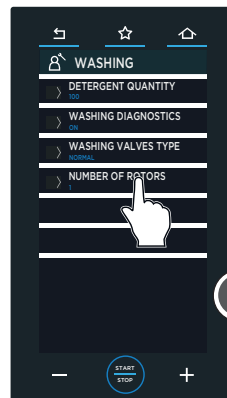
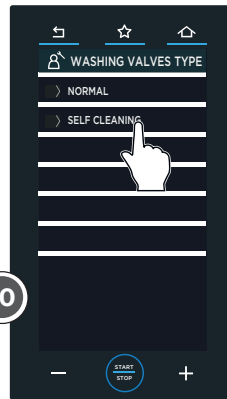
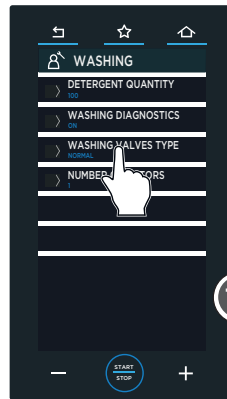
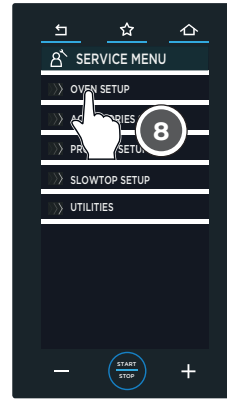

UPDATE PROCEDURE WITHOUT HYPER SMOKER

In case of software upgrading of an oven without SMOKER system follow the steps below.

How to distinguish an oven with the SMOKER system from a normal oven?

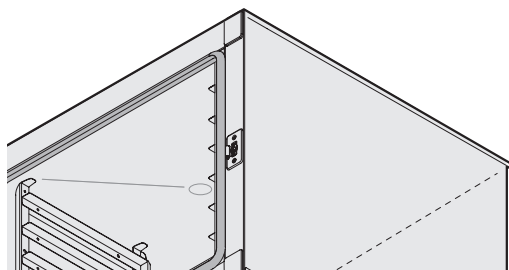

NORMAL OVEN

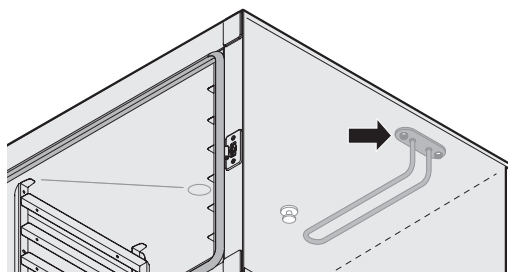

SMOKER SYSTEM

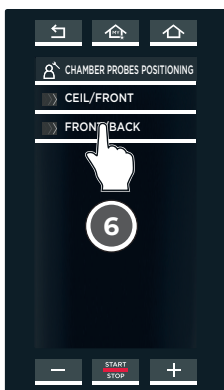
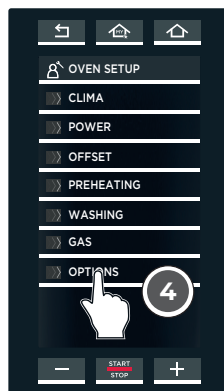
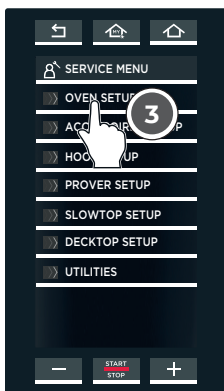
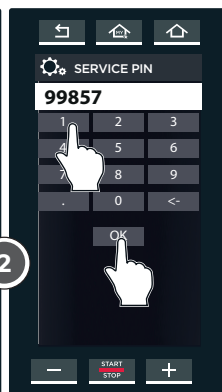
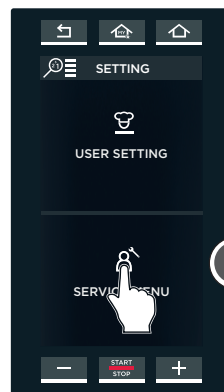
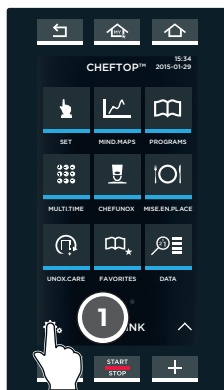

- 1 Press the "SETTINGS" function (gear icon).
- 2 Enter the user menu (pin: 99857)
- 3 Press "OVEN SETUP" function.
- 4 Press "OPTIONS" function.
- 5 Press "CHAMBER PROBES POSITIONING" function.
- 6 Set the parameter above to "FRONT/BACK"..

If during the software upgrading the oven shows you the message “USB not found”, proceed as follows:

- 1 Format the USB stick using FAT32 system file;
- 2 If the USB stick is already FAT32 formatted, verify the CONTROL/USB board connection cable according to the following the **Figure 1**.



WRONG cable code is CE1052A0/CE1054A0 on the basis of the model you have.

CORRECT cable code is CE1052A1/CE1090A0 on the basis of the model you have.

If during the software upgrading the oven shows you the message FILE not found, proceed as follows:

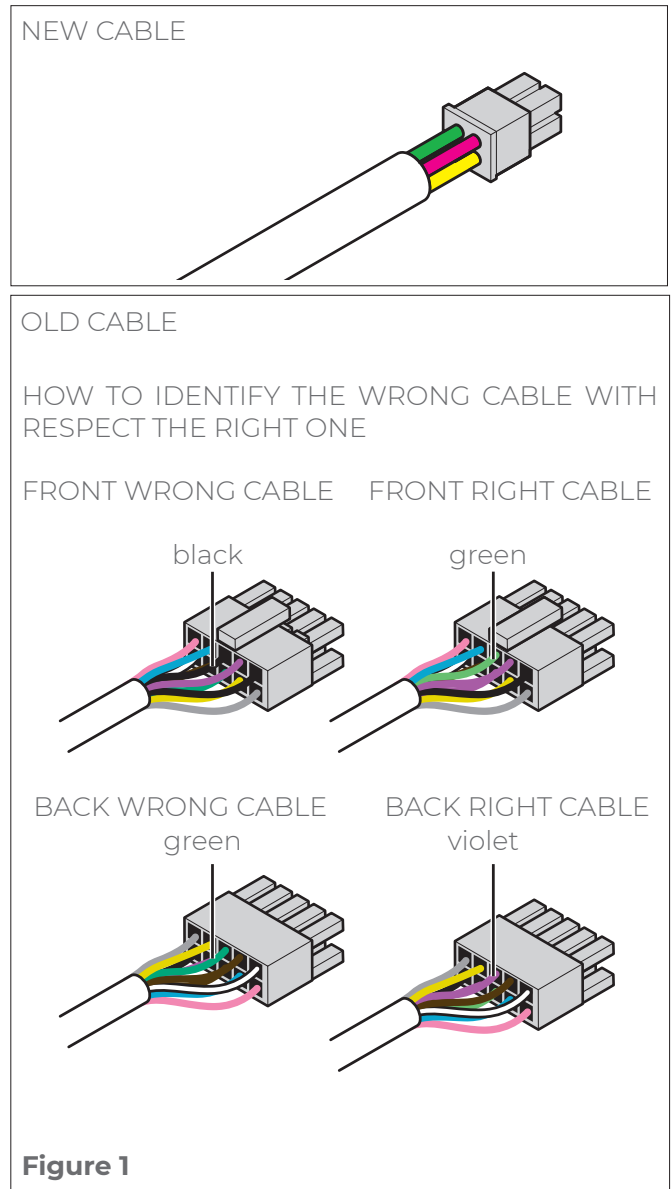
- Verify that inside the USB stick there is the UNOX-DIR folder with inside at least the Software and PARAM folders;
- Verify the proper name of the file type and name according to the electronic board that you are going to upgrade. Refer to the table below.



ELECTRONIC BOARD	FW NAME
PE2038A0 PLUS electrical ovens power board	2038.bin
PE2037A0 ONE electrical ovens power board	2037.bin
PE2021A0 PLUS EU gas ovens power board	2021.bin
PE2022A0 PLUS USA gas ovens power board	2022.bin
PE2052A0 ethernet board	2052.bin
PE2053A0 Wi-Fi board	2053.bin
 PE2054A0 EU 3G board	2054.bin
  PE2064A0 3G Asia – Australia board	2064.bin
integrate WiFi board	1057_W.bin
PE1057A0 PLUS CAPACITIVE control board	1057.bin
PE1058A0 ONE RESISTIVE control board	1058.bin
PE1062A0 BIG CAPACITIVE control board	1062.bin

Service menu user setting parameters

UNOX MIND.Maps™ ovens allow end users and technicians to adjust parameters in order to satisfy and match customer needs and requests.

This presentation aims to describe the different options and values available for each parameter.

Service menu PIN: **99857**

User menu PIN: **4456**

SERVICE MENU

Service Menu consists of 3 different sections:

- Oven Setup: it contains all the parameters concerning the oven working
- Accessories Setup: it contains all the parameters concerning the oven devices like Core and Sous- Vide probes, Smoker, Steam Boost, Pollo system, etc...
- Utilities: it contains all the PARAMETERS for the proper installation of the unit and for upgrading the software.

 According to the oven supply (electric or gas) and type of accessories connected to the unit, Service Menu will display additional parameters.

PARAMETER	DESCRIPTION	POSSIBLE OPTIONS	DEFAULT
ADAPTIVE.Cooking	It makes it possible to choose the mode of intervention of the ADAPTIVE.Cooking. When it is set to ASK EVERYTIME the ADAPTIVE.Cooking system will ask you: "ADAPTIVE.Cooking will optimize your cooking process by automatically adjusting your settings" then you can choice between YES NOW, YES ALWAYS, NO NOW, NO NEVER. When it is set to NEVER, ADAPTIVE. Cooking will never start. When it is set to ALWAYS, it will intervene every time		
AMC MODE	Activate/Deactivate the SUPER QUICK washing program. Setting AMC mode to ON, the automatic rinse cycle is deactivated	ON/OFF	OFF
BUZZER AT END OF COOK	Duration in seconds of the buzzer sound emitted at the end of a cooking program	From 5 to 3600s	45
CALIBRATION	Calibration menu. Gas Fumes tests for gas ovens (1 at higher power and 2 at lower power) and the Humidity Calibration for all the models* (to be done during installation, mandatory for ADAPTIVE.Cooking) *In the XECC-0523-EXY the humidity calibration shall not be performed. For this reason the humidity calibration function is not visible in the service menu	CALIBRATION	Calibration menu. Gas Fumes tests for gas ovens (1 at higher power and 2 at lower power) and the Humidity Calibration for all the models* (to be done during installation, mandatory for ADAPTIVE.Cooking)

CEILING/BOTTOM PROBE OFFSET	Offset of the ceiling temperature probe (expressed in Celsius degrees and multiply by 10)	from -50 to +50	O
CEILING CHAMBER PROBE OFFSET	Offset of the ceiling temperature probe (expressed in Celsius degrees and multiply by 10)	From -50 to 50	O
CHAMBER PROBE OFFSET	Degrees celsius offset of chamber probe (each 0.1 °C corresponds to 1 unit in the parameter)	From -50 to 50	O
CONSUMABLE PRICES	<p>It allows to set an unitary value of the following quantity:</p> <ul style="list-style-type: none"> ■ ENERGY PRICE ■ GAS PRICE ■ WATER PRICE ■ DETERGENT PRICE <p>In this way the oven in the consumption data section will show you the cost of the programs run.</p>	-	-
CONSUMPTION DATA IN CURRENCY	It allows to translate the quantity of the consumption data in cost	OFF/ON	OFF
CORE PROBE OFFSET	Degrees celsius offset of resistor probe (each 0.1 °C corresponds to 1 unit in the parameter)	From -50 to 50	O
CHAMBER PROBE OFFSET	Celsius degrees offset of chamber probe (each 0.1 °C corresponds to 1 unit in the parameter)	From -50 to 50	O
COMBUSTION HEAT UNIT OF MEASURE	Allow to select the unit of measurement of the heating value	kWh/smc – Mj/smc – BTU/scf	kWh/smc
COOKING BEFORE WASHING	Number of Pollo cooking programs you can run before a washing program is required (if this parameter is activate you can choose between medium or long washing cycle only)	from 1 to 99	7
CORE PROBE	<p>If it is OFF the core probe is deactivated.</p> <p>If it is MONO (standard value for ONE ovens) the oven expects to have a single point core probe.</p> <p>If it is MULTI (standard value for PLUS ovens) the oven expects to have a multi point core probe.</p> <p>Only for PLUS ovens it is possible to use a multi or mono point core probe indistinctly.</p>	OFF/MONO/MULTI	MONO (for ONE ovens)/MULTI (for PLUS ovens)

CORE PROBE OFFSET	Offset of the core temperature probe (expressed in Celsius degrees and multiply by 10)	from -50 to +50	0
DATE AND TIME	It allows to select date, time, time zone, daylight saving time function and auto-set of date and time.	-	-
DELTA TEMP PRECOOL	$\Delta T = T_{ch} - T_{sp}$ at which the pre-cooling function is stopped	10 to 40	10
DEVICE INFO	Shows model, s/n, electronic board installed and FW versions of each board		Shows model, s/n, electronic board installed and FW versions of each board
DETERGENT QUANTITY	Percentage of variation on a time based relation of the chemical pump activation	from 20 to 200	100
DRAINAGE COOLING	Activate/Deactivate the cooling of the drain (it is an extra accessory equipped with a water valve which sprays fresh water in the drain pipe)	OFF/ON	OFF
DRY.MAXI INHIBITION	Deactivation or limitation of the DRY.Maxi. If set on: OFF: standard DRY.Maxi activation Low: DRY.Maxi activation only if set to 100% HIGH: DRY.Maxi activation only during: Humidity Calibration, Cleaning Cycle, 5 seconds to the end of the cooking program.	OFF LOW HIGH	OFF
ELEC. POWER LIMIT	The oven can adjust the absorbed electrical power according to the number of turns of the heating elements activated: USE BOTH: all the 3 turns are activated (100% of the electrical power available) USE ONLY HIGH: just the external and internal turns are activated USE ONLY LOW: just the medium turn is activated The portion of power limited by using USE ONLY HIGH and USE ONLY LOW parameters depends on the distribution of power of the heating element	USE BOTH USE ONLY HIGH USE ONLY LOW	Available only on AMC mode
EXPO MODE	Activate/Deactivate the heating elements (in the electric units) or the gas system	ON/OFF	OFF
FLOOR/BACK PROBE OFFSET	Offset of the floor temperature probe (expressed in degrees celsius and multiply by 10)	from -50 to +50	0

FLOOR CHAMBER PROBE OFFSET	Celsius degrees offset of resistor probe (each 0.1 °C corresponds to 1 unit in the parameter)	From -50 to 50	0
<p>If you have a gap in the temperature reading it is possible to adjust the offset of the probes. Pay attention to fact that the parameter range is +50 to -50 that equals to +5 °C to -5 °C. Therefore if Tset - Tchamber = +3.1 °C (for instance Tset = 180 °C and Tchamber = 176,9 °C) you should set -31 in the back/bottom probe offset to compensate. Thus 0.1 °C equals to 1 in scale of values.</p> <p> PAY ATTENTION TO THE FACT THAT IF THE OVEN IS SET IN FAHRENHEIT THE PARAMETER IS STILL IN CELSIUS. REMEMBER TO CONVERT EACH TEMPERATURE VALUE IN CELSIUS BEFORE MAKING THE CALCULATION.</p> <p>The oven measures the cooking cabinet temperature by means of the temperature probe close to the fan guard at the bottom only. In the oven without the smoker device the second probe is close to the inner glass at the bottom of the chamber, while in the oven with the smoker set up it is on the ceiling of the chamber close to the fan guard. The front or ceiling temperature probe is just a backup of the back/bottom probe.</p>			
FORCE TROLLEY*	If it is ON prevents washing without trolley in trolley ovens. If it is OFF allows washing without trolley in trolley ovens *When the FORCE TROLLEY parameter is set to ON it is not possible to cook without the trolley inside the cooking chamber	OFF/ON	OFF in countertop models/ON in trolley models
FUMES MIN LIMIT TEMPERATURE	Set the lowest temperature limit of the fumes probe	from 200 to 700	360
FUMES DELTA LIMIT TEMPERATURE	Max temperature difference between fumes and the allowed value	from 10 to 200	20
GAS TYPE	Type of gas which powers the oven	G20/G25/G30/G31	G20
GRAPHICAL USER INTERFACE	It makes possible to customize the home page of the display showing, hiding, skipping, locking and deactivating the icons	OFF/ON	OFF
HEATING ELEMENT PROBE OFFSET	Celsius degrees offset of resistor probe (each 0.1 °C corresponds to 1 unit in the parameter)	From 0 to 50	0
HEATING VALUE	Parameter to set in order to consider in the gas consumption calculation the heating value of the oven	/	--
HOOD FAN DURING COOKING	It allows to switch off the hood motor during cooking. The motor switches on at the end of the cooking program or during specific step of the cleaning cycle to empty the chamber	OFF/ON	ON
HOOD HALT DELAY	Number of minutes after cooking/ washing program the hood is stopped	From 1 to 60	2
HOOD TEMP THRESHOLD	Minimum limit temperature which activates the steam condenser (Celsius degrees)	From 20 to 80	40
LANGUAGE	It allows to change the language of the oven	ENGLISH, ITALIAN, FRANCAIS, ESPANOL, DEUTSCH, CESKY, РУССКИЙ, KOREAN, SRPSKI, CHINESE, SLOVENSKY, PORTUGUÊS, JAPANESE, ROMANA, DANSK, SVENSKA, POLSKI, SLOVENŠČINA, NEDERLANDS, БЪЛГАРСКИ, ภาษาไทยΕΛΛΗΝΙΚΑ, MAGYAR, TÜRK, HRVATSKI, EESTI	ENGLISH

HUMIDITY MEASUREMENT	Oven can measure the humidity inside the cooking cabinet and accordingly adjust the climate conditions (STEAM. Maxi™ vs DRY. Maxi™)	OFF, ON	ON
LIMIT STEAM (TEMPERATURE)	The quantity of steam produced by the oven is adjusted according to the temperature set in the cooking program. By increasing the temperature set, the quantity of injected water is reduced	OFF, ON	ON
LIMIT STEAM (FAN SPEED)	The quantity of steam produced by the oven is adjusted according to the fan speed set in the cooking program. By decreasing the fan speed, the quantity of injected water is reduced	OFF, ON	ON
LIMIT STEAM (IDLE)	When no timer is activated in MULTI. Time™ mode, the quantity of steam produced by the oven is 0%	OFF, ON	ON
LOAD MODEL PARAM.	Load the corresponding parameters of the model of oven by using the file of the USB stick plugged.	LOAD MODEL PARAM.	
LOCK MANUAL COOKING	It locks the manual cooking function deactivating the relative icon on the display	OFF/ON	OFF
LOCK USER PROGRAMS	It locks the user programs preventing anyone to change the program parameters	OFF/ON	OFF
MANUAL FAT COLLECTION	Activate/Deactivate the FAT collection with the Pollo™ system	OFF/ON	OFF
MAX SPEED N. INVERS	The system doesn't make the fan reversion if the set speed is equal or less than the value of this parameter	1/2/3/4	1
MAX STEAM.BOOST TIME	It is available only in BakerTop units, this parameter manages the time of activation of Steam.BOOST	0 - 10	2
MAX PREHEATING HOLDING	Time of permanence at the set temperature only for BIG ovens	1 to 60 (minutes)	6
MINIMUM TEMP PRECOOL	$\Delta T = T_{ch} - T_{sp}$ at which the pre-cooling function is activated	60 to 260	70
NETWORK	It allows the internet connection of the oven	-	-
NUMBER OF ROTORS	Insert how many rotor arms for wasjing are in the cavity	From 1 to 3	1
NUMBER OF TRAYS	This parameter indicates the number of trays of the model	3/4/5/7 10/16/20	It depends on the number of trays of the model
PREHEATING STEAM	A maximum of 30 % STEAM.Maxi™ is produced at the end of the preheating step starting from 8 °C (14,4 °F) below the temperature set point	OFF, ON	OFF

POWER KNOCKER	The oven can reduce the maximum electrical power within the range 10–33% on the base of: 0 : no limit 1: reducing by 10-20% 2: reducing by 15-33% That parameter is for ELECTRICAL UNITS only. It prevents the glowing of the heating elements. It works both during cooking and washing cycle	0 1 2 3 4 5 6	0
RESET THE FACTORY DEFAULT	Reset the all parameters to the factory value	RESET THE FACTORY DEFAULT	reset all the parameters to the factory value
SCALE INVERSION	The frequency of the fan reversion is a function of the step duration, for steps which lasts more than 15 minutes the inversion of the fans occurs every 3' 20" minutes instead of 2 minutes (standard value)	OFF/ON	OFF
SHOW FULL MENUS	The oven shows you the full list of parameter independently by the model except for TEMPERATURE BOOST, SMOKER for baker ovens, STEAM OFF/ ON BOOST for chef ovens	OFF/ON	OFF
SMOKER	Activate/Deactivate the SMOKER accessory	OFF/ON	OFF
SOUS VIDE PROBE OFFSET	Offset of sous vide probe (expressed in degrees celsius and multiply by 10)	From -50 to 50	0
STEAM BOOST	Activate/Deactivate the STEAM BOOST accessory	OFF/ON	OFF
UNIT OF MEASURE	It allows to set the unit of measure of the following quantity: <ul style="list-style-type: none"> ■ Temperature ■ Volume ■ Thickness ■ Weight ■ Energy ■ Steam.BOOST supply ■ Currency 	TEMPERATURE ▶ °C - °F VOLUME ▶ litres – gallons THICKNESS ▶ mm –In WEIGHT ▶ kg – lbs ENERGY ▶ kWh – BTU Steam.BOOST SUPPLY ▶ g – cc –fl.oz CURRENCY	
UNOX.CARE	It allows to activate/reset the liter counter of the UNOX. PURE and UNOX. PURE-RO. To activate the liter counter of the UNOX.Pure it is necessary the PIN attached to the external brown box of the kit	UNOX.PURE ▶ REMAINING VOLUME WATER HARDNESS ACTIVATE COUNTER UNOX.PURE-RO ▶ REMAINING VOLUME ACTIVATE COUNTER RESET COUNTER	
UPGRADE SOFTWARE	Upgrade function for all board firmwares	UPGRADE SOFTWARE	Upgrade function for all board firmwares
UPSCALE GAS BLOWER	Scale up to 400% of the minimum of the gas blower	100 to 400	100

USB

It allows to EXPORT PROGRAMS, IMPORT PROGRAMS, IMPORT PICTURES

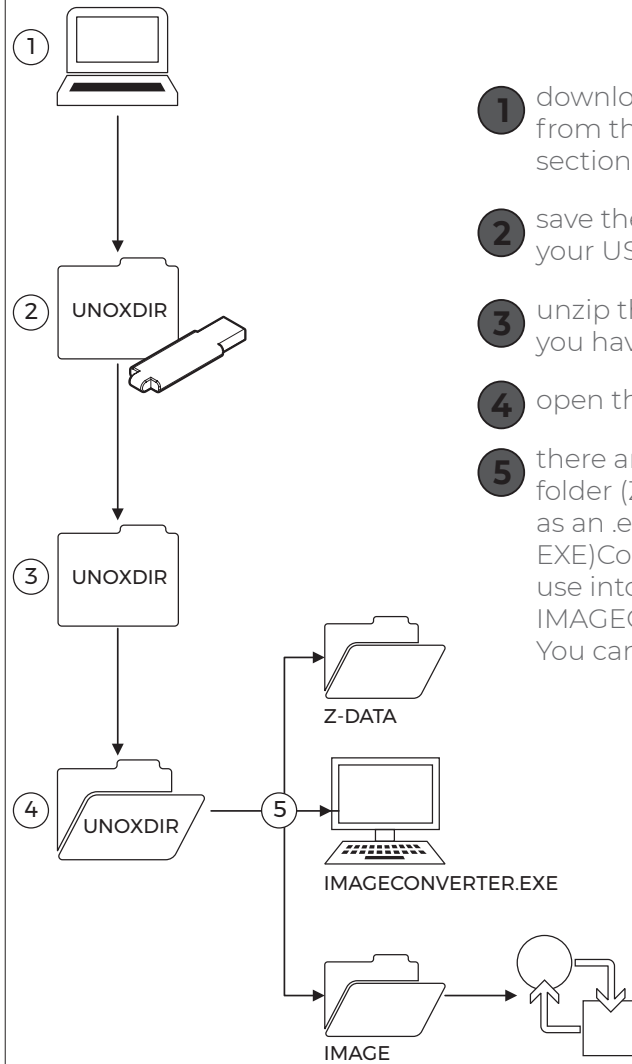

- 1 download the UNOXDIR.zip folder from the UNOX Infonet software section
- 2 save the UNOXDIR.zip folder onto your USB stick
- 3 unzip the UNOXDIR.zip folder that you have just downloaded
- 4 open the UNOXDIR folder
- 5 there are two folders within this folder (ZDATA and IMAGES) as well as an .exe file (IMAGECONVERTER.EXE) Copy the images you want to use into the IMAGE folder. Start the IMAGECONVERTER.EXE program. You can now use the images.

To load the own pictures the USB stick needs to be properly configured:

To import the pictures in the oven proceed as follows:

- Enter the USER MENU;
- Tap the PIN 4456;
- Press USB function;
- Press IMPORT PICTURES.

USE FUMES PROBE	Activate/Deactivate the use of the fumes probe	ON/ OFF	ON
WASHING BEFORE HOOD	Number of washing cycles run by the oven before starting a hood washing	From 0 to 999	0
WASHING DIAGNOSTIC	Activate/Deactivate the reading of the pressure switch placed in the washing system	ON/OFF	ON
WASHING VALVES TYPE	To choose the type of solenoid valves used in the washing circuit	NORMAL / SELF – CLEANING	NORMAL
WATERLESS MODE	The steam setting bar in the manual cooking program is deactivated	ON/OFF	OFF

STEAM.Maxi™ - DRY.Maxi™

Introduction.....66
 STEAM.Maxi™67
 DRY.Maxi™69

INTRODUCTION

The steam production is based on a cycle of opening and closing of the steam solenoid valves which lasts 26 seconds totally.

This cycle is divided into 13 single steps of 2 seconds each, where the valve can be **open** (status 1) or **closed** (status 0).The climate conditions can be set as reported in **Table 6**:

Table 6
 STEAM.Maxi™ and DRY.Maxi™ working conditions

Clima	Minimum set point	Maximum set point
STEAM.Maxi™	0%	100%
DRY.Maxi™	0%	100%

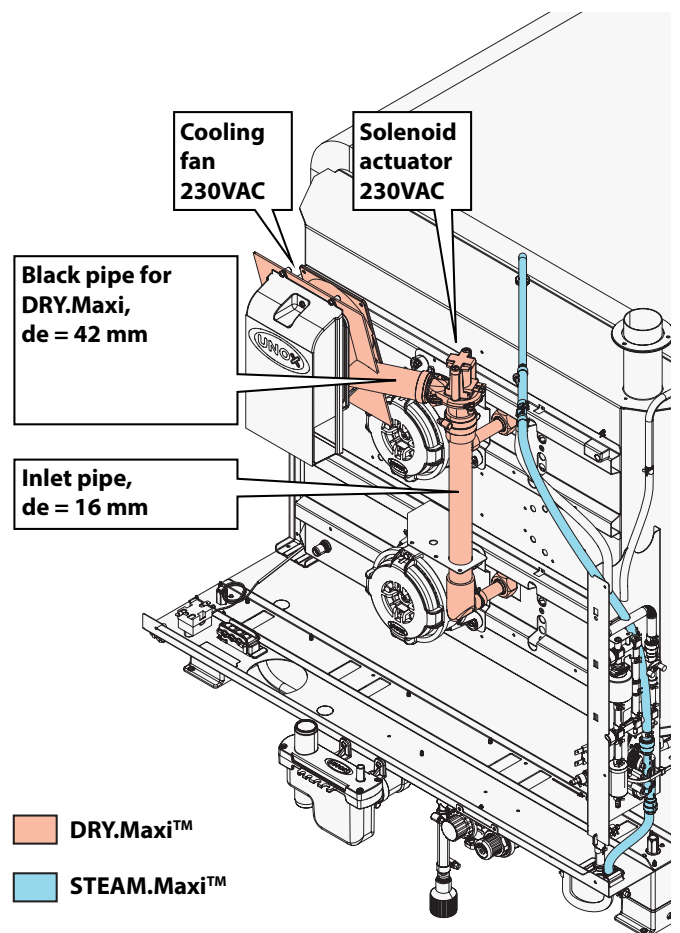

Figure 3
 Steam.Maxi™ - Dry.Maxi™

STEAM.MAXI™

UNOX STEAM.Maxi™ technology carries out every type of steaming process, even the most delicate ones starting from a temperature of 35 °C (95 °F).

This result is possible thanks to a production of steam that is up to 3 times superior to that obtained with traditional direct injection ovens when using the same amount of water.

The result is identical to, if not even better, than that obtained when using a boiler combi oven.

► Open loop system

In case of Humidity Measurement parameter set to OFF, the oven works with an open loop control system: the value of STEAM.Maxi™ set by the user corresponds to the amount of relative humidity reported on **Table 7**:

Table 7

Correlation of STEAM.Maxi™ set point and the value with which the oven works

STEAM.Maxi™ setting (%)	STEAM.Maxi™ setting provided (%)
0	30
10	30
20	40
30	40
40	50
50	50
60	60
70	70
80	80
90	90
100	100

Each oven is equipped with one double solenoid valve to produce steam. The valve is supplied at 230 V AC and consists of two different valve bodies, as shown in **Figure 4**, (EV1, lowest water flow rate and EV2, highest water flow rate) which allow to adjust the water flow rate according to the climate conditions of the cooking chamber.

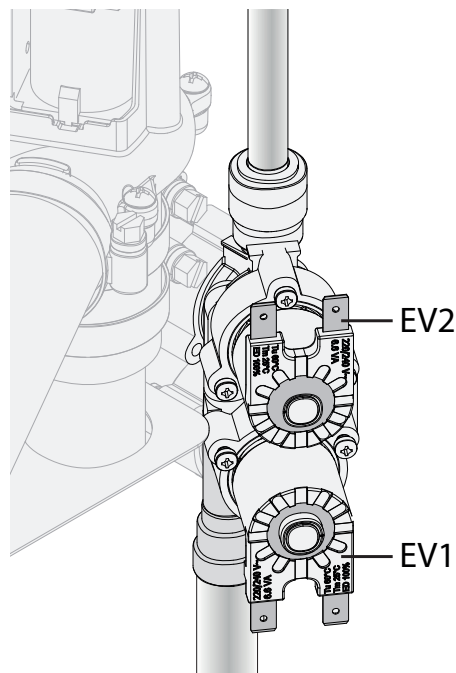

Figure 4

Solenoid valves to produce steam

The solenoid valve EV1 is the first one to be activated in order to have the valve body with the smallest flow rate activated for a longer time. This avoids a repetitive closing and opening of the second solenoid valve.

The water solenoid valves are activated according to 14 steam tables.

Note:

In all the conditions listed below the oven always works with an open loop control system:

- During the first production of steam (as specified below in the chapter **STEAM.Maxi™ set to 100%**);
- If $T_{sp} < 70\text{ °C}$ (158 °F) or $T_{sp} > 200\text{ °C}$ (392 °F) (T_{sp} = Set Point Temperature);
- Pulse mode
- If DRY.Maxi™ is set to 100%;
- If STEAM.Maxi™ is set to 0% and ADAPTIVE. Cooking™ is OFF
- During the preheating step, any washing programs, the humidity calibration and the fumes tests;
- If the oven triggers the error WF04.

► Closed loop system

In case of Humidity Measurement parameter set to ON, the timing of the opening of the solenoid valves is proportional to the difference between the humidity value set point, Hsp and the relative humidity value measured, Hm.

Therefore, the steam tables are chosen according to this feedback control, figured in **Figure 5**.

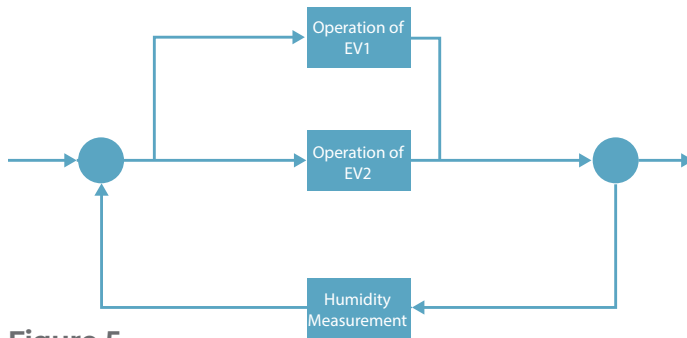

Figure 5
Closed-loop system in STEAM.Maxi™

► STEAM.Maxi™ set to 100%

When STEAM.Maxi™ is set to 100%, the system records the number of consecutive times in which the cooking chamber has reached the saturation level. If this value is 3, the system switches off the steam solenoids to provide the steam table of 5% according to the oven model.

Assumption: For a specific temperature, the range of RPM between dry conditions and saturated conditions (calculated during the humidity calibration) is subdivided into a specific number of classes. For each class, a number of RPM and a specified humidity amount have been defined

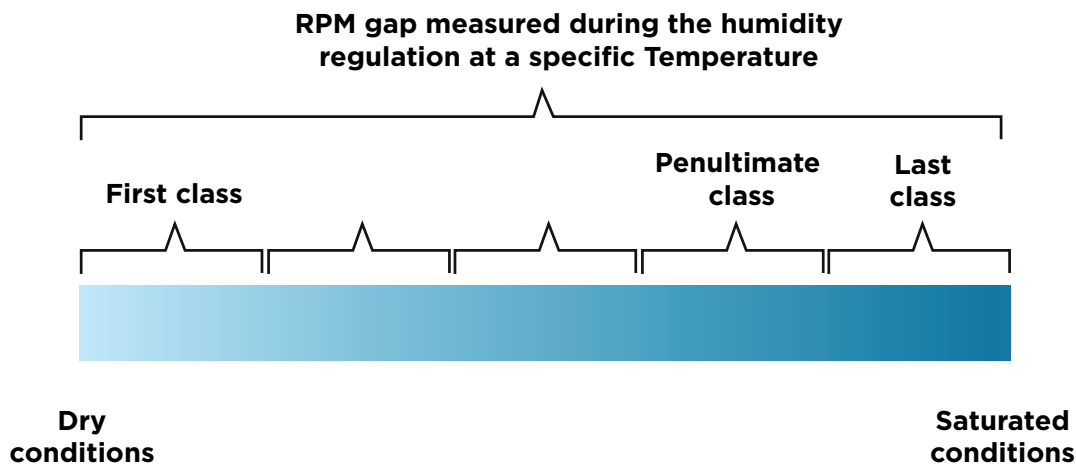

Figure 6
Classes of RPM defined at a specific temperature

In the case of STEAM.Maxi™ set to 100%, the oven starts producing a quantity of steam which corresponds to the value of 100% of the oven steam table. Once the first measurement of the humidity has been done, the quantity of steam is increased or decreased by 20% according to the following rules:

- If the relative humidity measurement, Hm, does not fall into the penultimate class, the quantity of steam is increased by 20%.
- If the relative humidity measurement, Hm, is 100% or if the four consecutive measurements of humidity fall into the penultimate class, the quantity of steam is reduced by 20%.

DRY.MAXI™

DRY.Maxi™ technology rapidly extracts humidity from the cooking chamber and creates the ideal conditions for food that needs to be cooked in a completely dry environment. Oven baked products are soft, crisp and fragrant, grilled and browned meats retain their weight and flavour, vegetables maintain their perfect consistency. You can cook whatever you like, with Unox, quality comes as standard.

DRY.Maxi™ technology consists of a solenoid actuator fed at 230 V AC connected to the power board. Its function is to extract humidity from the cooking chamber, as shown in **Figure 7**.

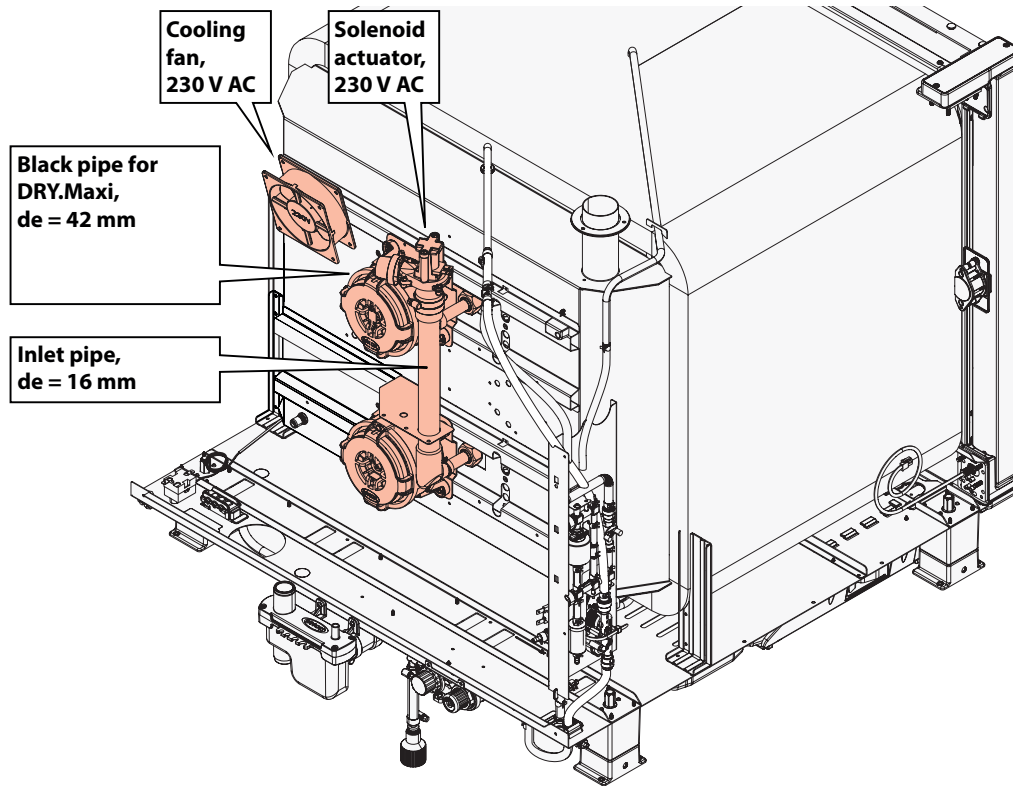

Figure 7
DRY.Maxi™ technology

When the DRY.Maxi™ solenoid actuator is open, the fresh and dry air at room temperature is forced inside the cooking chamber by the cooling fan, pushing out the wet and hot air through the chimney.

► Open loop system

The DRY.Maxi™ solenoid actuator follows a 26 second pattern. This is the same for all oven models, but it depends on the DRY.Maxi™ set point as seen in **Table 8**.

Table 8
DRY.Maxi™ scheme

DRY Maxi™	2s	4s	6s	8s	10s	12s	14s	16s	18s	20s	22s	24s	26s
10%	1	1	0	0	0	0	0	0	0	0	0	0	1
20%	1	1	1	0	0	0	0	0	0	0	0	1	1
30%	1	1	1	1	0	0	0	0	0	0	0	1	1
40%	1	1	1	1	1	0	0	0	0	0	0	1	1
50%	1	1	1	1	1	1	0	0	0	0	0	1	1
60%	1	1	1	1	1	1	1	0	0	0	0	1	1
70%	1	1	1	1	1	1	1	1	0	0	0	1	1
80%	1	1	1	1	1	1	1	1	1	0	0	1	1
90%	1	1	1	1	1	1	1	1	1	1	1	1	1
100%	1	1	1	1	1	1	1	1	1	1	1	1	1

► Closed loop system

The timing of the DRY.Maxi™ valve meets the data reported on **Table 8**. Every time the humidity measurement is greater than 30%, the DRY.Maxi™ setting of the table above is increased by 20%. After this first adjustment, every time the humidity reading is less than 30% the DRY.Maxi™ is reduced by 20%. If the DRY.Maxi™ is set to 100%, the DRY.Maxi™ solenoid actuator is always open.

First step of DRY.Maxi™/ STEAM.Maxi™

In order to activate/deactivate the DRY.Maxi™ or STEAM.Maxi™ system according to the real climate conditions of the cooking chamber, a first measurement of humidity is required. Since this first humidity reading is done after running the oven for 20 seconds, in the first 20 seconds the DRY.Maxi™ or STEAM.Maxi™ technology works in open loop system, except when STEAM.Maxi™ is set to 100%. In this case the setting of STEAM.Maxi™ switches to 40%.

Limitations

Temperature is the limiting factor for maximum steam productions as shown below in **Table 9**.

Temperature Limitation

According to the Temperature Set Point there is a limit of the steam production, as shown in **Table 9**. The aim is to prevent the steel of the cooking chamber from any thermal shocks and to reduce the quantity of water injected at low temperature since the production of steam is quite limited in that condition.

Table 9

Temperature Limitation on the steam production

Temperature [°C]	Limitation Factor (Steam produced)
$T_{sp} < 60\text{ °C}$ (140 °F)	10%
60 °C (140 °F) $\leq T_{sp} < 70\text{ °C}$ (158 °F)	20%
70 °C (158 °F) $\leq T_{sp} < 80\text{ °C}$ (176 °F)	30%
80 °C (176 °F) $\leq T_{sp} < 90\text{ °C}$ (194 °F)	50%
90 °C (194 °F) $\leq T_{sp} < 100\text{ °C}$ (212 °F)	70%
100 °C (212 °F) $\leq T_{sp} < 120\text{ °C}$ (248 °F)	100%
120 °C (248 °F) $\leq T_{sp} < 140\text{ °C}$ (284 °F)	50%
140 °C (284 °F) $\leq T_{sp} < 240\text{ °C}$ (464 °F)	30%
$T_{sp} \geq 240\text{ °C}$ (464 °F)	20%

For instance, at 110°C (230 °F), if you set the STEAM.MAXI™ to 50%, the steam production is 50% of the maximum available. At 85°C (185 °F) instead, it means that the real steam production will be 25%.

Speed motor Limitation

The speed of the motor limits the quantity of steam that can be produced, as shown in **Table 10**. At lower speeds the quantity of water that can be vaporized by the fans is lower than at maximum speed.

Table 10

Speed motor Limitation

Speed	Limit factor
1	30%
2	50%
3	80%
4	100%

MULTI.Time™ Limitation

If a MULTI.Time™ program is running and there are no timers activated the oven limits the injection of steam at 10%.

AIR.Maxi™ technology ensures perfect distribution of the air and therefore of the heat within the cooking chamber. Multiple auto-reversing fans and high speed motors guarantee cooking uniformity in all pans: from those at the bottom of the oven to those at the top. The possibility of choosing from 4 air speeds and 4 semistatic modes allows any type of product to be cooked perfectly, from the most delicate items to products that require high temperatures and a high rate of heat transfer.

► Motor

In the convection oven, the motors are used for forcing the circulation of the air around food at different speeds. The motor used is a single phase with asynchronous and it uses a system of capacitors and a triac device integrated on the power board to reverse the rotation. The stator winding is powered by a sinusoidal voltage and it is crossed by a sinusoidal current that generates an alternative sinusoidal e.m.f (electromotive force). The sinusoidal current produces an alternate magnetic field; that field could be considered as the overlap of two magnetic fields with the same value. This value corresponds to the half of the maximum of each alternate field. If the motor starts in a direction, it will continue to run in that direction accelerating up to the maximum speed. That phenomenon is due to the fact that the torque of the field, spinning in the same direction of the motor is greater than the other one. To kick the motor UNOX AIR.Maxi™ technology uses a capacitor. The motor has a high starting torque. The aim of the capacitor is to create a difference of $\pi/2$ in the sinusoidal phase feeding the turns inside the motor. In that way a double phase rotating field is generated as shown in **Figure 8**.

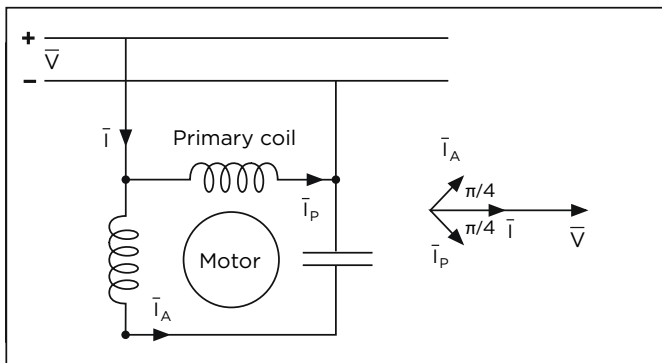

Figure 8
Asynchronous single phase motor scheme

The UNOX motor is equipped with two turns: one is the primary and the other is the auxiliary and vice versa on the basis of which the electrical current passes through first.

The triac on the power board has the aim to switch the current between the two turns ensuring the inversion of the rotation.

In the electrical scheme of the MIND.Maps™ ovens, the motors are connected in parallel. For each motor, a capacitor has been installed and connected in series with the motor itself and in parallel with the other capacitors.

► Braking element

The asynchronous single phase motor runs at maximum speed at standard voltage, normally 230 V AC 50 Hz for European market, 208-240 V AC 60 Hz for the US. At this voltage, the motor runs at around 2700-3000 RPM.

In order to slow down the motor, UNOX uses two different braking elements: each of them is a resistance connected in series with the motor and able to drop the supply voltage to the motor itself.

The braking elements have the following technical specifications:

- Braking element 1 (yellow wires) $R = 75 \Omega$, 147 W, 105 V
- Braking element 2 (red wires) $R = 37,5 \Omega$, 100 W, 60 V

The oven can manage 4 regular speeds in addition to 4 pulse speeds by alternatively activating the braking elements. This is according to the scheme summarized in **Table 12**.

Table 12

Braking element activation for speed adjustment (0 stands for resistance not activated, 1 stands for resistance activated)

Speed	Braking element 1 (Yellow)	Braking element 2 (Red)
v 4 (max)	R1 = 0	R2 = 0
v 3	R1 = 0	R2 = 1
v 2	R1 = 1	R2 = 0
v 1 (min)	R1 = 1	R2 = 1

► Speed regulation

The fan can spin in four different regular speeds and four pulse speeds. These speeds are equivalent in terms of RPM, but in the pulse mode the fan spins only when the heating element are turned on. Temperature and humidity measurement are the limiting factors for the fan speed as reported in **Table 13**. The power board applies a sinusoidal cut of the phase when the oven is running at speed 4 and it is going to measure the climate conditions of the cooking chamber. The sinusoidal cutting is not applied when the motor is running in normal conditions out of the humidity measurement.

Table 13
Speed limits

Speed	R1	R2	Synusoidal cutting operating (LP _{standard use})*	Synusoidal cutting measuring (LP _{measurement})**	RPM @ 100 °C (212 °F) at 50Hz	Range
4	0	0	1023	523/723	2750	30 °C–260 °C/ 86°F-500°F
3	0	1	1023	1023	2200	30 °C–260 °C/ 86°F-500°F
2	1	0	1023	1023	1500	30 °C–230 °C/ 86°F-446°F
1	1	1	1023	1023	900	90 °C–200 °C/ 194°F-392°F

⚠ At maximum speed and at 60 Hz, the motor can run at a maximum of 3300 RPM.

*LP_{standard use}: Leading-edge phase in standard use, the table shows how many bits are activated during a feeding cycle of the motor in working conditions.

**LP_{measurement}: Leading-edge phase during the measurement; the measurement of the speed 4 during the humidity measurement, is performed by activating 523 of the 1023 bits only (723 at 60 Hz)

► Fan speed vs Temperature

Temperature is the limiting factor for the ventilation as reported in **Table 14**.

⚠ These limitations are not used during the HUMIDITY CALIBRATION.

Table 14
Temperature limits

Minimum Speed	Temperature	
V1	$T_{ch} > 90\text{ °C (194 °F)}$	$T_{sp} < 200\text{ °C (392 °F)}$
V2	$T_{ch} > 30\text{ °C (86 °F)}$	$T_{sp} < 230\text{ °C (446 °F)}$
V3	$T_{ch} > 30\text{ °C (86 °F)}$	$T_{sp} = T_{limit}$
V4	$T_{ch} > 30\text{ °C (86 °F)}$	$T_{sp} = T_{limit}$

T_{sp} : Set point temperature or, when working with the core probe, T_{sp} is $\Delta T + 120\text{ °C}$.

T_{ch} : Cooking chamber temperature.

T_{limit} : 260 °C (500 °F), 300 °C (572 °F) for High Temperature ovens.

► Timing

The ventilation works on a 100 seconds time basis pattern. At the end of this time the motor reverses the sense of rotation with 3 exceptions:

- Maximum steam, 100 % STEAM.Maxi™: the motor does not make the reversion in the range $70\text{ °C (158°F)} < T_{sp} < 130\text{ °C (266°F)}$.
- MAX SPEED N. INVERS. Parameter: if the set speed is equal or less than the value of this parameter, the motor does not reverse the sense of rotation.

- **SCALE INVERSION** parameter: the motor does make the inversion, but on the base of the current cooking step duration, as reported in Table 15.

Table 15
Scale inversion parameter

Step duration	Time base
< 16'	100
<32'	200
>32'	300

For the inversion of the motor there are 3 seconds of pause to allow the stabilization of the motor after the activation of the triac on the power board. Every 17 seconds the oven performs the humidity and speed measurement.

► Motor working status

The status of the ventilation is summarized in **Table 16** and described below.

Table 16
Motor working status

Status	Input	Output	Features
Motor inactive period	Braking step finished	No alarm triggers	LP=0
Motor start-up	Required	3" timer ends	LP = max
Steady state	Starting ended	Humidity measurement	LP from Table 2
		Motor has to make the inversion	
		17" timer starts	
Humidity measurement	17" standard use timer expired	6" timer starts	LP _{measurement}
Braking step	Inversion requested	-	-
	Speed change requested		

Motor inactive period

The motor does not spin if there is any alarm or when the pulse mode is requested and the heating elements are off.

Motor start up

If the ventilation is requested and pulse mode allows it, the system is ready to start.

The inversion (100 seconds) and the stabilization (3 seconds) timers start up.

⚠ Note for the first start: if the speed is set to 1, the fan starts at speed 2 until the cooking chamber reaches 90 °C (194°F).

Steady state

Once the motor speed stabilizes after the required 3, the humidity measurement timer of 17" starts. The humidity measurement takes 6".

Braking step

The oven brakes when:

- A motor revolution inversion is requested (every 100")
 - A change of motor speed is requested or in pulse mode (the fan slows down and stops if the pulse mode is selected and the heating system is off).
- The braking of the motor requires the inversion of the polarization of the motor and the activation of both the resistances, R1 and R2. If after 10 seconds the motor speed is greater than 200 RPM or if the tachometer is damaged, the motor switches off.

Humidity measurement

If the parameter HUMIDY MEASUREMENT is set to ON, the humidity reading inside the cooking chamber is if the following conditions are met:

- Every 20 seconds of working at standard use (not during the washing program, preheating step and fumes test);
- If the motor is not in pulse mode;
- If the temperature in the cooking chamber is 70 °C (158 °F) ≤ Tch ≤ 200 °C (392 °F);
- If the tachometer is working properly;
- After the first 20 seconds from any change of the motor speed.

► Method applied for the humidity measurement

The humidity measurement is a function of the air density and temperature.

The humidity measurement is performed by measuring the RPM of the motor with the tachometer.

At speed 4, if $LP_{\text{measurement}} \neq LP_{\text{standard use}}$, the system considers the instantaneous speed of the motor at the end of the 6 second stabilization period.

Otherwise, for the other speeds, the system considers the average of the readings of the tachometer, v_m , along the same time frame (6").

The output data are the motor speeds in saturated and dry conditions, v_{sat} and v_{dry} calculated at T_{ch} through a linearization of the data registered during the humidity calibration in saturated and dry conditions, speed data are collected at 100 °C (212 °F), 120 °C (248 °F), 140 °C (284 °F) and 180 °C (356 °F)'.
If the humidity calibration has not been done, the system works in an open loop system.

v_{sat} and v_{dry} registered during the humidity calibration are corrected according to the frequency and the supply voltage.

Self cleaning solenoid valves

ROTOR.KLEAN

► Introduction

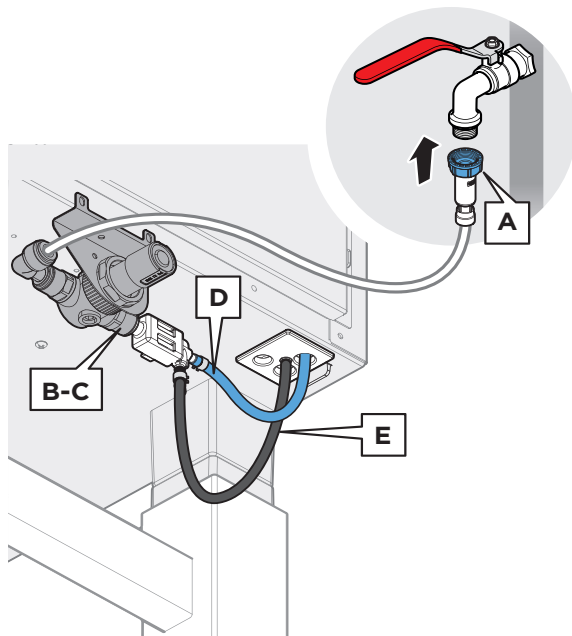

WATER INLET SYSTEM AFTER FEBRUARY 2020

The water inlet system is composed of:

- A) Input filter 3/4" with non-return valve + mechanical filter of 100 µm;
- B) One pressure reducer set at 2.3 bar / 29 psi) (not adjustable);
- C) One water main connection pipe made of white LDPE (de = 10 mm - 0,4 inches);
- D) Cleaning system fed by the blue pipe made of EPDM (de = 12 mm - 0,31 inches);
- E) Black pipe for steam EPDM (de = 12 mm - 0.31 inches);
- F) Connection to the detergent tank black LDPE (de = 10 mm - 0,4 inches).

Figure 9

Water inlet after February 2020

WATER INLET SYSTEM BEFORE DECEMBER 2016 (see Figure 1)

The water inlet system is composed of:

- A) Input filter 3/4" with non-return valve;
- B) One mechanical filter of 100 µm;
- C) One pressure reducer set at 2.3 bar / 29 psi) (not adjustable);
- D) One water main connection pipe made of white LDPE (de = 10 mm - 0,4 inches);
- E) Cleaning system fed by the blue pipe made of LDPE (de = 8 mm - 0,31 inches);
- F) White pipe for steam LDPE (de = 8 mm - 0.31 inches);
- G) Connection to the detergent tank black LDPE (de = 10 mm - 0,4 inches).

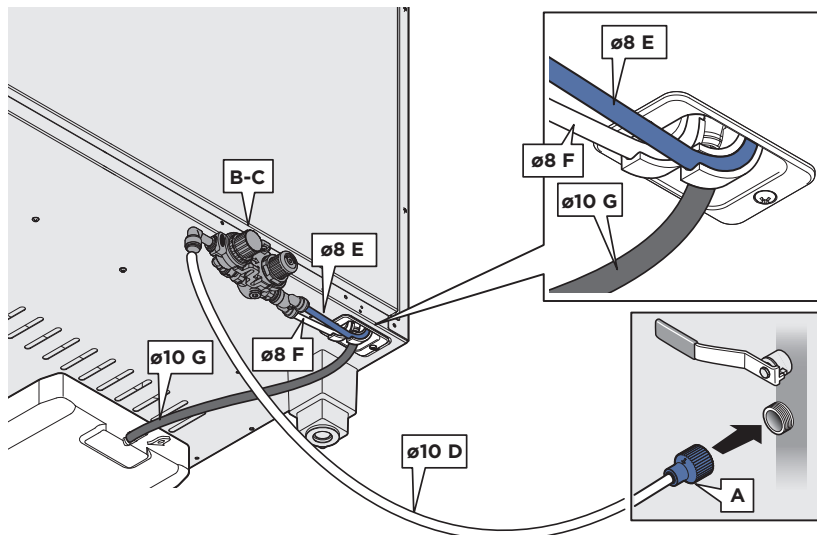

Figure 10

Water inlet before December 2016

WATER INLET SYSTEM AFTER DECEMBER 2016

The water inlet system is composed of:

- A) Input filter 3/4" with non-return valve;
- B) One mechanical filter of 100 µm;
- C) One pressure reducer set at 2.3 bar / 29 psi (not adjustable);
- D) One water main connection pipe made of white LDPE (d=15mm 0,6 inches)
- E) For Plus and One models one Cleaning system fed by the blue pipe made of LDPE (d = 12 mm - 0,47 inches)
- F) EPDM 12 mm black pipe for steam (d = 12 mm - 0,47 inches)
- G) Connection to the detergent tank black LDPE (d = 10 mm - 0,4 inches)

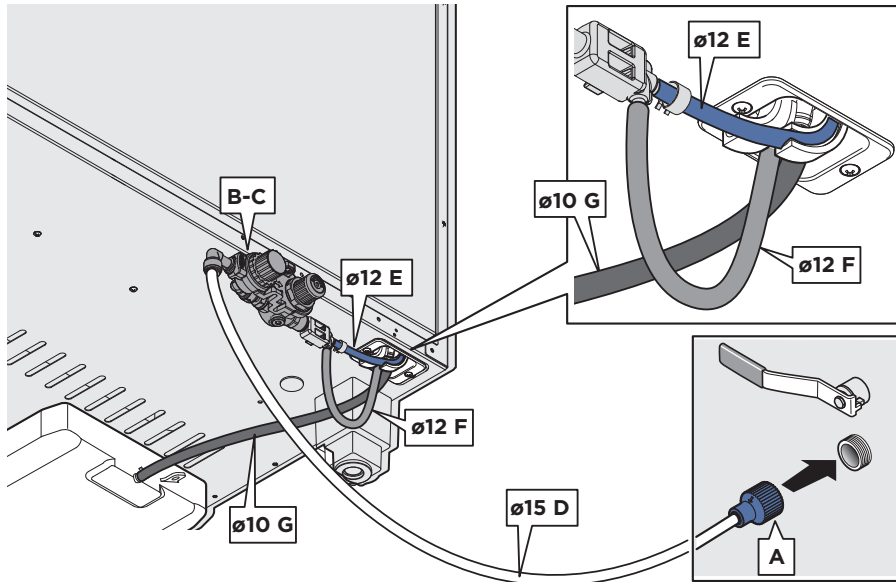

Figure 11

Water inlet after December 2016

► Detergent tank

Figure 12 CHEFTOP-BAKERTOP MIND.Maps™ PLUS and ONE oven are equipped with a chemical tank installed underneath the oven. CHEFTOP MIND.Maps™ Compact Ovens' detergent tank is inside the oven structure.

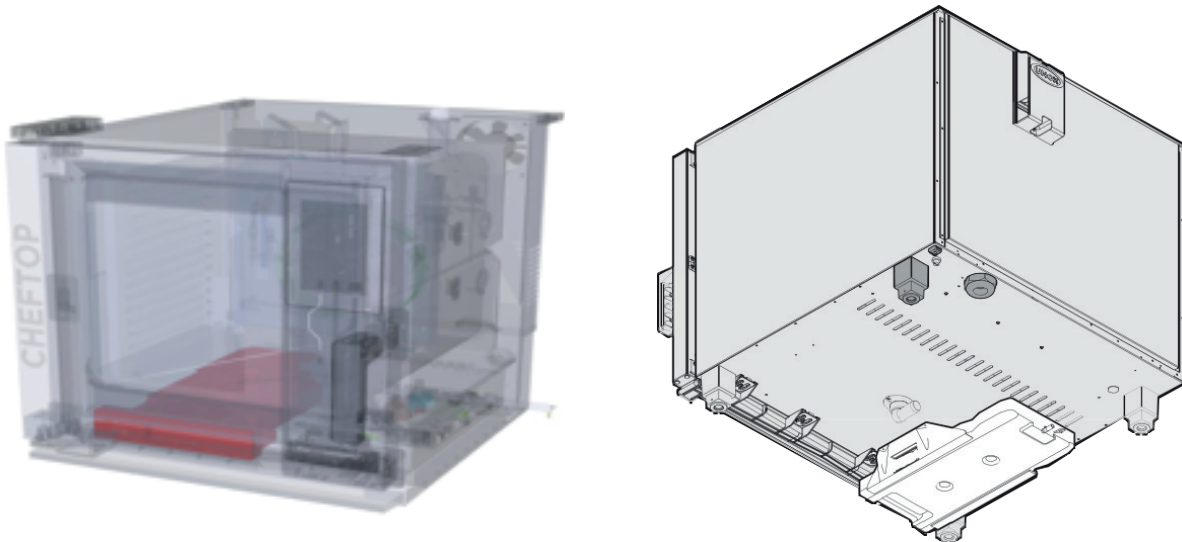

Figure 12

CHEFTOP MIND.Maps™ Compact

CHEFTOP MIND.Maps™

The tank capacity changes according to the oven model:

- 3 l + 0,8 l of reserve (0,66 gal + 28,15 floz)
- 2 l + 0,8 l of reserve (0,44 gal + 28,15 floz) only for compact oven

► Self cleaning solenoid valves (scsv)

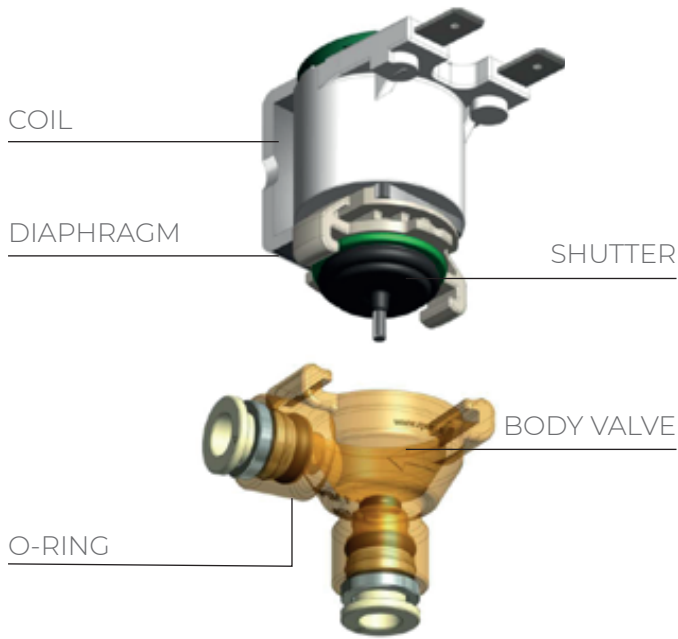

Starting from December 2019 the MIND.Maps™ ovens will be equipped with a new **washing solenoid valve group (Figure 13)**. The new washing circuit will have new Self Cleaning Solenoid Valves (SCSC).

Figure 13
Self cleaning solenoid valves

Self Cleaning solenoid valves have the most simple working principle. The flow passes through a small orifice that can be closed off by a plunger with a rubber gasket on the bottom. A small spring holds the plunger down to close the valve. The plunger is made of a ferromagnetic material. An electric coil is positioned around the plunger. As soon as the coil is electrically energized, a magnetic field is created which pulls the plunger up towards the center of the coil. This opens the orifice so that the medium can flow through.

Keep in mind that whenever you change a new washing circuit with Self Cleaning solenoid valves select the correct number of rotors in Service Menu>Washing>Number of Rotors according to the serial number and select the washing valve type. To ensure that the oven runs the correct washing program in terms of durations and consumptions.

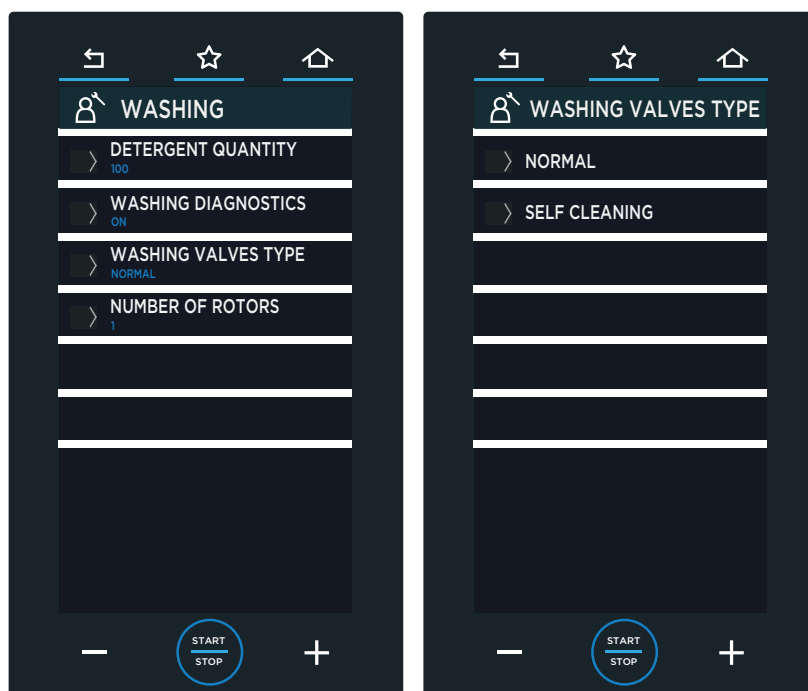

Figure 14

► Single rotor arm CHEFTOP-BAKERTOP MIND.Maps™, PLUS ovens

The MIND.Maps™ PLUS countertop ovens with one rotor arm have a washing circuit as illustrated below.

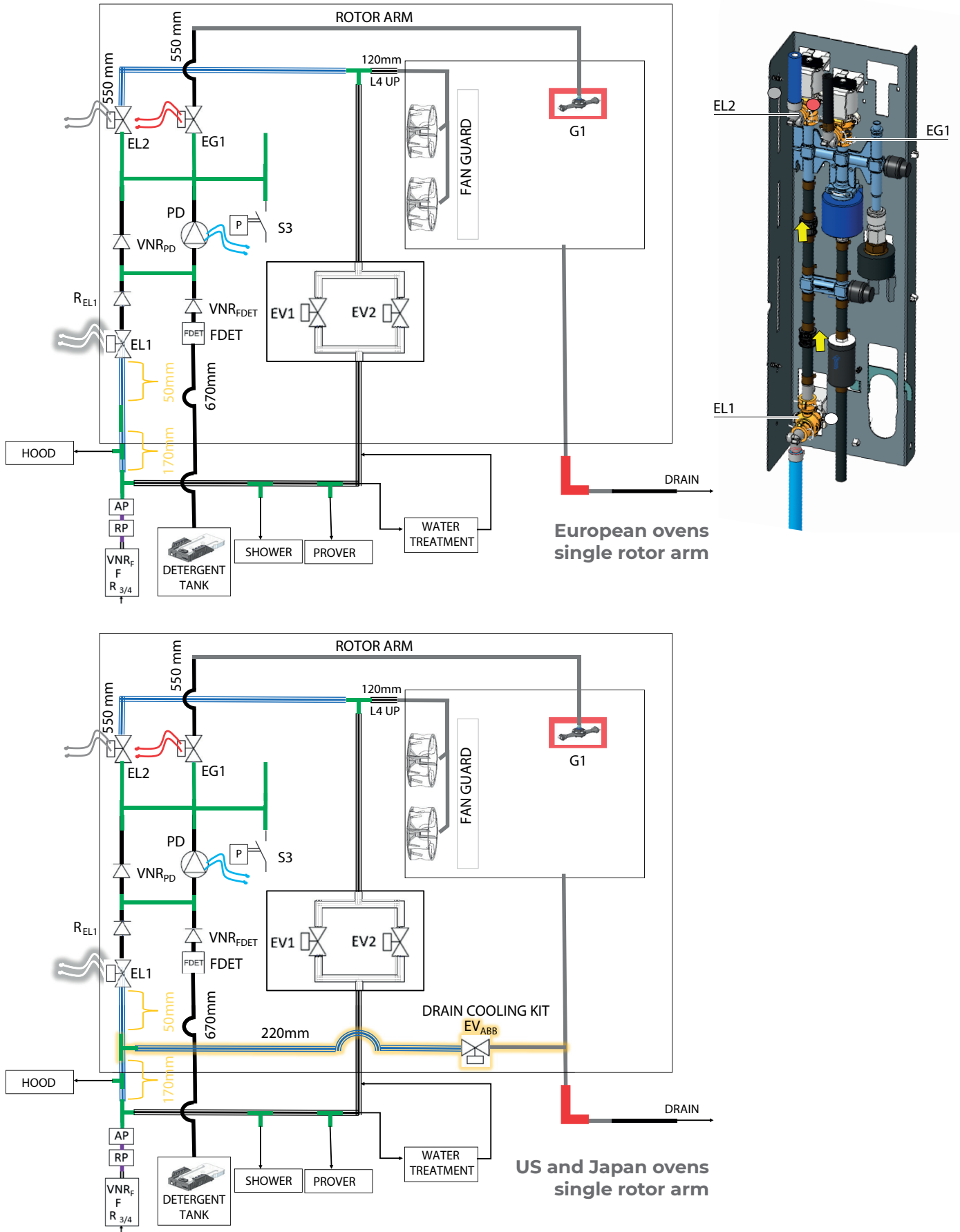

Figure 16

► 2 rotor arms CHEFTOP-BAKERTOP MIND.MapTM, PLUS ovens

The MIND.MapTM PLUS floor standing ovens 16EU and 20 GN1/1 with two rotor arms have a washing circuit as illustrated below.

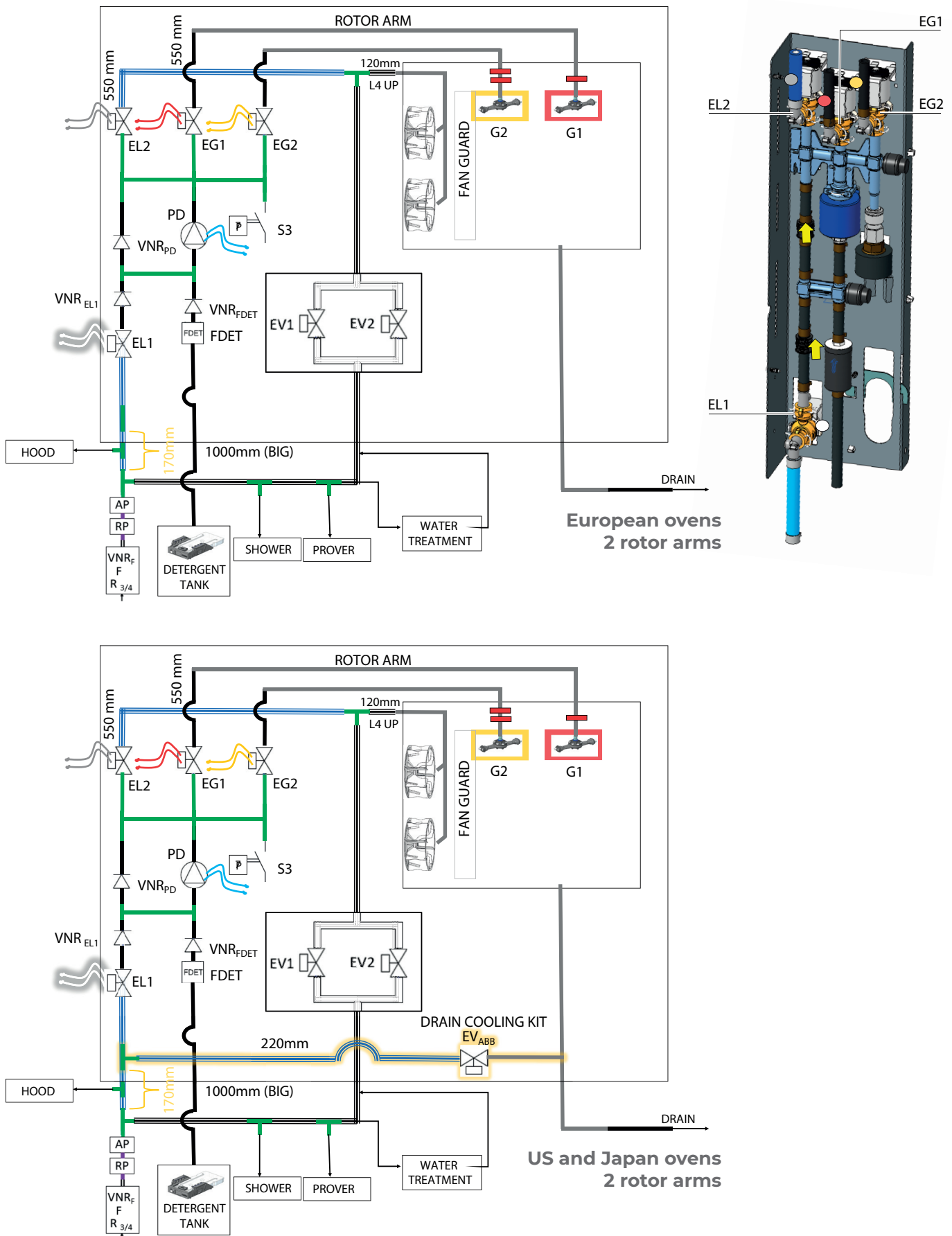

Figure 17

▶ 3 rotor arms CHEFTOP-BAKERTOP MIND.MapS™, PLUS ovens

The MIND.MapS™ PLUS floor standing trolley ovens 20 GN 2/1 and 16FS and new 06 GN2/1 and 10 GN2/1 have three rotor arms with a washing circuit as illustrated below. As the system has 3 valves and 3 rotor arms, EG1 is shared with back fan guard cleaning and with G1 rotor arm. As the rotor arm has two nozzles to spray detergent and water solution inside the cooking chamber; these nozzles implicate backpressure. Therefore the line of the back fan guard cleaning has a flow restrictor on to equalize the pressure and avoid all the water going to the fan nozzles.

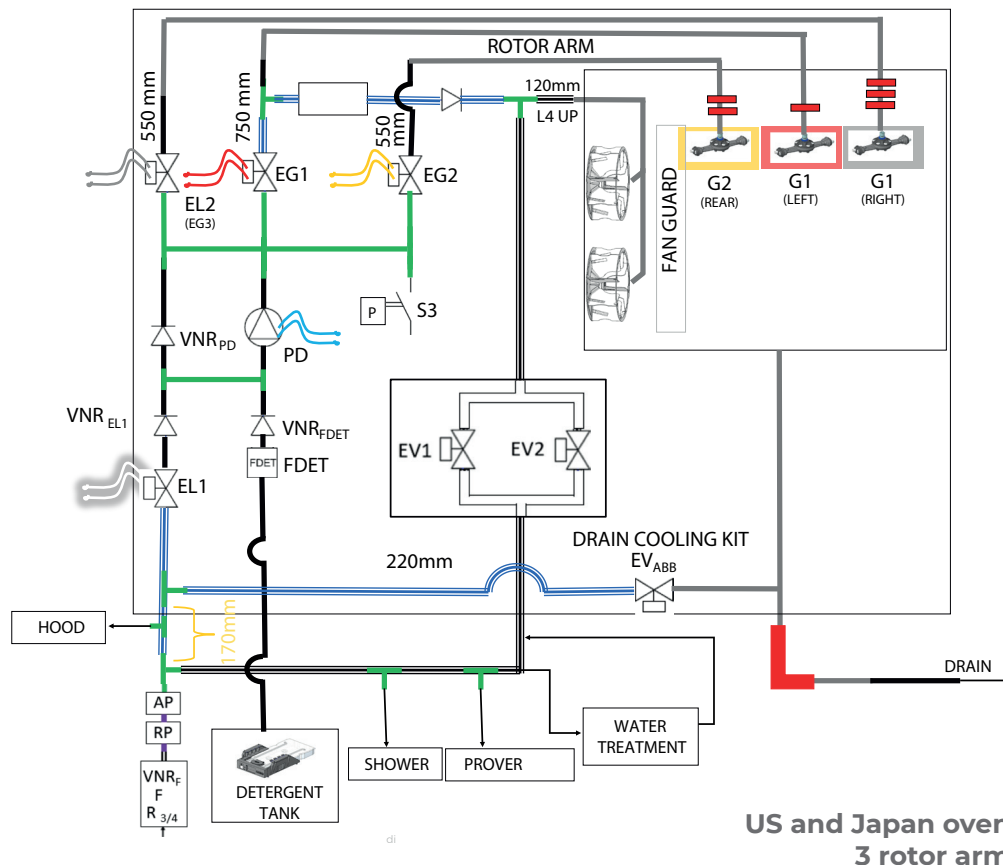
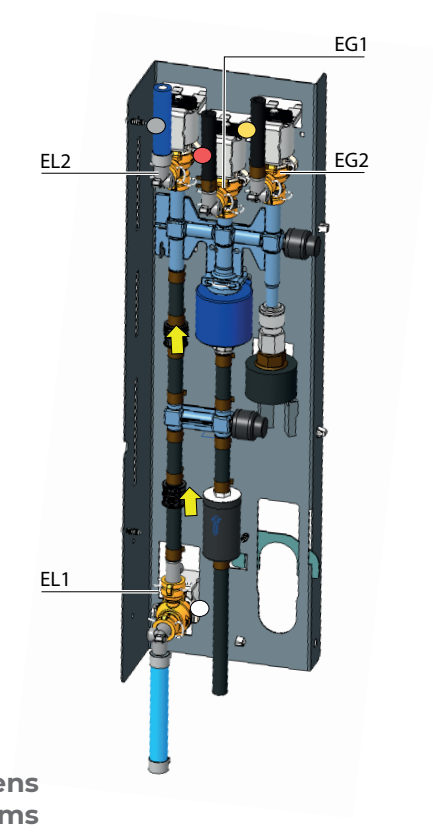
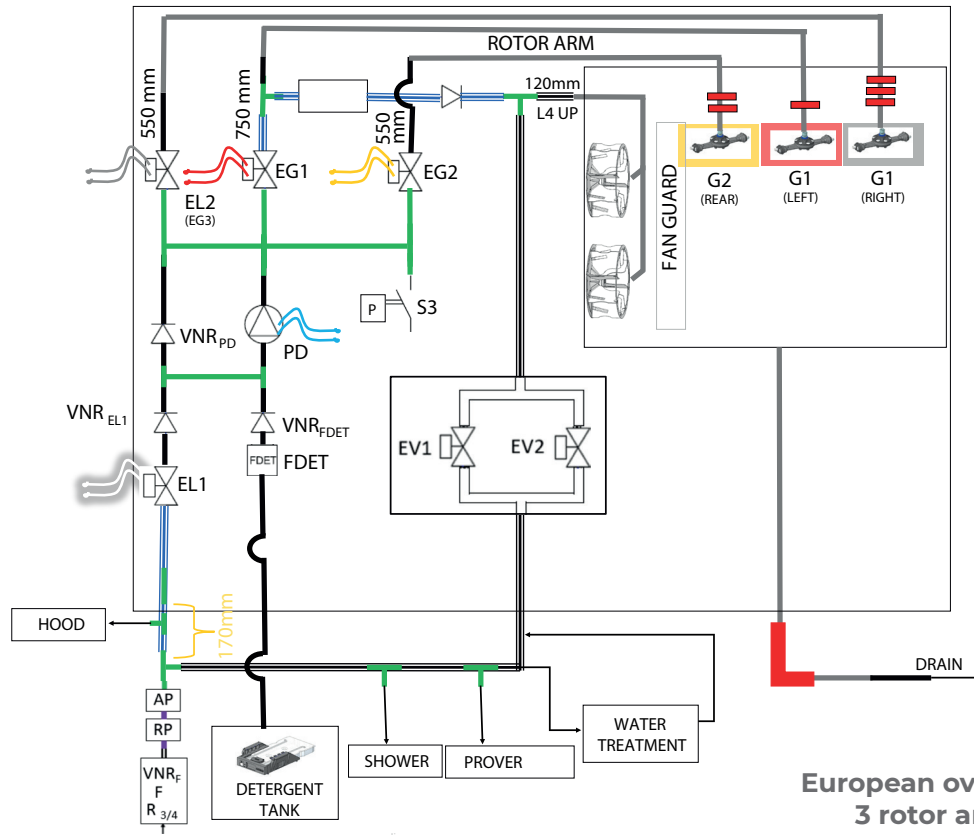
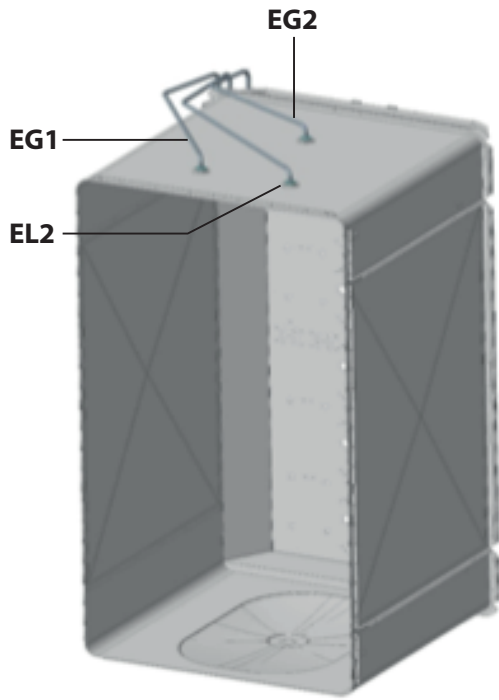
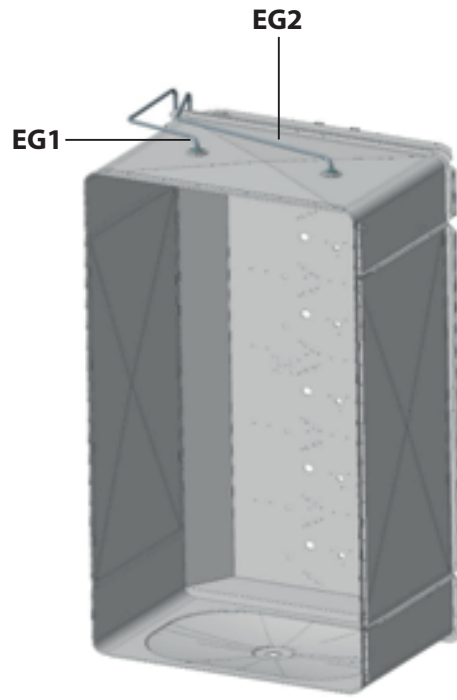

Figure 18

► The new rotor arm layouts



20 GN 2/1 10 GN 2/1
16 FS 06 GN 2/1



20 GN 1/1
16 EU 600x400

Figure 19

► Washing Cycles

The washing steps differ from model to model and from one washing program to another.

All the long programs follow the same steps.

Below shows the long washing program for 2 rotor arms for Plus models. This is similar to all models and washing programs.

The Long washing program with 2 rotor arms following the below steps;

1) Prediagnostic: The washing valves are opened and closed multiple times in order to unblock them from the possible presence of dirty or limescale.

2) Diagnostic: The opening and closing of the washing valves are checked with the pressure switch and if the pressure switch doesn't measure the desired value, a warning pops up in the control panel.

3) A

4) A* opposite sense of rotation

5) C

6) Final Rinse

7) Drying

Table 21

Long washing program for 2 rotor arms for Plus models

	A	A*	C
1	#1 Activating EG1 + Det Pump	Residual Detergent Rinsing	#1 Activating EG1 + DET Pump
2	#1 Activating EG2 + Det Pump	Short standby for Chemical reaction of the Detergent to remove dirt	#1 Activating EG2 + DET Pump
3	#1 Activating EL2 + Det Pump	EV1-EV2 Rinse	#1 Activating EL2 + DET Pump
4	Standby for chemical reaction of the Detergent to remove dirt	EG2 Rinse	Standby for chemical reaction of the Detergent to remove dirt
5	#2 Activating EG2 + Det Pump	EL2 Rinse	Steaming
6			#2 Activating EG1 + DET Pump
7			#2 Activating EG2 + DET Pump
8			#2 Activating EL2 + DET Pump
9			Standby for chemical reaction of the Detergent to remove dirt
10			Steaming
11			Residual Detergent Rinsing
12			Short standby for Chemical reaction of the Detergent to remove dirt
13			EV1-EV2 Rinse
14			EG2 Rinse
15			EL2 Rinse
16			EG1 Rinse

CHEFTOP MIND.Map^s™ BIG

The new floor-standing trolley ovens have been launched in April 2019 named as CHEFTOP MIND.Map^s™ BIG PLUS. Built on the current MIND.Map^s™ line the ovens have improved drastically in terms of design, durability, and performance. This chapter is going to give details on the improvements and modifications. The points that aren't mentioned should be considered as the same as the MIND.Map^s™.

CHEFTOP MIND.Map^s™ BIG ovens range has the following number and size of trays. For gastronomy ovens 20 trays GN 1/1, 20 trays GN 2/1 and 16 trays FS. For bakery ovens 16 trays 600x400 and 16 trays FS for Latin America. The power of the current electric oven range is between 29.3 to 51,3 kW. The US version has a power between 36 to 54,5 kW depending on the voltage of the power supply. The gas power of the current gas oven range is between 34 to 68 kW. The US version has a power of 70 kW. The codification language of the new CHEFTOP MIND.Map^s™ BIG trolley ovens have been designed to provide immediate information about the technical characteristics of the new models. The new ovens use an "L" instead of the current "C" as the 4th letter of the code.

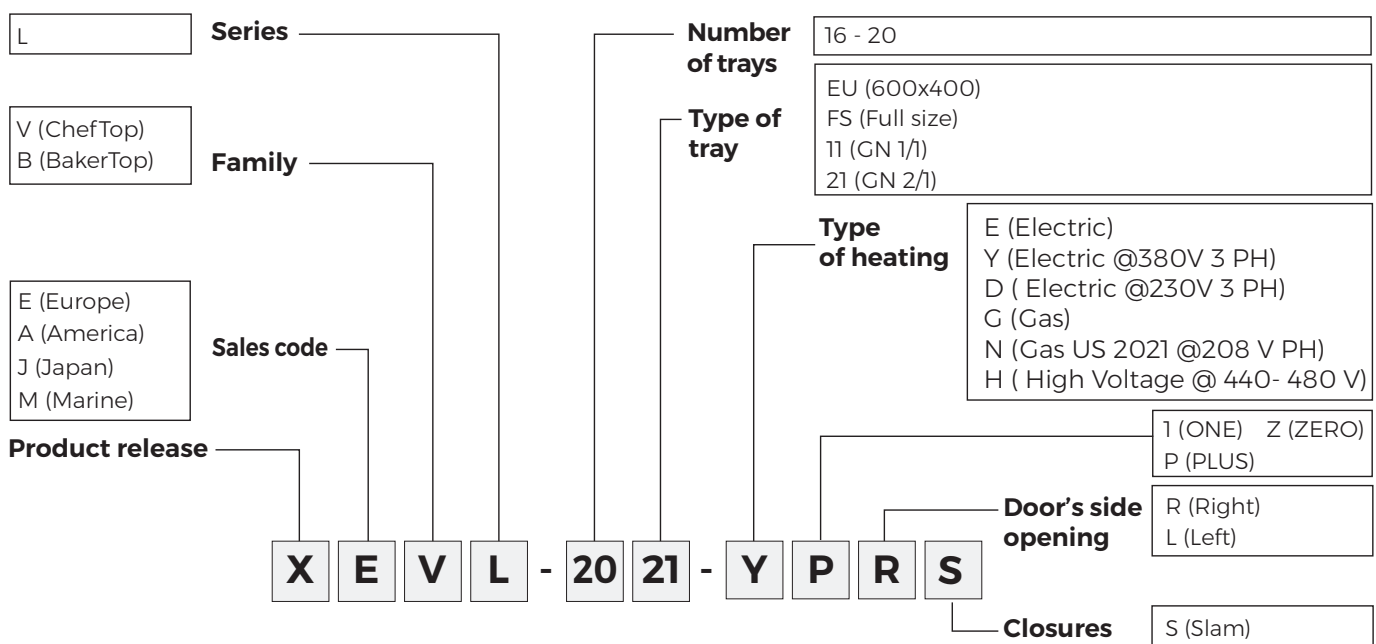

Customization:

- FO (Fornetti)
- VM (Vandemoortele)
- AL (America Latina)
- AS (Australia)
- GB (Great Britain)
- ID (Indonesia)
- KR (Korea)
- TW (Taiwan)

i.e.: **XEVL-2021-YPRS.0**

New letter L as the 4th letter for the new range

New letter S as the 8th letter for the push to close system

New digit for identifying the power supply for the electric oven:

Y stands for 380-415 VAC 3 phases and neutral (star connection)

D stands for 220-240 VAC 3 phases with no neutral (delta connection)

E remains for ONE ovens

The last digit of the code is a deep internal revision, but it's an integral part of the code

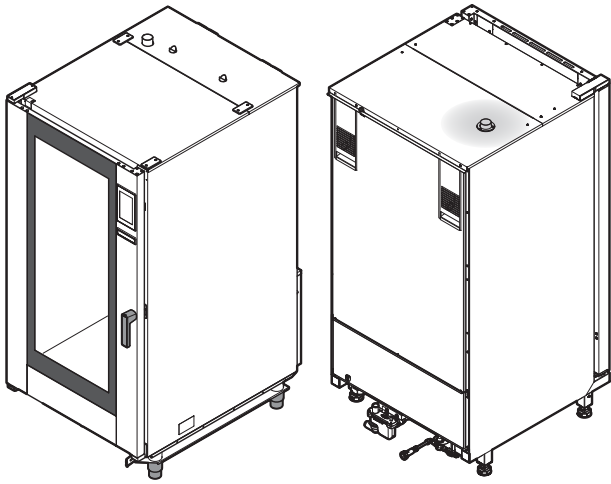

Figure 20

► External Case

The top panel is divided into two parts both for electric ovens and for gas ovens. The panel that is close to the back plate to get access to the heat exchanger and the panel that is close to the door to reach the ROTOR.Klean system.

The back panel is divided into two flat parts, with no protrusions. No need to remove U-trap to open the back panel. The gas throttle is accessible by removing the lower part of the back panel.

► Cooking chambers

Chamber A is designed to ensure the optimal cooking performance for GN 2/1 and 16 FS and is equipped with three washing arms, while the washing arms position has been changed for chamber B.

Chamber B has been developed to ensure the optimal cooking performance for GN 1/1 and 16 EU.

The bottom and side metal sheets of the cooking chamber are press punched in order to increase the stiffness and to avoid any type of deformation. The sheet thickness is 10/10 mm and is made of AISI 316L, as with all the other parts that might be in contact with the food (trolley too). All the parts are completely welded.

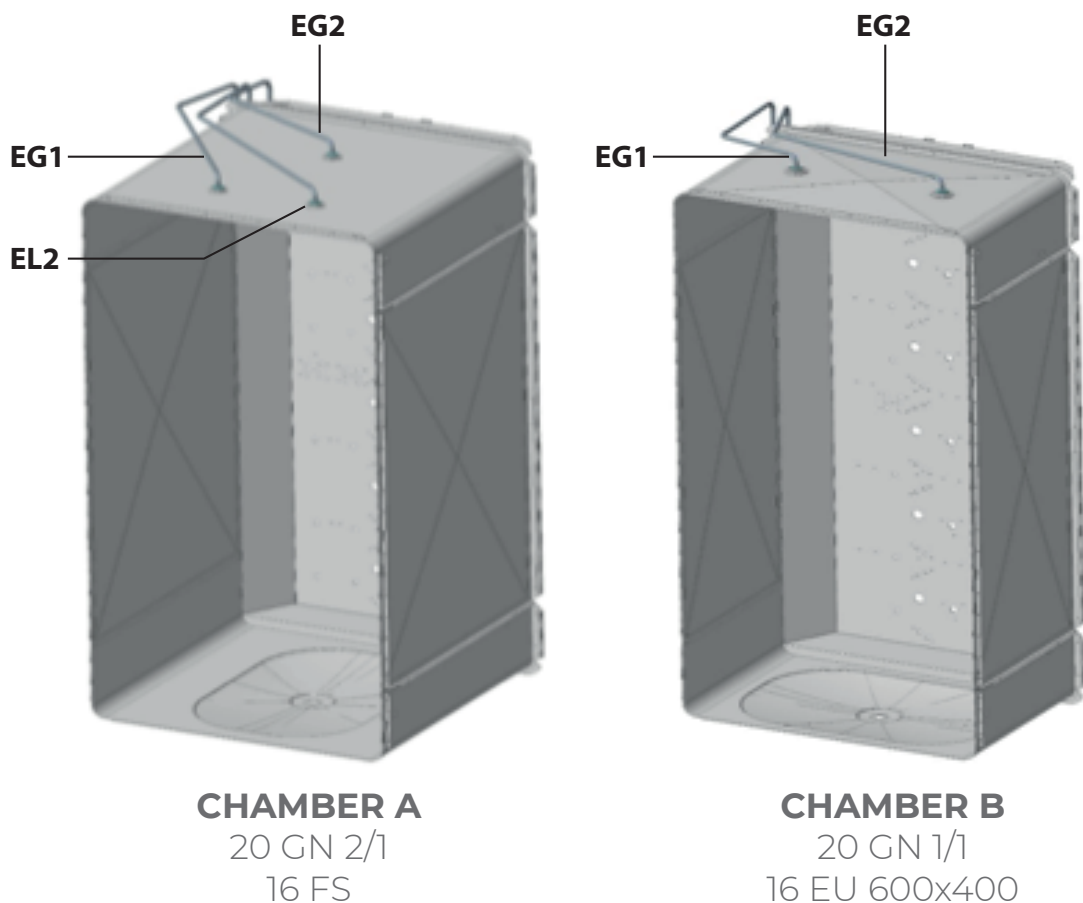

Figure 21

► Electric System

New CHEFTOP MIND.Maps™ BIG has of 6 motors in PLUS ovens. This improvement involves an increase in the absorbed power that the single power board is not able to manage. In order not to overload the stages of reverse rotation, it is necessary to adopt an additional motor power board to divide the absorbed load.

- The safety thermostat that protects the motors from overheating will act on all the motors at the same time and will stop the heating in the cooking chamber,
- The actual rotation of the two motors out of the six motors is constantly measured and monitored. The engine revolution sensors are placed on the top and bottom engine.

Note: The second powerboard is needed because the single power board is designed to power up to 5 motors. Do not bridge all the motors with one power board.

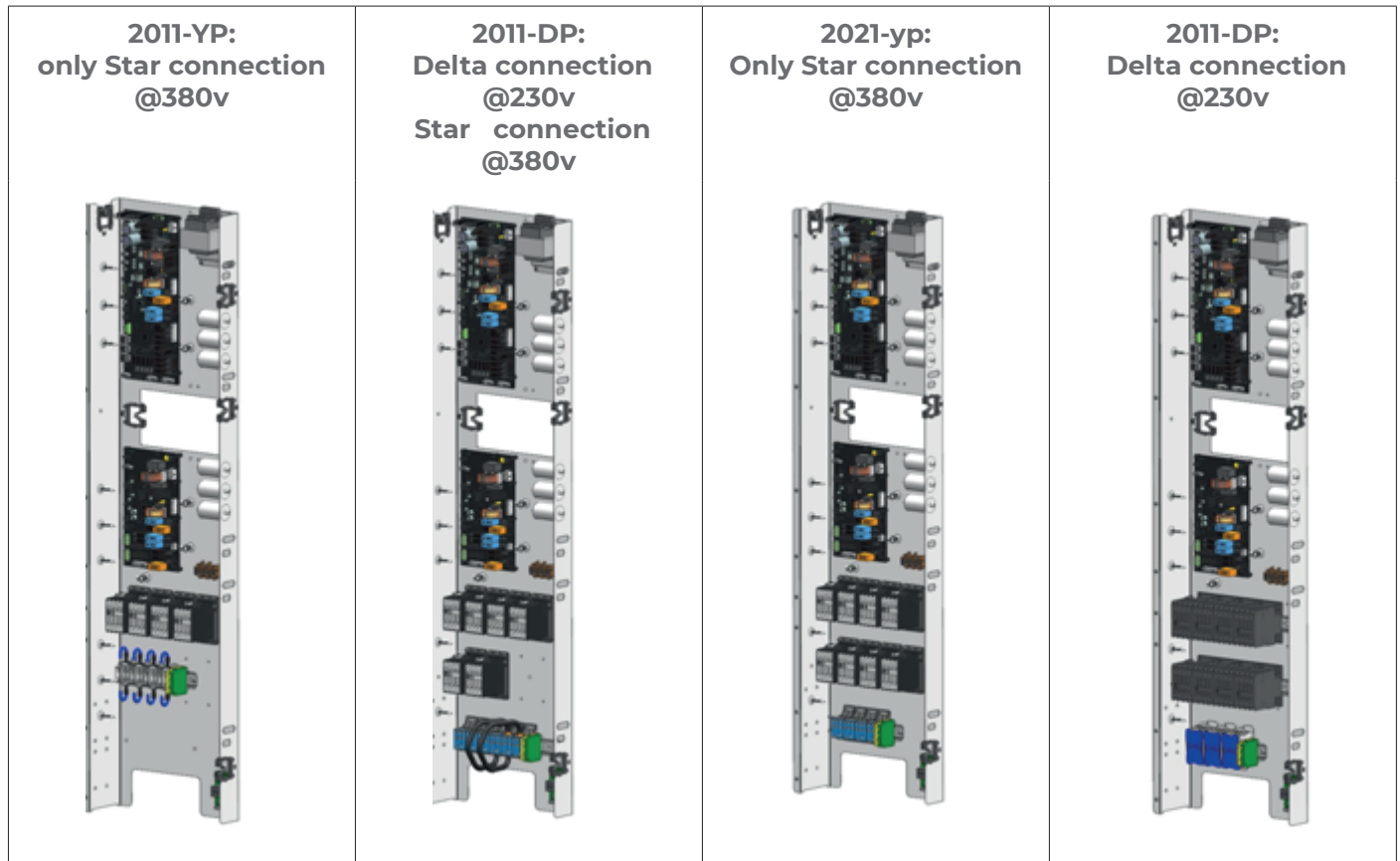

Figure 22

► Power boards

The primary power boards that are used are the same in CHEFTOP MIND.Maps™ BIG and the same as MIND.Maps™ countertop or trolley ovens. For the electric CHEFTOP MIND.Maps™ BIG Plus, the power board is [KPE2038A](#) for European ovens and for the gas oven, it is KPE2021C.

What differentiates at the CHEFTOP MIND.Maps™ BIG from its predecessor is the additional auxiliary power board (KPE2143A). The new power board manages three motors, the new PT1000 core probe, and the second revolution sensor. More details can be found on the earlier Power boards section number 2 with the explanation of each and every socket in the auxiliary board.

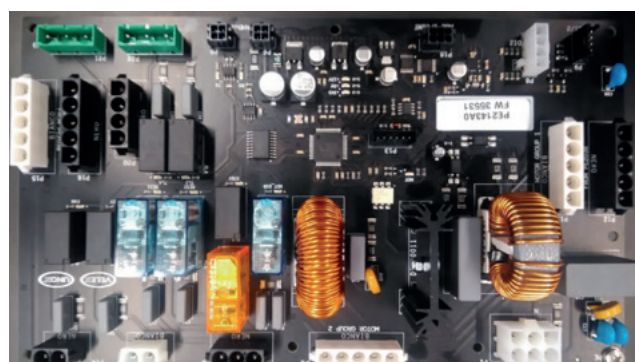
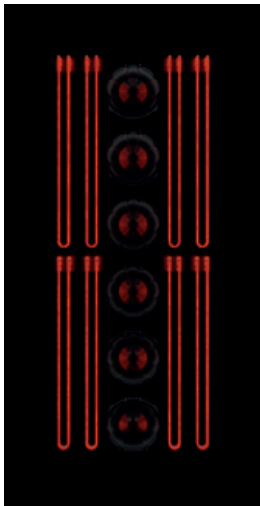

Figure 23



► Heating Element

- New heating elements design:
 - Configuration for GN 1/1 - 16 EU4 x 6625 W linear heating element
 - Configuration for GN 2/1 - 16 FS 4 x 9000 W linear heating element
- 2 braking elements per motor, 100 W and 147 W



► SPIDO.Gas™ system

- New spiral baffle design
- Heat exchangers thickness increased from 15/10 mm to 20/10 mm
- Every BIG gas oven has two blowers,

The gas supply for GN2021 and 16FS is increased from $\frac{3}{4}$ " to 1" while GN2011 and 16EU remain same as $\frac{3}{4}$ ".

16EU & 2011	2021
$\frac{3}{4}$ "	1"

► Six motors for PLUS range

- An extra motor-fan group has been introduced on plus ovens,
- Same asynchronous single-phase motor and same 8-blade fan group,
- Fan guard thickness has increased from 10/10 to 12/10 mm in AISI 316L

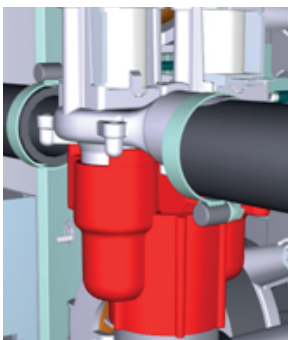

Solenoid Actuator

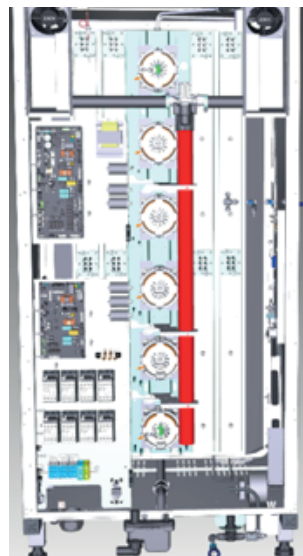

Single collector pipe 50 mm

► DRY.Maxi™ system

The diameter of the venturi pipes from the motor increased from 16 mm to 20 mm, and with a single collector, the pipe is 50 mm in diameter. Besides the extraction pipe, there are two solenoid actuators with, each valve is connected to a cooling fan. Humidity extraction speed increase by 88% and reduced the time required to remove the humidity by 50%

Figure 24

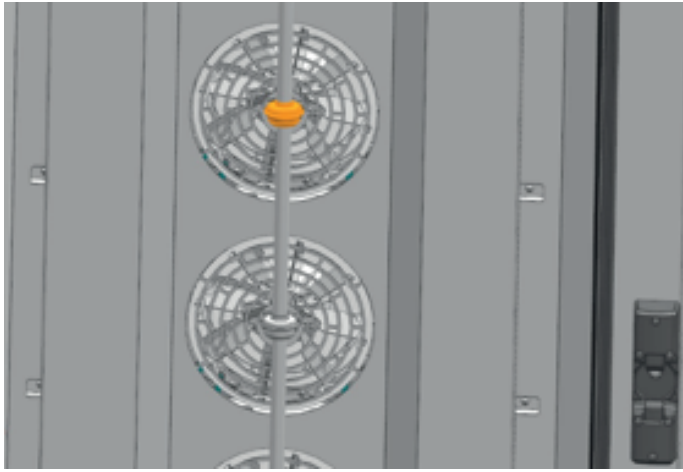

► Steam.Maxi™ system

The sole improvement made regarding the Steam.Maxi™ is that the steam distributor is made of steel instead of plastic. The remaining mechanism and systems are the same as MIND.Maps™ counter top models.

Figure 25

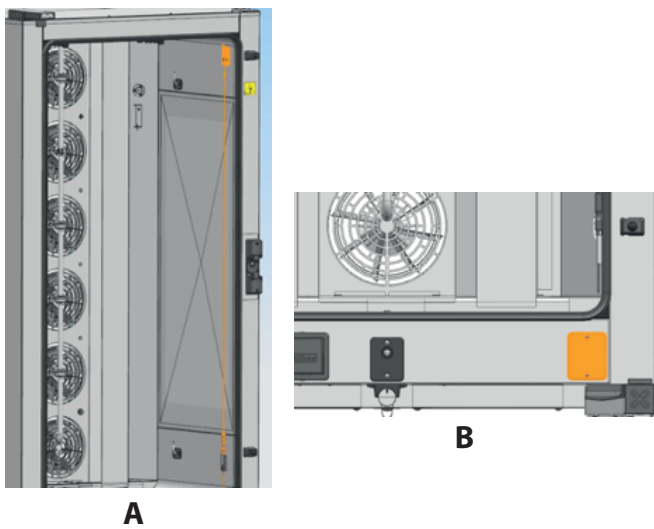

► Core probe

The core probe used is a PT1000. The values are 10 times more accurate compared to PT100. The core probe gets into the cavity from the top right side is held in place by a plate. The probe is connected to the bridgeboard that is located on the bottom right corner of the oven to simplify the maintenance and replacement of the core probe. The new core probe board is PE2142A0 and is connected via a special CANBUS cable (CE1975A0) to the auxiliary power board. PT1000 type probe SN1049A0 metallic mesh plus 5 tape layers and the tip is extended by 1 cm.

Figure 26

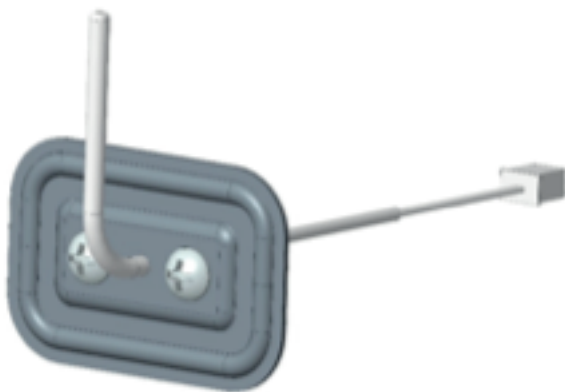

Figure 27

► Temperature probe

The cooking chamber temperature probes have been improved to increase the reading accuracy of the temperature in the cavity.

The following changes have been introduced:

- New hook design, with its tip extended by 1 cm compared with the previous generation,
- Mineral oxide insulation for the top temperature probe. This probe can be used to check the proper measurement of the bottom probe and can replace the lower one in case of malfunction,
- The ratio between length and diameter has been improved (10/1)

Top temperature probe;

- acts as the back-up probe
- checks the overheating of the ceiling

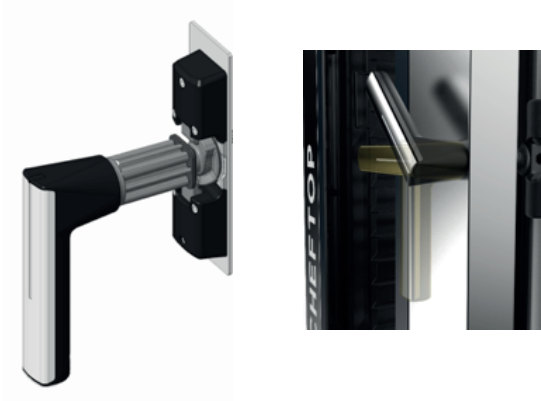

Figure 28

► Push-to-close door with Switch

The Door handle and door microswitch are merged into one component with the new MIND.Maps™. The latch incorporates the switch and the door pin has a stainless steel central shaft. The central pin has been designed in stainless steel to ensure minimum friction and maximum strength.



Figure 29

► Safety thermostat

The new MIND.Maps™ has a new design and new safety thermostat as the oven can reach up to 300°C (572°F). The safety thermostat has a trigger limit of 350 °C (662°F).

The new safety thermostat accurately reads the temperature thanks to its design. The pin is held by a bracket so that the thermostat is not in contact with the cavity. This guarantees a perfect temperature reading.



Figure 30

► Centrifugal Fan

A motor is positioned in the bottom right corner of the oven to cool down the external part of the oven. The cold air circulates in-between the external case and the cooking chamber.

It only activates when the oven reaches over 180°C (356°F).

CHEFTOP MIND.Maps™ ZERO

The new convection ovens are launched in February 2020 and called CHEFTOP MIND.Maps™ ZERO. Built on the current MIND.Maps™ line, the ovens have improved drastically in terms of esthetic, design, and performance. The chapter below details the improvements and changes made. Zero ovens are designed with the Mind.Maps™ family. Zero ovens are equipped to provide steam, but automatic cleaning cannot be performed because they don't have washing circuits.

CHEFTOP MIND.Maps™ ZERO ovens range come in the 5,7 and 10 trays models with GN 1/1 standard. The codification language of the new CHEFTOP MIND.Maps™ ZERO ovens have been designed to provide immediate information about the technical characteristics of the new models. The new ovens use a "Z" that represents zero, "1" for "ONE" models and "P" for plus models.

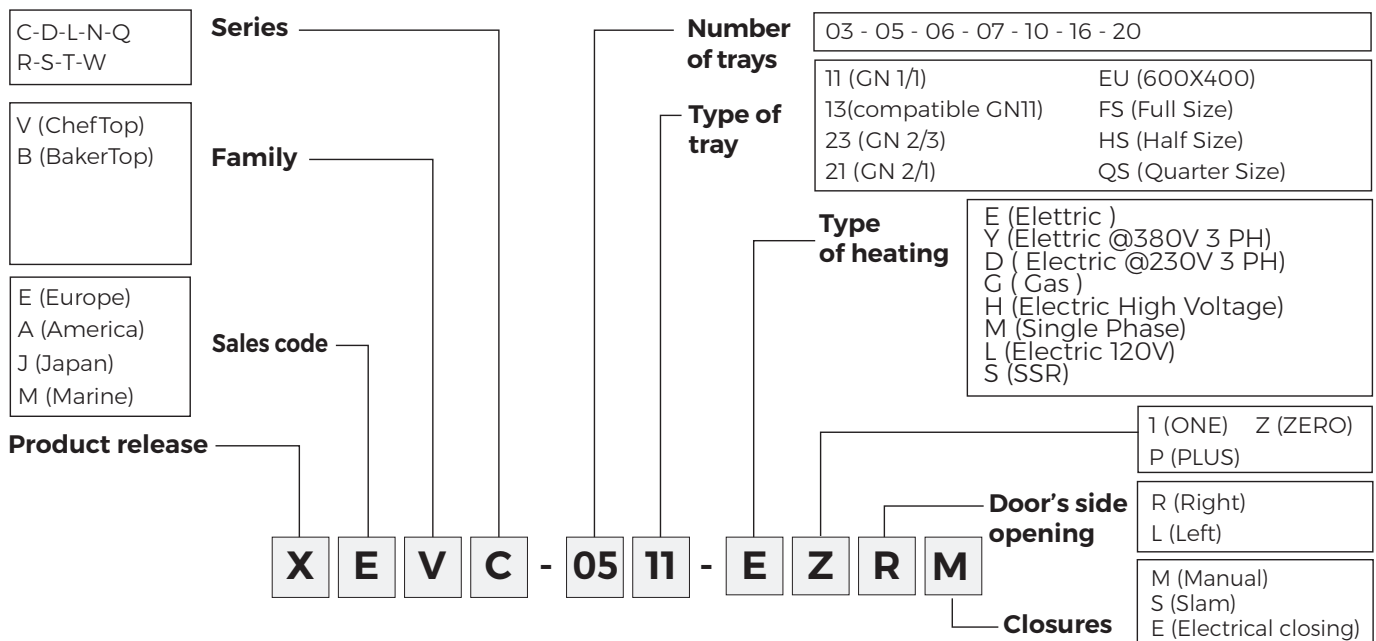

i.e.: **XEVC-0511-EZRM.0**

CHEFTOP MIND.Maps™ ZERO can be considered as an entry-level model to budget the combi segment as it doesn't have any of the cooking technologies such as ADAPTIVE.Cooking™, SENSE.Klean as opposed to ONE and PLUS models. CHEFTOP MIND.Maps™ ZERO can also not be connected to the internet. See the table below.

UNOX INTELLIGENT PERFORMANCE	
ADAPTIVE.Cooking™: automatically regulates the cooking parameters to ensure repeatable results	-
CLIMALUX™: total control of the humidity in the cooking chamber	-
SMART.Preheating: sets the temperature and the preheating duration automatically	-
AUTO.Soft: manages the heat rise to make it more delicate	-
SENSE.Klean: estimates how dirty the oven is and suggests appropriate automatic cleaning	-
UNOX INTENSIVE COOKING	
DRY.Plus™: extracts humidity from the cooking chamber	●
STEAM.Plus™: creates instant humidity starting from 90 °C	●
AIR.Plus™: multiple fans with reverse gear and 2 speed settings	●
EFFICIENT.Power: ENERGY STAR certified energy efficiency	-
DATA DRIVEN COOKING	-
Wi-Fi connection	-
Ethernet connection	-
ddc.unox.com: control the oven usage in real time and create and send recipes from your PC to your ovens	
DDC.Stats: analyse, compare and improve the user and consumption data of your oven	-
DDC.App: monitor all connected ovens in real time from your smartphone	-
DDC.Coach: analyses the way in which you use the oven and suggests personalised recipes	-
MANUAL COOKING	-
Convection cooking from 30 °C to 260 °C	●
Convection + humidity cooking starting from 90 °C	●
Saturated steam cooking starting from 90 °C	●
Convection cooking + forced humidity extraction from 30 °C	●
Cooking with core probe and DELTA T function	-
Single-point core probe	-
MULTI.Point core probe	-
SOUS-VIDE core probe	-
ADVANCED AND AUTOMATIC COOKING	
MIND.Maps™: draw the cooking processes directly on the display	-
PROGRAMS: up to 384 programmes that can be saved with name, picture or handwritten signature	-
CHEFUNOX: choose something to cook from the library and the oven will automatically set all the parameters	-
MULTI.Time: manages up to 10 cooking processes at the same time	-
MISE.EN.PLACE: synchronises the insertion of pans so that all the dishes are ready at the same time	-
3 cooking steps	●
12 quick programs	●
Store up to 99 programs	●
AUTOMATIC CLEANING	-
Rotor.KLEAN™: 4 automatic cleaning programmes	-
Rotor.KLEAN™: water and detergent level detector	-
Integrated DET&Rinse™ detergent container	-

TECHNICAL DETAILS	
Cooking chamber in high-resistance AISI 304 stainless steel with rounded edges	●
Cooking chamber with C-shaped rack rails	●
Cooking chamber lighting through LED lights embedded in the door	●
	●
Drip collection system integrated in the door and functional even with the door open	●
Heavy-duty structure with the use of innovative materials	●
2-speed fan system and high-performance braking resistance	●
Door hinges made of high-resistance, self-lubricating techno-polymer	●
Door stop positions 60° - 120° - 180°	●
Carbon fibre door pin	○
Reversible door in use even after installation	●
70mm door thickness	○
Detachable internal glass door for ease of cleaning	●
Two-stage safety door opening / closing	●
Proximity door contact switch	●
Self-diagnosis system to detect problems or breakdowns	-
Temperature safety switch	-

- Standard
- Optional
- Not available

To better understand the difference between the PLUS, ONE and ZERO please the comparison below.

PLUS

9.5" touchscreen capacitive control panel

COMBI STEAMER

ONE

7" touchscreen resistive control panel

COMBI STEAMER

ZERO

7 segments display LED
CONVECTION OVEN + HUMIDITY

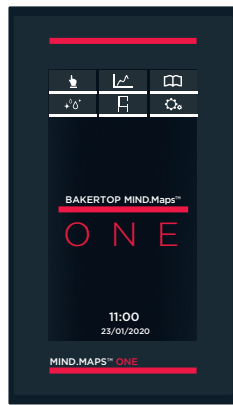
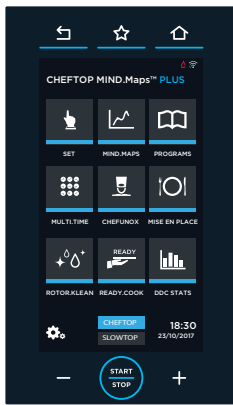
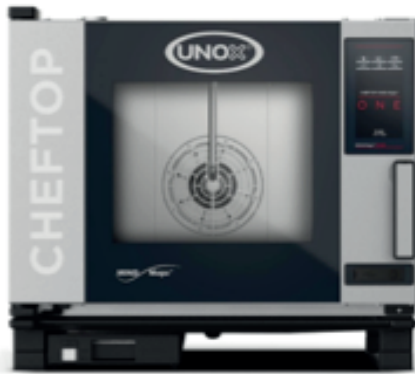

The heating system power of all three models is the same. This means that in terms of rising temperature all models are performing the same.

Armed carbographe gasket

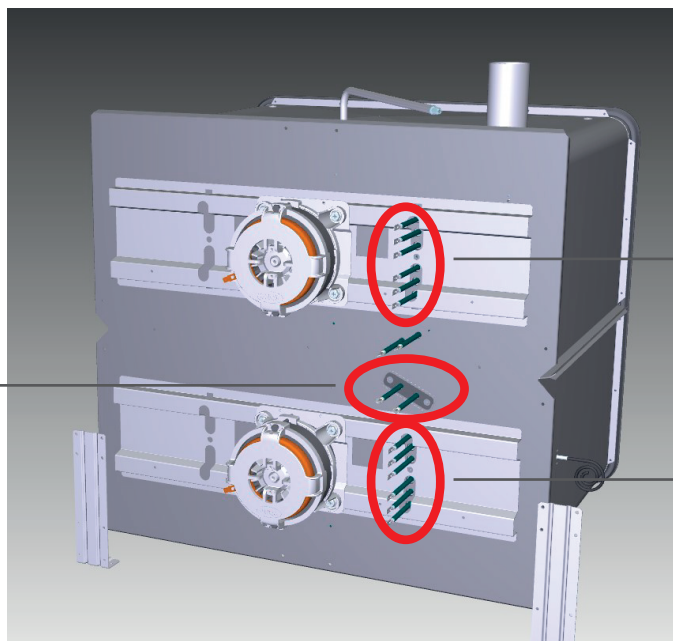

Same heating element in ONE, PLUS, ZERO GN 1/1

Same heating element in ONE, PLUS, ZERO GN 1/1

SERVICE MENU

The hidden menu can be accessed with the oven in stand by mode by pressing buttons P4 - P4 - P5 - P6. The buttons must be pressed with a maximum of 1 between each press.

Once you are inside the hidden menu, use the PRE, STEP1 and STEP2 buttons to move through the 3 modes:

- PRE: sets the address of the board to display/modify the parameters. Address 1 = power board, 10 = control board
- STEP1: show the name of the active parameter
- STEP2: show and can modify the value of the active parameter

After changing the value of a parameter, press the 7-segment displays for a few seconds, until a confirmation beep, to save the change.

Parameter list:

DEG

the step temperatures are in degrees Fahrenheit

the step temperatures are in degrees Celsius

PRG

the oven only works by starting saved programs, you cannot modify the program

the oven also works with manual programs

LOC

saved programs are not editable

the programs are editable

MAS

Maximum temperature in °C that can be set in the oven

STB

Minutes of inactivity before the oven goes into standby

FOB

Buzzer frequency

MWL

Manually increase or decrease the water supply (from -2 to +1, each position modifies it by 20%)

TMP

If different from zero, it's the temperature in °C that the oven maintains (with infinite time) at the end of each program started. In addition, the oven starts with infinite time at the TMP temperature even if you press START without having set a program.

TMF

Like the TMP parameter but the TMF temperature is in fahrenheit. TMF only works if TMP is equal to zero.

PAS

Starts a quick program (P1 - P11) as soon as the corresponding P is pressed. Without pressing START with, Traditional program start.

POC

Oven chamber temperature preset at ignition in °C (use only if the oven is set in Celsius)

POF

Oven chamber temperature preset at ignition in °F (use only if the oven is set in Fahrenheit)

SPE

The ZERO oven has 2 speeds available (normal and slow)

The ZERO oven only works with normal speed

BZP

If the value is "-1" the buzzer doesn't beep. The buzzer at the end of preheating sounds until the door is open (available values are from 0 to 999). The buzzer at the end of preheating sounds for the seconds indicated by the parameter (minimum 1 second).

BZC

If the value is "-1" the buzzer doesn't beep. The buzzer sounds at the end of the cooking cycle (available values are from 0 to 999). The buzzer at the end of cooking sounds for the seconds indicated by the parameter (minimum 1 second).

RES

(1)The heating elements of the oven are always on

(0)The heating elements of the oven are always off (expo mode)

OFI

Offset in ° C to be added to the measured value of the oven temperature probe

TFN

activation temperature in ° C of the cooling fan

Fault message guides for Zero range

*Please note that the alarms not mentioned below are the same as BAKERLUX SHOP.Pro™ range.

INDEX

AF03 - Temperature probe damage alarm	95
AF04 - Communication error with power board.....	96
WF06/U01 – Power board over heating warning.....	97
WF33 – SD card corrupted.....	98

AF03 – DAMAGED TEMPERATURE PROBE ALARM

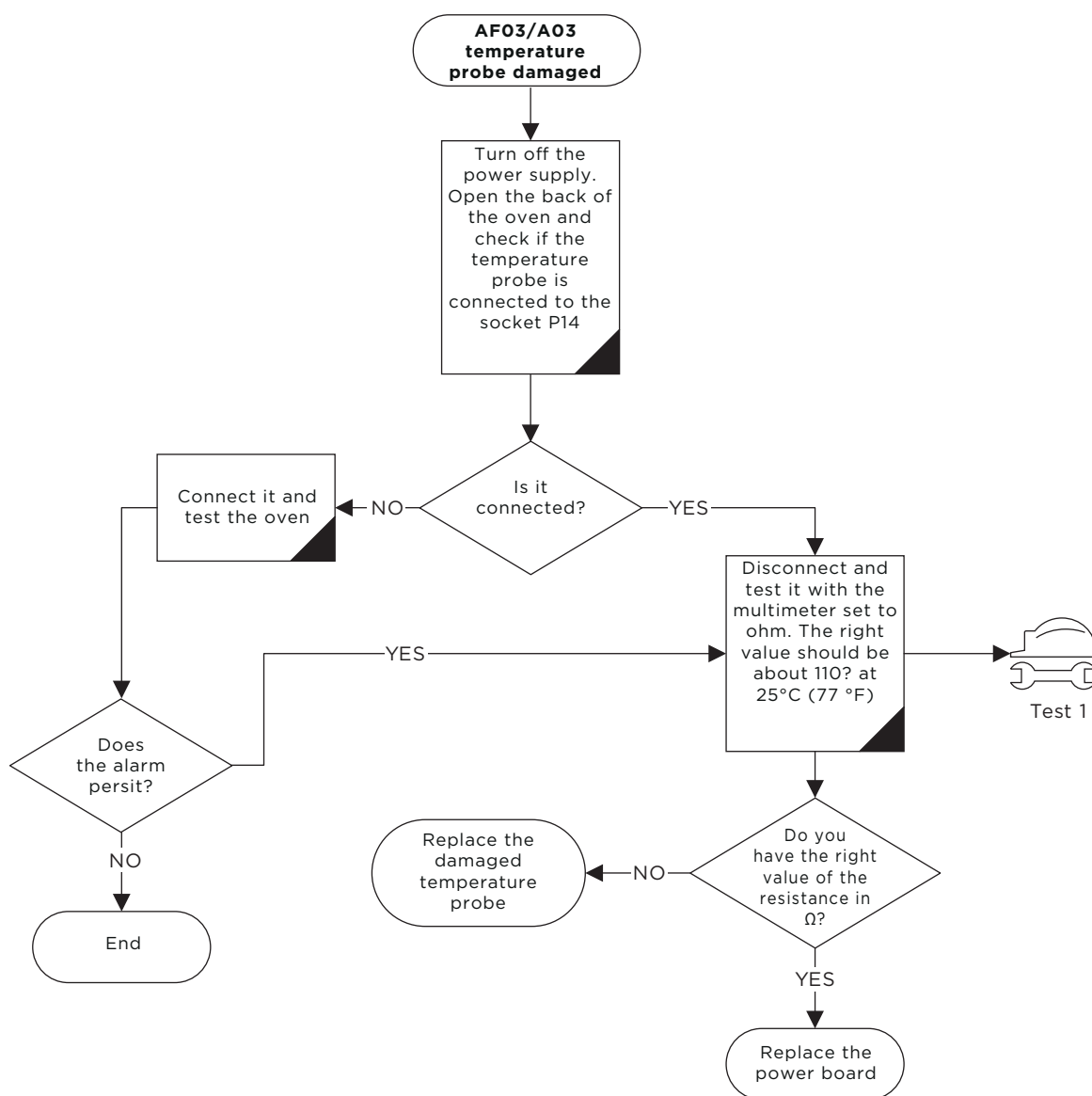

AF04 – POWER BOARD COMMUNICATION ERROR

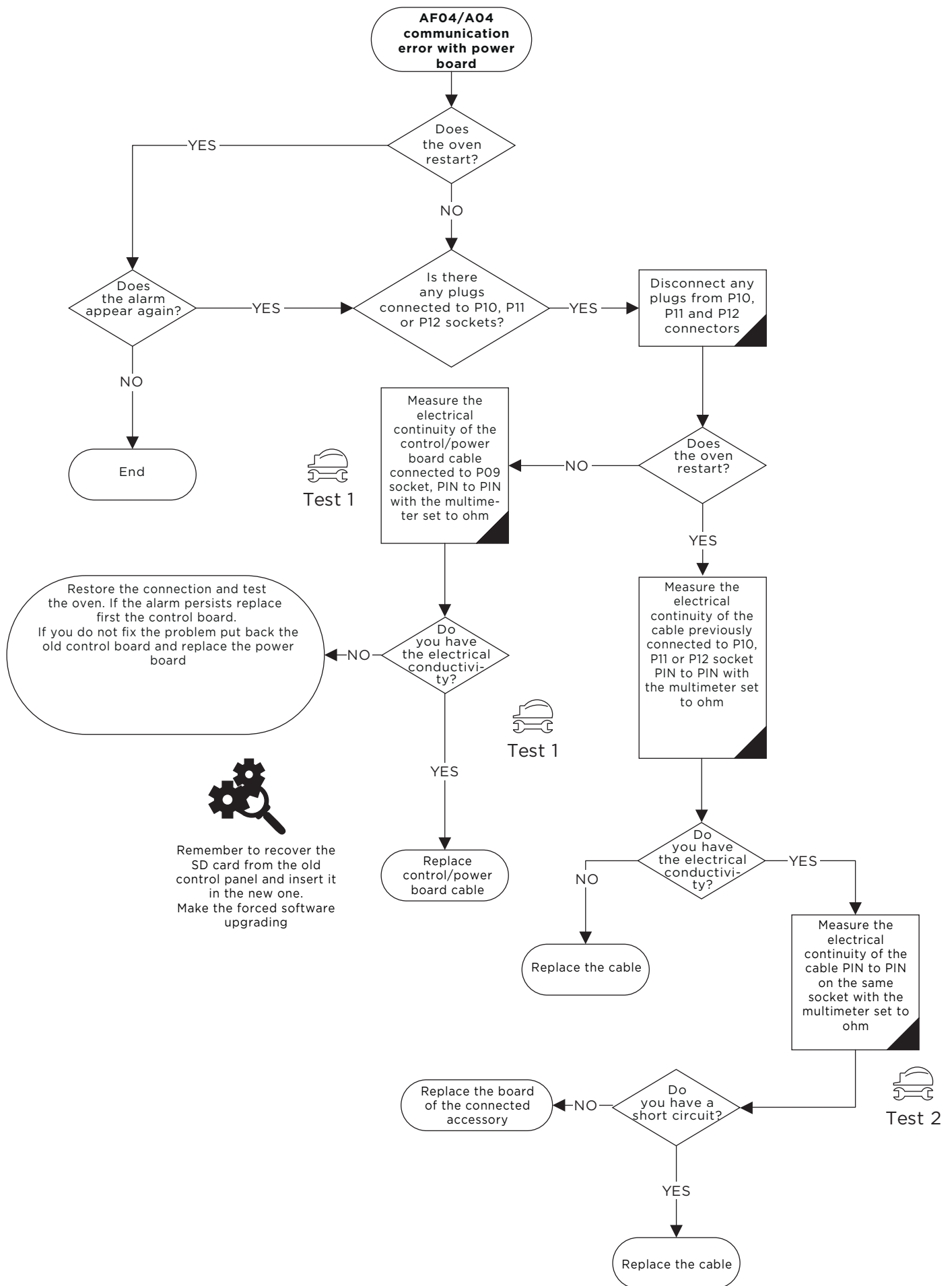

WF06/U01 – OVERHEATING POWER BOARD WARNING

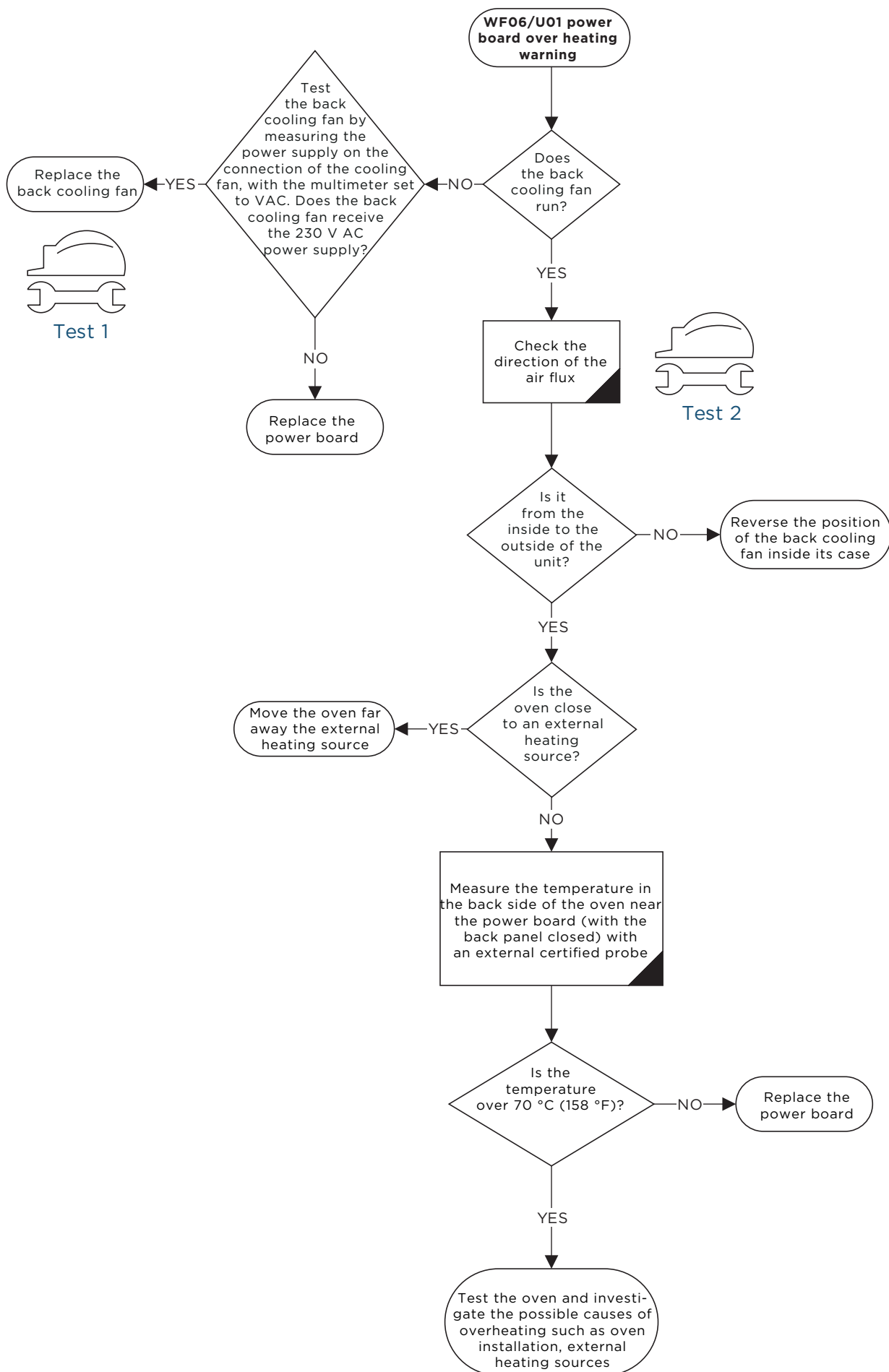

WF33 – CORRUPTED SD CARD

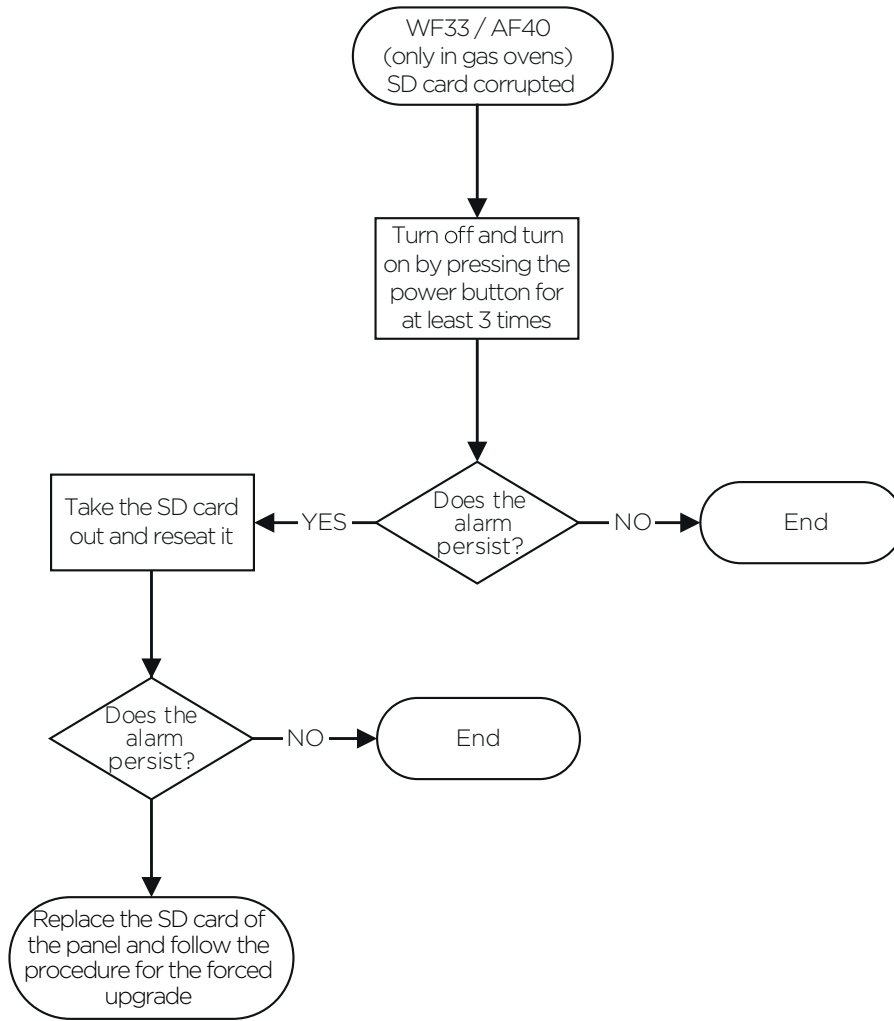

PROBLEM SOLVING GUIDE

Check the following point if:

Symptom	Problem	Solution
The oven does not turn on	F1 fuse of the power board blown	Replace the fuse, 160 mA Fast acting. If the problem persists replace the power board
The oven does not turn on	F2 fuse of the power board blown	Disconnect the low voltage loads sockets: P9, P10, P11, P12, P13 and P14 and replace the fuse (2A – 250 V Time Delay), connect the above sockets one by one until you find the shorted component, therefore replace it. If the fuse continues to blow replace the power board
The oven does not turn on	Power board damaged	Measure on P9 socket between the blue and brown wires with the voltage with the multimeter set to VAC. If the power board does not supply 12 VDC to the control panel replace the power board.
The ground fault circuit interrupter (GFCI) triggered	When you turn on the power supply the GFCI triggers immediately	The transformer has an electrical leakage, therefore replace the power board.
The ground fault circuit interrupter (GFCI) triggered	When the control board reboot the GFCI triggers	The back-cooling fan supplied at 230 V AC has an electrical leakage, therefore replace the back-cooling fan
The ground fault circuit interrupter (GFCI) triggered	When the oven is running a cooking program the GFCI triggers	<p>Proceed as follow:</p> <p>Set a cooking program, t = inf, T = 30 °C, v = 2 and run the oven.</p> <ul style="list-style-type: none"> • If the GFCI triggers, it means that at least one motor has an electrical leakage. Test between the black and red wire of the motor socket and the body of the oven with the multimeter set to ohm. If there is a ground fault, replace the damaged motor. <p>If the GFCI does not trigger set T = 260 °C and run the oven.</p> <ul style="list-style-type: none"> • If the GFCI triggers it means that at least one heating element has an electrical leakage. Test between the cable harnesses of each heating element connector and ground with the insulation resistance tester, if there is a ground fault, replace the damaged heating element; <p>If you run the oven at T = 260 °C GFCI does not trigger, set STEAM.Plus to 100 % and run the oven.</p> <ul style="list-style-type: none"> • If the GFCI triggers, it means that the steam solenoid valve has an electrical leakage. Test between the cable harnesses of the solenoid valve and ground with the multimeter set to ohm. If there is a ground fault, replace the damaged solenoid valve.
The circuit breaker triggered	When the control board reboots the circuit breaker triggers	The back-cooling fan supplied at 230 V AC is shorted. Replace back-cooling fan

Symptom	Problem	Solution
The circuit breaker triggered	When the oven is running a cooking program, the circuit breaker triggers	<p>Set a cooking program, $t = \text{inf}$, $T = 30\text{ }^{\circ}\text{C}$, $v = 2$ and run the oven.</p> <ul style="list-style-type: none"> If the circuit breaker triggers, it means that at least one motor is shorted. Test between the black and red wire of the motor socket. If there is electrical continuity with the multimeter set to ohms, replace the faulty motor. <p>If the circuit breaker does not trigger, set $T = 260\text{ }^{\circ}\text{C}$ and run the oven.</p> <ul style="list-style-type: none"> If the circuit breaker triggers it means that at least one heating element is shorted. Test between the cable harness of the heating element coils. If there is electrical continuity with the multimeter set to ohms, replace the damaged heating element. <p>If with $T = 260\text{ }^{\circ}\text{C}$ the circuit breaker does not trigger, set STEAM.Plus to 100 % and run the oven.</p> <ul style="list-style-type: none"> If the circuit breaker triggers, it means that the steam solenoid valve is shorted. Test between the cable harnesses of the solenoid valve. If there is electrical continuity with the multimeter set to ohm, replace the faulty solenoid valve.
The electrical oven does not heat	A phase is missing	Try to plug the oven to another socket and run the oven. If the oven works properly call an electrician, otherwise follow the next steps
The electrical oven does not heat	Either the heating elements or the contactors are damaged	<p>Measure the amp consumption of the oven with the clamp meter directly on the terminal block.</p> <ul style="list-style-type: none"> If the phase consumption does not match the technical data available on Infonet, check if the contactors close the circuit. If they do not close the circuit, check between A1 and A2 PIN with the multimeter set to V AC if the power board supplies 230 V AC to the contactor coil. If the power board does not feed the contactors replace it, otherwise replace the contactors; <p>Measure the amp consumption of each heating element turns. If you find 0 A in at least one coil replace the element</p>
The oven does not cook evenly	The gasket is damaged	Replace the gasket
The oven does not cook evenly	The chimney is clogged	Clean the chimney with a metal brush
The oven does not cook evenly	The motors do not invert the sense of rotation	<p>Measure the resistance of the braking element with the multimeter set to ohm. Do you have the right resistance value according to the technical data?</p> <ul style="list-style-type: none"> If not, replace the braking element If yes, replace the power board

Symptom	Problem	Solution
The oven does not cook evenly	The temperature probe is not calibrated	If you measure a difference lower or equal of 5 °C, between the real temperature of the cooking chamber and the temperature set, with a calibrated temperature probe placed close to the one of the oven, you can apply an OFFSET. See the section "BAKERLUX™ Service and User Menu" to see how to apply the offset. Therefore, if $T_{set} - T_{chamber} = +3.1$ °C (for instance $T_{set} = 180$ °C and $T_{chamber} = 176,9$ °C) you should set -31 in the probe offset to compensate. Thus 0.1 °C equals to 1 in scale of values.
The oven does not cook evenly	The temperature probe is damaged or the power board is defected	Measure the resistance of the probe circuit with the multimeter set to ohm. Do you have 110 Ω at 25 °C (77 °F)? <ul style="list-style-type: none"> · If not, replace the damaged temperature probe · If yes, replace the power board
The cooking chamber has spots and smears on stainless steel and glasses	The inflow water hardness is too high according to UNOX standart	If the inflow water quality is not in compliance with the technical data reported in the manual, install the proper water treatment system
The cooking cabinet has spots of rust on the stainless steel	The chloride content in the inflow water is too high according to UNOX standart	If the inflow water quality is not in compliance with the technical data reported in the manual, install a UNOX.Pure-RO. Polish the steel surface with a polish paste
The oven does not produce steam	The inflow water pressure is not enough	Measure the inflow water pressure with a pressure gauge. Do you have a value within the range $1.5 < p < 6$ bar? <ul style="list-style-type: none"> · If not, the water pressure is not in compliance with the UNOX specification · If yes, measure the pressure downstream at the output of the pressure reducer with a pressure gauge. Do you have a pressure equal to 2,3 bar? <ul style="list-style-type: none"> - If not, replace the pressure reducer - If yes, go on with the troubleshooting
The oven does not produce steam	The oven does not pump in water	Is the tap water open? <ul style="list-style-type: none"> · If not, open the tap water · If yes, do you have power supply to the steam solenoid measured with the multimeter set to V AC? <ul style="list-style-type: none"> - If not, replace the power board - If yes, is the steam pipe clogged? <ul style="list-style-type: none"> · If yes, clean the pipe and check the water quality · If not, replace the steam solenoid
The control panel is blank	The oven is in stand-by mode	When the oven is not running, every 15 minutes it goes into stand-by mode: the control panel is blank while the LED bar is turned on. To wake-up the oven touch the control panel screen except on the physical button. If for any reason the display does not turn on, press the power button to reboot the oven manually

Symptom	Problem	Solution
The control panel is blank	The control panel is not powered or damaged / the USB board is damaged	<p>Remove the control panel and measure between the black and yellow PIN of the main connector with the multimeter set to V DC. Do you have 12 V DC?</p> <ul style="list-style-type: none"> · If yes, replace the control board · If not, open the back of the oven and measure the voltage between black and yellow wires of the P09 socket with the multimeter set to V DC. Do you have 12 V DC? <p>- If yes, replace the control-power board cable harness - If not, verify the F2 fuse. Is it fine?</p> <ul style="list-style-type: none"> · If yes, replace the power board · If not, replace first the fuse that maybe is defected and then the power board
The control panel is completely white	The LCD screen is damaged	Replace the control panel
The brightness of the control panel is very low	The LCD screen is damaged	Replace the control panel
The color of the panel is very faded	The LCD screen is damaged	Replace the control panel
There are some vertical or horizontal lines on the control panel	The LCD screen is damaged	Replace the control panel
The control panel does not respond	The LCD screen is damaged	Replace the control panel
The control panel flickers	The LCD screen could be damaged	Wait for about 5 minutes. If the issue persists, replace the control panel
The buzzer does not sound	The control panel is defective	Replace the control panel
Contactors are chattering	Some metal dust is on the contact / the relay on the power board is defective	<p>Measure between PIN A1 and A2 of the contactor the power supply, with the multimeter set to V AC. Do you have a stable value of voltage, around 230 V AC?</p> <ul style="list-style-type: none"> · If not, replace the power board · If yes, try to set any cooking program and open and close the door while the oven is running. Does the issue persist? <ul style="list-style-type: none"> - If yes, try to clean the contact of the contactors with compressed air. Does the issue persist? - If yes, replace the contactors

SPIDO.Gas™ Theory and practice

Introduction	103
Gas circuit - mechanical system	103
Maintenance of the mechanical gas system	105
Gas circuit – electrical system.....	109
Appendix 1 - PRO100493/A MIND.Maps™ Gas units: Installation.....	123

INTRODUCTION

MIND.Maps™ SPIDO.Gas™ gas ovens technology is based on the pre-mix blower system that takes advantage of a blower connected directly to the gas valve.

The core of the SPIDO.Gas™ system is composed of:

- Gas valve with blower;
- Heat exchangers with integrated baffle;
- Igniter;
- Flame control board;
- Gas board;
- Burners.

The burner is where the reaction of the fuel takes place with the oxidizer (usually oxygen from air) to convert the chemical energy of the fuel into thermal energy.

GAS CIRCUIT - MECHANICAL SYSTEM

SPIDO.Gas™ mechanical system is composed of:

- Two heat exchangers with integrated baffles. The baffle flange is welded to the heat exchanger flange;
- Two flanges are placed at the ceiling of the cooking cabinet. The two heat exchanger flanges are fixed to the cooking cabinet flanges;
- Two Fiberglass sealing cords between the heat exchanger flange and the cooking cabinet ceiling locking flange;
- Two Burners. The burner is composed of a metallic fibre mesh torch, a flange, two ignition electrodes and a flame detection electrode;
- Two metallic rings and two fiberglass sealing cords placed at the base of the heat exchangers;
- Two fiberglass gaskets placed between the flange of the burner and the base of the heat exchanger;
- Copper washer gaskets for the fixing nuts of the burners.

The system is designed to be watertight guarantee.

For that reason, the flange of the burner is fixed to the bottom side of the oven with four studs and brass nuts.

The burner flange is fixed to the bottom of the heat exchanger with three studs and brass nuts. At the base of the heat exchanger there are two metal rings and two fiberglass cords. In the system the metal rings and the fiber glass cords are placed alternately; in the previous system the metal rings are placed in contact with the cooking cabinet.

For all the units produced with serial number 2015G00XXXXX – 2017K0092568, the burner was fixed to the heat exchanger by means of three studs. Starting from the serial number 2017K0092569 the gas system is composed of:

- A burner fixed to the heat exchanger by using two studs and two locking bars used to prevent the screws from getting loose;
- Two studs and brass nuts instead of three;
- Extended length of the gas pad to make assembly and maintenance easier.

Figure 1, Figure 2 and **Figure 3** show the previous system and the current system.

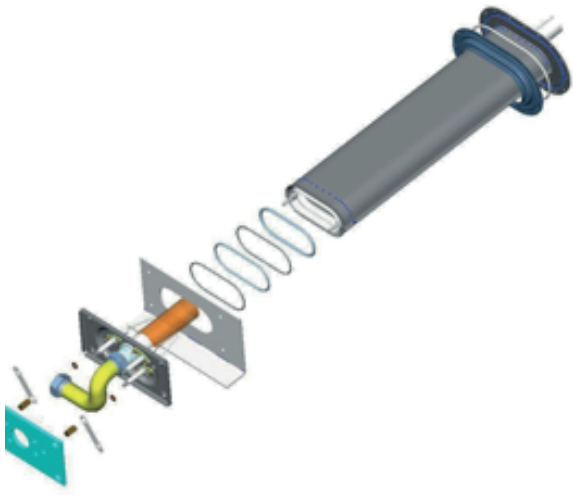

Figure 1
Previous Gas circuit - mechanical part

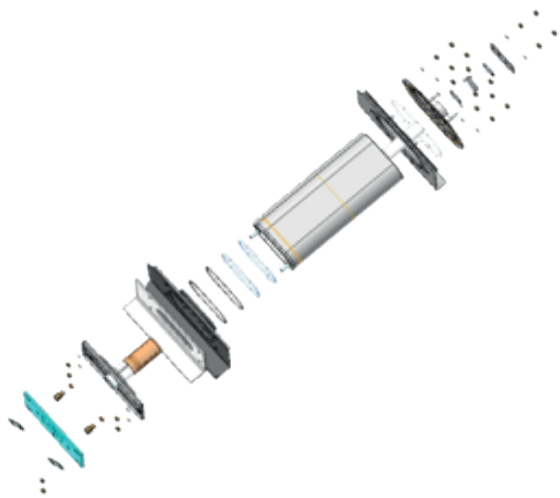

Figure 2
Current Gas circuit - mechanical part

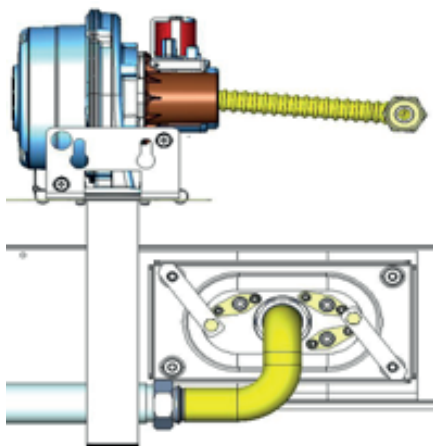

Figure 3
New gas part extension

MAINTENANCE OF THE MECHANICAL GAS SYSTEM

The main alarm related to the gas system failure is the AF23. Starting from software version 24570 released on June 08th, 2016 that alarm has been split into multiple alarms. **Figure 4** shows the meaning of the various AF23 alarms.

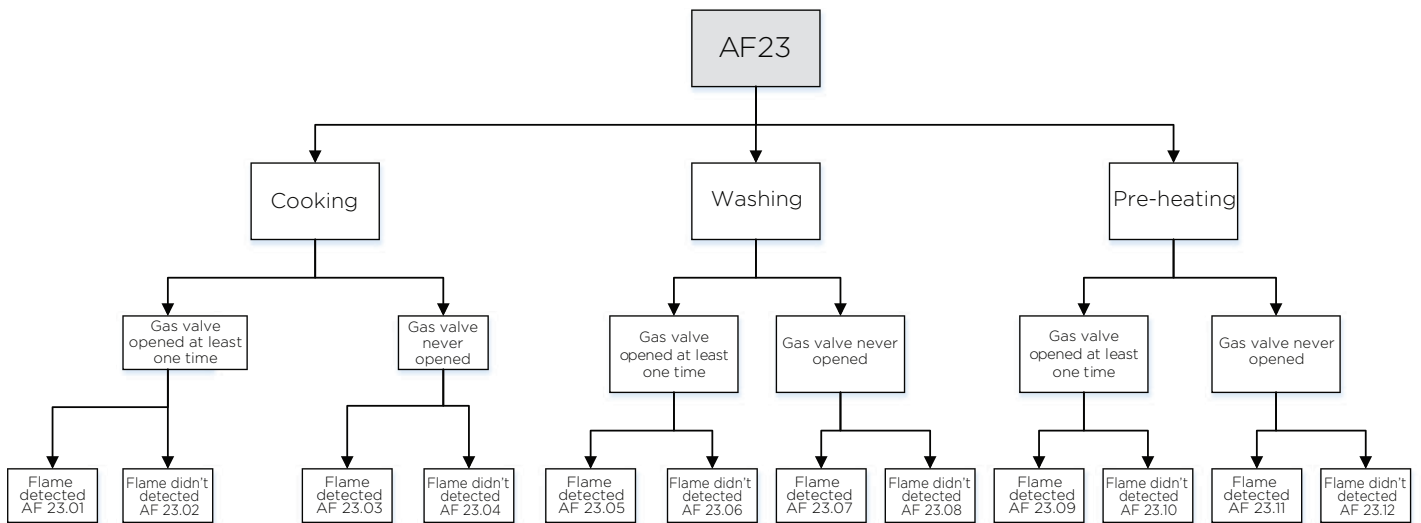

Figure 4
AF23 gas alarm

When the oven triggers the AF23 alarm, the display shows you a string of value like X|Y|Z|W which mean:

- X = temperature of the cooking chamber when the alarm triggered;
- Y = number of times the oven successfully ignited at the first ignition attempt;
- Z = number of times the oven successfully ignited at the second ignition attempt;
- W = number of times the oven successfully ignited at the third ignition attempt.

The oven could trigger an AF23.00.
In one of the following modes:

- door opened;
- in-between the preheating and cooking step;
- manual stop of any programs.

When the SD card integrated in the control panel is corrupted the oven will show a different set of alarms:

- AF27 ➡ AF23.01
- AF28 ➡ AF23.02
- AF29 ➡ AF23.03
- AF30 ➡ AF23.04
- AF31 ➡ AF23.05
- AF32 ➡ AF23.06
- AF33 ➡ AF23.07
- AF34 ➡ AF23.08
- AF35 ➡ AF23.09
- AF36 ➡ AF23.10
- AF37 ➡ AF23.11
- AF38 ➡ AF23.12

► Replacement of the ignition and flame detection plugs and also the proper ignition and flame detection electrode gaps

Necessary tools:

- 13 mm wrench
 - 7 mm spanner (better if flexible)
 - Phillips screwdriver (PH2x25)
 - Parrot nose pliers
 - 36 mm open end wrench
- a) Disconnect the cable harness of the ignition and flame detection electrodes (by pulling the connection down) as shown in Figure 5.

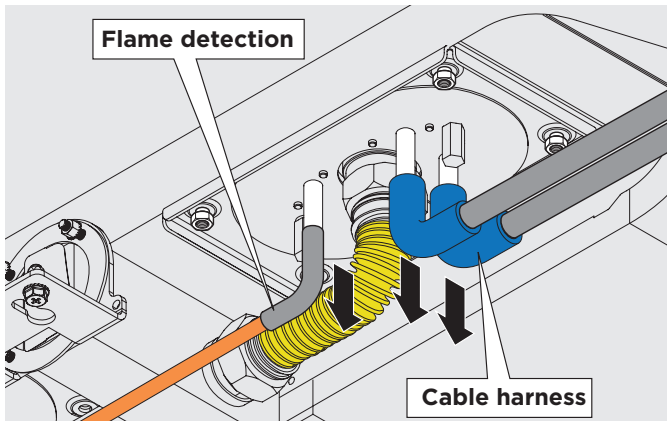

Figure 5

How to disconnect the cable harness of ignition and flame detection electrodes

- b) Disconnect the feeding air/gas pipe from the blower pad as shown in Figure 6 by using a parrot nose pliers.

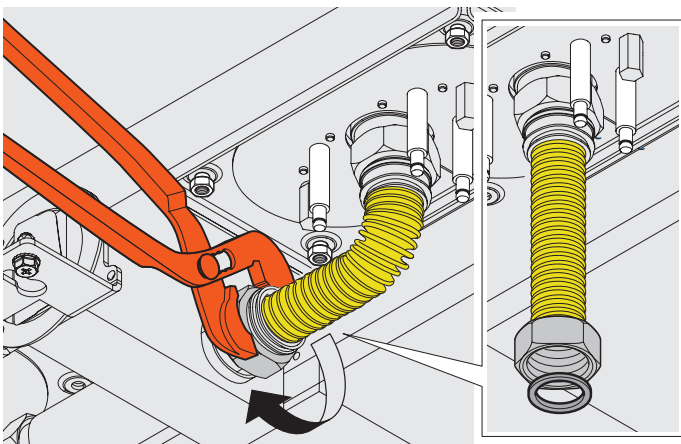

Figure 6

How to remove the feeding air/gas pipe

- c) Remove the four screws of the torch plate and the 2 or 3 rods nuts that hold each heat exchanger as shown in Figure 7.

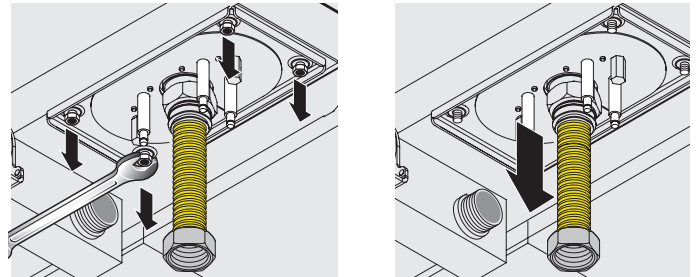

Figure 7

- d) Remove the torch by sliding sideways as shown in the Figure 8. In case of countertop oven, lift the oven (about 2 cm) and slide the torch sideways.
- Attention: the gasket between the two plates must be replaced before fitting the torch.

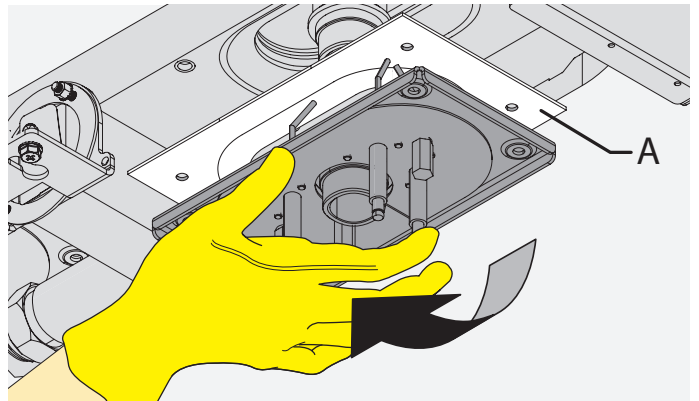



Figure 8

How to remove the torch

- e) Once you have removed the torch, replace the three electrodes per torch ensuring they are fitted with the proper gap as outlined below (please see Figure 9 to check the proper electrode distances):
- Distance between the two ignition electrodes ► 3 mm
 - Distance between the ignition electrodes and the torch ► 7 mm
 - Distance between the flame detection electrode and the torch) ► 7 mm (4 mm for floor standing units).
 -  To align the distance between the electrodes, use one clamp to hold the ceramic part and one clamp to adjust the metal element.

If you note metal dust at the base of the torch, please remove it and clean the ceramic part of the electrode carefully. The baffles of the heat exchanger are made of AISI 310S stainless steel.

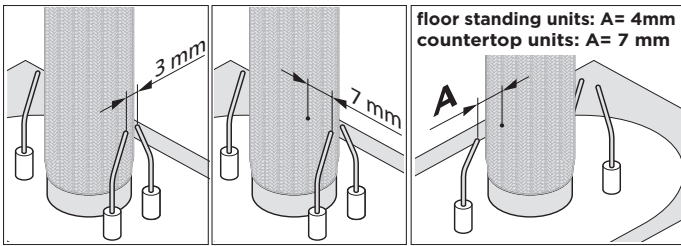

Figure 9

How to align the distance between the electrodes:

f) Once the new torch has been fitted, use a gas leak detector for investigating any gas leakage.

g) On the bottom of the heat exchanger, the two metal rings and two glass wool cords are placed to ensure the sealing shown in the **Figure 10**.

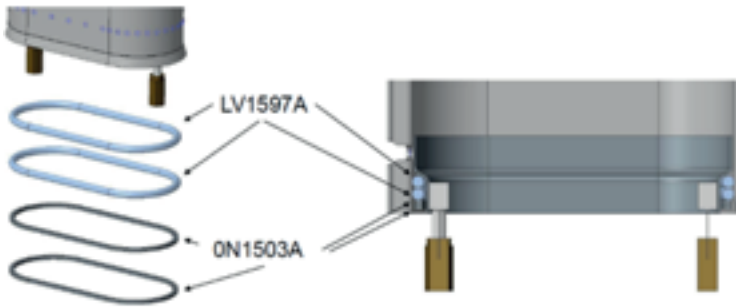

Figure 10

- h) Install the new sealing/isolation part that is called [KGN1569A](#) as shown on Figure 11.



Figure 11

► Measurement of the inflow and outflow gas pressure



Necessary tool:

- Differential pressure meter , suggested model: Testo 510

How to measure the static and dynamic **inflow pressure**, see **Figure 12**:

1. Unscrew the inflow gas pressure screw and connect the differential pressure meter;
2. Open the gas tap;
3. Read the static pressure value. The optimal value depends on the gas type according to UNOX specification;
4. Measure the inflow dynamic gas pressure while running the gas fumes test 1 (maximum power) and the gas fumes test 2 (minimum power). The values should be closed to the static value.

How to measure the static and dynamic **outflow pressure**, see **Figure 12**:

1. Unscrew the outflow gas pressure screw and connect the differential pressure meter;
2. Open the gas tap and run the oven;
3. Read the pressure value. The value should be idea 0 ± 0.7 mbar (0 ± 0.28 inch wc);
4. Measure the static outflow gas pressure and check if the value is about 0 mbar (0 in H₂O);
5. Measure the dynamic outflow gas pressure when running the gas fumes test 1 (maximum power) and the gas fumes test 2 (minimum power). The values should be about 0 ± 0.7 mbar (0 ± 0.28 In H₂O) as explained in **section 4.4 Influence of the gas valve inflow pressure**.

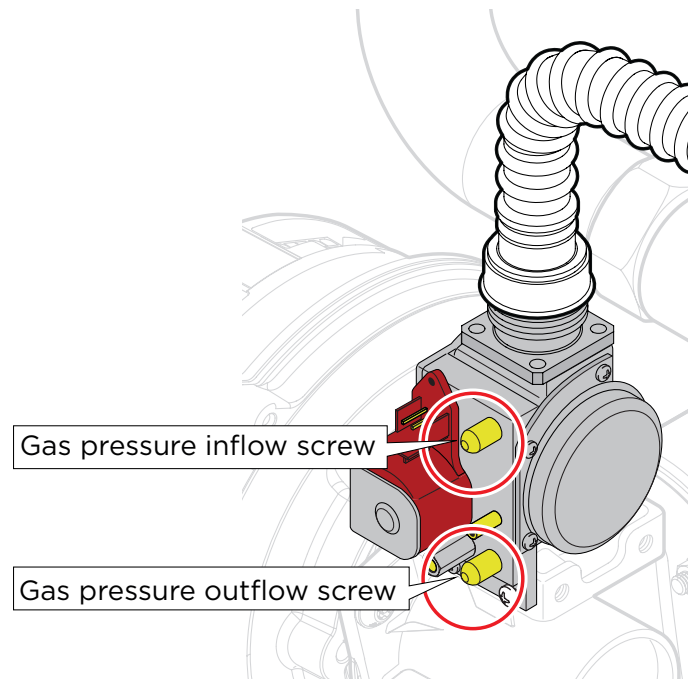

Figure 12

Measurement of the inflow and outflow pressure

GAS CIRCUIT – ELECTRICAL SYSTEM

SPIDO.Gas™ electrical system is composed of:

- One power board for the CHEFTOP MIND.Maps™,
- Two power boards for the New CHEFTOP MIND.Maps™ BIG,
- One flame control board for European models; two flame control boards for US models,
- Two igniters,
- Two pair of ignition electrodes,
- One flame detection electrodes,
- Two pair of ignition cables,
- One flame detection cables,
- One blower for all European models except XEVC-2021-GPX, XAVC-16FS-GPX, and also the New CHEFTOP MIND.Maps™ BIG,
- One gas valve.

The European gas valve is powered by the power board at around 230 V DC; the US gas valve is powered by the power board at 120 V DC.

In the US gas system, the two flame control boards work synchronized, therefore both flame control boards must detect the flame at the same time or the unit will lock out.

European electrical system

European gas ovens come with power board PE2021A up to the end of 2016, PE2021B was used from the beginning of 2017 and PE2021C was used from the September 2019. The main features of the board are:

- Control the 230 V AC loads of the oven such as motors, contactors, braking elements, solenoid valve, chemical pump, cooling fan, DRY.Maxi solenoid valve;
- Read the values measured by the oven sensors such as door switch, core probe, temperature probes, motor revolution sensor, etc.;
- Control the flame control board BRAHMA ECM-113;
- Control up to two blowers for the air-gas mixture;
- Feed the 12 V DC loads of the oven such as control panel, LED bar light, etc.;
- Communicate in CANBUS mode with the control board and accessory boards such as gas fumes board, internet connection board and sous-vide board;
- Communicate in MODBUS mode with UNOX complementary accessories such as proofer, hood, holding cabinet and static oven;
- Switch the phase polarity automatically. In case of the wrong polarity, without the relay for switching, the flame control board would not detect the flame.

European gas unit power board

Gas power board sockets are summarized **Table 22**

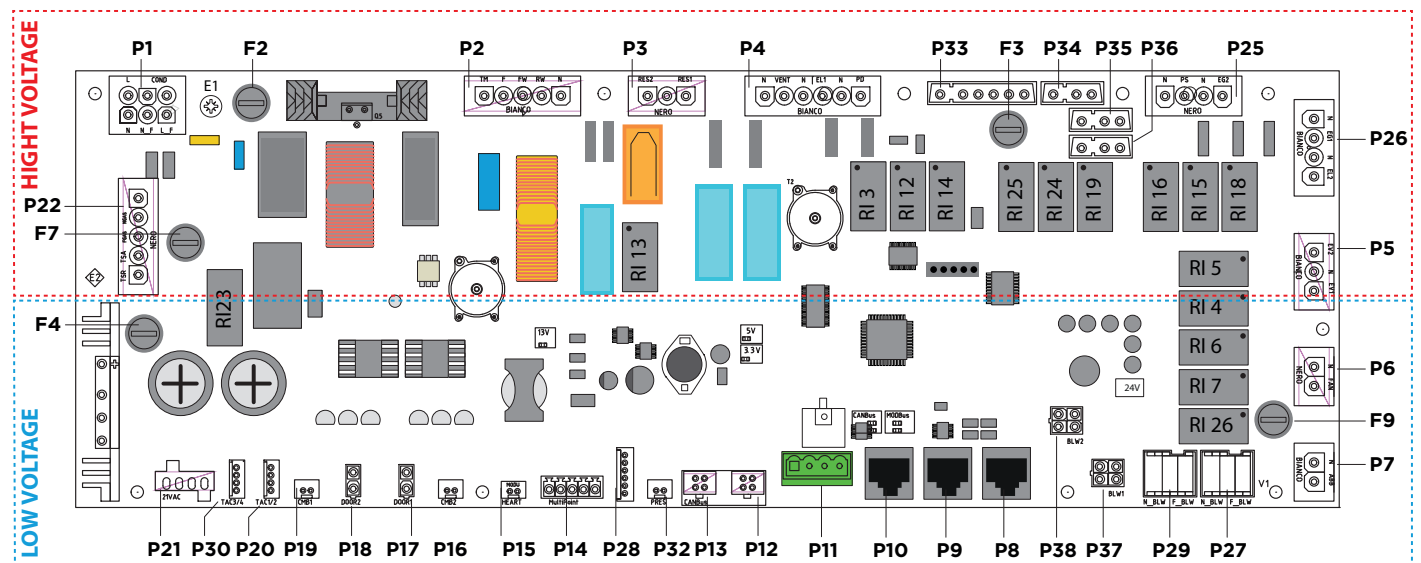

PE2021A0 - gas unit power board

Table 22

PE2021A0 sockets

N° OF SOCKET	SOCKET TYPE	N° PIN	LABEL	DESCRIPTION	
P33	STELVIO 6P 1F	1	-	Input flame control board gas alarm	
		2		2 Output reset flame control board	
		3		3 Protected neutral flame control board	
		4		-	
		5		Heat demand 1 output	
		6		Heat demand 2 output	
P34	STELVIO 3P 1F	1	-	Gas valve power supply - Neutral - (bridge connection)	
		2		-	
		3		Gas valve power supply - Phase - (bridge connection)	
P35	STELVIO 3P 1F	1	-	Gas valve power supply - Neutral - (bridge connection)	
		2		-	
		3		Gas valve power supply - Phase - (bridge connection)	
P36	STELVIO 3P 1F	1	-	Gas valve power supply - Neutral - (bridge connection)	
		2		-	
		3		Gas valve power supply - Phase - (bridge connection)	
P27	RAST-5 3P 1F	1	F_BLW	Premix power supply - Phase	
		2		-	
		3	N_BLW	Premix power supply - Neutral	
P29	RAST-5 3P 1F	1	F_BLW	Premix power supply - Phase	
		2		-	
		3	N_BLW	Premix power supply - Neutral	
P37	MOLEX Minifit 4P 2F	1	BLW1	24VDC	
		2		Input tachometer blower 1	
		3		Output control blower 1 - PWM (0-24Vdc) @4kHz	
		4		GNG (ground connection)	
P38	MOLEX Minifit 4P 2F	1	BLW2	24VDC	
		2		Input tachometer blower 2	
		3		Output control blower 2 - PWM (0-24Vdc) @4kHz	
		4		GNG (ground connection)	
P28	AMP Modu II 6P	1	-	Potentially free contact 1	
		2		GNG (ground connection)	
		3		Potentially free contact 2	
		4		GNG (ground connection)	
		5		Potentially free contact 3	
		6		GNG (ground connection)	
		2		GNG (ground connection)	
P15	AMP Modu II 2P	1 2	-	Single point core probe input	
P16	JST XHP-2	1	CMB2	IN	Top temperature probe in oven with the smoker predisposition)
		2		GND	
P17	MOLEX Minifit 2P	1	DOOR1	IN	Door switch 1 input
		2		GND	
P18	MOLEX Minifit 2P	1	DOOR2	IN	Door switch 2 input (only used in trolley ovens)
		2		GND	

P19	JST XHP-2	1	CMB1	IN	Bottom temperature probe in oven with the smoker predisposition)
		2		GND	
P20	AMP Modu II 4P	1	TAC1/2	+13V	Tachometer input TAC1 e TAC2
		2		IN_ TAC1	
		3		IN_ TAC2	
		4		GND	
P30	AMP Modu II 4P	1	TAC3/4	+13V	Tachometer input TAC3 e TAC4
		2		IN_ TAC3	
		3		IN_ TAC4	
		4		GND	
P21	MOLEX Minifit 4P	1	21VAC	21V ac	21 V AC power supply from secondary transformer
		2		21V ac	
		3	12VAC	12V ac	12 V AC power supply from secondary transformer
		4		12V ac	
P22	INARLOCK 5P 1F (Black)	1	-	-	
		2	NGAS	Flame control board power supply - neutral	
		3	FGAS	Flame control board power supply - phase	
		4	TSA	Safety thermostat outward	
		5	TSR	Safety thermostat comeback	
P32	JST XHP-2	1	PRES	IN	Pressure switch potential free input
		2		GND	GND
P24	MOLEX Microfit 6P	1 ÷ 6	-	-	
E1	fixing screw	1	E1	Ground connection nut	
E2	fixing screw	1	E1	Ground connection nut	

Gas power board is equipped with 5 fuses. The function of these fuses are summarized in **Table 23**.

Table 23

PE2021A0 and PE2021B0 gas board fuses

N° OF FUSE	NOMINAL CURRENT	NOMINAL VOLTAGE	TYPE	PROTECTED CIRCUIT
F2	2A	250V	Fast (F)	Primary of the transformer (TR60 230V-12V 60VA)
F3	2A	250V	Fast (F)	Detergent pump (PD output on P4 socket)
F4	4A	250V	Time delay (T)	Secondary of the transformer (TR60 230V-12V 60VA)
F7	2A	250V	Fast (F)	Flame control board BRAHMA ECM113
F9	2A	250V	Fast (F)	Blowers premix gas

European flame control board

The BRAHMA ECM-113 flame control board is equipped with non-volatile lock-out, which means that a restart from the safety shutdown condition can be accomplished only by a manual reset of the system.

The main technical data are summarized in **Table 24**.

Table 24

Brahma technical data

DATA	RANGE
Supply Voltage	100/240V-50/60Hz
Operating temperature range	-20°C +85°C
Ambient humidity	95% max at 40°C
Protection degree	IP 00
Spark Ignition time (TSP)	(TS - 1) s
Response time in case of flame failure	< 1 s
Lockout time due to parasite flame (Tk)	1..60s
Recycling attempts	0..10

Maximum Power Consumption	@230Vac 15VA
Internal fuse rating:	3.15A Time-delay
External fuse rating (suggested)	2.5A Fast-blow
Minimum ionization current	0.5 μ A
On request	0.15 μ A
Recommended minimum ionization current times	3/5

The main connections of the flame control board are summarized in **Table 25** and shown in **Figure 12**.

Table 25

Flame control board connection

Connector:	J6
Pin 15	Phase
Pin 16	Neutral
Pin 17	Live lockout or residual heat signal
Pin 18	Remote Unlock
Pin 19	Neutral Unlock/Lockout Signal
Connector J2	Ignitor Line
Connector J3	Ignitor Neutral
Connector:	J4
Pin 11	Ground
Pin 12	Detection electrode n°1
Pin 13	Detection electrode n°2
Pin 14	Detection electrode n°3
Connector:	J5
Pin 8	Gas Valve Line
Pin 9	Not used
Pin 10	Gas Valve Neutral
Connector:	J1
Pin 1	Led output signal
Pin 2	Selectors Neutral
Pin 3	Selector or heating demand on burner/fire 1
Pin 4	Selectors Neutral
Pin 5	Selector or heating demand on burner/fire 1
Pin 6	Selectors Neutral
Pin 7	Selector or heating demand on burner/fire 1

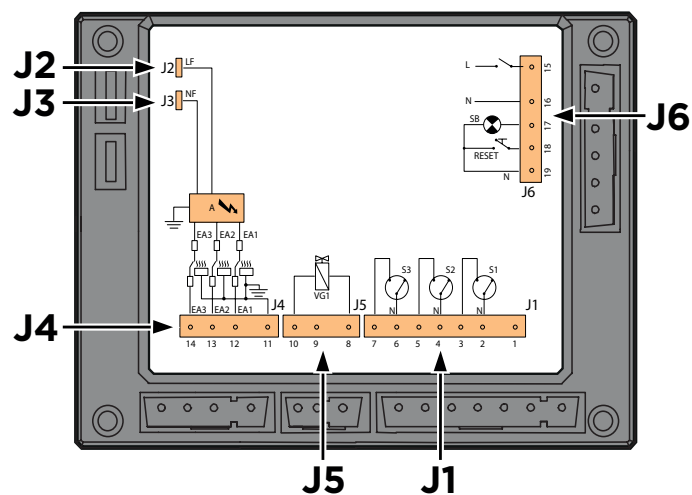



Figure 13

Flame control board

Ignition sequence

The ignition sequence is described below as shown in **Figure 14**:

1. The control board sends the heat demand input to the power board;
2. The power board receives the input and transmits it to the flame control board, through the power board socket P33;
3. The flame control board activates the blower by using the power board socket P27 or P29;
4. After the startup of the blower, the flame control board produces the ignition sparks by providing 230 V AC to the ignition electrodes or the contactor, through the flame control board sockets J2 and J4;
5. The flame control board opens the gas valve, sending the input from the J5 flame control board socket to the P34 power board socket of the power board and then from the P35 or P36 to the gas valve. The power board supplies 230 V AC to the gas valve, the gas valve receives 230 V DC due to a rectifier placed in the cable harness.

 There can be a maximum of 3 ignition attempts in total, after that the oven will trigger an AF23 alarm

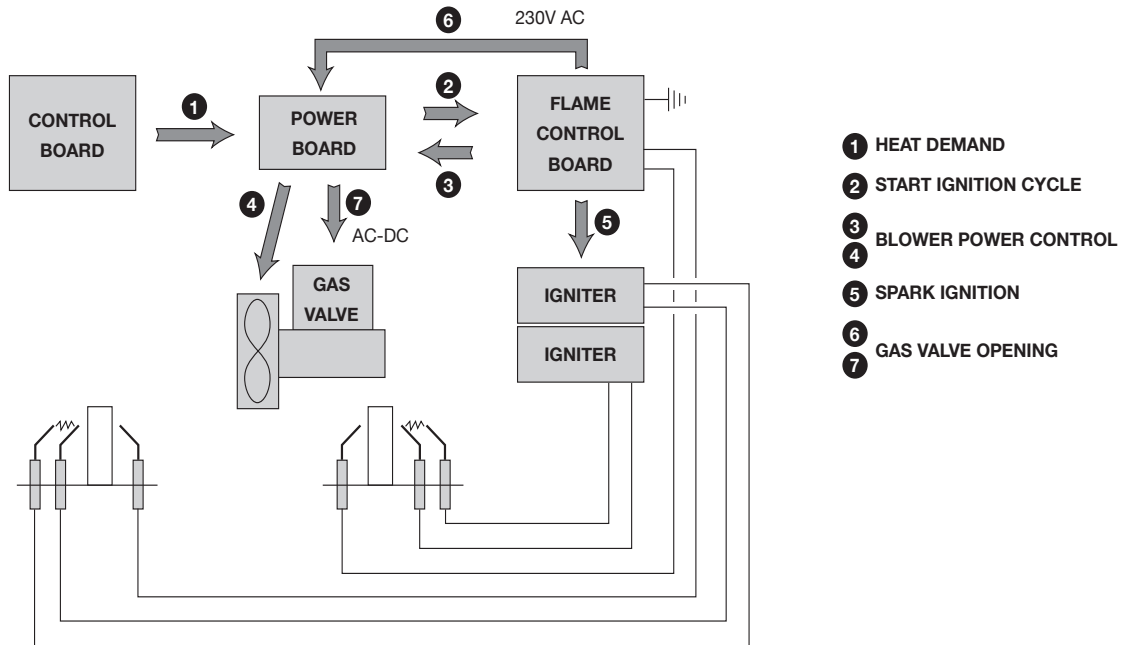

Figure 14

Ignition sequence EU system



US electrical system

US units are equipped with two Brahma TGRD81 flame control boards installed for each oven. The two flame control boards work synchronized and both must give the power input to the gas valve to make it open.

⚠ There can be a maximum of 3 ignition attempts in total, after that the oven will give an AF23 alarm.

N° OF SOCKET	SOCKET TYPE	N° PIN	LABEL	DESCRIPTION
P1	INARLOCK 6P 2F (White)	1	N	Board power neutral
		2	N_F	Transformer power supply (filtered neutral)
		3	L_F	Transformer power supply phase
		4	L	Board power supply phase
		5	COND	Capacitor for the motor startup
		6	COND	Capacitor for the motor startup
P2	INARLOCK 5P 1F (White)	1	N	Neutral
		2	RW	Motor power supply -counterclockwise spinning
		3	FW	Motor power supply -clockwise spinning
		4	F	Phase 230 Vac
		5	TM	Motor thermal protection input
P3	INARLOCK 3P 1F (Black)	1	RES1	Braking element 1
		2		
		3	RES2	Braking element 2
P4	INARLOCK 6P 1F (White)	1	PD	Detergent pump phase
		2	N	Detergent pump neutral
		3	EL1	Water solenoid valve EL1 phase
		4	N	Water solenoid valve EL1 neutral
		5	VENT	DRY.Maxi output
		6	N	DRY.Maxi output - neutral
P33	STELVIO 6P 1F	1		Input flame control board gas alarm
		2		Output reset flame control board
		3		Protected neutral flame control board
		4	-	-
		5	-	Heat demand output 1
		6	-	Heat demand output 2
P41	STELVIO 6P 1F	1	-	Input flame control board gas alarm
		2		Output reset flame control board
		3		Protected neutral flame control board
		4		-
		5		Heat demand output 1
		6		Heat demand output 2
P34	STELVIO 3P 1F	1	-	Gas valve power supply - Neutral - (bridge connection)
		2		-
		3		Gas valve power supply - Phase - (bridge connection)
P35	STELVIO 3P 1F	1	-	Gas valve power supply - Neutral - (bridge connection)
		2		-
		3		Gas valve power supply - Phase - (bridge connection)
P36	STELVIO 3P 1F	1	-	Gas valve power supply - Neutral - (bridge connection)
		2		-
		3		Gas valve power supply - Phase - (bridge connection)
P39	RAST-5 2P 1F	1	-	Line 120 V
		2		Neutral protected by TM
P40	RAST-5 2P 1F	1	-	Line 120 V
		2		Neutral protected by TM
P27	RAST-5 3P 1F	1	F_BLW	Premix power supply - Phase
		2	-	-
		3	N_BLW	Premix power supply - Neutral

US gas unit power board

US gas ovens is equipped with power board PE2022A0. This board integrates the functionality of the gas system. Its main functions are:

- Control the 230 V AC loads of the oven such as motors, contactors, braking elements, solenoid valve, chemical pump, cooling fan, DRY.Maxi solenoid valve;
- Read the values measured by the oven sensors such as door switch, core probe, temperature probes, motor revolution sensor, etc.;
- Control the flame control boards BRAHMA TGRD8I;
- Control up to two blowers for the air-gas mixture;
- Feed the 12 V DC loads of the oven such as control panel, LED bar light, etc.;
- Communicate in CANBUS mode with the control board and accessory boards such as gas fumes board, internet connection board and sous-vide board;
- Communicate in MODBUS mode with UNOX complementary accessories such as proofer, hood, holding cabinet and static oven;

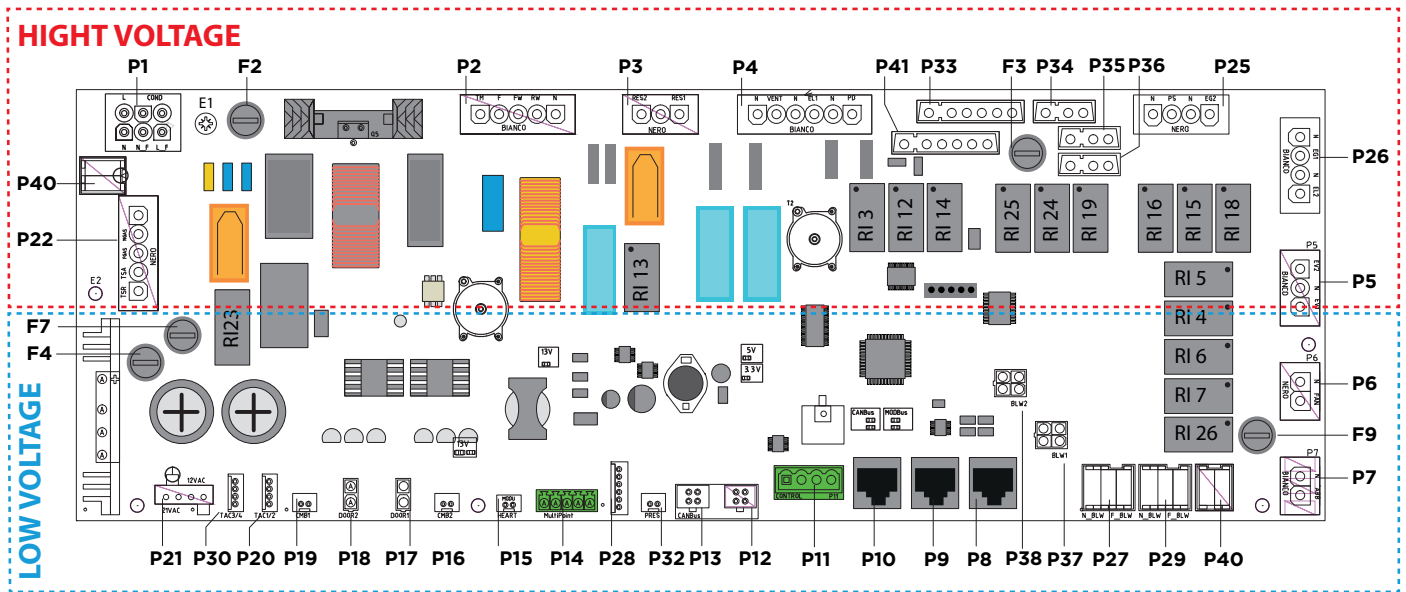

N° OF SOCKET	SOCKET TYPE	N° PIN	LABEL	DESCRIPTION
P29	RAST-5 3P 1F	1	F_BLW	Premix power supply - Phase
		2		-
		3	N_BLW	Premix power supply - Neutral
P25	4P 1F (Black)	1	EG2	Water solenoid valve EG2 solenoid output - phase
		2	N	Water solenoid valve EG2 solenoid output - neutral
		3	PS	-
		4	N	-
P26	4P 1F (White)	1	EL2	Water solenoid valve EL2 solenoid output - phase
		2	N	Water solenoid valve EL2 solenoid output - neutral
		3	EG1	Water solenoid valve EG1 solenoid output - phase
		4	N	Water solenoid valve EG1 solenoid output - neutral
P5	3P 1F (White)	1	EV1	EV1 Phase high flow rate
		2	N	Common neutral output EV1 and EV2
		3	EV2	EV2 Phase low flow rate
P6	2P 1F (Black)	1	FAN	Cooling fan output - phase
		2	N	Cooling fan output - neutral
P7	2P 1F (White)	1	ABB	Drainage cooling water solenoid output -phase
		2	N	Drainage cooling water solenoid output -neutral
P37	MOLEX Minifit 4P 2F	1	BLW1	24VDC
		2		Input tachometer blower 1
		3		Output control blower 1 - PWM (0-24Vdc) @4kHz
		4		GND (ground connection)

P38	MOLEX Minifit 4P 2F	1	BLW2	24VDC	
		2		Input tachometer blower 2	
		3		Output control blower 2 - PWM (0-24Vdc) @4kHz	
		4		GND (ground connection)	
P8	RJ PLUG 8 contacts 90°	1	-	+13V	Accessory board 1 connection (MODBUS)
		2		GND	
		3		A	
		4		B	
		5		+12V	
		6		GND	
		7		GND	
		8		+13V	
P9	RJ PLUG 8 contacts 90°	1	-	+13V	Accessory board 2 connection (MODBUS)
		2		GND	
		3		A	
		4		B	
		5		+13V	
		6		GND	
		7		GND	
		8		+13V	
P10	RJ PLUG 8 contacts 90°	1	-	+13V	Accessory board 3 connection (MODBUS)
		2		GND	
		3		A	
		4		B	
		5		+13V	
		6		GND	
		7		GND	
		8		+13V	
P11	CPM 4P-5P08	1	CONTROL	+13V	Control board connection (CANBUS)
		2		B	
		3		A	
		4		GND	
P12	MOLEX Microfit 4P	1	-	+13V	Bridge board connection (CANBUS)
		2		B	
		3		A	
		4		GND	
P13	MOLEX Microfit 4P	1	-	+13V	Bridge board connection (CANBUS)
		2		B	
		3		A	
		4		GND	
P28	AMP Modu II 6P	1	-	Potentially free contact 1	
		2		GND (ground connection)	
		3		Potentially free contact 2	
		4		GND (ground connection)	
		5		Potentially free contact 3	
		6		GND (ground connection)	
		2			
P14	CPM-5P-3P81	1	MultiPoint	IN1	Multi point core probe input
		2		IN2	
		3		IN3	
		4		IN4	
		5		GND	

P15	AMP Modu II 2P	1	-	Single point core probe input	
		2			
P16	JST XHP-2	1	CMB2	IN	Top temperature probe
		2		GND	
P17	MOLEX Minifit 2P	1	DOOR1	IN	Door switch 1 input
		2		GND	
P18	MOLEX Minifit 2P	1	DOOR2	IN	Door switch 2 input (only used in trolley ovens)
		2		GND	
P19	JST XHP-2	1	CMB1	IN	Bottom temperature probe
		2		GND	
P20	AMP Modu II 4P	1		+13V	
		2		IN_TAC1	
		3	TAC1/2	IN_TAC2	Tachometer input TAC1 and TAC2
		4		GND	
P30	AMP Modu II 4P	1		+13V	
		2		IN_TAC3	
		3	TAC3/4	IN_TAC4	Tachometer input TAC3 and TAC4
		4		GND	
P21		1	21VAC	21V ac	12 V AC power supply from secondary transformer
		2		21V ac	
		3	12VAC	12V ac	12 V AC power supply from secondary transformer
		4		12V ac	
P22	INARLOCK 5P 1F (Black)	1	-	-	-
		2	NGAS	Flame control board power supply - neutral	
		3	FGAS	Flame control board power supply - phase	
		4	TSA	Safety thermostat outward	
		5	TSR	Safety thermostat comeback	
P32	JST XHP-2	1	PRES	IN	Pressure switch potential free input
		2		GND	GND (ground connection)
P24	MOLEX Microfit 6P	1÷ 6	-	-	-
E1	fixing screw	1	E1	Ground connection nut	
E2	fixing screw	1	E1	Ground connection nut	

Gas power board is equipped with 5 fuses. The functions of these fuses are summarized in **Table 26**

Table 26

PE2022A gas board fuses

N° OF FUSE	NOMINAL CURRENT	NOMINAL VOLTAGE	TYPE	PROTECTED CIRCUIT
F2	2A	250V	Fast (F)	Primary of transformer (TR60 230V-12V 60VA)
F3	2A	250V	Fast (F)	Detergent pump (PD output on P4 socket)
F4	4A	250V	Time delay (T)	Secondary of transformer (TR60 230V-12V 60VA)
F7	2A	250V	Fast (F)	BRAHMA TGRD81 flame control boards
F9	2A	250V	Fast (F)	Blowers premix gas 120 VAC

US flame control board

BRAHMA TYPE TGRD8 1 flame control board is equipped with non-volatile lock-out, which means that a restart from the safety shutdown condition can be accomplished only by a manual reset of the system. The main technical data is summarized in **Table 27**.

Table 27

Brahma technical data

DATA	RANGE
Supply Voltage	100-120V @ 50-60 Hz
Operating temperature range	-20°C +70°C
Ambient humidity	95% max at 40°C
Protection degree	IP 00
Waiting/prepurge time (TW/TP)	1 ... 120 s
Safety time (TS) - GAS versions: TGRD6x – TGRD8x:	3 ... 120 s
Spark ignition time (TSP)	11 s
Response time in case of flame failure (GAS versions)	< 1 s
Recycle attempts	1 ... 10
Maximum Power Consumption	@230Vac 15VA
Minimum ionization current	0.5 µA
On request	0.15 µA
Recommended minimum ionization current times	3 - 5 times

The main connections of the flame control board are summarized in **Table 27** and shown in **Figure 15**.

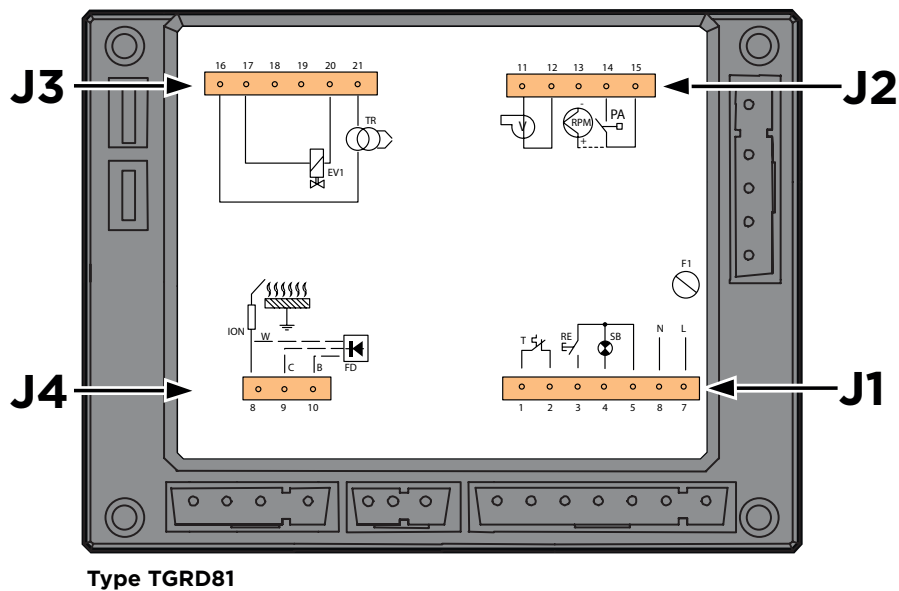















Figure 15

Ignition sequence scheme

Figure 15

TGRD81 flame control board connections

	Room thermostat		First stage valve		Ignition transformer
	Preheater		Second stage valve		Reset
	Preheater thermostat		Pilot valve		Ionization probe
	Air pressure switch or revolutions per minute		Photocell		Lockout signal
	Fan		Photodiode FD		

The whole electrical scheme of the US gas system is shown in **Figure 16**

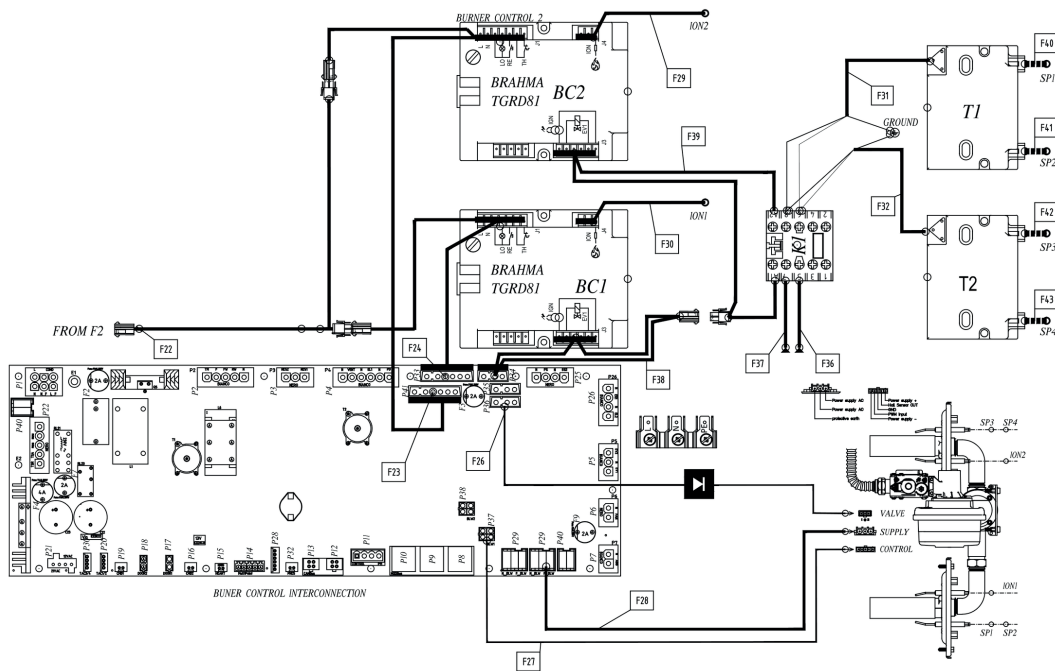

Figure 16

Electrical scheme for US gas ovens

3.2.3 Ignition sequence

The ignition sequence could be described as shown in **Figure 17** and listed as follow

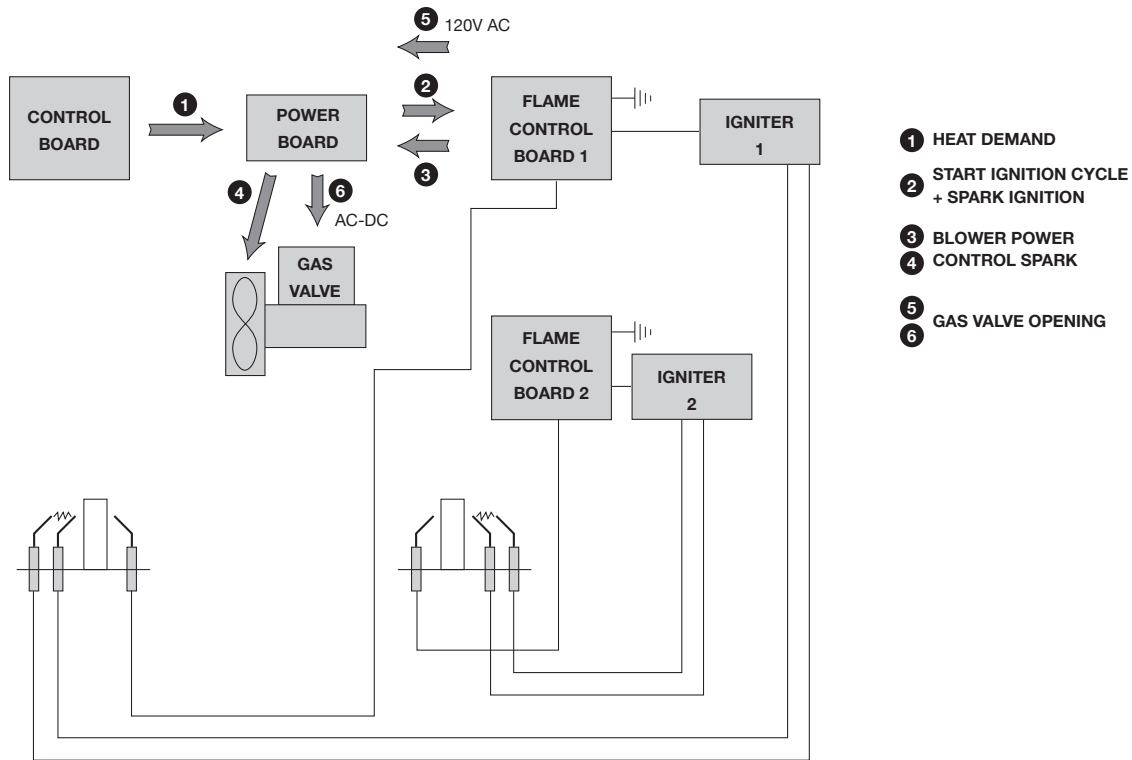

Figure 17
Ignition sequence for US system

► Maintenance of the electric part of the gas system

The US flame control board has an automatic diagnostic system. During different working conditions the flame control board shows multiple working status by means of multi-color LEDs:

- Steady **green light**, good status/flame sensed;
- Steady **orange** light, start up status;
- Steady **red** light, stop/gas block status;
- Flashing **green** light, working status with weak ionizing signal;
- Flashing **orange** light, start up status with good ionizing signal;
- Flashing **red** light, diagnostic stop status or parasitic flame current;
- Green and **orange** alternating light, start up status with weak ionizing signal;
- **Red** and **orange** alternating light, low/high voltage signal.

During the start up the system normally shows steady orange – flashing orange – steady green light. The system attempts three startup cycles every 5 seconds. The US gas oven has 2 flame control boards that work synchronized. The European flame control board does not use a diagnostic system.

- Ionization current;
- Blower speed;
- Visual check of the harnesses of the ignition and flame detection cables and electrodes.

The suggested instrument to perform these measurements is the Multimeter model: Fluke 116, see **Figure 18**.



Figure 18
Multimeter TRUE RMS FLUKE 116 with Microamps

Ionization current measurements

The ionization flame detection device makes use of the rectification property of the flame (ionization), as shown in **Figure 19**. The control system is more sensitive to the flame at starting or during waiting/prepurge time (negative differential switching).

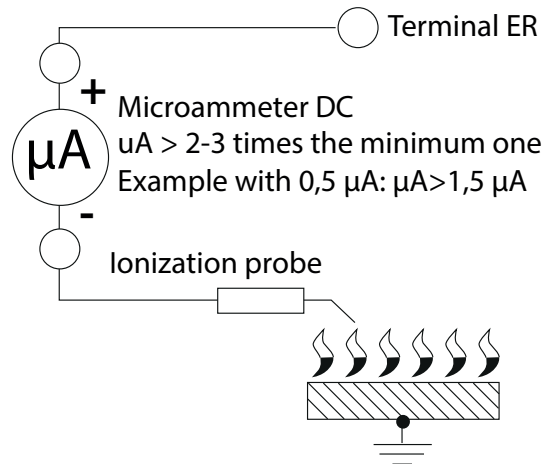

Figure 19
Ionization flame scheme

The ground terminal of the control system, the metal frame of the gas burner and the ground on the main supplies must have a good connection. Avoid putting the detection cable close to power or ignition cables. In case of “partial” short circuits or bad insulation between signal and ground the voltage on the detection electrode can be reduced making it impossible to detect the flame signal, resulting in a lockout of the control system. In order to measure the ionization current, the multimeter has to be connected in series between the flame control electrode and the flame control board. The value of the current measured should be in the range of 1.5 - 10 μA .

! This procedure is applicable only to the flame control plug.

- Disconnect the terminal of the flame control electrode as shown in Figure 20;

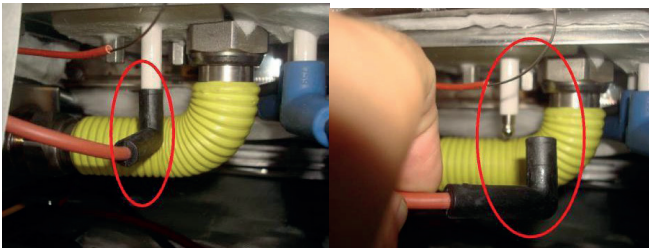

Figure 20
Flame control plug and flame control plug cable

- Connect the multimeter in series as described above by means of the two cables with the crocodile clamp to one of the flame control electrodes and to one of the internal metallic part of the terminal of the cable, as shown in Figure 21;



Figure 21
Multimeter connection to the flame control plug

- Set the multimeter to μA DC and run the oven by setting time = infinite and temperature = $260\text{ }^{\circ}\text{C}$ (500°F);
- Read the ionization current.

The flame detection plug is fine if the measured current is stable and between 1,5 to $10\ \mu\text{A}$.

Blower speed measurement

To measure the speed of the blower, set the multimeter to Hz. measure the frequency of the blower between the external pins that are close to the edge of the Powerboard on the sockets P37 or P38.

To calculate the blower speed, multiply the measured value by 30.

The blower speed test should be performed using gas fumes test 1 and gas fumes test 2 to get the maximum and minimum value respectively. Gas fumes test 1 and 2 correspond to the maximum and minimum power of the oven respectively.

While performing the measurement in gas fumes test 2 the expected value of Hz should be a value that is higher at the beginning and then step by step decreases down to a lower value.

DOUBLE IGNITER KIT

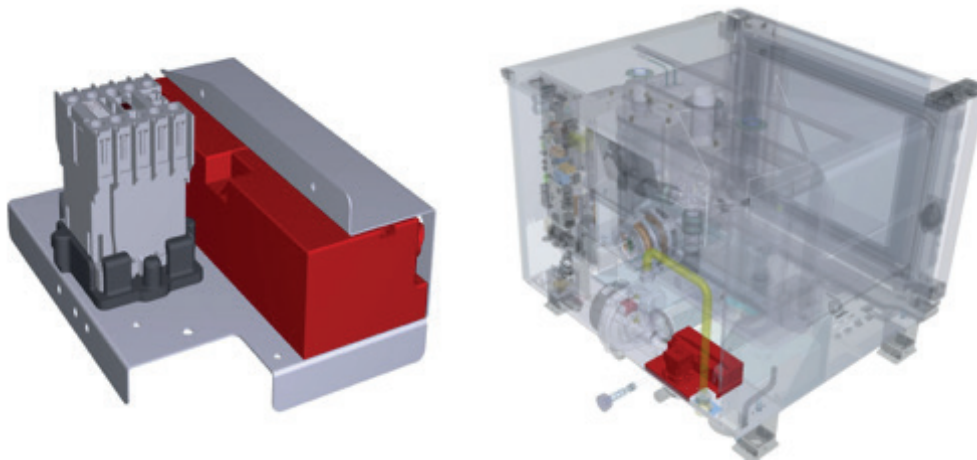
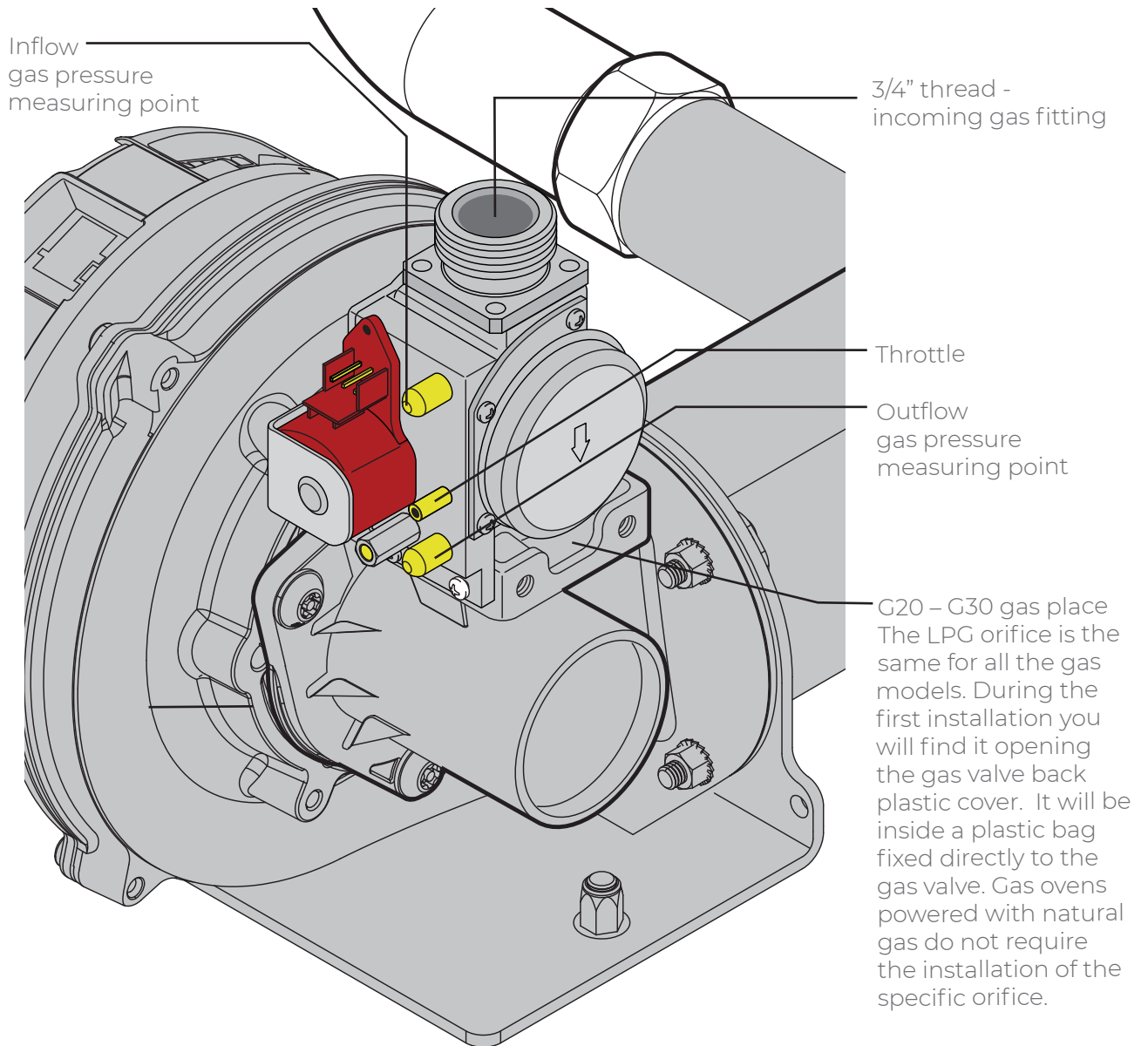

Figure 22

Double igniter with contactor system European and US markets have different kits due to the technical differences of the gas systems. For European markets, the XRF011 kit with the contactor integrated is available. This kit should be used to upgrade all the gas ovens experiencing backfiring problems. For the US market, the kits [XRF009](#) and [XRF010](#) are available. The [XRF009](#) is for floor standing models whilst [XRF010](#) is for countertop models. For the US market the contactor is already included.

APPENDIX 1 - PRO100493/A MIND.MAPS™ GAS UNITS: INSTALLATION





► Scope

The aim of the procedure is to describe the installation process of MIND.Maps™ gas ovens.

► Field of application

This procedure applies to technician who installs MIND.Maps™ gas ovens.

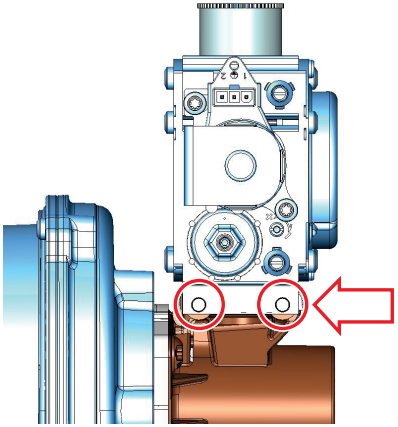
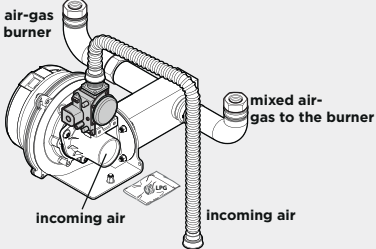
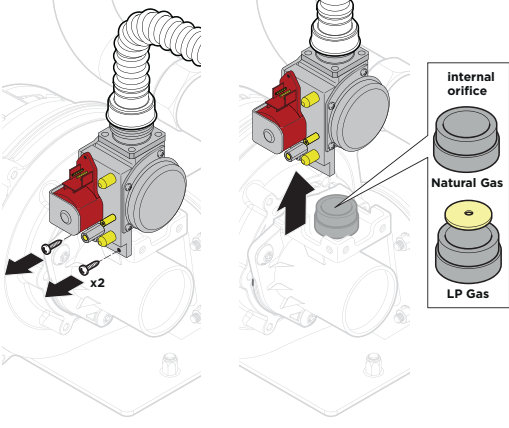
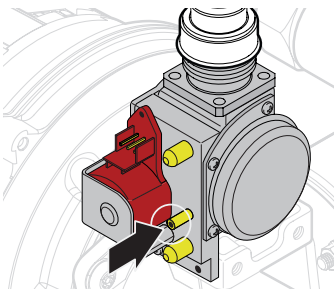
► Description

n° STEP	REQUIREMENT	TO DO LIST	ILLUSTRATION
1	Mandatory	Identify the type of gas G20,G25,G25.1,G25.3 or G110(Natural Gas) G30 or G31 (LPG)	
2	Step 1 -> G30, G31	Install the LPG gas orifice by removing the screws marked in red in the picture by means of a Torx T25 or T28 screw driver. The orifice has to be placed inside the black gasket between the gas valve and the blower. If the screw is hard to fix, proceed tapping the blower side with a M5 tapping drill. Be careful to avoid metal splinters from entering into the gas duct of the Venturi. 	
3	If you are using LPG gas G30 or G31	Adjust the throttle following the requirements of the gas setting table. Set gas parameter to G30,G31, G25,G25.1,G25.3 or G110 accordingly with the gas type. To set the parameter: - ① ② enter the service menu - ③ ④ type the PIN 99857 - ⑤ select OVEN SETUP - ⑥ select GAS - ⑦ select GAS TYPE. Once selected the parameter press HOME button ⑧. 	

n° STEP	REQUIREMENT	TO DO LIST	ILLUSTRATION								
4	If the oven is one of the following models: <ul style="list-style-type: none"> ■ XEVC-2021-GPX ■ XAVC-2021-GPX ■ XAVC-16FS-GPX 	Install the orifice and adjust the throttle of the second gas valve									
5	Mandatory GAS FUMES TEST 1	Perform the gas analysis test by choosing: - ① ② Enter the service menu - ③ ④ type the PIN 99857 - ⑤ select UTILITIES - ⑥ select CALIBRATION - ⑦ select GAS 1 FUMES TEST. The oven will start at maximum speed of the blower									
6	Combustion analyzer tool setting	Set the instrument for measuring CO [ppm] and CO2 [% v/v]. Set the gas type among G20, G25, G25.1, G25.3 G110 (natural gas), G30 (butane), G31 (propane).	<ol style="list-style-type: none"> 1. Switch the instrument on: Hold down [⏻], until all segments are shown on the display. 2. Open "Measurements configuration menu": Press right function key [set]. 3. Make settings: <ul style="list-style-type: none"> ⊕ Use [esc] to revert to the previous parameter at any time. <table border="1" style="width: 100%; border-collapse: collapse;"> <thead> <tr> <th style="width: 20%;">Display/param.</th> <th style="width: 80%;">Explanation</th> </tr> </thead> <tbody> <tr> <td>Fuel</td> <td> Selecting the area version activates different calculation formulas and measurement parameters, see Area versions. <ul style="list-style-type: none"> ■ Select the fuel: [▲] and [▼]. ■ Switch to the next parameter: [→]. ■ Exit the configuration menu: [OK]. </td> </tr> <tr> <td>Unit of pressure</td> <td> <ul style="list-style-type: none"> ■ Select the unit: [▲] and [▼]. ■ Switch to the next parameter: [→]. </td> </tr> <tr> <td>Unit of temperature</td> <td> <ul style="list-style-type: none"> ■ Select the unit: [▲] and [▼]. ■ Exit the configuration menu: [OK]. </td> </tr> </tbody> </table> <p>⊕ Once the flue gas measurement or ambient CO measurement is configured, the gas sensors are zeroed when the instrument is switched on (zeroing phase). The flue gas probe must be in the open air during the zeroing phase!</p>	Display/param.	Explanation	Fuel	Selecting the area version activates different calculation formulas and measurement parameters, see Area versions. <ul style="list-style-type: none"> ■ Select the fuel: [▲] and [▼]. ■ Switch to the next parameter: [→]. ■ Exit the configuration menu: [OK]. 	Unit of pressure	<ul style="list-style-type: none"> ■ Select the unit: [▲] and [▼]. ■ Switch to the next parameter: [→]. 	Unit of temperature	<ul style="list-style-type: none"> ■ Select the unit: [▲] and [▼]. ■ Exit the configuration menu: [OK].
Display/param.	Explanation										
Fuel	Selecting the area version activates different calculation formulas and measurement parameters, see Area versions. <ul style="list-style-type: none"> ■ Select the fuel: [▲] and [▼]. ■ Switch to the next parameter: [→]. ■ Exit the configuration menu: [OK]. 										
Unit of pressure	<ul style="list-style-type: none"> ■ Select the unit: [▲] and [▼]. ■ Switch to the next parameter: [→]. 										
Unit of temperature	<ul style="list-style-type: none"> ■ Select the unit: [▲] and [▼]. ■ Exit the configuration menu: [OK]. 										

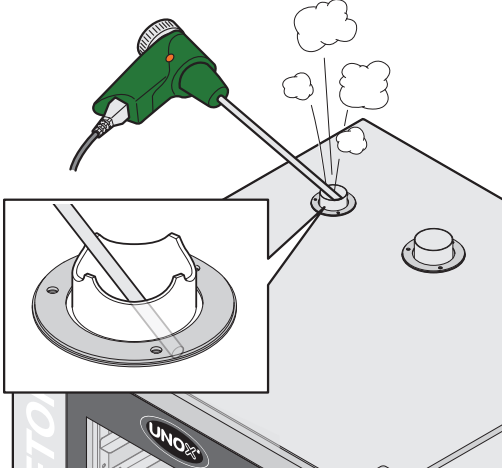
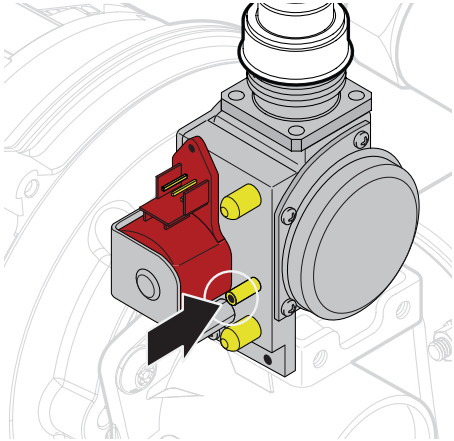
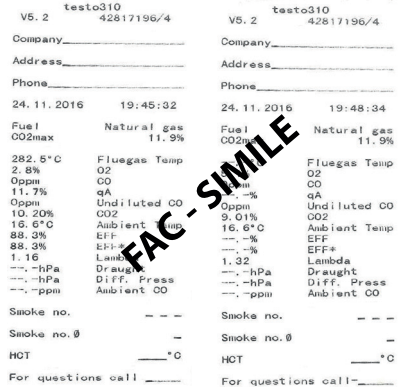
n° STEP	REQUIREMENT	TO DO LIST	ILLUSTRATION
7	Mandatory	Place the gas analyzer probe few centimeters inside the left chimney looking at the oven from the front (as shown in figure) and wait for the values to stabilize on the instrument display (do not insert the probe fully inside the chimney)	
8		<p>For an oven installed under a hood, follow the settings according to column A3 or B23 or European oven or the A3 column for US models.</p> <p>In case of an oven installed with the gas flow diverter XUC070 or XUC071 follow the settings according to column B13 for European or US ovens.</p> <p>When you open the gas valve cover pay attention to the gas valve cable harness. Check if it is properly connected.</p>	
9	If the emissions do NOT match the range reported on the UNOX technical chart in terms of CO and CO ₂	<p>If the emissions of CO₂ and CO are greater than the values reported on the UNOX technical chart, close the throttle gradually until the emissions meet the specified values (alove time to the system to react to the adjustment of the screw).</p> <p>If the emissions of CO₂ and CO are greater than the values reported on the UNOX technical chart, open the throttle gradually until the emissions meet the specified values (alove time to the system to react to the adjustment of the screw).</p>	
10	If the emissions match the range reported on the UNOX technical chart in terms of CO and CO ₂ .	Turn off the oven, print the receipt and leave a copy of the analysis to the customer.	

n° STEP	REQUIREMENT	TO DO LIST	ILLUSTRATION
11	<p>If the oven is one of the following</p> <ul style="list-style-type: none"> ■ XEVC-2021-GPX ■ XAVC-2021-GPX ■ XAVC-16FS-GPX 	<p>Repeat steps 5, 6, 7, 9 also for the second pre-mix group. After the setting of the second gas valve, recheck again the setting of the first one. If required, readjust gas valve 1 and rerun gas fumes test 2</p>	
12	Mandatory	<p>Perform the gas analysis test by choosing:</p> <p>GAS FUMES TEST 2</p>	<ul style="list-style-type: none"> - ① ② enter the service menu - ③ ④ type the PIN 99857 - ⑤ select UTILITIES - ⑥ select CALIBRATION - ⑦ select GAS 2 FUMES TEST. <p>oven will start at minimum blower speed</p> 
13	Mandatory	Proceed to STEP 6	
14	<p>If the emissions do NOT match the range reported on the UNOX technical chart in terms of CO and CO₂</p>	Proceed to STEP 7	

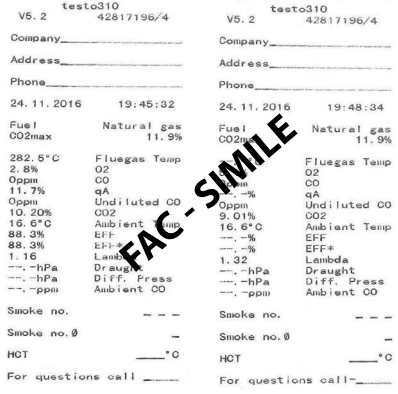
n° STEP	REQUIREMENT	TO DO LIST	ILLUSTRATION
15	If the emissions match the range reported on the UNOX technical chart in terms of CO and CO ₂ .	Turn off the oven, print the receipt and leave the customer a copy of the analysis results.	
16	If the throttle has been adjusted during "GAS FUMES TEST 2".	Repeat GAS FUMES TEST 1 and GAS FUME TEST 2	

Fault message guide

OVEN

AF01 – Motor thermal protection (permanent error)	132
AF02 - Safety thermostat alarm	135
AF03 - Temperature probes alarm	137
AF04 - Communication error with power board	140
AF23 - Gas alarm	143
AF24 - Wrong position of Pollo valve	147
AF25 - Trolley is missing	149
AF26 - Tank missing or safety thermostat	151
AF39 - Chamber ceiling temperature too high	153
AF41 - Case 1, T > 150 °C (302 °F)	156
AF41 - Case 2, T < 150 °C (302 °F)	157
AF43 - Single-point or multi-point core probe completely damaged	158
WF01 - WF02 Chamber temperature probe	159
WF04 - AFO8 Fan speed error	160
WF06 - Power board temperature warning	162
WF16 - Lack of water or EL1	164
WF17 - Partial breaking of multipoint probe	168
WF19 - Lack of detergent	170
WF20 - Rotor valve EG1	171
WF23 - Blower tachometer alarm	172
WF25 - Water valve EL2	174
WF26 - Rotor valve EG2	175
WF27 - Lack of water or valve EL1	176
WF29 - Gas fumes temperature	177
WF30 - Gas fumes probe board communication error	178
WF31 - Fumes board temperature	179
WF33/AF40 - (only in gas ovens) Corrupted Sd Card	181
WF34 EG1 or EL2 valve	182
WF35 EG1 or EG2 or EL2 valve	183
WF36 lack of water or EL1 or EG1/EG2	184
WF37 - Lack of water or EL1 or EG1/EG2	185
WF38 - Flame control board warning	186
WF41 - Internet connection failure	187

ACCESSOIRES

HOOD

WC01 – Temperature probe warning	188
WC02 – Power board over temperature	190
WC05 – Fumes temperature warning	191
WC06 – Lack of power warning	192
WC07 – Lack of communication warning	193

STATIC OVEN

AS01-AS02- Floor or ceiling safety thermostat alarm	194
AS03 - Lack of communication alarm	195
AS04-AS05 - Floor/ceiling temperature probe alarm	196
WS01 - Power board over heating warning	197

PROVER

AL01-AL04 - Chamber/resistor temperature probe alarm	198
AL02 - Lack of communication alarm	199
AL03 - Lack of power alarm	200
WL01 - Humidity probe alarm	201
WL02 - Power board over temperature alarm	202

SLOWTOP

AM01 - Chamber temperature probe alarm	203
AM02 - Lack of communication	204
AM03 - Safety thermostat alarm	205
AM04 - Motor thermal protection alarm (T > 150 °C/302 °F)	206
WM02 - Power board over heating warning	207
WM03 - Core probe warning	208

AUTO-DIAGNOSTIC MESSAGES

Alarm or Warning messages regarding the oven or installed peripherals accessories are all displayed to the control panel.

Warning messages are signal malfunctions that nevertheless allow the appliance and peripherals accessories to operate, through a restricted set of functions. The "OK" icon on the screen clears all warning listed to the control panel.

Alarm messages identify situations that fail to allow any appliance/peripheral accessories operation whatsoever, and therefore must be put in STOP mode. If the alarm messages strictly refer to the peripherals accessories, the oven can still be used.

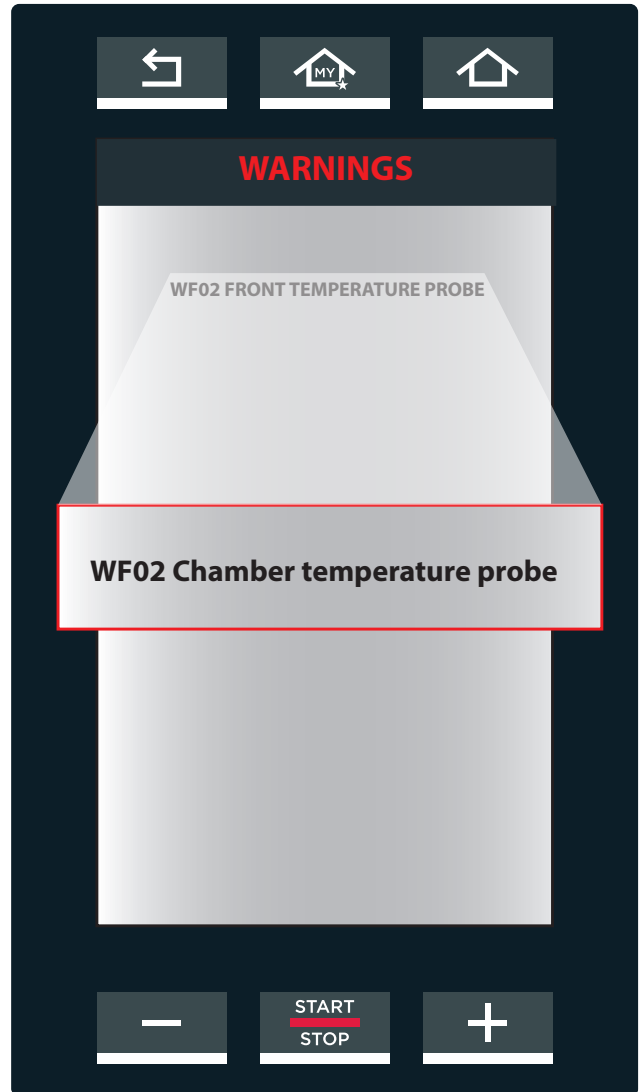
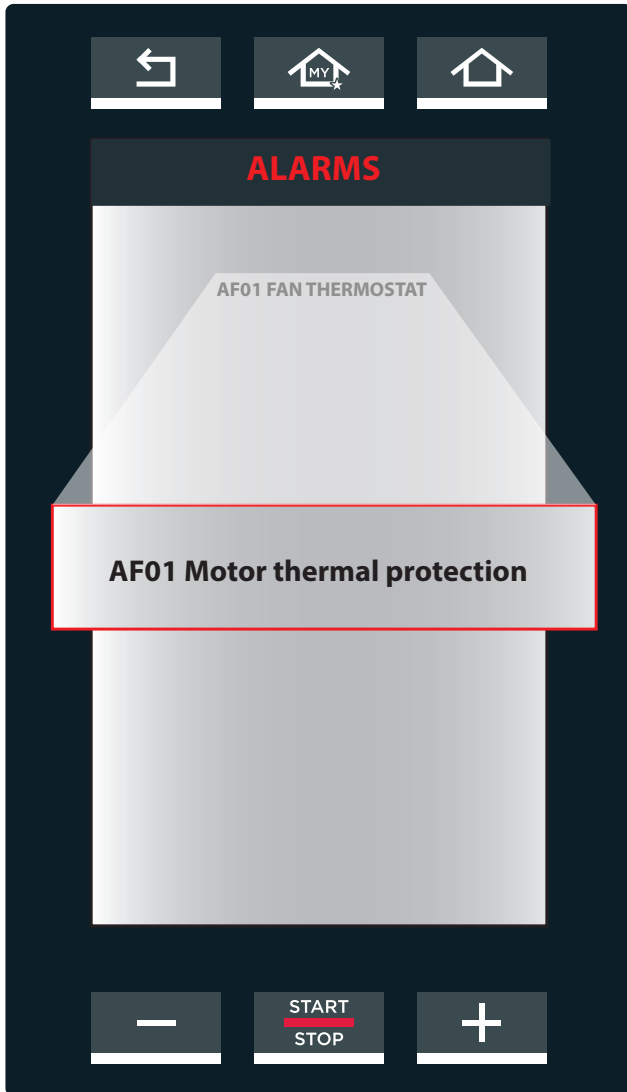

AF01 – MOTOR THERMAL PROTECTION (PERMANENT ERROR)

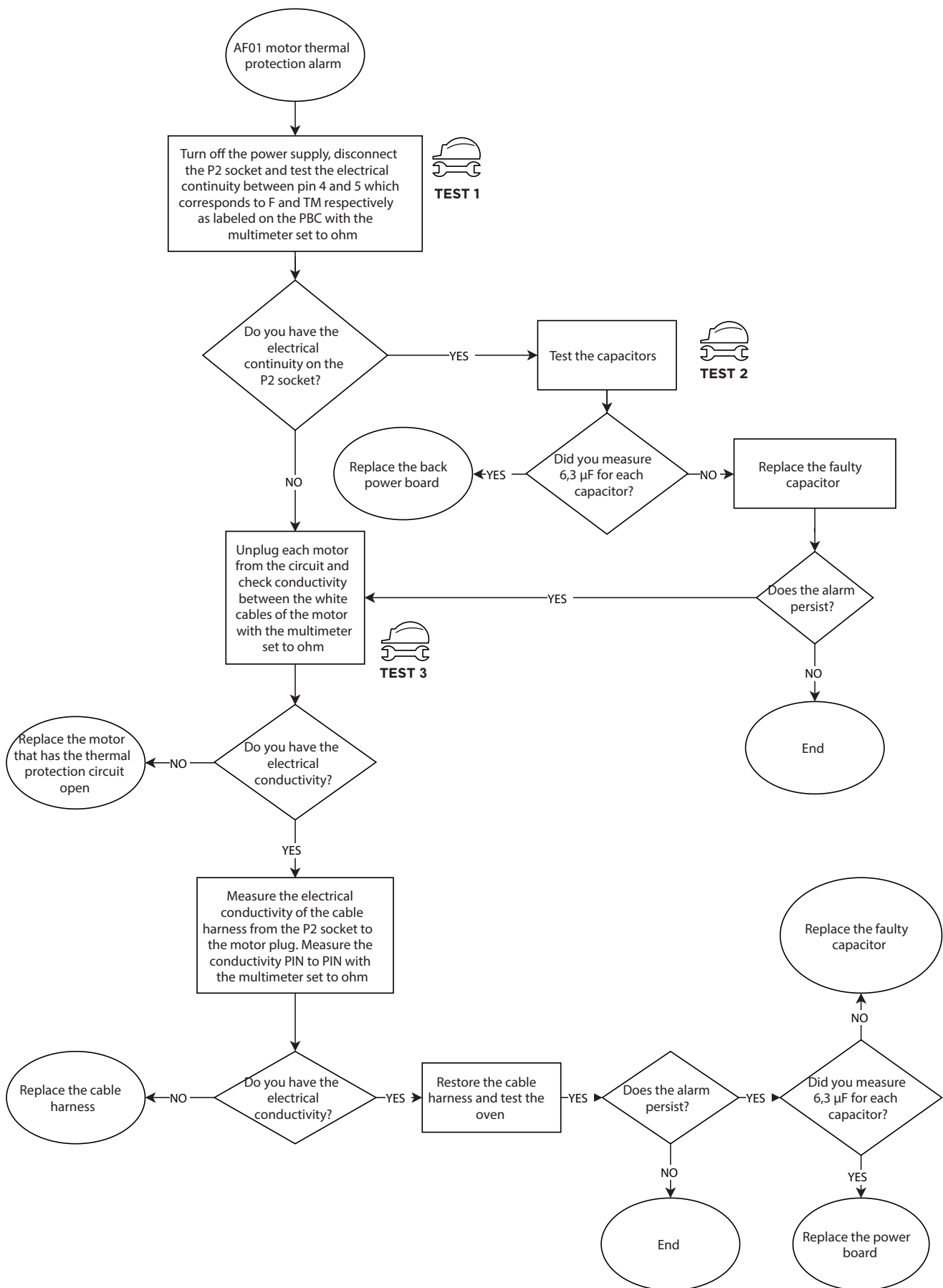



Test to do

Test 1 Motor thermal protection test

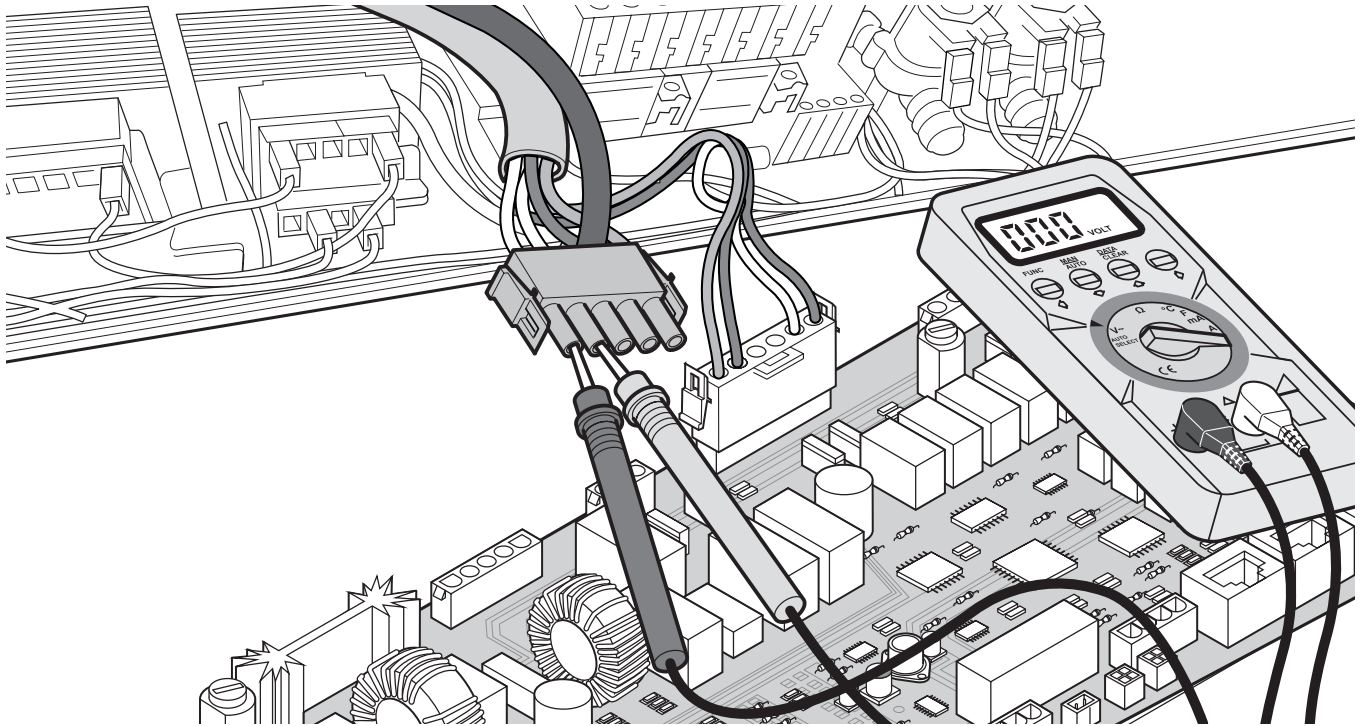

Test 2 Power board optocoupler check - Check if the yellow octocoupler on the powerboard, is connecting to right and left depending the direction of the motor

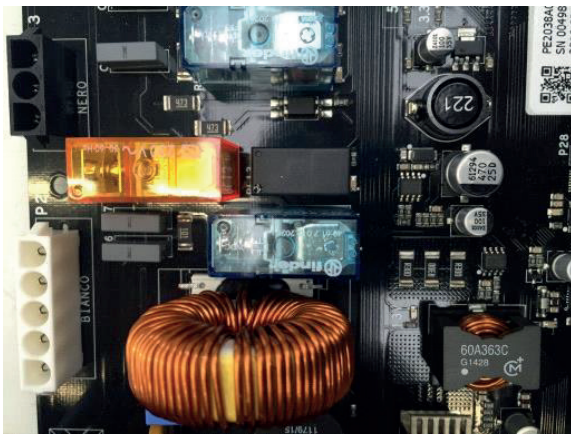

PE2038

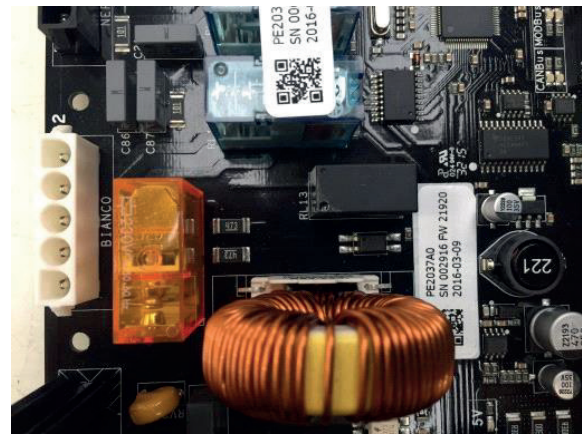

PE2037

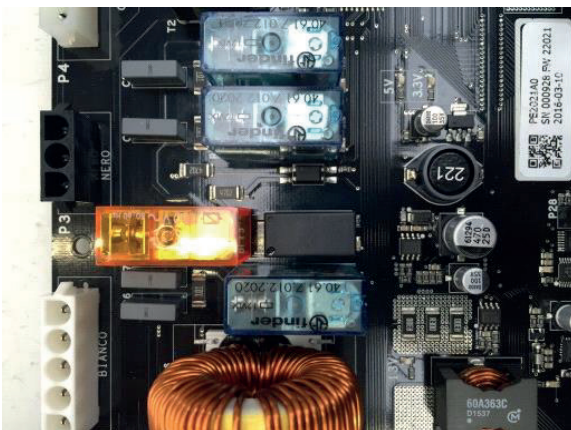

PE2021

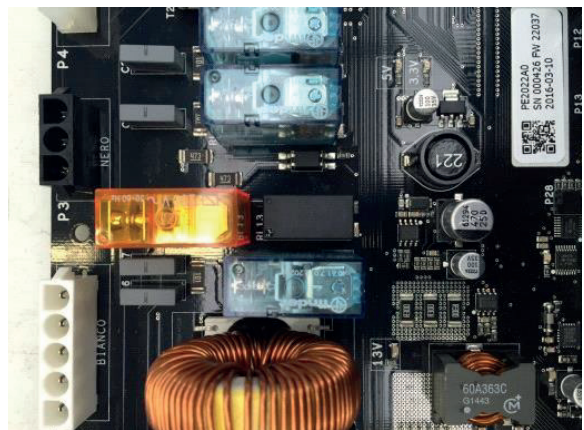

PE2022

Figure 3 Test

Other visual checks:

- 1) Cooling fan is running
- 2) Motors stuck by the shaft
- 3) External heat source



AF02 - SAFETY THERMOSTAT ALARM

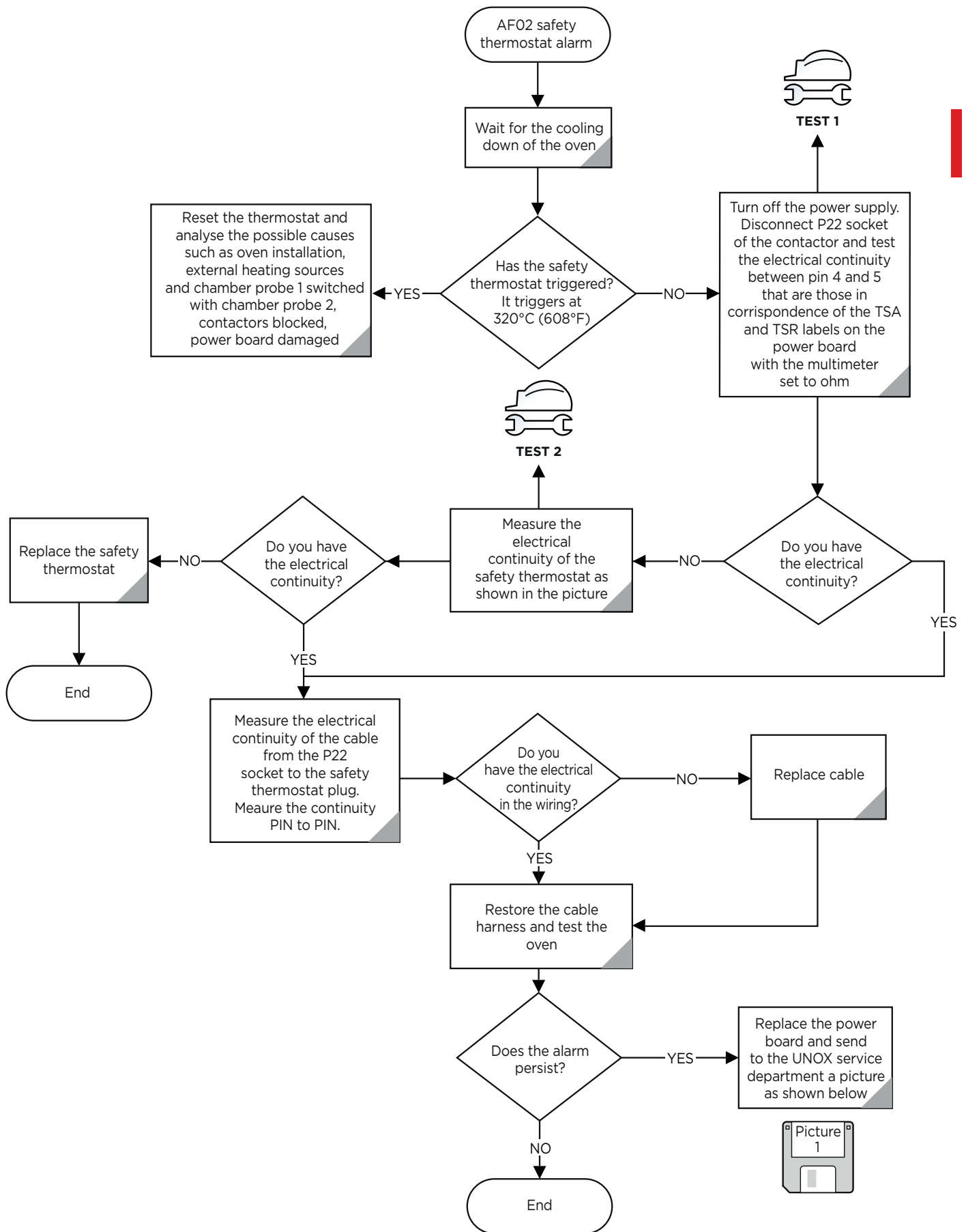



Test to do

Check the contactors are stuck closed. Feeding the heating elements constantly.

Test 1

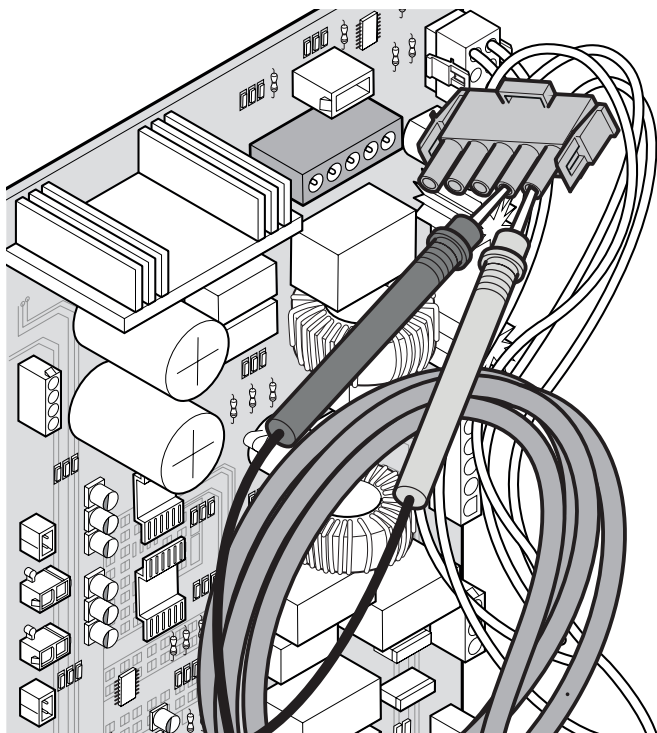

Test 2

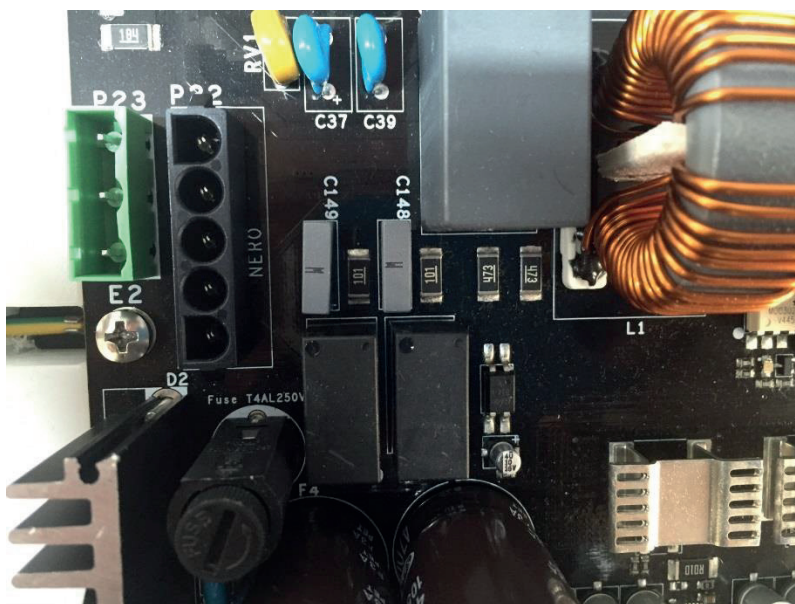
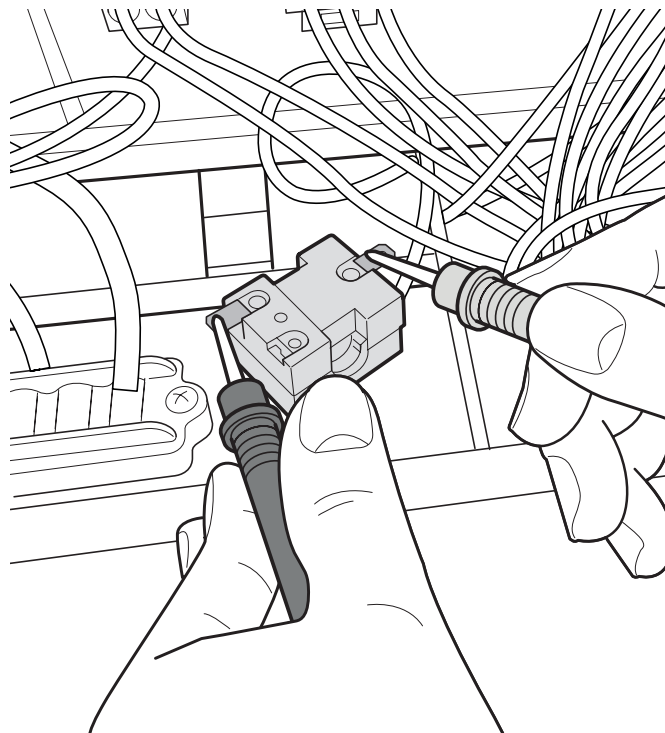

AF03 - TEMPERATURE PROBES ALARM

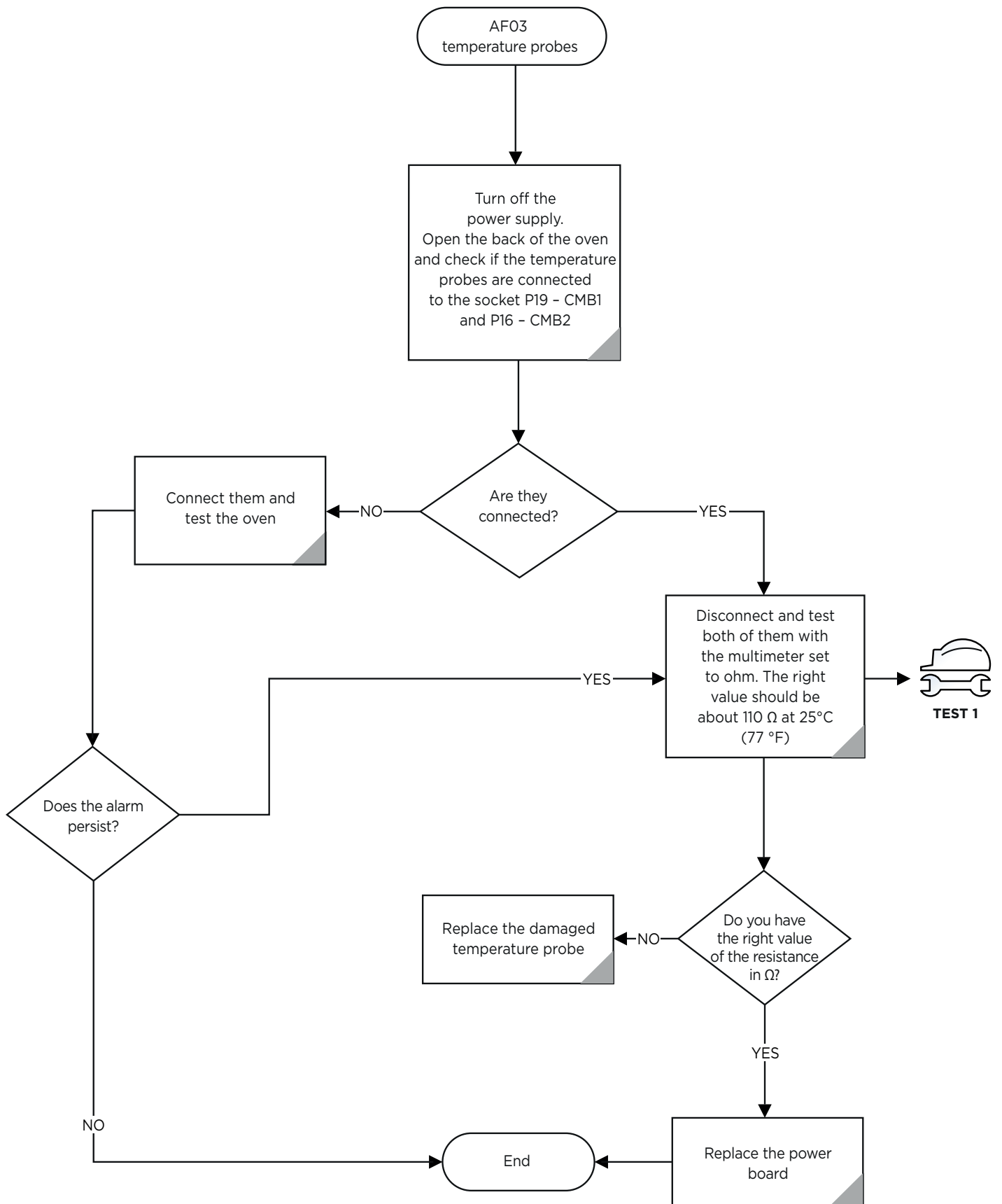



Test to do

Test 1

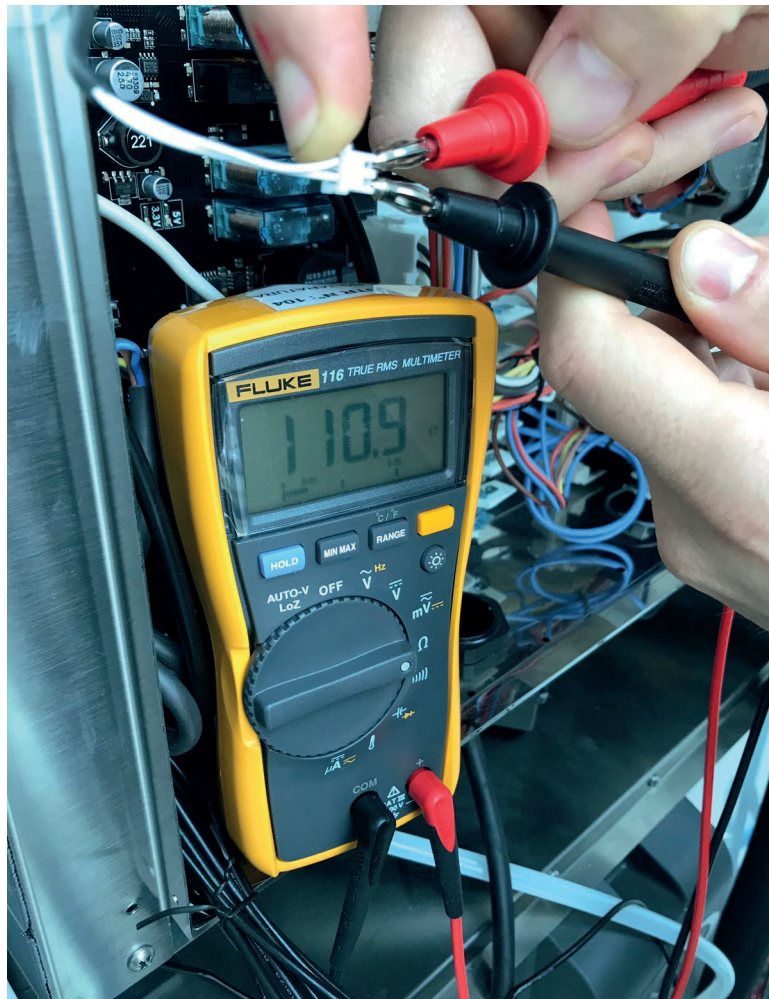
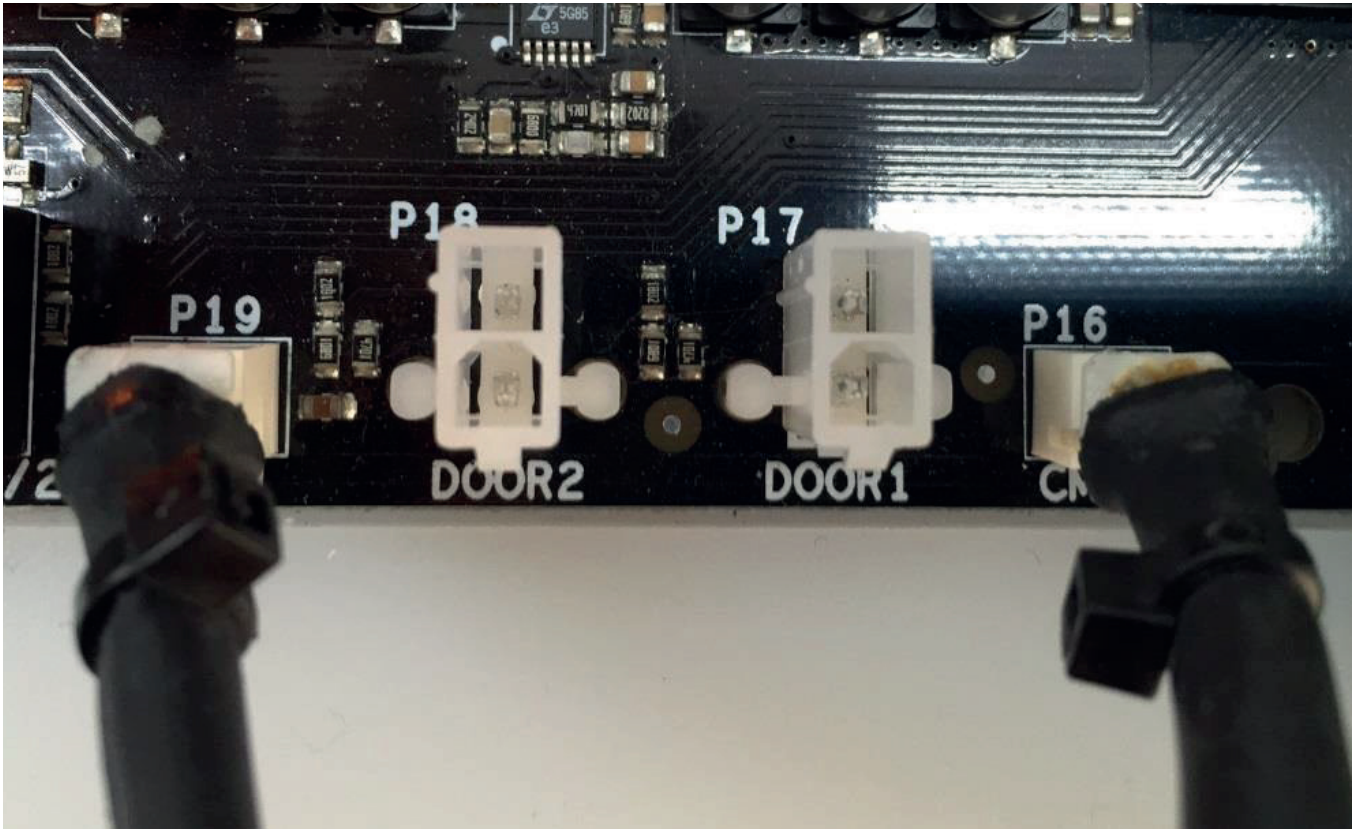

Pt100 Temperature Probe Resistance table

°C	0	1	2	3	4	5	6	7	8	9
10	103.9	104.29	104.68	105.07	105.46	105.85	106.24	106.63	107.02	107.4
20	107.79	108.18	108.57	108.96	109.35	109.73	110.12	110.51	110.9	111.28
30	111.67	112.06	112.45	112.83	113.22	113.61	113.99	114.38	114.77	115.15
40	115.54	115.93	116.31	116.7	117.08	117.47	117.85	118.24	118.62	119.01
50	119.4	119.78	120.16	120.55	120.93	121.32	121.7	122.09	122.47	122.86
60	123.24	123.62	124.01	124.39	124.77	125.16	125.54	125.92	126.31	126.69
70	127.07	127.45	127.84	128.22	128.6	128.98	129.37	129.75	130.13	130.51
80	130.89	131.27	131.66	132.04	132.42	132.8	133.18	133.56	133.94	134.32
90	134.7	135.08	135.46	135.84	136.22	136.6	136.98	137.36	137.74	138.12
100	138.5	138.88	139.26	139.64	140.02	140.39	140.77	141.15	141.53	141.91
110	142.29	142.66	143.04	143.42	143.8	144.17	144.55	144.93	145.31	145.68
120	146.06	146.44	146.81	147.19	147.57	147.94	148.32	148.7	149.07	149.45
130	149.82	150.2	150.57	150.95	151.33	151.7	152.08	152.45	152.83	153.2
140	153.58	153.95	154.32	154.7	155.07	155.45	155.82	156.19	156.57	156.94
150	157.31	157.69	158.06	158.43	158.81	159.18	159.55	159.93	160.3	160.67
160	161.04	161.42	161.79	162.16	162.53	162.9	163.27	163.65	164.02	164.39
170	164.76	165.13	165.5	165.87	166.24	166.61	166.98	167.35	167.72	168.09
180	168.46	168.83	169.2	169.57	169.94	170.31	170.68	171.05	171.42	171.79
190	172.16	172.53	172.9	173.26	173.63	174	174.37	174.74	175.1	175.47
200	175.84	176.21	176.57	176.94	177.31	177.68	178.04	178.41	178.78	179.14
210	179.51	179.88	180.24	180.61	180.97	181.34	181.71	182.07	182.44	182.8
220	183.17	183.53	183.9	184.26	184.63	184.99	185.36	185.72	186.09	186.45
230	186.82	187.18	187.54	187.91	188.27	188.63	189	189.36	189.72	190.09
240	190.45	190.81	191.18	191.54	191.9	192.26	192.63	192.99	193.35	193.71
250	194.07	194.44	194.8	195.16	195.52	195.88	196.24	196.6	196.96	197.33
260	197.69	198.05	198.41	198.77	199.13	199.49	199.85	200.21	200.57	200.93

AF04 - POWER BOARD COMMUNICATION ERROR

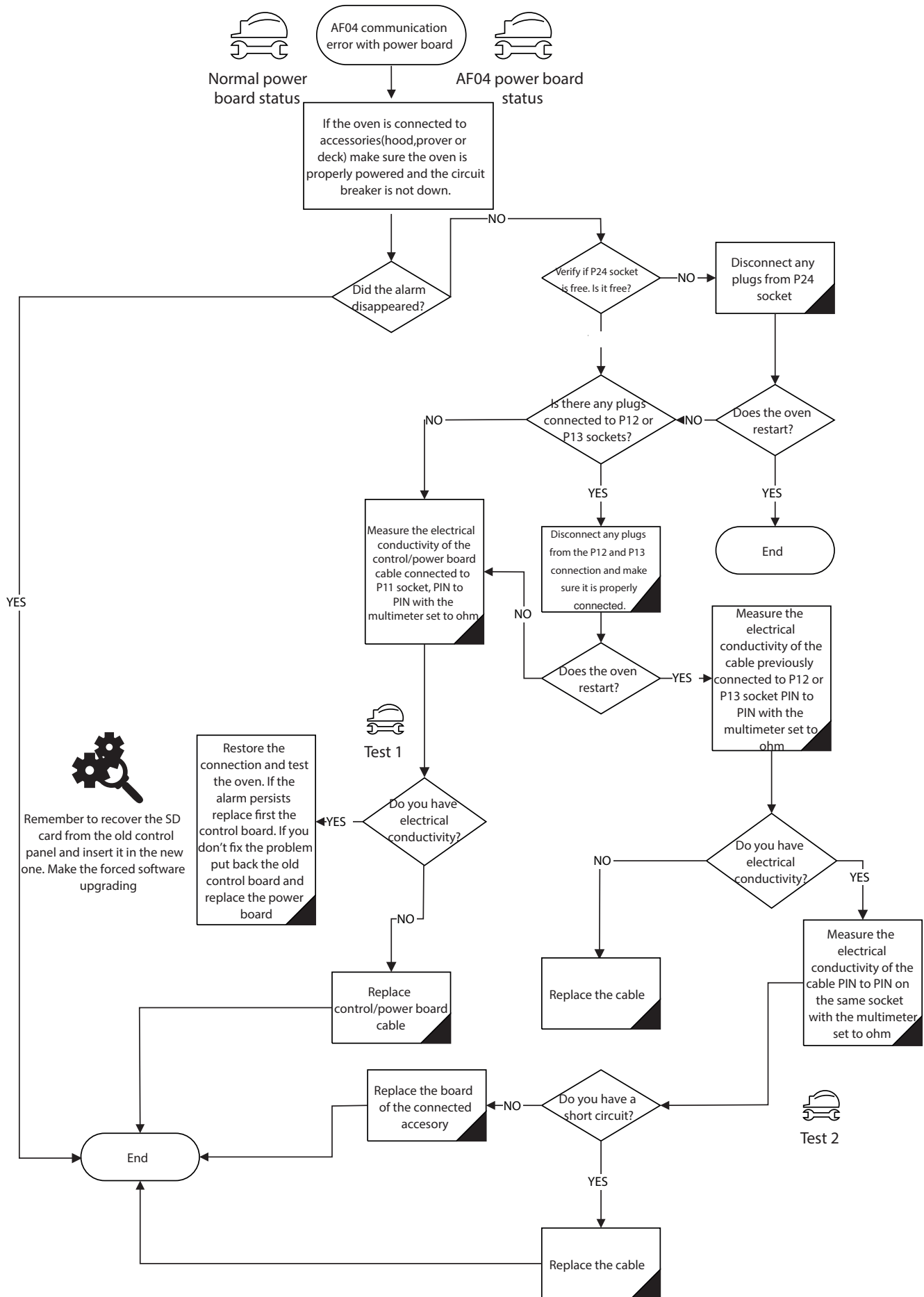

 Test to do

Normal power board status

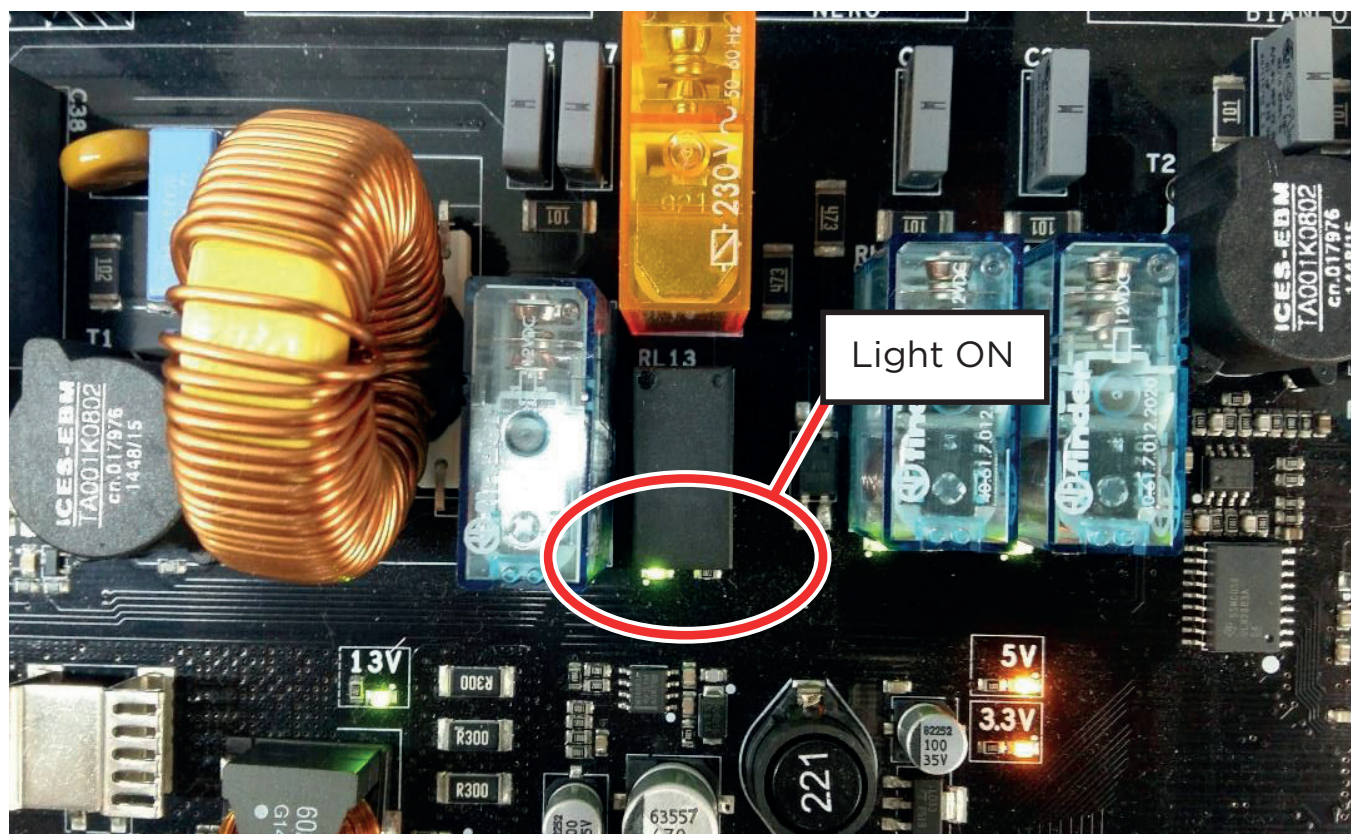

AF04 power board status

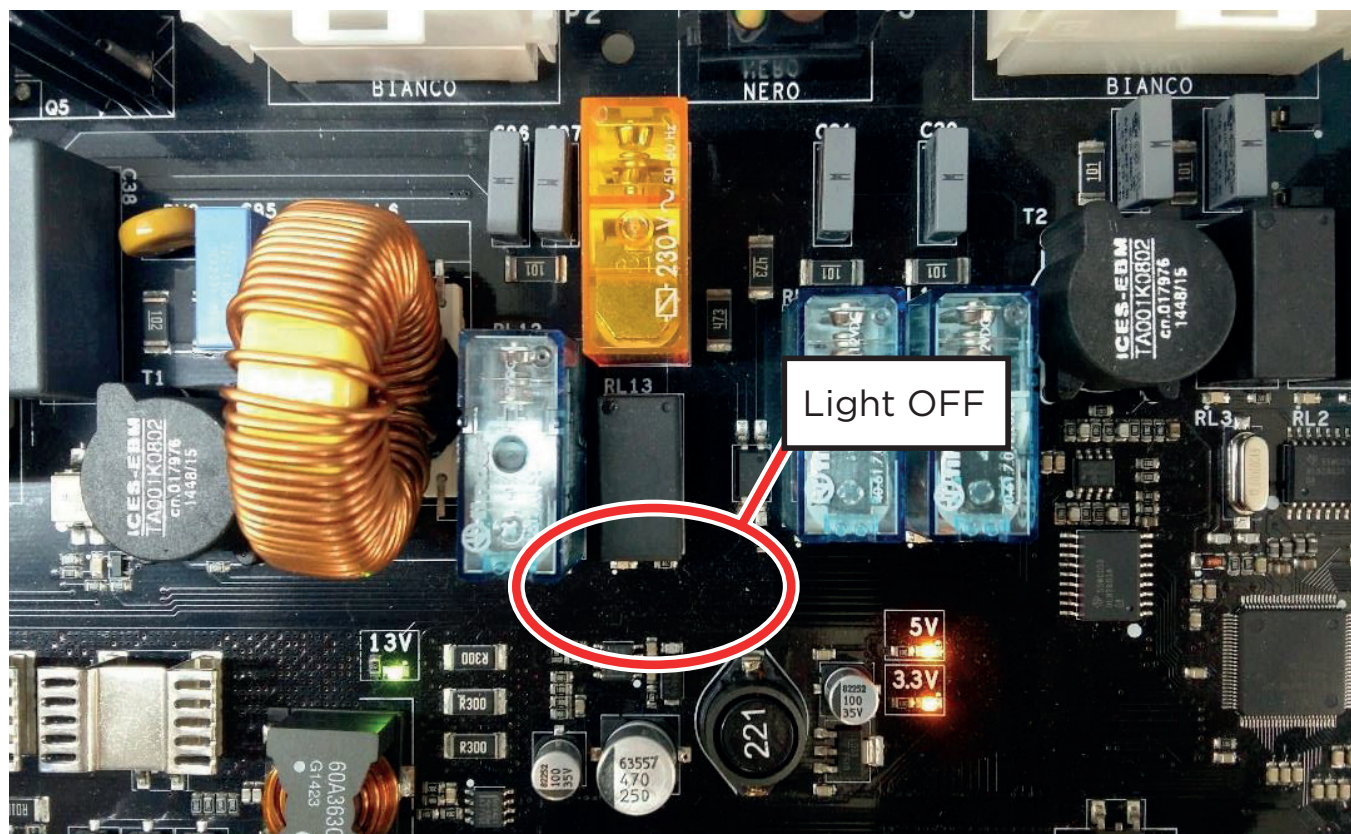

Test 1 Measure the electrical conductivity of the control/power board cable connected to P11 socket on Powerboard, PIN to PIN.

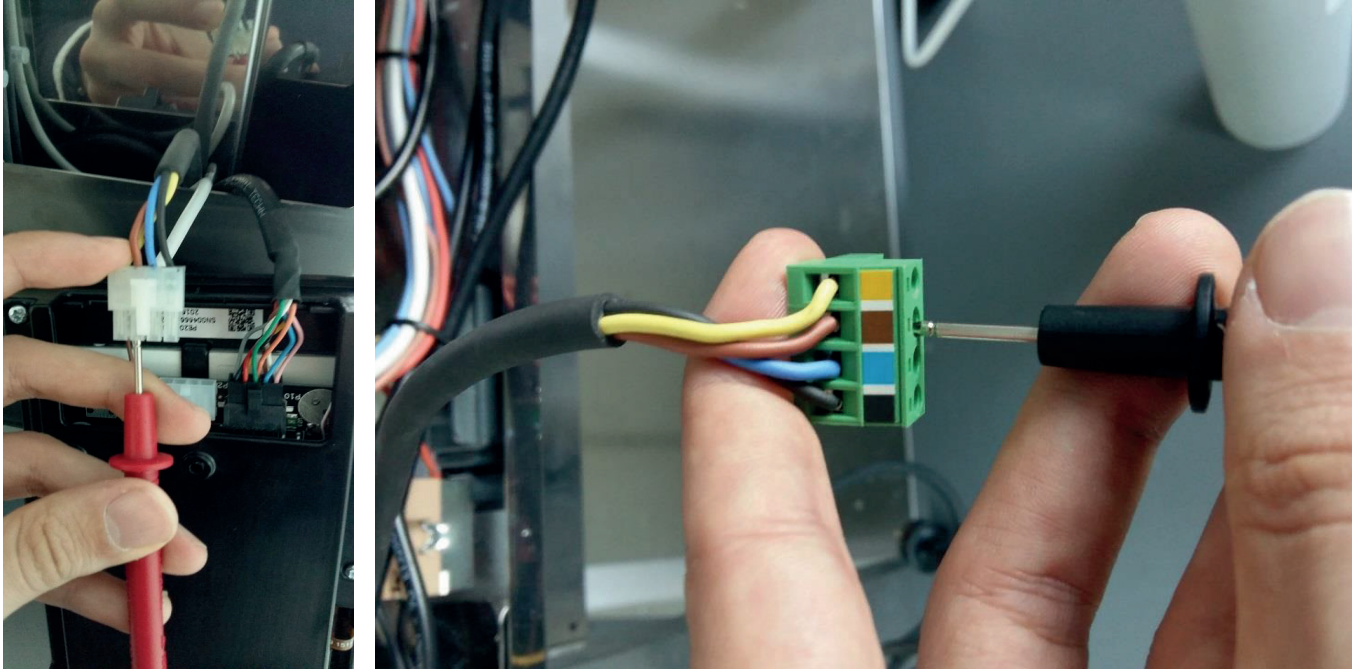

Test 2 Measure the electrical conductivity of accessory canbus cable

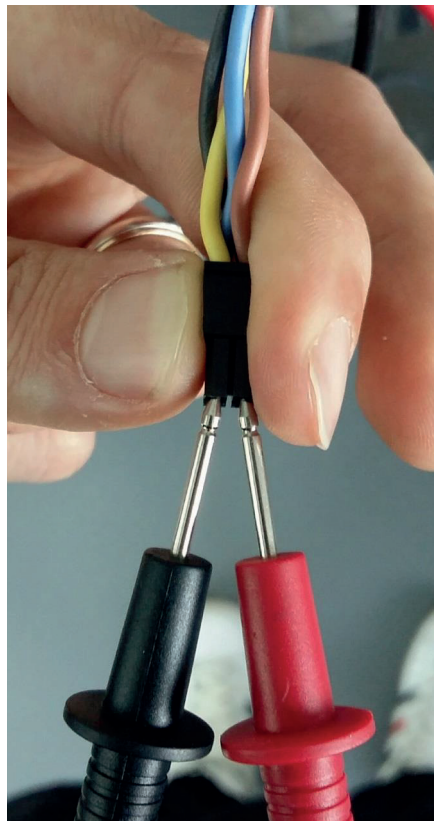

AF23 - GAS ALARM

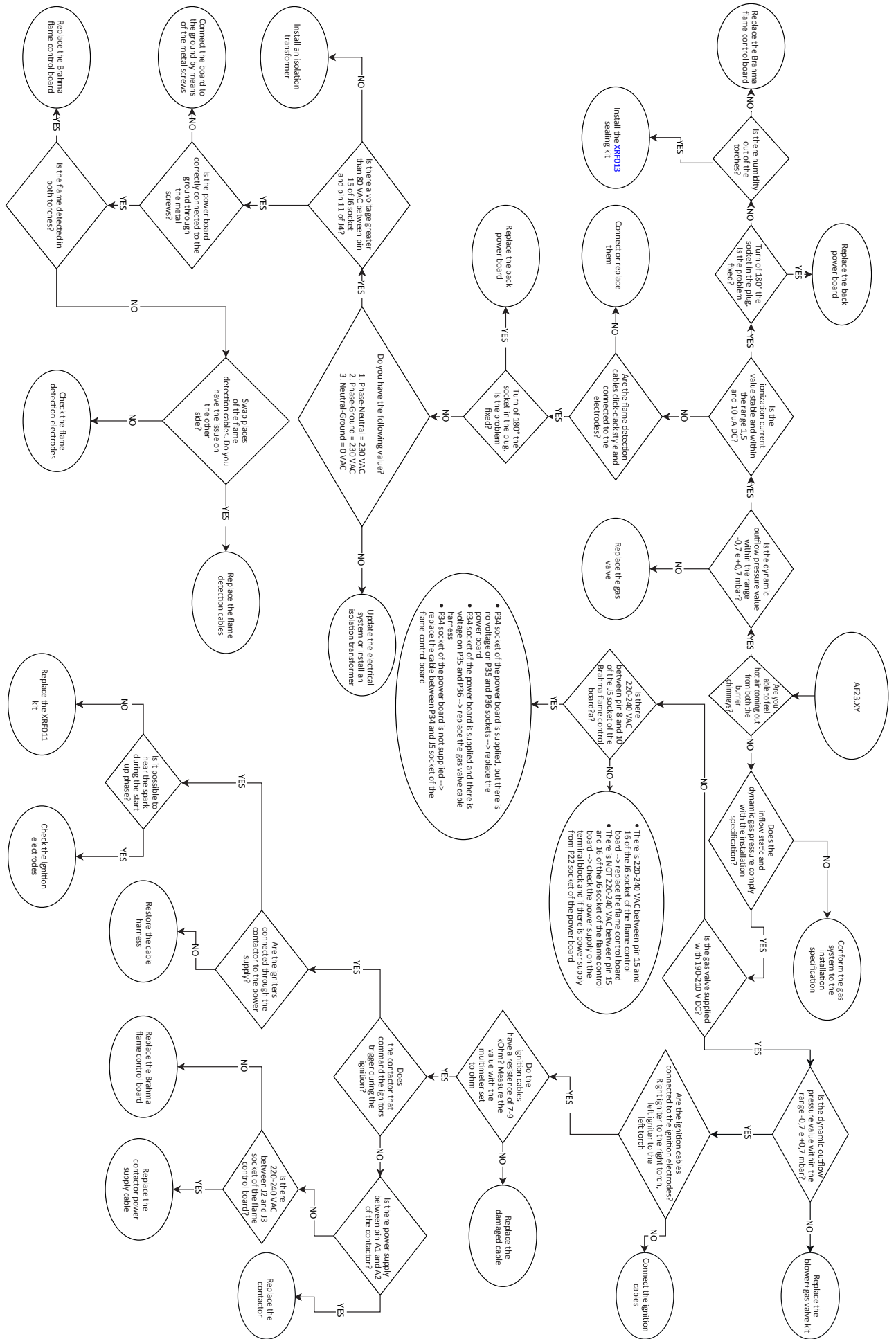



Test to do

Test 1

Measure the ionization current with the multimeter set to microamp DC current placed in series between the flame detection electrode and the cable harness (see **Figure 23** and **Figure 25**)

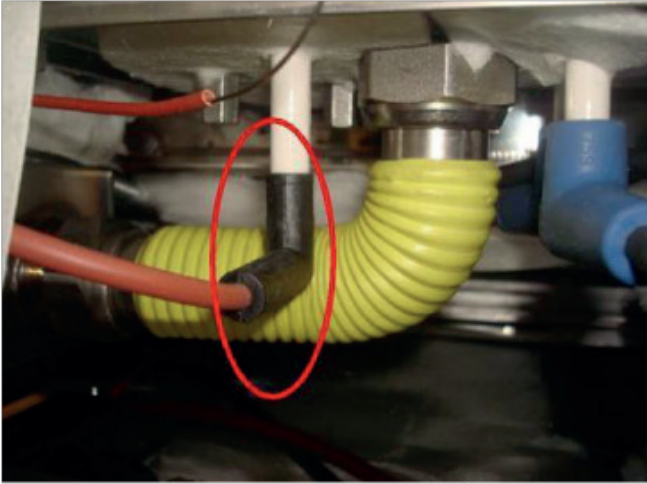

Figure 23

How to remove the flame detection cable

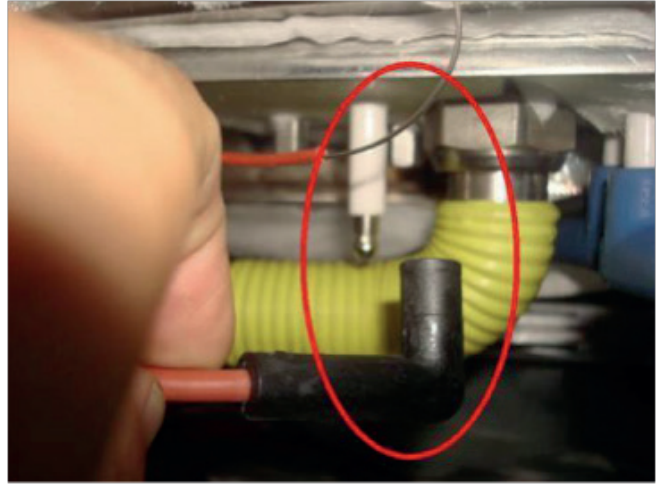

Figure 25

How to connect the multimeter in series between the flame detection cable and the flame detection electrode



Test 2

Measure the voltage out of the J5 socket of the flame control board between PIN 8 and PIN 10 using the multimeter set to VAC. Measure the voltage on the P34-35 -36 sockets of the power board using the multimeter set to VAC. (see **Figure 24** and **Figure 26**)

Figure 24

How to measure the power supply to the P34 socket of the power board

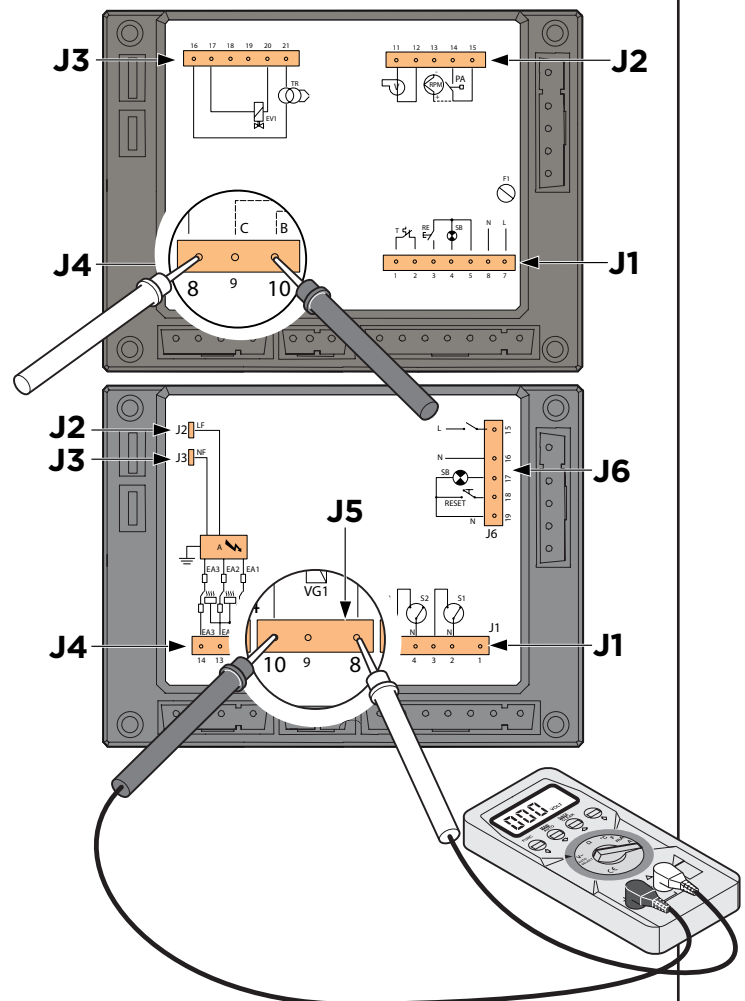



Test to do

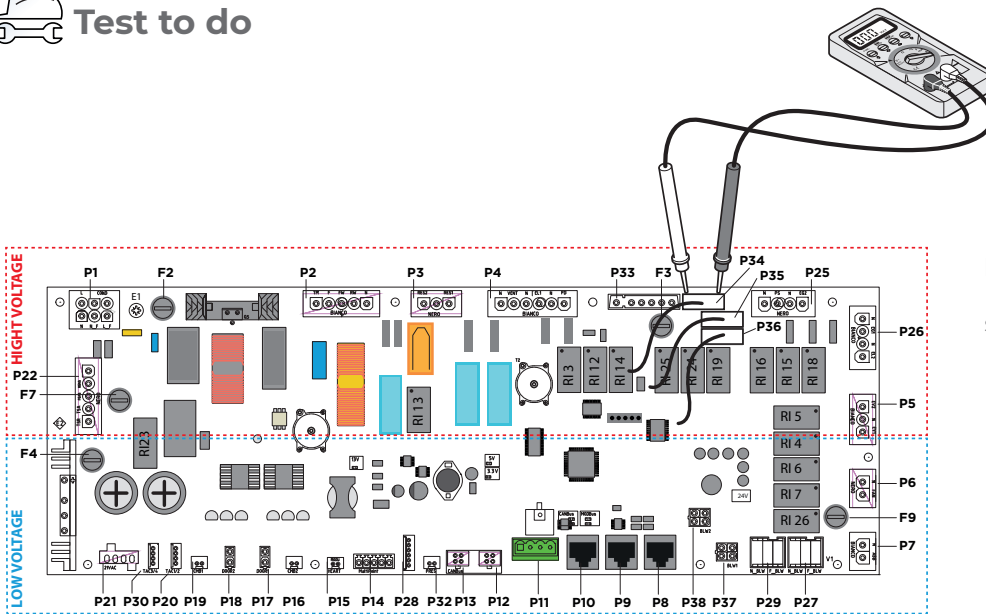

Figure 26

How to measure the power supply from the flame control board to the P34 socket of the power board and from the P35 or P36 to the gas valve

Test 3

Measure the outflow gas pressure with a differential pressure gauge. Take the measurement on the lower screw of the gas valve. When the valve is opened, check if it is supplied with 190 – 210 VDC. As an alternative you can check if the relay EV_GAS is ON (it is near the RL24 relay next to the P33 socket), **Figure 27**

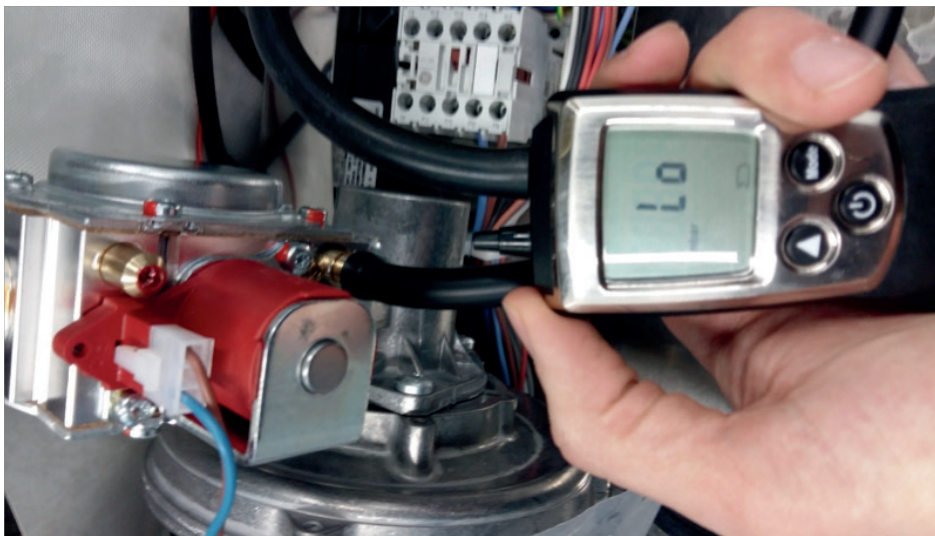

Figure 27

How to measure the outflow gas pressure

Test 4

Measure the voltage on J6 socket of the flame control board between pin 15 and 16 with the multimeter set to VAC (see **Figure 247**)



Test to do

Test 5

Remove the burner and check the following:

Check the gap between the ignition and flame detection electrodes (see **Figure 28**) and (see **Figure 29**).

Test the electrical continuity of the electrodes with the multimeter set to ohm.

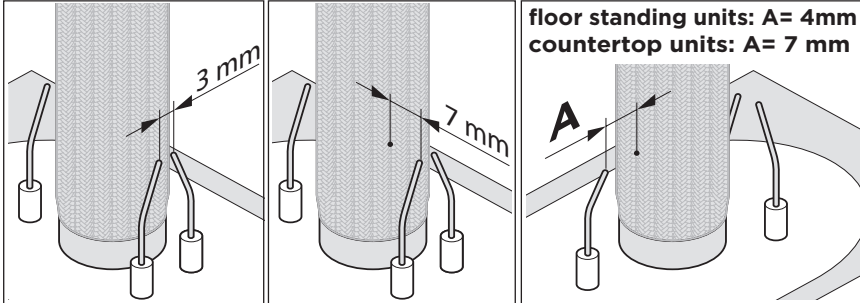

Figure 28

Proper position of the electrodes



Figure 29

How to set the proper positioning of the electrodes

AF24 - WRONG POSITION OF THE POLLO VALVE

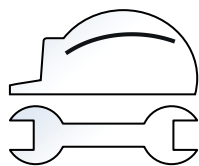
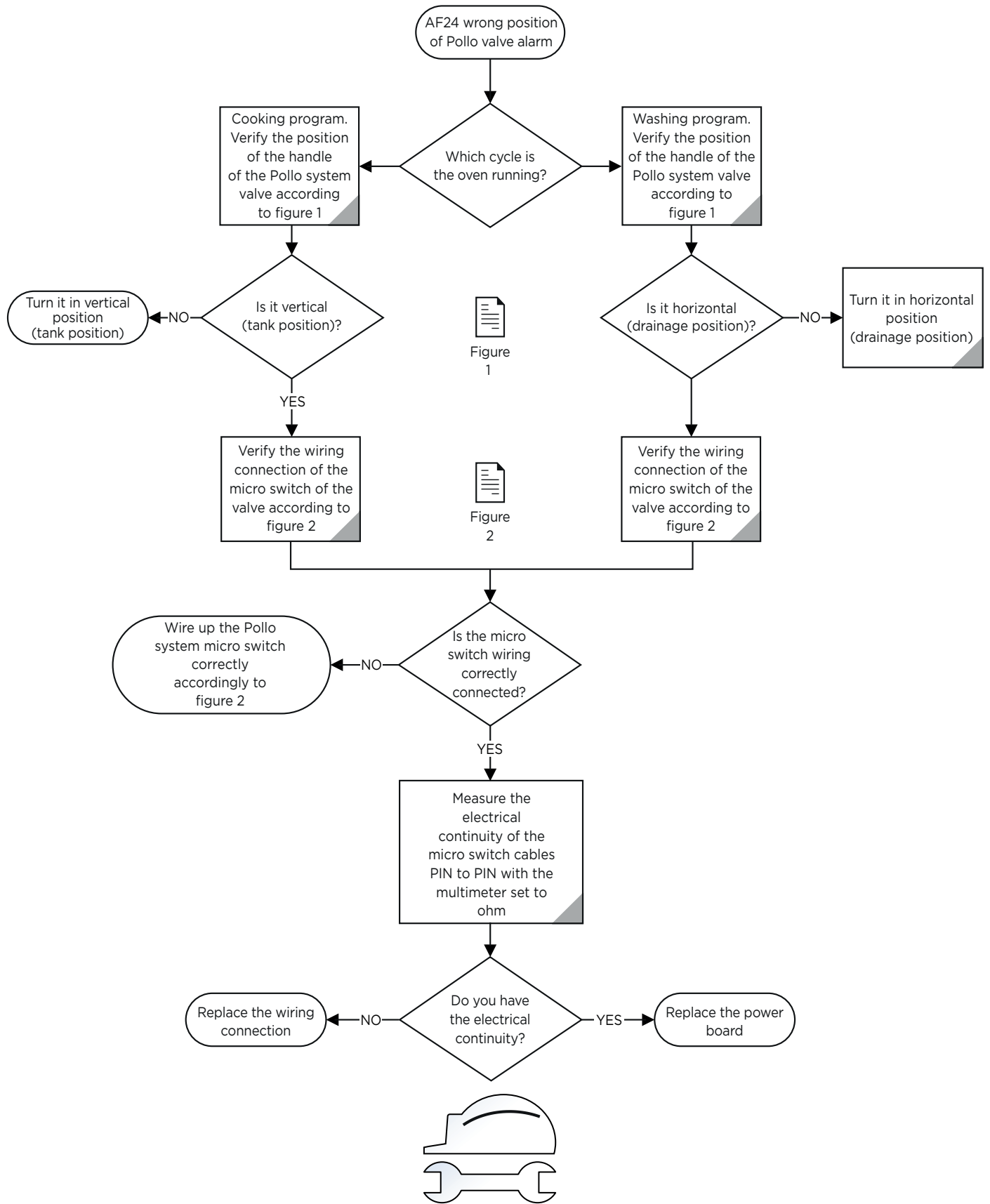

In case of trace of water or detergent in the micro switch connector check and in case replace the Pollo valve gasket GN1587A0 and replace the micro switch

Test to do

Figure 1

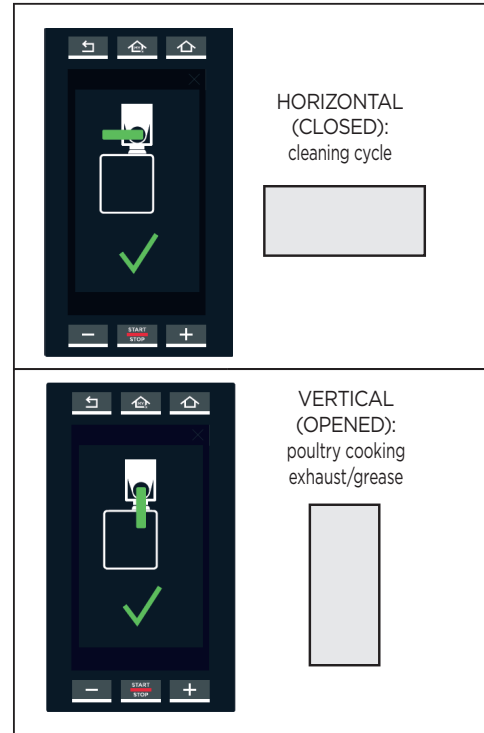
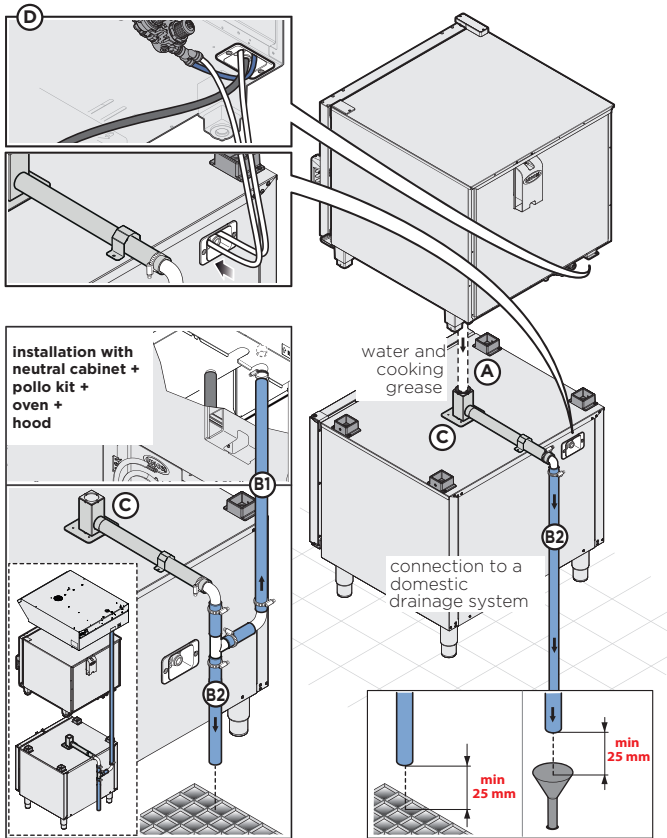
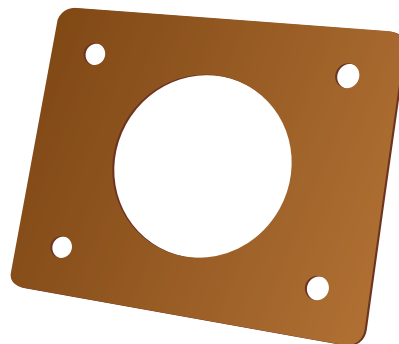
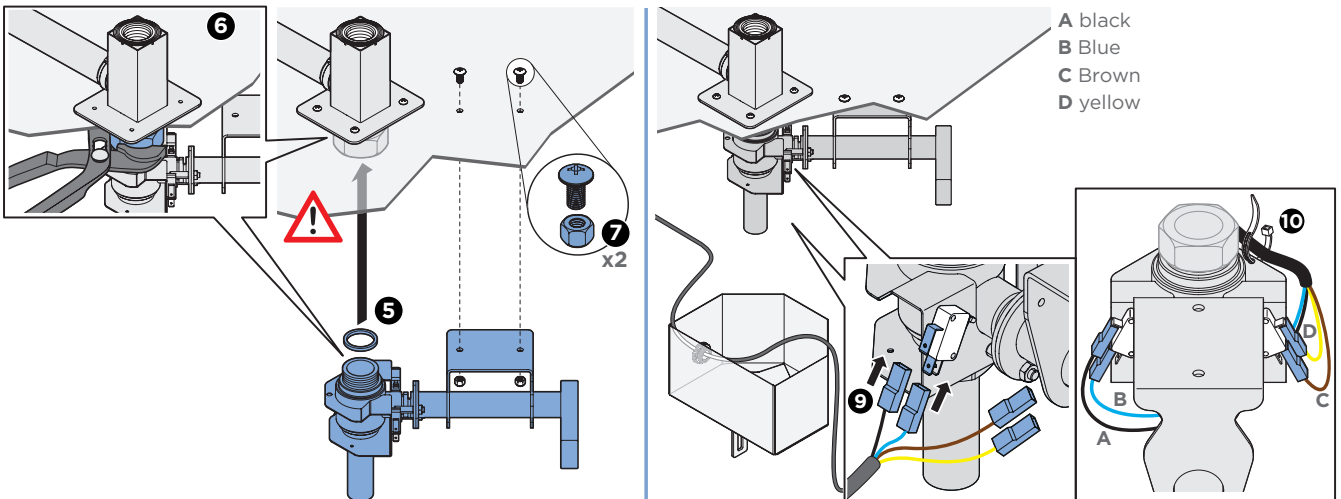
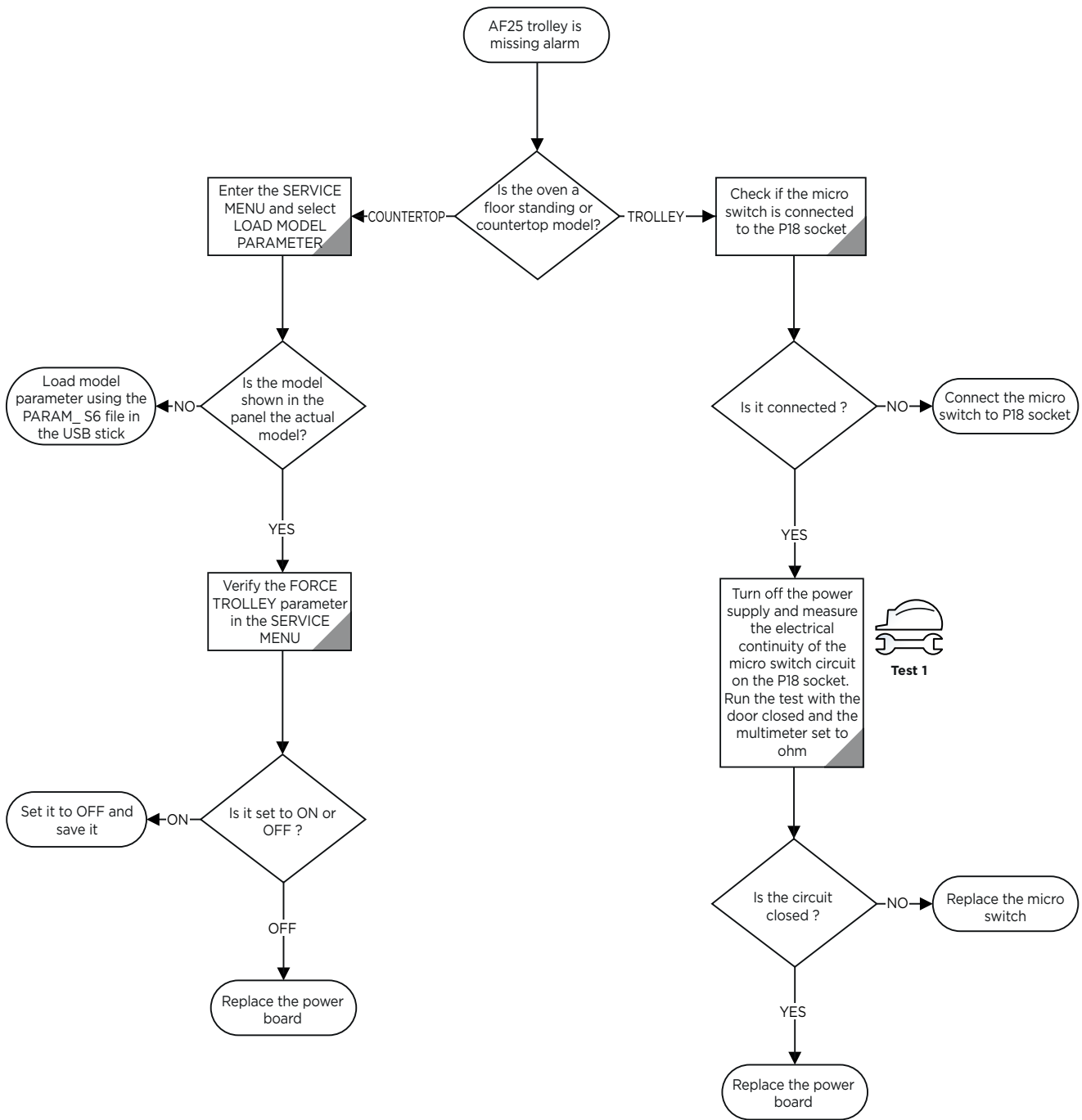

Figure 2



AF25 - TROLLEY IS MISSING





Test to do

Test 1 Measure the electrical conductivity of the micro switch

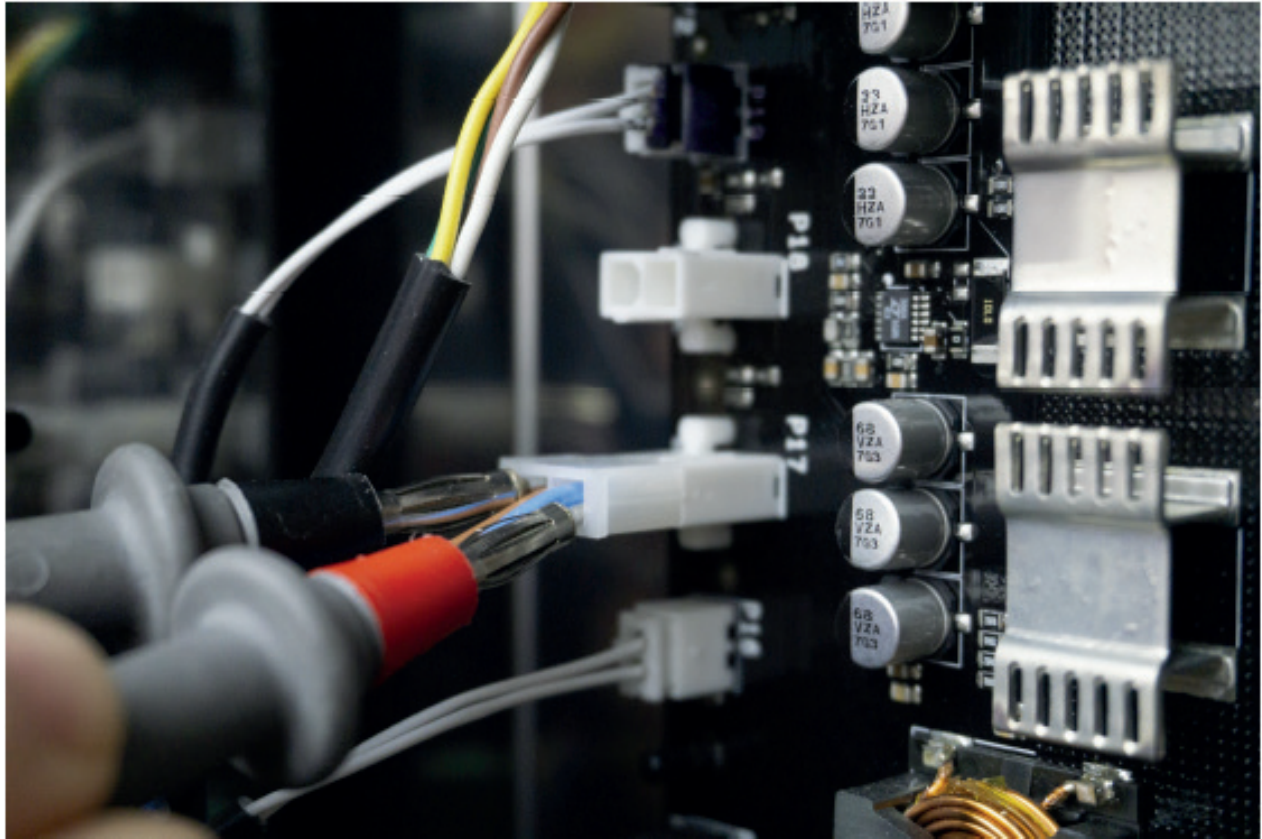

AF26 - TANK MISSING OR SAFETY THERMOSTAT

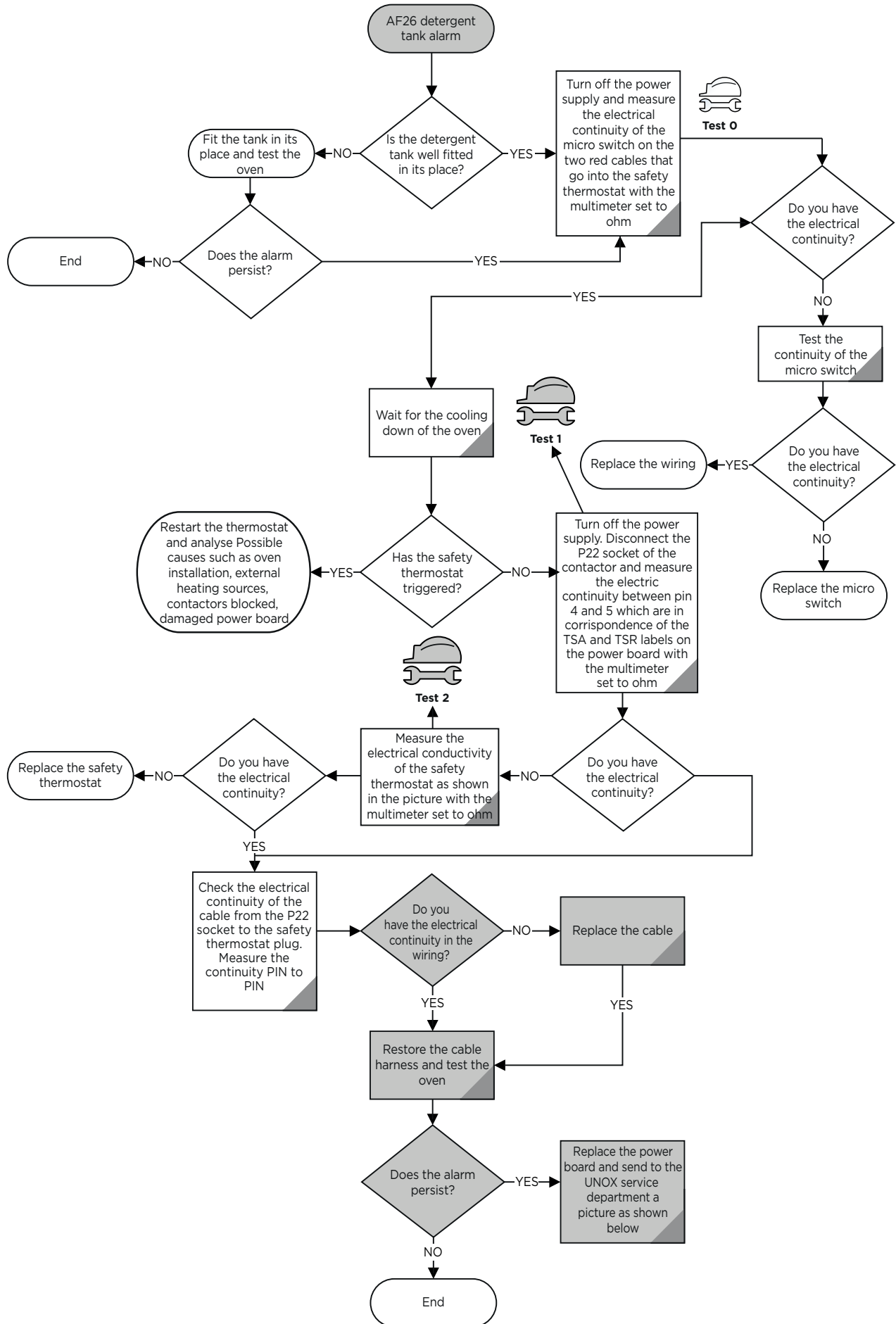

Test to do

Test 1 Measure the electrical conductivity of the micro switch

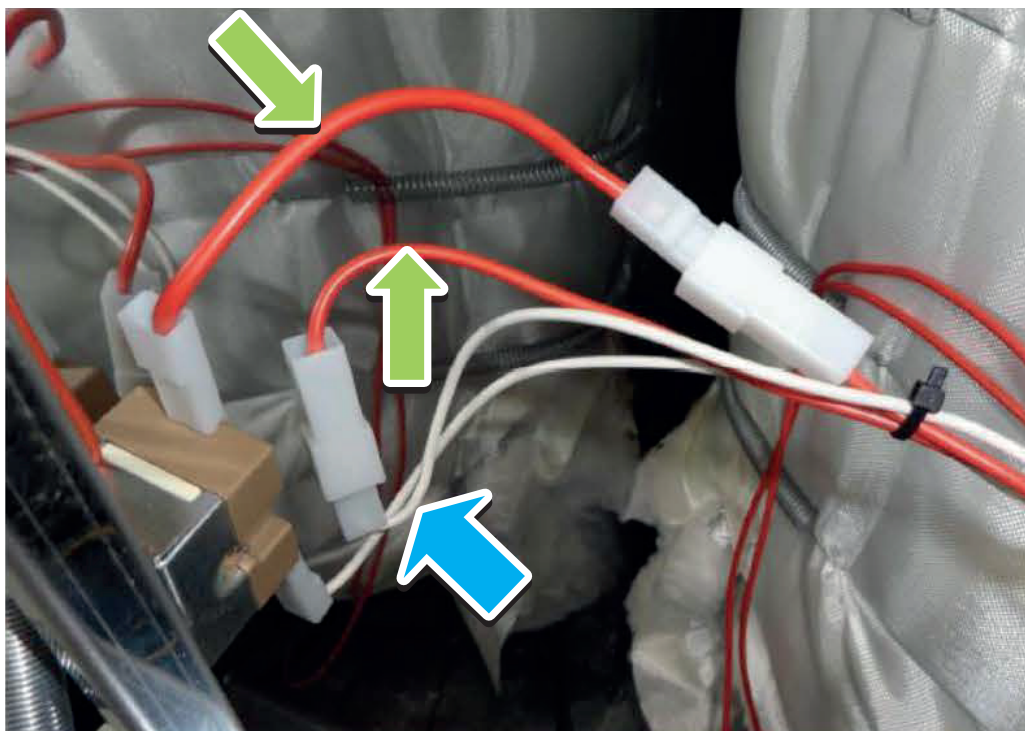

Test 2 The electrical continuity on P22 socket between the pin 4 and the pin 5 are in corresponding to the TSA and TSR

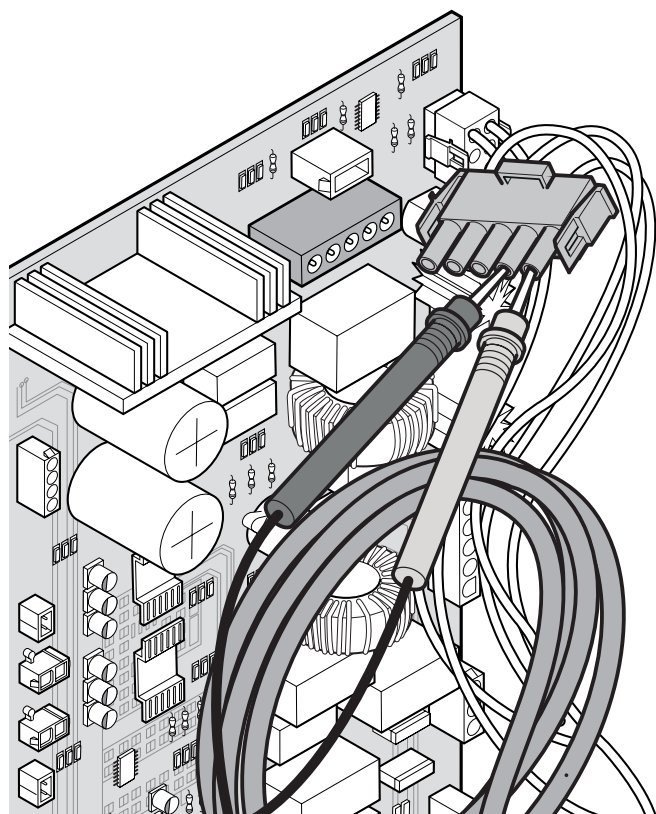

Test 3 Measure electrical conductivity of the safety thermostat

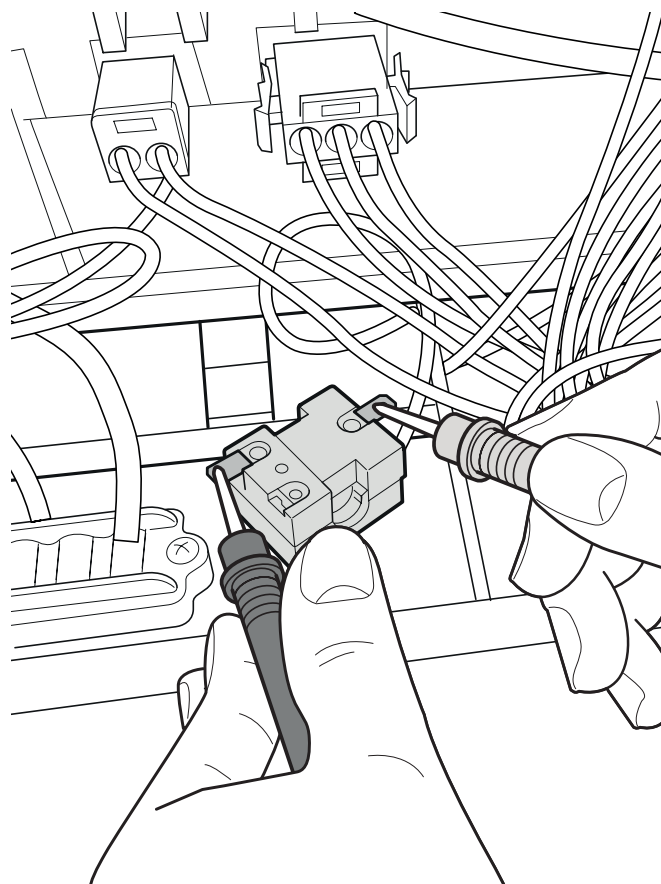

AF39 - CHAMBER CEILING TEMPERATURE TOO HIGH

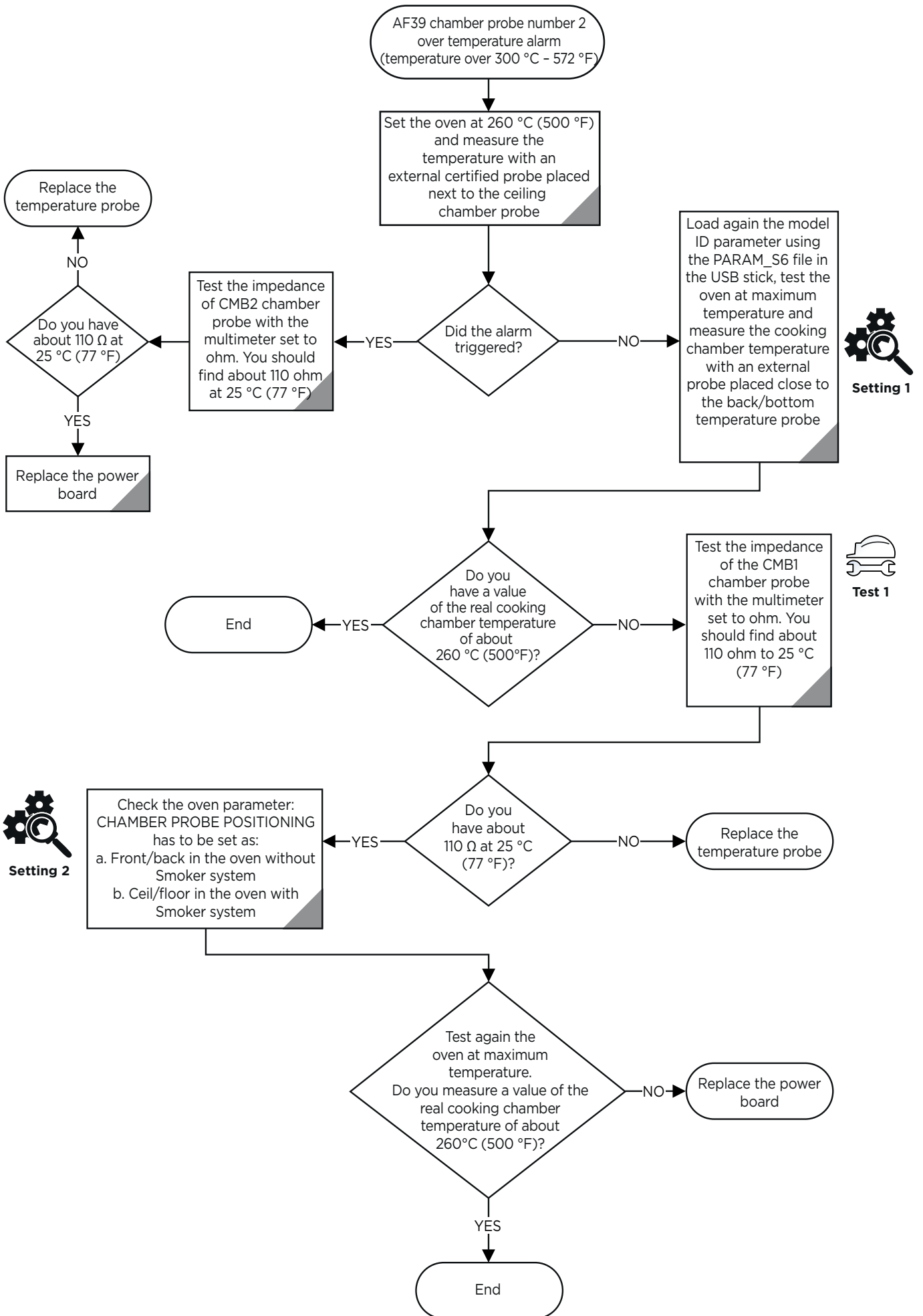



Test to do

Load the parameter file procedure



Setting 1

- ① Connect the USB stick to the USB port
- ② Press the **SETTINGS** function (gear icon).
- ③ Enter the user menu (pin: **99857**)
- ④ Press **UTILITIES** function.
- ⑤ Press **LOAD MODEL PARAM.**
Function to load model parameters and enter the model of the oven (i.e. XEVC-0511-EPR).
- ⑥ Press **OK** to save the model parameters.



Setting 2

- ① Press the **SETTINGS** function (gear icon).
- ② Enter the user menu (pin: **99857**)
- ③ Press **OVEN SETUP** function.
- ④ Press **OPTIONS** function.
- ⑤ Press **CHAMBER PROBES POSITIONING** function.
- ⑥ Set the parameter as **FRONT/BACK**.

Test 1 Measure the impedance of the CMB1 chamber probe

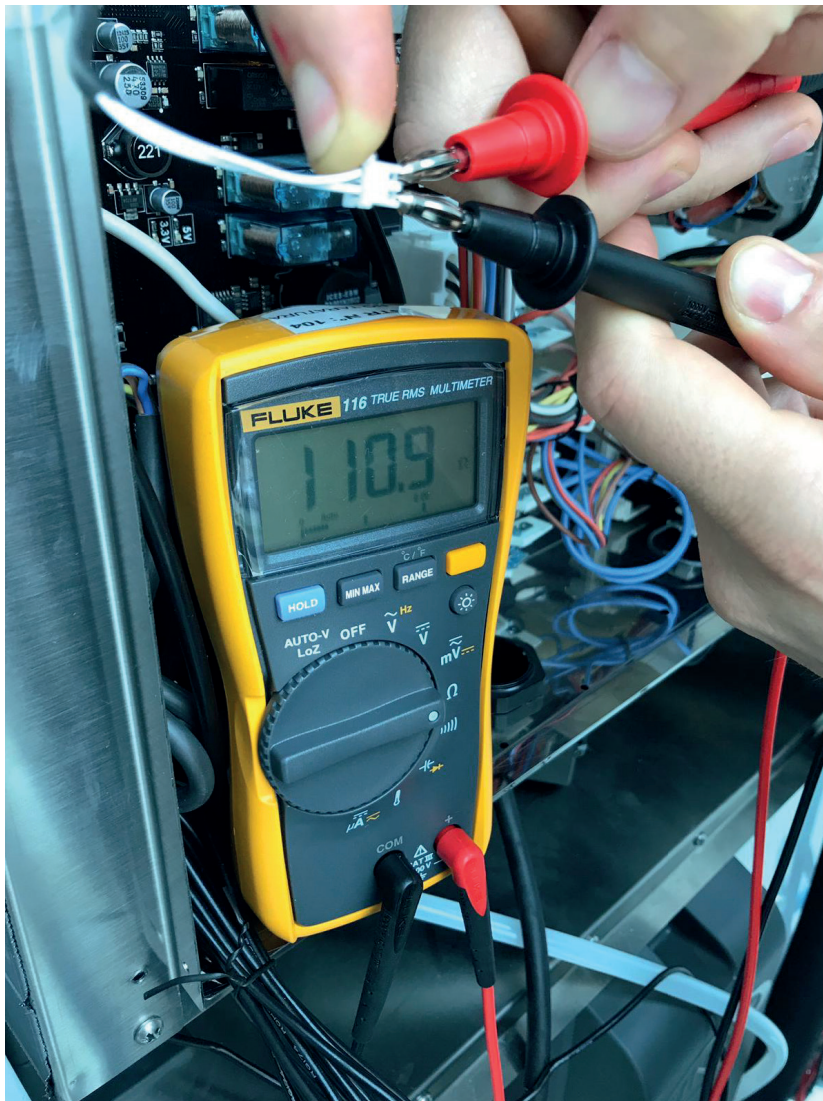

Pt100 Temperature Probe Resistance table

°C	0	1	2	3	4	5	6	7	8	9
10	103.9	104.29	104.68	105.07	105.46	105.85	106.24	106.63	107.02	107.4
20	107.79	108.18	108.57	108.96	109.35	109.73	110.12	110.51	110.9	111.28
30	111.67	112.06	112.45	112.83	113.22	113.61	113.99	114.38	114.77	115.15
40	115.54	115.93	116.31	116.7	117.08	117.47	117.85	118.24	118.62	119.01
50	119.4	119.78	120.16	120.55	120.93	121.32	121.7	122.09	122.47	122.86
60	123.24	123.62	124.01	124.39	124.77	125.16	125.54	125.92	126.31	126.69
70	127.07	127.45	127.84	128.22	128.6	128.98	129.37	129.75	130.13	130.51
80	130.89	131.27	131.66	132.04	132.42	132.8	133.18	133.56	133.94	134.32
90	134.7	135.08	135.46	135.84	136.22	136.6	136.98	137.36	137.74	138.12
100	138.5	138.88	139.26	139.64	140.02	140.39	140.77	141.15	141.53	141.91
110	142.29	142.66	143.04	143.42	143.8	144.17	144.55	144.93	145.31	145.68
120	146.06	146.44	146.81	147.19	147.57	147.94	148.32	148.7	149.07	149.45
130	149.82	150.2	150.57	150.95	151.33	151.7	152.08	152.45	152.83	153.2
140	153.58	153.95	154.32	154.7	155.07	155.45	155.82	156.19	156.57	156.94
150	157.31	157.69	158.06	158.43	158.81	159.18	159.55	159.93	160.3	160.67
160	161.04	161.42	161.79	162.16	162.53	162.9	163.27	163.65	164.02	164.39
170	164.76	165.13	165.5	165.87	166.24	166.61	166.98	167.35	167.72	168.09
180	168.46	168.83	169.2	169.57	169.94	170.31	170.68	171.05	171.42	171.79
190	172.16	172.53	172.9	173.26	173.63	174	174.37	174.74	175.1	175.47
200	175.84	176.21	176.57	176.94	177.31	177.68	178.04	178.41	178.78	179.14
210	179.51	179.88	180.24	180.61	180.97	181.34	181.71	182.07	182.44	182.8
220	183.17	183.53	183.9	184.26	184.63	184.99	185.36	185.72	186.09	186.45
230	186.82	187.18	187.54	187.91	188.27	188.63	189	189.36	189.72	190.09
240	190.45	190.81	191.18	191.54	191.9	192.26	192.63	192.99	193.35	193.71
250	194.07	194.44	194.8	195.16	195.52	195.88	196.24	196.6	196.96	197.33
260	197.69	198.05	198.41	198.77	199.13	199.49	199.85	200.21	200.57	200.93

AF41 - CASE 1, T > 150 °C (302 °F)

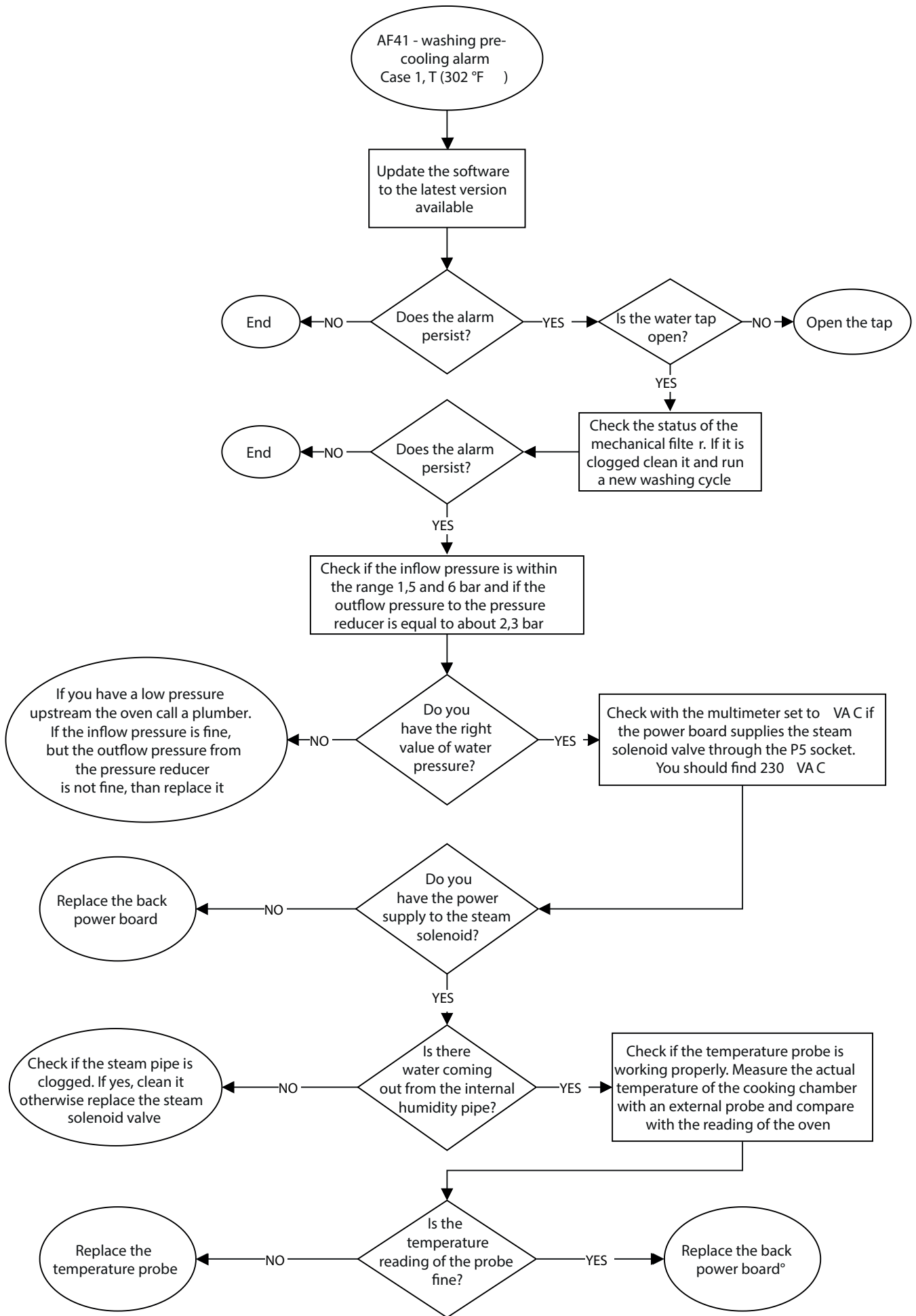

AF41 - CASE 2, T < 150 °C (302 °F)

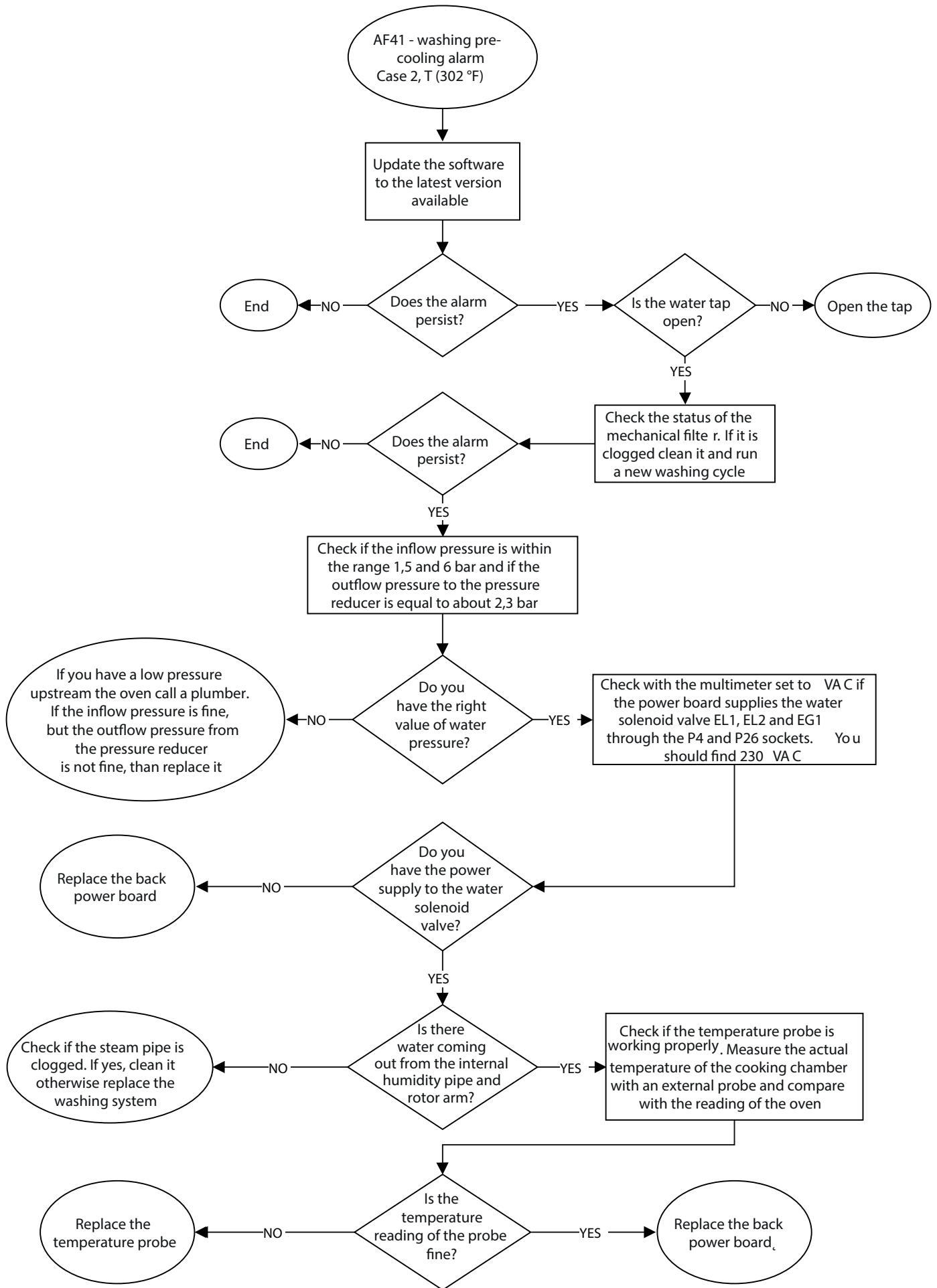

AF43 - SINGLE-POINT OR MULTI-POINT CORE PROBE COMPLETELY DAMAGED

If the client doesn't use the core probe go to Service Menu>Accessory settings> Core Probe > OFF

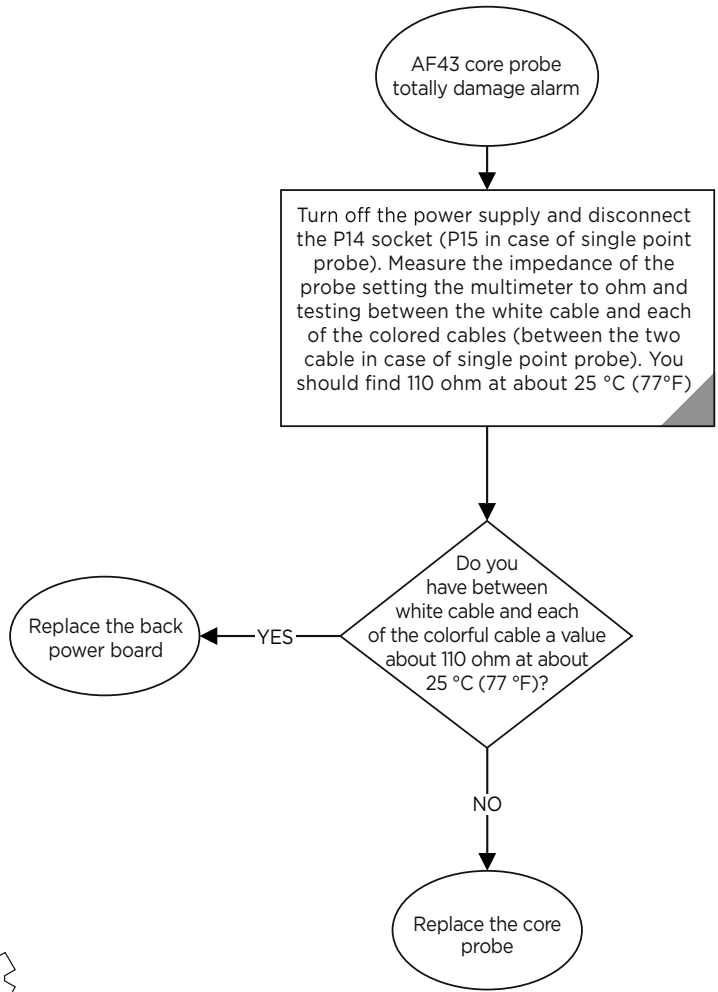

In case of single point core probe the check to do are the same but you have just a couple of wires

Test 1 Measure the impedance of the probe



WF01 - WF02 CHAMBER TEMPERATURE PROBE

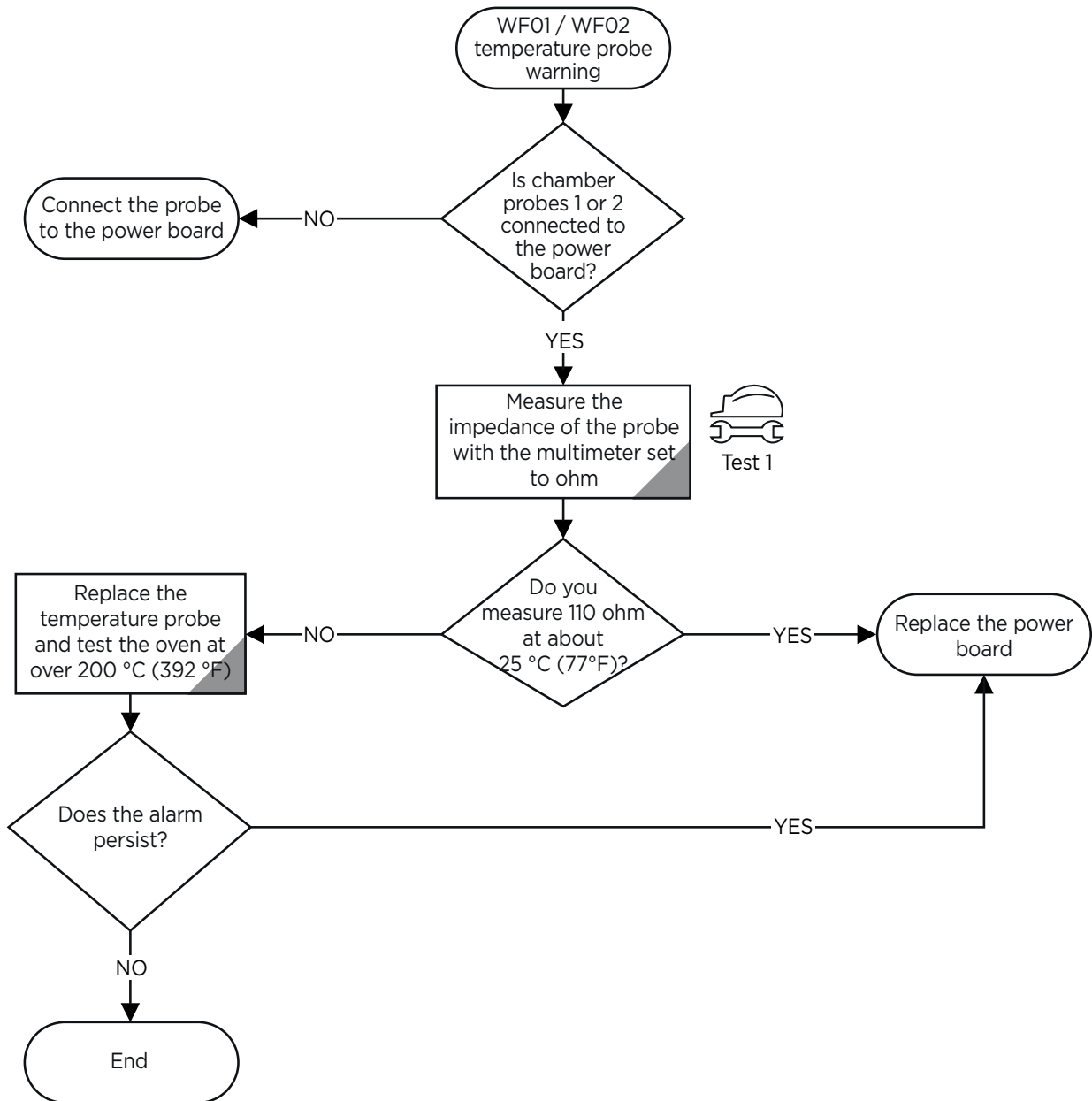

Test 1 Measure the impedance of the probe

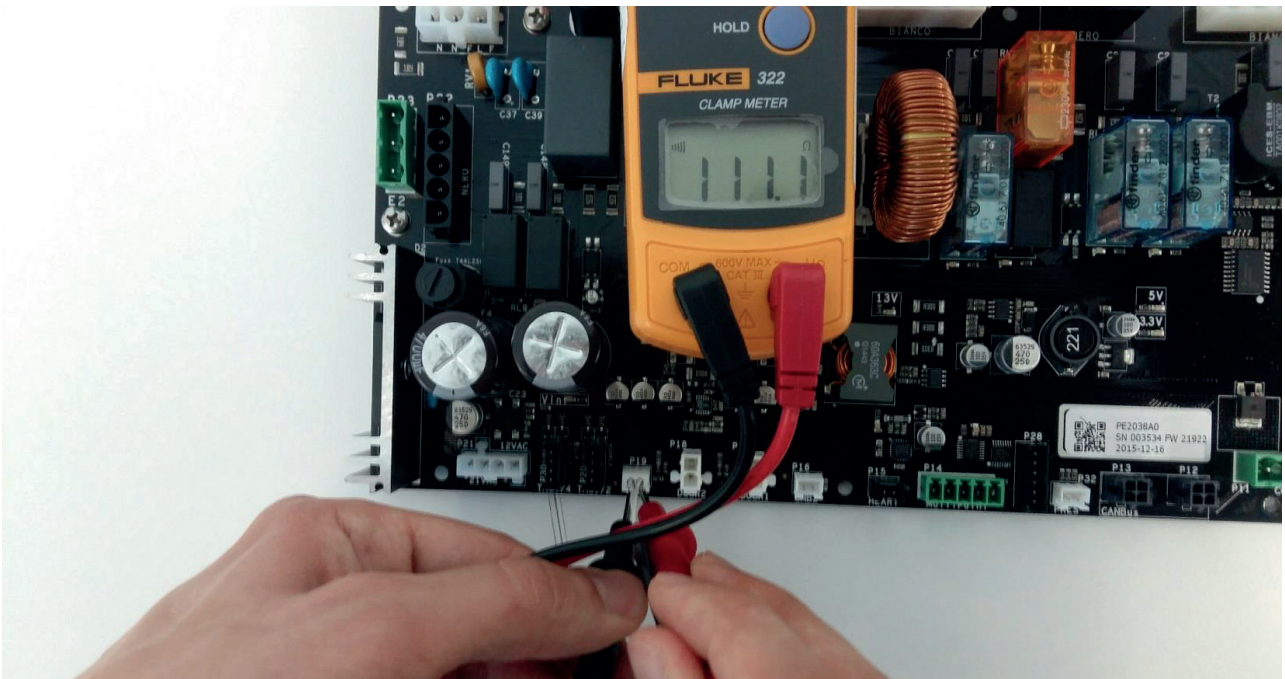

WF04 - AF08 FAN SPEED ERROR

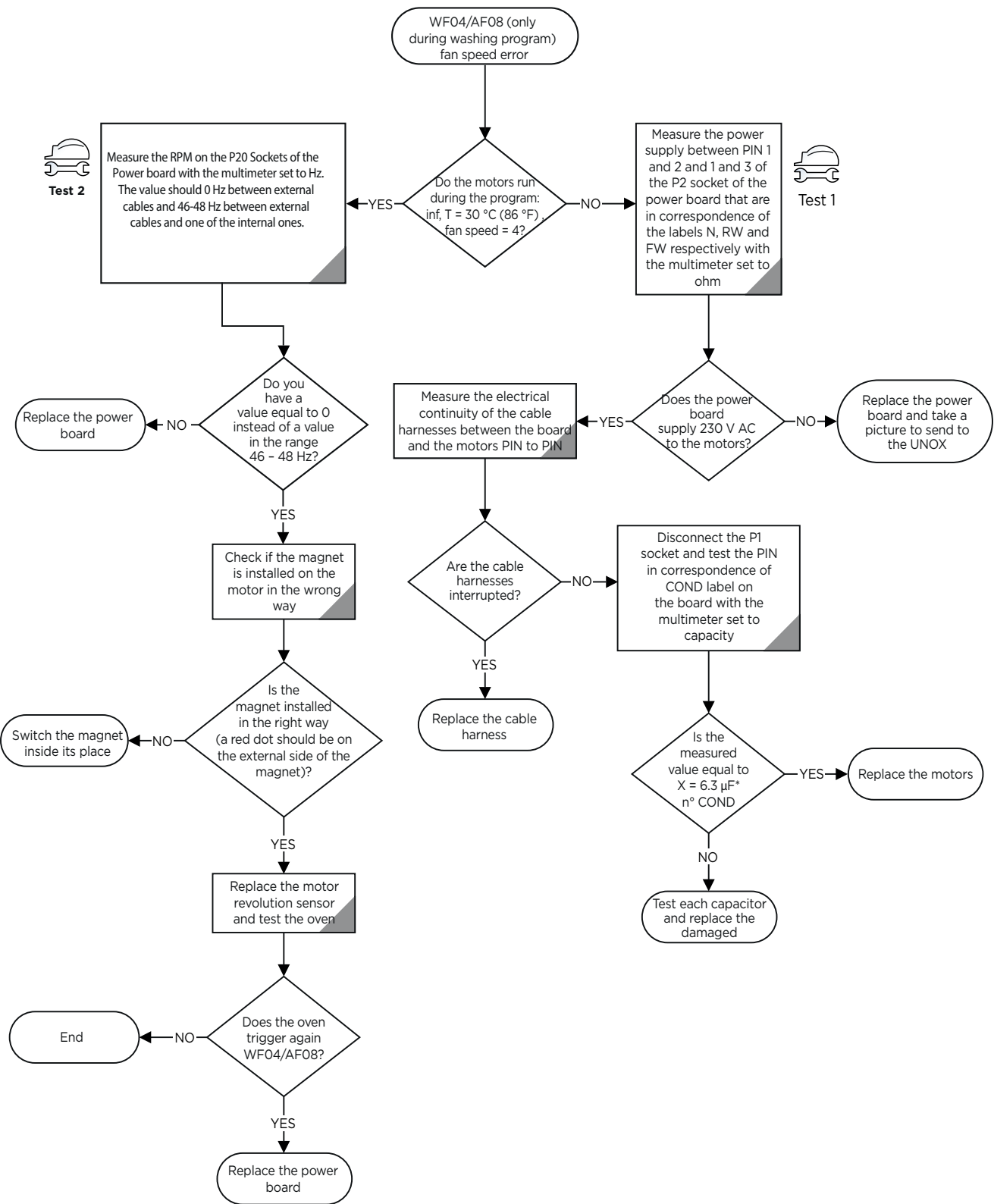



Test to do

Test 1 Measure the motor power supply from the power board

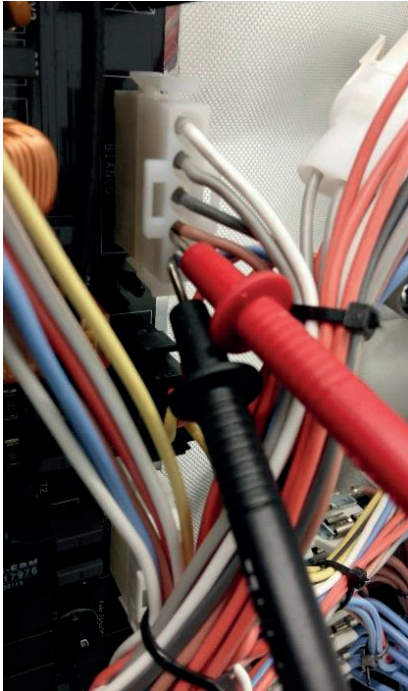

Test 2 Measure the RPM on the P20 socket

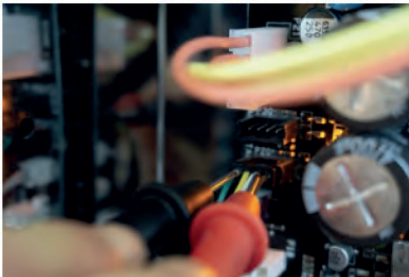

WF06 - POWER BOARD TEMPERATURE WARNING

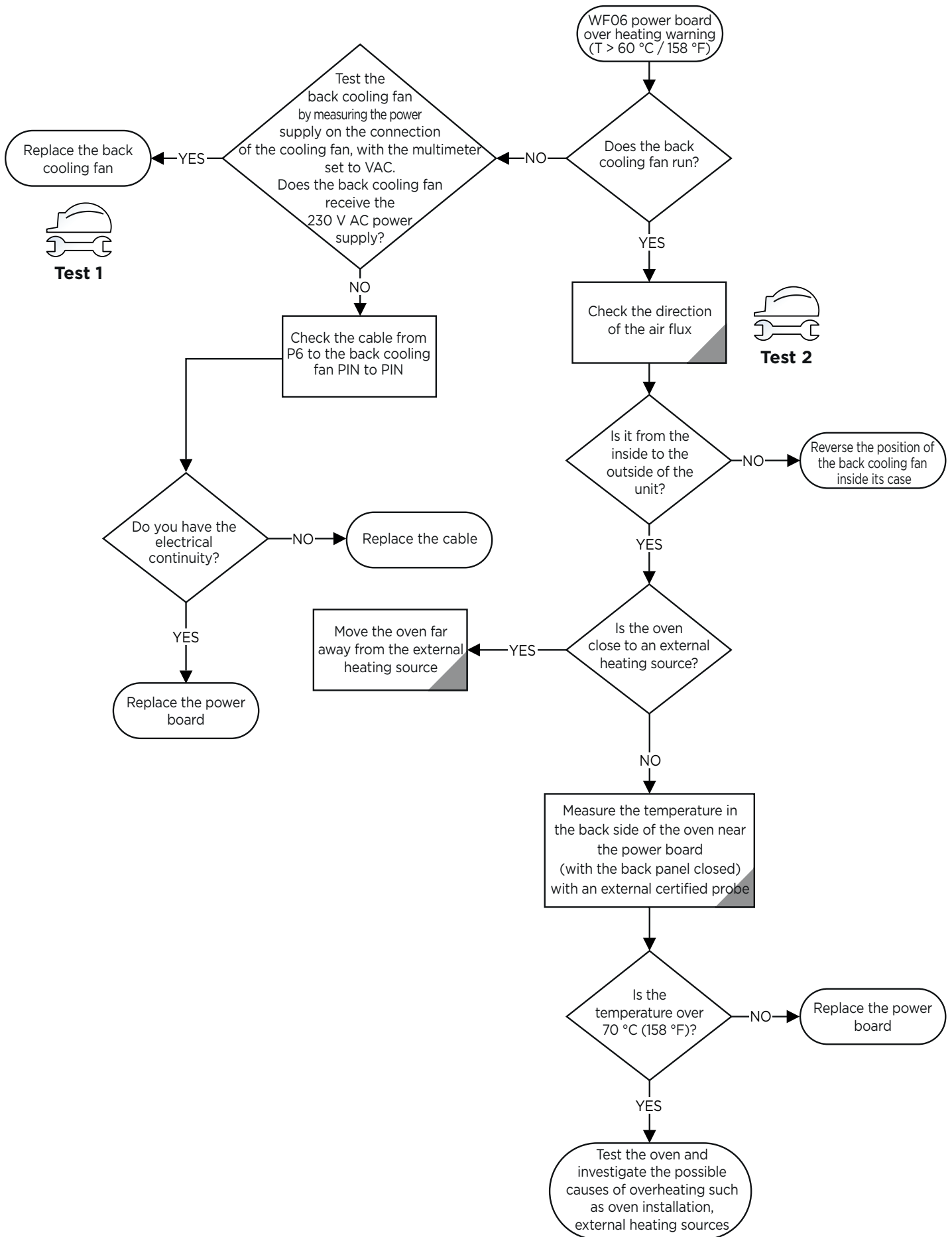

Test 1 Back cooling 230 V AC power supply



Fan is running in the right direction

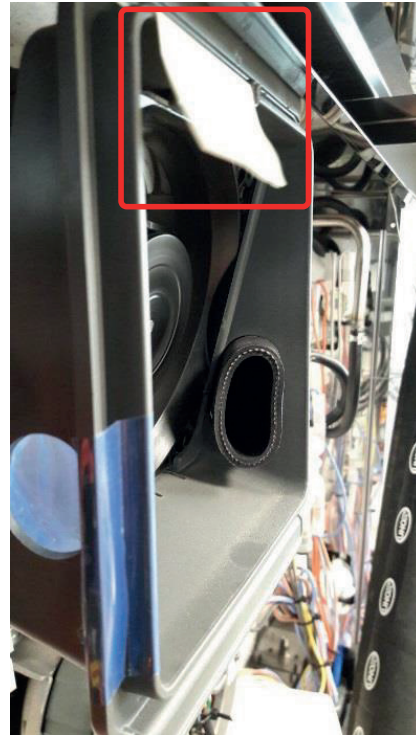

Fan is not running in the right direction

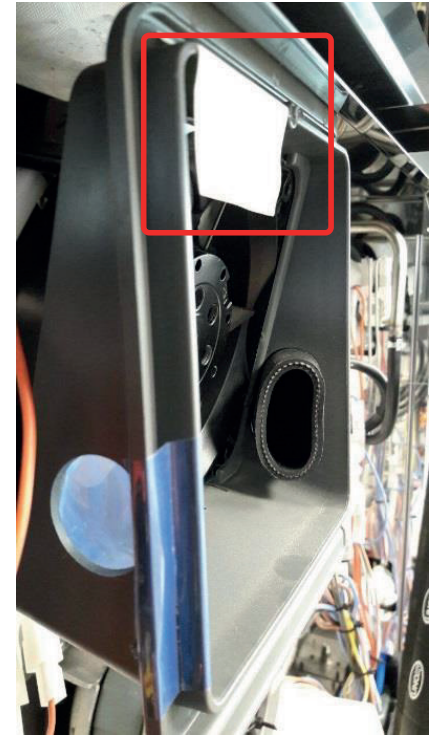

WF16 - LACK OF WATER OR EL1

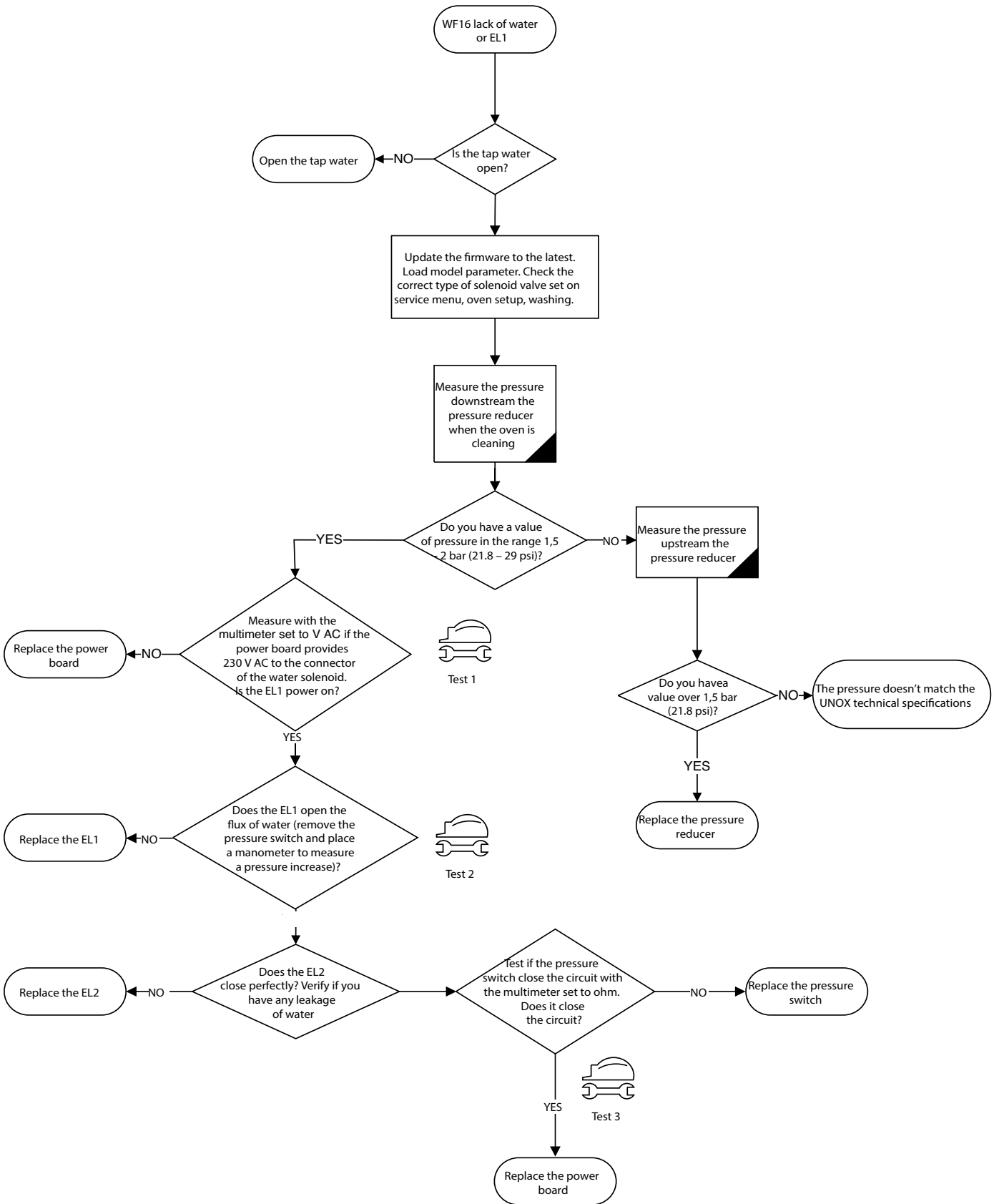

Cleaning systems as of December 2019

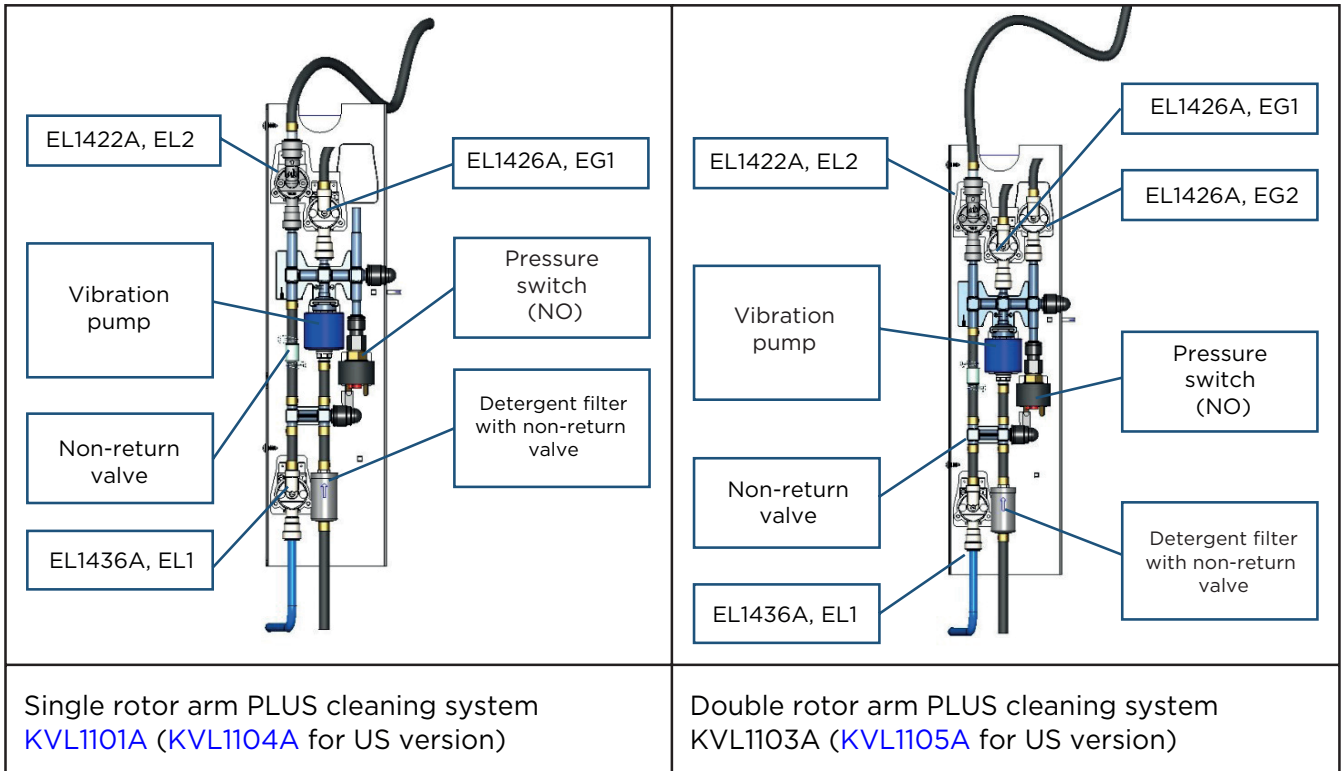

Cleaning Systems After 2019 with the Self Cleaning Solenoid Valves

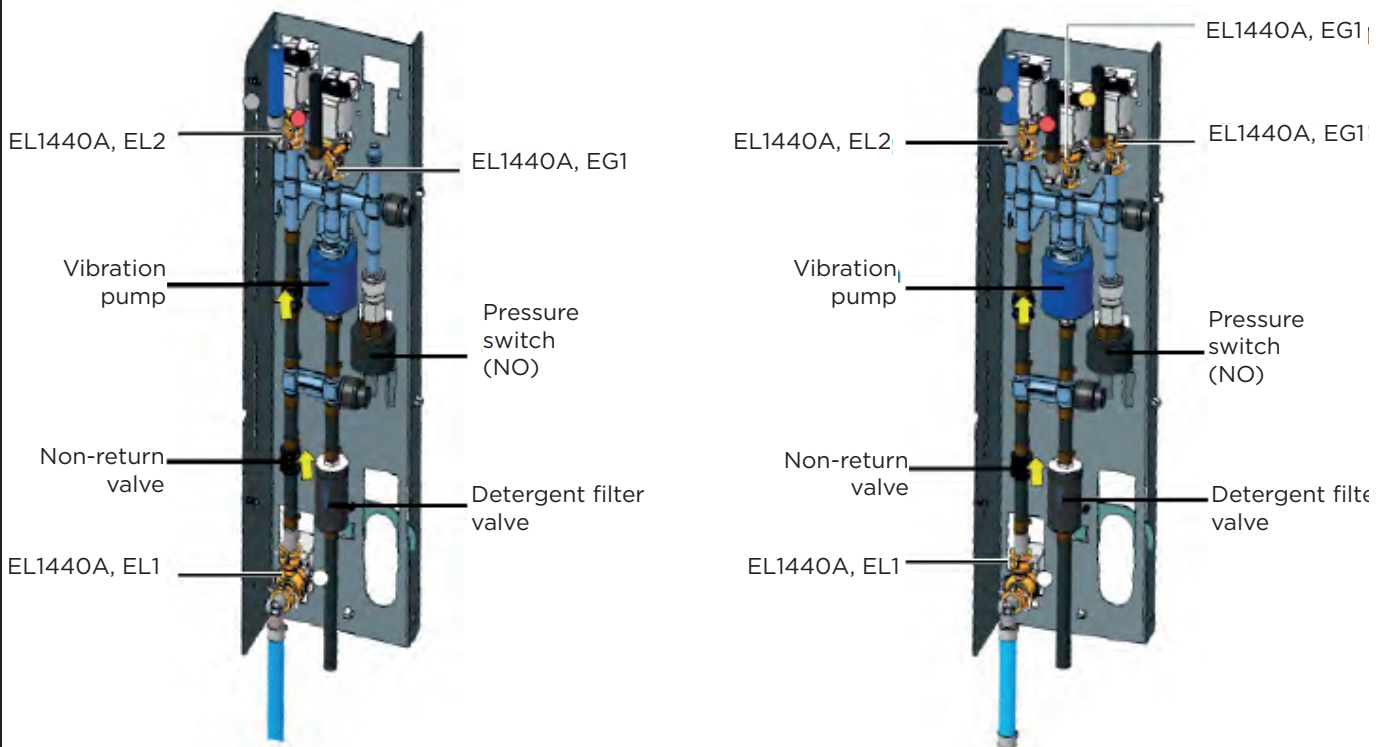

Single rotor arm PLUS cleaning system
KVL1183A (KVL1207A for US version)

2 rotor arms PLUS cleaning system
KVL1184A (KVL1208A for US version)

3 rotor arms PLUS cleaning system
KVL1187A (KVL1209A for US version)

Test 1 Measure the power supply to the washing solenoid valve



Test 2



Low pressure status



High pressure status

Test 3



Low pressure status

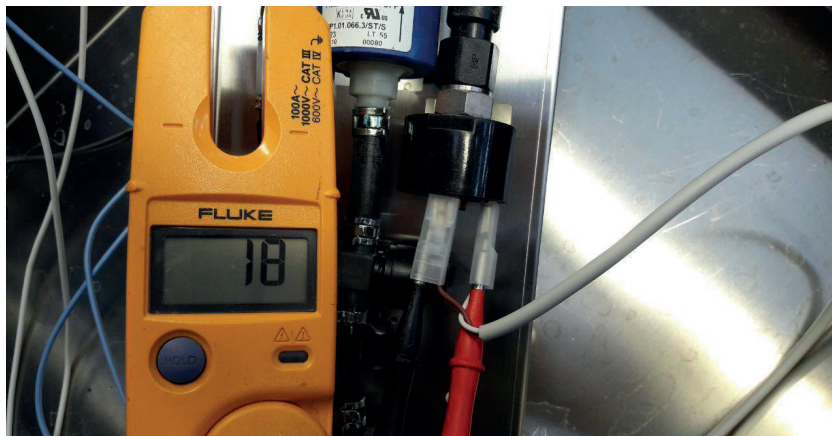

High pressure status

WF17 - PARTIAL BREAKING OF MULTIPOINT PROBE

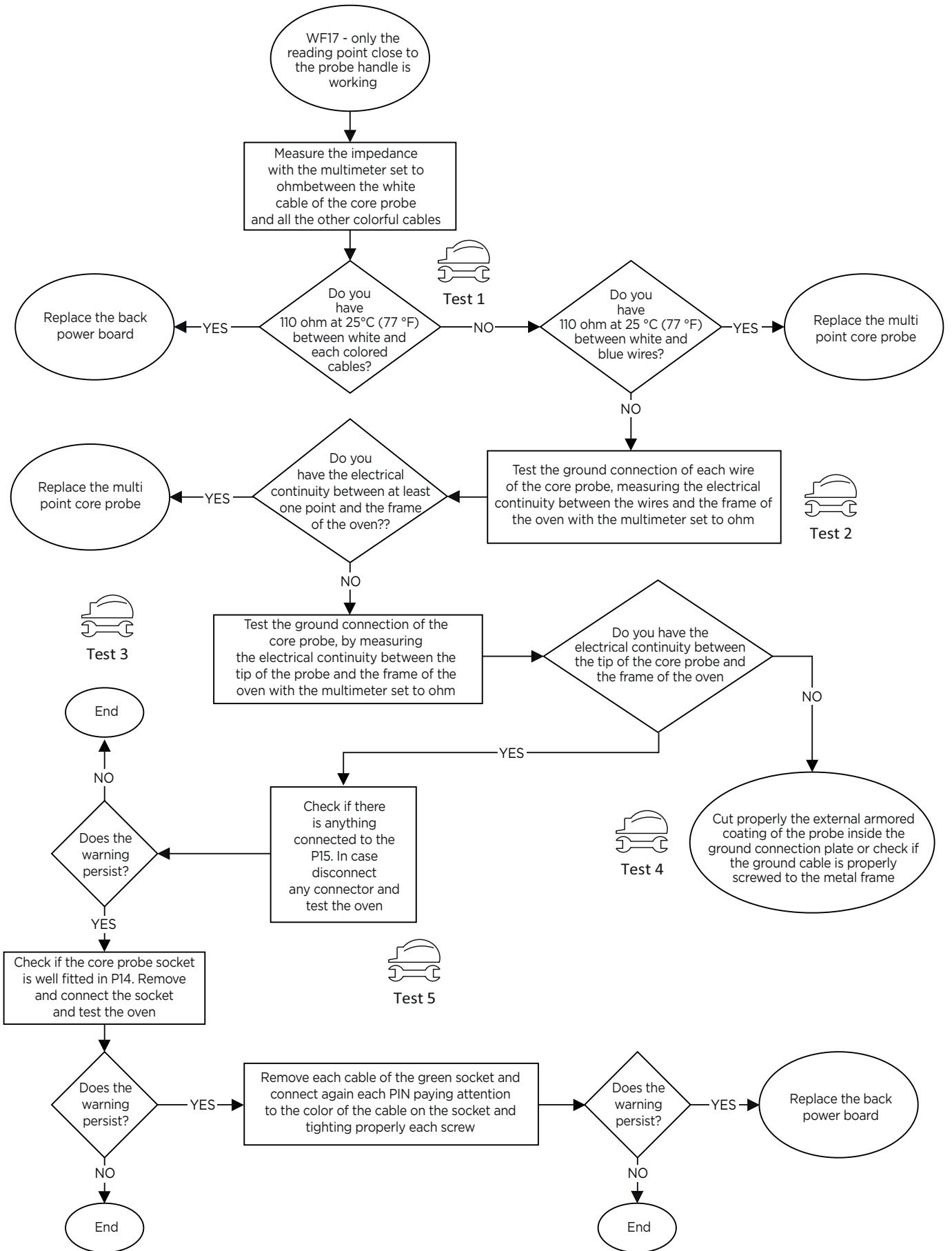

Test 1 Measure 110 ohm at 25°C (77 °F) between white and each colored

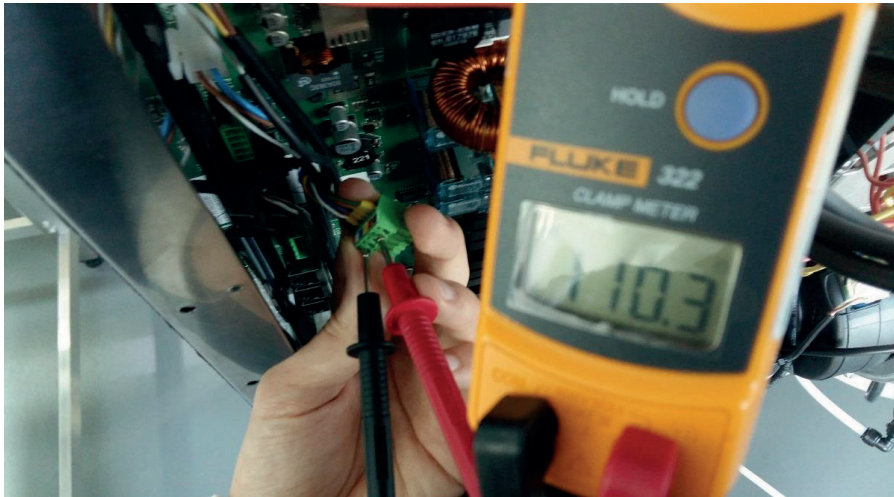

Test 2 Test the ground connection of each wire of the core probe

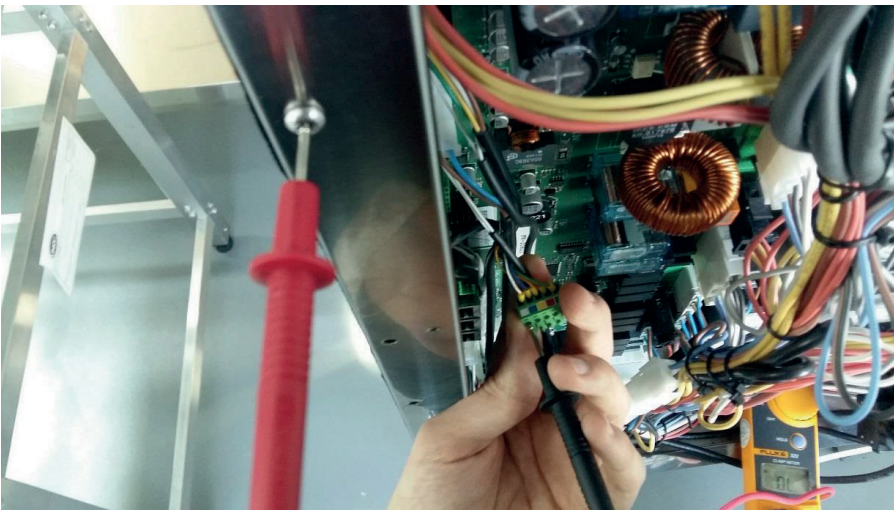

Test 3 Test the ground connection of the core probe

Test 4 Check the screws on the socket

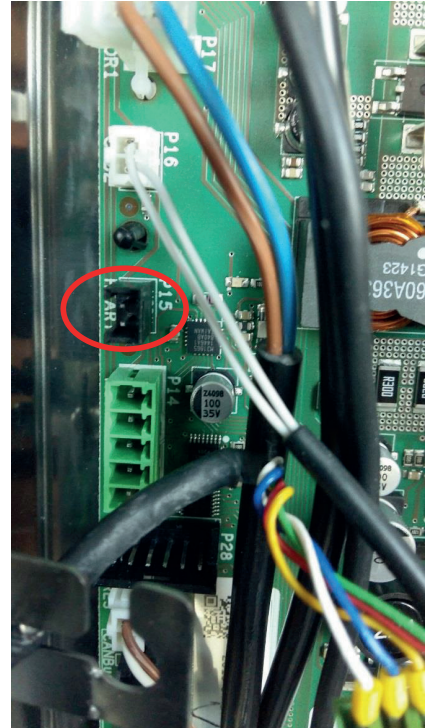

WF19 - LACK OF DETERGENT

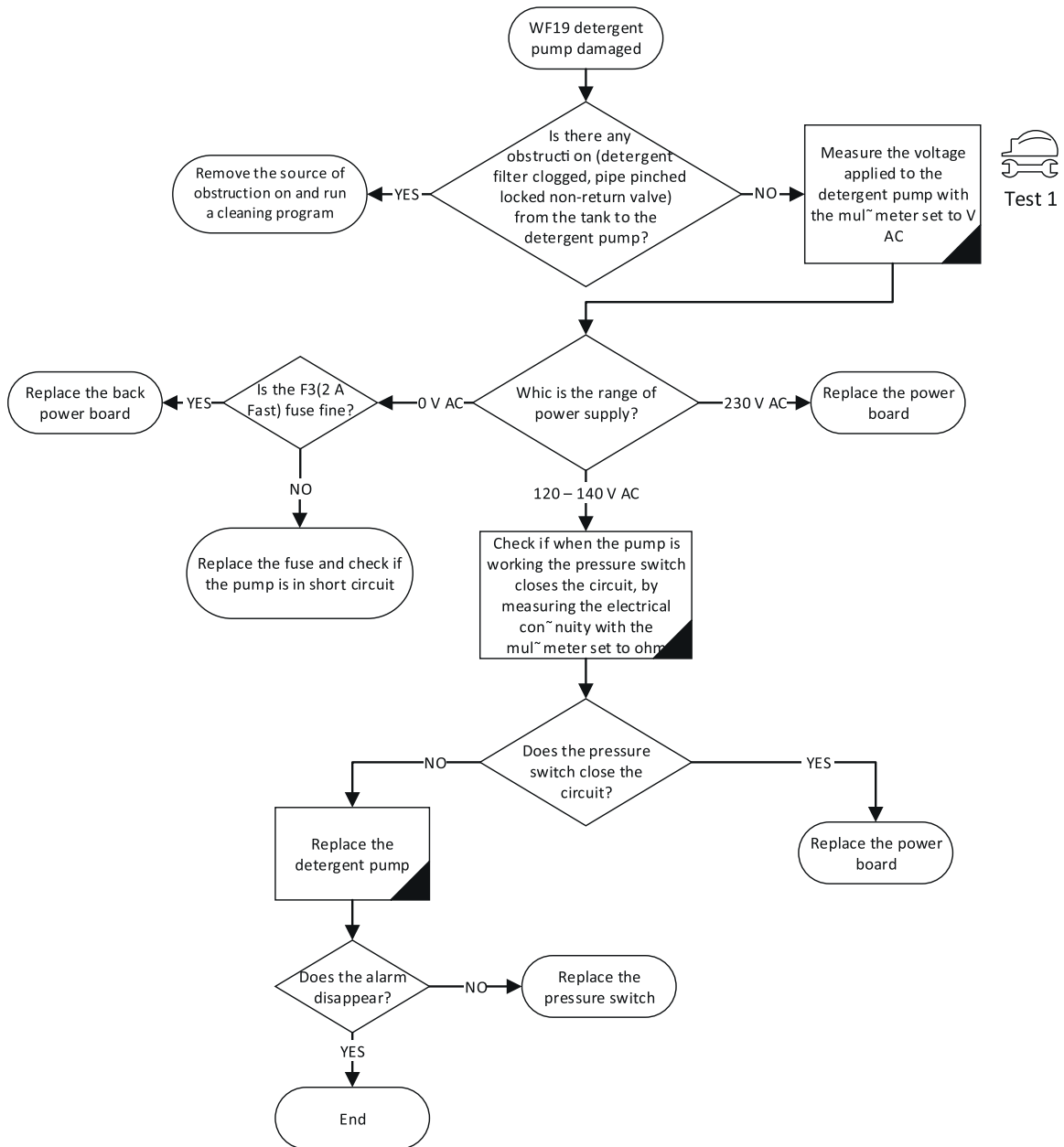

Test 1 Measure the voltage applied to the detergent pump



WF20 - ROTOR VALVE EG1

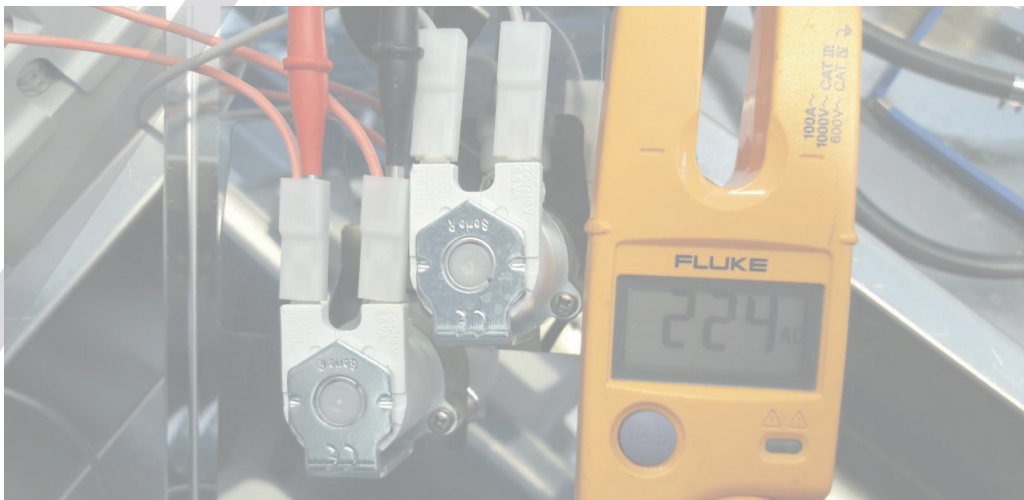
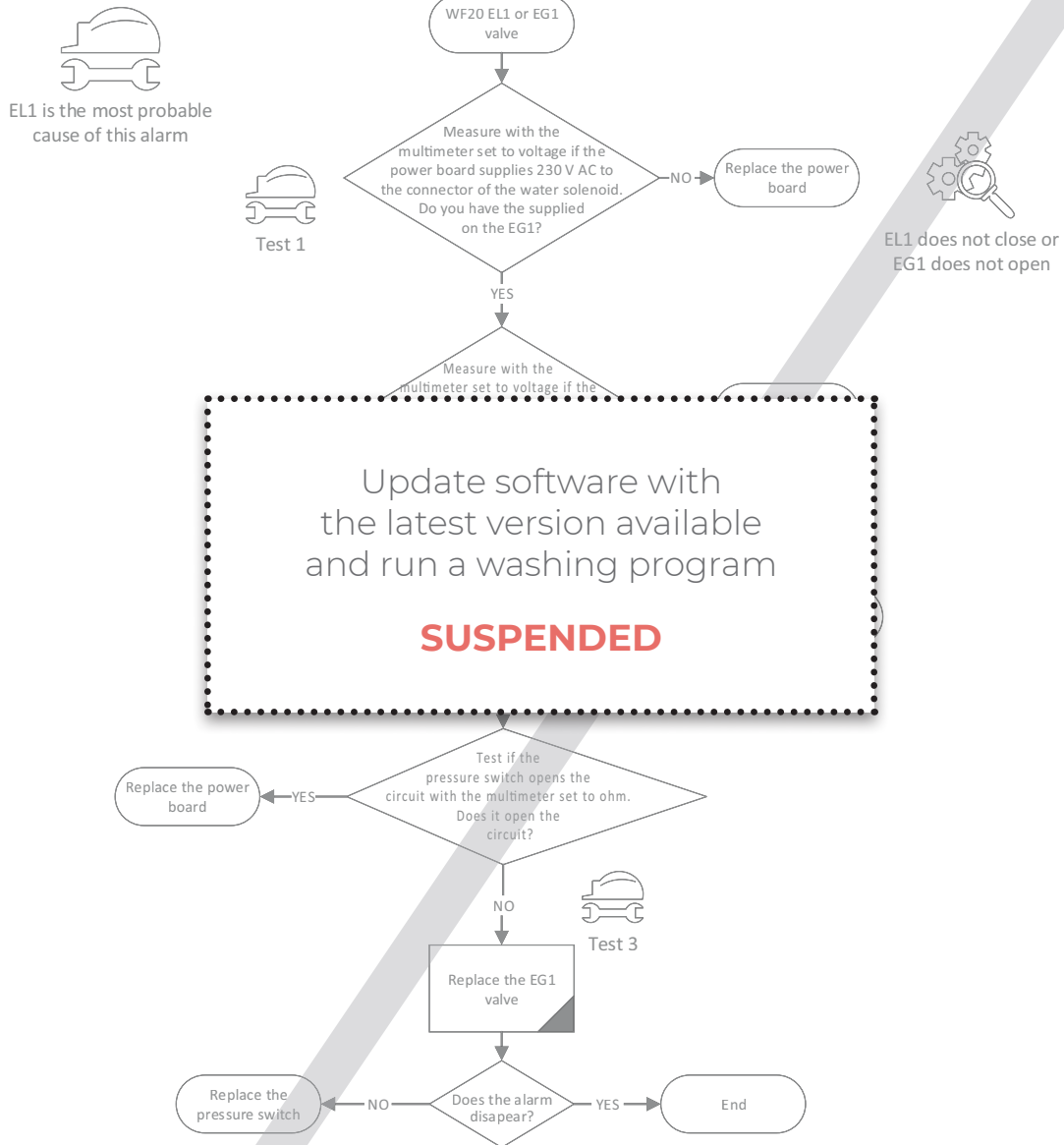

WF23 - BLOWER TACHOMETER ALARM

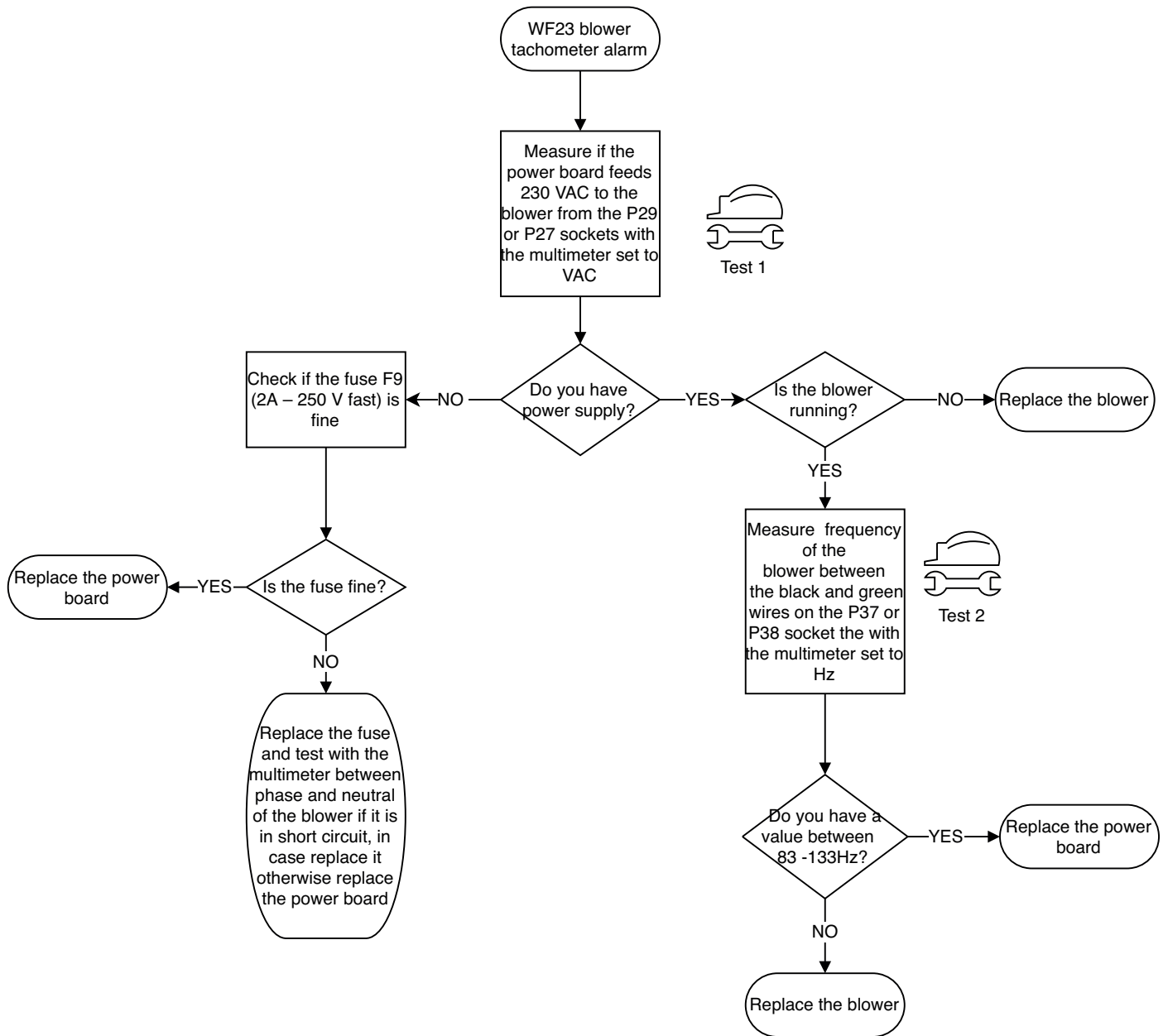

Test 1 Measure to see if the power board feeds 230 VAC to the blower

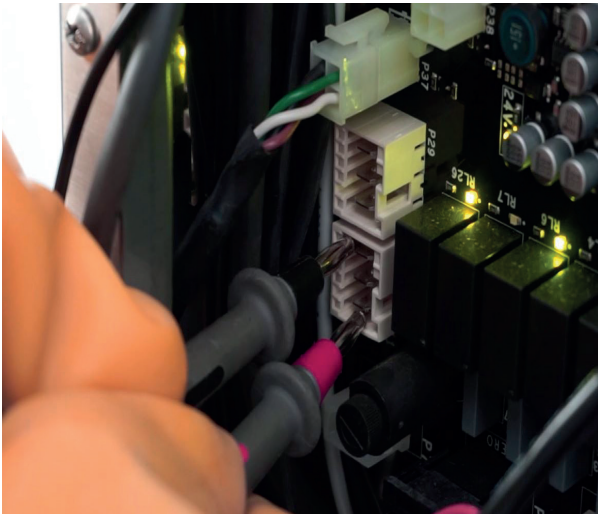

Test 2 Measure the frequency of the blower

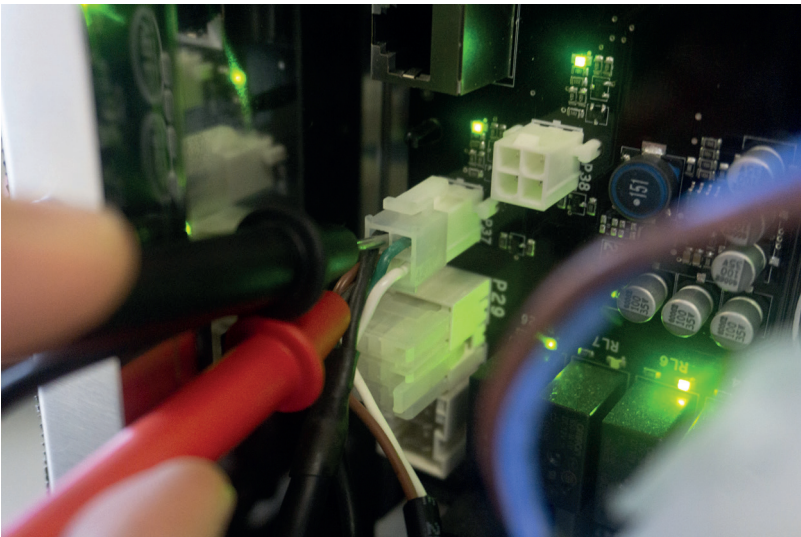

WF25 - WATER VALVE EL2

EL2 is the most probable cause of this alarm

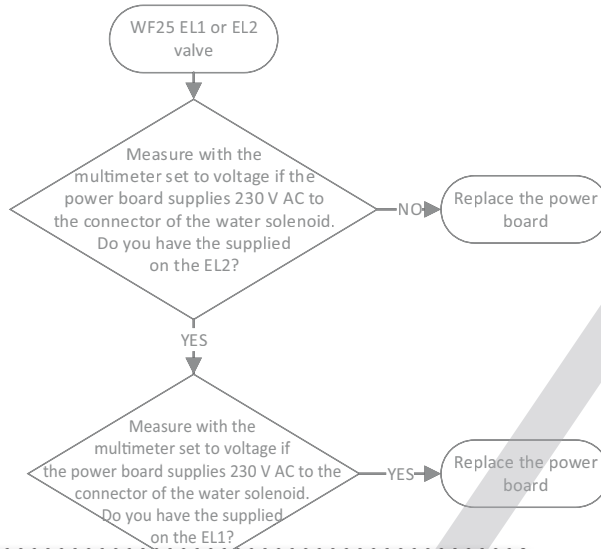

EL1 does not close c
EL2 does not open

Update software with the latest version available and run a washing program

SUSPENDED

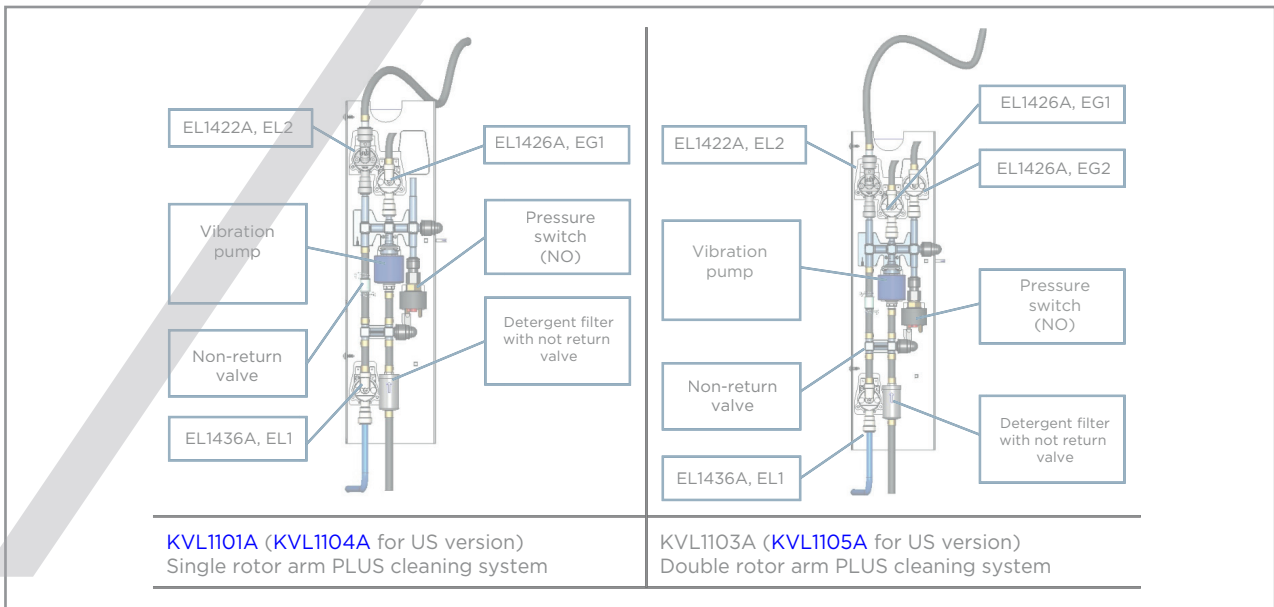
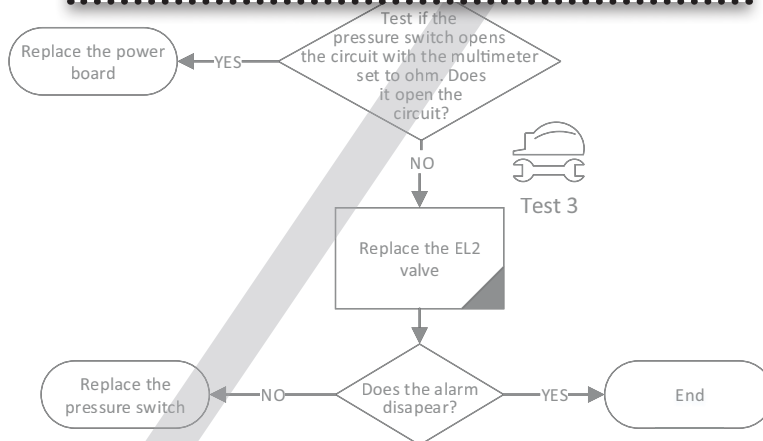

WF26 - ROTOR VALVE EG2

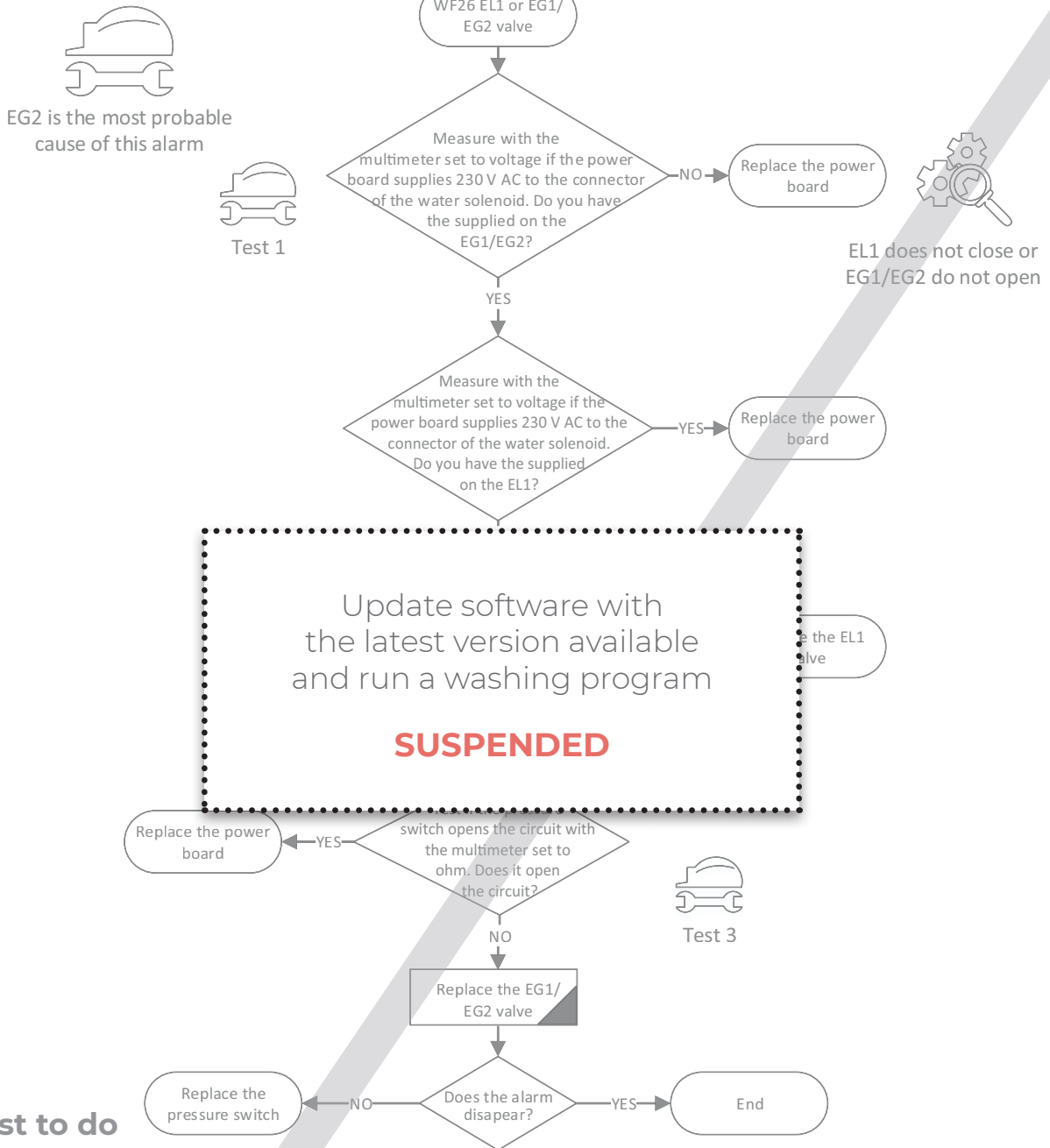

Test to do

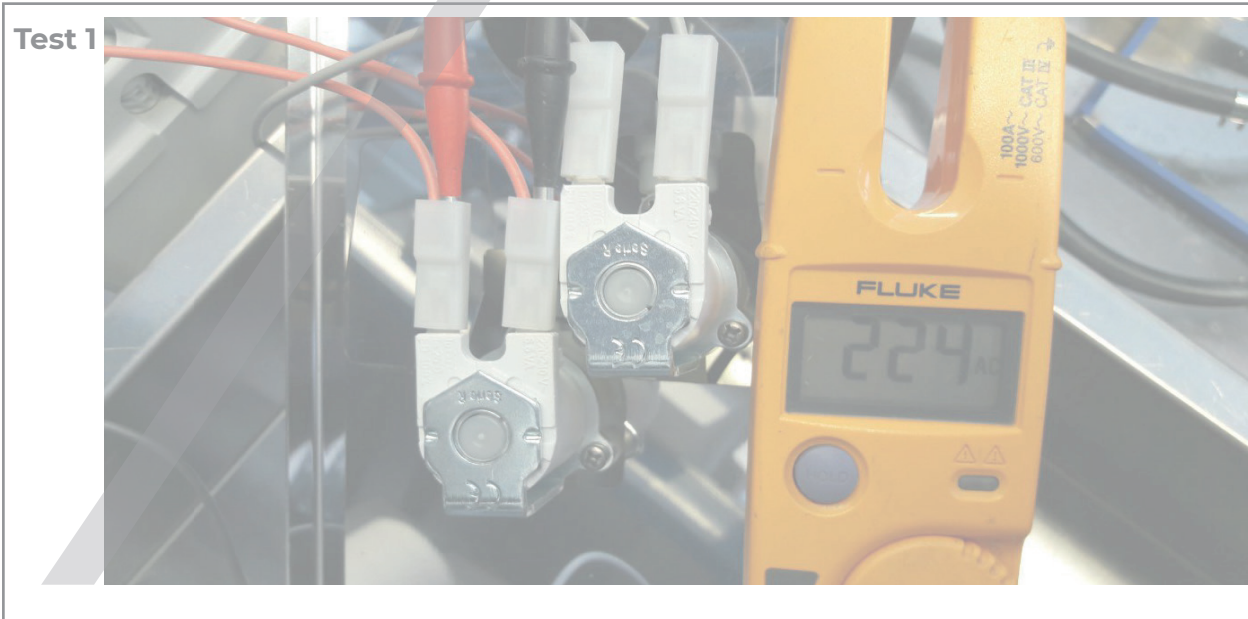

WF27 - LACK OF WATER OR VALVE EL1



Maybe chemical is in the cooking chamber



The oven checks if there is water, if EL1 does not open or if EG1 does not close

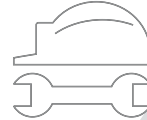

EL1 is the most probable cause of this alarm

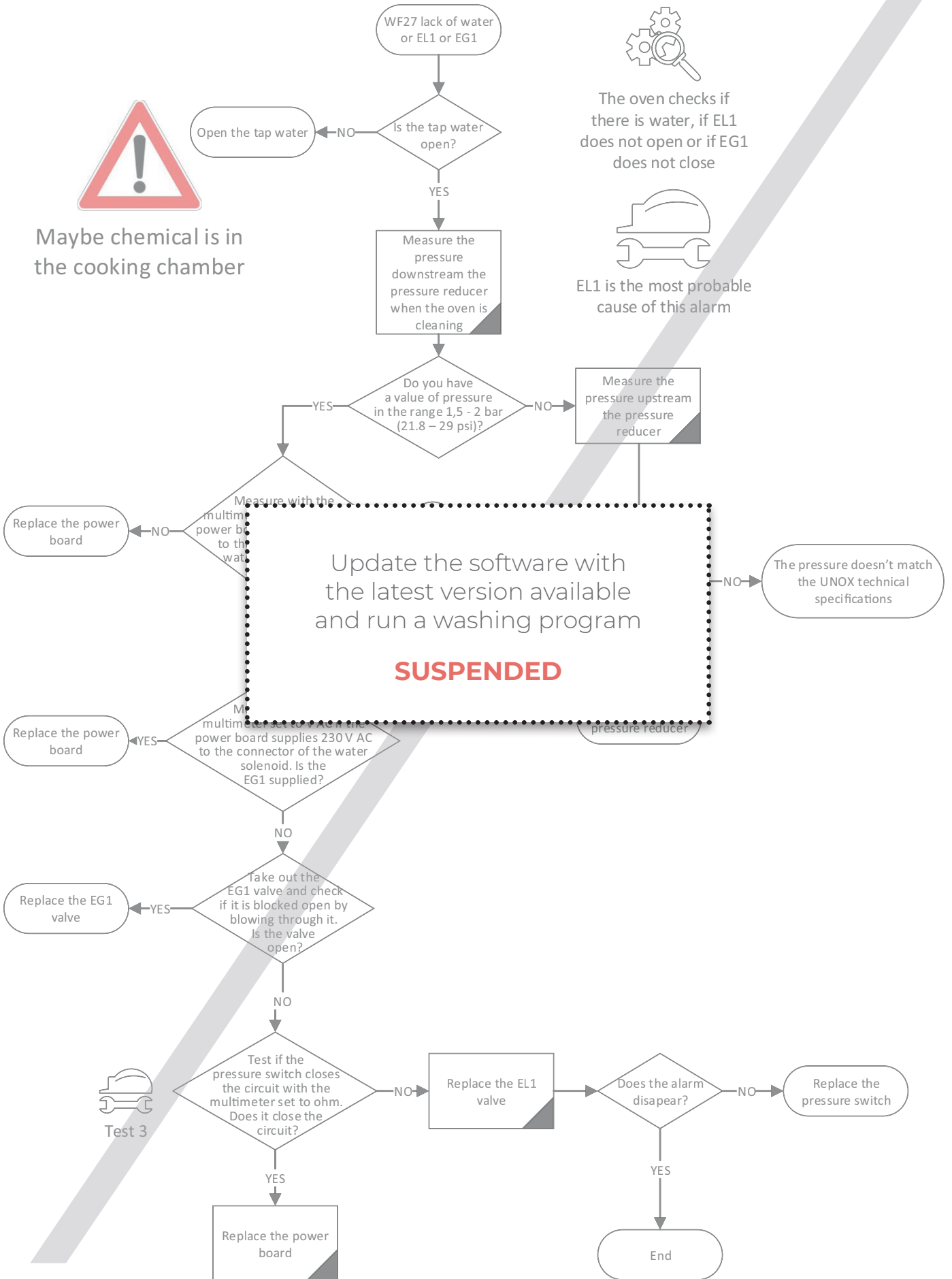

WF29 - GAS FUMES TEMPERATURE

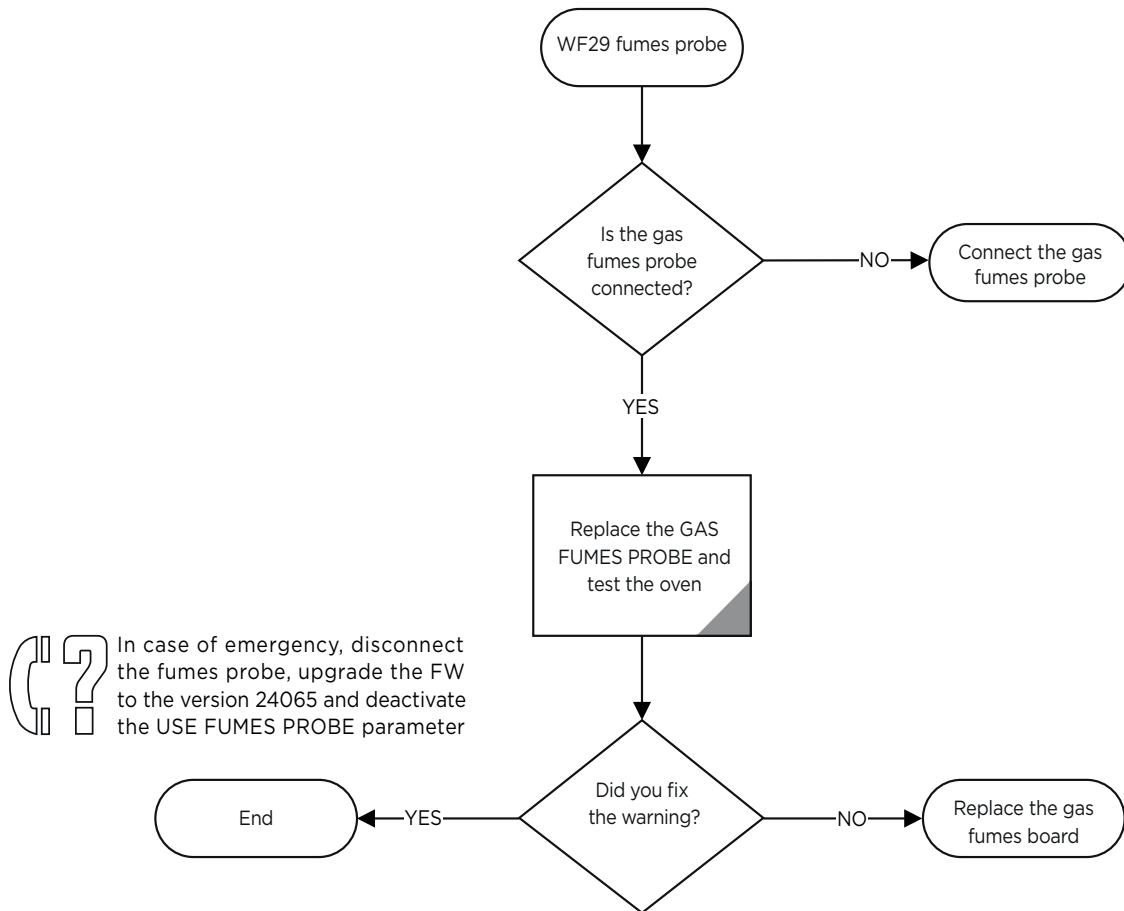

Test to do

In case of emergency, disconnect the fumes probe, upgrade the FW to the version 24065 and deactivate the USE FUMES PROBE parameter

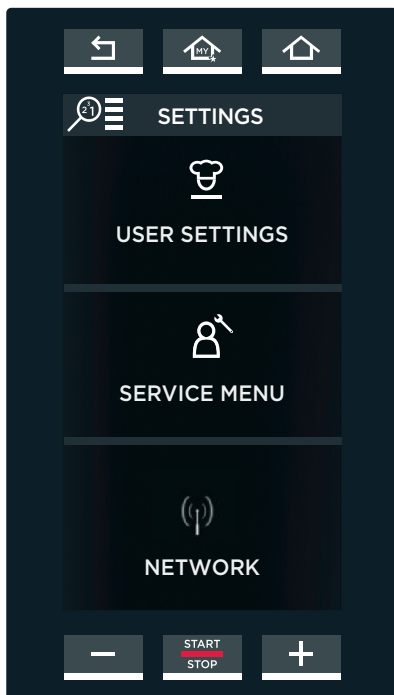

Enter the service menu



Enter the oven setup

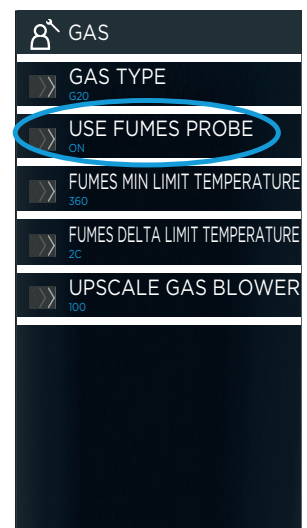

Enter in the GAS setting and set USE FUMES PROBE to OFF

WF30 - GAS FUMES PROBE BOARD COMMUNICATION ERROR

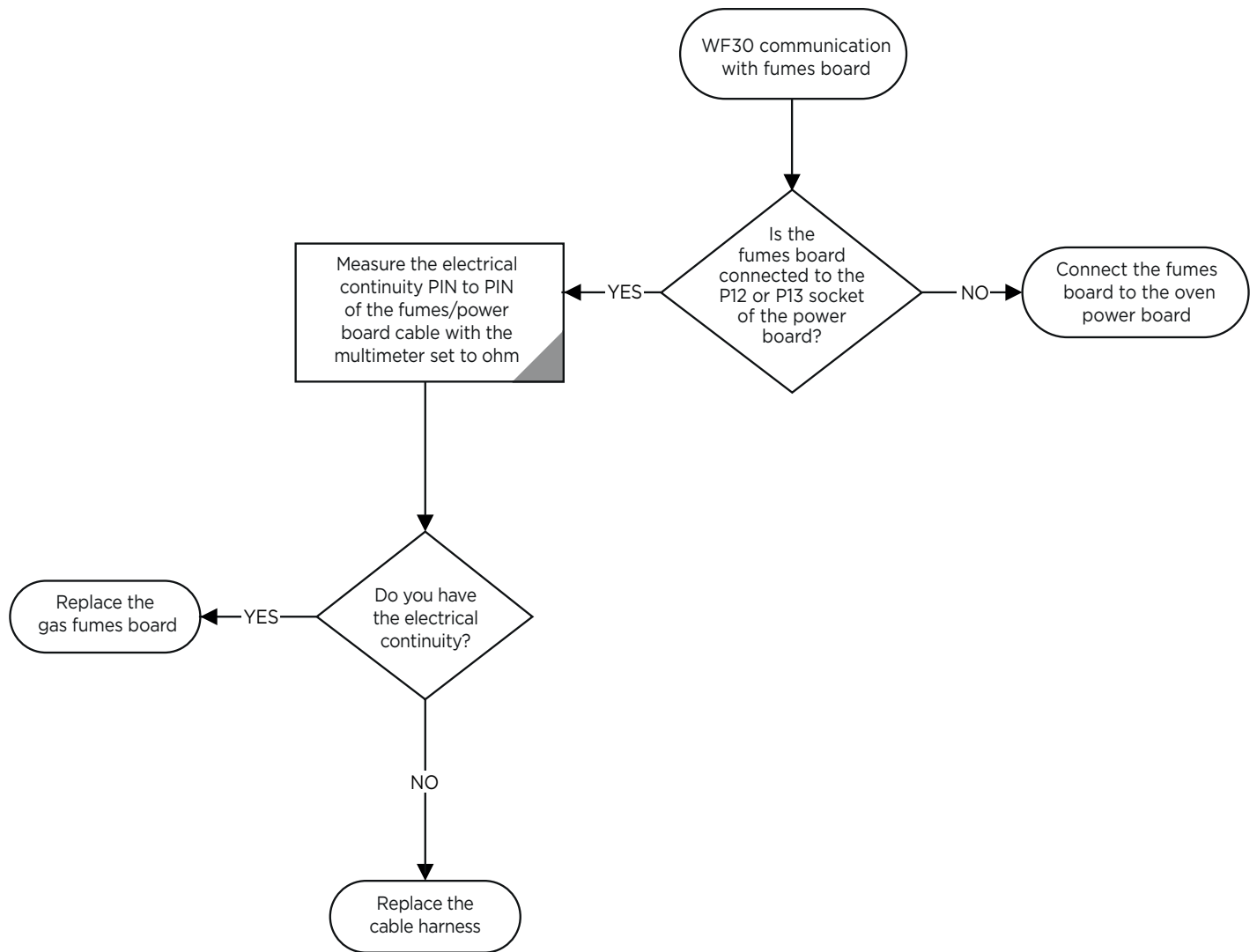

WF31 - FUMES BOARD TEMPERATURE

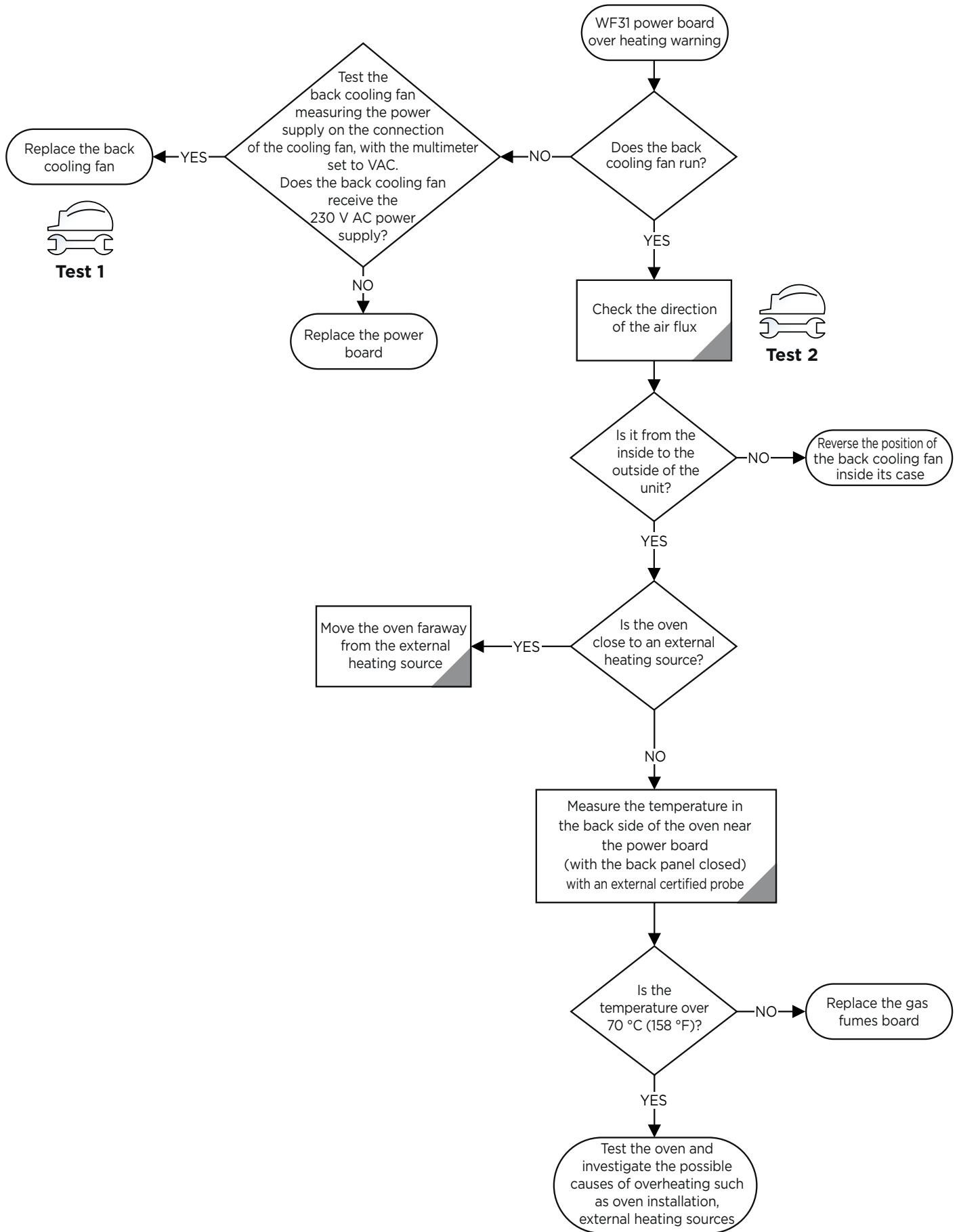



Test to do

Test 1



Test 2

Fan is running in the right direction



Fan is not running in the right direction



The right place to which place the external temperature probe is shown in the figure below. Place the external probe at 3 mm to the edge of the board to avoid short circuit.

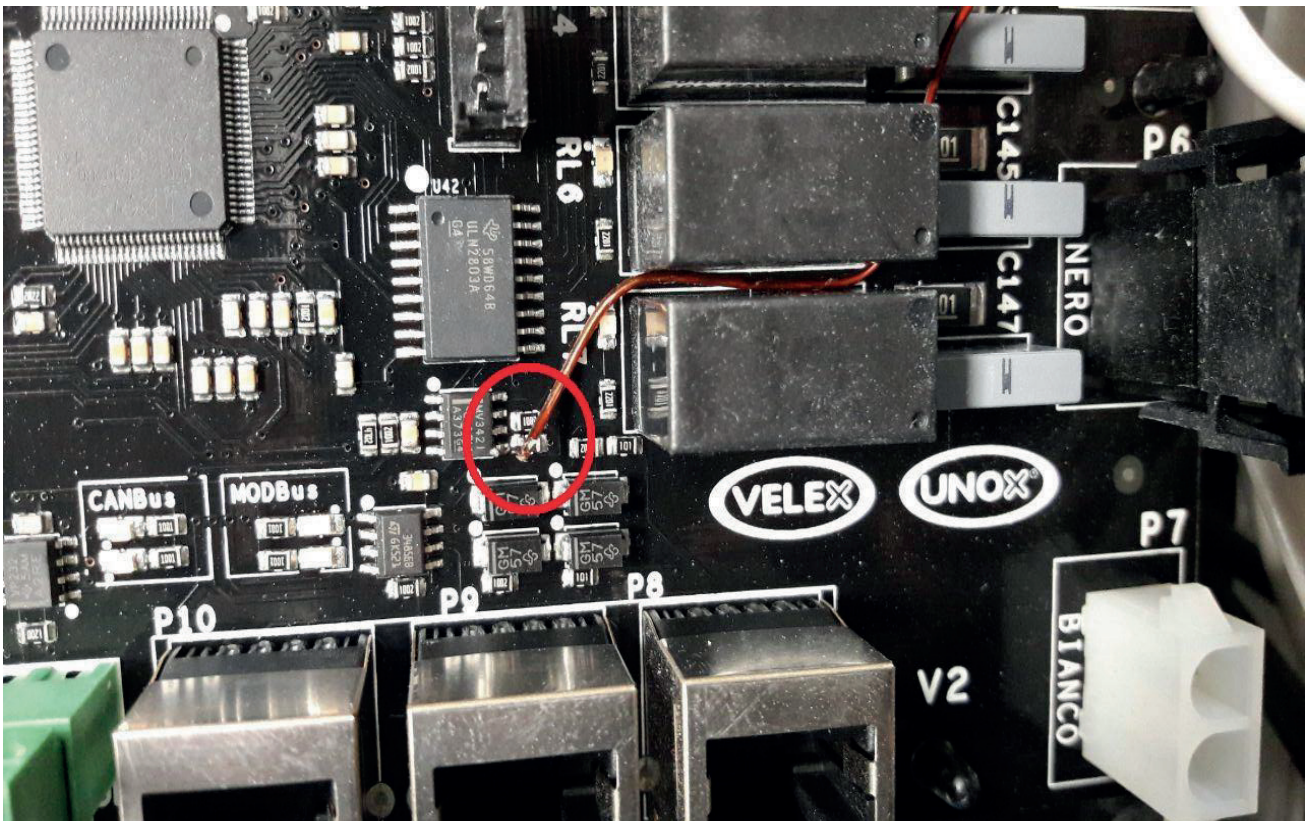

WF33/AF40 - (ONLY IN GAS OVENS) CORRUPTED SD CARD

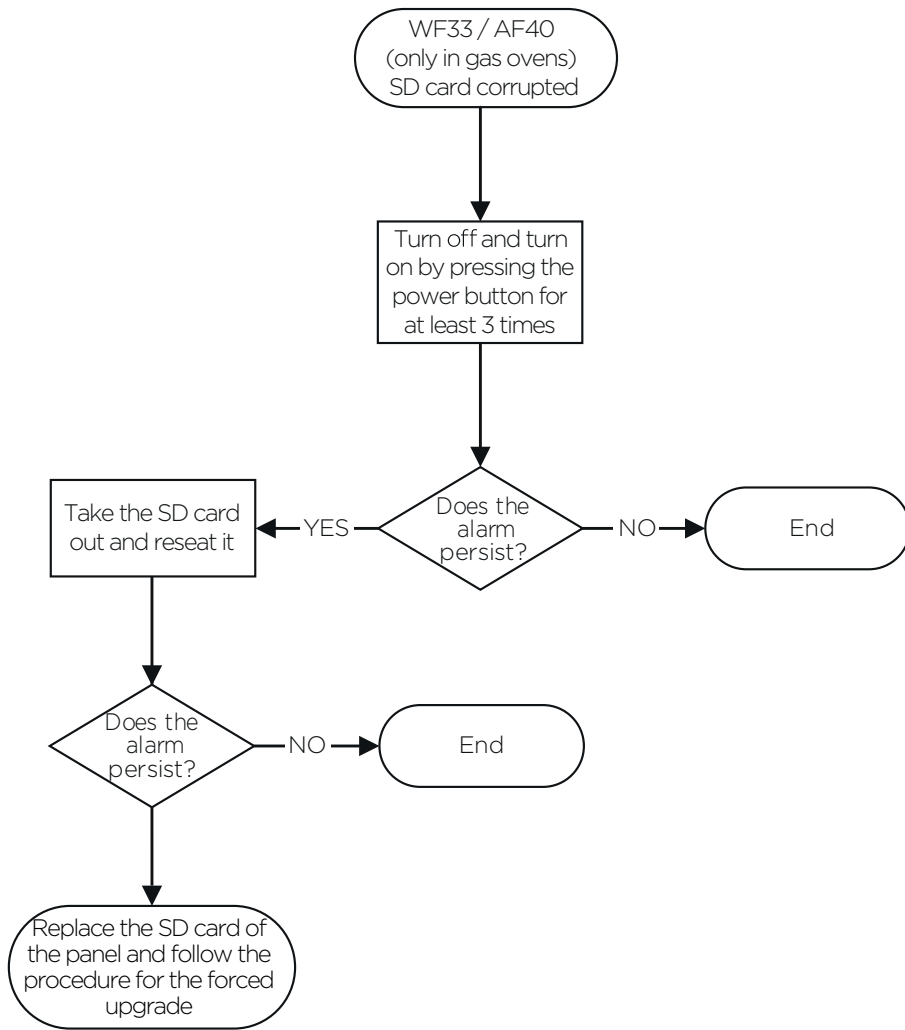

WF34 EG1 OR EL2 VALVE

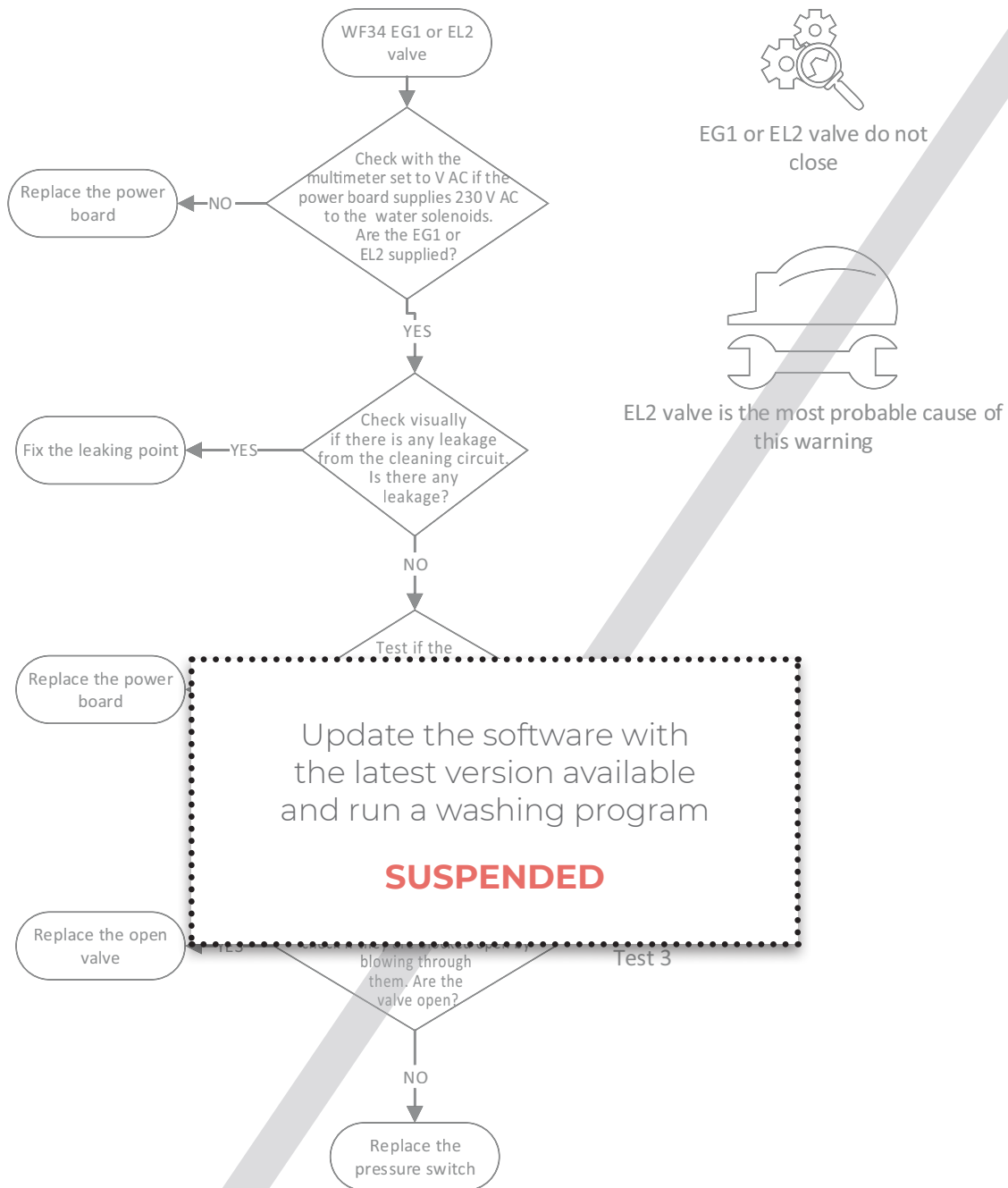

WF35 - EG1 OR EG2 OR EL2 VALVE

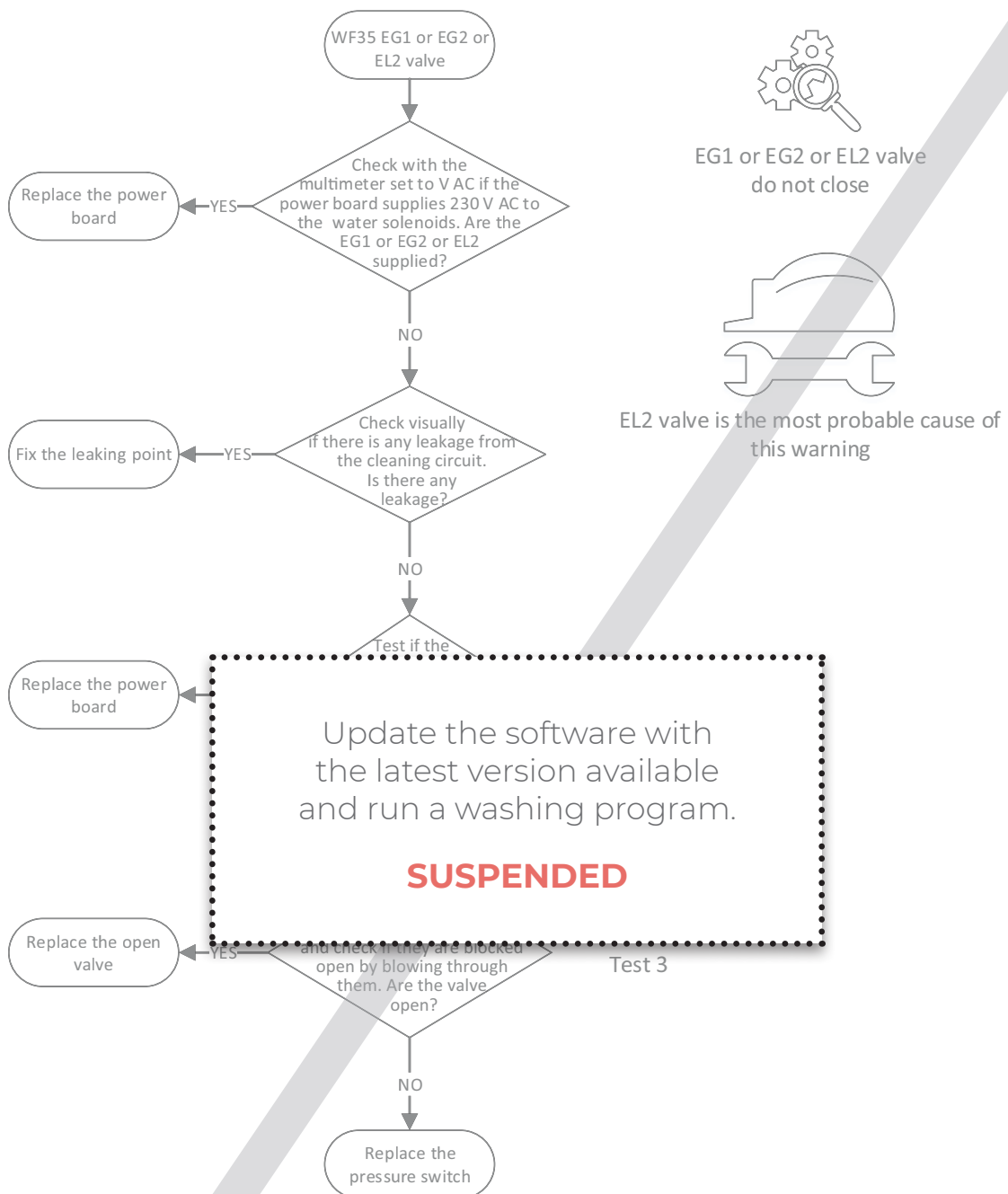

WF36 - LACK OF WATER OR EL1 OR EG1/EG2

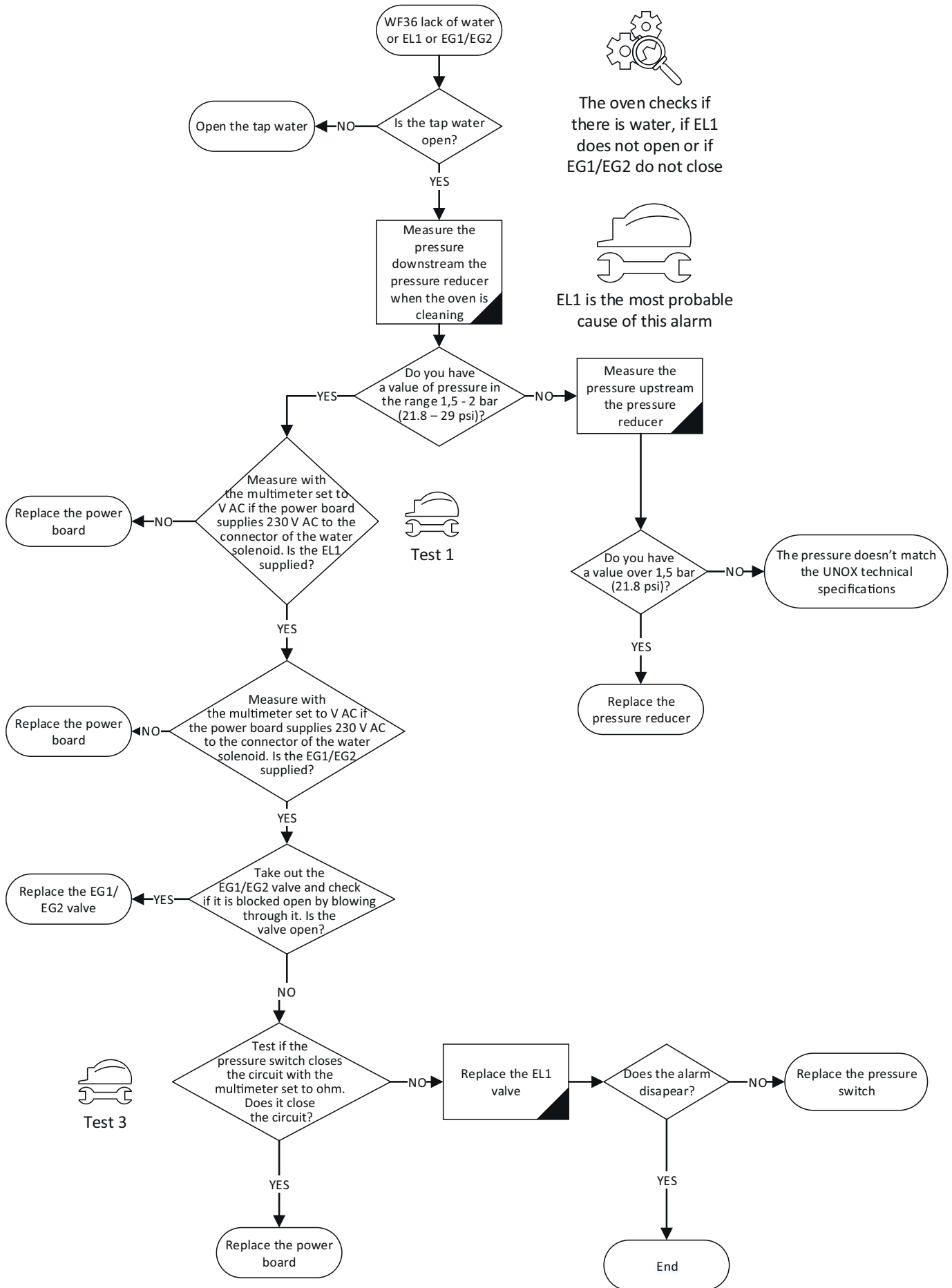

WF37 - LACK OF WATER OR EL1 OR EG1/EG2



Maybe chemical is in the cooking chamber



The oven checks if there is water, if EL1 does not open or if EG1/EG2 do not close

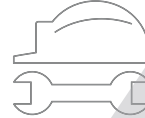

EL1 is the most probable cause of this alarm

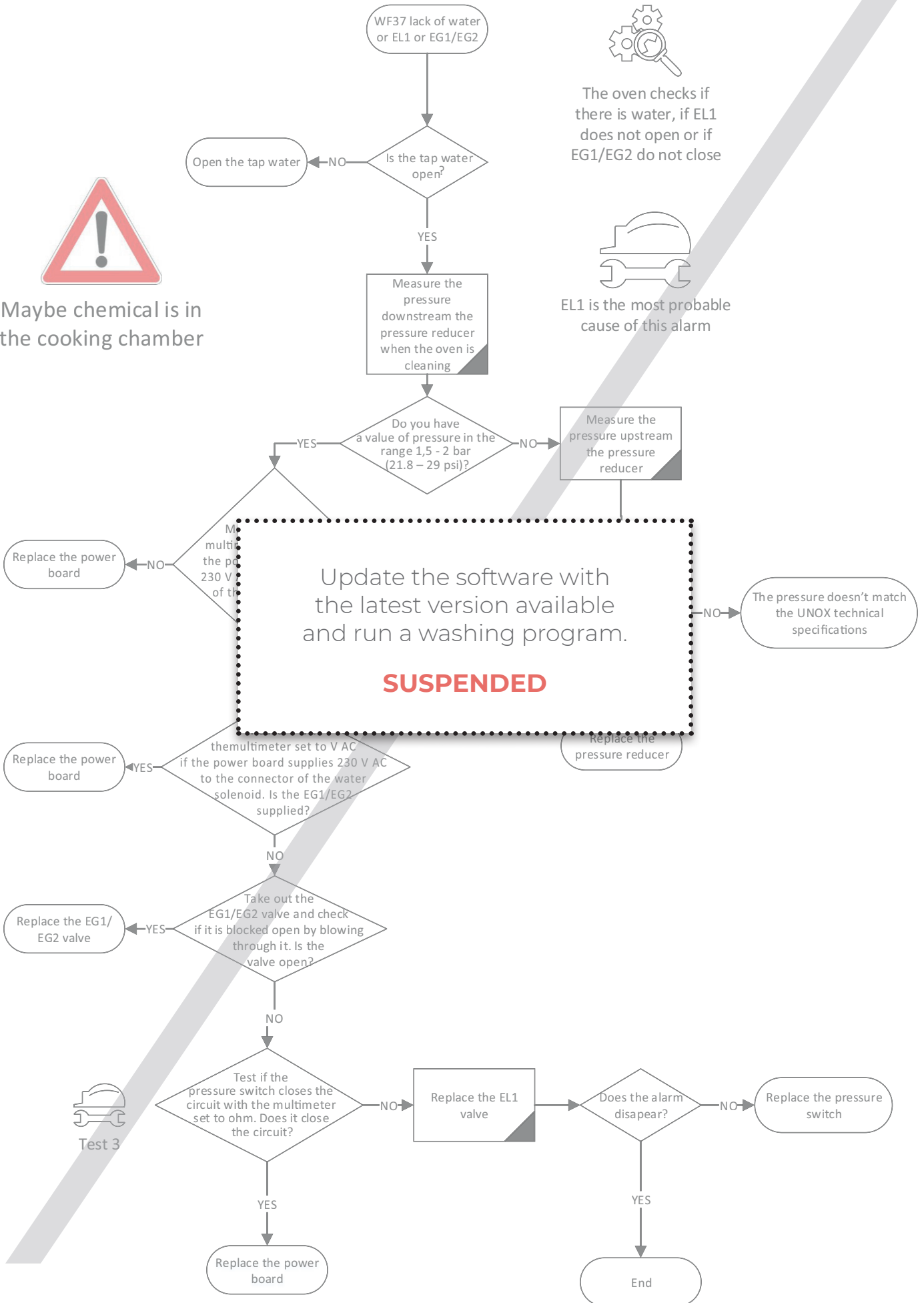

WF38 - FLAME CONTROL BOARD WARNING

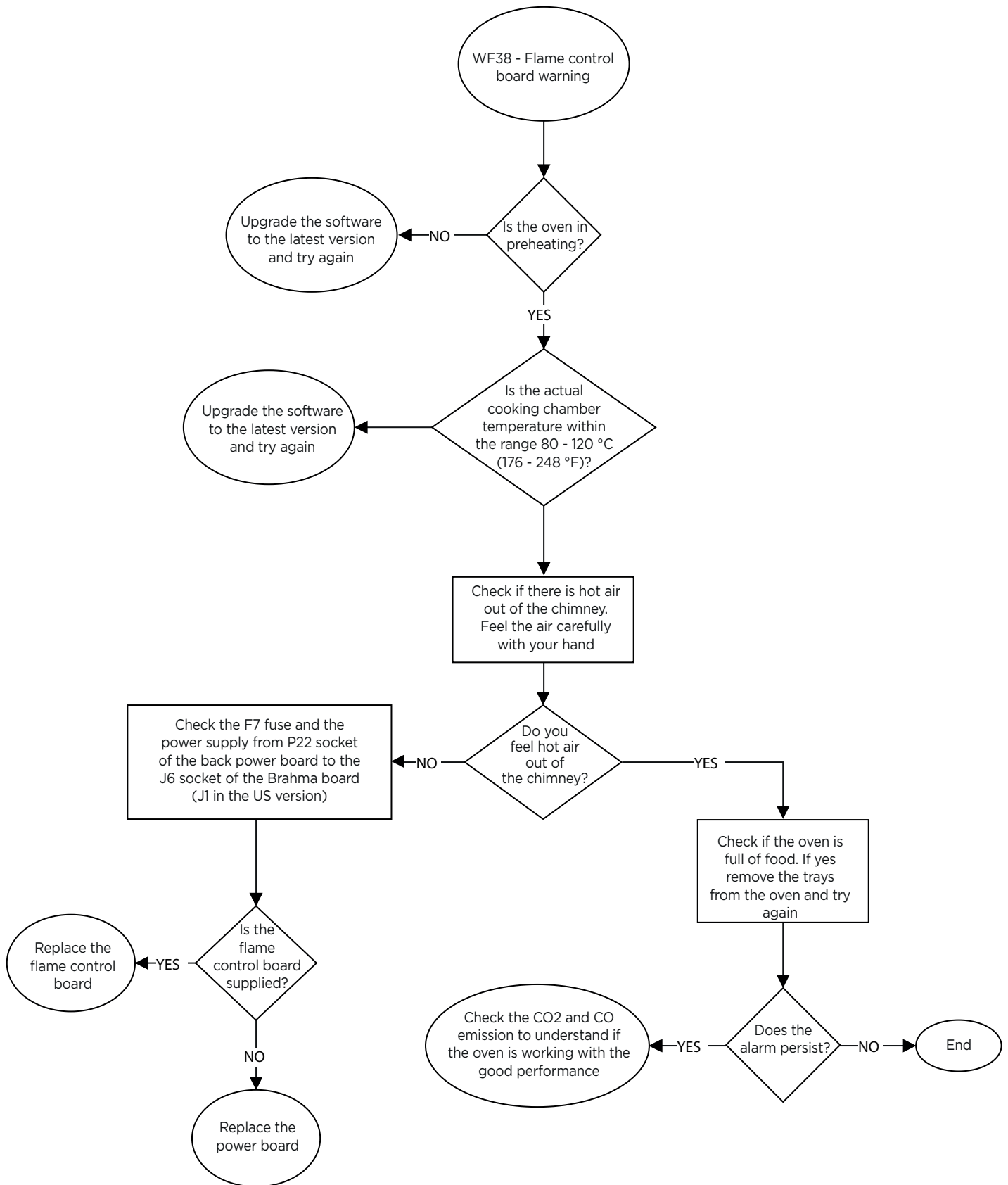

WF41 - INTERNET CONNECTION FAIL

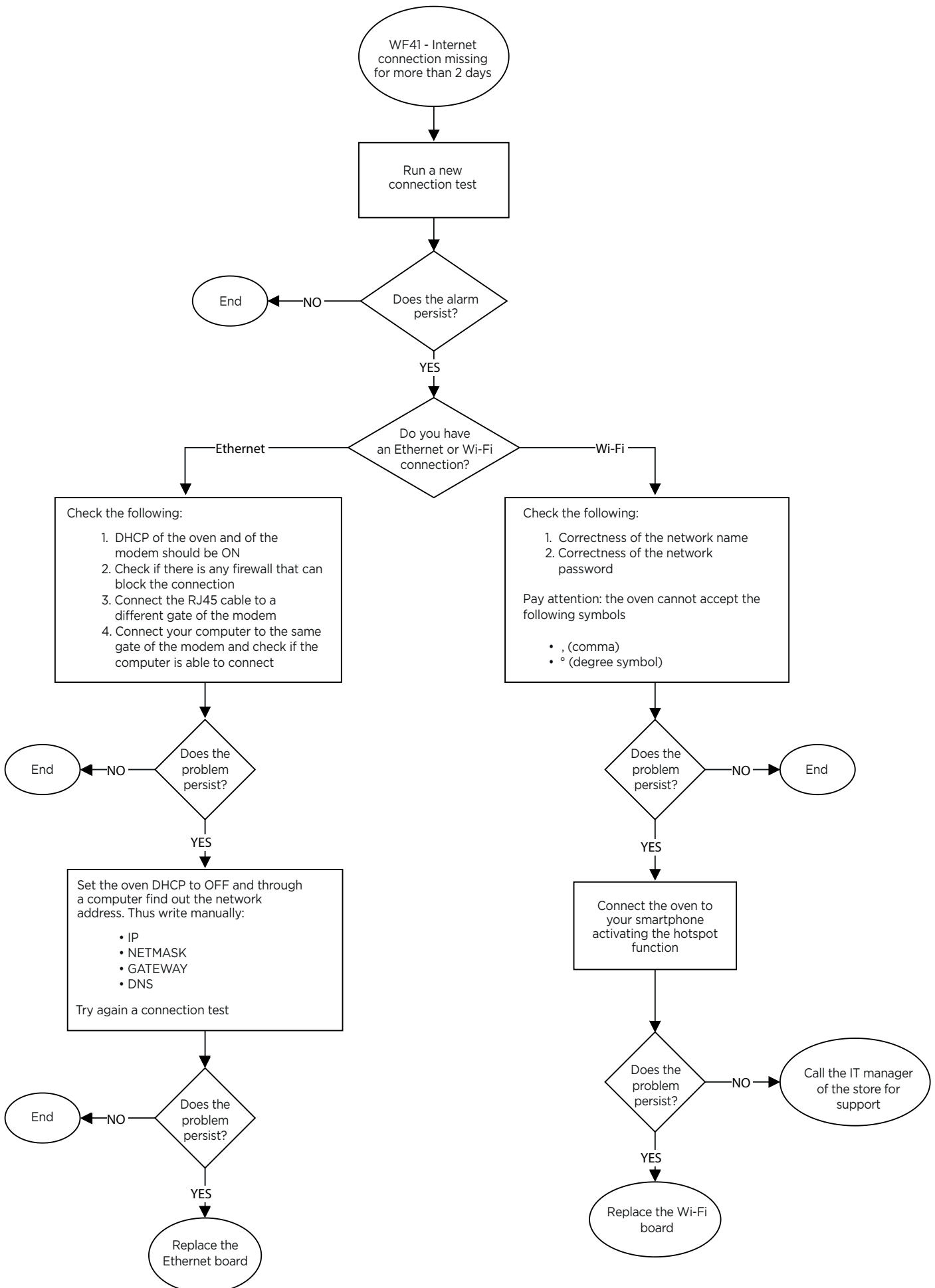

WC01 – TEMPERATURE PROBE WARNING

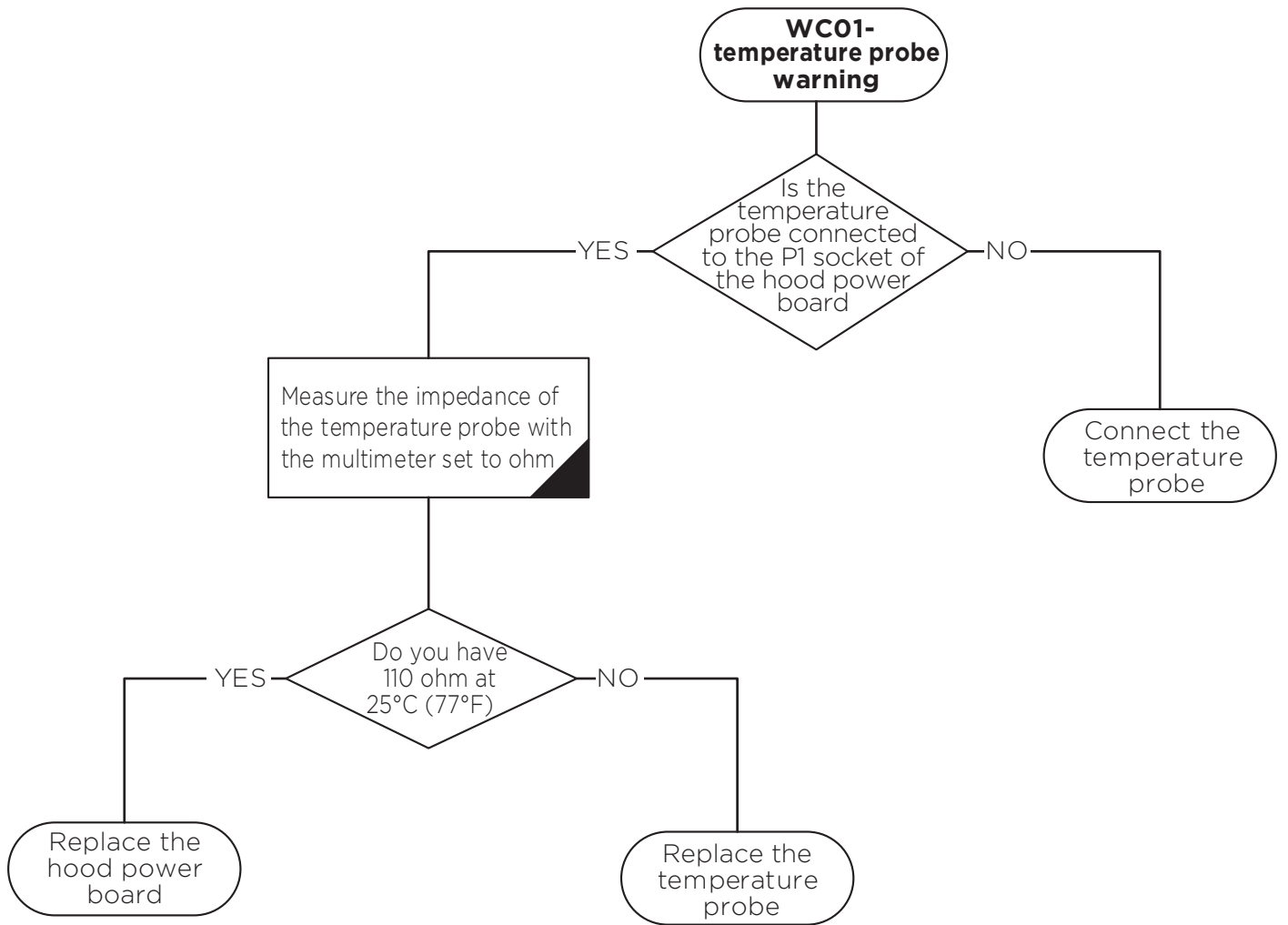

Pt100 Temperature Probe Resistance table

°C	0	1	2	3	4	5	6	7	8	9
10	103.9	104.29	104.68	105.07	105.46	105.85	106.24	106.63	107.02	107.4
20	107.79	108.18	108.57	108.96	109.35	109.73	110.12	110.51	110.9	111.28
30	111.67	112.06	112.45	112.83	113.22	113.61	113.99	114.38	114.77	115.15
40	115.54	115.93	116.31	116.7	117.08	117.47	117.85	118.24	118.62	119.01
50	119.4	119.78	120.16	120.55	120.93	121.32	121.7	122.09	122.47	122.86
60	123.24	123.62	124.01	124.39	124.77	125.16	125.54	125.92	126.31	126.69
70	127.07	127.45	127.84	128.22	128.6	128.98	129.37	129.75	130.13	130.51
80	130.89	131.27	131.66	132.04	132.42	132.8	133.18	133.56	133.94	134.32
90	134.7	135.08	135.46	135.84	136.22	136.6	136.98	137.36	137.74	138.12
100	138.5	138.88	139.26	139.64	140.02	140.39	140.77	141.15	141.53	141.91
110	142.29	142.66	143.04	143.42	143.8	144.17	144.55	144.93	145.31	145.68
120	146.06	146.44	146.81	147.19	147.57	147.94	148.32	148.7	149.07	149.45
130	149.82	150.2	150.57	150.95	151.33	151.7	152.08	152.45	152.83	153.2
140	153.58	153.95	154.32	154.7	155.07	155.45	155.82	156.19	156.57	156.94
150	157.31	157.69	158.06	158.43	158.81	159.18	159.55	159.93	160.3	160.67
160	161.04	161.42	161.79	162.16	162.53	162.9	163.27	163.65	164.02	164.39
170	164.76	165.13	165.5	165.87	166.24	166.61	166.98	167.35	167.72	168.09
180	168.46	168.83	169.2	169.57	169.94	170.31	170.68	171.05	171.42	171.79
190	172.16	172.53	172.9	173.26	173.63	174	174.37	174.74	175.1	175.47
200	175.84	176.21	176.57	176.94	177.31	177.68	178.04	178.41	178.78	179.14
210	179.51	179.88	180.24	180.61	180.97	181.34	181.71	182.07	182.44	182.8
220	183.17	183.53	183.9	184.26	184.63	184.99	185.36	185.72	186.09	186.45
230	186.82	187.18	187.54	187.91	188.27	188.63	189	189.36	189.72	190.09
240	190.45	190.81	191.18	191.54	191.9	192.26	192.63	192.99	193.35	193.71
250	194.07	194.44	194.8	195.16	195.52	195.88	196.24	196.6	196.96	197.33
260	197.69	198.05	198.41	198.77	199.13	199.49	199.85	200.21	200.57	200.93

WC02 – POWER BOARD OVER TEMPERATURE

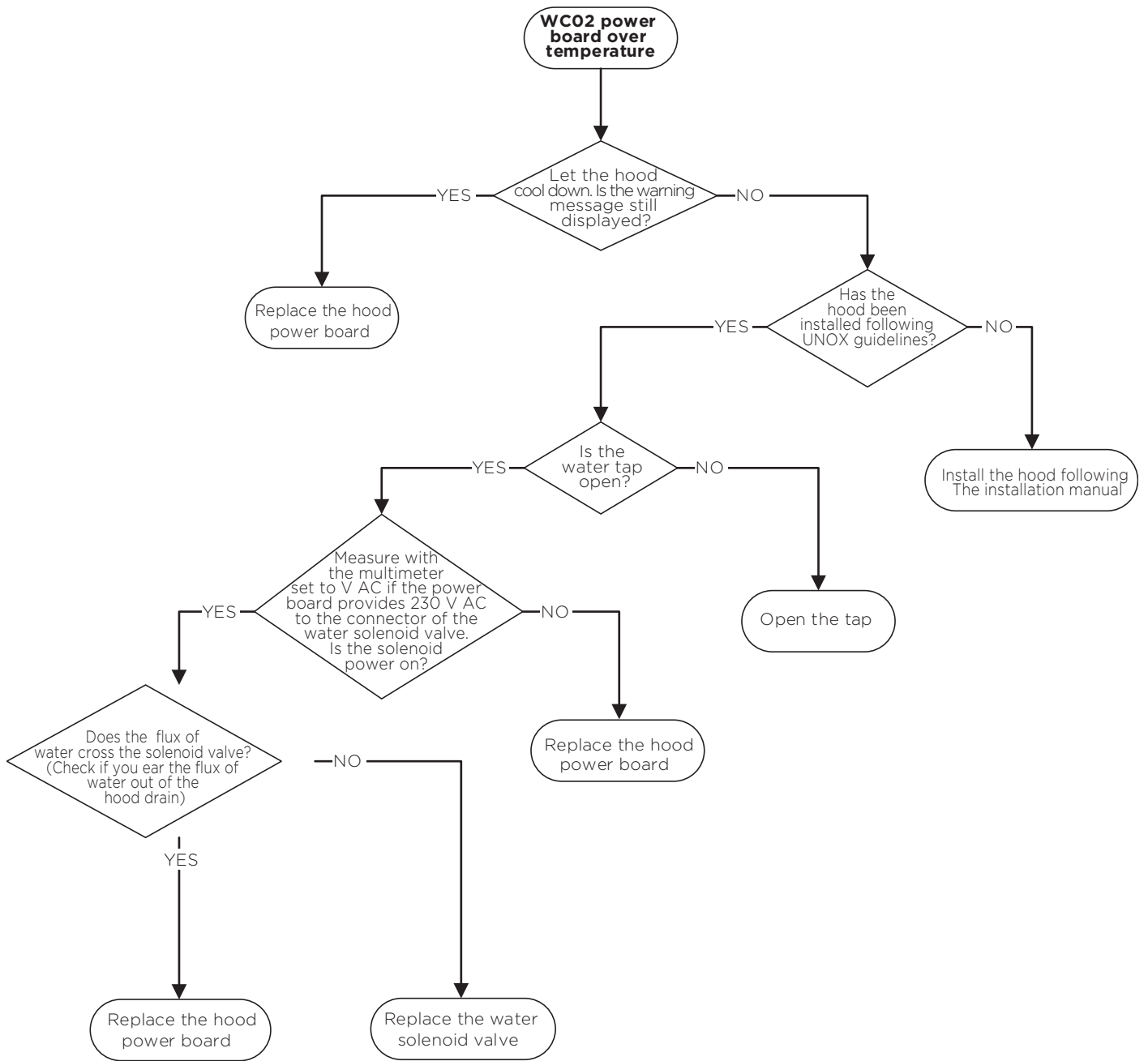

WC05 – FUMES TEMPERATURE WARNING

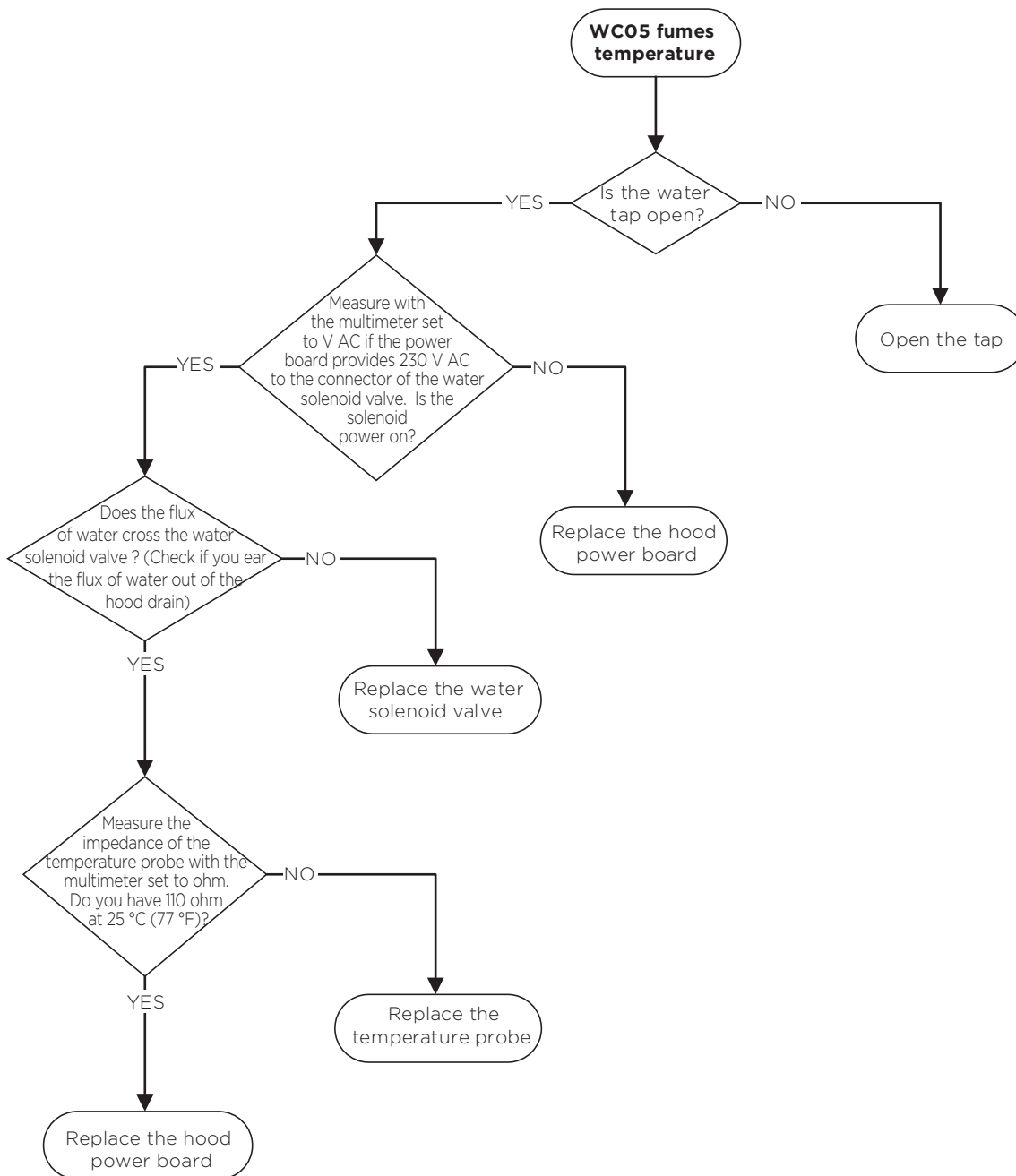

WC06 – LACK OF POWER WARNING

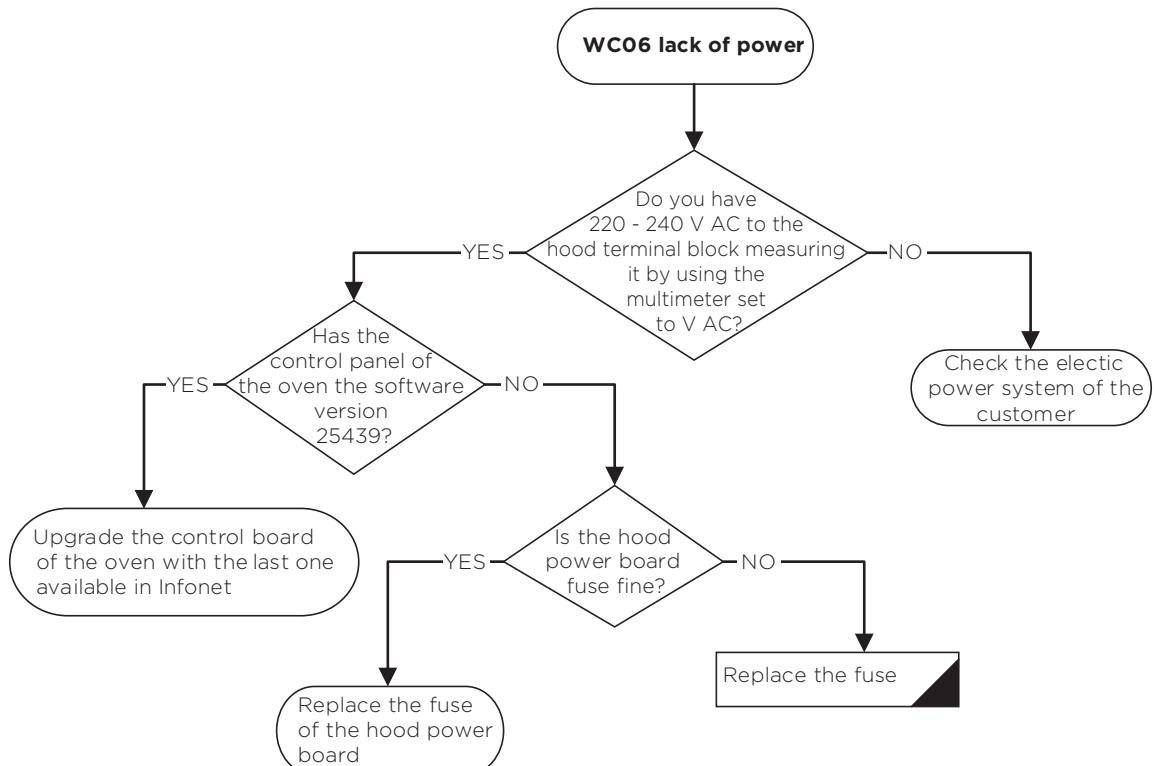

WC07 – LACK OF COMMUNICATION WARNING

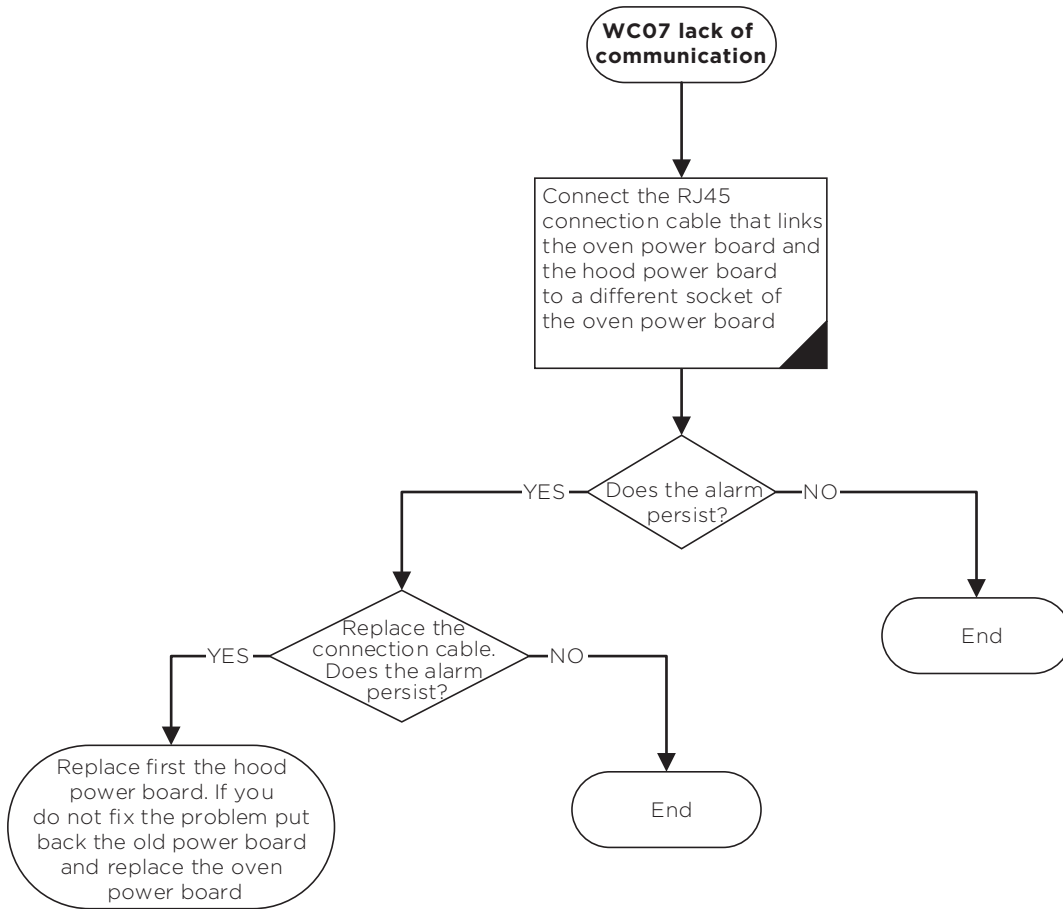

AS01-AS02- FLOOR OR CEILING SAFETY THERMOSTAT ALARM

Starting from s/n 2017D0025535, a protection shield for covering the bottom safety thermostat has been introduced to reduce the negative effect of the current position, avoiding the AS01 alarm when the temperature is set to the maximum value.

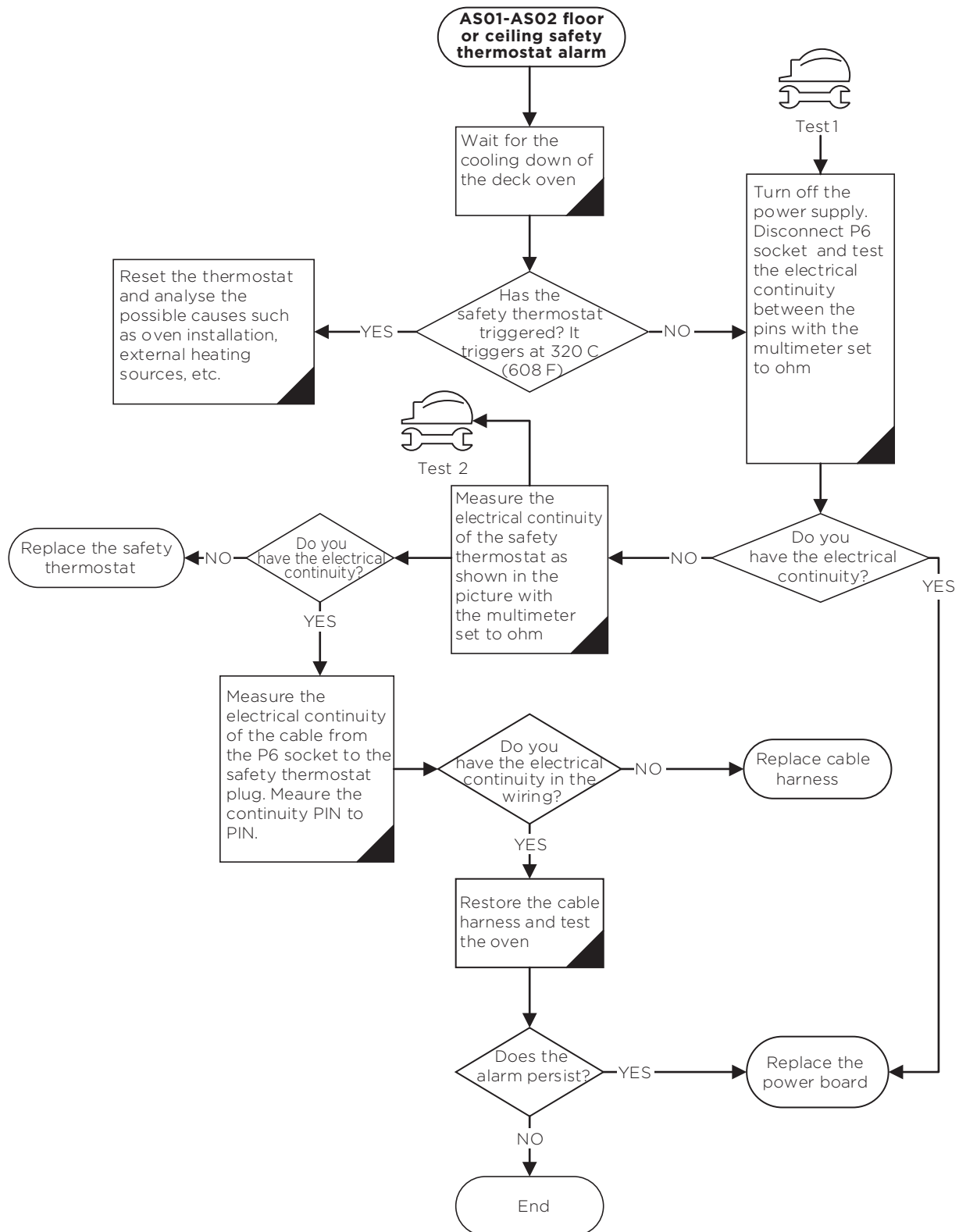

AS03 - LACK OF COMMUNICATION ALARM

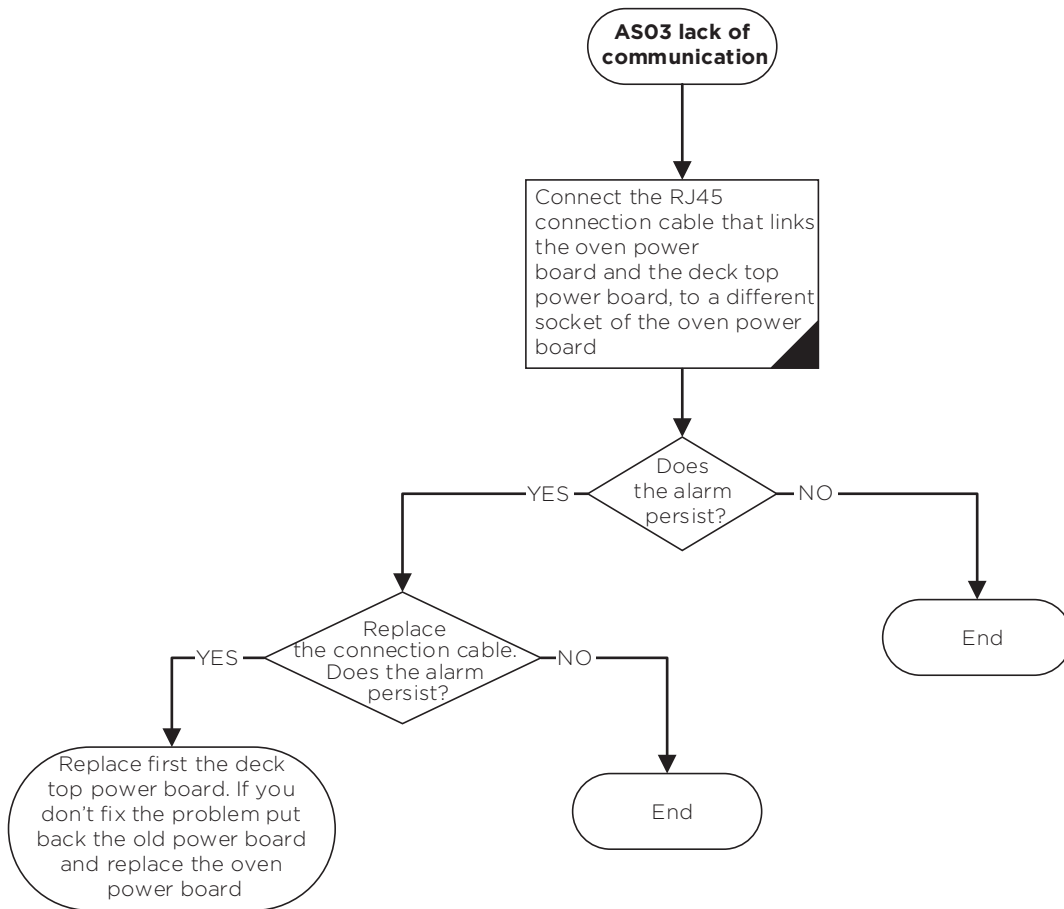

AS04-AS05 - FLOOR/CEILING TEMPERATURE PROBE ALARM

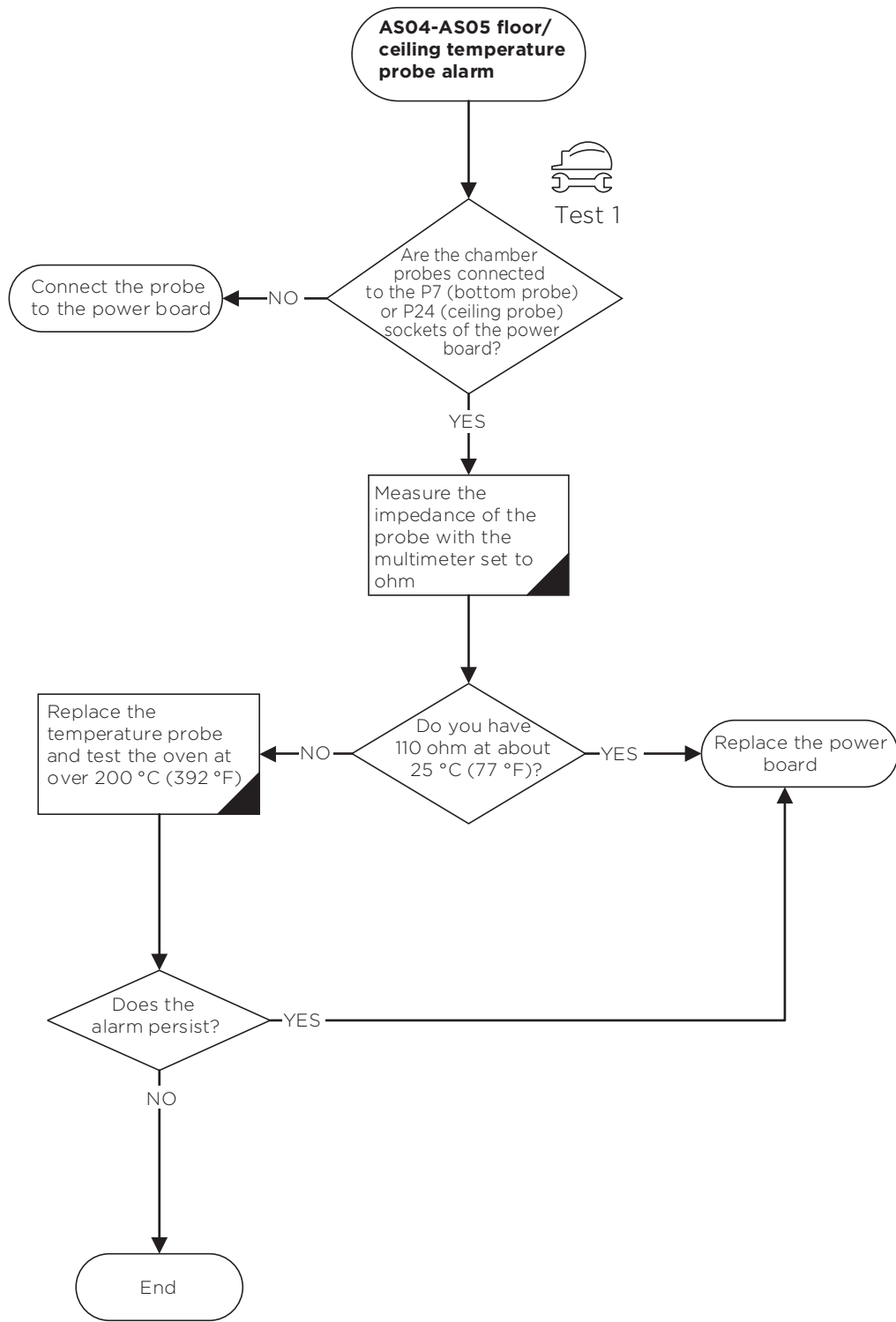

WS01 - POWER BOARD OVER HEATING WARNING

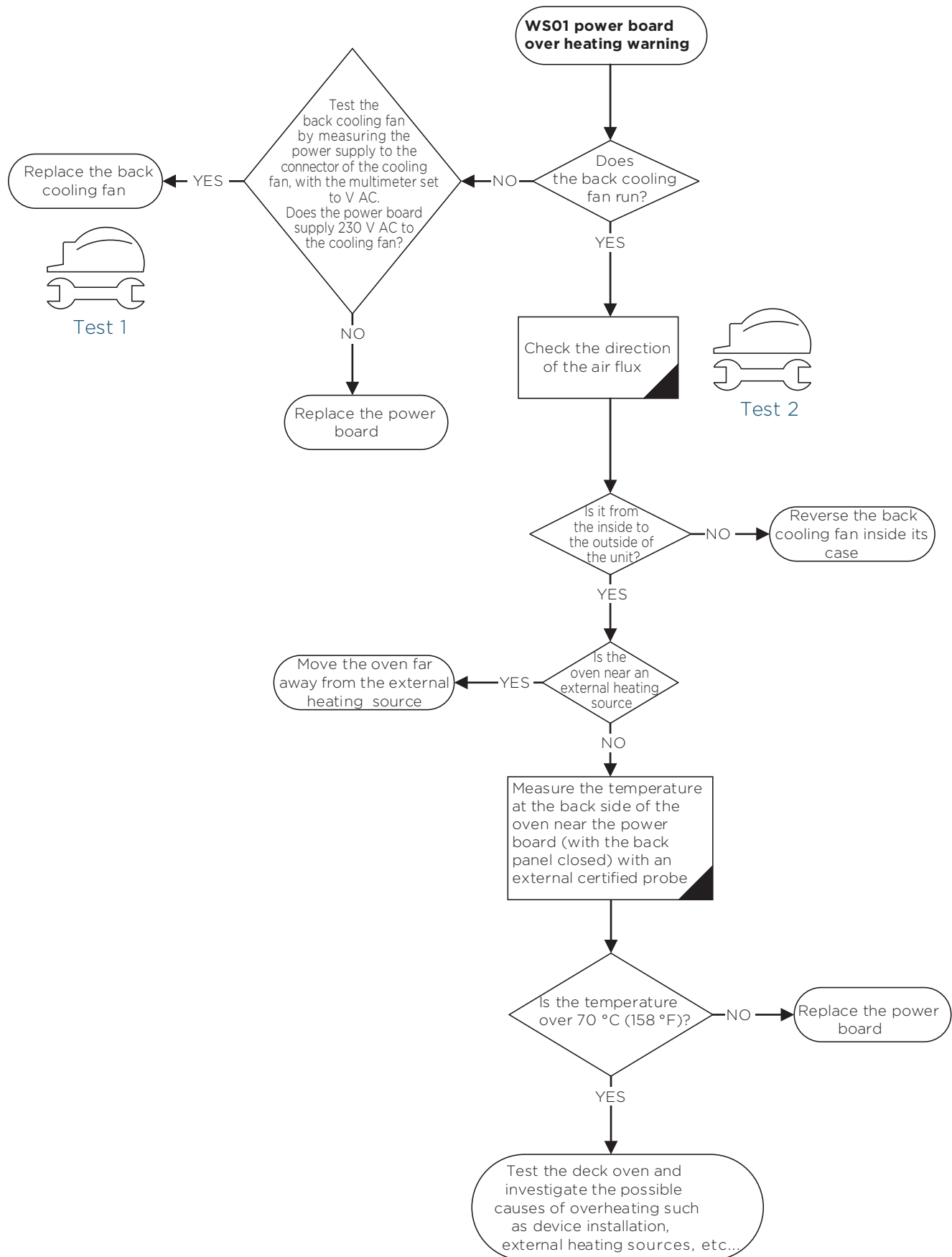

AL01-AL04 - CHAMBER/RESISTOR TEMPERATURE PROBE ALARM

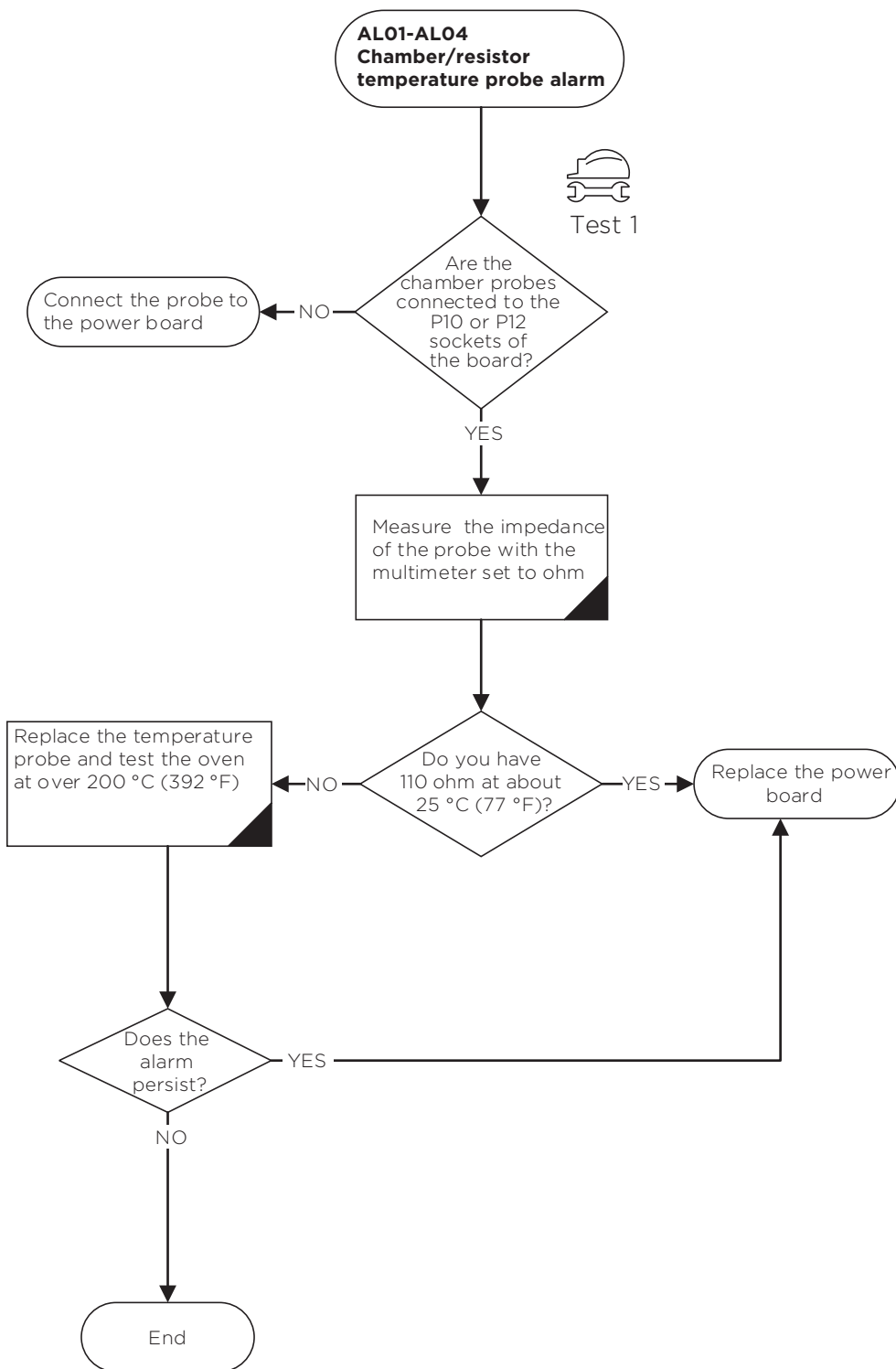

AL02 - LACK OF COMMUNICATION ALARM

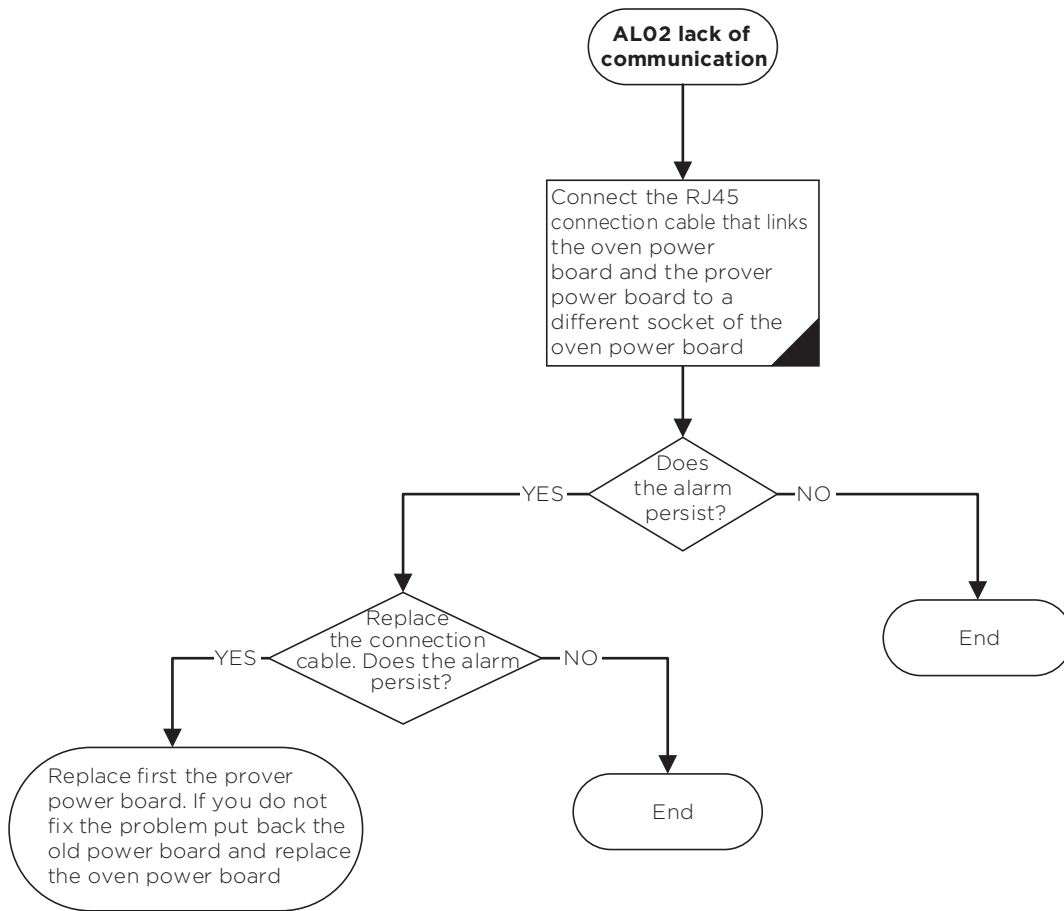

AL03 - LACK OF POWER ALARM

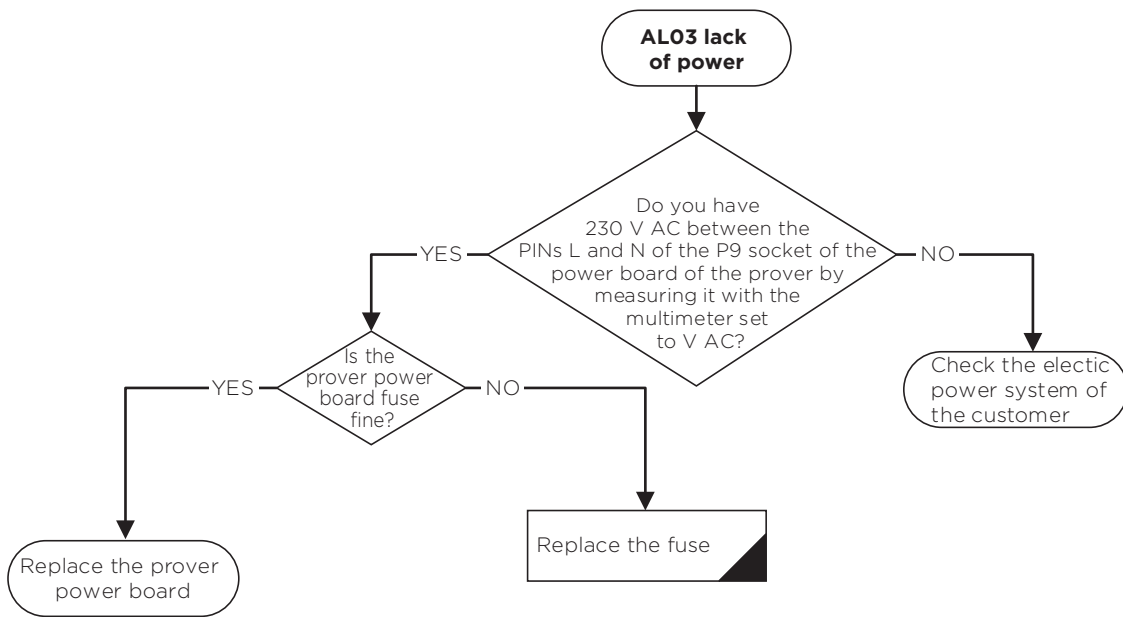

WL01 - HUMIDITY PROBE ALARM

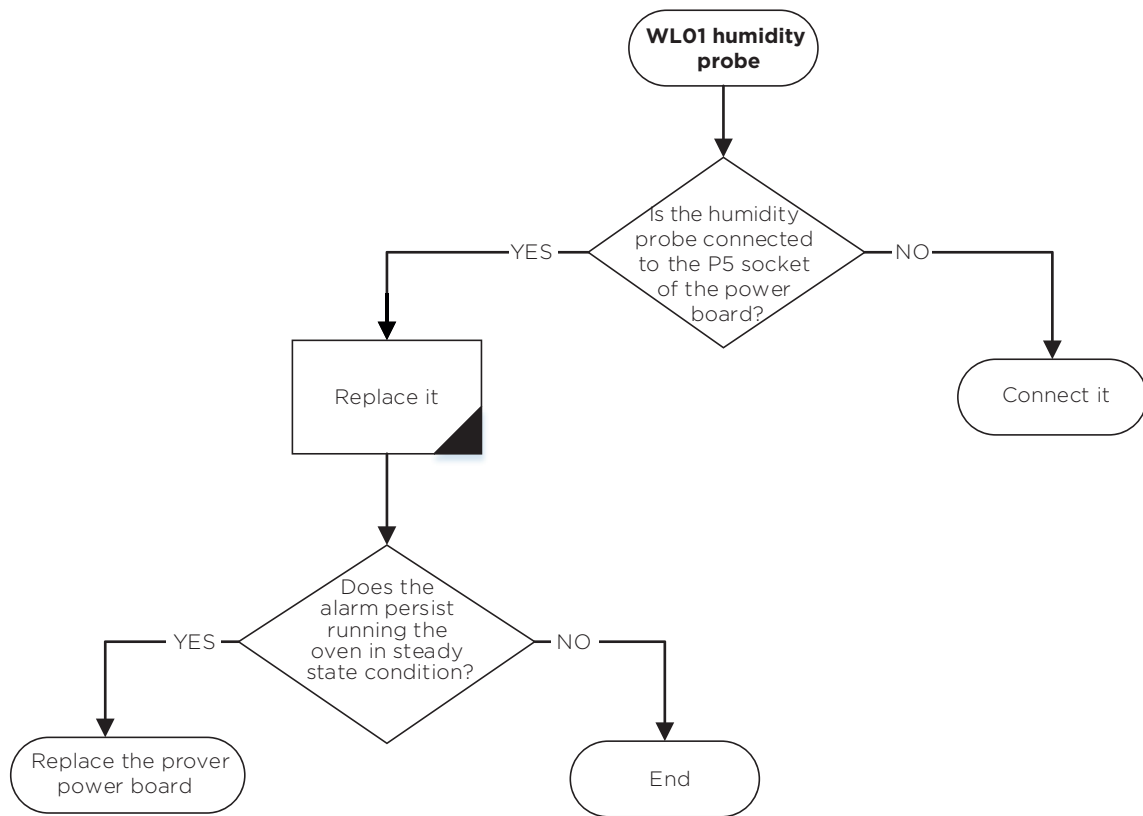

WL02 - POWER BOARD OVER TEMPERATURE ALARM

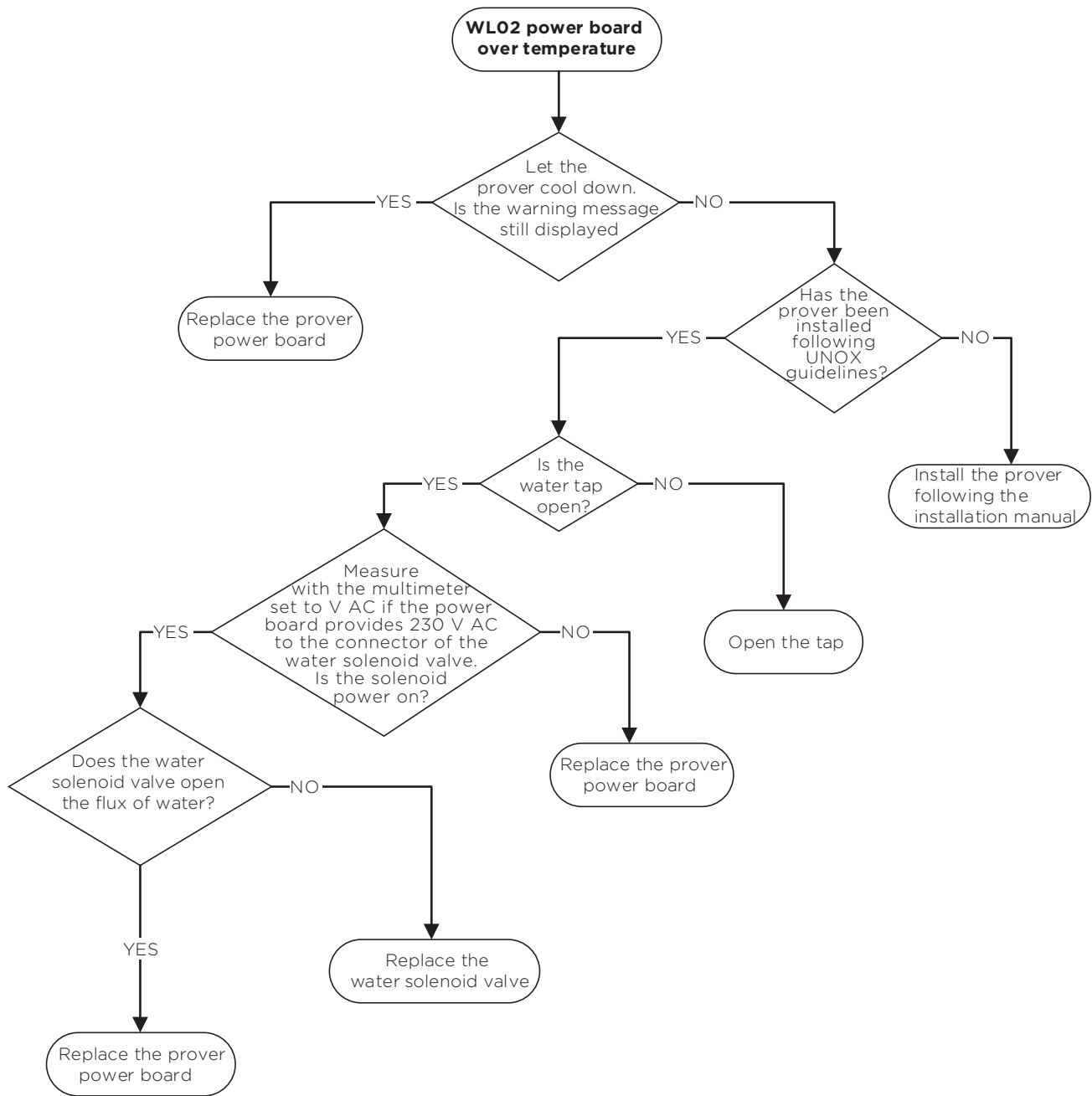

AM01 - CHAMBER TEMPERATURE PROBE ALARM

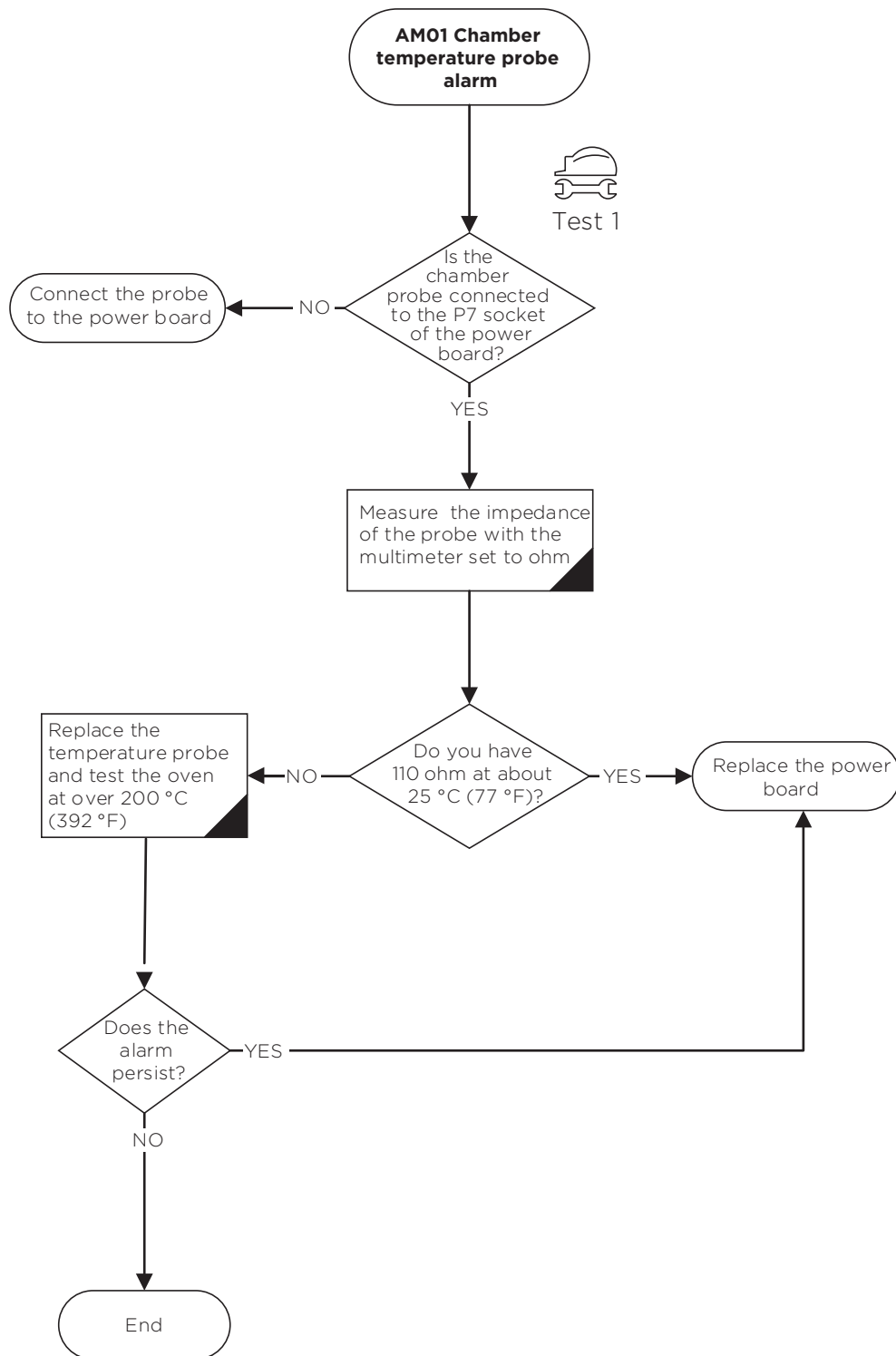

AM02 - LACK OF COMMUNICATION

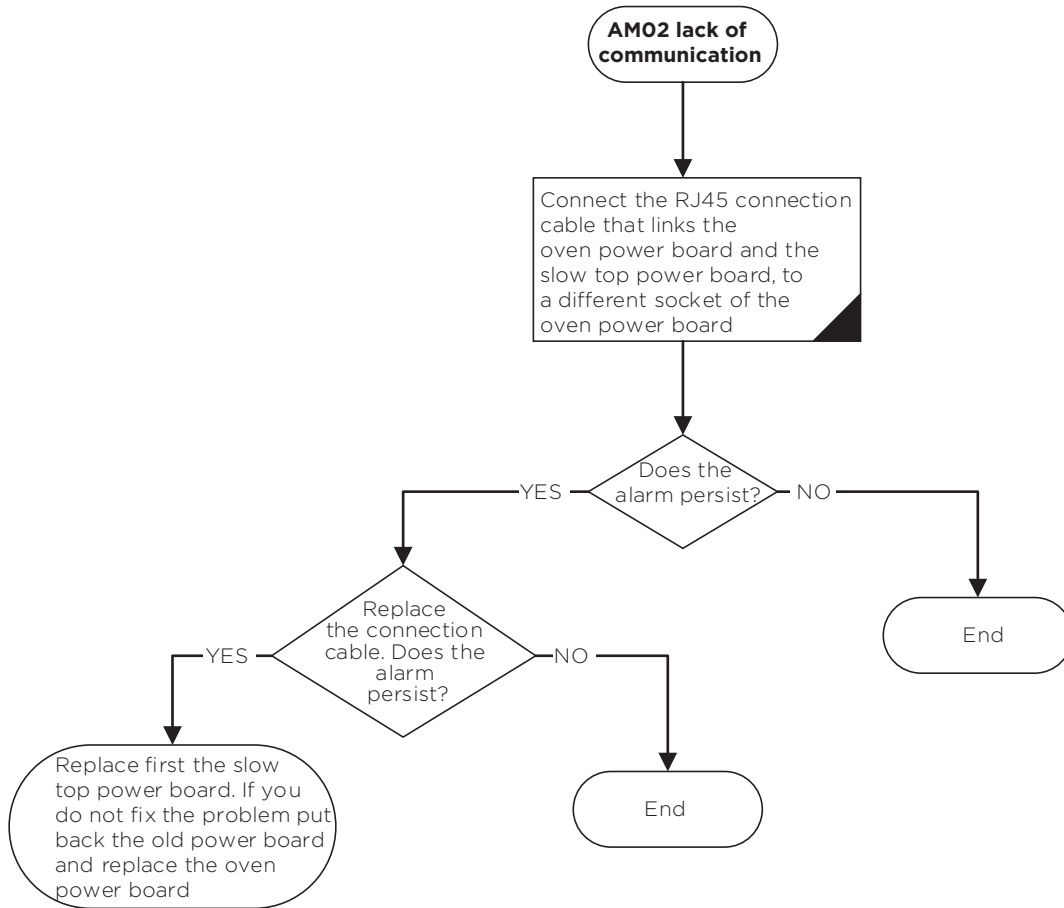

AM03 - SAFETY THERMOSTAT ALARM

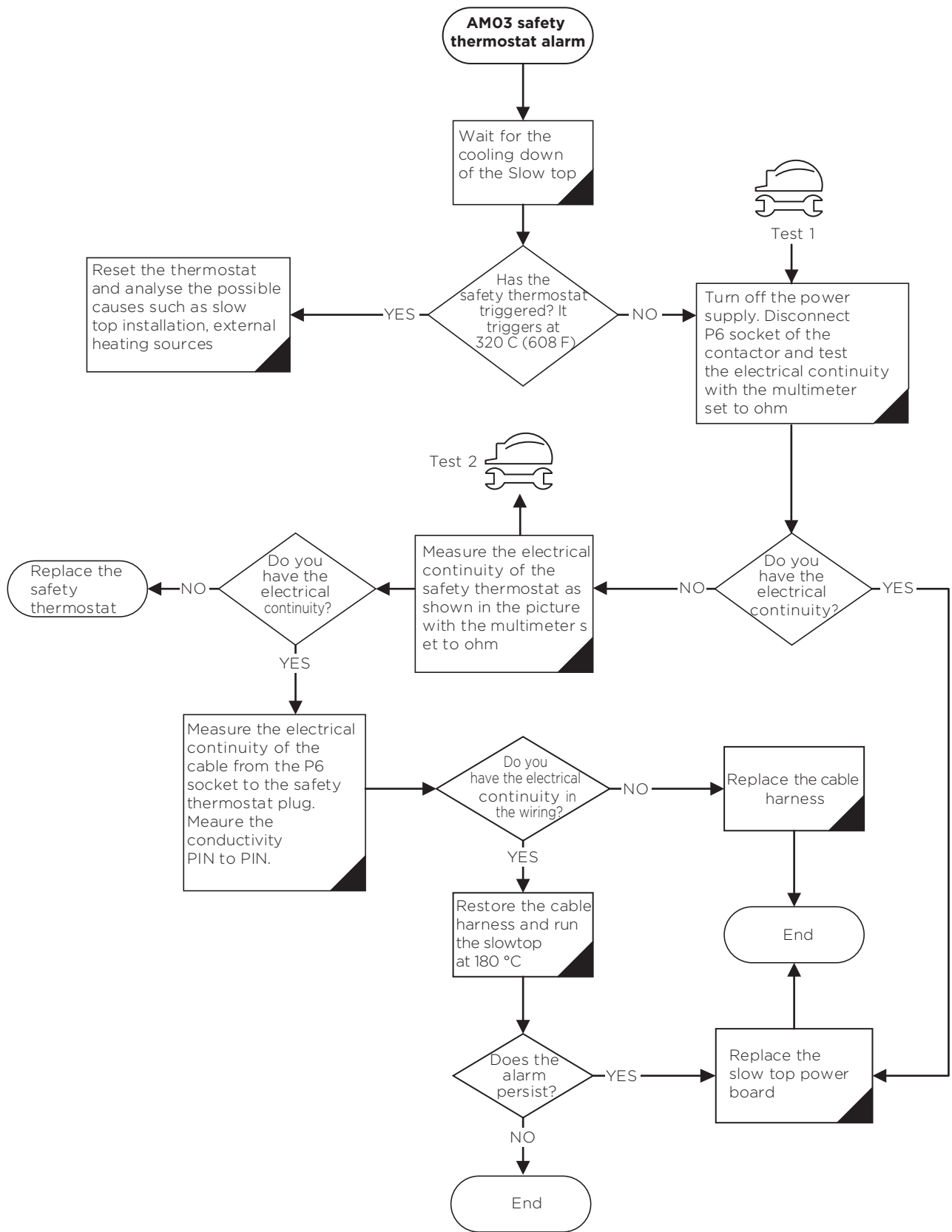

AM04 - MOTOR THERMAL PROTECTION ALARM (T > 150 °C/302 °F)

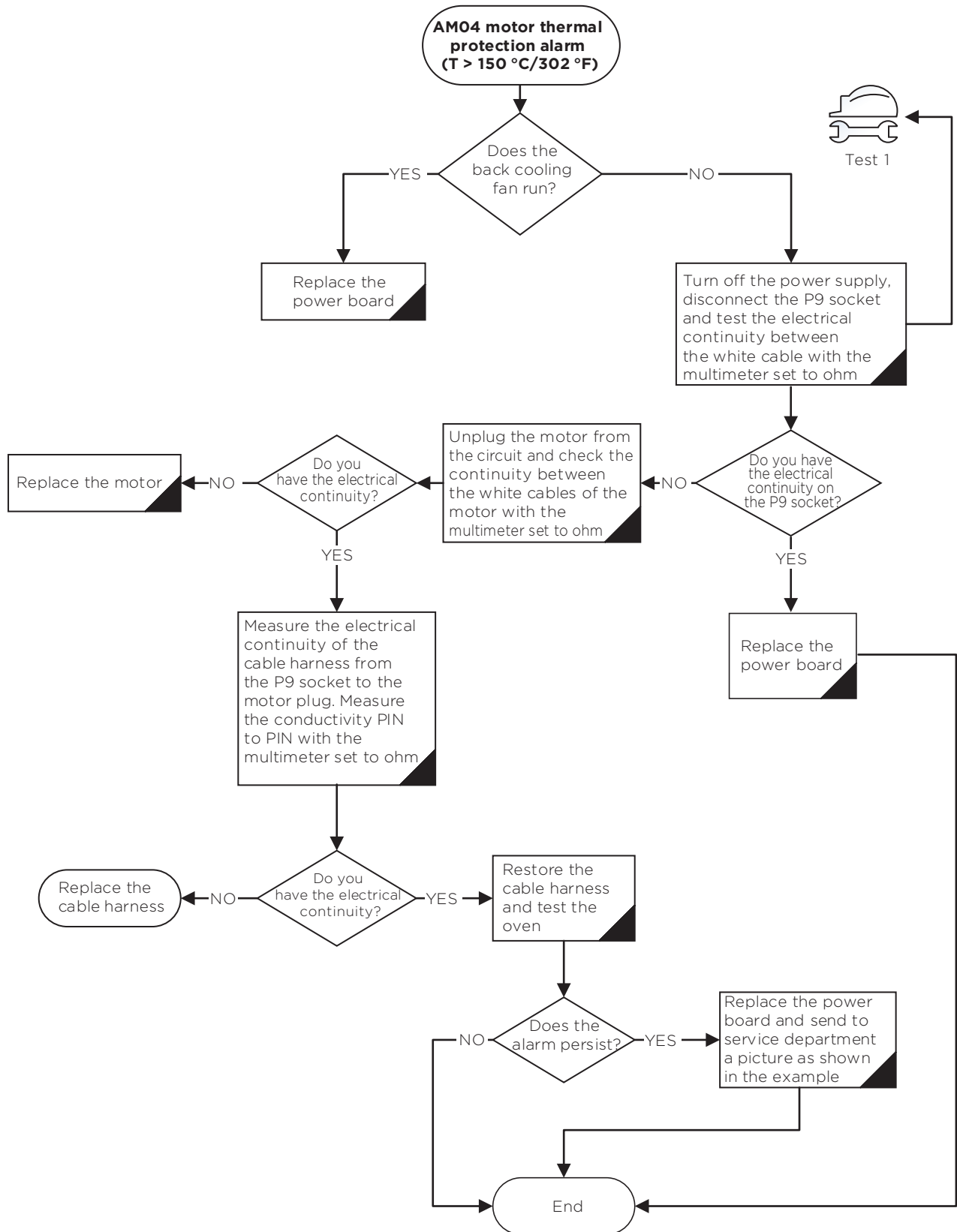

WM02 - POWER BOARD OVER HEATING WARNING

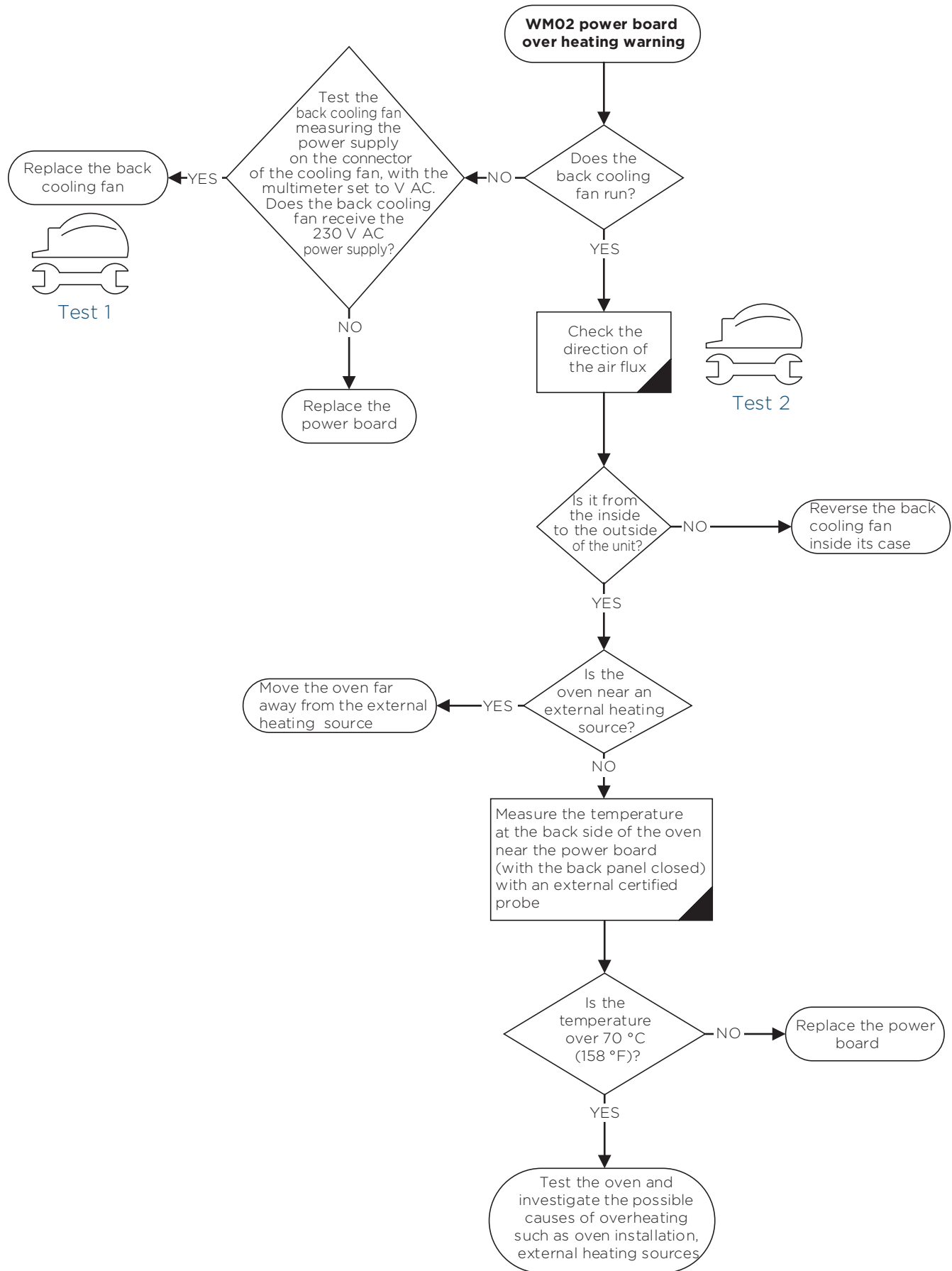

WM03 - CORE PROBE WARNING

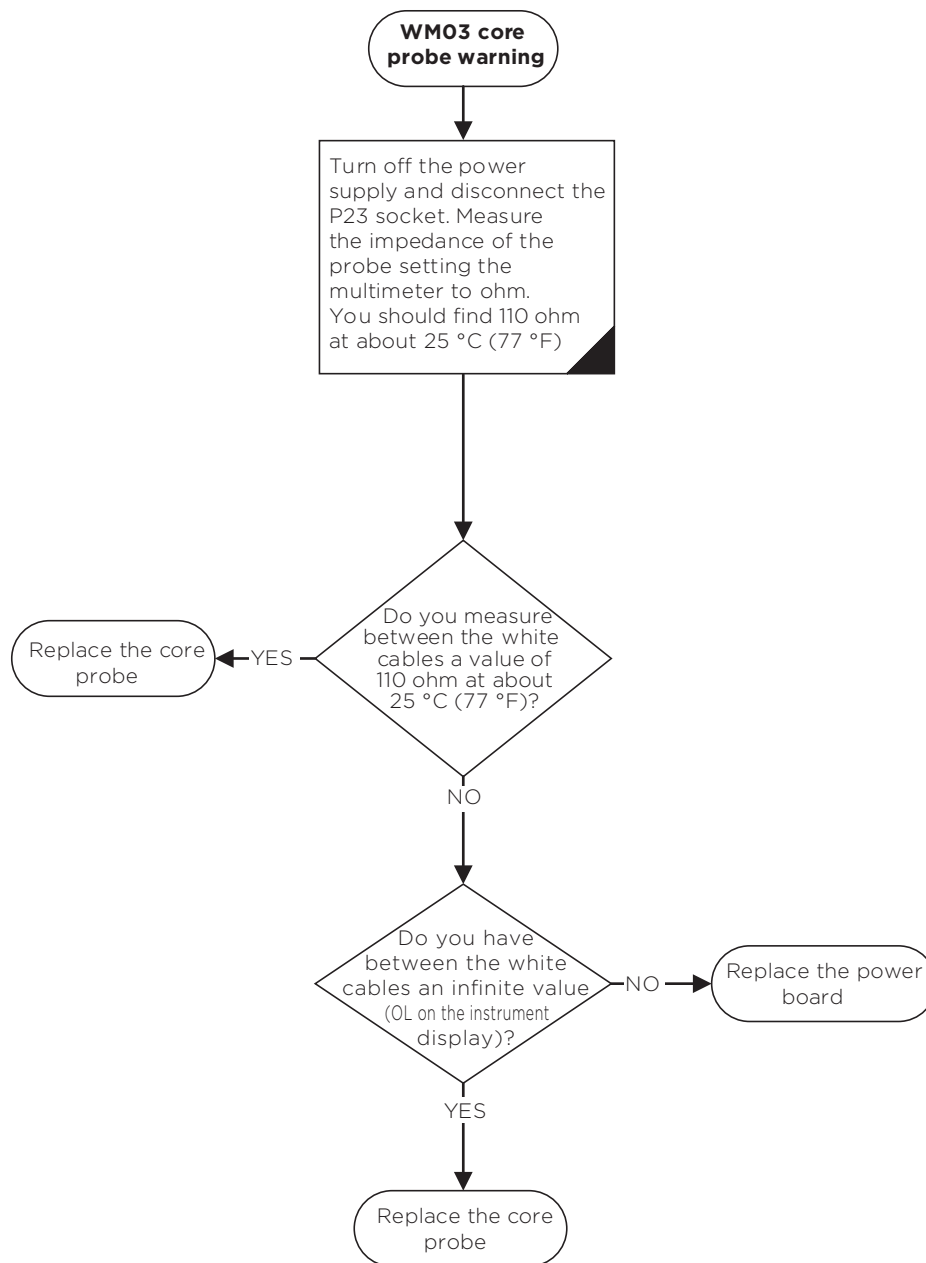

Non alarm problems

Check the following point if:

Symptom	Problem	Solution
The oven does not turn on	Power board damaged. The power board does not supply 230 V AC to the primary transformer	Measure the voltage using a multimeter set to VAC of the P1 socket between the PIN labelled NF and LF of the power board. If the power board does not provide 230 VAC to the transformer replace the power board.
	Transformer shorted	If the power board supplies 230 V AC to the transformer and the oven does not turn on replace the transformer.
	F2 fuse of the power board blown	Check if the primary of the transformer is shorted by measuring the electrical continuity between primary and secondary turns with the multimeter set to ohm. If the transformer works properly you should not have electrical continuity <ul style="list-style-type: none"> ■ In case the transformer is damaged, replace it and then replace the fuse (size: 2A - 250 V type: Fast Acting). Verify that phase and neutral are not switched; ■ If the primary transformer is fine, replace the power board.
	F4 fuse of the power board blown	Disconnect the low voltage loads sockets: P21, P30, P20, P19, P18, P17, P16, P15, P14, P28, P32, P13, P12 P11, P10, P9, P8 and replace the fuse (5A – 250V Time Delay), connect the above sockets one by one until you find the shorted component, and then replace it. If the fuse continues to blow replace the power board
Gas ovens does not heat. The flame icon is on the display while the motors are normally running	F7 fuse blown on the gas power board	Disconnect the P22 socket, replace the fuse (size: 2A– 250 V type: Fast Acting) and run the oven (T = 260 °C, t = inf): <ul style="list-style-type: none"> ■ If the fuse blows again replace the power board, otherwise connect P22 and disconnect the J2 and J3 sockets of the igniter from the Brahma flame control board and run the oven (T = 260 °C, t = inf). ■ If the fuse blows replace the flame control board, otherwise at least one of the two igniter is shorted, therefore replace the double igniters upgrade kit, code XRF011
	Gas Power board damaged	Measure the voltage across the P22 socket between the two PINs labelled 'NGAS' and 'FGAS' with the multimeter set to VAC: <ul style="list-style-type: none"> ■ If you do not have power (220-240 V AC) replace the board; if you have power (220-240 V AC), measure it between PIN 8 and 10 of the J5 socket of the Brahma flame control board with the multimeter set to VAC. ■ If there is not power supply, replace the Brahma flame control board, otherwise replace the power board.
	F9 fuse of the power board blown	Disconnect the blower from P29 or P27 socket, replace it and test the oven. <ul style="list-style-type: none"> ■ If the fuse blows again, replace the power board. Otherwise connect the blower and test the oven ■ If the fuse blows, replace the blower
The ground fault circuit interrupter (GFCI) triggered	When you turn on the power supply the GFCI triggers immediately	The transformer has an electrical leakage, and needs to be replaced.

Symptom	Problem	Solution
The ground fault circuit interrupter (GFCI) triggeredThe circuit breaker triggered	When the control board reboot the GFCI triggers	The back-cooling fan supplied at 230 V AC has an electrical leakage, and needs to be replaced.
	When the oven is running a cooking or a cleaning program the GFCI triggers	<p>Proceed as follow: Set a cooking program, t = inf, T = 30 °C, v = 4 and run the oven.</p> <ul style="list-style-type: none"> ■ If the GFCI triggers, it means that at least one motor has an electrical leakage. Test between the black and red wire of the motor socket and the body of the oven with the multimeter set to ohm if there is a ground fault and eventually replace the damaged motor; ■ If the GFCI does not trigger set T = 260 °C and run the oven.If the GFCI triggers it means that at least one heating element has an electrical leakage. Test between the cable harnesses of each connector of the heating elements (3 turns for each element) and the ground with the multimeter set to ohm, if there is a ground fault, eventually replace the damaged heating element; <p>If you run the oven at T = 260 °C the GFCI does not trigger, set STEAM. Maxi to 100 % and run the oven.</p> <ul style="list-style-type: none"> ■ If the GFCI triggers, it means that the steam solenoid valve has an electrical leakage. Test between the cable harnesses of the solenoid valve and the ground with the multimeter set to ohm, if there is a ground fault, eventually replace the damaged solenoid valve; ■ If the GFCI does not trigger, set DRY.Maxi to 100 % and run the oven.If the GFCI triggers it means that the DRY.Maxi solenoid has an electrical leakage. <p>Test between the cable harnesses of the DRY.Maxi valve and the ground with the multimeter set to ohm, if there is a ground fault, eventually replace the damaged valve;</p> <ul style="list-style-type: none"> ■ If the GFCI does not trigger, run a cleaning cycle.If the GFCI triggers immediately it means that one of the water solenoid valve has an electrical leakage. Test between the cable harnesses of the solenoid valve and the ground, if there is a ground fault with the multimeter set to ohm, replace the damaged solenoid valve; ■ If the GFCI triggers during the pump loading it means that the detergent pump has an electrical leakage, and needs to be replaced.
The circuit breaker triggered	When the control board reboots the circuit breaker triggers	The back-cooling fan supplied at 230 V AC is shorted, therefore replace back-cooling fan
	When the oven is running a cooking or a washing program the circuit breaker triggers	<p>Set a cooking program, t = inf, T = 30 °C, v = 4 and run the oven.</p> <ul style="list-style-type: none"> ■ If the circuit breaker triggers, it means that at least one motor is shorted. Test between the black and red wire of the motor socket if there is electrical continuity with the multimeter set to ohm and eventually replace the motor with the fault; ■ If the circuit breaker does not trigger set T = 260 °C and run the oven. ■ If the circuit breaker triggers it means that at least one heating element is shorted. Test between the cable harness of the heating element turns if there is electrical continuity with the multimeter set to ohm, eventually replace the damaged heating element; <p>If with T = 260 °C the circuit breaker does not trigger, set STEAM.Maxi to 100 % and run the oven.</p> <ul style="list-style-type: none"> ■ If the circuit breaker triggers it means that the steam solenoid valve is shorted. Test between the cable harnesses of the solenoid valve if there is electrical continuity with the multimeter set to ohm, eventually replace the faulty solenoid valve; ■ If the circuit breaker does not trigger, set DRY.Maxi to 100 % and run the oven. ■ If the circuit breaker triggers it means that the DRY.Maxi solenoid is shorted. Test between the cable harnesses of the DRY. Maxi solenoid if there is electrical continuity with the multimeter set to ohm, eventually replace the damaged valve; <p>If the circuit breaker does not trigger, run a cleaning cycle.</p> <ul style="list-style-type: none"> ■ If the circuit breaker triggers immediately it means that one of the water solenoid valve is shorted. Test between the cable harness of the solenoid valve if there is electrical continuity with the multimeter set to ohm, eventually replace the faulty solenoid valve; ■ If the circuit breaker triggers during the pump loading it means that the detergent pump is shorted, therefore replace the pump.

Symptom	Problem	Solution
The electrical oven does not heat	A phase is missing	Try to plug the oven to another socket and run the oven. If the oven works properly call an electrician, otherwise follow the next steps
	Either the heating elements or the contactors are damaged	<p>Measure the amp consumption of the oven with the clamp meter directly on the terminal block.</p> <ul style="list-style-type: none"> ■ If the phase consumption does not match the technical data available on Infonet, check if the contactors close the circuit. If they do not close the circuit, check between A1 and A2 PIN with the multimeter set to V AC ■ If the power board supplies 230 V AC to the contactor turn. ■ If the power board does not feed the contactors replace it, otherwise replace the contactors; <p>Measure the amp consumption of each heating element turns.</p> <ul style="list-style-type: none"> ■ If you find 0 A in at least one turn replace the element
The cleaning cycle is not effective	The inlet water pressure is not enough	<p>Measure the inlet water pressure with a pressure gauge. Do you have a value within the range $1.5 < p < 6$ bar?</p> <ul style="list-style-type: none"> ■ If not, the water pressure is not in compliance with the UNOX specification ■ If yes, measure the pressure downstream the pressure reducer with a pressure gauge. Do you have a pressure equal to 2 bar? <ul style="list-style-type: none"> ■ If not, replace the pressure reducer ■ If yes, go on with the troubleshooting
	The power supply to the chemical pump is not enough	<p>Measure the power supply applied to the pump with a multimeter set to V AC. Do you have a power supply of 120 – 140 V AC?</p> <ul style="list-style-type: none"> ■ If not, replace the power board ■ If yes, go on with the troubleshooting
	The oven does not pump in the chemical	<p>Is the chemical filter free of residuals?</p> <ul style="list-style-type: none"> ■ If not, replace the filter ■ If yes, is the pipe downstream the pump free of residuals? <ul style="list-style-type: none"> ■ If not, replace the pipe ■ If yes, replace the pump
	The oven does not pump in water	<p>Is the tap water open?</p> <ul style="list-style-type: none"> ■ If not, open the tap ■ If yes, do you have power supply to the water solenoid measuring with the multimeter set to V AC? <ul style="list-style-type: none"> ■ If not, replace the power board ■ If yes, is the water pipe clogged? <ul style="list-style-type: none"> ■ If yes, clean the pipe and check the water quality according to UNOX specifications in terms of water chemical composition ■ If not, replace the water solenoid
	The end user runs the cleaning cycle with the trays inside the cooking chamber	Remove the trays from the cooking chamber before running a cleaning cycle
	The end user does not use the UNOX Det&Rinse chemical	The installation is not in compliance with the UNOX specification.
	The frequency of the cleaning cycle is not enough compared with what they cook and the cooking program frequency	Train the end user about the importance to clean the oven with the proper frequency

Symptom	Problem	Solution
The oven does not cook evenly	The P-trap is not installed or it is empty	Fill the P-trap by pouring a jar of water in the drain or install the P-trap
	The gasket is damaged	Replace the gasket
	The chimney is clogged	Clean the chimney with a metal brush
	The DRY.Maxi system is open	Set the oven to $t = \text{inf}$, $T = 100\text{ }^{\circ}\text{C}$ and 100% steam. Measure the power supply between PIN N and VENT of the P4 socket of the power board, with the multimeter set to V AC. Do you have power supply? <ul style="list-style-type: none"> ■ If yes, replace the power board ■ If not, is the DRY.Maxi valve open? <ul style="list-style-type: none"> ■ If yes, replace it ■ If not, go on with the troubleshooting
	The motors do not invert the sense of rotation	Check the setting of the parameter MAX SPEED NO INVERSION parameter. Is the speed of the motor greater than the value of the parameter? <ul style="list-style-type: none"> ■ If not, it is normal that the motors do not invert the sense of rotation. Set a higher speed and test the oven again ■ If yes, measure the resistance of the braking element with the multimeter set to ohm. Do you have $37.5\ \Omega$ and $75\ \Omega$ at each red and yellow braking element respectively? <ul style="list-style-type: none"> ■ If not, replace the braking element ■ If yes, replace the power board
	The temperature probe placed close to the fan / close to the bottom of the cooking chamber is not calibrated	If you measure a difference lower or equal of $5\text{ }^{\circ}\text{C}$, between the real temperature of the cooking chamber and the temperature set, with a calibrated temperature probe placed close to the one installed close to the fan guard bottom side of the cooking chamber, you can apply an OFFSET. See the section "MIND.Maps™ Service and User Menu" to know how to apply the offset. Therefore, if $T_{\text{set}} - T_{\text{chamber}} = +3.1\text{ }^{\circ}\text{C}$ (for instance $T_{\text{set}} = 180\text{ }^{\circ}\text{C}$ and $T_{\text{chamber}} = 176,9\text{ }^{\circ}\text{C}$) you should set -31 in the back/bottom probe offset to compensate. Thus $0.1\text{ }^{\circ}\text{C}$ equals to 1 in scale of values.
	The temperature probes are switched or damaged or the power board is defective	Measure if the temperature probe placed close to the fan bottom side of the cooking chamber, is connected to the P19-CMB1 socket of the power board, while the temperature probe placed close to the door or close to the ceiling of the cooking cabinet, is connected to the P16-CMB2 socket of the power board. Are the temperature probes connected correctly? <ul style="list-style-type: none"> ■ If not, switch the connection on the powerboard ■ If yes, measure the resistance of the probe circuit with the multimeter set to ohm. Do you have $110\ \Omega$ at $25\text{ }^{\circ}\text{C}$ ($77\text{ }^{\circ}\text{F}$)? <ul style="list-style-type: none"> ■ If not, replace the damaged temperature probe ■ If yes, replace the power board
The cooking chamber has spots and smears on stainless steel and glasses	The inflow water hardness is too high accordingly with UNOX specification	If the inflow water quality is not in compliance with the technical data reported in the manual, install the proper water treatment system

Symptom	Problem	Solution
The cooking cabinet has spots of rust on the stainless steel	The chloride content in the inflow water is too high accordingly with UNOX specification	If the inflow water quality is not in compliance with the technical data reported in the manual, install a UNOX.Pure-RO. Polish the steel surface with a polish paste
The oven does not produce steam	The inflow water hardness is too high accordingly with UNOX specification	<p>Measure the inflow water pressure with a pressure gauge. Do you have a value within the range $1.5 < p < 6$ bar?</p> <ul style="list-style-type: none"> ■ If not, the water pressure is not in compliance with the UNOX specification ■ If yes, measure the pressure downstream the pressure reducer with a pressure gauge. Do you have a pressure equal to 2 bar? ■ If not, replace the pressure reducer ■ If yes, go on with the troubleshooting
	The oven does not pump in water	<p>Is the tap water open?</p> <ul style="list-style-type: none"> ■ If not, open the tap water ■ If yes, do you have power supply to the steam solenoid measuring with the multimeter set to V AC? <ul style="list-style-type: none"> ■ If not, replace the power board ■ If yes, is the steam pipe clogged? <ul style="list-style-type: none"> ■ If yes, clean the pipe and check the water quality ■ If not, replace the steam solenoid
The control panel is blank	The oven is in stand-by mode	When the oven is not running, every 15 minutes it goes in stand-by mode: the control panel is blank while the LED bar is turned on. To wake up the oven it is enough to touch the control panel on any point, except on the physical button in case of PLUS models. If for any reason the display does not turn on, press the power button to reboot the oven manually
	The control panel is not powered or damaged or the USB board is damaged	<p>Remove the control panel and measure between the black and yellow PIN of the main connector with the multimeter set to V DC, if you have 12 V DC. Do you have the right voltage?</p> <ul style="list-style-type: none"> ■ If yes, replace either the control board or the USB board ■ If not, open the back of the oven and measure the voltage between PIN 1 and 4 of the P11 socket with the multimeter set to V DC. Do you have 12 V DC? <ul style="list-style-type: none"> ■ If yes, replace the control-power board cable harness ■ If not, measure on the P21 socket of the power board between the yellow cable and between the red cable (only for PLUS version) if you have 12 V AC and 21 V AC respectively, with the multimeter set to V AC. Do you have the right voltage? <ul style="list-style-type: none"> ■ If yes, replace the power board ■ If not, measure on the transformer between the yellow cable and between the red cable (only for PLUS version) if you have 12 V AC and 21 V AC respectively, with the multimeter set to V AC. Do you have the right voltage? <ul style="list-style-type: none"> ■ If yes, replace the cable harness ■ If not, measure on the transformer between the grey cable if you have 230 V AC, with the multimeter set to V AC. Do you have the right voltage? <ul style="list-style-type: none"> ■ If yes, replace the transformer ■ If not, measure on the P1 socket between PIN labelled as NF and LF if you have 230 V AC, with the multimeter set to V AC. Do you have the right voltage? <ul style="list-style-type: none"> ■ If yes, replace the cable harness ■ If not, verify the F2 fuse. Is it fine? ■ If yes, replace the power board ■ If not, replace first the transformer that maybe is shorted and then the fuse

Symptom	Problem	Solution
The control panel is completely white	The LCD screen is damaged	Replace the control panel
The brightness of the control panel is very low	The LCD screen is damaged	Replace the control panel
The color of the panel is very faded	The LCD screen is damaged	Replace the control panel
There are some vertical or horizontal lines on the control panel	The LCD screen is damaged	Replace the control panel
The control panel does not respond	The LCD screen is damaged	Replace the control panel
There are some vertical or horizontal lines on the control panel	The LCD screen could be damaged	Wait for about 5 minutes. If the issue persists, replace the control panel
The buzzer does not sound	Either the control panel or the USB board are defected	Try to replace first the USB board and then the control panel
Contactors are chattering	Some metal dust is on the contact or the relay on the power board is defective	<p>Measure the contactor power supply between pins A1 and A2, with the multimeter set to V AC. Do you have a stable value of voltage, around 230 V AC?</p> <ul style="list-style-type: none"> ■ If not, replace the power board ■ If yes, try to set any cooking program and open and close the door while the oven is running. Does the issue persist? <ul style="list-style-type: none"> ■ If yes, try to clean the contact of the contactors with compressed air. Does the issue persist? ■ If yes, replace the contactors
Water leakage from the inlet water pipe, washing circuit, or steam circuit	Water leakage has been detected originating from the inlet water pipe, washing circuit, or steam circuit.	<p>In the event of water leakage from the inlet water pipe, washing circuit, or steam circuit, after the leak has been repaired, verify the correct operation of the pressure reducer.</p> <p>A malfunction caused by a water hammer may damage the pressure reducer, potentially leading to a pressure surge. This pressure peak can result in pipe disconnection or fitting dislodgement.</p> <p>When functioning correctly, the pressure downstream of the pressure reducer should be approximately 2.3 bar.</p>



INVENTIVE SIMPLIFICATION

EUROPE

IT - ITALIA UNOX S.p.a E-mail: info@unox.it Tel: +39 049 8657511	GB - UNITED KINGDOM UNOX UK Ltd. E-mail: info@unoxuk.com Tel: +44 1252 851 522	CZ - ČESKÁ REPUBLIKA UNOX DISTRIBUTION s.r.o. E-mail: info.cz@unox.com Tel: +420 241 940 000	BG - БЪЛГАРИЯ UNOX BULGARIA E-mail: info.bg@unox.com Tel: +359 2 419 05 00	NL - NETHERLANDS UNOX NETHERLANDS B.V. E-mail: info.nl@unox.com Tel: +31 6 27 21 14 10
DE - DEUTSCHLAND UNOX DEUTSCHLAND GMBH E-mail: info.de@unox.com Tel: +49 2951 98760	IE - IRELAND UNOX IRELAND E-mail: info.ie@unox.com Tel: +353 (0) 87 32 23 218	HR - HRVATSKA UNOX CROATIA E-mail: narudzbe@unox.com Tel: +39 049 86 57 538	AT - ÖSTERREICH UNOX ÖSTERREICH GMBH E-mail: info.de@unox.com Tel: +43 800 880 963	PL - POLSKA Unox Polska Sp.zo.o. E-mail: info.pl@unox.com Tel: +48 665 232 000
FR - FRANCE, BELGIUM & LUXEMBOURG UNOX FRANCE s.a.s. E-mail: info.fr@unox.com Tel: +33 4 78 17 35 39	ES - ESPAÑA UNOX PROFESIONAL ESPAÑA S.L. E-mail: info.es@unox.com Tel: +34 900 82 89 43	TR - TÜRKİYE - UNOX TURKEY Profesyonel mutfak ekipmanları endüstri ve ticaret limited şirketi E-mail: info.tr@unox.com Tel: +90 530 176 62 03	RU - РОССИЯ, ПРИБАЛТИКА И СТРАНЫ СНГ UNOX РОССИЯ E-mail: info.ru@unox.com Tel: +7 (499) 702 - 00 - 14	SC - SCANDINAVIAN COUNTRIES UNOX SCANDINAVIA AB E-mail: info.se@unox.com Tel: +46(0)790 75 63 64
PT - PORTUGAL UNOX PORTUGAL E-mail: info.pt@unox.com Tel: +351 918 228 787				

AMERICA

US - U.S.A. & CANADA UNOX Inc. E-mail: info.usa@unox.com Tel: +1 800 489 8669	AR - ARGENTINA UNOX ARGENTINA E-mail: info.ar@unox.com Tel: +54 911 37 58 43 46	CO - COLOMBIA UNOX COLOMBIA E-mail: info.co@unox.com Tel: +57 350 65 88 204	BR - UNOX BRASIL SERVICOS LTDA. E-mail: info.br@unox.com Tel: +55 11 98717-8201	MX - MEXICO UNOX MEXICO, S. DE R.L. DE C.V. E-mail: info.mx@unox.com Tel: +52 55 8116-7720
---	---	---	---	---

ASIA, OCEANIA & AFRICA

ZA - SOUTH AFRICA UNOX SOUTH AFRICA E-mail: info.sa@unox.com Tel: +27 845 05 52 35	PH - PHILIPPINES UNOX PHILIPPINES E-mail: info.asia@unox.com Tel: +63 9173108084	AU - AUSTRALIA UNOX AUSTRALIA PTY Ltd. E-mail: info@unoxaustralia.com.au Tel: +61 3 9876 0803	UZ - UZBEKISTAN UNOX PRO LLC E-mail: info.uz@unox.com Tel: +998 90 370 90 10	KR - 대한민국 UNOX KOREA CO. Ltd. 이메일: info.asia@unox.com 전화: +82 2 69410351
AC - OTHER ASIAN COUNTRIES UNOX (ASIA) SDN. BHD E-mail: info.asia@unox.com Tel: +603-58797700	TW - TAIWAN, HONG KONG & MACAU UNOX TAIWAN E-mail: info.tw@unox.com Tel: +886 928 250 536	MY - MALAYSIA & SINGAPORE UNOX (ASIA) SDN. BHD E-mail: info.asia@unox.com Tel: +603-58797700	CN - 中华人民共和国 UNOX TRADING (SHANGAI) Ltd. CO. 电子邮件: info.asia@unox.com 电话: +603-58797700	NZ - NEW ZEALAND UNOX NEW ZEALAND Ltd. E-mail: info@unox.co.nz Tel: +64 (0) 800 76 0803
AE - U.A.E. UNOX MIDDLE EAST DMCC E-mail: info.uae@unox.com Tel: +971 4 554 2146	ID - INDONESIA UNOX INDONESIA E-mail: info.asia@unox.com Tel: +62 81908852999			

unox.com



L11108A6

All images used are for illustrative purposes only.
All features indicated in this catalogue may be subject to change and could be updated without notice.