



# CHEFTOP™ - BAKERTOP™ MIND.Maps

## INSTALLATION MANUAL





# CHEFTOP™ - BAKERTOP™ MIND.Maps

## INSTALLATION PART

<b>INTRODUCTION</b> .....	<b>4</b>
<b>FORWARD</b> .....	<b>4</b>
<b>EXPLANATION OF PICTOGRAMS</b> .....	<b>4</b>
<b>SAFETY REGULATIONS FOR INSTALLATION AND MAINTENANCE</b> .....	<b>5</b>
<b>UNPACKING THE EQUIPMENT</b> .....	<b>7</b>
<b>CHECKING PACKAGE CONTENT</b> .....	<b>8</b>
<b>GETTING STARTED</b> .....	<b>9</b>
<b>POSITIONING</b> .....	<b>10</b>
<b>ELECTRICAL CONNECTIONS</b> .....	<b>20</b>
<b>GAS CONNECTIONS (ONLY FOR GAS OVENS)</b> .....	<b>23</b>
<b>PLUMBING CONNECTIONS</b> .....	<b>26</b>
<b>FILLING THE DETERGENT TANK</b> .....	<b>39</b>
<b>EXHAUST (ONLY FOR ELECTRICAL OVENS)</b> .....	<b>39</b>
<b>FUMES AND COMBUSTION GASSES EXHAUST (ONLY FOR GAS OVENS)</b> .....	<b>40</b>
<b>OVEN RESETTING PROCEDURE (RESERVED FOR SERVICE CALLS)</b> .....	<b>41</b>
<b>CONNECTING STACKED APPLIANCES (MAXI.LINK)</b> .....	<b>41</b>
<b>PLANNED MAINTENANCE SERVICE (ANNUALLY)</b> .....	<b>41</b>
<b>DISPOSAL</b> .....	<b>42</b>
<b>CERTIFICATION</b> .....	<b>42</b>

## INTRODUCTION

Dear Customer,

We thank you for having purchased an oven / complementary accessory from the **CHEFTOP-BAKERTOP MIND.Maps™** line.

These ovens are the climax of Unox research and guarantee minimum occupation of space with superlative performance while offering outstanding cooking management at any condition of use and load.

The **CHEFTOP-BAKERTOP MIND.Maps™** ovens use UNOX's finest patented technology, which is the result of collaborations with master chefs and the world's leading research institutions.

A wide array of available accessories make these ovens extremely versatile and streamline everyday kitchen duties.

## FORWARD

This booklet shows the installation of **CHEFTOP-BAKERTOP MIND.Maps™** line of appliances.

The **CHEFTOP MIND.Maps™** line of ovens, together with their accessories, allow to complete cooking solutions using the **MAXI.Link** technology dedicated to superb cuisine, such as: **SlowTop** oven with temperature maintainer and combination of two or more ovens.

**CHEFTOP MIND.Maps™** are available in gas and electric models; they have digital controls and their capacities are as follows: 5, 10 **GN 1/3** - 5 **GN 2/3** - 3, 5, 7, 10, 20 **GN 1/1** - 6, 10, 20 **GN 2/1**.

The ovens of the **BAKERTOP MIND.Maps™** line, along with their accessories, make it possible to create complete BAKING STATIONS for the production of pastry and baked goods. With these ovens, it is possible to cook: puff pastry, sponge cakes, biscuits, choux pastry, croissants, pizza, focaccia bread, panettone cakes and leavened goods.

The **BAKERTOP MIND.Maps™** models are available in gas and electric models, have digital control and the following capacities: 4, 6, 10, 16 trays 600x400.

All electric ovens are available, depending on the equipment, in the **ZERO**, **ONE** or **PLUS** versions; this allows you to choose either one of the simpler versions or the very best of UNOX practicality and innovation.

Gas ovens are available in the **PLUS** version only.

The **ZERO** versions are only available for the electric models 5/7/10 GN 1/1.

 We recommend you thoroughly read this manual for all instructions on how to maintain the aesthetic and functional qualities of your purchased product intact.

## EXPLANATION OF PICTOGRAMS

The installation and user instructions are valid for all models unless otherwise specified by the following pictograms:



Danger! Situation presenting immediate danger, or a hazardous situation which could cause injury or death.



Danger: fire hazard!



Tips and useful information



Danger: electric shock!



Earthing symbol



Read the instruction manual



Equipotential symbol





Danger: risk of burns



Consult other chapter

## SAFETY REGULATIONS FOR INSTALLATION

- Read this guide carefully before installing or maintaining the appliance, and conserve this guide with care for any future consultation of users.
- All installation, assembly and non-routine maintenance operation must be performed exclusively by qualified technicians that are authorized by UNOX, in compliance with the regulations in force in the user country, with respect to the regulations on systems and work safety.
- Disconnect the oven from its electrical and gas supplies before installation or maintenance (only for gas ovens).
- Check that systems are compliant to the installation country standards and to the specifications indicated on the appliance rating plate before installing the appliance.
- Interventions, tampering or modifications not expressly approved that do not comply with the instructions in this manual could cause damage, injury or death.
- Furthermore, interventions, tampering or modifications not expressly authorised that do not comply with the indications in this manual shall invalidate the guarantee.
- Installation or maintenance that fails to respect the indications in this manual may cause damage, injury or fatal accidents.
- Persons not involved with appliance installation may not pass through or occupy the work area during appliance assembly.
- If the equipment is installed on mobile bases or stacked in columns, be sure to use only UNOX components and respect the instructions on their packaging.
- Given their potential danger, the packaging materials must be kept out of reach of children and animals, and correctly disposed of in compliance with local regulations.
- The ratings plate provides essential technical information that is of utmost importance for any appliance maintenance or repairs. Do not remove, damage or modify the plate.
- Failure to follow these instructions can cause damage and injury or death, voids the warranty and exempts UNOX from any liability.
- The parts protected by the manufacturer or his agent shall not be adjusted by the installer.
- The appliance can be used by children of 8 years and over and by people with reduced physical, sensory or mental capabilities or people lacking the experience or knowledge needed, provided they are supervised or have received instructions on how to use the appliance safely and that they understand the inherent dangers. Children must not play with the appliance. User cleaning and maintenance must not be carried out by unsupervised children.
- When cleaning any component or accessory NEVER use water jets.
- The new hose-sets supplied with the appliance are to be used for the connection to the water supply network. Old hose-sets should not be reused.
- For proper electrical connections, the appliance must:
  - Be wired into an equipotential system in accordance with current regulations. This connection must be performed between different appliances with the terminal marked with the equipotential symbol . The cable must have a maximum cross-section of 10 mm<sup>2</sup> (pursuant to standard CEI EN 60335-2-36) and be yellow-green.

- Be connected to the mains earth  (green-yellow wire).
- Be connected to a thermal differential switch in compliance with the regulations in force (0.03A, type A).
- Be connected to a main circuit-breaker that enables complete disconnection in category III over-voltage conditions.
- Do not use the door to push the trolley in the oven cavity, to not damage the trolley gasket.

## ONLY FOR GAS OVENS

- Appliances must be installed in areas:
  - that comply to the safety requirements called for by the standards in force;
  - that have adequate ventilation. Make sure that air is continually refreshed from the outside to ensure correct combustion and to avoid the formation of volatile substances hazardous to health and risk of suffocation!
- Make sure:
  - that installation is performed by respecting the safety regulations of the country of use and of the gas company;
  - that the ventilation inlets and the appliance exhausts are not obstructed (e.g. objects and walls);
  - that the type of gas available corresponds to the type indicated on the rating label;
  - that the gas pipe diameters meet the required measurements;
  - that components - not supplied by UNOX - used for installation comply with the regulations in force of the country of use;
  - that the connection pipe pressure equals that of the gas supply inlet;
  - that maximum gas piping inlet pressure is 55 mbar; pressures may not exceed this threshold.
- After connection to the gas supply, check for gas leaks of the components by preferably using non-corrosive foams. Never use flames!
- Upon commissioning a qualified technician authorised by UNOX must analyse the burner exhaust gases (CO and CO<sub>2</sub>) and record the registered values on the appliance.

## RISK OR ELECTRICAL SHOCK

- Do not open the compartments marked with these symbols: opening is reserved to qualified personnel authorised by UNOX. Failure to observe this regulation invalidates the guarantee and may cause damage or (fatal) injuries.

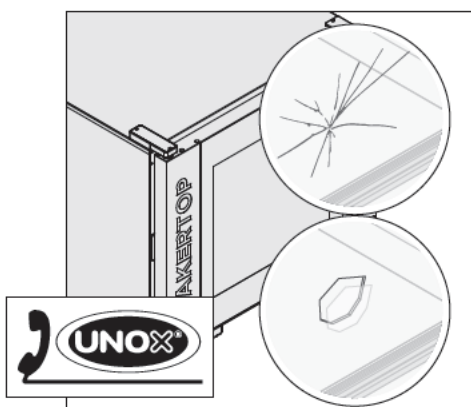

If the appliance glass is chipped or damaged, it must be replaced immediately by contacting an authorised support service centre. **Do not use the oven. Risk of exploding glass.**

# 1 UNPACKING THE EQUIPMENT

Check the package for any visible damage. If damage is found, immediately contact UNOX and DO NOT install the appliance.

Before transporting the appliance to its installation point, make sure that:

- it easily passes through doorways;
- the floor supports its weight.

Transport must be exclusively performed by mechanical means (i.e. transpallet forklift).

Given their potential danger, the packaging materials must be kept out of reach of children and animals, and correctly disposed of in compliance with local regulations.

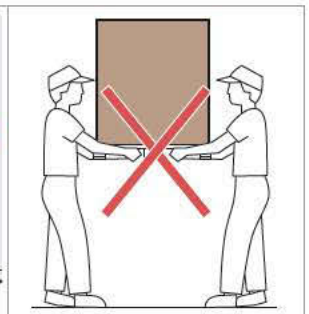
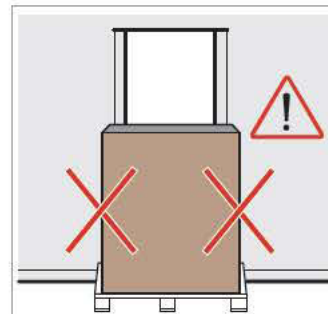
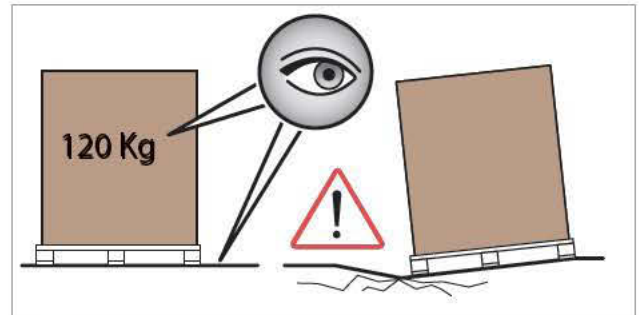
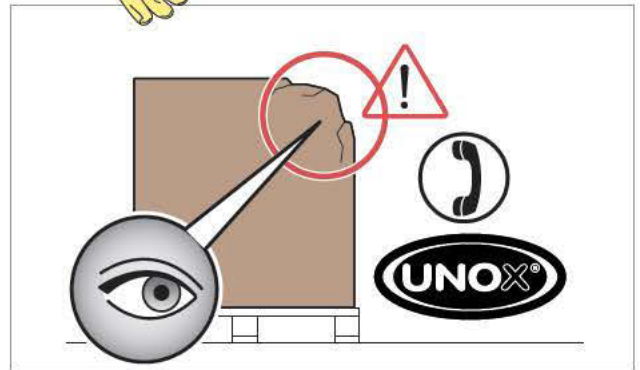
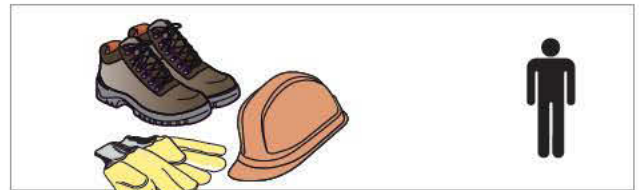
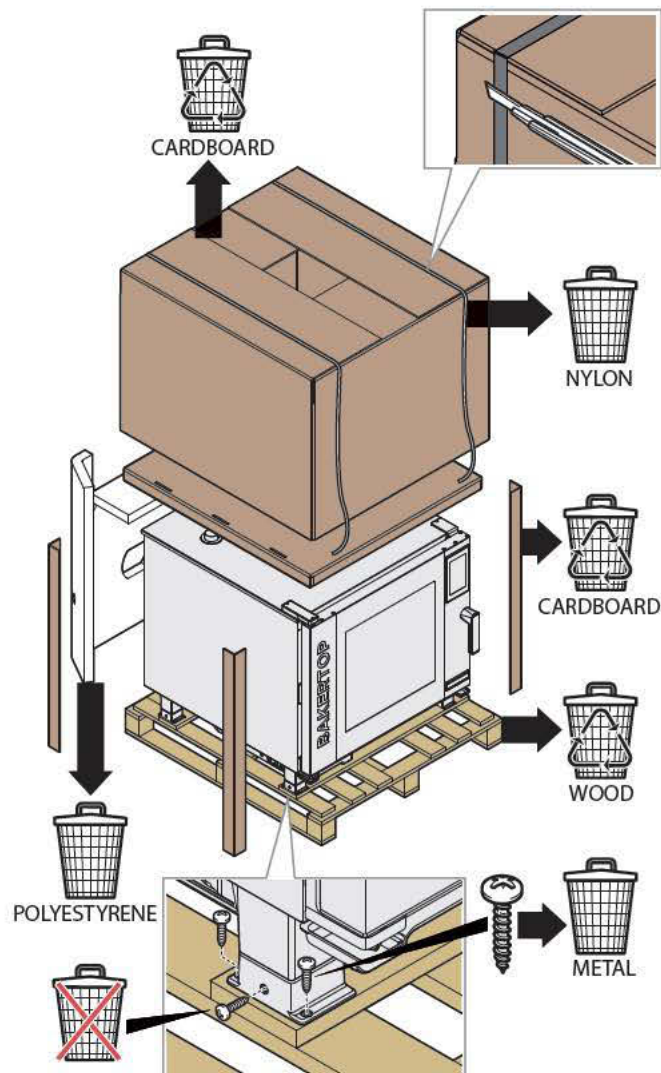

## NON-STOP Efforts

UNOX has followed the **NON-STOP Efforts** philosophy for years to increase the environmental compatibility of its products to reduce energy consumption and waste. UNOX wishes to protect the environment and invites the consumer to dispose of waste in recycling bins.

## 2 CHECKING PACKAGE CONTENTS

Before installing the appliance, check that the following packaged components are present and free of damage.

❗ Contact UNOX if a component is missing or damaged.

### | COUNTER TOP OVENS

① oven designed for:

- electrical connections (power supply cable fitted, plug to be fitted by the installer);
- plumbing (water supply tube, mechanical filter, 3/4 connection with non-return valve already assembled);

② technical documents (installation and use booklet, "Technical data" sheet);

③ 4 plastic supports;

④ "Starter Kit" bag (8 self-tapping screws, 1 connection spanner, 1 falling liquids adhesive label).

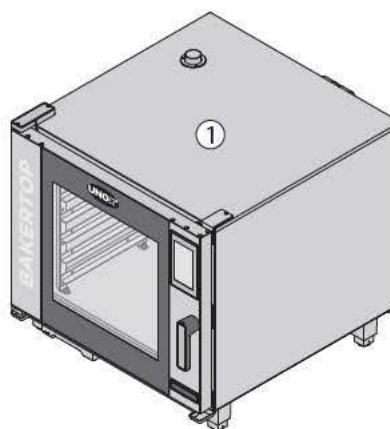

### | FREE STANDING OVENS WITH/WITHOUT TROLLEY

① oven designed for:

- electrical connections (power supply cable and plug not fitted);
- plumbing (water supply tube, mechanical filter, 3/4 connection with non-return valve already assembled);

② technical documents (use and installation manual, "Technical specifications" sheet);

③ 2 plastic supports;

④ 1 "Starter Kit" bag (8 self-tapping screws, 1 attachment spanner, 1 falling liquids adhesive label, plugs);

⑤ trolley (only for models with trolley).

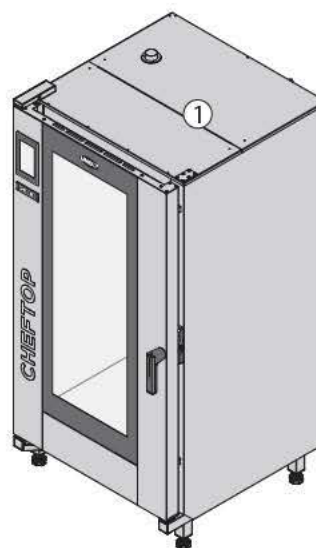

⊕ Different auxiliary instruments are available as professional completion of the **ChefTop™ - BakerTop™** **MIND.Maps** ranges: contact UNOX for additional information.

### 3 GETTING STARTED

#### REMOVING THE PROTECTIVE FILM AND SILICONE CAP FROM THE CORE PROBE

Slowly remove the protective films from the appliance: clean any glue residue with appropriate solvents without using tools, abrasive detergents or acids that could ruin the surfaces.

**!** The removed film, given its potential danger, must be kept out of reach of children and animals; and correctly disposed of in compliance with local regulations.

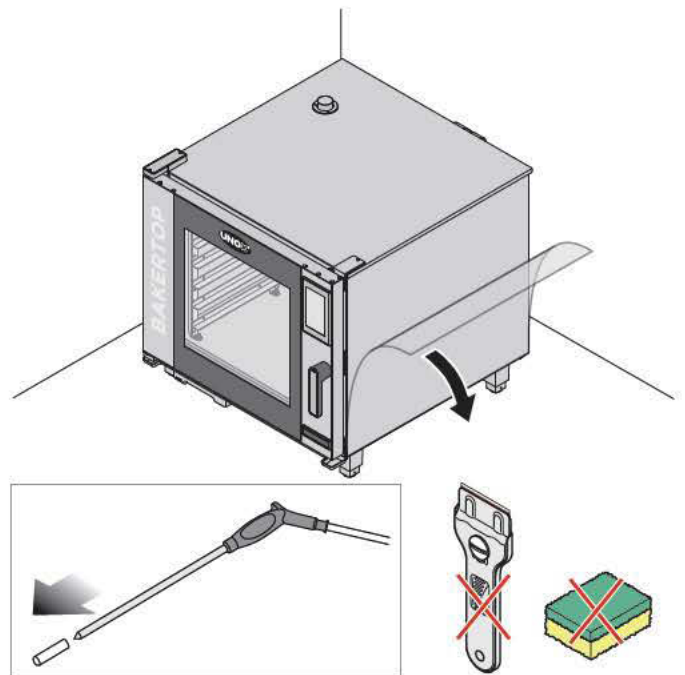

EN

### 4 POSITIONING

#### CHARACTERISTICS OF THE INSTALLATION AREA

- Install the appliance in areas:
- dedicated and conforming to the cooking of industrial foods;
  - having adequate air ventilation;
  - that comply with the laws in your country;
  - protected against the weather;
  - with temperatures between +5° to +35°C maximum;
  - having a maximum humidity of 70%.

The law requires gas appliances to be installed in areas:

- with surface area and ventilation suitable for gas combustion;
- with outdoor evacuation of exhaust gas.

**!** For additional information consult chapter "Exhaust (only for electrical ovens)" on page 37.

**!** Do not install the appliance near other appliances that reach high temperatures in order to avoid damaging electrical parts.

The appliance cannot be installed into a recess. Make sure that the floor supports the weight of the appliance at full capacity (see the table below).

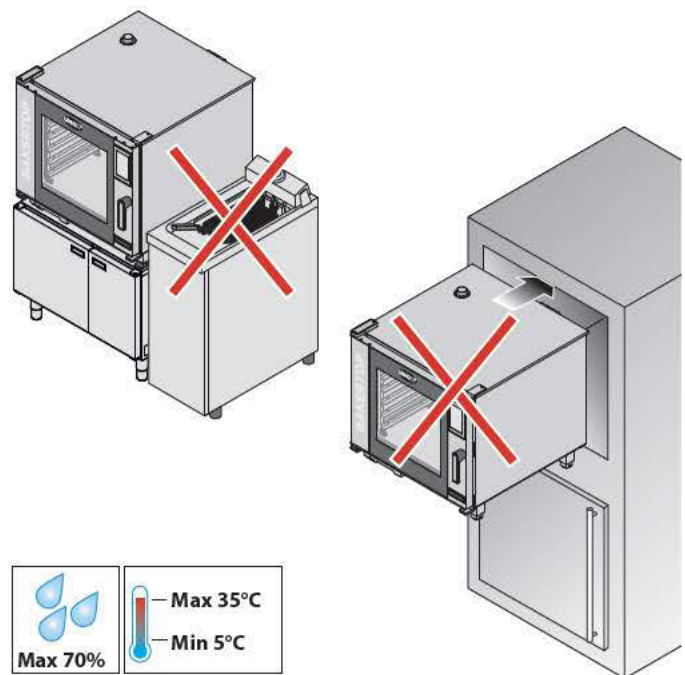

**!** For additional technical information on the appliance, consult the "technical specifications" sheet attached to the appliance.



**TAB. 1. ► OVENS TECHNICAL DATA**

CHEFTOP MIND. Maps™		Tray Type	Size [mm] WxDxH	N. tray	Oven weight [kg]	Max. load [kg]	Oven model		Installation
<b>COMPACT XECC</b>	<b>Electric</b>	<b>GN2/3</b>	535x672x649	5	56	17	<b>ONE</b>	XECC-0523-E1xM	Countertop
			535x672x649	5	58	17	<b>PLUS</b>	XECC-0523-EPxM	Countertop
		<b>GN1/3</b>	535 x 872 x 649	5	68	25	<b>PLUS</b>	XECC-0513-EPxM	Countertop
			535 x 872 x 984	10	90	45	<b>PLUS</b>	XECC-1013-EPxM	Countertop
<b>XEVC</b>	<b>Electric</b>	<b>GN1/1</b>	750x783x538	3	54	15	<b>ONE</b>	XEVC-0311-E1xM	Countertop
			750x783x675	5	66	25	<b>ONE</b>	XEVC-0511-E1xM	Countertop
			750x783x675	5	66	25	<b>ONE</b>	XEVC-0511-E1xM-LP	Countertop
			750x783x843	7	82	35	<b>ONE</b>	XEVC-0711-E1xM	Countertop
			750x783x1010	10	92	45	<b>ONE</b>	XEVC-1011-E1xM	Countertop
			750x783x538	3	56	15	<b>PLUS</b>	XEVC-0311-EPxM	Countertop
			750x783x675	5	70	25	<b>PLUS</b>	XEVC-0511-EPxM	Countertop
			750x783x675	5	70	25	<b>PLUS</b>	XEVC-0511-EPxM-MS	Countertop
			750x783x843	7	86	35	<b>PLUS</b>	XEVC-0711-EPxM	Countertop
			750x783x843	7	86	35	<b>PLUS</b>	XEVC-0711-EPxM-MS	Countertop
			750x783x1010	10	98	45	<b>PLUS</b>	XEVC-1011-EPxM	Countertop
			750x783x1010	10	98	45	<b>PLUS</b>	XEVC-1011-EPxM-MS	Countertop
			750x783x675	5	64	25	<b>ZERO</b>	XEVC-0511-EZxM	Countertop
			750x783x675	5	64	25	<b>ZERO</b>	XEVC-0511-EZxM-LP	Countertop
	750x783x843	7	80	35	<b>ZERO</b>	XEVC-0711-EZxM	Countertop		
	750x783x1010	10	90	45	<b>ZERO</b>	XEVC-1011-EZxM	Countertop		
	<b>GN2/1</b>	860x1145x842	6	120	60	<b>PLUS</b>	XEVC-0621-EPxM	Countertop	
		860x1145x1162	10	180	60	<b>PLUS</b>	XEVC-1021-EPxM	Countertop	
	<b>Gas</b>	<b>GN1/1</b>	750x783x675	5	83	25	<b>PLUS</b>	XEVC-0511-GPxM	Countertop
			750x783x675	5	83	25	<b>PLUS</b>	XEVC-0511-GPxM-MS	Countertop
750x783x843			7	104	35	<b>PLUS</b>	XEVC-0711-GPxM	Countertop	
750x783x843			7	104	35	<b>PLUS</b>	XEVC-0711-GPxM-MS	Countertop	
750x783x1010			10	117	45	<b>PLUS</b>	XEVC-1011-GPxM	Countertop	
750x783x1010			10	117	45	<b>PLUS</b>	XEVC-1011-GPxM-MS	Countertop	
750x783x842			6	120	60	<b>PLUS</b>	XEVC-0621-GPxM	Countertop	
750x783x1162			10	190	60	<b>PLUS</b>	XEVC-1021-GPxM	Countertop	
<b>BIG XEVL</b>	<b>Electric</b>	<b>GN1/1</b>	892x925x1875	20	292	90	<b>ONE</b>	XEVL-2011-E1xS	Free-standing
			892x925x1875	20	292	90	<b>PLUS</b>	XEVL-2011-YPxS	Free-standing
			892x925x1875	20	339	90	<b>PLUS</b>	XEVL-2011-DPxS	Free-standing
			892x1164x1875	20	339	180	<b>PLUS</b>	XEVL-2021-YPxS	Free-standing
			892x1164x1875	20	339	180	<b>PLUS</b>	XEVL-2021-DPxS	Free-standing
	<b>Gas</b>	<b>GN1/1</b>	892x925x1875	20	285	90	<b>PLUS</b>	XEVL-2011-GPxS	Free-standing
892x1164x1875			20	363	180	<b>PLUS</b>	XEVL-2021-GPxS	Free-standing	
<b>BIG XECL COMPACT</b>	<b>Electric</b>	<b>GN 1/3</b>	650x1002x1875	20	285	90	<b>ONE</b>	XECL-2013-E1xS	Free-standing
			650x1002x1875	20	296	90	<b>PLUS</b>	XECL-2013-YPxS	Free-standing
BAKERTOP MIND. Maps™		Tray Type	Size [mm] WxDxH	N. tray	Oven weight [kg]	Max. load [kg]	Oven model		Installation
<b>XEBC</b>	<b>Electric</b>	<b>600 x 400</b>	860x967x675	4	90	20	<b>ONE</b>	XEBC-04EU-E1xM	Countertop
			860x967x843	6	103	30	<b>ONE</b>	XEBC-06EU-E1xM	Countertop
			535x872x1163	10	136	50	<b>ONE</b>	XEBC-10EU-E1xM	Countertop
			860x967x675	4	95	20	<b>PLUS</b>	XEBC-04EU-EPxM	Countertop
			860x967x843	6	112	30	<b>PLUS</b>	XEBC-06EU-EPxM	Countertop
			860x967x1163	10	148	50	<b>PLUS</b>	XEBC-10EU-EPxM	Countertop
	<b>Gas</b>		860x967x843	6	126	30	<b>PLUS</b>	XEBC-06EU-GPxM	Countertop
			860x967x1163	10	148	50	<b>PLUS</b>	XEBC-10EU-GPxM	Countertop
<b>BIG XEBL</b>	<b>Electric</b>	<b>600 x 400</b>	892x925x1875	16	292	85	<b>ONE</b>	XEBL-16EU-E1xS	Free-standing
			892x925x1875	16	292	85	<b>PLUS</b>	XEBL-16EU-YPxS	Free-standing
			892x925x1875	16	292	85	<b>PLUS</b>	XEBL-16EU-DPxS	Free-standing
	<b>Gas</b>		892x925x1875	16	309	85	<b>PLUS</b>	XEBL-16EU-GPxS	Free-standing

## CONNECTIONS

The installation areas must be equipped with electrical, plumbing and gas utilities (only for gas ovens) that comply with the regulations of the country of use.

The figure gives indicative connection measurements:

-  electrical connection
-  plumbing connection
-  gas connection (where applicable)

 If cooking large amounts of greasy foods, follow the precautions indicated in section “**Drainage specifications**” on page 33.

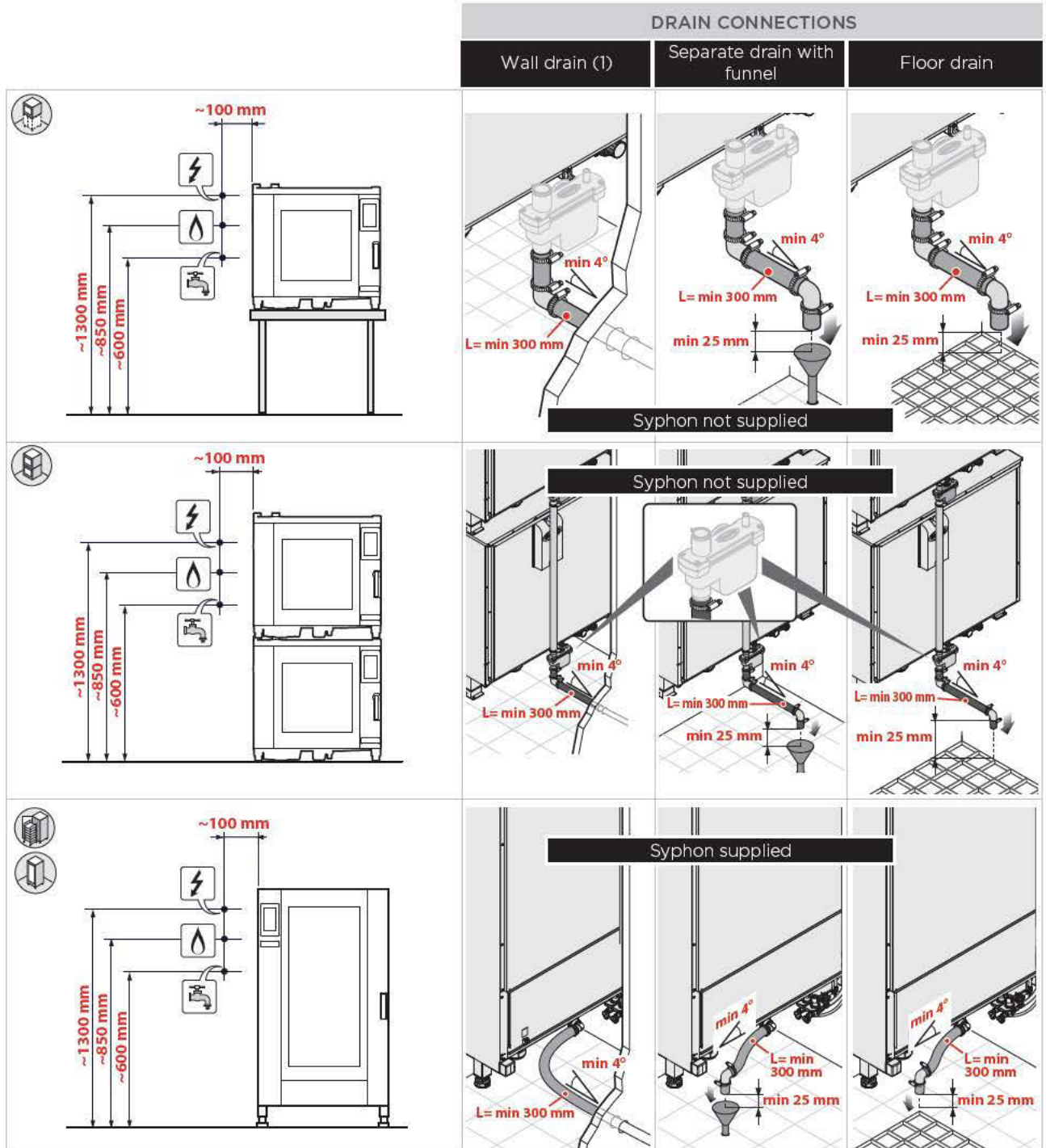

(1): The wall-mounted exhaust output must have an air gap of at least 25 mm.

## | APPLIANCE DISTANCES

Position the appliance respecting the indicated distances in the diagram and so that the back of the oven is easily accessible for appliance connections and maintenance.

⚠ Do not install the appliance near flammable or heat sensitive materials, walls or furniture. Otherwise, protect them with appropriate non-flammable materials in compliance with fire prevention regulations - see diagram below.

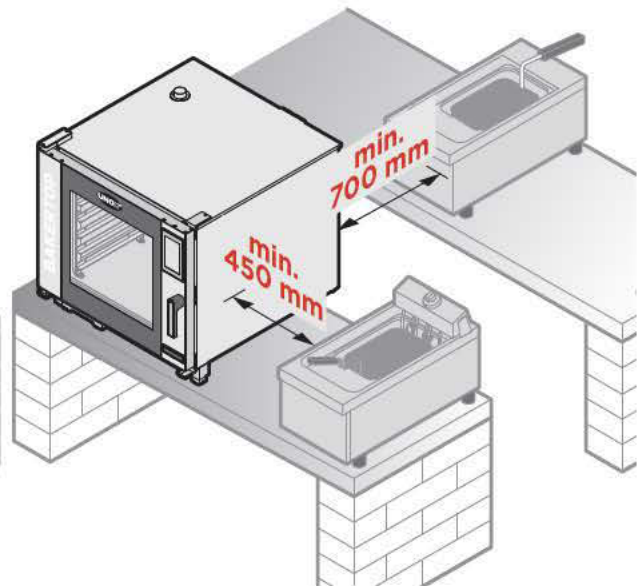
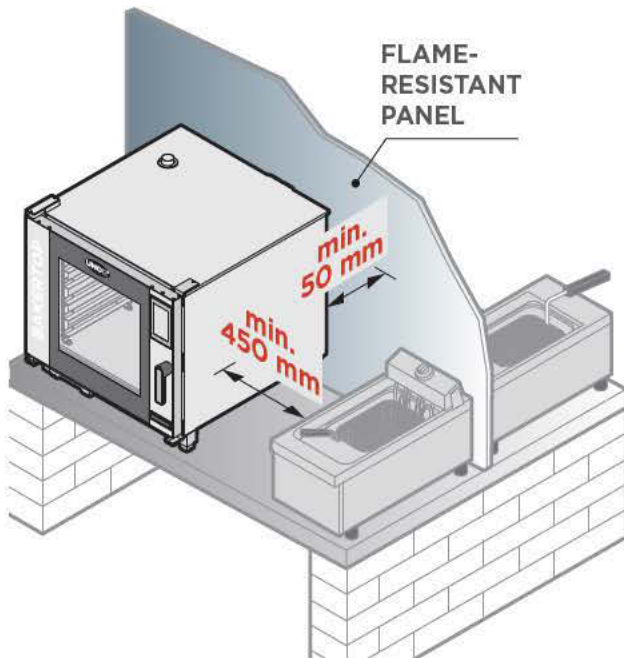
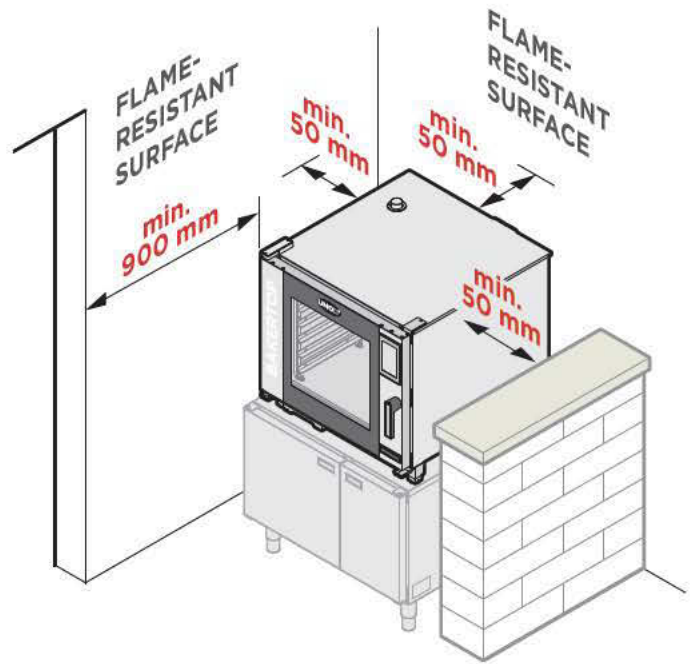

⚠ For safety reasons, the last tray should NEVER be placed at a height greater than 160 cm.

If necessary to do so, it is mandatory to post the sticker contained in the "Starter Kit" at the height shown in the figure.

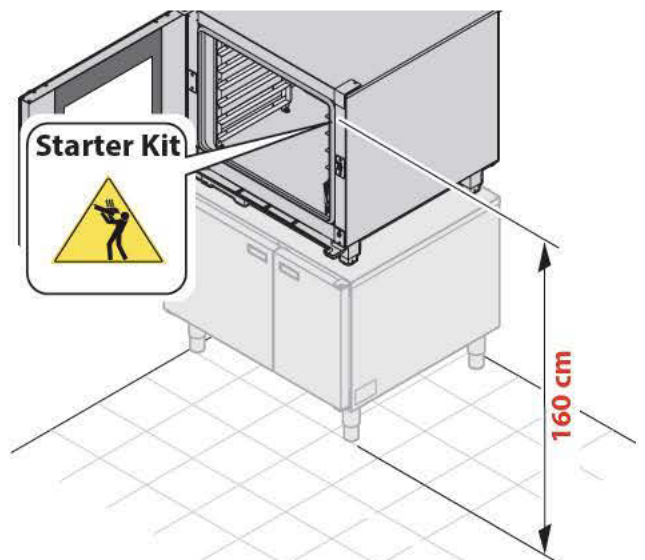

## 5 POSITIONING | COUNTERTOP OVENS

- The counter top ovens can be positioned:
- on wheels (with the UNOX wheel kit);
  - on the floor (with the UNOX feet kit);
  - on own or UNOX substructures;
  - stacked on other UNOX appliances (**MAXI. Link**).

### | FLOOR OR MOBILE-BASE POSITIONING

- The floor beneath the appliances must:
- be flame and heat resistant;
  - be perfectly level;
  - have a flat and even surface;
  - are able to support the appliance weight at full load without undergoing deformation or structural failure.

### | POSITIONING: FREE-STANDING

DO NOT position the appliances directly on the floor but remove the plastic feet from the appliance and assemble the UNOX H.150-mm steel feet support feet kit. Contact UNOX for detailed information on assembling the support feet Kit read the instructions on the kit packaging.

### | POSITIONING: MOBILE BASES

- ! Move the appliance using only the UNOX wheel kit and by following the instructions contained on the kit packaging.

### | POSITIONING: SUBSTRUCTURES

- ! Before securing on an UNOX substructure or on one of your own, always check that the substructure is perfectly level using a spirit or digital level. If not, the UNOX substructure can be levelled by adjusting the feet. Beware - do not completely unscrew the feet.

Anchoring on user's substructure (i.e. steel tables, etc...)

The substructures must be:

- stable and perfectly level;
- unmoveable;
- flame and heat resistant;
- are able to support the appliance weight at full load without undergoing deformation or structural failure.

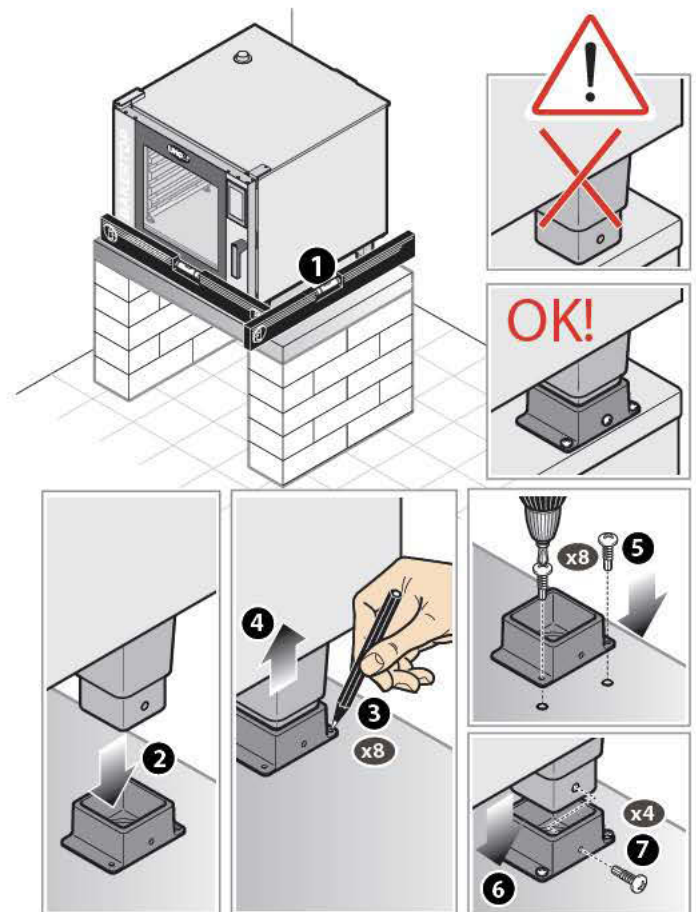
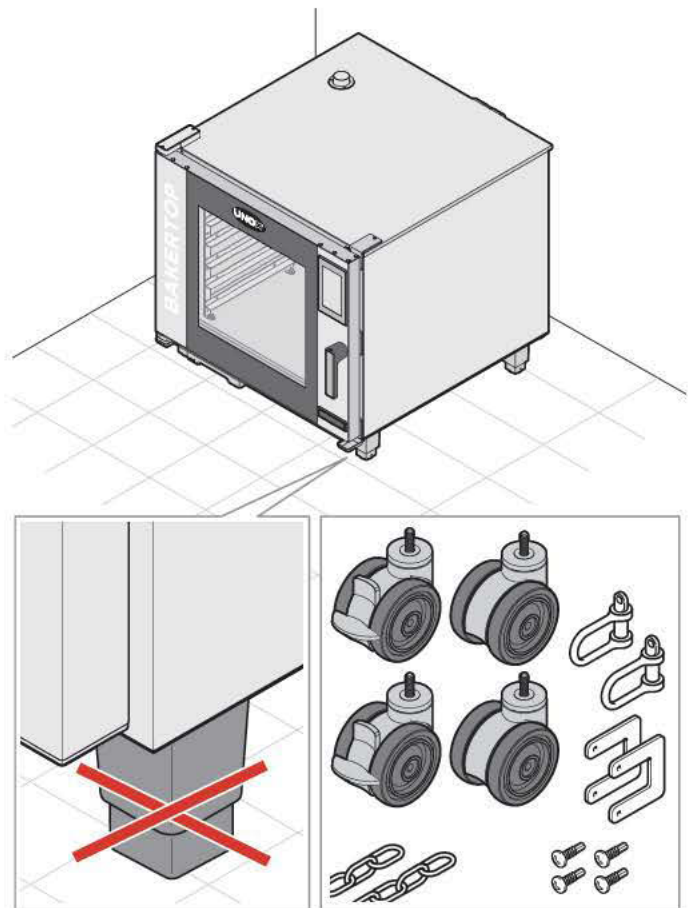

| ANCHORING ON UNOX SUBSTRUCTURES (PROVERS AND CABINETS)

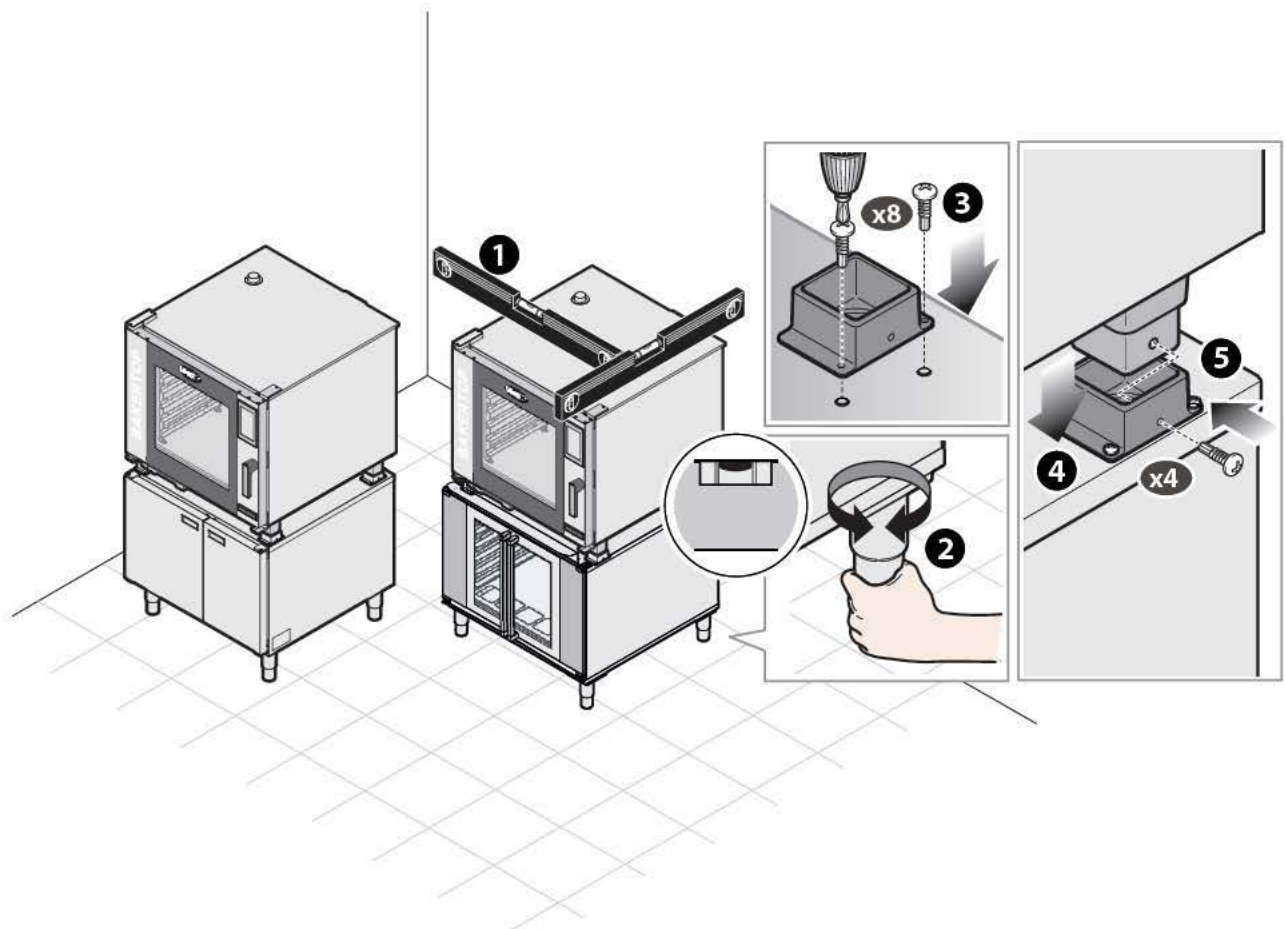

| ANCHORING ON UNOX SUBSTRUCTURES (HIGH OPEN STAND)

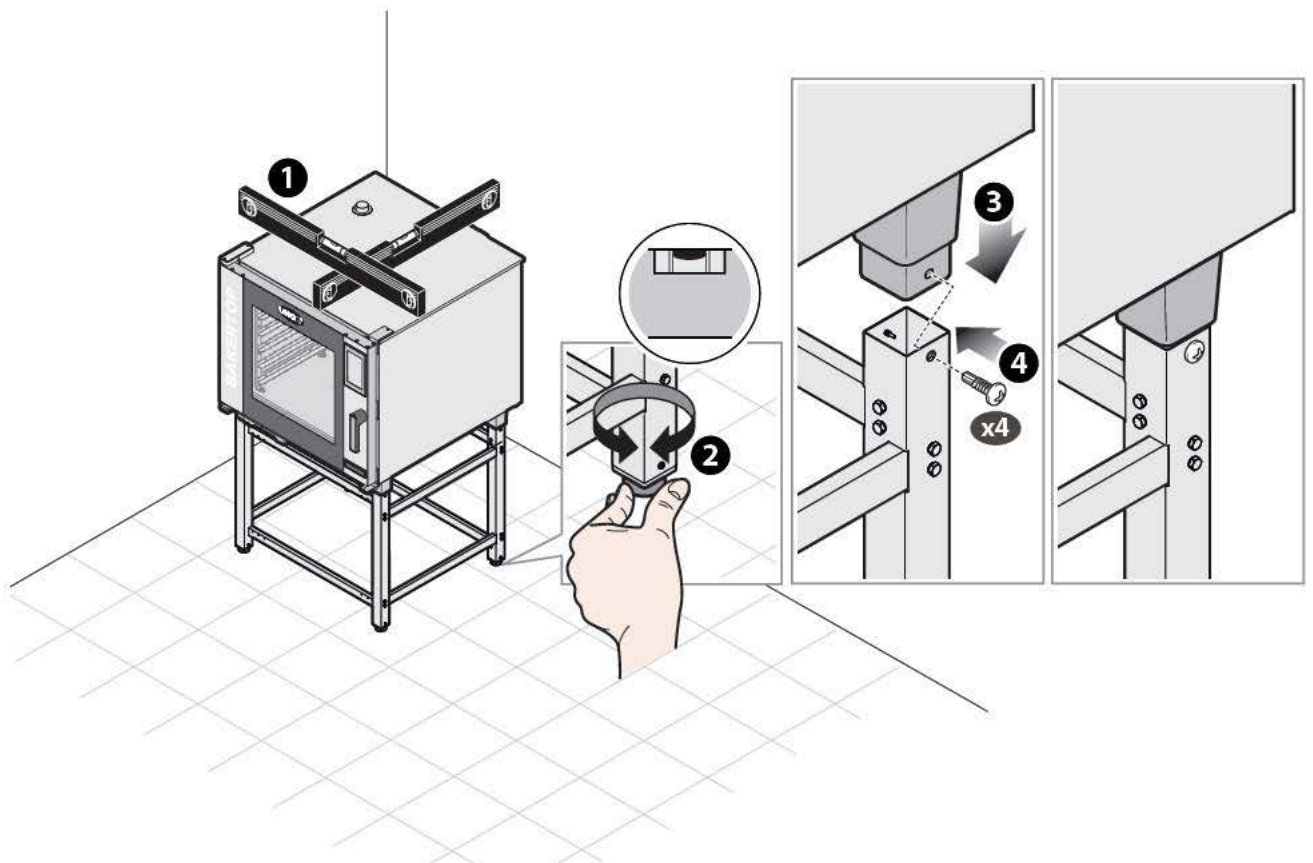

## | POSITIONING: APPLIANCE STACKING (MAXI.LINK)

Use UNOX's oven stacking kit when stacking multiple units.

It maintains the proper distance between appliances and simplifies electrical, plumbing and exhaust connections.

Follow the instructions on the packaging for stacking kit assembly.

- ⚠ The oven should never be placed immediately above other ovens or other sources of heat.
- ⚠ The tanks of detergent (where applicable) must always be installed under the prover or oven in the lowest position possible.
- ⊕ The oven stacking kit also contains a siphon and a Tee fitting for plumbing several appliances with a single water outlet.

Examples of possible compositions:

XEBC-10EU-EPxM

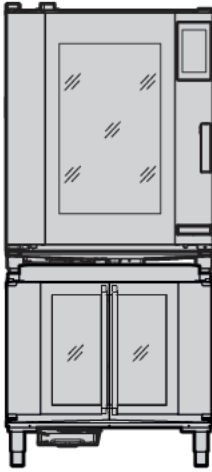

XEBC-10EU-EPxM

XEBC-06EU-EPxM



XEBPC-12EU-B

XEBC-06EU-EPxM



XEBPC-12EU-B

XEBC-10EU-EPxM



XEBPC-12EU-B

## 6 POSITIONING | FREE-STANDING “BIG” OVENS WITH/WITHOUT TROLLEY

Ovens of this type must be set on floors that meet the following requirements:

- be flame and heat resistant;
- be perfectly level;
- have a flat and even surface;
- are able to support the appliance weight at full load without undergoing deformation or structural failure.

### LEVELLING THE APPLIANCE

1 Make sure that the length of the oven cavity diagonals are the same, if this is not the case, it implies that the appliance is not flush -> 2 level it by adjusting the height of the 4 feet as follows:

- the front feet must be adjusted to align frontally between right and left
- the rear feet must be adjusted to reduce excessive inclinations of the oven

Minimum height from the ground must be 17.3 cm | 6.80" to give the trolley easy access.

Once level, check to see that the trolley easily enters into the oven cavity without encountering obstacles (e.g. floor irregularity) and without brushing against the bottom surface of the oven cavity.

Further adjust the feet if necessary.

! It is compulsory to anchor the 2 rear supports to the floor to avoid the oven falling over (see diagram on the following page).

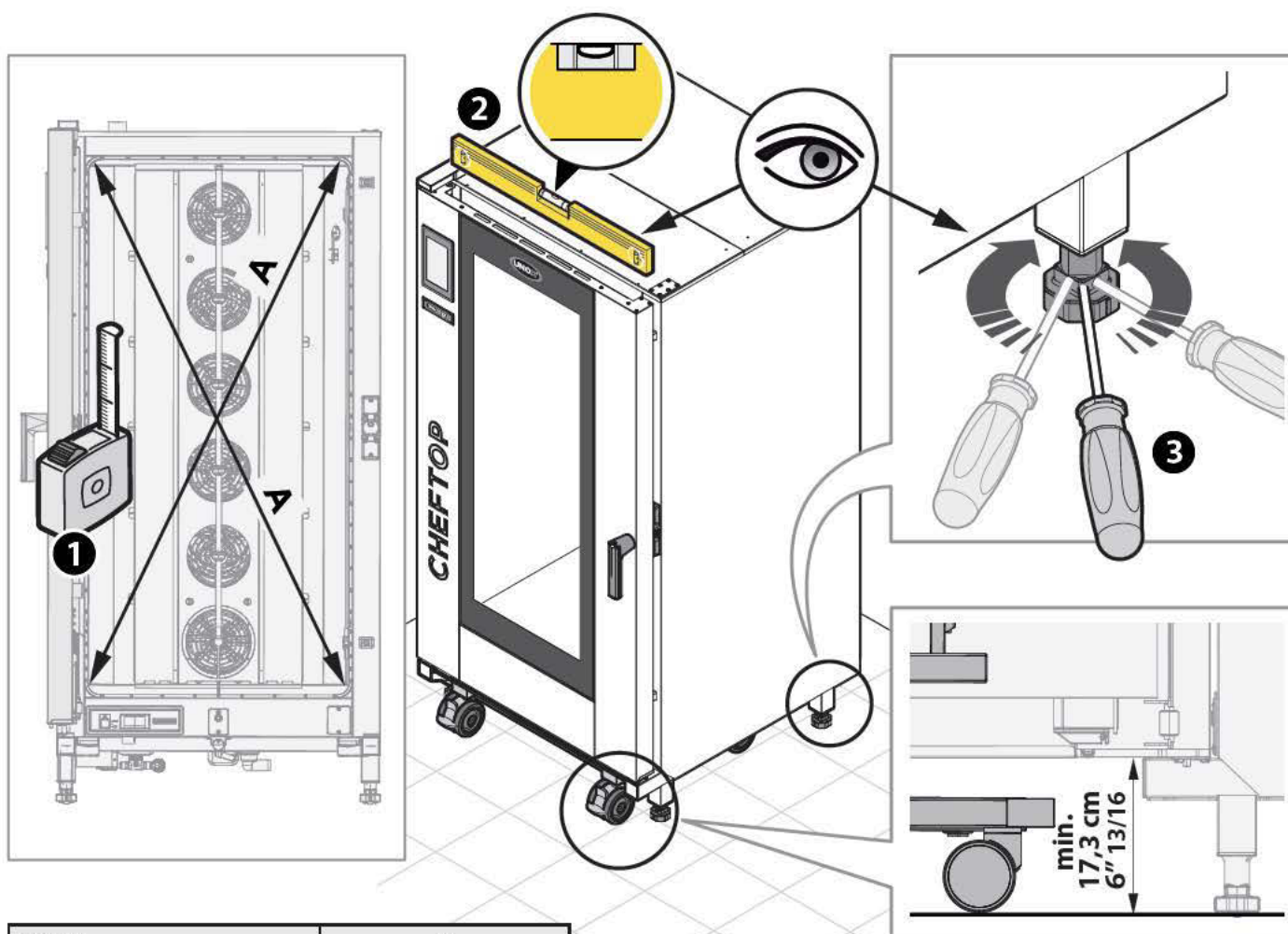

MODEL	A
BIG COMPACT XECL	1524mm   60"
BIG XEVL   XEBL	1600mm   63"

**SOLUTION - A**

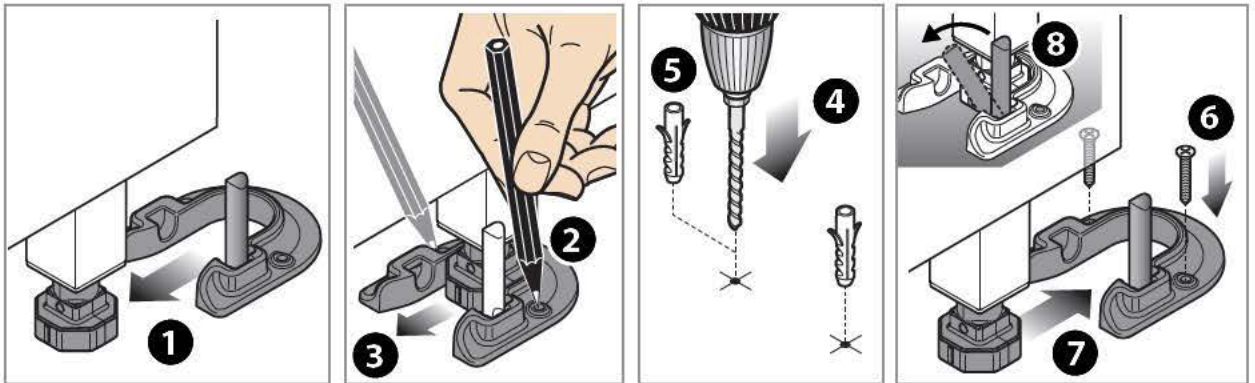

**SOLUTION - B**

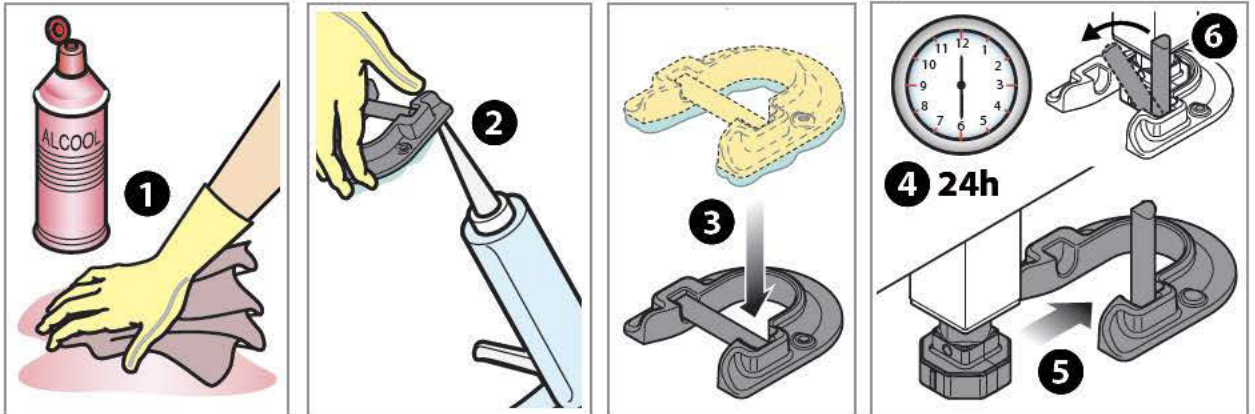

**EN**

**| ONLY FOR FREE-STANDING TROLLEY OVENS**

If the floor is not perfectly level, a loading ramp with a maximum incline of 4° may be used to simplify the loading of the trolley. The maximum floor incline allowed is 2°.

⚠ If floor incline exceeds this value, hot liquids may spill from the trays during loading/extraction and cause burns.

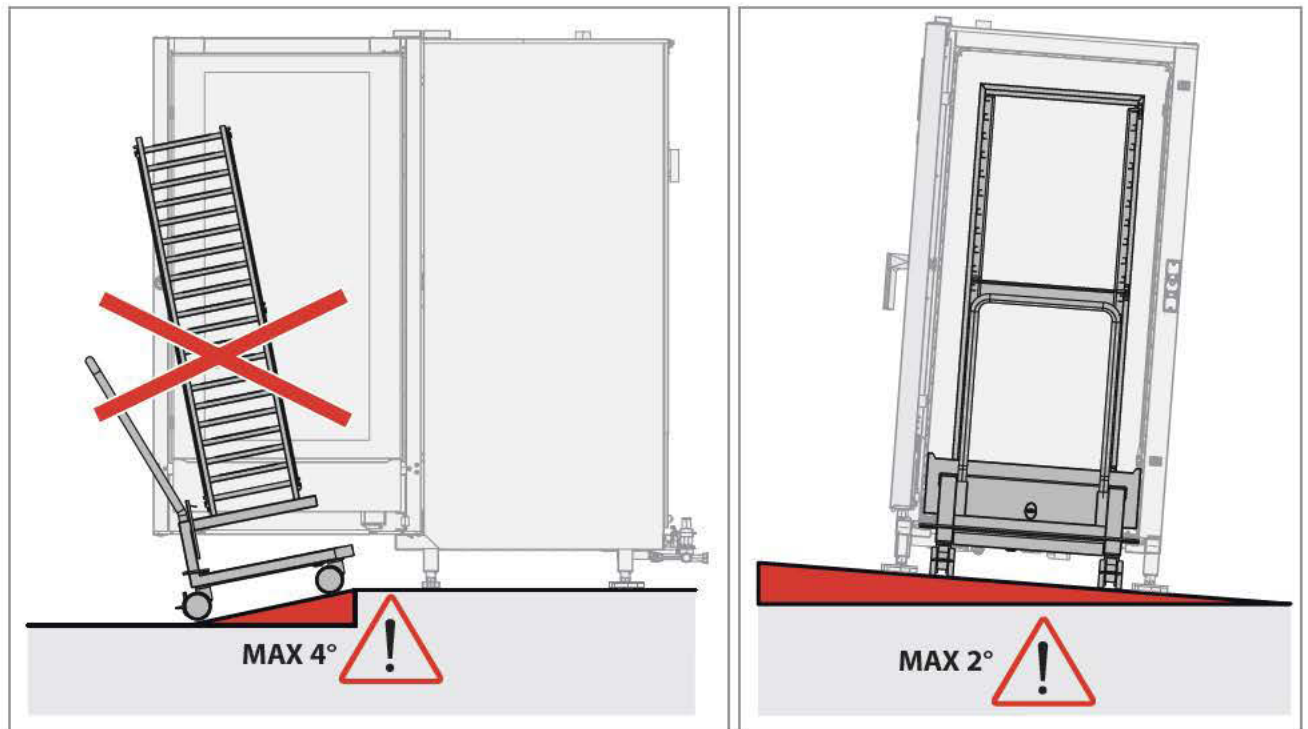

# TELESCOPIC SPACER

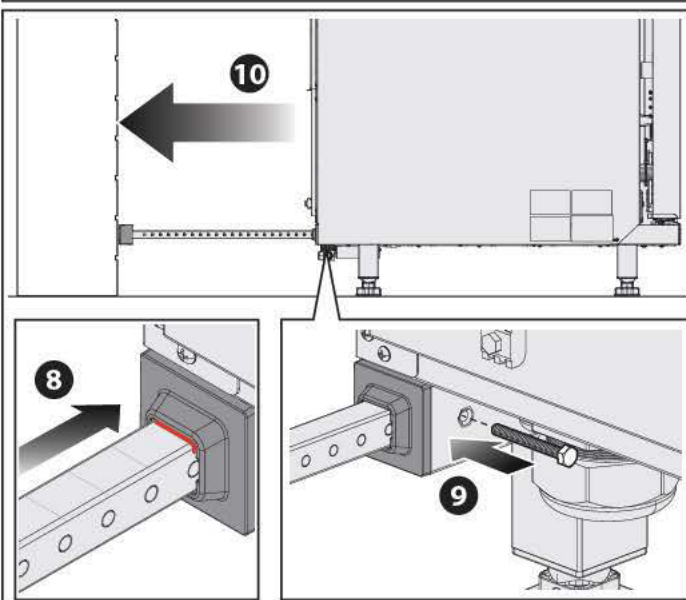
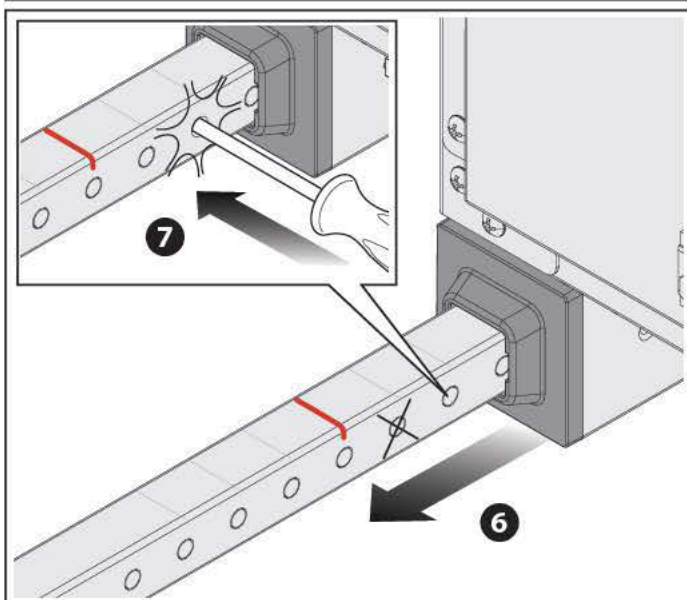
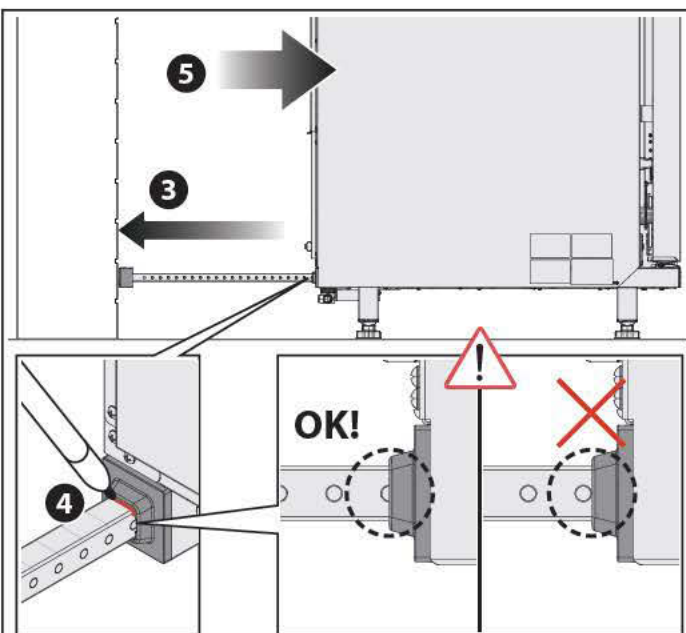
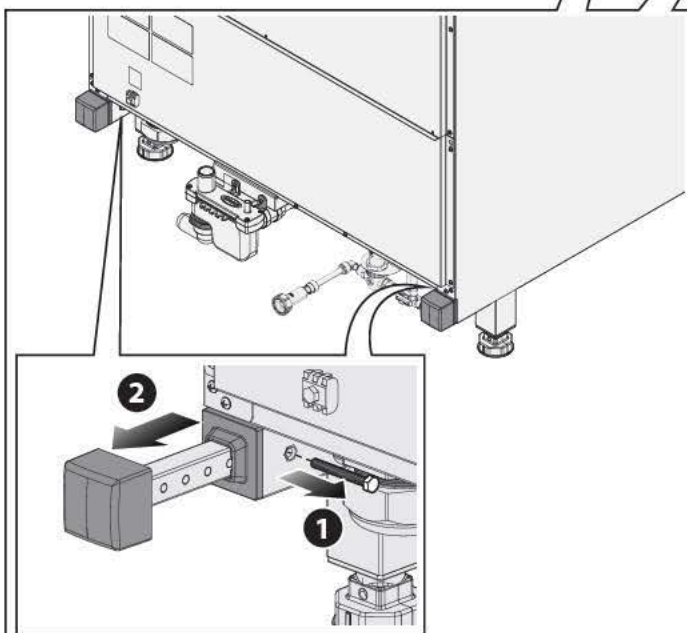
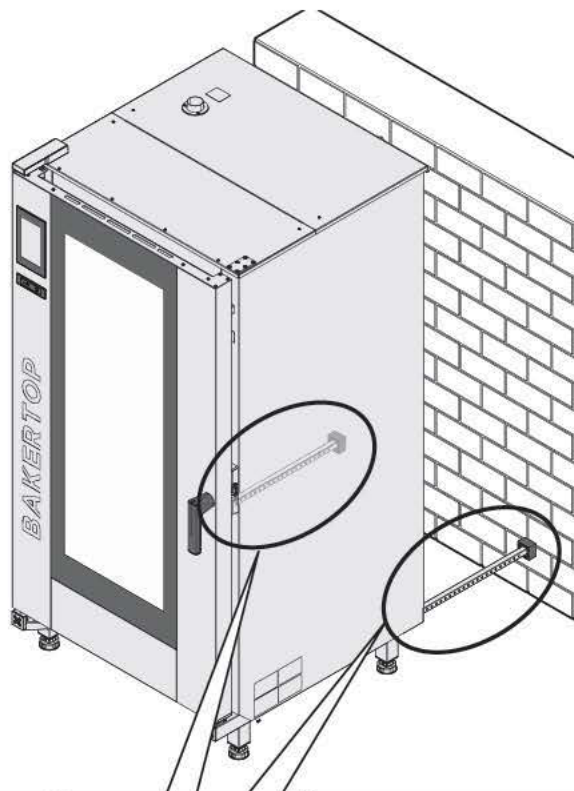

## DOOR CLOSURE ADJUSTMENT

After positioning the oven, proceed as follows if the door handle fails to close in the correct upright position:

- ① check that the appliance is level by using a spirit or digital level;
- ② - ⑦ if the appliance is level, adjust the closure latch as shown in the following diagrams. If the problem persists, repeat this procedure, loosening the latch fixing screws further.

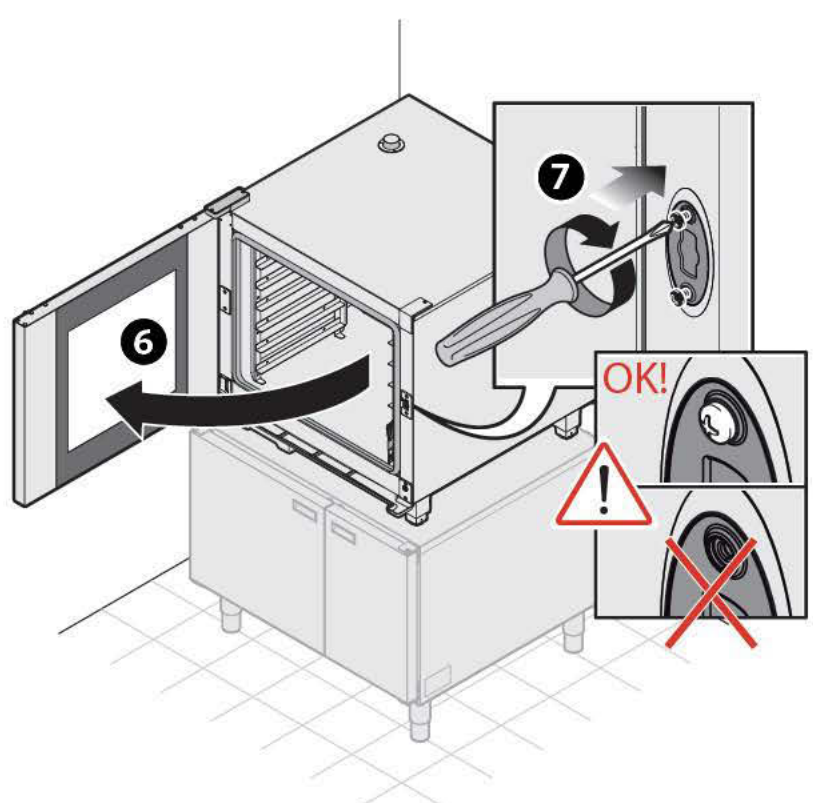
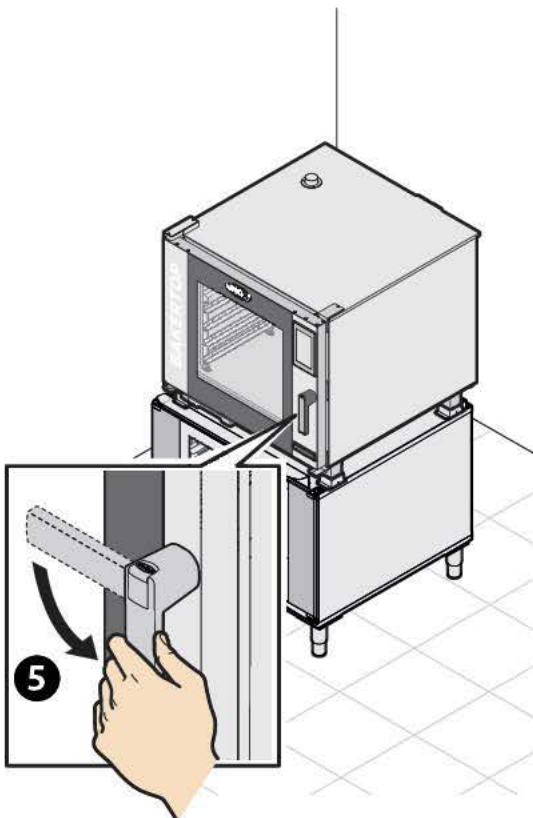
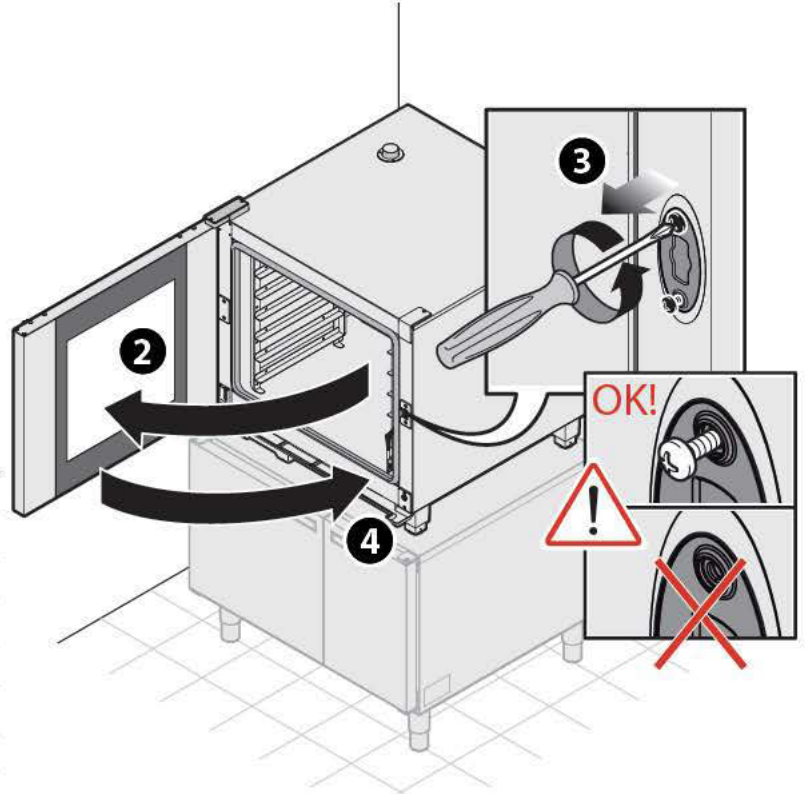
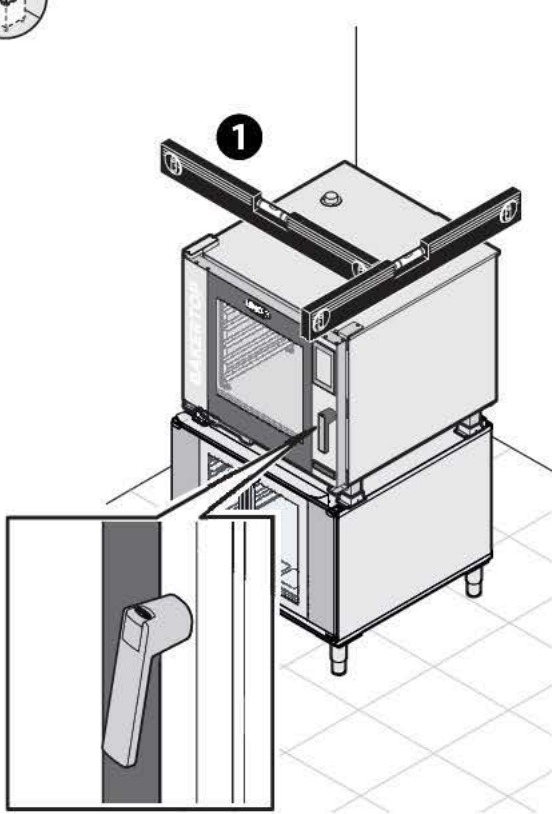

## 7 ELECTRICAL CONNECTION

 Before installing the appliance carefully read chapter "Safety regulations for installation" on page 5.

 Connections to the mains power and the electrical system must comply with the regulations in force in the country of installation of the appliance. All connections must be made by qualified personnel authorised by UNOX. Failure to comply with these regulations may cause damage and injuries, invalidates the guarantee and relieves UNOX of all liability.

 Before connecting the appliance to the mains electricity, always compare the power supply data with that of the appliance as specified on the rating plate.

 In order to avoid hazards due to the accidental resetting of the thermal cut-out, this appliance must not be powered with an external switching device, such as a timer, or be connected to a circuit that is regularly switched on and off by the utility.



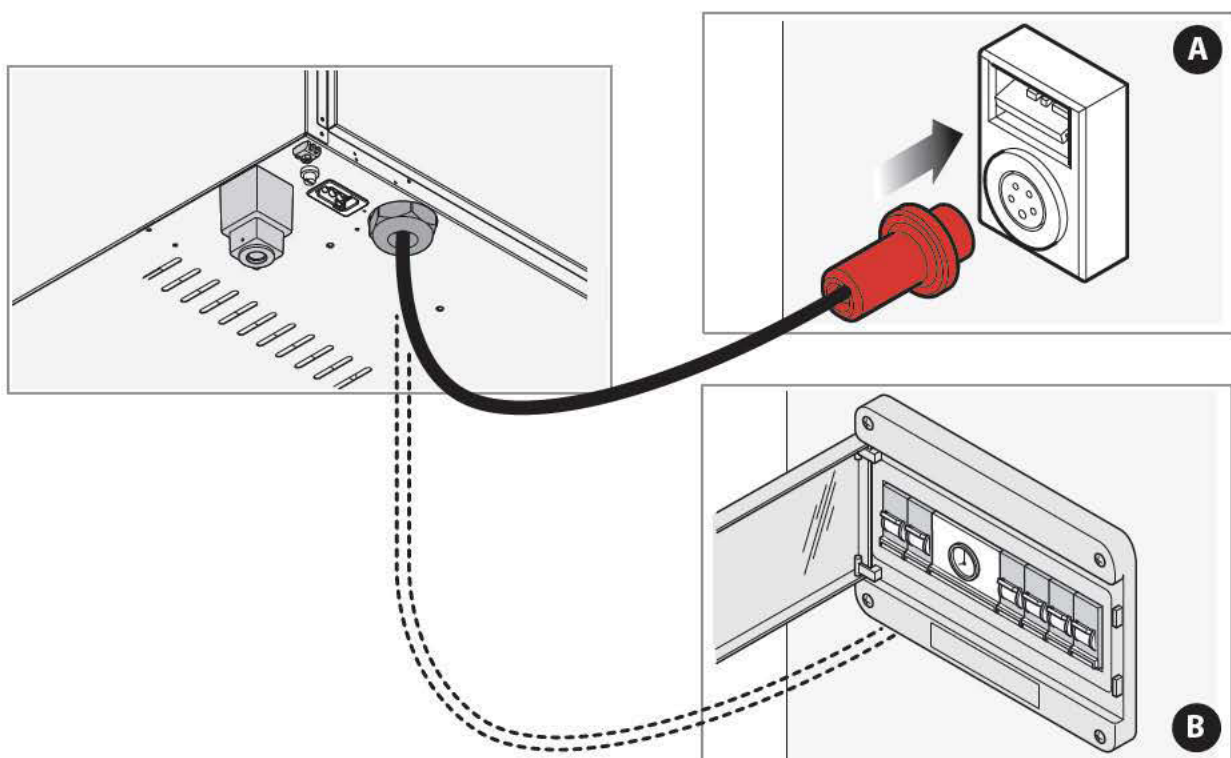

**COUNTERTOP OVENS** leave the factory with the power cable already installed on the terminal. Do not make any other type of electrical connection or any changes to the size of the cable, other than extending it or replacing it with a cable with the same specifications as the original (e.g. type of rubber and cross-section). All specifications are listed on the "Technical Specifications" sheet supplied with the appliance. To connect the electrics, fit a power plug (not supplied) of a suitable type and load for the maximum power absorbed by the oven's phases **A** (data available on the attached "Technical specifications" sheet). If this is not possible, the wiring supplied by UNOX is sufficient for connecting the appliance directly to the electrical board **B**.

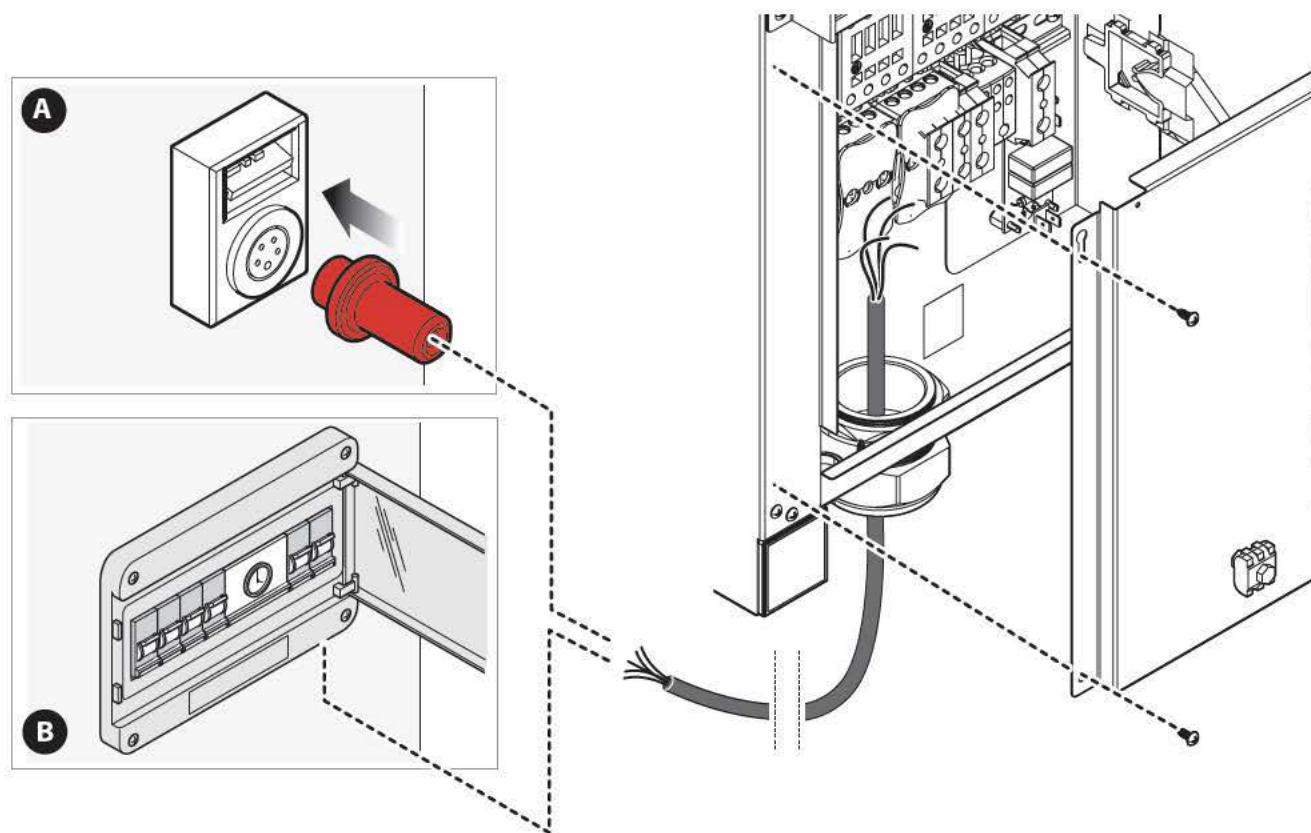

**FREE-STANDING “BIG” OVENS** do not have a power supply cable when they leave the factory. Remove the back panel on the appliance and connect a cable to the terminal board. The cable must have the characteristics specified in the “Technical specifications” sheet supplied with the appliance. Then fit a power plug (not supplied) of a suitable type and load for the maximum power absorbed by the oven’s phases **A** (data available on the attached “Technical specifications” sheet). If this is not possible, connect it to the electrical board **B**.



For countertop or free-standing ovens to be connected up correctly, they must:

- be wired into an **equipotential system** in accordance with current regulations. This connection must be made between different appliances with the terminal marked with the equipotential symbol . The cable must have a maximum cross-section of 10 mm<sup>2</sup> (as per CEI EN 60335-2-42:2003-09) and must be yellow/green.
- be connected to the mains **earth**  (yellow/green wire).
- be connected to a **thermal differential switch** in compliance with the regulations in force (0.03A, type A).
- be connected to an **all-pole circuit-breaker** that enables complete disconnection in category III over-voltage conditions.

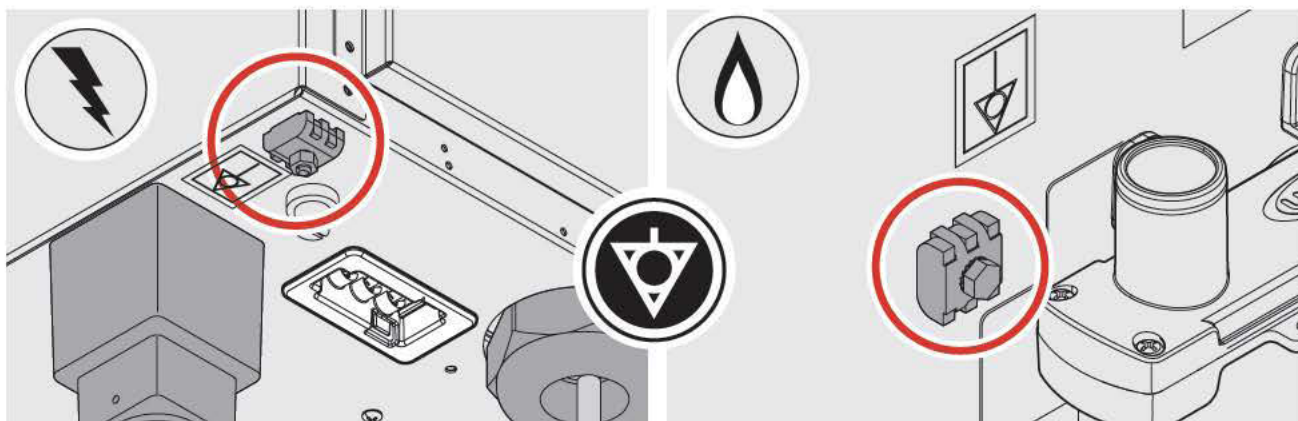

## CHECKS

- The copper jumper on the terminal board and the electrical cable must be secured together under the screw in its tightening direction, and the electrical connections must be securely tightened before connecting the appliance to the electricity mains.
- Check for any electrical dispersion between the phases and the earth, and for electrical continuity between the external casing and the mains earth.
- Check that the power supply voltage does not deviate from the nominal voltage value specified on the appliance rating plate when the appliance is operating. If it does, wire the phases as specified on the "Technical specifications" sheet supplied.

## ADAPTING TO DIFFERENT VOLTAGES

For electrical and voltage requirements that differ from standard values, replace the power supply cable and connect the new cable to the terminal board, following the diagrams on the "Technical specifications" sheet (Power supply - Connection Diagram) supplied with the appliance.

## REPLACING THE POWER SUPPLY CABLE

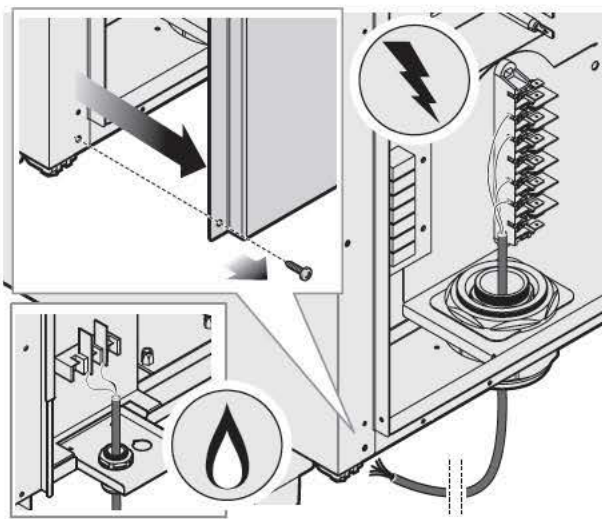

COUNTERTOP | XEVC - XECC - XEBC

**!** The cable must be replaced by UNOX, the UNOX technical assistance service or, in any case, by a person with a similar role in order to prevent any risks.

Follow the procedures below to replace the power supply cable:

- remove the rear oven panel and remove the cable by detaching it from the terminal block;
- see the "Technical specifications" sheet (Power supply - Connection Diagram) which shows all of the possible wiring diagrams and the new cable spec according to the chosen connection (Cable Type);
- secure the new cable using the cable clamp;
- close the rear panel of the oven.

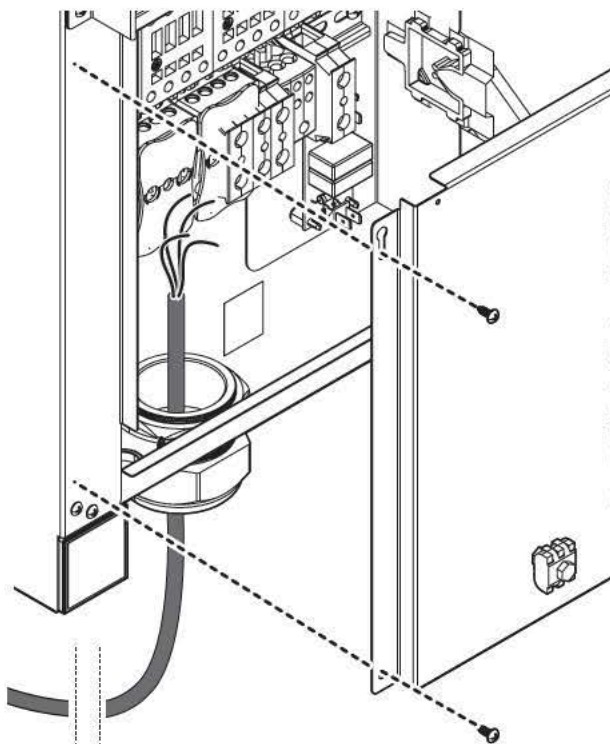

FREESTANDING OVENS | BIG XEVL - XECL - XEBL

## 8 GAS CONNECTIONS (ONLY FOR GAS OVENS)

 Before installing the appliance carefully read section “**Safety regulations for installation**” on page 5.

Only for Australia: This unit must be installed by a licensed person to AS/NZS5601 and local Regulations. Only authorized persons may install.

 Connections to the gas supply must comply with the regulations in force in the country of installation of the appliance; and all connections must be performed by qualified personnel authorised by UNOX. Failure to comply with these regulations may cause damage and injuries, invalidates the guarantee and relieves UNOX of all liabilities.

### | CONNECTING TO THE GAS UTILITY SYSTEM

The appliance is factory set, configured and tested to operate using:

- natural gas (G20)
- nominal pressure of the mains supply (entering the gas valve) of 5mbar-35mbar (0.5kPa-3.5kPa)
- maximum gas inlet pressure of 40mbar (4 kPa).
- maximum pressure drop at ignition = 5mbar.

Before connection, check that the available gas and pressure comply with the information above: this information is also shown on the “DATA PLATE GAS” plate attached to the side of the oven.

The female attachment for connection to the gas utilities is on the lower part of the oven: the connection must be done using a rigid or flexible pipe with a cut-off valve (not supplied) placed upstream of the appliance.

 Make sure that the gas tube does not run next to hot areas and that they are not subject to pulling, twisting or crushing.

 The gas supply system and all attachments must be up to code and respect the regulations in force in the country of use (for Australia: AS5601).

 Components sealed with red paint must never be tampered with!

 The oven can only be reset after a GAS error by holding down the “REARM” button on the screen and then the OK button.

 Special adjustments are not needed when using this appliance at high altitudes.

Gas supply tubing or hose shall comply with the national requirements in force and shall be periodically examined and replaced as necessary.

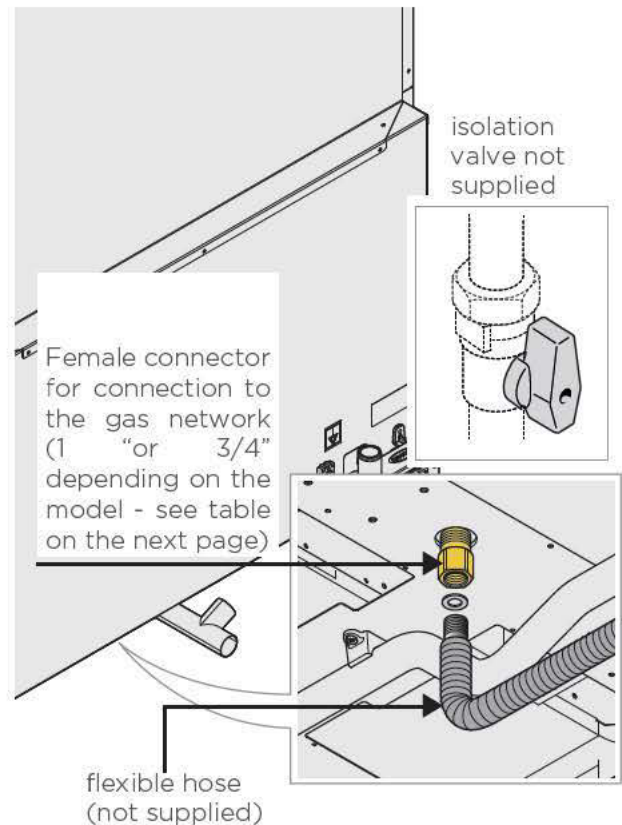

**TAB. 2. ► OVENS GAS CONSUMPTION AND MAXIMUM NOMINAL THERMAL LOAD**

CHEFTOP MIND.Maps™															
OVEN CODE	Female thread fitting	P MAX [kW]							P START [kW]						
		G110	G20	G25	G25.1	G25.3	G30	G31	G110	G20	G25	G25.1	G25.3	G30	G31
XEVC-0511-GPxM	3/4"	13,5	15	15	15	15	15	15	6,75	9,5	9	9,75	10,5	12	12,25
XEVC-0511-GPxM-MS	3/4"	13,5	15	15	15	15	15	15	6,75	9,5	9	9,75	10,5	12	12,25
XEVC-0621-GPxM	3/4"	19,5	27	25	23	25,5	27	27	9,5	15	17	20	17,5	23,5	21
XEVC-0711-GPxM	3/4"	14,5	19	19	19	19	19	19	8	7	7,25	8	7,5	12,25	10,5
XEVC-0711-GPxM-MS	3/4"	14,5	19	19	19	19	19	19	8	7	7,25	8	7,5	12,25	10,5
XEVC-1011-GPxM	3/4"	18	22	22	22	22	22	22	6,5	14,5	11,25	9,75	8,25	10,5	9,5
XEVC-1011-GPxM-MS	3/4"	18	22	22	22	22	22	22	6,5	14,5	11,25	9,75	8,25	10,5	9,5
XEVC-1021-GPxM	3/4"	31	42,5	38	37,5	40	42,5	42,5	12	29,5	23,5	25,75	30,5	30,25	29,5
XEVL-2011-GPxS	3/4"	39	48	48	48	48	48	48	32	40	40	38	40	46	45
XEVL-2021-GPxS	1"		90	86	86	86	90	90		50	45	47	46	47	46

OVEN CODE	Female thread fitting	P MIN [kW]							MAX GAS CONSUMPTION [m <sub>v</sub> /h]						
		G110	G20	G25	G25.1	G25.3	G30	G31	G110	G20	G25	G25.1	G25.3	G30	G31
XEVC-0511-GPxM	3/4"	4,25	5	5	4,75	6,25	6,75	6,75	3,674	1,601	1,873	1,850	1,850	0,463	0,614
XEVC-0511-GPxM-MS	3/4"	4,25	5	5	4,75	6,25	6,75	6,75	3,674	1,601	1,873	1,850	1,850	0,463	0,614
XEVC-0621-GPxM	3/4"	6,5	6,5	8,5	10,5	6,5	8,5	8	5,010	2,776	3,099	2,850	3,126	0,847	1,127
XEVC-0711-GPxM	3/4"	7	6	6,75	7,25	6	7	6,5	3,895	2,059	2,404	2,424	2,360	0,604	0,794
XEVC-0711-GPxM-MS	3/4"	7	6	6,75	7,25	6	7	6,5	3,895	2,059	2,404	2,424	2,360	0,604	0,794
XEVC-1011-GPxM	3/4"	6,5	5,75	5,5	6,5	5	5,5	6	4,654	2,269	2,697	2,729	2,665	0,686	0,900
XEVC-1011-GPxM-MS	3/4"	6,5	5,75	5,5	6,5	5	5,5	6	4,654	2,269	2,697	2,729	2,665	0,686	0,900
XEVC-1021-GPxM	3/4"	8,25	10,75	10,5	13,5	10	11	11,25	7,916	4,257	4,563	4,523	4,798	1,320	1,760
XEVL-2011-GPxS	3/4"	11	11A	10	12	10	18	15	10,065	5,079	5,908	5,898	5,775	1,824	2,406
XEVL-2021-GPxS	1"		23	22	22	22	26	25		9,524	10,585	10,567	10,348	3,420	4,511

OVEN CODE	Female thread fitting	MAX GAS CONSUMPTION [kg/h]						
		G110	G20	G25	G25.1	G25.3	G30	G31
XEVC-0511-GPxM	3/4"	-	-	-	-	-	0,961	0,952
XEVC-0511-GPxM-MS	3/4"	-	-	-	-	-	0,961	0,952
XEVC-0621-GPxM	3/4"	-	-	-	-	-	1,758	1,747
XEVC-0711-GPxM	3/4"	-	-	-	-	-	1,253	1,231
XEVC-0711-GPxM-MS	3/4"	-	-	-	-	-	1,253	1,231
XEVC-1011-GPxM	3/4"	-	-	-	-	-	1,423	1,395
XEVC-1011-GPxM-MS	3/4"	-	-	-	-	-	1,423	1,395
XEVC-1021-GPxM	3/4"	-	-	-	-	-	2,739	2,728
XEVL-2011-GPxS	3/4"	-	-	-	-	-	3,785	3,729
XEVL-2021-GPxS	1"	-	-	-	-	-	7,097	6,992

BAKERTOP MIND.Maps™															
OVEN CODE	Female thread fitting	P MAX [kW]							P START [kW]						
		G110	G20	G25	G25.1	G25.3	G30	G31	G110	G20	G25	G25.1	G25.3	G30	G31
XEBC-06EU-GP*	3/4"	16	19	19	19	19	19	19	11	15	15	15	15	17,5	17
XEBC-10EU-GP*	3/4"	20	25	24	23	21	25	25	14	17	17	16	15	19	16,5
XEBC-16EU-GP*	3/4"	23	35	31,5	31,5	31,5	35	35	16	21	20	20	20	23	23
XEVL-16EU-GP*S	3/4"	39	48	48	48	48	48	48	32	40	40	38	40	46	45

CODICE FORNO	Female thread fitting	P MIN [kW]							MAX GAS CONSUMPTION [m <sub>v</sub> /h]						
		G110	G20	G25	G25.1	G25.3	G30	G31	G110	G20	G25	G25.1	G25.3	G30	G31
XEBC-06EU-GP*	3/4"	6,5	5	6,5	6	6	7	6,5	4,129	2,011	2,338	2,340	2,286	0,589	0,777
XEBC-10EU-GP*	3/4"	6	6,5	8	8	6,5	8	9	5,161	2,646	2,954	2,833	2,527	0,775	1,023
XEBC-16EU-GP*	3/4"	8	9,5	9	9	10	11	11	5,935	3,704	3,877	3,880	3,790	1,085	1,432
XEVL-16EU-GP*S	3/4"	11	11	10	12	10	18	15	10,065	5,079	5,908	5,912	5,775	1,489	1,964

CODICE FORNO	Female thread fitting	MAX GAS CONSUMPTION [kg/h]						
		G110	G20	G25	G25.1	G25.3	G30	G31
XEBC-06EU-GP*	3/4"						1,479	1,458
XEBC-10EU-GP*	3/4"						1,946	1,918
XEBC-16EU-GP*	3/4"						2,725	2,685
XEVL-16EU-GP*S	3/4"						3,737	3,683

**TAB. 3. ► EUROPEAN GASES AND CORRESPONDING AUSTRALIAN AND NEW ZEALAND GASES**

EUROPEAN	AUSTRALIAN	MINIMUM PRESSURE AT THE GAS OVENS INLET (KPA)
G20	NATURAL GAS (N GAS)	1,13
G30	BUTANE (Y GAS)	2,75
G31	PROPANE (X GAS)	2,75

**TAB. 4. ► NOMINAL GAS CONSUMPTIONS UNOX GAS OVENS (MJ/H) GASES**

MODEL	NATURAL GAS (MJ/H)	LPG UNIVERSAL LP GAS (MJ/H)
XEVC- <b>05</b> 11-GPxM	54	54
XEVC- <b>05</b> 11-GPxM-MS	54	54
XEVC- <b>07</b> 11-GPxM	68,4	68,4
XEVC- <b>07</b> 11-GPxM-MS	68,4	68,4
XEVC- <b>06</b> EU-GPxM	68,4	68,4
XEVC- <b>10</b> 11-GPxM	79,2	79,2
XEVC- <b>10</b> 11-GPxM-MS	79,2	79,2
XEVC- <b>06</b> 21-GPxM	86,4	86,4
XEVC- <b>10</b> EU-GPxM	90	90
XEVC- <b>20</b> 11-GPxM	126	126
XEVC- <b>10</b> 21-GPxM	126	126
XEVL- <b>20</b> 11-GPxS	172,8	172,8
XEBL- <b>16</b> EU-GPxS	172,8	172,8
XEVL- <b>20</b> 21-GPxS	324	324

# 9 PLUMBING CONNECTIONS

## | PLUMBING: WATER SUPPLY

The rear of the appliance contains:

- 1.5 meters of hose, mechanical filter, pressure reducer and (3/4") fitting with non-return valve for plumbing. Before connecting the water pipe to the appliance, flush it out with water in order to eliminate any residue which may be accumulated inside. An isolation valve should be positioned between the water mains and the appliance;
- two attachments for connecting additional water treatment accessories (**UNOX.Pure** or **UNOX.Pure-RO**). To connect the attachments, please follow the instructions on the accessory package. Do not use ion-exchange resin water softeners.
- a pipe to supply detergent to clean the oven cavity (where applicable);

**+** To facilitate water connection for multiple column installations (**MAXI.Link**), use the "T" connection in the UNOX stacking kit.

**!** Use the set of new connections supplied with the appliance for the connection to the water mains. Connections that have already been used must not be used again.

### COUNTERTOP | XEVC - XECC - XEBC

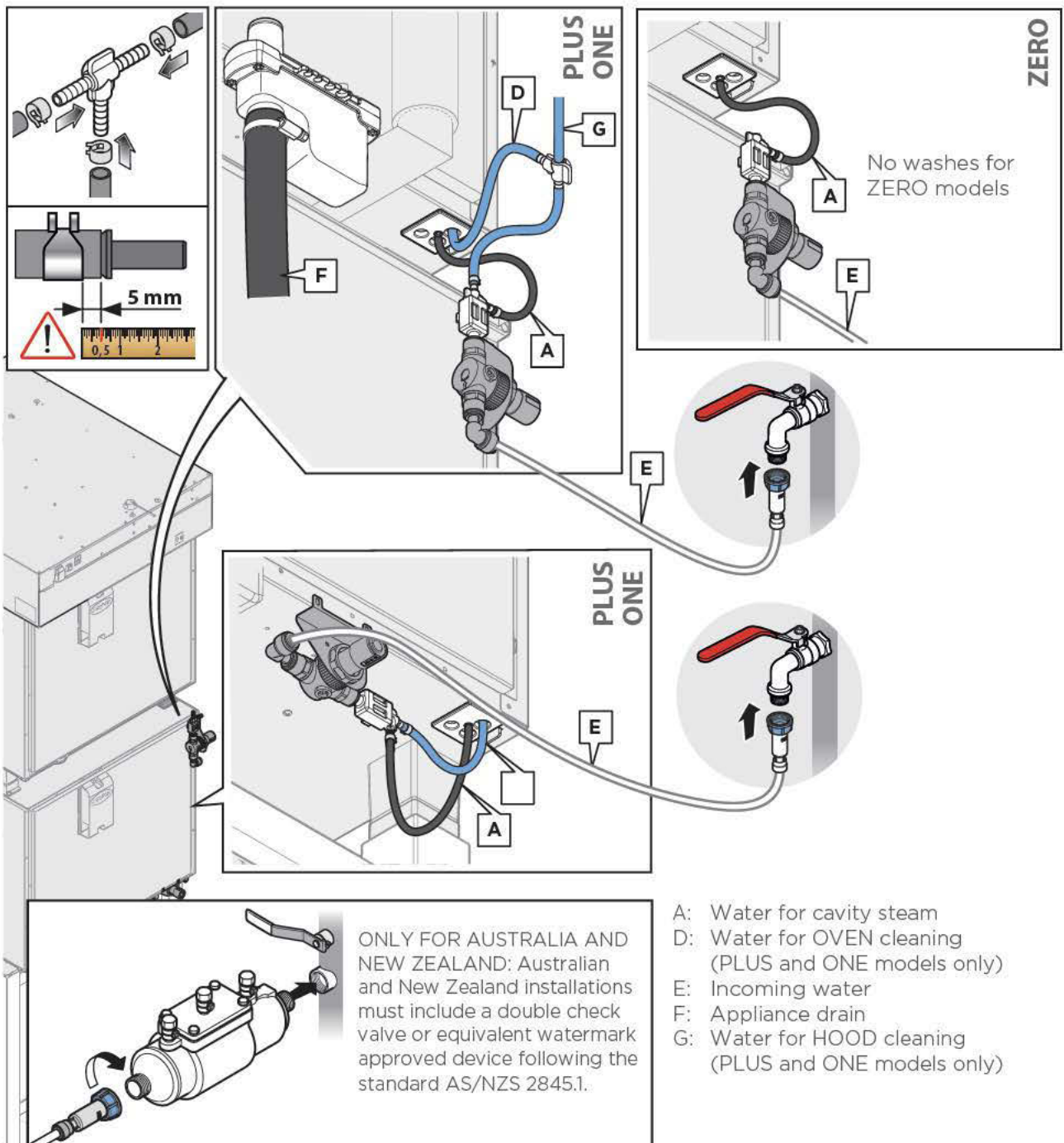

- A: Water for cavity steam
- D: Water for OVEN cleaning (PLUS and ONE models only)
- E: Incoming water
- F: Appliance drain
- G: Water for HOOD cleaning (PLUS and ONE models only)
- H Detergent pipe

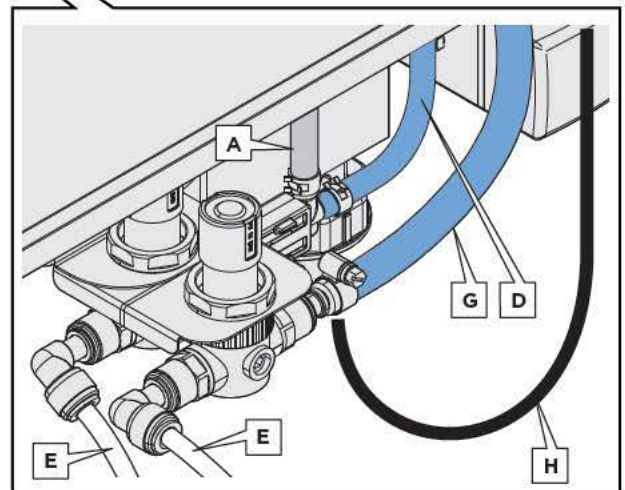
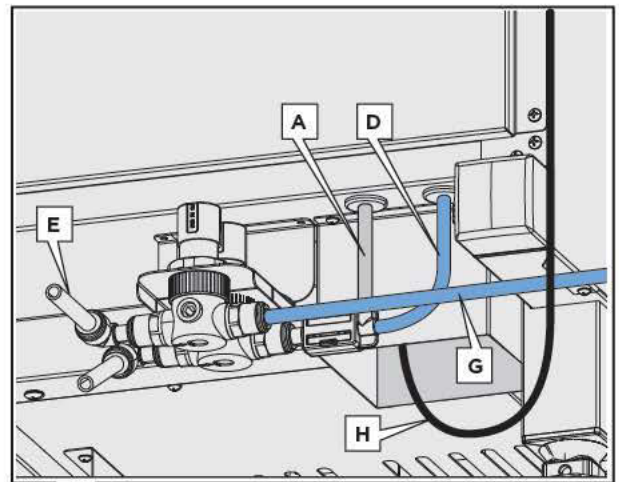
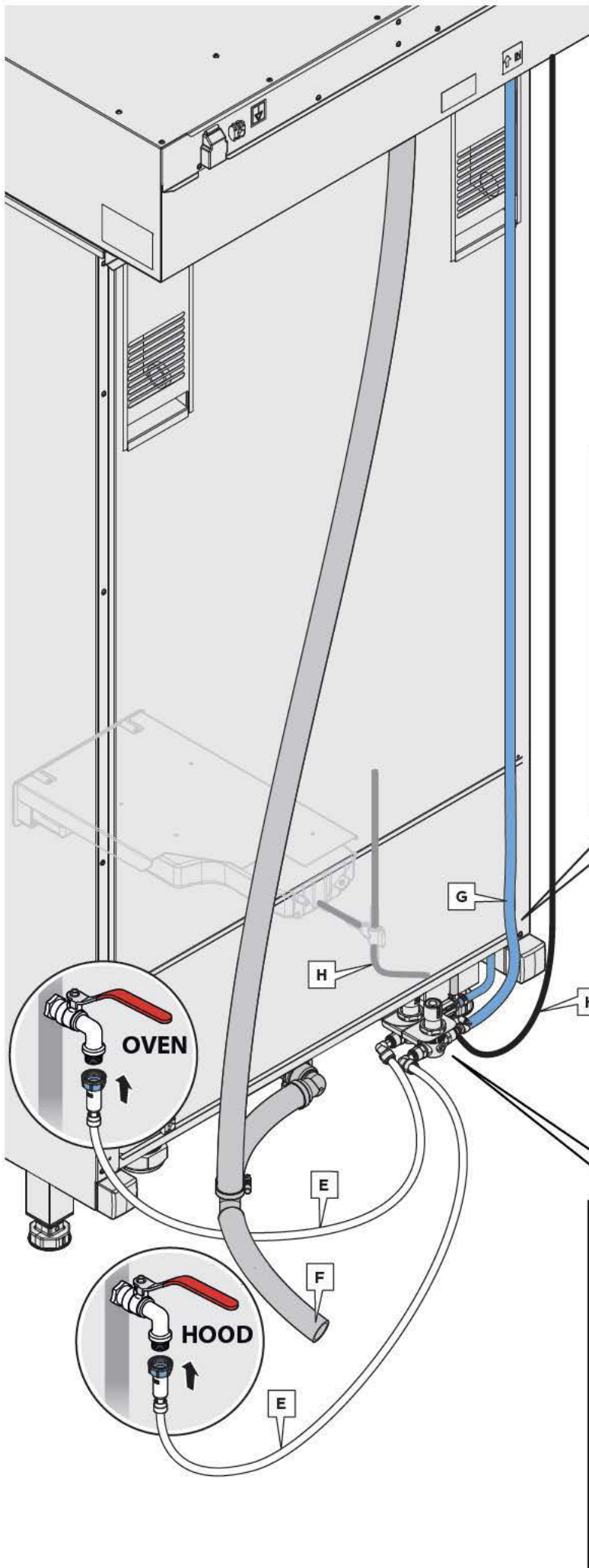

EN

## INCOMING WATER CHARACTERISTICS

The incoming water characteristics depend on the kind of stainless steel used in the cooking chamber: **AISI304** or **AISI316L**.

Some common incoming water characteristics are:

- maximum temperature of **30°C**;
- be drinkable;
- minimum pressure **150 kPa**; maximum pressure **600 kPa**; recommended pressure **200 kPa** (all CHEFTOP-BAK-ERTOP MIND.Maps™ ovens come with an integrated pressure reducer as standard).
- minimum flow rate: **300 l/h**;
- maximum water conductivity of **1000 µS/cm**. If the water conductivity exceeds 1000 µS/cm, the water used for producing steam must be treated.

In addition to these characteristics, the incoming water must respect all the parameters specified below. It is the responsibility of the purchaser to ensure that the incoming water supply is compliant with the listed specifications through adequate treatment measures.

Using a water supply that does not meet Unox's minimum water quality standards will void any warranty.

### XEVC, XECC AND XEBC OVENS WITH AISI 304 COOKING CAVITY

#### Line pressure

- Drinking water inlet: 3/4" NPT\*
- Line pressure: 22 to 87 psi; 1.5 to 6 Bar (29 psi; 2 Bar recommended)

#### Inflow water specifications

- Free chlorine ≤ 0.5 ppm
- Chloramine ≤ 0,1 ppm (mg/L)
- pH 7 ÷ 8,5
- Electrical conductivity ≤ 1000 µS/cm
- Total hardness (TH) ≤ 30 °dH
- Chlorides\* ≤ 120 ppm\*\*

#### Steam circuit: inflow water specifications

- Total hardness (TH) ≤ 8 °dH \*
- Chlorides\* ≤ 25 ppm\*\*

\*this value refers to daily steam cooking of 1- 2 hours. In any case, if with a total hardness ≤ 8°dH there is still production of limescale, it is mandatory to treat the water in order to avoid limescale production. We recommend water treatment systems based on ion exchange resins. Water treatment systems based on polyphosphates are not allowed. The total hardness can be measured using the [KSTR1082A](#) kit or with equivalent tools

\*\* The maximum chloride content, Cl-, is not a fixed value; it depends on the calculated Non Hardness Measurement (NHM)

#### NHM = EC - (TH\*\* x 30)

EC = electrical conductivity [µS/cm]

TH = total hardness\*\* [° dH - German degrees]

NHM ≤ 250 µS/cm	TH < 8 °dH, Cl- ≤ 25 ppm (5 drops of reagent*)	No water treatment
	TH ≥ 8 °dH, Cl- ≤ 25 ppm (5 drops of reagent*)	UNOX.Pure
	Cl- > 25 ppm (5 drops of reagent*)	UNOX.Pure-RO
NHM = 250 - 350 µS/cm	Cl- ≤ 20 ppm (4 drops of reagent*)	UNOX.Pure
	Cl- > 20 ppm (4 drops of reagent*)	UNOX.Pure-RO
NHM = 350 - 450 µS/cm	Cl- ≤ 15 ppm (3 drops of reagent*)	UNOX.Pure
	Cl- > 15 ppm (3 drops of reagent*)	UNOX.Pure-RO
NHM = 450 - 500 µS/cm	Cl- ≤ 10 ppm (2 drops of reagent*)	UNOX.Pure
	Cl- > 10 ppm (2 drops of reagent*)	UNOX.Pure-RO
NHM ≥ 500 µS/cm		UNOX.Pure-RO

\* use the reagent in the UNOX [KSTR1081A](#) kit    \*\* hardness measured using the UNOX [KSTR1082A](#) kit

If you need to install an UNOX.Pure-RO, please take note of the following information:

	1 UNOX.Pure-RO osmosis filter	2 parallel UNOX.Pure-RO osmosis filters	
1 motor	√		
2 motors	< 15 °dH < 450 µS/cm	> 15 °dH	> 450 µS/cm
3 motors	< 10 °dH < 300 µS/cm	> 10 °dH	> 300 µS/cm

## XEVC, BIG XEVL, BIG COMPACT XECL OVENS WITH AISI 316L COOKING CAVITY

### ► Line pressure

- Drinking water inlet: 3/4" NPT\*
- Line pressure: 22 to 87 psi; 1.5 to 6 Bar (29 psi; 2 Bar recommended)

### ► Inflow water specifications

- Free chlorine ≤ 0.5 ppm
- Chloramine ≤ 0,1 ppm (mg/L)
- pH 7 ÷ 8,5
- Electrical conductivity: 1000 µS/cm
- Total hardness (TH) ≤ 30 °dH

### ► Steam circuit: inflow water specifications



- Total hardness (TH) ≤ 8 °dH \*
- Chlorides\* ≤ 250 ppm

\*this value refers to daily steam cooking of 1- 2 hours. In any case, if with a total hardness ≤ 8°dH there is still production of limescale, it is mandatory to treat the water in order to avoid limescale production. We recommend water treatment systems based on ion exchange resins. Water treatment systems based on polyphosphates are not allowed. The total hardness can be measured using the KSTR1082A kit or with equivalent tools

To avoid the formation of **limescale**, the incoming water must have the following chemical/physical characteristics:

- Total hardness (TH) ≤ 8°dH

If the total hardness is above 8°dH, treat the water according to the following table:

OVENS	TREATMENT XHC003 UNOX. Pure XHC004 refill
<ul style="list-style-type: none"> <li>XEVC-0511-EPxM-MS</li> <li>XEVC-0711-EPxM-MS</li> <li>XEVC-1011-EPxM-MS</li>   <li>XEVC-0511-GPxM-MS</li> <li>XEVC-0711-GPxM-MS</li> <li>XEVC-1011-GPxM-MS</li>   <li>BIG XEVL-2011-E1xS</li> <li>BIG XEBL-16EU-E1xS</li> <li>BIG COMPACT XECL-2013-E1xS</li> </ul>	  1 piece
<ul style="list-style-type: none"> <li>BIG XEVL-2011-YPxS</li> <li>BIG XEVL-2011-DPxS</li> <li>BIG XEVL-2021-YPxS</li> <li>BIG XEVL-2021-DPxS</li>   <li>BIG XEBL-16EU-YPxS</li> <li>BIG XEBL-16EU-DPxS</li> <li>BIG XEVL-2011-GPxS</li> <li>BIG XEVL-2021-GPxS</li> <li>BIG XEBL-16EU-GPxS</li>   <li>BIG COMPACT XECL-2013-YPxS</li> </ul>	  2 parallel pieces + KEL1115A (Tee attachment JG 8 mm)

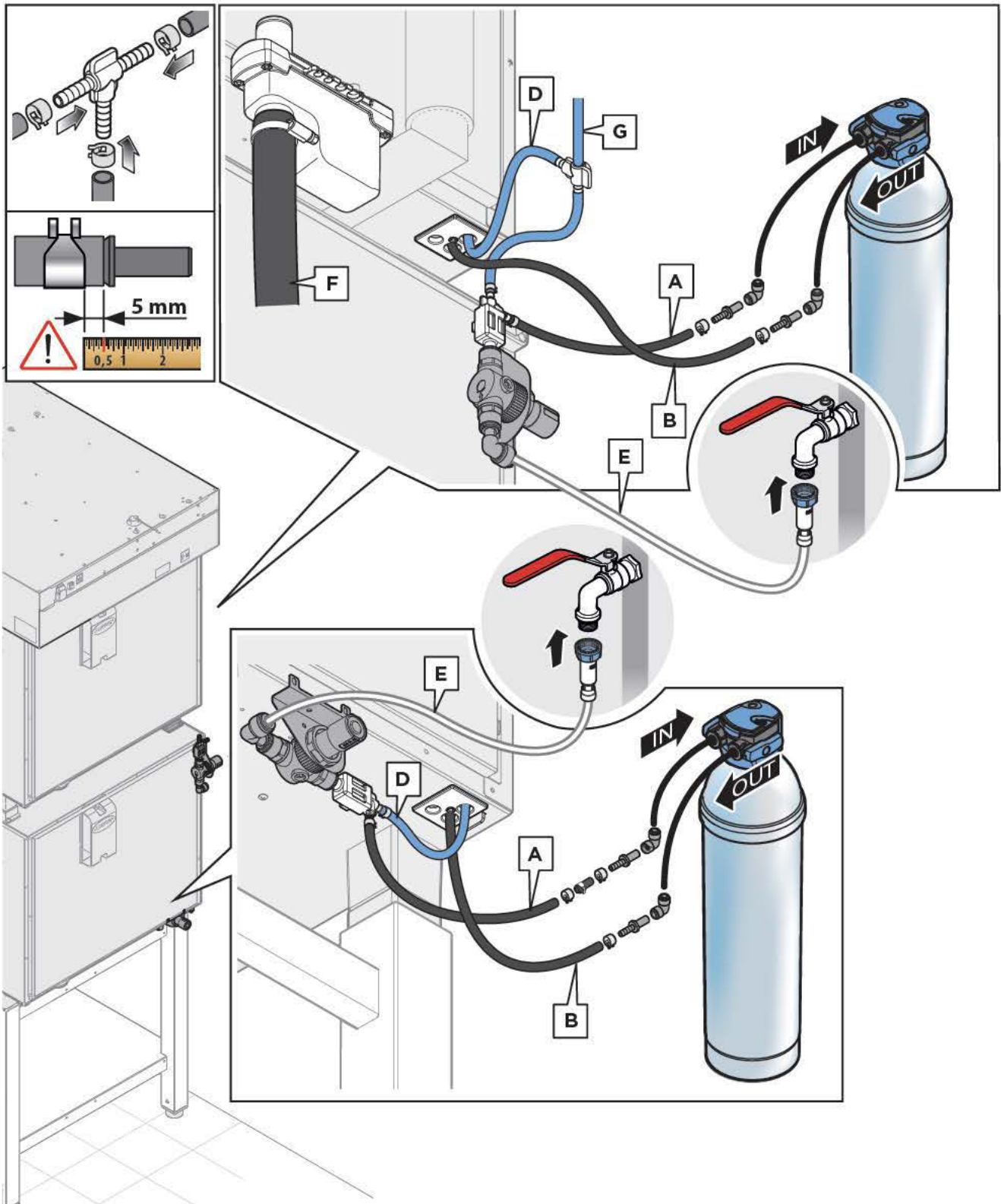

- A: Water to be treated
- B: Water for cavity steam - treated
- D: Water for OVEN cleaning (PLUS and ONE models only)
- E: Incoming water
- F: Appliance drain
- G: Water for HOOD cleaning (PLUS and ONE models only)

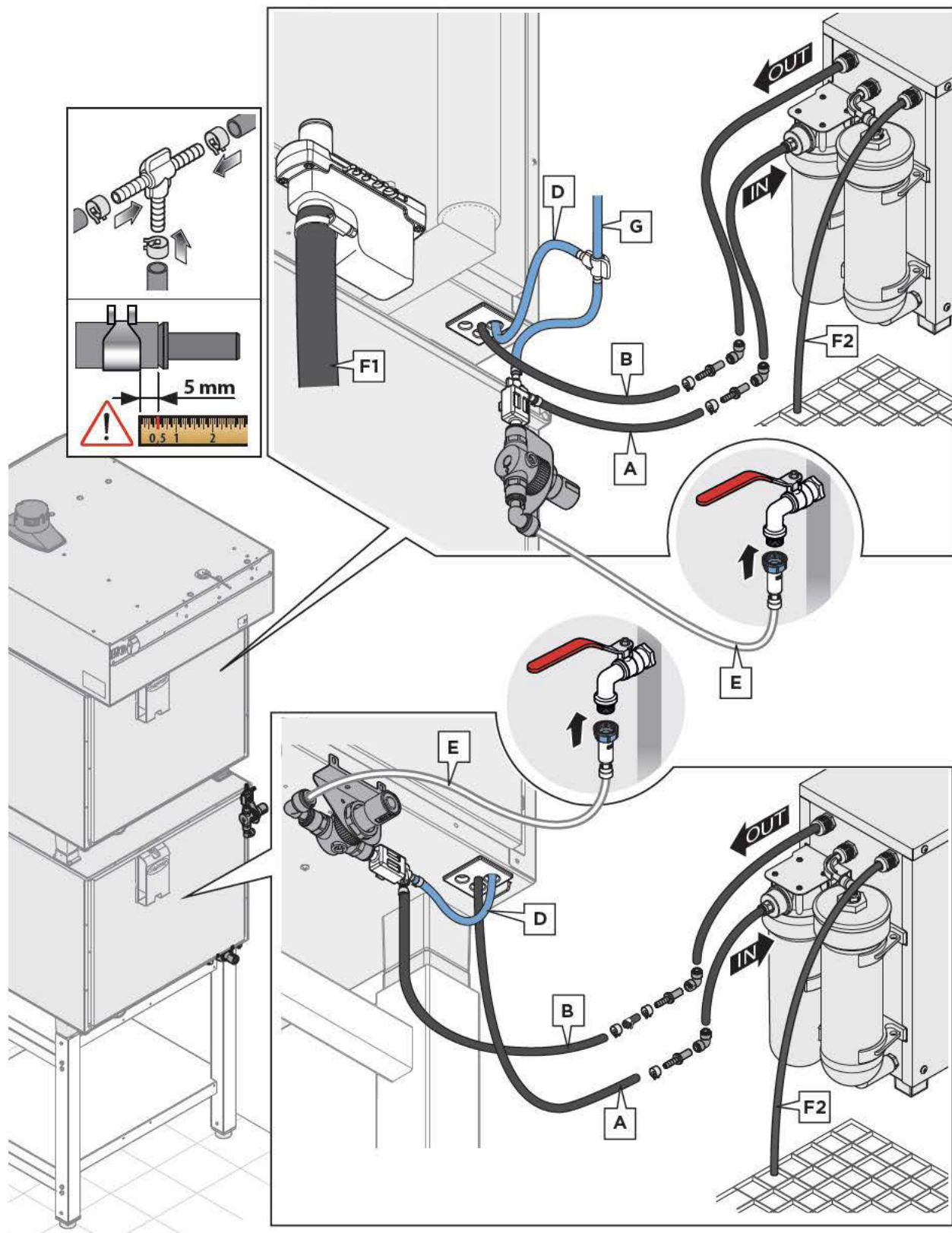

- A: Water to be treated
- B: Water for cavity steam - treated
- C: Connection to the detergent tank (PLUS and ONE models only)
- D: Water for cleaning - untreated (PLUS and ONE models only)
- E: Incoming water
- F1: Appliance drain
- F2: UNOX.Pure-RO drain
- G: Water for HOOD cleaning (PLUS and ONE models only)

- A: Water for cavity steam
- D: Water for OVEN cleaning (PLUS and ONE models only)
- E: Incoming water
- F: Appliance drain
- G: Water for HOOD cleaning (PLUS and ONE models only)
- H Detergent pipe

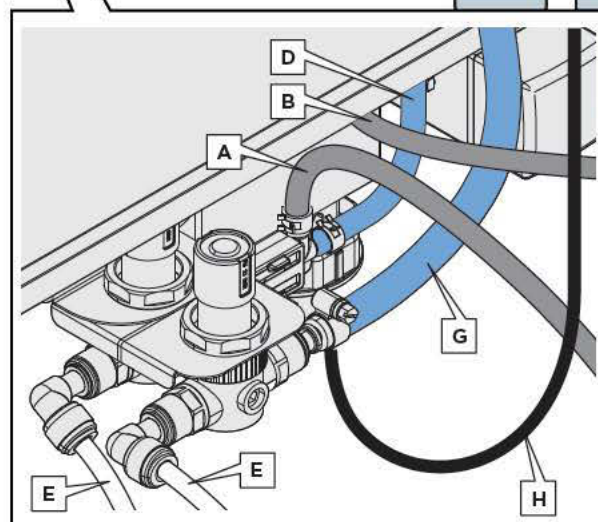
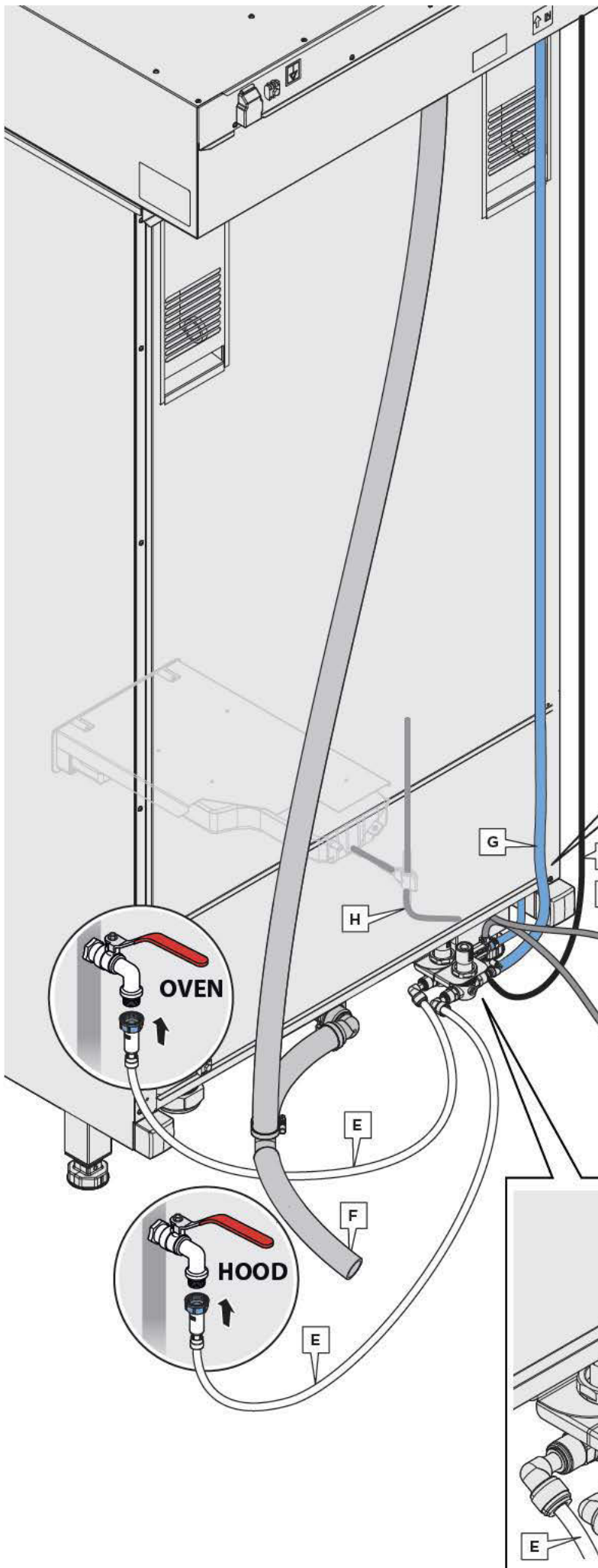
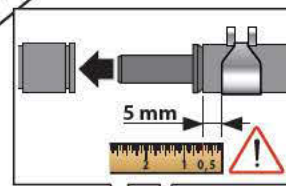
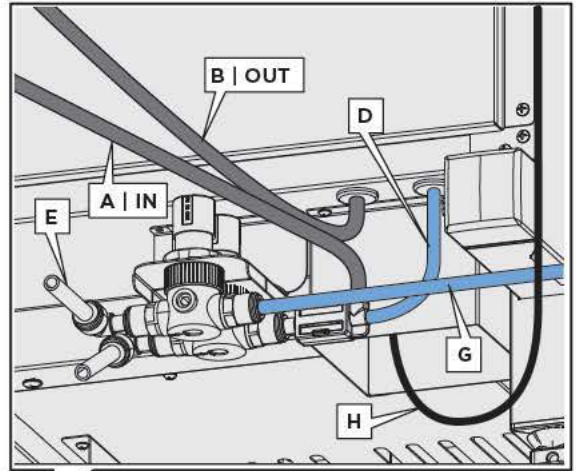

## PLUMBING: DRAINAGE

The drain is located:

- on the bottom of counter top ovens;
- on the back of free-standing ovens with or without trolley.

Connect the bend/siphon to a rigid pipe or flexible hose and connect the assembly to waste water drainage in accordance with local water regulations.

**+** Unox recommends its proprietary rigid pipes and flexible hoses.

**!** **The waste water draining from the oven may be hot (90°C). The pipes used for water drainage must be able to withstand high temperatures and not be made of metal.**

**+** If it is necessary to lower the temperature of the waste water, UNOX recommends its waste water cooling kit.

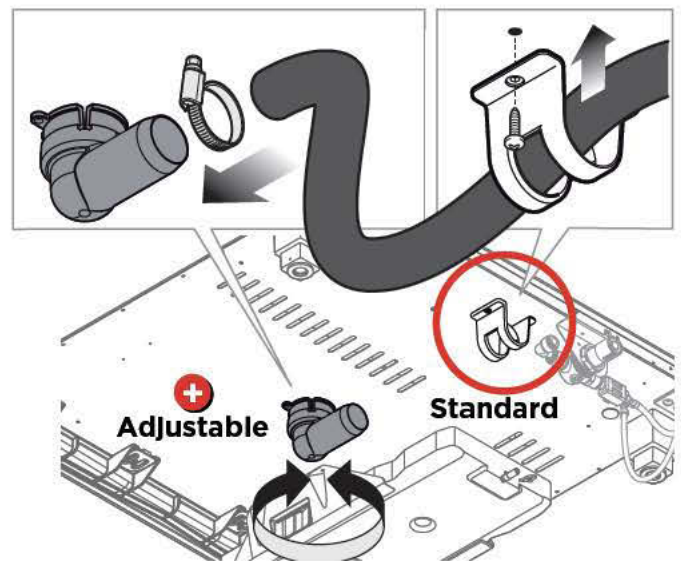
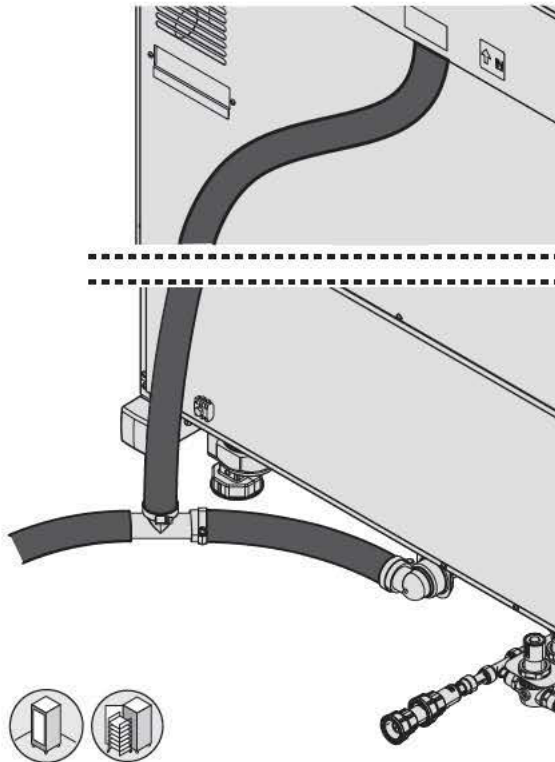

If the **BAKERTOP MIND.Maps™** oven cannot be permanently connected to a drainage system, the terminal must be sealed with the conical plug provided in the "Starter kit".

Remove elbow fitting by unscrewing the supporting screws and place the conical plug in the drainage terminal.

**!** When the drain is blocked, DO NOT use the washing programs or wash the cavity with large quantities of water. Risk of flooding.

**!** If cooking large amounts of greasy foods, remove the siphon and add a grease separator or discharge directly into the grate. Keep the indicated air gap in both cases.

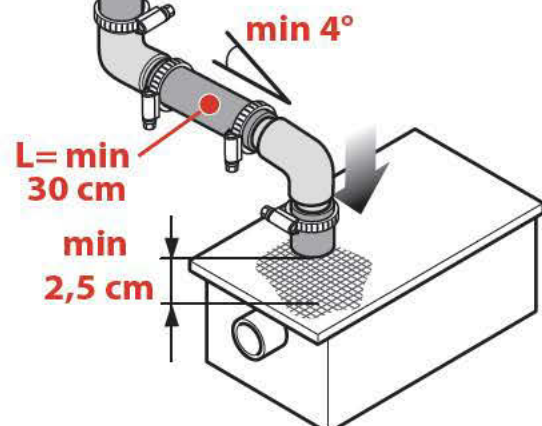
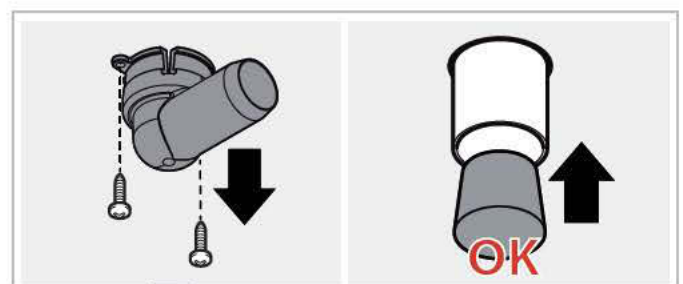

## | DRAINAGE SPECIFICATIONS

The drainage system must:

- be a siphon-type;
- be one meter in length maximum;
- have a minimum incline of 4%;
- have a diameter that is NOT less than the drain pipe attachment;
- be free of kinks and sharp ends;
- be dedicated to each appliance; if this is not the case, make sure that the main drainage pipe is sized sufficiently to ensure that water flows away properly without any problems.

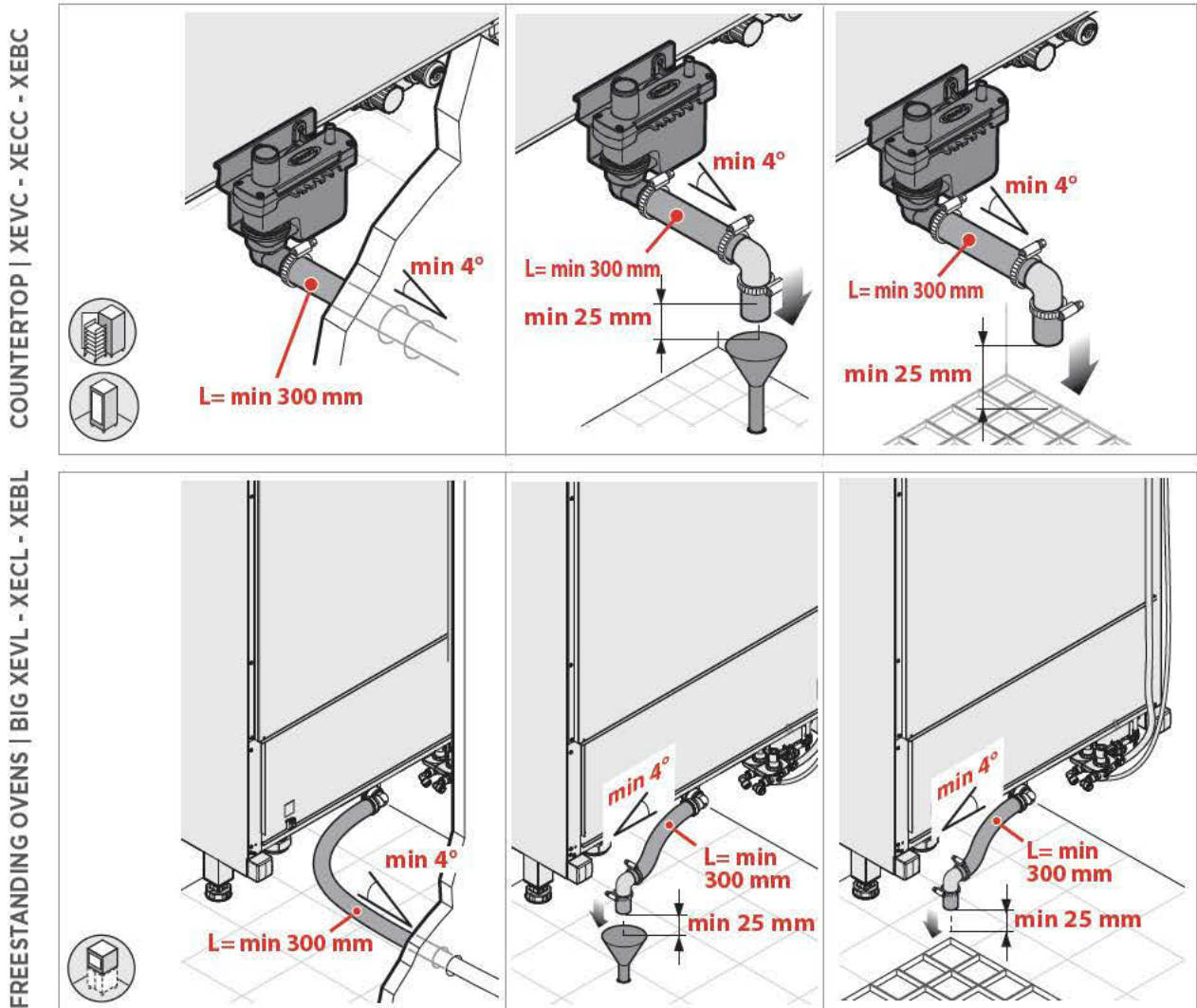

(1): The wall-mounted exhaust output must have an air gap of at least 25 mm.

## | SIPHON FILLING

After installation, pour at least 0.5 l (0.132 gal) in the drain in the oven cooking chamber until the siphon is filled.

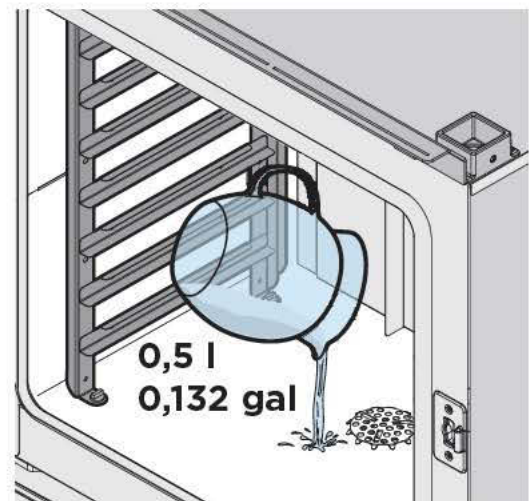

COUNTERTOP | XEVC - XECC - XEBC

Example of plumbing in **MAXI.Link** columns

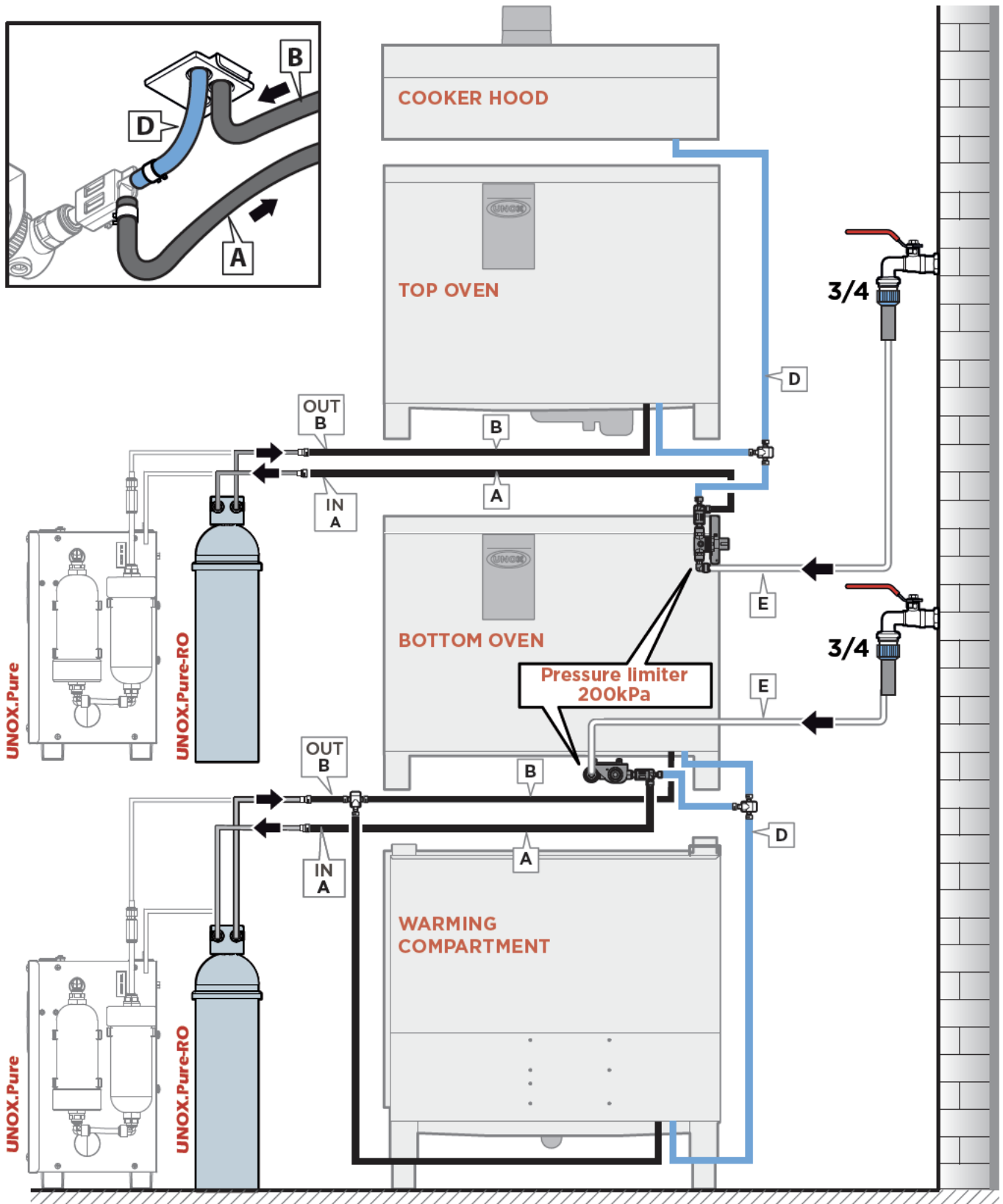

- A: Water to be treated
- B: Water for cavity steam - treated
- D: Water for cleaning - untreated (PLUS and ONE models only)
- E: Incoming water
- F: Appliance drain
- G: Water for HOOD cleaning (PLUS and ONE models only)

COUNTERTOP | XEVC - XECC - XEBC

Example of plumbing in **MAXI.Link** columns

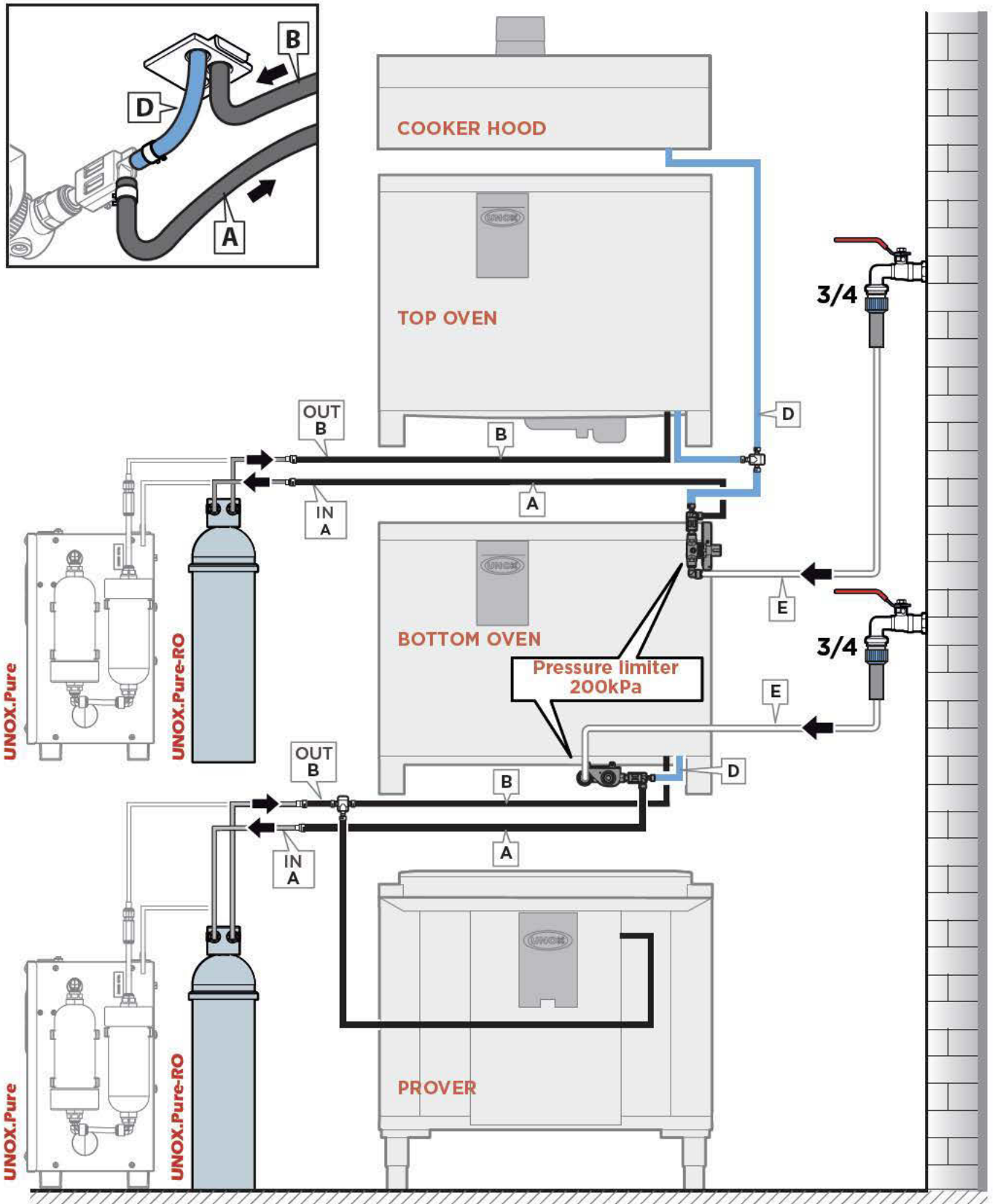

- A: Water to be treated
- B: Water for cavity steam - treated
- D: Water for cleaning - untreated (PLUS and ONE models only)
- E: Incoming water
- F: Appliance drain
- G: Water for HOOD cleaning (PLUS and ONE models only)

COUNTERTOP | XEVC - XECC - XEBC  
 Example of plumbing in **MAXI.Link** columns

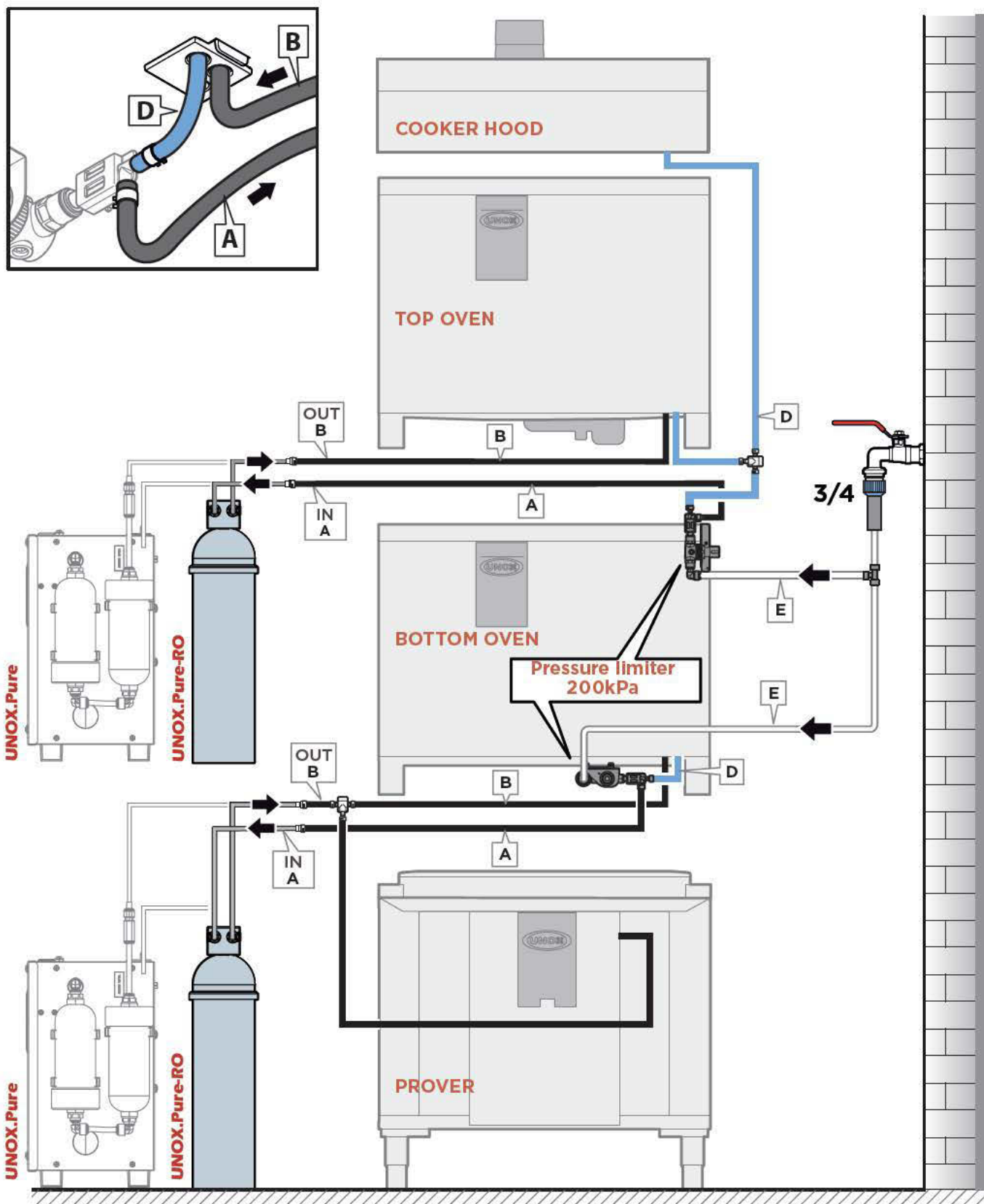

- A: Water to be treated
- B: Water for cavity steam - treated
- D: Water for cleaning - untreated (PLUS and ONE models only)
- E: Incoming water
- F: Appliance drain
- G: Water for HOOD cleaning (PLUS and ONE models only)

**FREESTANDING OVENS | BIG XEVL - XECL - XEBL**  
 Example of plumbing in **MAXI.Link** columns

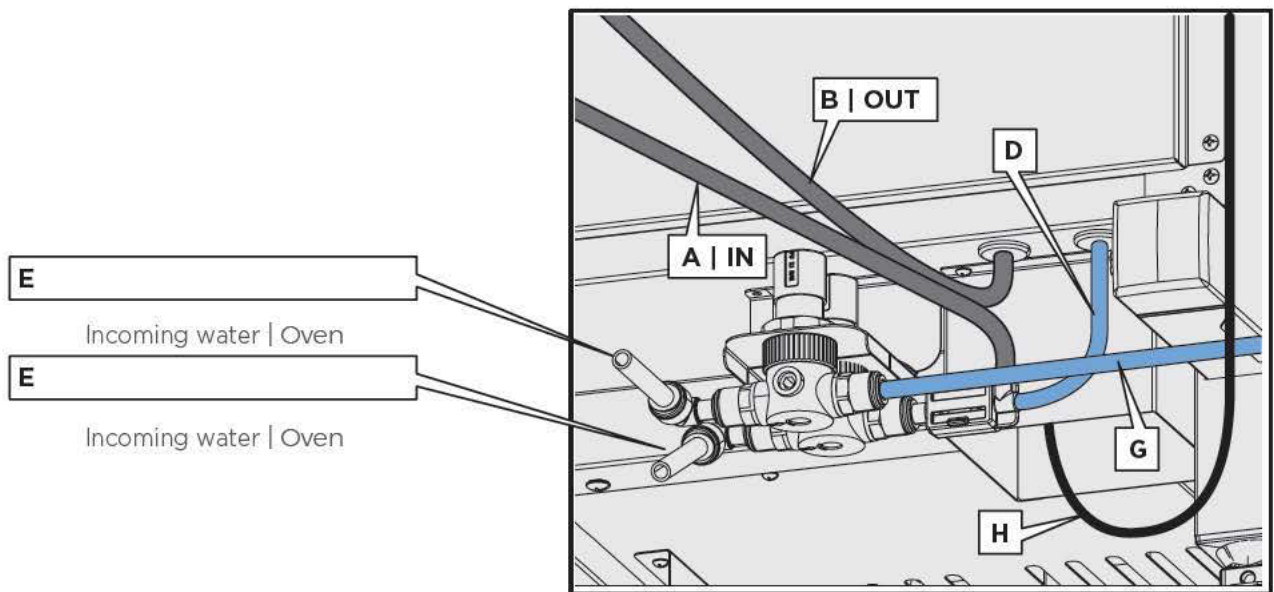
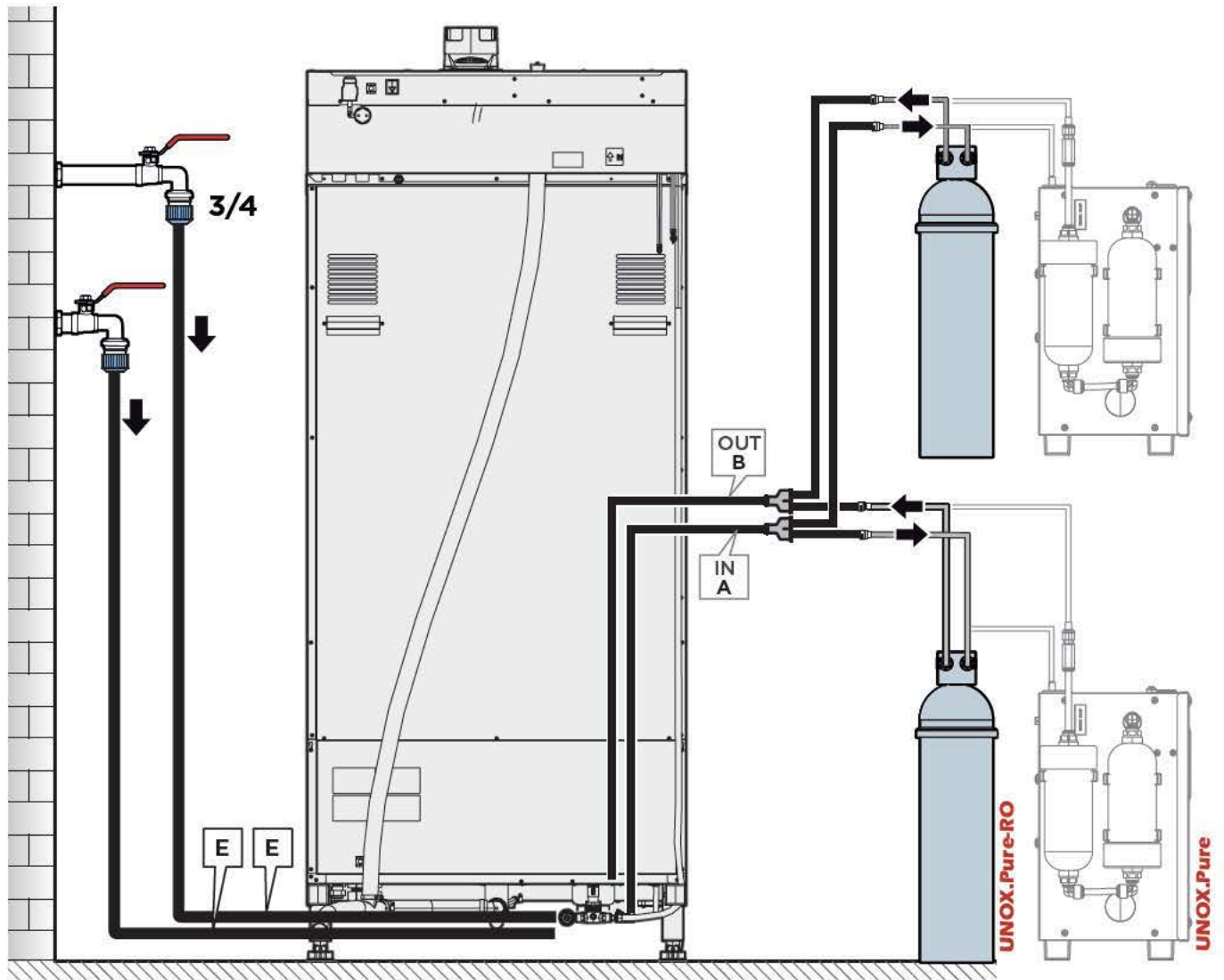

- A: Water for cavity steam
- D: Water for OVEN cleaning (PLUS and ONE models only)
- E: Incoming water
- F: Appliance drain
- G: Water for HOOD cleaning (PLUS and ONE models only)

## 10 FILLING THE DETERGENT TANK

(PLUS and ONE models only)

! Filling can only be done with the 1-litre bottles of the **UNOX.Det&Rinse Plus** detergent.

To refill the detergent:

1. Wear gloves to avoid direct contact of hands with detergent.
2. Take out the tank from under the oven until you hear a "click".
3. Open the lid of the tank.
4. Open the cap of the UNOX 1-litre detergent bottle without removing/piercing the protective film!
5. Turn the bottle upside down and screw it on the tank (by screwing the bottle, a pin in the tank breaks the protective film, which allows the detergent to come out).
6. Once the bottle is emptied, unscrew it to remove it; avoid dripping

! The detergent must not come into contact with skin, eyes or mucous membranes. In case of contact with the detergent, follow the instructions found on the safety data sheet.

7. Repeat the process up to the maximum level allowed indicated on the front of the tank. (Maximum capacity of the tank is 4 litres = 4 bottles)

8. Remove the bottle.
9. Replace the tank under the oven until it stops.
10. Dispose of the gloves, taking care not to touch the areas spoiled with detergent.

! Never touch the detergent with bare hands!

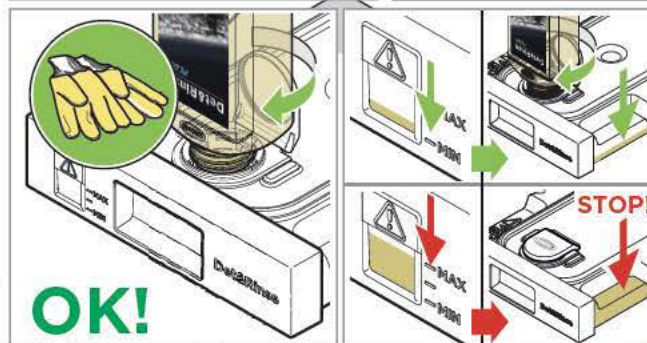
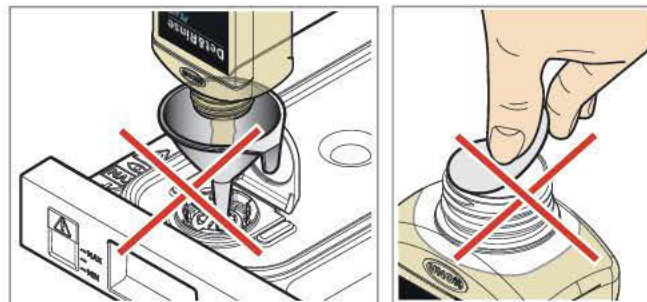

OK!

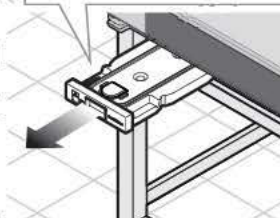

EN

## 11 EXHAUST (ONLY FOR ELECTRICAL OVENS)

Cooking produces hot exhaust fumes and odours that are evacuated through an exhaust pipe on the top of the appliance.

! Make sure that no objects or materials that may obstruct fume evacuation or become damaged by the temperature or fumes are placed above the smoke exhaust. Do not leave flammable materials near the smoke exhaust.

Outdoor evacuation of fumes can be done using:

- A cooker hood of adequate power and size for the type of oven.
- A cooker hood made by the manufacturer and directly managed by a self-diagnosis system of the oven.

Follow the instructions on the UNOX hood packaging for their assembly.

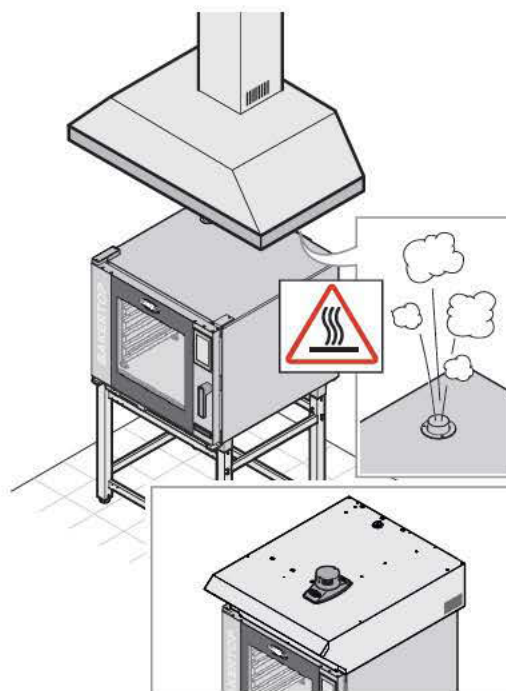



## 12 FUMES AND COMBUSTION GASSES EXHAUST (ONLY FOR GAS OVENS)

The exhaust pipes evacuate fumes and odours from the oven cavity as well as the exhaust gases. Evacuation may be done in a variety of manners: select the method best suited to the nominal power of the appliances installed; and follow the local/national installation regulations of the country of use.

- 1) Evacuation through a cooker hood of adequate power and size for the type of oven.

The hood must be installed at least 500mm from the exhaust pipe.

 Exhaust gases may heat up to 500°C. Do not use exhaust pipes made of aluminium or materials not resistant to these temperatures.

 Make sure that there are no objects or materials obstructing the flue or which may be damaged by the temperature or fumes. Do not leave flammable materials near the smoke exhausts.

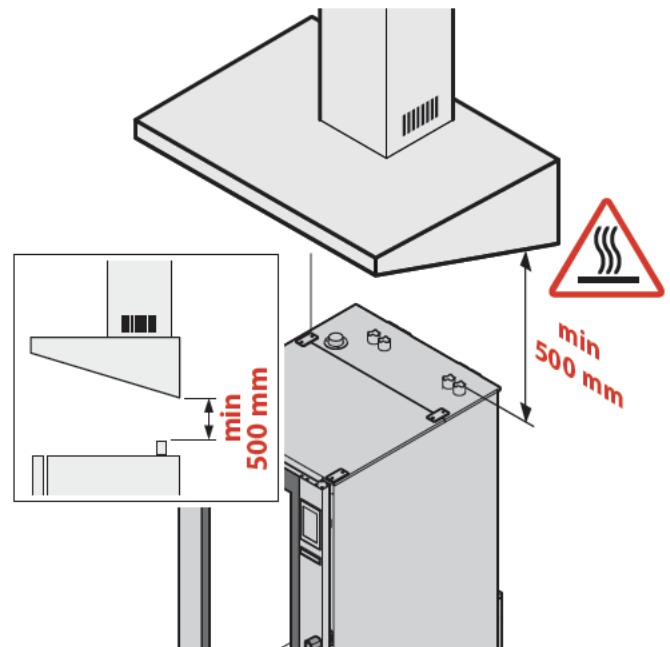

- 2) Evacuation through an efficient ventilation flue. The oven should be obligatorily equipped with a ventilation switch option provided on request by UNOX

The ventilation flue must:

- maintain the same diameter ( $\varnothing D$ ) as the oven's ventilation throughout its length;
- have an upright section ( $3\varnothing D$ ) above the ventilation elbow that is 3 times the diameter  $\varnothing D$ ;
- follow an upward trajectory at a minimum incline of 10%, and must incorporate no angles smaller than 90 degrees. The horizontal part (L) must not exceed 1.5 metres in length.

 We recommend a flue cover be installed on top of the external end of the flue, to prevent rainwater from getting into the oven and to minimise pressure drops caused by the Venturi effect, which can occur during strong air currents.

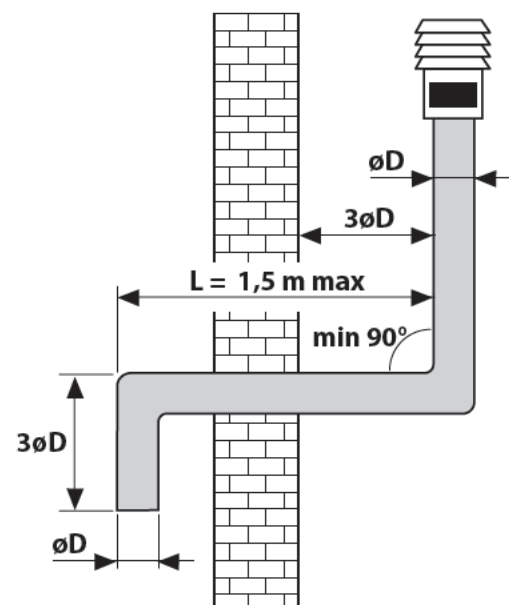

## 13 OVEN RESETTING PROCEDURE (RESERVED FOR SERVICE CALLS)

To reset the functioning of the oven, remove the black cap of the thermostat by unscrewing it and press the red pin as illustrated (operation reserved for Service calls).

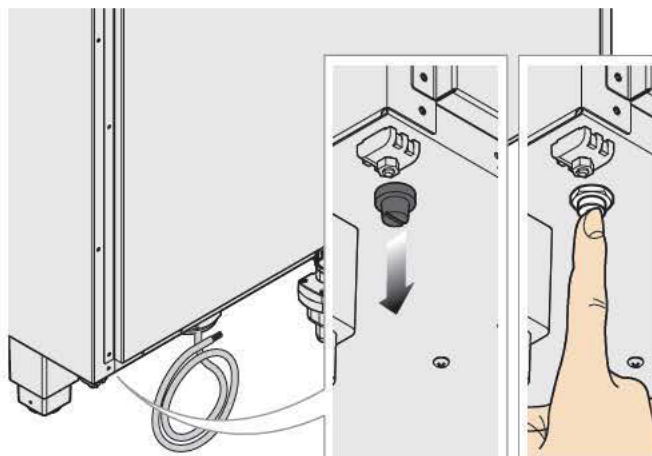

## 14 CONNECTING STACKED APPLIANCES (MAXI.LINK) (PLUS and ONE models only)

All ovens of the **CHEFTOP-BAKERTOP MIND. Maps™** line are designed to be connected to accessories (prover, hood, etc.). The accessories connect to the oven by means of ModBus connectors located on the back of the oven, which automatically connect.

- 1 Disconnect all appliance from the electricity mains.
  - 2 Remove the rear panel of the oven to access the power board.
  - 3 Connect the RJ45 cable to one of the ModBus outlets corresponding to the power board.
  - 4 Replace the rear panel of the ovens.
  - 5 Reconnect all the appliances to the electricity mains.
- + Follow the instructions contained in the accessory packing for information on how to fully install and manage them.
- ! Connect the ModBus cables only to the relative ModBus connectors and not to the RJ45 Ethernet connectors.

## 15 PLANNED MAINTENANCE SERVICE (ANNUALLY)

- Tighten all electrical connections.
- Check the polarity of the incoming 220-240Vac and earth continuity
- Check the unit is set for the correct gas pressures and gas type.
- Complete a full safety check of the gas system CO-CO2 emission according to the oven model
- Check all connection for gas leaks with an electronic gas leak detector
- Check the ionization current from the flame sensor

For the maintenance refer to your local reseller or contact directly UNOX Italy.

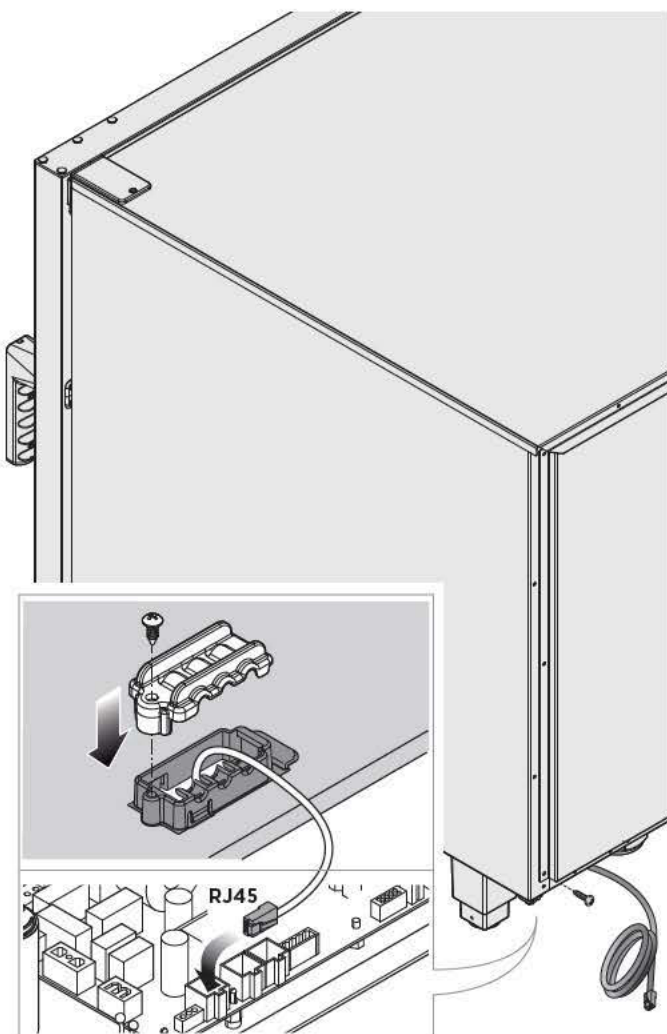

## DISPOSAL

Pursuant to article 13 of Italian Legislative Decree 49 of 2014 "Implementation of the WEEE Directive 2012/19/EU on waste electrical and electronic equipment"



The crossed-out wheeled bin symbol indicates that the product was placed on the market after 13 August 2005 and that, at the end of its useful life, it should not be disposed of with other waste, but must be collected separately.

■ All appliances are made with recyclable metal materials (stainless steel, iron, aluminium, galvanized steel, copper, etc.) in percentages above 90% by weight.

Before disposal, ensure the appliance is unusable by removing the power cable and all compartment or cavity closure devices (where present).

At the end of its useful life, the product must be disposed of in such a way as to reduce any negative impact on the environment and make efficient use of available resources. Prefer prevention, preparation for reuse, recycling and reclamation, and remember "the polluter pays". Please note that illegal or incorrect disposal of the product incurs penalties, as provided for by current legislation.

Information on disposal in Italy

In Italy, WEEE appliances must be delivered to:

- recycling centres (also known as waste disposal sites/facilities)
- the dealer from whom a new appliance is purchased, who is required to collect them free of charge ("one-for-one" exchange);

Information on disposal in European Union countries

The EU Directive on WEEE appliances has been implemented differently by each country. Therefore, if you want to dispose of this appliance, we recommend you contact your local authority or dealer for information on the correct disposal method.

## CERTIFICATION

### EU declaration of conformity for electrical and gas appliances

Manufacturer: UNOX S.p.A.

Address: Via Majorana, 22 - 35010 Cadoneghe, Padua, Italy

Declares, under its own responsibility, that the product

#### **CHEFTOP-BAKERTOP MIND.Maps™**

For electric and gas ovens:

complies with the Machinery Directive 2006/42/EC through the following standards:

EN 60335-1: 2014 + A11:2014

EN 60335-2-42: 2003 + A1: 2008 + A11:2012

EN62233: 2008

EN 60335-2-102:2006 + A1:2010

complies with the Electromagnetic Compatibility Directive 2014/30/EC through the following standards:

EN 55014-1: 2006 + A1: 2009 + A2: 2011

EN 55014-2: 1997 + A1: 2001 + A2: 2008

EN 61000-3-2: 2006 + A1: 2009 + A2: 2009

EN 61000-3-3: 2008

EN 61000-3-11: 2000

EN 61000-3-12: 2011

EN 61000-6-2: 2005

EN 61000-6-3: 2007

For gas ovens only:

complies with the (EU) GEAR Regulation 2016/426 through the following standards:

EN 203-1: 2014 / EN 203-2-2: 2006





INVENTIVE SIMPLIFICATION

## EUROPE

**IT - ITALIA**  
UNOX S.p.a

E-mail: info@unox.it  
Tel: +39 049 8657511

**GB - UNITED KINGDOM**  
UNOX UK Ltd.

E-mail: info@unoxuk.com  
Tel: +44 1252 851 522

**CZ - ČESKÁ REPUBLIKA**  
UNOX DISTRIBUTION s.r.o.

E-mail: info.cz@unox.com  
Tel: +420 241 940 000

**BG - БЪЛГАРИЯ**  
UNOX BULGARIA

E-mail: info.bg@unox.com  
Tel: +359 2 419 05 00

**NL - NETHERLANDS**  
UNOX NETHERLANDS B.V.

E-mail: info.nl@unox.com  
Tel: +31 6 27 21 14 10

**DE - DEUTSCHLAND**  
UNOX DEUTSCHLAND GMBH

E-mail: info.de@unox.com  
Tel: +49 2951 98760

**IE - IRELAND**  
UNOX IRELAND

E-mail: info.ie@unox.com  
Tel: +353 (0) 87 32 23 218

**HR - HRVATSKA**  
UNOX CROATIA

E-mail: narudzbe@unox.com  
Tel: +39 049 86 57 538

**AT - ÖSTERREICH**  
UNOX ÖSTERREICH GMBH

E-mail: info.de@unox.com  
Tel: +43 800 880 963

**PL - POLSKA**  
Unox Polska Sp. z o.o.

E-mail: info.pl@unox.com  
Tel: +48 665 232 000

**FR - FRANCE, BELGIUM  
& LUXEMBOURG**  
UNOX FRANCE s.a.s.

E-mail: info.fr@unox.com  
Tel: +33 4 78 17 35 39

**ES - ESPAÑA**  
UNOX PROFESIONAL  
ESPAÑA S.L.

E-mail: info.es@unox.com  
Tel: +34 900 82 89 43

**TR - TÜRKİYE - UNOX TURKEY**  
Profesyonel mutfak ekipmanları  
endüstri ve ticaret limited şirketi

E-mail: info.tr@unox.com  
Tel: +90 530 176 62 03

**RU - РОССИЯ, ПРИБАЛТИКА  
И СТРАНЫ СНГ**  
UNOX РОССИЯ

E-mail: info.ru@unox.com  
Tel: +7 (499) 702 - 00 - 14

**SC - SCANDINAVIAN  
COUNTRIES**  
UNOX SCANDINAVIA AB

E-mail: info.se@unox.com  
Tel: +46(0)790 75 63 64

**PT - PORTUGAL**  
UNOX PORTUGAL  
E-mail: info.pt@unox.com  
Tel: +351 918 228 787

## AMERICA

**US - U.S.A. & CANADA**  
UNOX Inc.

E-mail: info.usa@unox.com  
Tel: +1 800 489 8669

**AR - ARGENTINA**  
UNOX ARGENTINA

E-mail: info.ar@unox.com  
Tel: +54 911 37 58 43 46

**CO - COLOMBIA**  
UNOX COLOMBIA

E-mail: info.co@unox.com  
Tel: +57 350 65 88 204

**BR - UNOX BRASIL**  
SERVICOS LTDA.

E-mail: info.br@unox.com  
Tel: +55 11 98717-8201

**MX - MEXICO**  
UNOX MEXICO,  
S. DE R.L. DE C.V.

E-mail: info.mx@unox.com  
Tel: +52 55 8116-7720

## ASIA, OCEANIA & AFRICA

**ZA - SOUTH AFRICA**  
UNOX SOUTH AFRICA

E-mail: info.sa@unox.com  
Tel: +27 845 05 52 35

**PH - PHILIPPINES**  
UNOX PHILIPPINES

E-mail: info.asia@unox.com  
Tel: +63 9173108084

**AU - AUSTRALIA**  
UNOX AUSTRALIA PTY Ltd.

E-mail: info@unoxaustralia.com.au  
Tel: +61 3 9876 0805

**UZ - UZBEKISTAN**  
UNOX PRO LLC

E-mail: info.uz@unox.com  
Tel: +998 90 370 90 10

**KR - 대한민국**  
UNOX KOREA CO. Ltd.

이메일: info.asia@unox.com  
전화: +82 2 69410351

**AC - OTHER  
ASIAN COUNTRIES**  
UNOX (ASIA) SDN. BHD

E-mail: info.asia@unox.com  
Tel: +603-58797700

**TW - TAIWAN,  
HONG KONG & MACAU**  
UNOX TAIWAN

E-mail: info.tw@unox.com  
Tel: +886 928 250 536

**MY - MALAYSIA  
& SINGAPORE**  
UNOX (ASIA) SDN. BHD

E-mail: info.asia@unox.com  
Tel: +603-58797700

**CN - 中华人民共和国**  
UNOX TRADING (SHANGAI)  
Ltd. CO.

电子邮件: info.asia@unox.com  
电话: +603-58797700

**NZ - NEW ZEALAND**  
UNOX NEW ZEALAND Ltd.

E-mail: info@unox.co.nz  
Tel: +64 (0) 800 76 0803

**AE - U.A.E.**  
UNOX MIDDLE EAST DMCC

E-mail: info.uae@unox.com  
Tel: +971 4 554 2146

**ID - INDONESIA**  
UNOX INDONESIA

E-mail: info.asia@unox.com  
Tel: +62 81908852999

unox.com



L12444C3

All images used are for illustrative purposes only.

All features indicated in this catalogue may be subject to change and could be updated without notice.