



TMTEDDY is a registered trademark belonging to Varimixer A/S.



Operating Instructions And Spareparts

Valid from machine number:
5900000



Varimixer

Varimixer USA
2215 East River Road P: (800) 222-1138
Moraine, Ohio 45439 varimixerusa.com

DRN: 20005-2136
2022 01 17

Limited Mixer Warranty - 5 qt

VARIMIXER warrants to the original purchaser of new equipment that said equipment, when installed in accordance with our instructions within North America and subjected to normal use, is free from defects in material or workmanship for a period of 1 year. Wear parts, such as belts, are excluded. Hub attachments, such as shredders, slicers and grinders have a 1 year warranty that only covers parts. Warranty begins on date of factory shipment to an end user, or up to 6 months after factory shipment to a dealer or distributor. Payment by VARIMIXER for service under this warranty requires that service be authorized in advance. Contact VARIMIXER Technical Support to arrange for service.

THIS WARRANTY IS IN LIEU OF ALL OTHER WARRANTIES, WHETHER EXPRESSED OR IMPLIED. VARIMIXER EXPRESSLY DISCLAIMS ANY IMPLIED WARRANTY OF MERCHANTABILITY OR EXPRESSED OR IMPLIED WARRANTY OF FITNESS FOR A PARTICULAR PURPOSE.

VARIMIXER'S OBLIGATION AND LIABILITY UNDER THIS WARRANTY IS EXPRESSLY LIMITED TO REPAIRING AND REPLACING EQUIPMENT WHICH PROVES TO BE DEFECTIVE IN MATERIAL OR WORKMANSHIP WITHIN THE APPLICABLE WARRANTY PERIOD. All repairs pursuant to this Warranty will be performed by an Authorized Designated VARIMIXER Service Location during normal working hours. IN NO EVENT SHALL VARIMIXER BE LIABLE FOR INCIDENTAL OR CONSEQUENTIAL DAMAGES TO BUYER OR ANY THIRD PARTY, INCLUDING, WITHOUT LIMITATION, LOSS OF PROPERTY, PERSONAL INJURY, LOSS OF BUSINESS OR PROFITS OR OTHER ECONOMIC LOSSES, OR STATUTORY OR EXEMPLARY DAMAGES, WHETHER IN NEGLIGENCE, WARRANTY, STRICT LIABILITY, OR OTHERWISE.

This warranty is given only to the first purchaser from a retail dealer. No warranty is given to subsequent transferees.

This warranty does not cover product failures caused by: failure to maintain, neglect, abuse, damage due to excess water, fire, normal wear, improper set up and use. Periodic maintenance is not covered.

Example of items not covered under warranty, but not limited to just these items:

1. Acts of God, fire, water damage, vandalism, accident, theft.
2. Freight damage.
3. Improper installation or alteration of equipment.
4. Use of generic or after market parts.
5. Repairs made by anyone other than a VARIMIXER designated servicer.
6. Lubrication.
7. Expendable wear parts. (This includes the bowl, flat beater, wire whip, spiral dough hook, and the pastry knife.)
8. Cleaning of equipment.
9. Misuse or abuse.

This warranty is not in force until such time as a properly completed, digitally signed Installation/Warranty Registration has been received by VARIMIXER within 30 days from the date of installation. Register online at www.varimixerusa.com/support/warranty-registration-form.

THE FOREGOING WARRANTY PROVISIONS ARE A COMPLETE AND EXCLUSIVE STATEMENT BETWEEN THE BUYER AND SELLER. VARIMIXER NEITHER ASSUMES NOR AUTHORIZES ANY PERSONS TO ASSUME FOR IT ANY OTHER OBLIGATION OR LIABILITY IN CONNECTION WITH SAID EQUIPMENT.

WARRANTY REGISTRATION
GO TO WWW.VARIMIXERUSA.COM
TO FILL OUT AND SUBMIT YOUR WARRANTY REGISTRATION.

WWW.VARIMIXERUSA.COM/SUPPORT/WARRANTY-REGISTRATION-FORM

1 OPERATING INSTRUCTIONS TEDDY™ V5A Food Mixer

CONTENTS:

SAFETY:	1
INSTALLATION OF NEW MIXER:	1
CONNECTION TO POWER:	2
INTRODUCTION TO THE MIXER:	2
RECOMMENDED WORKING SPEEDS:	2
OPERATION OF THE MIXER:	3
MAXIMUM CAPACITY OF THE MIXER:	3
OVERLOAD:	3
CLEANING AND HYGIENE:	3
MAINTENANCE:	4
LIST OF ERRORS AND POSSIBLE SOLUTIONS:	4
ACCESSORIES	4
SPARE PARTS	5

SAFETY:

The machine is a technical tool, and is intended solely for working purposes.

The constant noise level of the workplace of the operator is lower than 70 dB (A).

- The mixer will only start when the upper part is lowered.
- The upper part can only be tilted up when the mixer is stopped.
- Protection from excess current, excess voltage and too low voltage.
- The mixer is provided with fixed bowl screen.
- The mixer is equipped with a safety-timeout that turns off the mixer after 45 minutes continuous operation.

INSTALLATION OF NEW MIXER:

The following equipment is included:

- | | | |
|--------------------|--------|--------------------|
| ✓ Cable | ✓ Hook | ✓ Bowl |
| ✓ Beater | ✓ Whip | ✓ Lid for the bowl |
| ✓ Ingredient chute | | |

Before taking the mixer into use, check that all parts are delivered.

Dimensions and weight:

TEDDY inclusive equipment:

- Net weight with equipment: 44 Lbs.
- Outside dimensions of mixer: 18 1/4 " x 9 1/2 " x 15 3/4 "

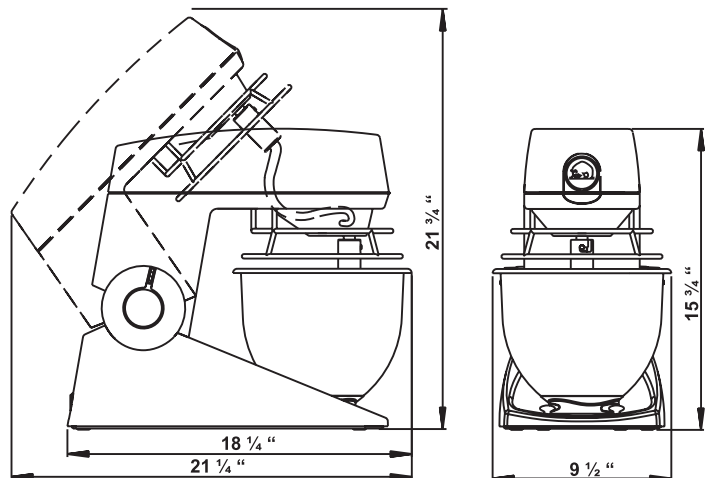

Location:

The mixer is to be placed on a stable and horizontal table.

The machine must be monitored while it is in operation.

The mixer is designed for manufacture of products which do not during processing cause reactions or emit substances which may be detrimental to the user.

Putting your fingers in the bowl while the mixer is running may cause injuries.

The mixer is listed by:



CONNECTION TO POWER:



The enclosed cable must be used.

The mixer must be connected to ground!

- Only single phase power supply with ground must be used for the mixer. Use the enclosed cable.
- A plug with 2 pins + ground must be used.
- Check that the voltage of the power supply corresponds the voltage printed on the rating plate placed in the bottom of the mixer and stated on the packing.
- The mixer must be protected by a differential circuit breaker and a fuse of max. 10 A.
A fuse is built into the cable plug.

The power characteristics of the mixer:

Supply voltage (V)	Output (W)	Frequency (Hz)	Voltage (A)	Motor Power (hp)
115	300	50/60	3.4	0.4

INTRODUCTION TO THE MIXER:

TEDDY is a small professional mixer for kneading, mixing and whipping in all environments where professional equipment is required.

Any operation of the mixer is made by means of the rotary knobs on the sides of the mixer. The two knobs can be used simultaneously or individually and are used both for speed regulation and as opening/closing function.

ACCESSORIES:

As standard the mixer comes with the following accessories:

- Bowl in stainless steel.
- Snap-in splash guard.
- Ingredient chute.
- Dough hook in stainless steel for kneading of dough.
- Beater in stainless steel for mixing.
- Whip in stainless steel for whipping.

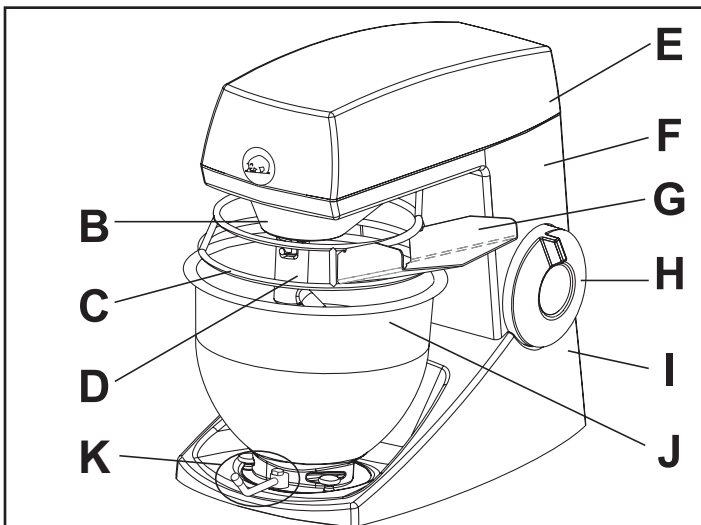
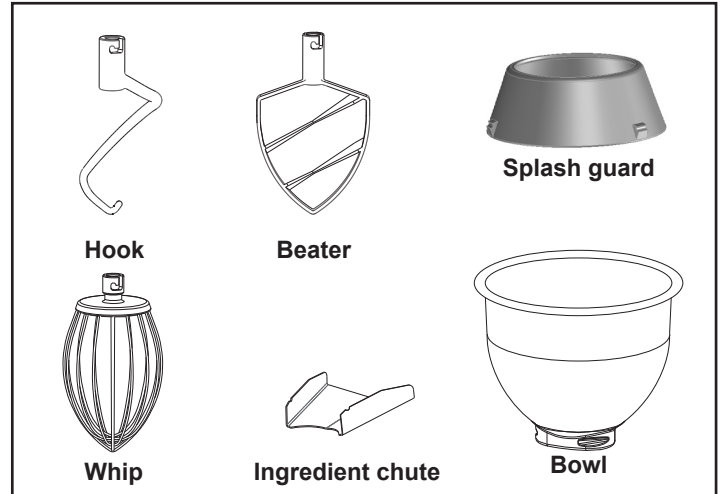

Fig. 1 The construction of the mixer

B	Housing of the planetary gear
C	Bowl screen in stainless steel
D	Bayonet shaft
E	Lid
F	Upper part
G	Ingredient chute
H	Rotary knobs (two pcs.)
I	Base
J	Bowl in stainless steel, contents 5 quarts
K	Locking arm

RECOMMENDED WORKING SPEEDS:

- Position 1-2: Low speed Kneading
- Position 1-3: Medium speed Mixing
- Position 1-5: High speed Whipping

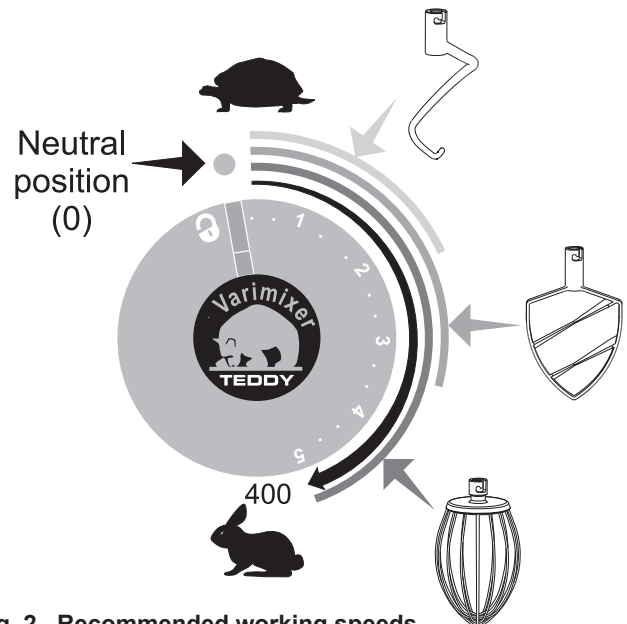

Fig. 2 Recommended working speeds

OPERATION OF THE MIXER:



The bowl must be mounted when the mixer is started!

The machine must be monitored while it is in operation

A. Turn the rotary knobs to the locking symbol (fig. 3A).



A: Locking symbol B: Neutral position C: Speeds

Fig.3 The three positions of the rotary knobs.

B. Tilt backwards the upper part of the mixer.

C. Place a tool in the bayonet shaft and turn it counter-clockwise to lock it in position (fig. 4).

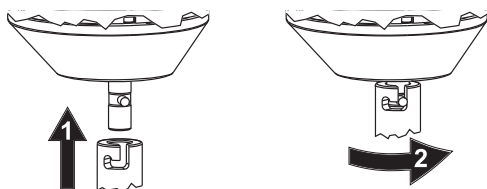
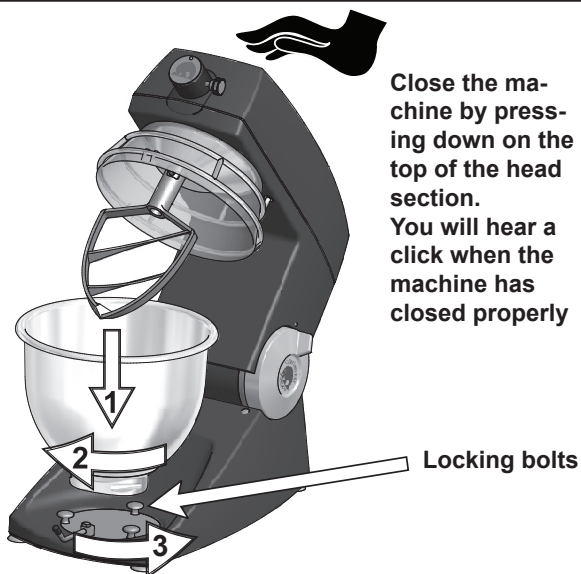

Fig. 4 Mounting of tool in the bayonet shaft.

D. Place the bowl in the mixer (1), turn it to be fixed in the locking bolts (2) and turn the handle (3) (fig. 5).



Close the machine by pressing down on the top of the head section. You will hear a click when the machine has closed properly

Locking bolts

Fig. 5 Place the bowl in the machine and twist it onto the locking bolts and turn the locking arm anticlockwise.

E. Fill the ingredients in the bowl.

F. Tilt the upper part of the mixer, including tool, down.

G. Start the mixer by turning the rotary knobs away from the locking symbol and past 1. To avoid splashing and dust from flour, it is recommended to increase the speed gradually until the required speed is obtained (fig. 3C), (see fig. 2 for recommended working speeds).

H. Stop the mixer by turning the rotary knobs back to neutral position (fig. 3B).

I. The upper part of the mixer can only be tilted backwards when the rotary knobs is turned to the locking symbol (fig. 3A).

MAXIMUM CAPACITY OF THE MIXER:

The working capacity of the mixer depends of:

- The tool used.
- Sort and quantity of the raw materials.
- The optimum speed for a good result.



Too big quantities will always reduce the quality of the product and the life of the mixer. Overloading can also result in sudden stops.

Product	Raw material	Approx. max. quantity
Bread dough, 60%	Lbs	5
Mashed potatoes	Lbs	4
Whipped cream	Qt	1
Layer cake	Lbs	6
Cake donuts	Lbs	6

OVERLOADING:

If the mixer is moving e.g. kneading dough, this is **not** due to errors or overloading.

In case of overloading the electronic variator will reduce the current to the motor and stop it.



In case of stop due to overloading, turn the rotary button back to neutral position, and the mixer can be started again.

If the motor stops after long time of operation, and cannot be started immediately after, the temperature sensor of the motor has switched off the current, and the mixer needs to cool down before it can be re-started. This protects the motor from overheating.

The mixer contains two thermal cut-outs, which automatically reconnect in case of previous disconnection by the temperature sensor.

CLEANING AND HYGIENE:

After use:

- Remove bowl and tools.
- Wash the bowl and the tools in hot water and detergent / degreaser / disinfectant. Rinse with pure water and dry.



Do not spray water on the mixer

Tools and bowl can be cleaned in dishwasher.

- Wipe the housing of the planetary gear, the bayonet shaft and the bowl screen. Use a damp sponge and a detergent / disinfectant. Rinse the parts with sponge and pure water.
- Check that the various parts have been cleaned thoroughly.
- Do not use abrasive detergents, which could scratch the surface.
- Use detergents suited for use on aluminium and plastic (polycarbonate).

MAINTENANCE:

The mixer requires no maintenance (motor and bearings for the mechanical parts are greased for life).

Safety device:

Check the function of the safety device regularly:

- The motor must stop when the rotary knobs is in neutral position (see fig. 3B).



If the safety device does not function, do not use the mixer. Contact your dealer.

LIST OF ERRORS AND POSSIBLE SOLUTIONS:



If the problem cannot be solved, contact your dealer.

The mixer does not start:

Check that ...

- The upper part of the mixer is in its down position.
- The mixer is plugged in and connected to power.
- The electrical power supply is correct.
- The fuse in the cable plug (fig.6, 1) has not been burned. If the fuse is defective, it can be replaced by the extra fuse (fig.6, 2) that is also available in the cable plug.

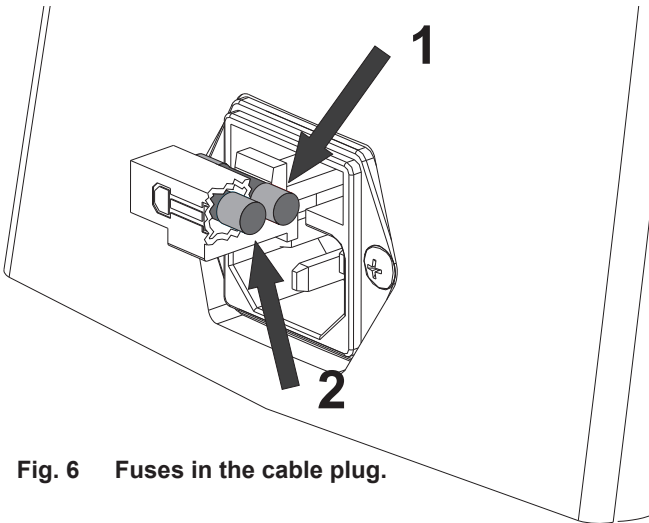

Fig. 6 Fuses in the cable plug.

The mixer stops during work:

- The mixer is overloaded due to too high speed or too heavy loading. See the paragraph “Overloading”.



In case of power failure set the rotary button back to neutral position, and the mixer can be started again.

The tool is stuck in the bayonet shaft:

This is normally due to insufficient cleaning or damaged hole in the tool:

- When the tool is stuck, do not force it free. Apply a little oil and let this work a couple of minutes.
- Turn the tool backwards and forwards until it can be removed.

Abnormal noise:

Metallic noise ...

- The tool is distorted and hits the bowl.
- The bowl has been damaged or is not in its proper position.

ACCESSORIES

Stainless steel dough hook	VHOOK-05
Stainless steel wire whip	VWHIP-05
Stainless steel flat beater	VBEAT-05SS
Plastic bowl lid	VBLID-05
Stainless steel bowl	VBOWL-05
Ingredient chute	VCHUTE-05
Splash guard	VRING-05



5 Spare parts

No.	Description	Part No.
# 1	Control Button, Left and Right	AR005-178-TZ001
# 2	Base	AR005-022-TZ0xx
2.1	Fuse 5 A, slow, 120V	AR005-418-00001
2.2		
3	Cover Plate	AR005-347-TZ001
4	Cable with Rheostat and Microswitches	AR005-193-TZ002
# 5	Tilt Bearing, Left and Right	AR005-337-TZ001
# 6	Lid	AR005-024-TZ0xx
7	Intermediate shaft	AR005-325-TZ001
# 8	Upper Part	AR005-023-TZ0xx
9	Lock Pin	AR005-332-TZ001
10	Planetary Head	AR005-002-TS001
11	Control Board	AR005-378-TS003
12	Cable	AR005-193-TS004
13	Motor	AR005-339-TZ001
13.1	Poly-V Belt	AR005-090-TD001
13.2	Poly Belt	AR005-090-TD001
14	Release Housing	AR005-372-TS001
15	Weight Compensator	AR005-352-TZ001
17	Machine Feet	AR005-213-TZ001
18	Fixing of Bowl	AR005-340-TZ001
19	Bowl Lock	AR005-336-TS010
20	Power Cable	AR005-194-TD006

Please state the color when ordering





Varimixer

Varimixer USA
2215 East River Road
Moraine, Ohio 45439
P: (800) 222-1138
varimixerusa.com