

# V

## Operating Instructions



Valid from machine number:

**V80 : 80002012**

**V100 :100002125**

**V80**  
**V80PL**  
**V100PL**



# Varimixer

Varimixer USA  
2215 East River Road P: (800) 222-1138  
Moraine, Ohio 45439 varimixerusa.com

EN

DRN: 20080-1536  
2022 10 31

## Limited Mixer Warranty - 10 qt to 150 qt

VARIMIXER warrants to the original purchaser of new equipment that said equipment, when installed in accordance with our instructions within North America and subjected to normal use, is free from defects in material or workmanship for a period of 4 years. Wear parts, such as belts, are excluded. Hub attachments, such as shredders, slicers and grinders have a 1 year warranty that only covers parts. Warranty begins on date of factory shipment to an end user, or up to 6 months after factory shipment to a dealer or distributor. Payment by VARIMIXER for service under this warranty requires that service be authorized in advance. Contact VARIMIXER Technical Support to arrange for service.

THIS WARRANTY IS IN LIEU OF ALL OTHER WARRANTIES, WHETHER EXPRESSED OR IMPLIED. VARIMIXER EXPRESSLY DISCLAIMS ANY IMPLIED WARRANTY OF MERCHANTABILITY OR EXPRESSED OR IMPLIED WARRANTY OF FITNESS FOR A PARTICULAR PURPOSE.

VARIMIXER'S OBLIGATION AND LIABILITY UNDER THIS WARRANTY IS EXPRESSLY LIMITED TO REPAIRING AND REPLACING EQUIPMENT WHICH PROVES TO BE DEFECTIVE IN MATERIAL OR WORKMANSHIP WITHIN THE APPLICABLE WARRANTY PERIOD. All repairs pursuant to this Warranty will be performed by an Authorized Designated VARIMIXER Service Location during normal working hours. IN NO EVENT SHALL VARIMIXER BE LIABLE FOR INCIDENTAL OR CONSEQUENTIAL DAMAGES TO BUYER OR ANY THIRD PARTY, INCLUDING, WITHOUT LIMITATION, LOSS OF PROPERTY, PERSONAL INJURY, LOSS OF BUSINESS OR PROFITS OR OTHER ECONOMIC LOSSES, OR STATUTORY OR EXEMPLARY DAMAGES, WHETHER IN NEGLIGENCE, WARRANTY, STRICT LIABILITY, OR OTHERWISE.

This warranty is given only to the first purchaser from a retail dealer. No warranty is given to subsequent transferees.

This warranty does not cover product failures caused by: failure to maintain, neglect, abuse, damage due to excess water, fire, normal wear, improper set up and use. Periodic maintenance is not covered.

Example of items not covered under warranty, but not limited to just these items:

1. Acts of God, fire, water damage, vandalism, accident, theft.
2. Freight damage.
3. Improper installation or alteration of equipment.
4. Use of generic or after market parts.
5. Repairs made by anyone other than a VARIMIXER designated servicer.
6. Lubrication.
7. Expendable wear parts. (This includes the bowl, flat beater, wire whip, spiral dough hook, and the pastry knife.)
8. Cleaning of equipment.
9. Misuse or abuse.

This warranty is not in force until such time as a properly completed, digitally signed Installation/Warranty Registration has been received by VARIMIXER within 30 days from the date of installation. Register online at [www.varimixerusa.com/support/warranty-registration-form](http://www.varimixerusa.com/support/warranty-registration-form).

THE FOREGOING WARRANTY PROVISIONS ARE A COMPLETE AND EXCLUSIVE STATEMENT BETWEEN THE BUYER AND SELLER. VARIMIXER NEITHER ASSUMES NOR AUTHORIZES ANY PERSONS TO ASSUME FOR IT ANY OTHER OBLIGATION OR LIABILITY IN CONNECTION WITH SAID EQUIPMENT.

WARRANTY REGISTRATION  
GO TO VARIMIXERUSA.COM  
TO FILL OUT AND SUBMIT YOUR WARRANTY REGISTRATION.  
[VARIMIXERUSA.COM/SUPPORT/WARRANTY-REGISTRATION-FORM](http://VARIMIXERUSA.COM/SUPPORT/WARRANTY-REGISTRATION-FORM)

## **Caution -READ BEFORE OPERATING- Caution**

Always observe local laws and regulations, paying particular attention to the operator's age, physical and mental condition.

This manual should be seen as an integral part of the mixer and should be kept by the machine throughout its working life.

Before the machine is commissioned, it is important to read these instructions thoroughly.

The manufacturer may update the product manual without updating this copy of the manual.

- Varimixer recommends all operators must be at least 18 years of age.
- All operators must be thoroughly trained before being allowed to operate the mixer.
- NEVER reach into the bowl when the mixer is running.
- Do not wear loose clothing or rings while operating the mixer.
- Stop the mixer and lower the bowl before adding ingredients, scraping the bowl, removing the agitator, or removing the product.
- Stop the mixer before removing or installing attachments into the drive hub.
- Do not attempt to assemble or disassemble attachments while mounted into the drive hub.
- Always use the pusher plate with the slicer/meat grinder attachments.
- NEVER bypass the safety mechanisms supplied on the mixer. Doing so can cause injury and is the responsibility of the user to ensure these safety mechanisms are operating properly.

## **CONTENTS:**

General.....	2
Unpacking.....	2
Safety .....	3
Installation of the Mixer.....	3
Cleaning .....	4
Ingredient chute.....	4
The maximum capacity of the Mixer.....	5
Recommended maximum speeds .....	5
Operating the mixer .....	6
Operating the frontpanel.....	7
Construction of the Mixer.....	8
Maintenance and lubrication.....	8
Adjustment of special V-belt .....	9
Adjustment of speed.....	9
Adjustments of speed (low and high speed cam disks).....	10
Adjustment of bowl fixing.....	12
Adjustment of bowl centering .....	12
Adjustment of bowl height .....	13
List of errors and possible solutions .....	14
Error codes .....	14
Manual reset of motor protection relay .....	15
Principle electrical diagram.....	16
Cleaning guide.....	20
Contents of the Declaration of conformity for machinery.....	22

## **UNPACKING:**

The machine should be unpacked and the packaging disposed of according to regulations applicable in the country concerned.

Before the machine is removed from the pallet, check that all parts are present with the machine:

- Safety guard, Ingredient chute, Bowl.
- Grease gun, Rubber feet and Spacers for height adjustment.
- Bowl trolley, whip, beater, hook, scraper with blade and attachment drive, if these were selected with the order.

The machine is mounted onto the pallet with four bolts, to release the machine from the pallet, unscrew the 4 nuts with the supplied tool and hammer out the bolts.



## **SAFETY:**

The mixer is designed for commercial use in kitchens, catering outlets and bakeries.

The mixer must not be used in an explosive atmosphere.

The mixer may only be used as specified in this manual.



The mixer is designed for manufacture of products which do not during processing cause reactions or emit substances which may be detrimental to the user.



Putting your fingers in the bowl while the mixer is running may cause injuries.

Electrical connection must only be carried out by a certified electrician.

Lifting equipment should always be used to move the mixer.



When the mixer is moved, it should be in an upright position at all times.

The mixer must not be pulled or lifted by the bowl lift handle (V80 only) and speed selection handle.

Powdery ingredients:

Do not pour powdery ingredients into the bowl from a great height.



Bags of e.g. flour should be opened at the bottom, down into the bowl.

Do not increase to maximum speed too quickly.



**Warning for users with implants (e.g. pacemakers, defibrillators etc.) Mixer and safety guard are equipped with strong magnets.**

Area with magnets  
Safety guard.

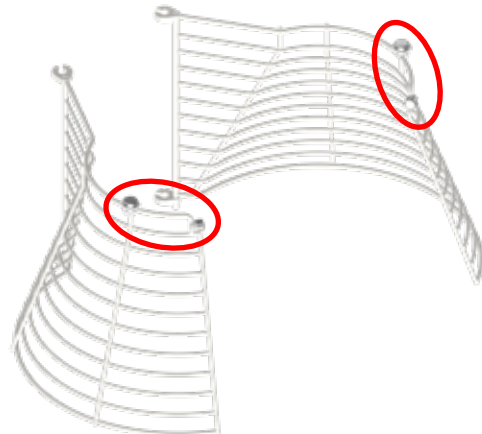

## **INSTALLATION OF THE MIXER:**

Install the machine so there is workspace for normal use and maintenance.

The floor of the workspace where the machine is installed must be firm, even and level.

The mixer must be mounted with the supplied feet, that eliminate both shaking and rusting. If the floor is not completely even, the supplied spacers are inserted under the mixer's feet to ensure the machine is level.

Foundation bolts in the floor are only necessary under special conditions, e.g. on ships.

The ambient temperature around the machine must not exceed 45°C

### **Connection to power:**

The mixer is to be connected to power via a plug. The plug must be dimensioned for min. 16 A, 208/480V~, IP44



When connecting;

3 phases + earth, use a 4 pole plug.

Before the mixer is connected to power, it should be checked that the voltage and frequency printed on the machine label is correct in relation to the place of installation. The machine label is located on the top right side of the mixer.

### **COMMISSIONING:**

Machine, bowl, tools safety guard and ingredient chute must be cleaned thoroughly before use – see section Cleaning, page 4.

Area with magnets  
Safety guard.

Area with magnets  
Bowl detection.

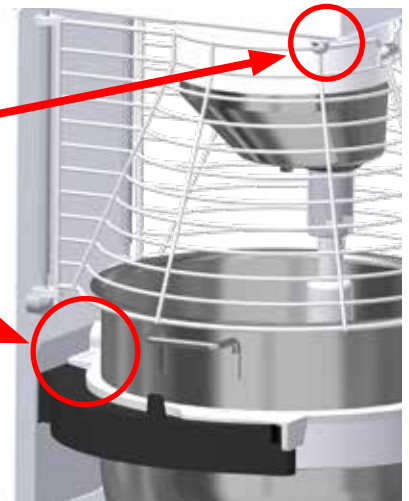

## **CHECKING THE DIRECTION OF ROTATION OF THE PLANETARY HEAD:**



Remove tool if mounted, lift up the bowl arms with the bowl to normal working position and start the mixer. Check the direction of rotation of the planetary head: the planetary head must rotate in the direction as stated by the arrow above the planetary head. If the direction of rotation is wrong, 2 of the phase wires of the connecting cable must be inverted.



## **MACHINE NET WEIGHT:**

V80	340 kg
V100	395 kg

## **CLEANING:**



Before any cleaning, disconnect the power supply to the machine by disconnecting the connection cable from the connection point

The machine should never be rinsed with a hose.

To assist in the preparation of customer-specific cleaning plans, Varimixer A/S has, based on current legislation, prepared detailed cleaning instructions, included at the end of this manual and the latest version can be found at [varimixer.com](http://varimixer.com)

## **REMOVING SAFETY GUARDS**



## **INGREDIENT CHUTE:**



When ingredients are to be added while the machine is working, use the supplied ingredient chute made of stainless steel.



## THE MAXIMUM CAPACITY OF THE MIXER:

Capacities per mix	Tool		V80	V100
Egg whites	Whip	qt	4	5
Whipped cream	Whip	qt	17	26
Buttercream frosting	Whip *)	lb	71	99
Mashed potatoes	Beater *)	lb	95	119
Cakes (US Pound cake)	Beater	lb	88	121
Icing, Fondant	Beater *)	lb	71	88
Cookies, sugar	Beater	lb	97	121
Meatball mix/vegan meatball mix	Beater *)	lb	106	132
Pasta, noodles (50%AR)	Hook **)	lb	71	99
Dough, wheat 40%AR	Hook **)	lb	77	88
Dough, wheat 50%AR	Hook	lb	88	110
Dough, wheat 55%AR	Hook	lb	104	128
Dough, wheat 60%AR	Hook	lb	117	143
Dough, whole wheat 70%AR	Hook	lb	106	143

\* Scraper recommended

\*\* Low speed only

Local variations in the characteristics of the ingredients can influence water absorption, volume and baking characteristics, etc.

### AR = Absorption Ratio

(Liquid in % of solids)

#### Calculation AR

1 lb of solids and 0,6 qt of liquid:

$$AR = \frac{0,6 \times 100}{1} = 60\%$$

#### Calculation Solids and Liquid

143 lb Dough, 60% AR

(table, max. capacity for mixer V100)

$$Solid = \frac{Max. capacity \times 100}{AR + 100}$$

$$= \frac{143 lb \times 100}{60 + 100} = 89.4 lb$$

$$Liquid = 143 lb - 89.4 lb = 53.6 lb$$

## RECOMMENDED MAXIMUM SPEEDS:

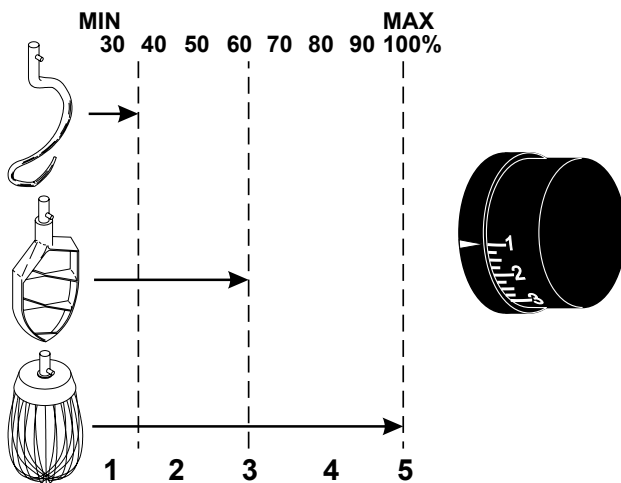

### Overload:



Do not exceed machine capacity - see table above.

Do not use too high speed, see recommended maximum speeds to the left.

Use correct tools.

Large lumps of fat or cooled ingredients must be cut into smaller parts before they are placed in the bowl.



Overload over a longer period of time will interrupt the mixer. **OL** will be shown on the mixer's display. Please see section "Error codes shown on the display" on page 14.

### Recommended applications for tools:

Whip	Beater	Hook
Cream, Egg whites, Mayonnaise, and the like	Cake dough, Butter cream, Waffle dough, Minced meat, and the like	Bread dough, Dark bread, and the like

### Correct use of tools:



For production of mashed potatoes the special wing whip or the whip with thicker wires should be used, alternatively use the beater and the whip.

Whips should not be struck against hard objects as e.g. the edge of the bowl. This will make the life of the tool shorter due to increasing deformity.

## OPERATING THE MIXER:

Fig. 1 Operation

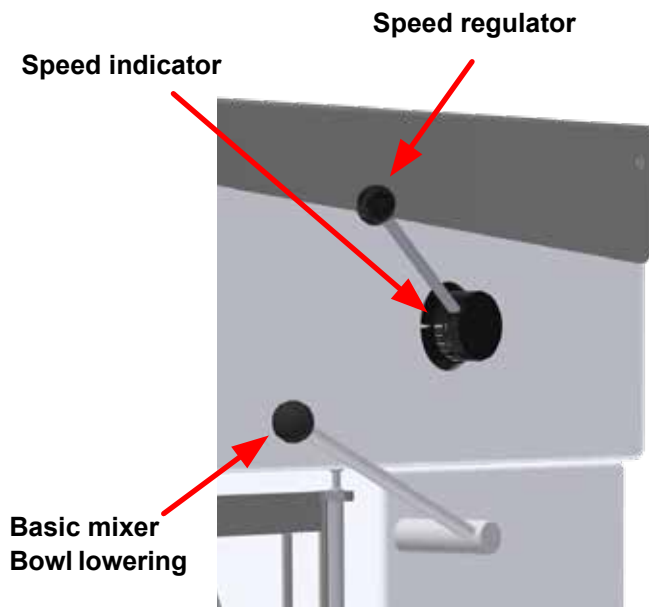

Fig. 3 Mixer with open safety guard, lowered bowl and mounted tool.



## ATTACHMENT DRIVE (V80 ONLY:)



For machines with outlets for mounting a meat mincer or vegetable cutter, the following must be observed:

Only use accessories intended for the machine, Varimixer original accessories are a guarantee for optimal operation and security.

Always read and follow the operation instructions for the tool.

Adjust the machine to the lowest speed.

When placing / removing tools, disconnect the power cable from the point of connection.

Before start:

If present remove mixing tools from the machine.

The empty bowl is put in working position.

Close the safety guard.

## OPERATING THE FRONTPANEL:

**Power OFF the mixer - Push the emergency stop.**  
**Power ON the mixer - Turn the emergency stop clockwise.**

### Timer [mmss]

Reset the timer by pressing the two timer buttons at the same time. Time is shown in minutes and seconds.

Time down

Time up

### Emergency stop

Only to be used for emergency situations and for powering off the mixer.



(Power lift) Bowl down

(Power lift) Bowl up

Start/Stop -  
(Basic mixer - Pause)

### Pause function

To be used when checking the contents of the bowl or otherwise pausing the mixer.

(Power lift) Pause

### Before starting the mixer:

Ingredients can be filled in the bowl at any time before the mixer is started.

1. Place the tool into the bowl.
2. Place the bowl in the bowl arms.
3. Grab the tool and lock it into the bayonet fitting.
4. Lift the bowl to working position.
5. Close the safety guard, (Fig. 3).

If desired, set an operating time.

The mixer is now ready to be started.

### Start the mixer:

Press  to start the mixer.

Set the speed.



Turn the speed selector lever (Fig. 1) to the rear until the required speed has been obtained,





**Before the mixer is stopped, turn the speed selector lever back to the lowest speed.**

### Stop the mixer without resetting the timer (Pause)

If it is needed to add ingredients or check the content of the bowl, the mixer can be stopped without resetting the timer.

- (Basic mixer) Press  and the mixer stops.
- (Power lift) Press  the mixer stops.

The safety guard can now be opened and the bowl can be lowered.



To start the mixer again, close the safety guard lift the bowl. The mixer can now be started by pressing (Basic mixer)  / (Power lift)  and the timer will continue counting down.

### Reset the timer:

Reset the timer by pressing the two timer buttons at the same time.

### Automatic lowering of the bowl (Power lift):

If the timer is in use, the bowl can automatically be lowered when the time runs out and the mixer stops.

While the mixer is running, double click . The green LED by  will flash until the mixer stops.

When automatic lowering of the bowl is selected it is important that you use  to stop and start the mixer, otherwise the selection will be reset.



The emergency stop should only be used in emergency situations and for powering off the mixer. Do not use the emergency stop in normal operation.

If the emergency stop is activated or main power to the mixer is cut off, the tool stops rotating and the timer is reset to zero.

### Timer automatically repeats the previous setting:

When the set time runs out, the tool stops rotating, the timer shortly display [0000] and will then display the previous selected running time.

### More about the timer:

Timer settings of up to 90 minutes.

If no running time is selected, the display will show the time elapsed since the mixer was started.

## CONSTRUCTION OF THE MIXER:

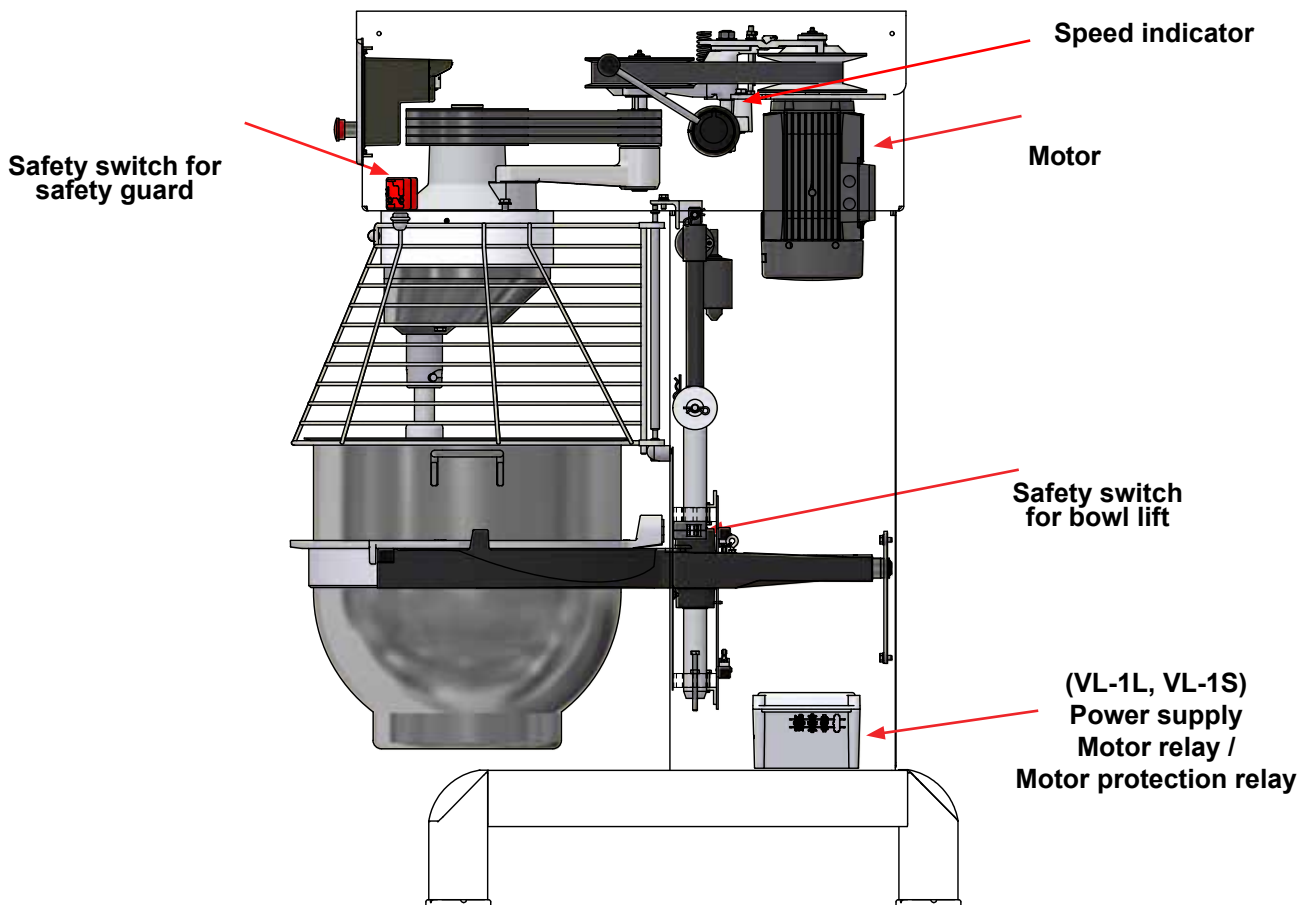

**Prior to repair or adjustment, switch off the mixer by disconnecting the power cable.**

## MAINTENANCE AND LUBRICATION:

The infinitely variable gear must be lubricated regularly, i.e. a lubrication interval of approx. **60 hours** of operation.

### **Fig 4, Lubrication of infinitely variable gear and other movable parts:**

**OBS.** Special grease!! (Use the grease gun delivered with the mixer). Start the mixer and increase the speed to approx. 50%. Stop the mixer (use the emergency stop) and open the lid on the top of the mixer. On the top of each of the two pulley set shafts is a grease nipple (**Fig. 4 point 1**). Press grease through the grease nipples until the grease gun feels hard to press or until grease comes out between the shaft and the pulleys.



**The mixer must not be started until the top lid is on and the screws have been tightened.**

Start the mixer, and set the speed back to low speed.

Stop the mixer and fill the grease gun with new grease so that it is ready for next time lubrication is needed.

### **Lubrication of other movable parts:**

The movable parts of the bowl arms, the shaft and the lifting rod must also be lubricated with oil. Remove the back cover of the mixer and lubricate the marked points with an oil can. (**Fig.4 point 2**)

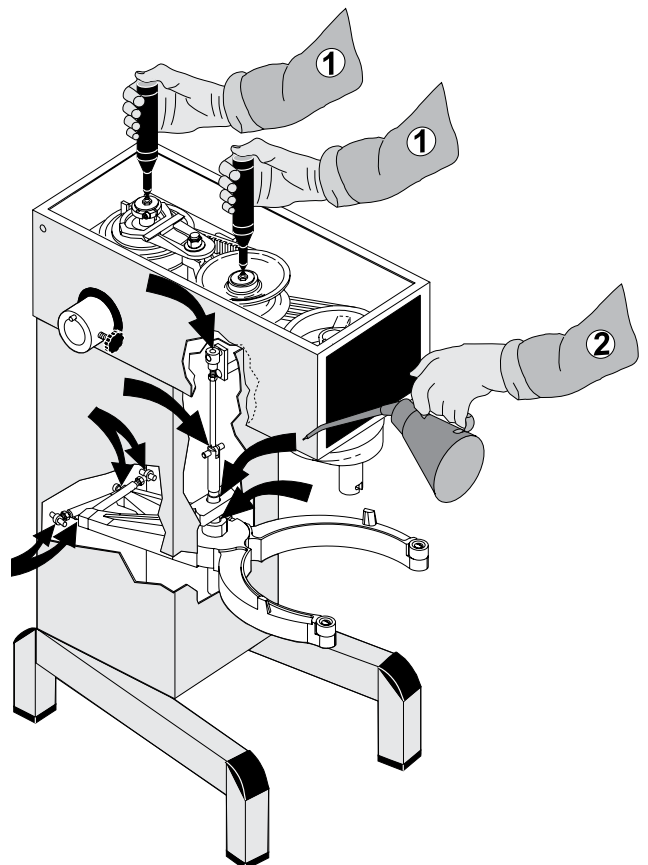

## Grease types:

Grease for the pulley set shafts: **TOTAL MULTIS XHV 2.**

Repair of the planetary head: Grease the toothed wheel and the toothed rim, only with **CASTROL Molub- Alloy OG 936 SF Heavy.**

Repair of the attachment drive: Fill the attachment drive with 0.35 L **TOTAL CERAN CA.**

## ADJUSTMENT OF SPECIAL V-BELT:

The distance (X) is only indicative as it depends on the tolerance of the special V-belt.

1. Start by tightening the V-belts (\*).
2. Tighten the special V-belt (A) by moving one or two washers from (V) to (T).
3. Start the mixer and leave it running while the nut (U) is tightened. Do not tighten it too much.
4. On the front pulley set the stud (E) on the varispeed collar (F) must be placed inside the lower fork (G) and on the rear pulley set outside the fork for belt tightener (B), (both must point backwards).
5. Tolerances in the transmission might cause the special V-belt (A) to hit the pins of the pulley sets when the speed has been adjusted. In such cases the distance (X) must be reduced.
6. Then follow the section: "Adjustment of speed"

## ADJUSTMENT OF SPEED:

1. The stop screws (J) on the speed lever should be adjusted so that the measurement (H) is 1-2 mm on the front and the rear pulley, at low and high speed, respectively. Tighten the counter nuts (K) when the speed is correctly adjusted.
2. Tolerances in the transmission might cause the special V-belt (A) to hit the pins of the pulley sets (Z) when the speed has been adjusted. In such cases the distance (X) must be reduced, see "Adjustment of special v-belt", and the speed must be readjusted.

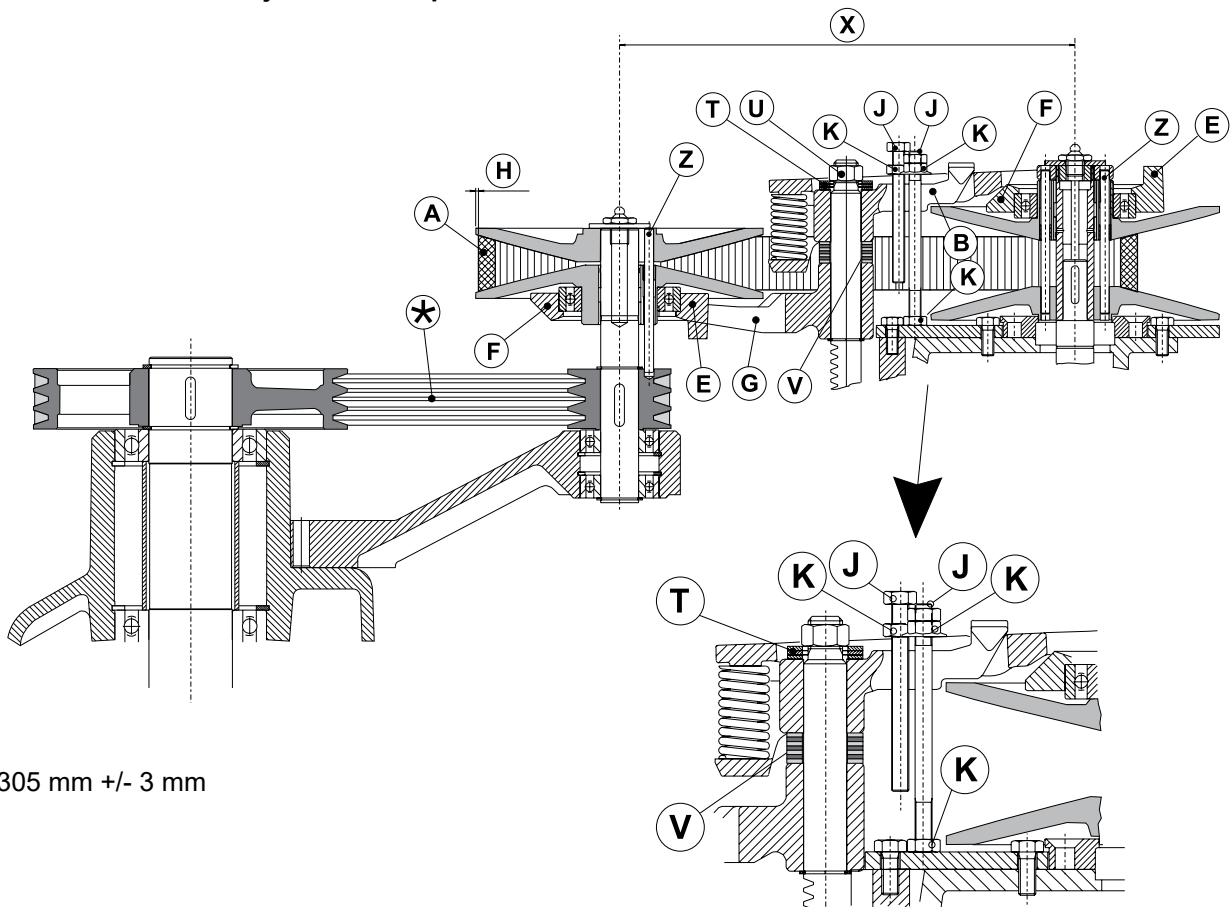

(X) = 305 mm +/- 3 mm

## **ADJUSTMENT OF BOWL CENTERING:**

First find the present bowl centering: mount the beater and the bowl, then raise the bowl arms up to normal working position. With your hand turn the beater, and then measure the distance between beater and bowl edge. By removing the rear covering, the bowl arm guide plate is now accessible (E). Loosen the screws (D) (**Fig. 6b**) and move the bowl arm guide plate in the required direction. Again turn the beater and measure the distance between beater and bowl. When the bowl has been centred, fasten the bowl arm guide plate in the new position and screw on the rear covering.

## **ADJUSTMENT OF BOWL FIXING:**

The bowl arms must be raised to normal working position. The adjusting diameter (Y) shall be measured inside between the bowl arms (**Fig. 6a**):

Adjusting diameter (Y) :	V80	=	516 mm
	V100	=	554mm

In case the bowl fastening is too loose, remove the lock ring (B) and draw the bearing (A) from the shaft (C). The bearing should be turned 180° and be mounted on the shaft again. It might be necessary to turn both bearings. At last check the bowl centering and if necessary, adjust.

**Fig. 6a** Adjusting diameter

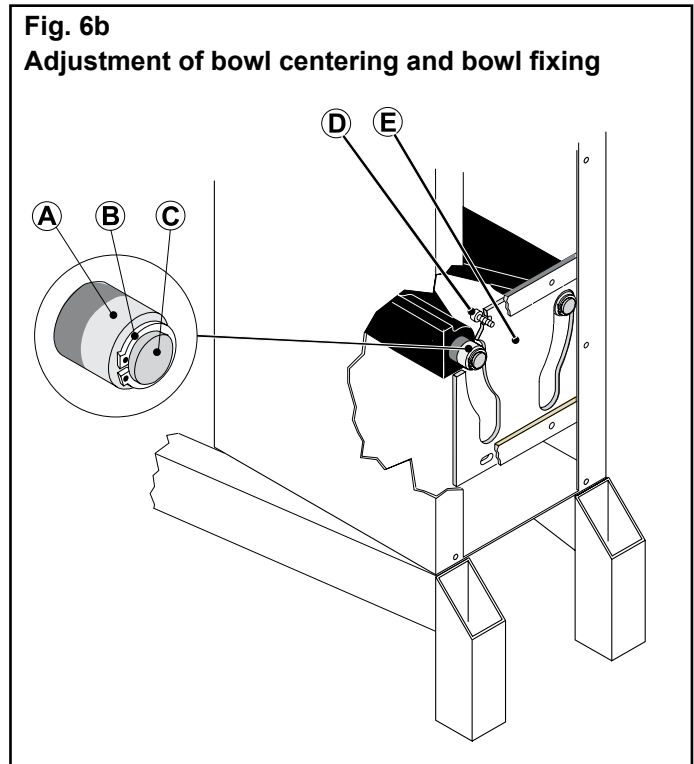
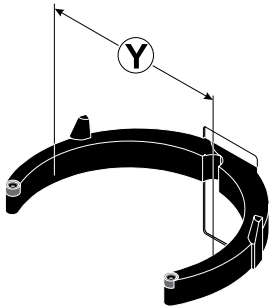

## **MEASURING OF BOWL HEIGHT:**

The distance (X) is measured from the bottom side of the bayonet hole to the surface on the bowl arms on which the bowl rests (**Fig. 7a**). The bowl arms must be lifted to normal working position.

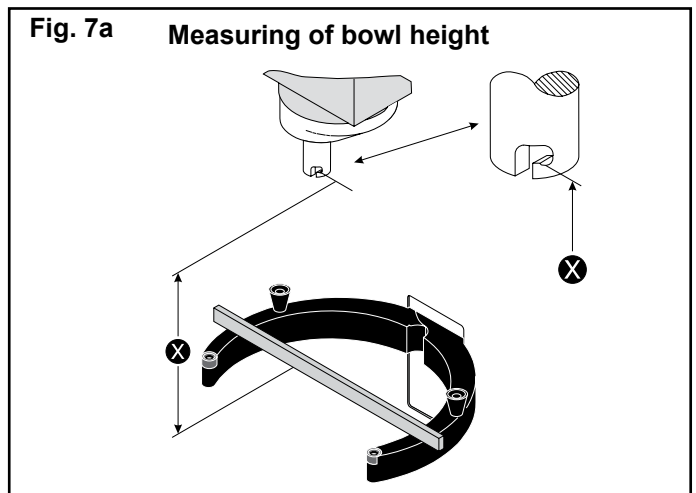

Bowl height (X):	V80	=	233 mm
	V100	=	297 mm

## **ADJUSTMENT OF BOWL HEIGHT (BASIC MIXER):**

Lower the bowl arms down on a wooden block so that the weight of the bowl arms are not loading the lifting system. Loosen the counter nut (1), (Fig. 8a). Take out the spring cotter pin (2). Take out the lifting pin (3). The lifting rod (4) is now loose and can be turned further out or into the lifting nut (5), until the correct height of the bowl arms has been reached. Parts are assembled and the counter nut tightened, so the lifting rod holds the correct position.

**Fig. 8a**  
**Adjustment of bowl height (VL-1):**

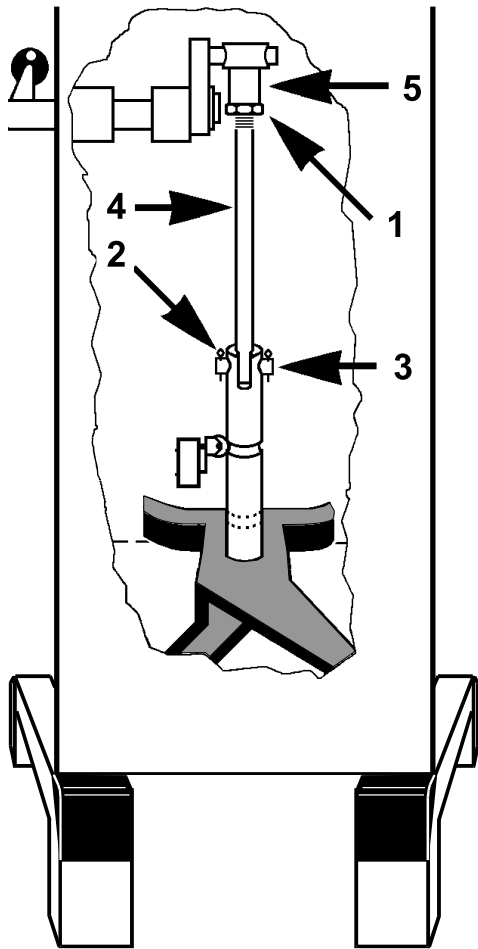

## **ADJUSTMENT OF BOWL HEIGHT (POWER LIFT):**

The upper and lower position of the bowl is determined by the switch top (1), (Fig. 8b) and bottom (2). In the event of a fault in the switch function, the machine has fixed stop (3) and (4). Fixed stop is set from the factory.

In the event of an incorrect bowl height, for example after replacing of switches, the height of the rail with switches is adjusted so that the top switch is activated 1 mm before the fixed stop.

It must be ensured that the bottom switch is activated minimum 1 mm before the fixed stop.

**Fig. 8b**  
**Adjustment of bowl height (VL-1L, VL-1S):**

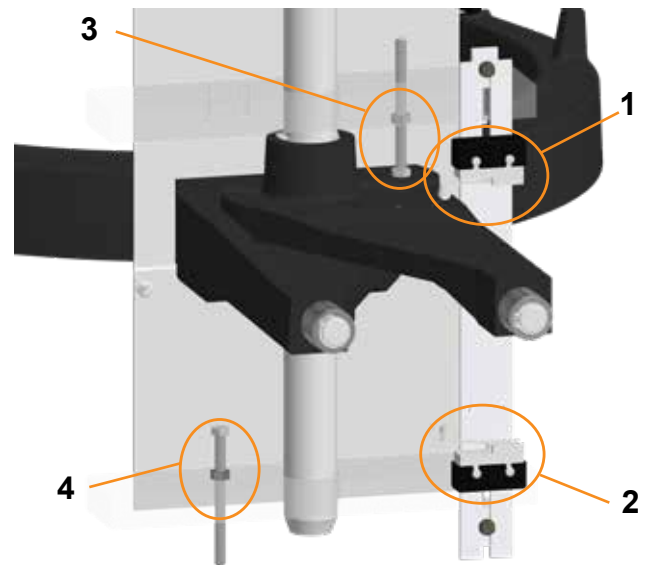

**LIST OF ERRORS:** (In case of other errors, contact the supplier.) **POSSIBLE SOLUTION:**

*A rattling sound from the closed part of the mixer.*

***Adjustment of special V-belt***

*"The mixer starts "striking" when kneading dough which normally causes no problems."*

***Adjustment of special V-belt***

*The mixer changes its speed by itself.*

***Adjustment of special V-belt***

*The minimum and the maximum speeds are changing.*

***Adjustment of speed.***

*The bowl is too tight or too loose.*

***Adjustment of bowl fixing***

*The tool hits the sides of the bowl.*

***Adjustment of bowl centring***

*The tool hits the bottom of the bowl.*

***Adjustment of bowl height***

**ERROR CODES SHOWN ON THE DISPLAY:**

**OL:**

The motor protection relay has stopped the machine and **OL** is shown in the display for 'overload'

- Allow the machine to cool down.
- If the machine does not change to normal mode, the relay has to be manual reset .
- See section "Manual reset of motor protection relay" on page 15.

**EE1:**

If the bowl is not in the correct position when the Start button is pressed, **EE1** will appear on the display.

- Place the bowl in the cradle. Raise cradle and bowl to the correct position.

**EE2:**

If the safety guard is not fitted correctly or closed when the Start button is pressed, **EE2** will appear on the display.

- Check that the safety guard is closed correctly.

**EE6:**

If the machine display shows **EE6** when the Start button is pressed, it means the start relay was not activated correctly.

- Contact a technician to check the start relay.

**ELECTRICAL FUSE (BASIC MIXER):**

The machine is protected by a fuse. The fuse is built into the back of the control panel.



## **MANUAL RESET OF MOTOR PROTECTION RELAY, (BASIC MIXER):**

The motor protection relay is located behind the control panel.

### **To access the motor protection relay:**

Disconnect power from the machine.

Dismount the top lid.

Unplug cables to control panel.

Remove the four nuts holding the control panel, (AF 8 mm) [AF = Across Flats]

Dismount the control panel

Unscrew the four nuts (AF 8 mm) from the black cover box.

Gently lift the cover box off, the motor protection relay is placed inside the cover box

Reset the relay by pushing the red button on top of the relay.

Assembly in reverse order.

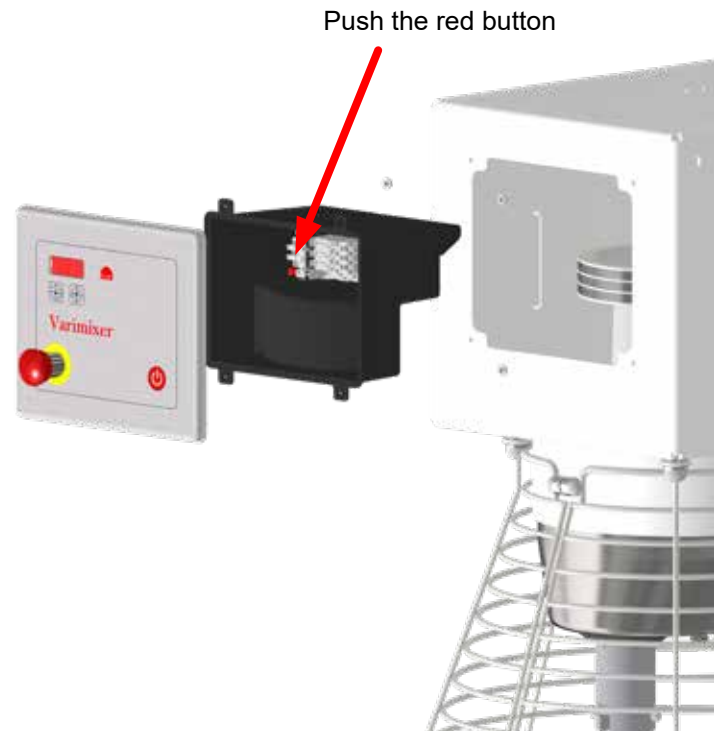

## **MANUAL RESET OF MOTOR PROTECTION RELAY (POWER LIFT MIXER):**

The motor protection relay is located inside the bottom of the machine, inside the enclosure box.

### **To access the motor protection relay:**

Disconnect power from the machine.

Dismount the bag cover plate.

Unscrew the enclosure cover.

Reset the relay by pushing the red button on top of the relay.

Assembly in reverse order.

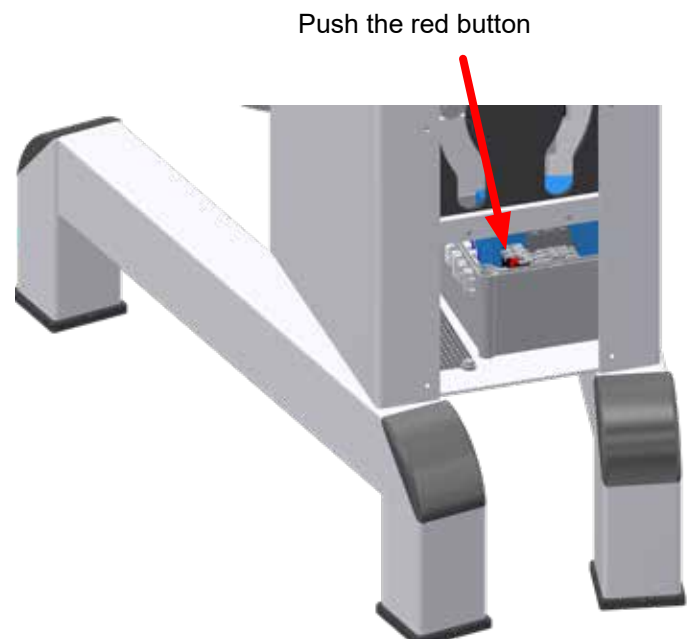

# PRINCIPLE ELECTRICAL DIAGRAM 1-2, MAIN MOTOR (BASIC MIXER):

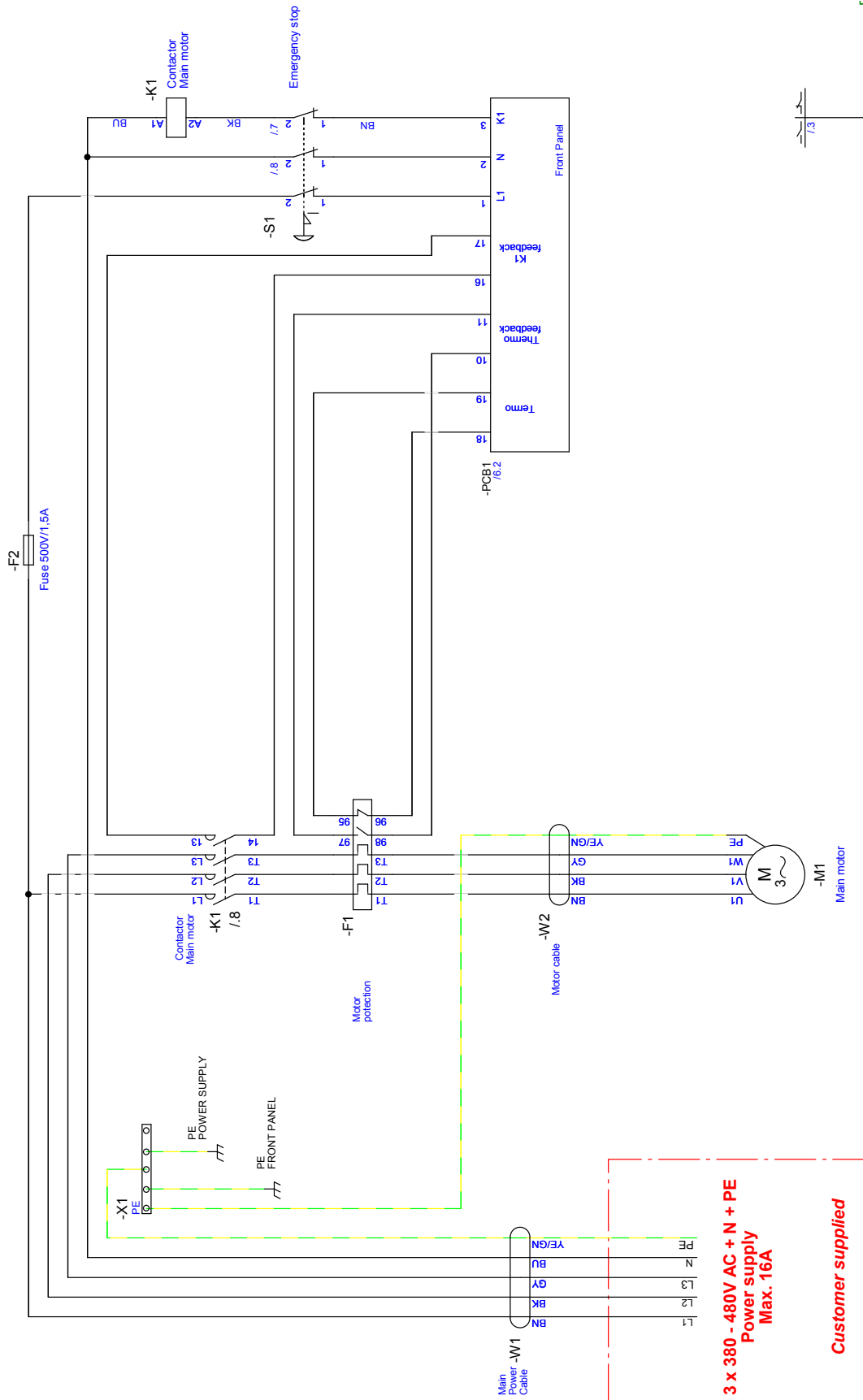

# PRINCIPLE ELECTRICAL DIAGRAM 1-3, MAIN MOTOR (POWER LIFT):

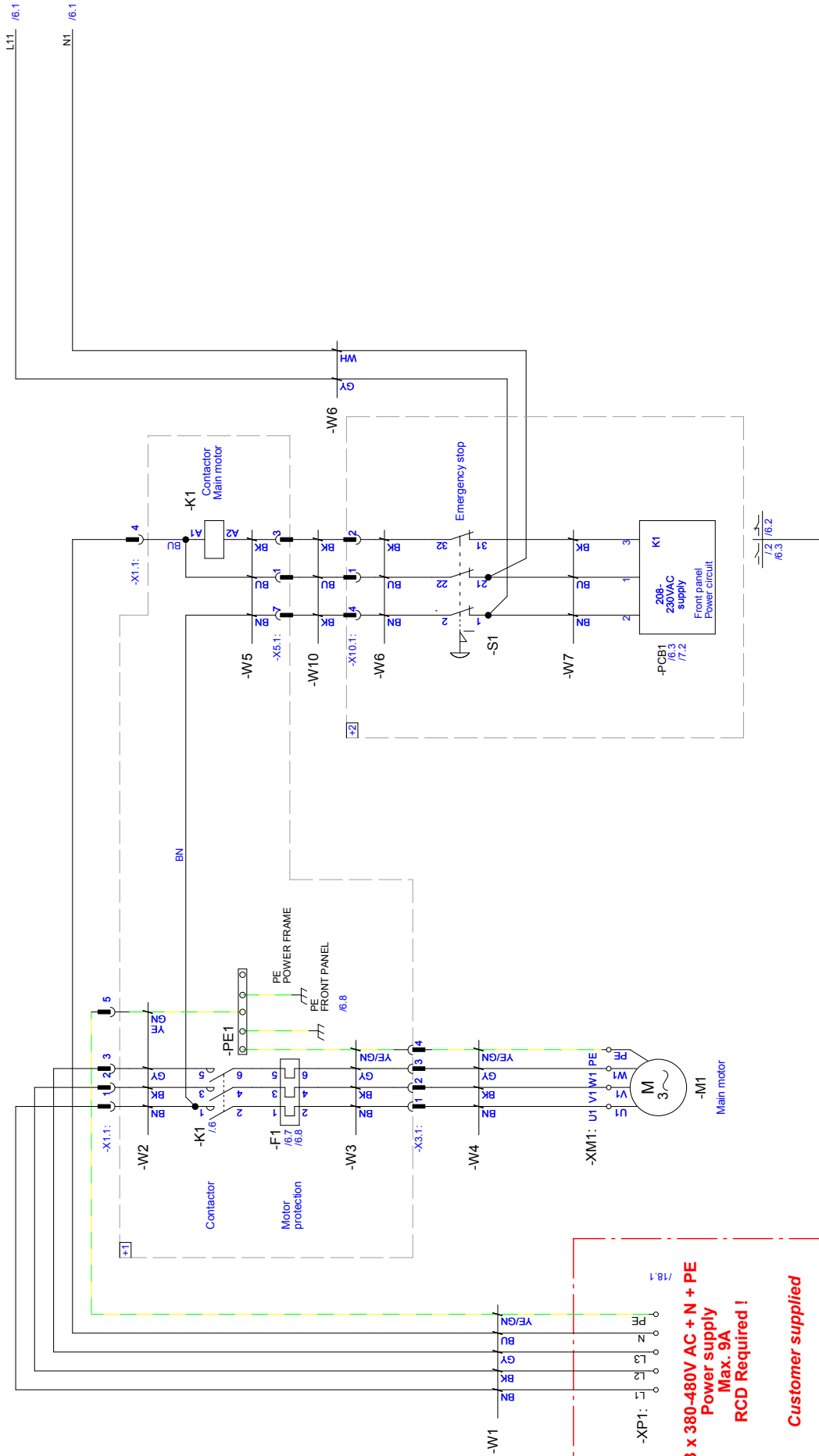

**3 x 380-480V AC + N + PE**  
**Power supply**  
**Max. 9A**  
**RCD Required !**  
**Customer supplied**



**PRINCIPLE ELECTRICAL DIAGRAM, SAFETY CIRCUIT  
(2-2 BASIC MIXER + 3-3 POWER LIFT):**

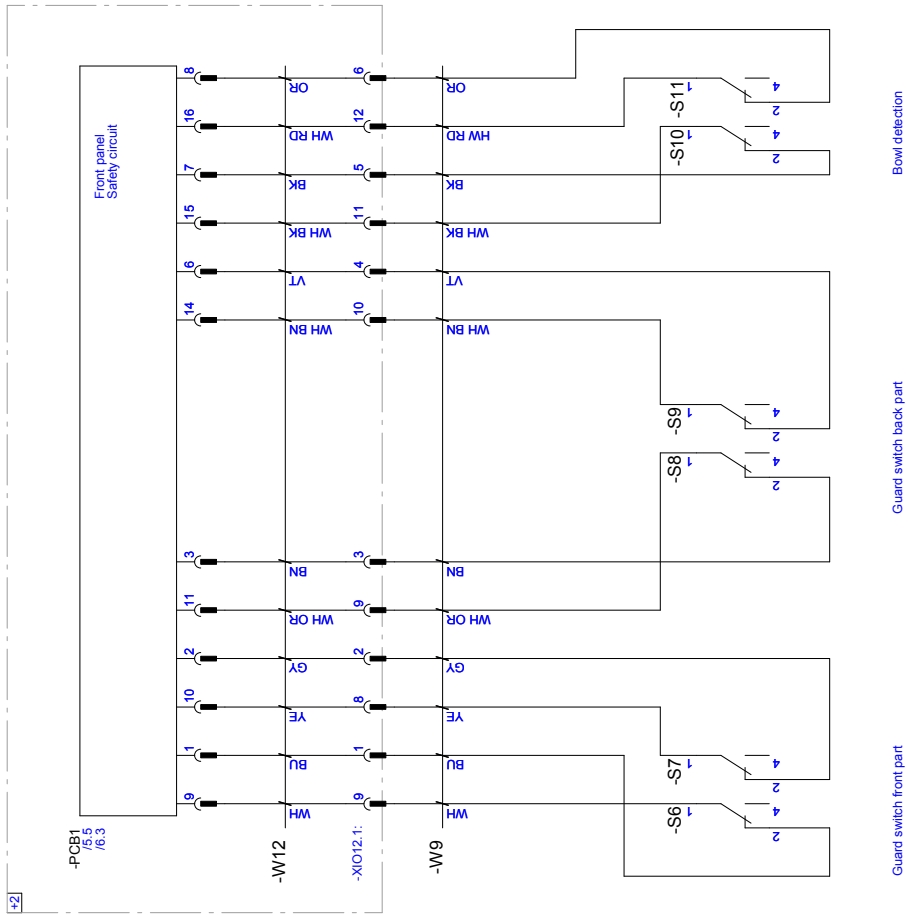

## Cleaning guide for Varimixer V80 and V100

A risk assessment must always be used for all cleaning processes involved in food production.

Based on current legislation, Varimixer A/S<sup>1</sup> has compiled the table below as an aid to devising customer-specific cleaning plans. The importance of cleaning in individual zones of the mixer is illustrated using colours. \*

The mixer's parts mainly consist of stainless steel EN1.4301 (AISI 304). To avoid the steel corroding, the following guidelines must be followed:

- Chloride (Cl<sup>-</sup>) content under 50 ppm at temperatures up to 80°C.
- Never use hard steel wool/sponges or other hard objects that can scratch the steel surface.
- After using chemicals, the mixer must always be washed off with clean water of drinking-water quality.

The bowl ring and certain tools are made of aluminium:

- When washing aluminium, pH value must be kept between 5.0 and 8.0.

Remove all safety guards and tools before starting cleaning.



- \*  **Non- food contact zone.** = Low risk.  **Splash zone.** = Moderate risk.  **Direct food contact zone.** = High risk.

### Cleaning step-by-step

<b>Bowl.</b>	Empty the bowl and rinse with water. Put bowl in the dishwasher, or wash by hand with a soft sponge or brush. <b>NB: The bowl ring is aluminium.</b>
<b>Tools.</b>	Remove any food residue from tools, and rinse with water. <b>NB: Never tap the whip against the bowl lip or other objects.</b> Wash tools by hand or in a dishwasher. Always remove the stainless steel part of the scraper blade before cleaning. <b>NB: Some tools can be aluminium.</b>
<b>Safety guards.</b>	Wash safety guards by hand or in a dishwasher.
<b>Bayonet housing.</b>	Always check the bayonet where tools are attached for food residues. A damp cloth or sponge can be inserted into the bayonet to loosen food residues.
<b>Front panel.</b>	Wipe off the front panel with a lightly-wrung cloth. Remember the emergency stop.
<b>Mixer/stand.</b>	Always wash the mixer with the bowl clamping system in open and closed position.

<sup>1</sup> DS/EN 454: 2014, DS/EN 1672-2:2020, etc.

<b>Bowl clamping system.</b>	<p>The mixer is classified to IP32. It must therefore only be wiped using a well-wrung damp cloth.</p> <p><b>NB: Never spray water on the machine.</b></p> <p>Machines with the upgraded version IP-44 can be washed using foam. Rinsing-off must be restricted to thin streams of water, equivalent to normal rain. The water must be clean water of drinking-water quality.</p>
<b>Lift arm and speed control.</b>	<p>Always wash the bowl clamping system in open and closed position. Wash the bowl clamping system using a well-wrung damp cloth as for washing the stand.</p> <p>Dry the rollers for the bowl catch to remove water and cleaning chemicals.</p>
<b>Storage.</b>	<p>Wipe off the lift arm and speed control with a well-wrung damp cloth.</p> <hr/> <p>The bowl can be fitted on the mixer after cleaning. If the bowl is stored on the mixer, we recommend covering it.</p> <p><b>NB: To avoid steel corrosion, never store foods with high concentrations of acid or salt in the bowl.</b></p>

## Disinfection

Disinfection requires strong chemicals. Always perform an assessment of whether disinfecting the mixer will make any difference to food safety for the end product.

**NB: Always obtain the recommendations from the supplier/manufacturer of cleaning/disinfection products before use.**

If water is left from cleaning and disinfection to evaporate on the mixer surface, the concentration of chlorides and other chemicals will be higher than during the cleaning process. Always rinse and wipe off the mixer with clean water of drinking-water quality after using chemicals.

All oxidising chemical disinfectants require rinsing off with clean water of drinking-water quality. Without access to clean water of drinking-water quality, disinfection using hot water, steam and disinfecting using IPA ethanol and ethanol can be used.

**NB: Always obtain a written declaration from the supplier/manufacturer of the disinfectant that it is safe and can be used without rinsing off using clean water of drinking-water quality.**

Incorrect use of disinfectants can damage the mixer.

## Acid-proof stainless steel

When producing strongly acidic and/or products with a high salt content, and when cleaning using strong chemicals, we recommend buying the mixer bowl and tools in acid-proof stainless steel EN 1.4401 (AISI 316).

Acid-proof stainless steel is more corrosion-resistant, and by way of comparison tolerates chloride (Cl<sup>-</sup>) concentrations below 50 ppm at temperatures up to 100°C.

For more details on cleaning Varimixer A/S mixers, refer to our website: <https://varimixer.com/>

This page intentionally left blank

This page intentionally left blank



# Varimixer

---

Varimixer A/S  
Elementfabrikken 9  
DK-2605 Brøndby  
P: +45 4344 2288  
E: [info@varimixer.com](mailto:info@varimixer.com)  
[www.varimixer.com](http://www.varimixer.com)