

**03TA**  
**TUBE-ICE<sup>®</sup>**  
**MACHINE**

**(Includes models HE60 & P112F)**

**Part Number [12A4171M07](#)**  
**Revision 3**

**Service Manual**  
**\$50<sup>00</sup>**

# NOTICE

This manual is the property of the owner of this particular Tube-Ice® machine.

Model # \_\_\_\_\_ Serial # \_\_\_\_\_.

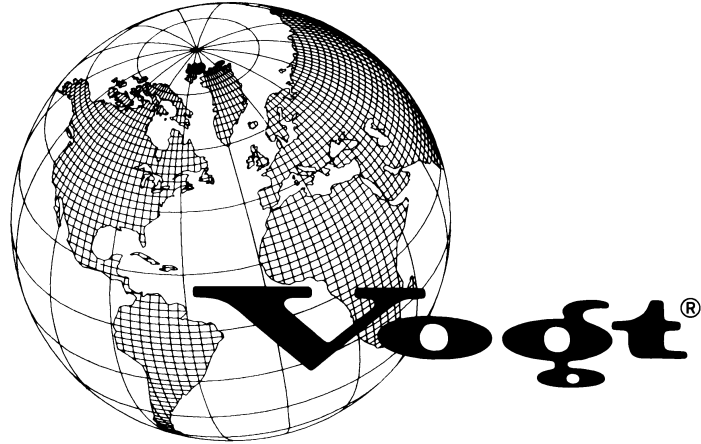
It is to be left on the premises with this machine at all times. After start-up, it should be stored in a safe place where it can be readily available when needed for future reference in maintaining troubleshooting or servicing.

Failure to comply with this notice will result in unnecessary inconvenience and possible additional expenses.

This manual is intended as an informational tool for the installation, operation, maintenance, troubleshooting, and servicing of this equipment. If an existing situation calls for additional information not found herein, we suggest that you contact your distributor first. If further assistance or information is needed, please feel free to contact the factory at 502-635-3000 or FAX at 502-635-3024.

**IMPORTANT:** To activate the machine warranty, the Product Registration Form **MUST** be completed and returned to the factory promptly after the official start-up. Product Registration Form is located in the Owners Packet or can be found online at [www.vogtice.com/registration.htm](http://www.vogtice.com/registration.htm).

Please return to:            VOGT ICE® , LLC  
                                 Suite #19  
                                 1000 W. Ormsby Ave.  
                                 Louisville, KY 40210



**VOGT ICE®**, LLC, located in  
**Louisville, Kentucky since 1880.**

**Sales** - (800) 959-8648

**Service** - (502) 635-3000

**Parts** - Your Local Distributor

Call your local distributor **first** for all of your parts and service needs.

Since 1880, Manufacturers of Quality  
Tube-Ice® Machines

Vogt<sup>®</sup>  
Tube-Ice<sup>®</sup> Machines

Installation, Service Manual and Parts Catalog #12A4171M07  
03TA Model

Revision 3.0

# TABLE OF CONTENTS

## *Vogt*<sup>®</sup> TUBE-ICE<sup>®</sup> MACHINES Model 03TA

	<b>Page No.</b>
<b><u>1. INTRODUCTION</u></b>	
A Brief History of Our Company .....	1-1
Vogt Energy-Savings Tube-Ice <sup>®</sup> Machines .....	1-1
Preview .....	1-1
Important Safety Notice.....	1-2
Special Precautions To Be Observed When Charging Refrigeration Systems.....	1-2
Safety Symbols and What They Mean.....	1-3
Assembly Drawing Model 03TB Air-Cooled, FIGURES 1-1, 1-2, & 1-3.....	1-4, 1-5, 1-6
Assembly Drawing Model 03TB Water-Cooled, FIGURES 1-4, 1-5, & 1-6 .....	1-7, 1-8, 1-9
<b><u>2. RECEIPT OF YOUR TUBE-ICE MACHINE</u></b>	
Inspection .....	2-1
Safety Valves.....	2-1
Machine Room .....	2-1
Storage (prior to installation and start-up) .....	2-2
<b><u>3. INSTALLING YOUR TUBE-ICE MACHINE</u></b>	
Bin Installation .....	3-1
Setting the Ice Machine on the Bin.....	3-1
Ice Chute Location/Machine Footprint, FIGURE 3-1.....	3-1
Forklift and Blocks Method, FIGURE 3-2 .....	3-2
Forklift and Ropes or Lifting Strap Method, FIGURE 3-3 .....	3-3
Connections and Space Diagram (Air-Cooled Machine), FIGURE 3-4 .....	3-4
Connections and Space Diagram (Water-Cooled Machine), FIGURE 3-5.....	3-5
Piping and Drain Connections .....	3-6
Water Supply and Drain Sizes, TABLE 3-1 .....	3-6
Cooling Tower.....	3-7
Wiring and Electrical Connection.....	3-8
Control Panel Power Connections, FIGURE 3-6.....	3-8
Electrical Specifications, TABLE 3-2 .....	3-8
Phase Check.....	3-9
Voltage Unbalance.....	3-9
Current Unbalance.....	3-9
Air-Cooled Condenser Installation Instructions.....	3-10
Pounds of Refrigerant To Add Vs. Liquid Line Length, TABLE 3-3.....	3-11
Air-Cooled Condenser Data.....	3-12
Condenser Dimensions, FIGURE 3-7.....	3-13
Condenser Field Piping (Cold Weather Valve Kit), FIGURE 3-8.....	3-14

## TABLE OF CONTENTS

	<b>Page No.</b>
<b><u>3. INSTALLING YOUR TUBE-ICE MACHINE (Cont.)</u></b>	
Condenser Equivalent Line Size Worksheet.....	3-15
Equivalent Feet Due To Friction, TABLE 3-5.....	3-15
Minimum Traps For Discharge Lines, FIGURE 3-9 .....	3-15
Air-Cooled Condenser Wiring.....	3-16
Wiring for 2 Fan Condenser, FIGURE 3-10.....	3-16
Air-Cooled Connections .....	3-17
Rota-lock Connector Torque Ratings, TABLE 3-6.....	3-17
Pressure Relief Valves.....	3-17
Ice Bin Thermostat Sensor Installation.....	3-18
Ice Bin Thermostat Location, FIGURE 3-11 .....	3-18
Programming the Electronic Ice Bin Thermostat.....	3-19
Storing Ice .....	3-20
Saigle Ice / Dual Ice .....	3-20
Installation Review : A Checklist .....	3-21
<b><u>4. HOW YOUR TUBE-ICE MACHINE WORKS</u></b>	
Principle of Operation.....	4-1
Freeze Period .....	4-2
Harvest Period .....	4-2
Piping Nomenclature, TABLE 4-1 .....	4-2
Water-Cooled Piping Schematic, FIGURE 4-1 .....	4-3
Air-Cooled Piping Schematic, FIGURE 4-2.....	4-4
<b><u>5. START-UP AND OPERATION</u></b>	
Refrigeration System Review .....	5-1
Refrigerant Charge.....	5-1
Start-Up Checklist .....	5-2
Start-Up .....	5-3
Control Panel Switch Layout, FIGURE 5-1 .....	5-3
Adding Refrigerant .....	5-4
Operating Tips .....	5-5
<b><u>6. ELECTRICAL CONTROLS &amp; THEIR FUNCTIONS</u></b>	
Control Panel FIGURE 6-1.....	6-1
Control Panel (Standard), FIGURE 6-2.....	6-2
Control Panel Door, FIGURE 6-2A.....	6-3
Control Panel (Australian & CE approved), FIGURE 6-2B .....	6-4
Description of Control Panel Parts, TABLE 6-1.....	6-5
Description of Control Panel Component Function, TABLE 6-2 .....	6-6
Electrical Schematic All Voltages 50-60 Hz. (Standard/Australian/CE), FIGURE 6-3.....	6-7
Compressor Wiring Detail, FIGURE 6-4.....	6-8

## TABLE OF CONTENTS

## Page No.

**7. MAINTENANCE**

Ice-Making Section.....	7-1
Cleaning Procedure.....	7-1
Sanitizing Procedure .....	7-2
Water Distributors .....	7-3
Water Tank .....	7-3
Water-Cooled Condensers, Checking Operation .....	7-3
Water-Cooled Condensers, Draining .....	7-4
Water-Cooled Condenser Cleaning .....	7-4
Lubrication .....	7-6
Compressor.....	7-6
Cutter Gear Reducer .....	7-7
Preventive Maintenance.....	7-8
Daily /Weekly / Monthly / Yearly Check List.....	7-8
Pressure Relief Valve Replacement Note .....	7-8
Note To Manager or Owner.....	7-9
Preventive Maintenance Program.....	7-10

**8. TROUBLESHOOTING**

List Of Symptoms.....	8-1
Machine Won't Run .....	8-2, 8-3
Freeze-Up Due To Extended Freezing Period .....	8-4
Freeze-Up Due To Ice Failing To Discharge.....	8-5
Low Ice Capacity.....	8-6
Low Compressor Oil Level.....	8-7
Poor Ice Quality.....	8-8
High Head Pressure (Water-Cooled) .....	8-9
High Head Pressure (Air-Cooled).....	8-10

**9. SERVICE OPERATIONS**

Adjustable Blowdown (For Clearer Ice).....	9-1
Water Pump/ Blowdown Assembly, FIGURE 9-1 .....	9-1
Automatic Blowdown (Harvest Cycle).....	9-1
Float Valve (Make-Up Water).....	9-1
Thermal Expansion Valve, FIGURE 9-2.....	9-2
Superheat / Checking Superheat .....	9-2
Freezer Pressure Switch.....	9-3
Freezer Pressure Switch (Allen-Bradley), FIGURE 9-3 .....	9-3
High-Low Pressure Switch .....	9-4
High-Low Pressure Switch, FIGURE 9-4.....	9-4
Head Pressure .....	9-4
Water-Cooled Units.....	9-4
Air-Cooled Units .....	9-5
Water Regulating Valve, FIGURE 9-5A .....	9-5
Condenser Fan Switch, FIGURE 9-5B.....	9-5

## TABLE OF CONTENTS

	<b>Page No.</b>
<b>9. <u>SERVICE OPERATIONS (Cont.)</u></b>	
Oil Separator, FIGURE 9-6 .....	9-6
Solenoid Valve .....	9-5
Solenoid Valve ("D" & "X" Valve Before Aug 2006), FIGURE 9-7A .....	9-6
Solenoid Valve ("D" & "X" Valve After Aug 2006), FIGURE 9-7B .....	9-6
Solenoid Valve ("A" Valve), FIGURE 9-7C .....	9-6
Compressor Crankcase Heater .....	9-7
Compressor Connections, FIGURE 9-8 .....	9-7
Sentronic Oil Pressure Safety Control, FIGURE 9-9A .....	9-8
Oil Pressure Sensor .....	9-9
Sentronic Oil Pressure Safety Control .....	9-8
CoreSense Protection .....	9-9
CoreSense Protection Faults / Connection, Figure 9-9B .....	9-10
Control Circuit Protection .....	9-10
Circulating Water Pump Motor, FIGURE 9-10 .....	9-11
Cutter Gear Reducer, FIGURE 9-11 .....	9-11
Thawing Timer, FIGURE 9-12A .....	9-12
Thawing Timer Pin Connections, FIGURE 9-12B .....	9-12
Condenser Cleaning .....	9-13
Pump Down .....	9-13
Removal Of Refrigerant From Machine .....	9-13
Refrigerant Leaks .....	9-14
Non-Condensable Gases .....	9-14
Compressor Motor Burnout .....	9-15
Capacity Control Valve (Internal Construction) .....	9-16
Copeland Compressor Unloader Valve, FIGURE 9-13 .....	9-16
Loaded Operation (Freeze Period), Unloaded Operation (During Thaw Only) .....	9-16
Component Removal and Replacement Operations .....	9-17
Cutter Motor .....	9-17
Water Tank .....	9-18
Cutter & Bearing .....	9-18
Cutter/Tank Assembly Nomenclature, TABLE 9-1 .....	9-19
Cutter, Water Tank & Drive Gear Assembly, FIGURE 9-14 .....	9-20
Water Tank & Pump Assembly, FIGURE 9-15 .....	9-21
Crushed Ice Production .....	9-22
<b>10. <u>OPTIONS AND ACCESSORIES</u></b>	
Power Monitor, FIGURE 10-1 .....	10-1
Power Monitor Parameters, TABLE 10-1 .....	10-1
PLC (Programmable Logic Controller) .....	10-4
Mitsubishi HMI (E1012), FIGURE 10-2 .....	10-5
PLC, FIGURE 10-3 .....	10-6
PLC, Input / Output Table, TABLE 10-2 .....	10-6
Wiring Schematic, FIGURE 10-24 .....	10-6

## TABLE OF CONTENTS

## Page No.

**11. TABLES AND CHARTS**

03TA Ratings (60 Hz., 7.5 HP), TABLE 11-1.....	11-1
03TA Ratings (50 Hz., 10 HP), TABLE 11-1.....	11-1
03TA Capacity Ratings, TABLE 11-2.....	11-2
03TA Condenser Water Usage, TABLE 11-3 .....	11-3
03TA Make-up Water Usage, TABLE 11-4.....	11-3
03TA Normal Operating Vitals, TABLE 11-5.....	11-3
Recommended Spare Parts List .....	11-4
Temperature - Pressure Chart for Common Refrigerants, TABLE 11-6.....	11-5
Conversion Factors: English to Metric, TABLE 11-7 .....	11-6
Constants, TABLE 11-8 .....	11-6

**12. INDEX**

Blank page

# 1. Introduction

## VOGT ICE<sup>®</sup>, LLC

**A Brief History Of Our Company.** Henry Vogt Machine Co. was founded as a small machine shop in Louisville, Kentucky in 1880. In 1938, Vogt built the first Tube-Ice<sup>®</sup> machine and revolutionized the ice-making industry. Our first “sized-ice” machine quickly replaced the old can-ice plants, which required much hard labor and large amounts of floor space for freezing, cutting, and crushing ice by hand.

Today , VOGT ICE<sup>®</sup>, LLC carries on the tradition as one of the world’s leading producers of ice-making equipment.

**Vogt Energy-Saving Tube-Ice Machines Are Cost Effective.** Today, Vogt Tube-Ice<sup>®</sup> machines enjoy a well-earned reputation as the most energy efficient, dependable ice-making equipment in the world.

Using as little as one-half to one-third the energy required by competitors’ icemakers, Tube-Ice<sup>®</sup> machines produce the same amount of ice--in restaurants, sports arenas, packing plants, and wholesale operations around the globe--at great savings.

In addition, Tube-Ice<sup>®</sup> machines are renowned for their long life, giving many customers more than 35 years of dependable service. Ask someone who owns one.

**Preview.** All the skill in engineering and fabrication that we have learned in over a century of experience, is reflected in the 03TA model Tube-Ice<sup>®</sup> machines. Since Vogt introduced Tube-Ice<sup>®</sup> machines in 1938, the process of making Tube-Ice<sup>®</sup> ice has been widely recognized as the most economical means of production. The machine’s economic and reliable operations have been proven over and over again, in a network of varied types of installations throughout the world.

Furnished with your machine is the “Certificate Of Test”--the report of operating data that is a record of the unit’s satisfactory operation on our factory test floor. It is evidence of our desire to deliver to you “the finest ice-making unit ever made.”

This manual is designed to assist you in the installation, start-up, and maintenance of your unit. Your Tube-Ice<sup>®</sup> machine will give you a lifetime of service when you install it, maintain it, and service it properly.

Please read your manual carefully before attempting installation, operation, or servicing of this professionally designed piece of equipment.

If you have additional questions, please call your distributor. Also, feel free to phone the factory direct at **(502) 635-3000 OR 1-800-853-8648**.

## INTRODUCTION

**Important Safety Notice.** This information is intended for use by individuals possessing adequate backgrounds of electrical, refrigeration and mechanical experience. Any attempt to repair major equipment may result in personal injury and property damage. The manufacturer or seller cannot be responsible for the interpretation of this information, nor can it assume any liability in connection with its use.

**Special Precautions To Be Observed When Charging Refrigeration Systems.** Only technically qualified persons, experienced and knowledgeable in the handling of refrigerant and operation of refrigeration systems, should perform the operations described in this manual. All local, federal, and EPA regulations must be strictly adhered to when handling refrigerants.

If a refrigeration system is being charged from refrigerant cylinders, disconnect each cylinder when empty or when the system is fully charged. A gage should be installed in the charging line to indicate refrigerant cylinder pressure. The cylinder may be considered empty of liquid R-22/404A refrigerant when the gauge pressure is 25 pounds or less, and there is no frost on the cylinder. Close the refrigerant charging valve and cylinder valve before disconnecting the cylinder. Loosen the union in the refrigerant charging line--carefully to avoid unnecessary and illegal release of refrigerant into the atmosphere.

<b>! CAUTION !</b>
--------------------

<p><b>Immediately close system charging valve at commencement of defrost or thawing cycle if refrigerant cylinder is connected. Never leave a refrigerant cylinder connected to system except during charging operation. Failure to observe either of these precautions can result in transferring refrigerant from the system to the refrigerant cylinder, over-filling it, and possibly causing the cylinder to rupture because of pressure from expansion of the liquid refrigerant.</b></p>
---

<b>! CAUTION !</b>
--------------------

Always store cylinders containing refrigerant in a cool place. They should never be exposed to temperatures higher than 125°F and should be stored in a manner to prevent abnormal mechanical shocks.

Also, transferring refrigerant from a refrigeration system into a cylinder can be very dangerous and is not recommended.

<b>! CAUTION !</b>
--------------------

<p><b>It is not recommended that refrigerant be transferred from a refrigeration system directly into a cylinder. If such a transfer is made, the refrigerant cylinder must be an approved, CLEAN cylinder--free of any contaminants or foreign materials--and must be connected to an approved recovery mechanism with a safety shutoff sensor to assure contents do not exceed net weight specified by cylinder manufacturer or any applicable code requirements.</b></p>
---

<b>! CAUTION !</b>
--------------------

**Safety Symbols & What They Mean.** Prior to installation or operation of the Tube-Ice® machine, please read this manual. Are you familiar with the installation, start-up, and operation of a Tube-Ice® machine? Before you operate, adjust or service this machine, you should read this manual, understand the operation of this machine, and be aware of possible dangers.

**These Safety Symbols will alert you  
when special care is needed.**

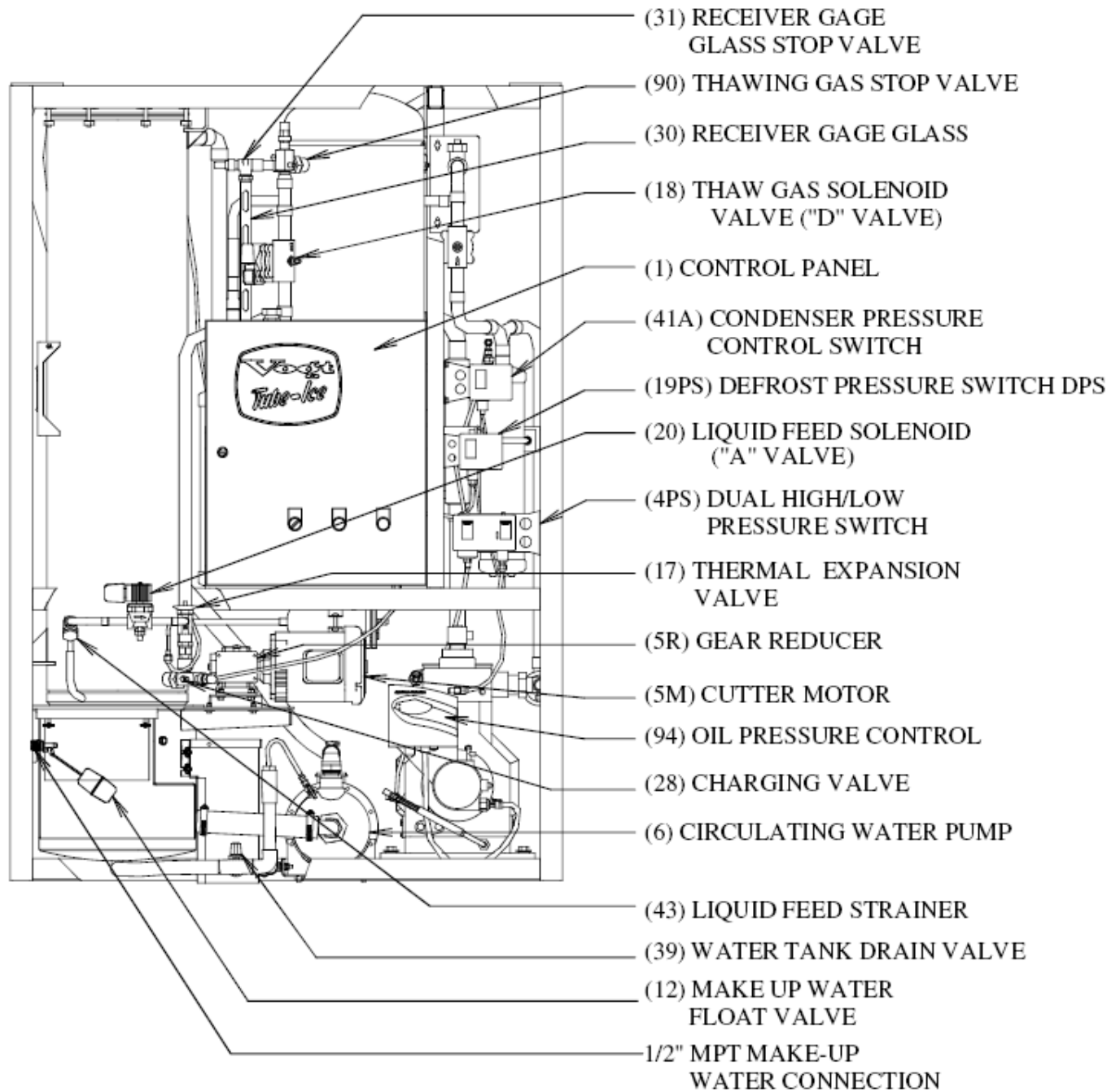
**Please heed.**

<b>! DANGER !</b>
<b>Indicates an immediate hazard and that special precautions are necessary to avoid severe personal injury or death.</b>
<b>! DANGER !</b>

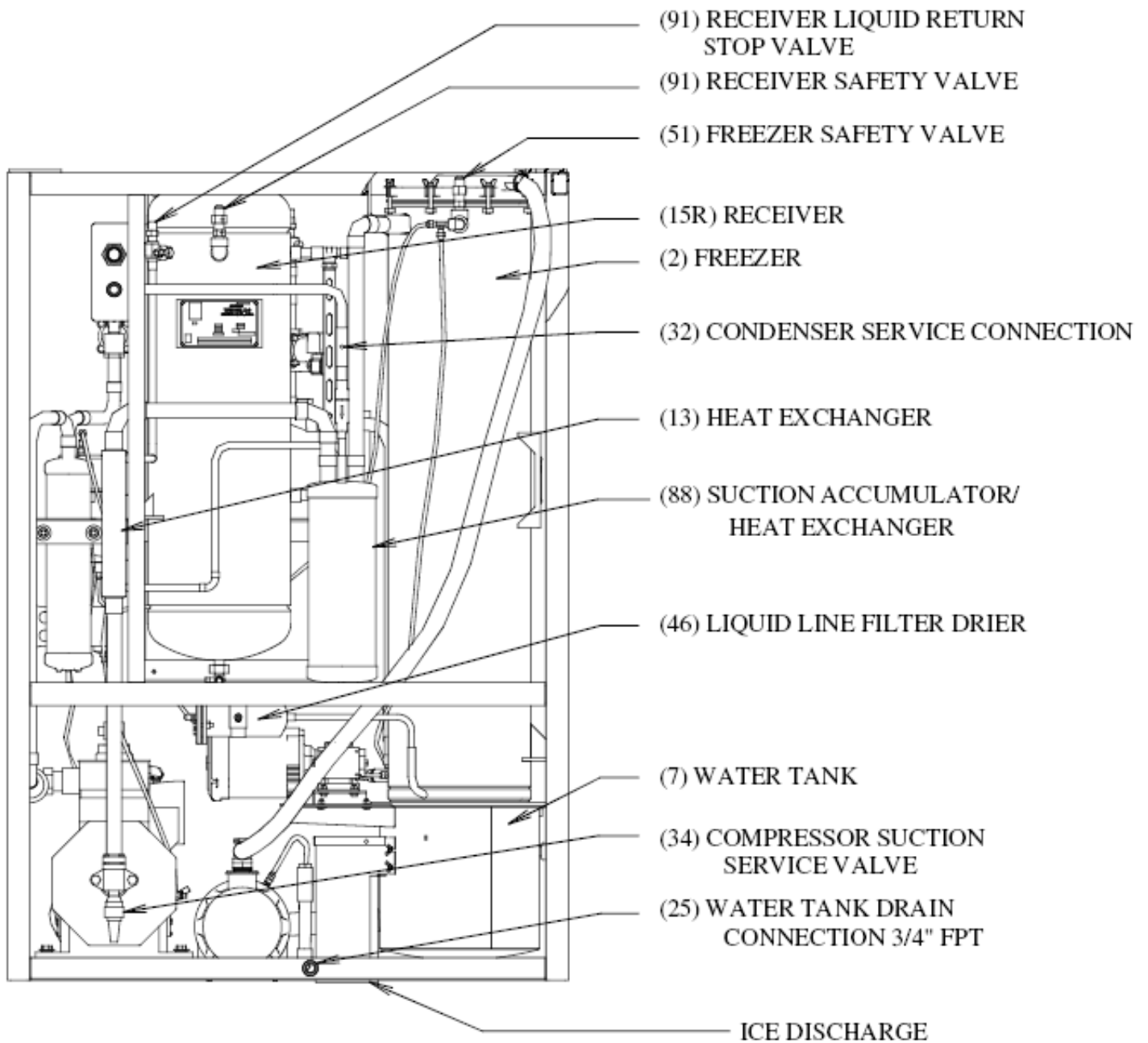
<b>! WARNING !</b>
<b>Indicates a strong possibility of a hazard and that an unsafe practice could result in severe personal injury.</b>
<b>! WARNING !</b>

<b>! CAUTION !</b>
<b>Means hazards or unsafe practices could result in personal injury and/or product and/or property damage.</b>
<b>! CAUTION !</b>

## INTRODUCTION

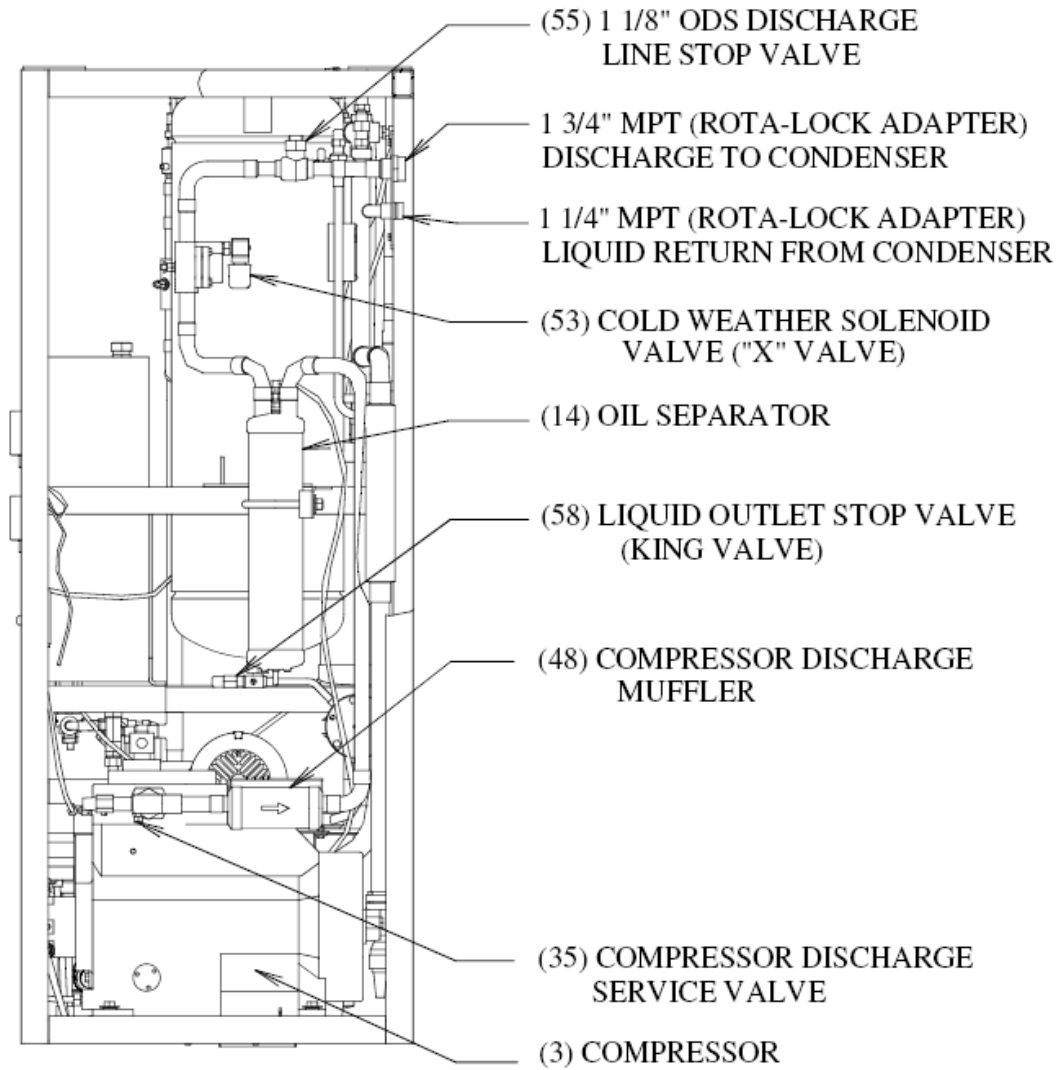


**FIGURE 1-1**  
**Assembly (Air-Cooled)**  
**Front View**

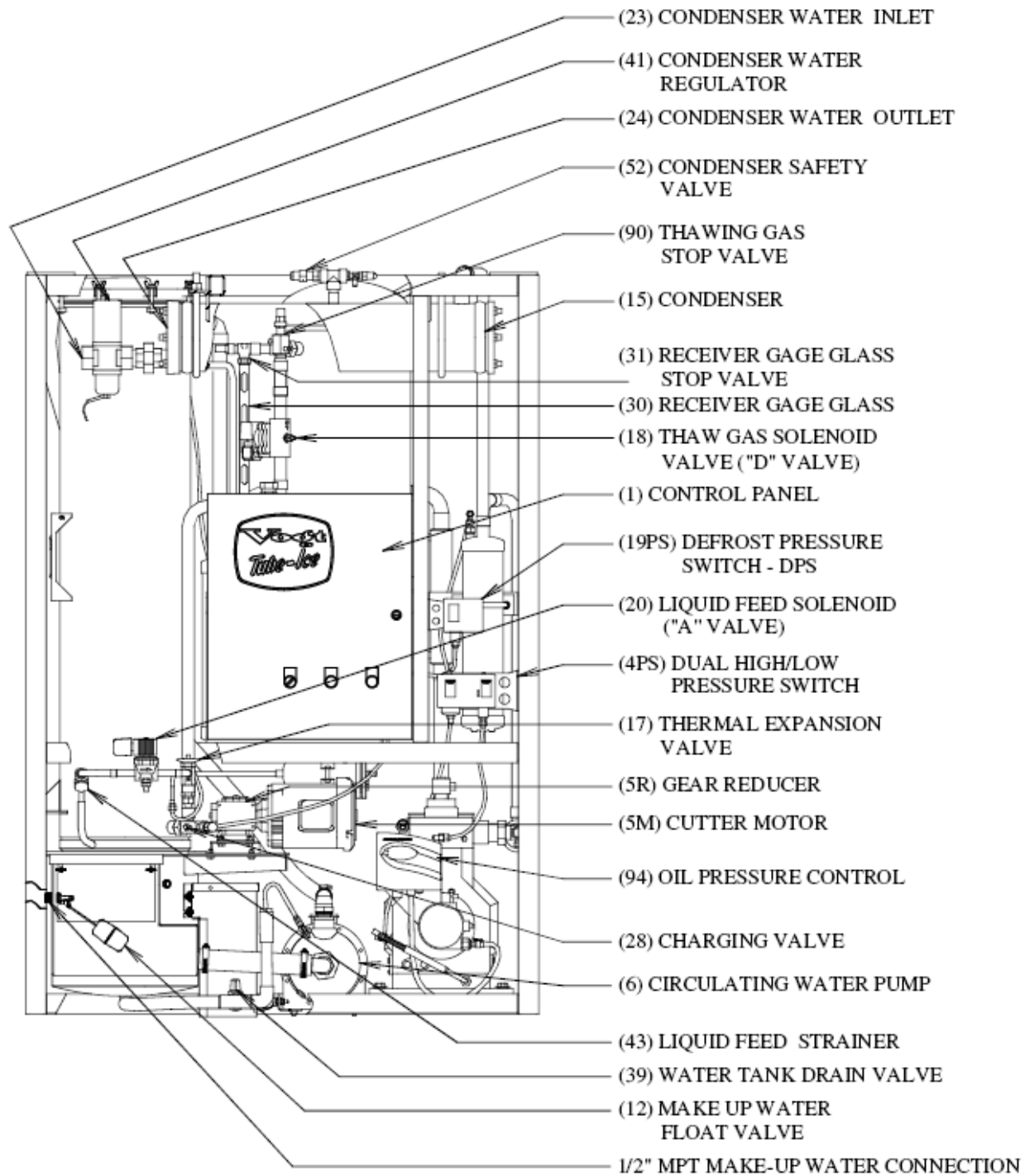


**FIGURE 1-2**  
**Assembly (Air-Cooled)**  
**Rear View**

## INTRODUCTION

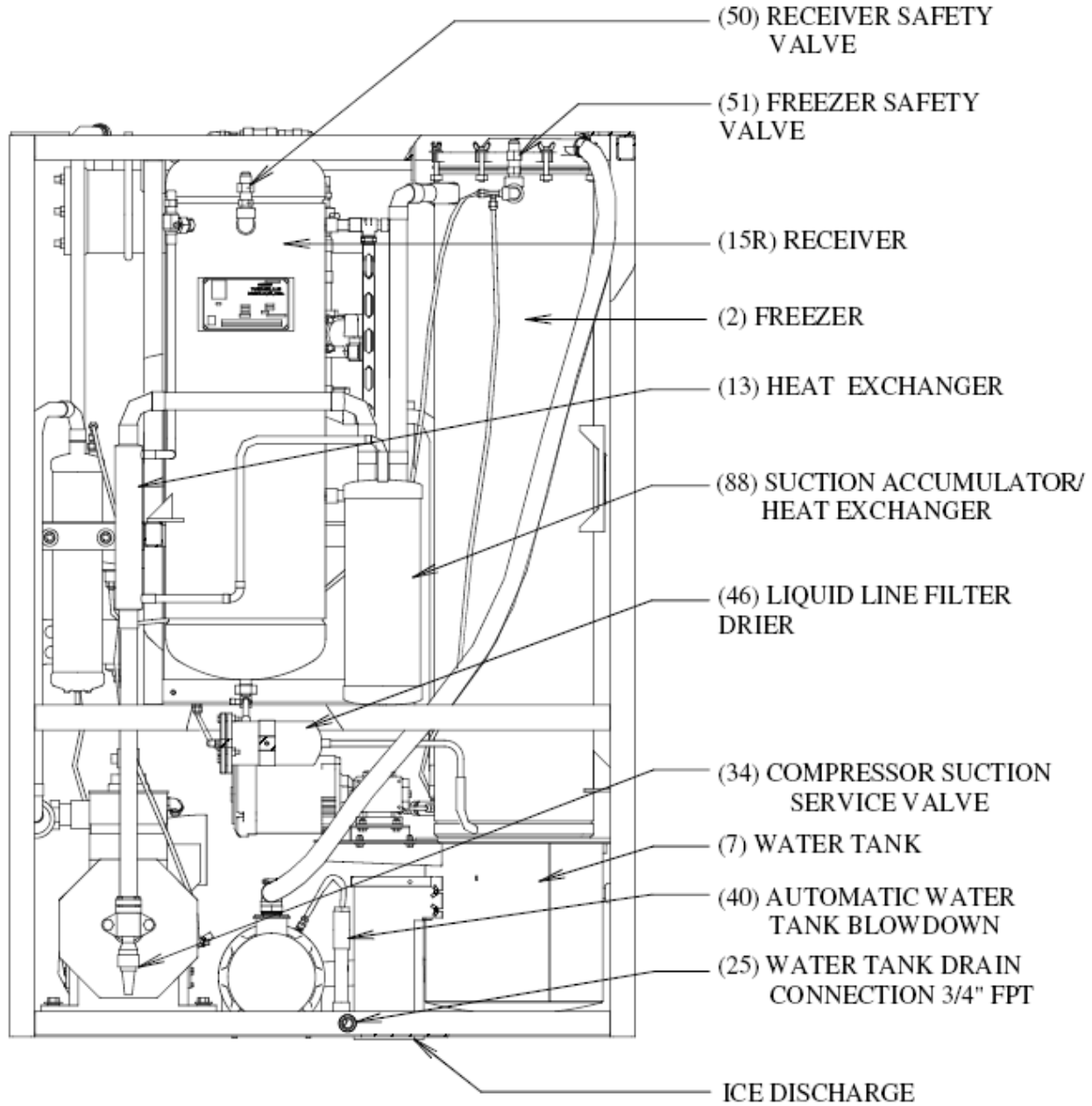


**FIGURE 1-3**  
**Assembly (Air-Cooled)**  
**Right**  
**Side View**

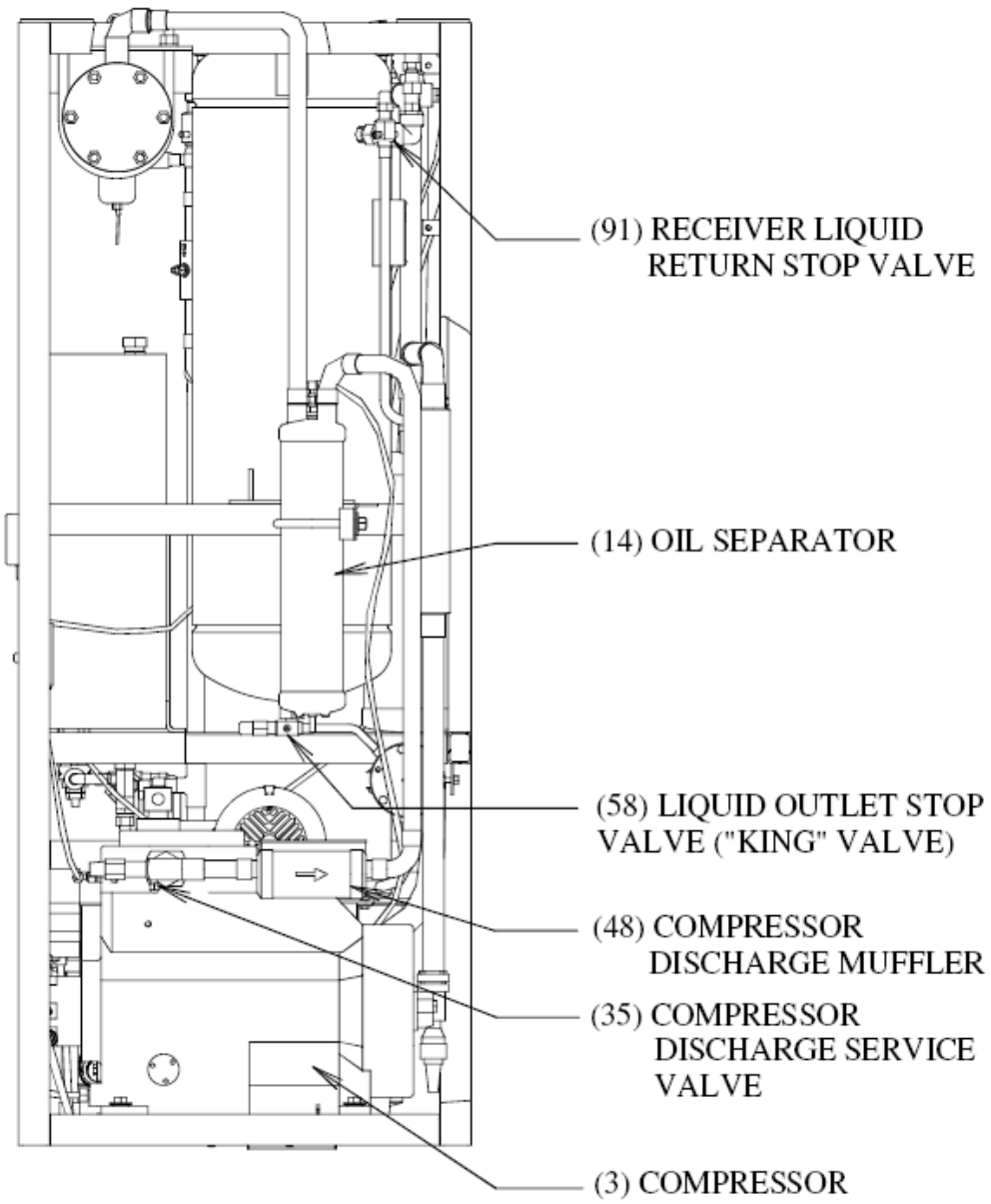


**FIGURE 1-4**  
**Assembly (Water Cooled)**  
**Front View**

INTRODUCTION



**FIGURE 1-5**  
**Assembly (Water Cooled)**  
**Rear View**



**FIGURE 1-6**  
**Assembly (Water Cooled)**  
**Right Side View**

INTRODUCTION

**BLANK**

## 2. Receipt Of Your Tube-Ice Machine

<b>! WARNING !</b>
<b>Only service personnel experienced in refrigeration and qualified to work with high voltage electrical equipment should be allowed to install or work on this Tube-Ice<sup>®</sup> machine.</b>
<b>! WARNING !</b>

**Inspection** As soon as you receive your machine, inspect it for any damage. If damage is suspected, note it on the shipper's papers (i.e., the trucker's Bill of Lading). Immediately make a separate written request for inspection by the freight line's agent. Any repair work or alteration to the machine without the permission of Vogt Ice<sup>®</sup>, LLC can void the machine's warranty.

The machine was shipped with a full charge of refrigerant stored in the receiver. Visually check all lines for mechanical damage. If a leak is suspected, check all joints with a Halogen Leak Detector. All leaks should be reported to Vogt Ice<sup>®</sup>, LLC to obtain authorization for repair.

<b>! CAUTION !</b>
<b>The approximate weight of the machine is 2000 pounds. Always use equipment with adequate load carrying capacity.</b>
<b>! CAUTION !</b>

The machine frame has lifting lugs at each corner in the top for eyebolts and hooks to be used for lifting purposes if desired. Lifting lugs should be used whenever possible.

<b>! CAUTION !</b>
<b>The Tube-Ice<sup>®</sup> machine is top heavy. Secure to avoid tipping.</b>
<b>! CAUTION !</b>

If a forklift is used, make sure its capacity is sufficient. The forks must be wide enough apart to prevent tipping sideways and must extend beyond the extremities of the frame base structure. The machine needs to be bound in place to prevent tipping.

**Safety Valves** Safety pressure relief valves are an integral part of the packaged Tube-Ice<sup>®</sup> machine. One is located in the low-side of the system on the freezer, one is in the high side of the system on the receiver, and one is on the condenser. Vent each of the pressure relief valves to the atmosphere in such a manner as to comply with local and national codes.

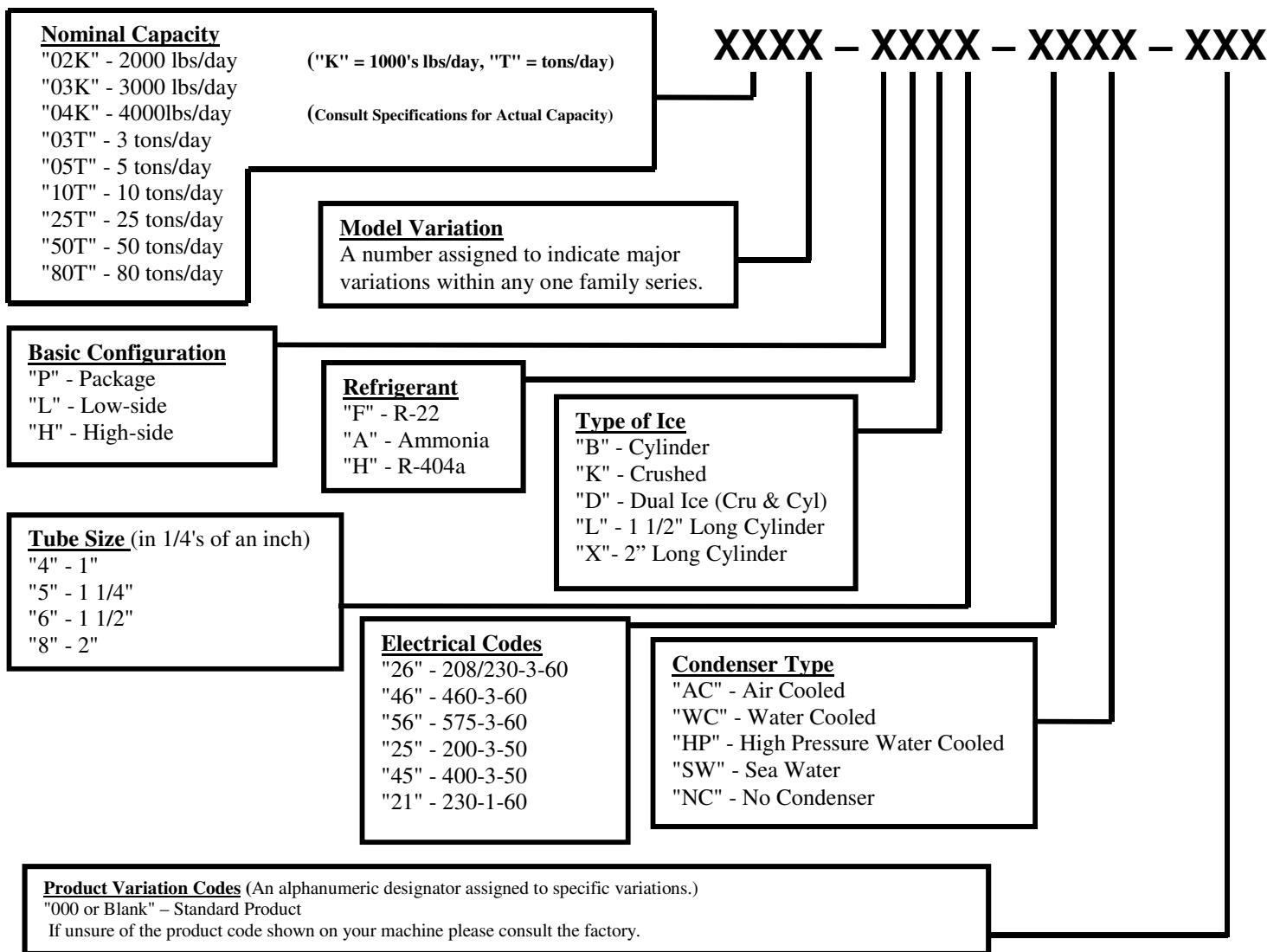
**Machine Room** The machine must be located inside a suitable building and must not be subjected to ambient temperatures below 50°F (10°C) or above 110°F (43.3°C). Heat from other sources (sunlight, furnaces, condenser, etc.) and unusual air currents may affect the operation of the machine and should be avoided. The electrical components of the Tube-Ice<sup>®</sup> machine are rated NEMA 1. Therefore, the machine should not be located in a hazardous area or sprayed with water. The machine should be installed on a drainable condensate drip pan or in an area where water will not stand but will readily drain away from the machine. See Space Diagram for clearances and utility connections, FIGURES 3-4A,3-4B and 3-5.

RECEIPT OF YOUR TUBE-ICE MACHINE

**Storage (prior to installation or start-up)** The machine must not be stored or installed in an area that may reach temperatures 115°F (46.1°C) or above.

<b>! CAUTION !</b>
<b>This equipment contains HCFC-22 or HFC-404a refrigerant under pressure. Do not store in an area exposed to temperatures above 115°F (46°C) or in direct sun at temperatures above 105°F (40°C).</b>
<b>! CAUTION !</b>

The machine nameplate is located on the front of the control panel. The model number and machine description are located in the top left hand corner. The following figure can be used to verify that the correct model has been received.



**Figure 2-1  
Vogt Model Nomenclature**

### 3. Installing Your Tube-Ice<sup>®</sup> Machine

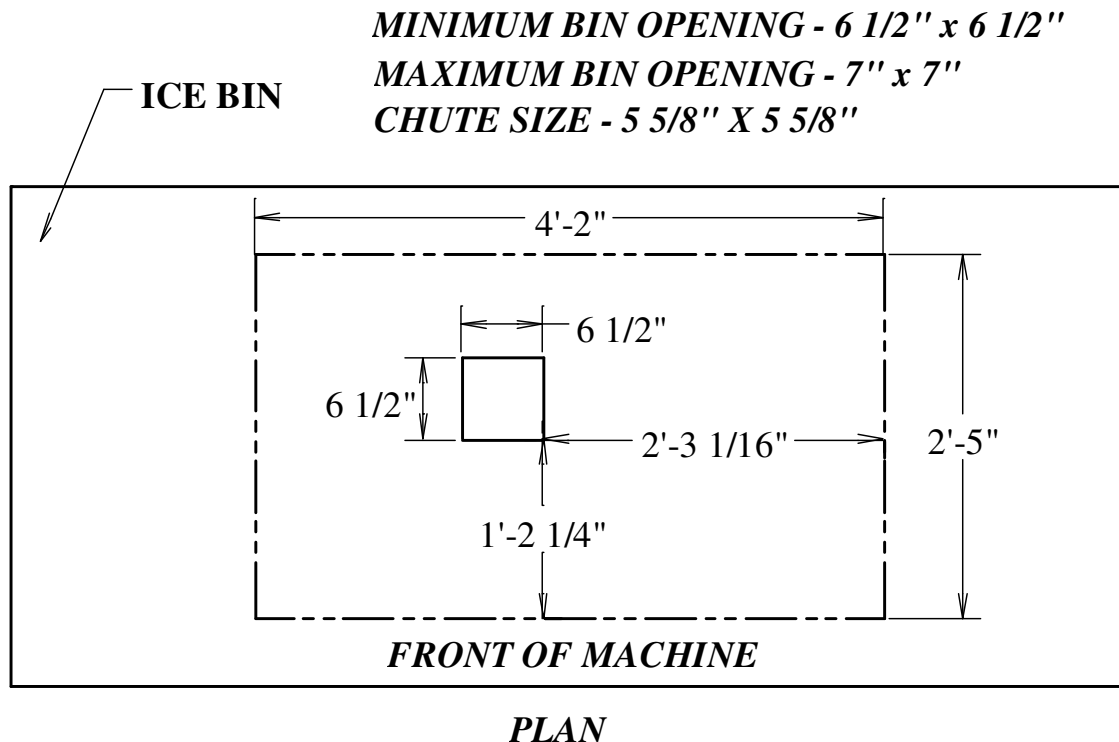
<b>! WARNING !</b>
<b>Only service personnel experienced and certified in refrigeration and qualified to work with high voltage electrical equipment should be allowed to install or work on this Tube-Ice<sup>®</sup> machine.</b>
<b>! WARNING !</b>

#### **Important Notice.**

To activate the machine warranty, the Product Registration Form **MUST** be completed and returned to the factory promptly after the official start-up. Product Registration Form is located in the Owners Packet or can be found online at [www.vogtice.com/registration.htm](http://www.vogtice.com/registration.htm).

**Bin Installation** Set the bin on solid, level footing. Inside the bin you will find the four legs. Screw these legs to the bottom of the bin. You can make MINOR leveling adjustments by using these legs as leveling screws, as outlined in the manufacturer's instructions.

**Setting the ice machine on the ice bin** Once the ice storage bin is level, the Tube-Ice<sup>®</sup> machine can be elevated and placed on the bin top. Using the dimensions in FIGURE 3-1 below, mark the machine footprint on the bin top by measuring over from the ice chute opening.

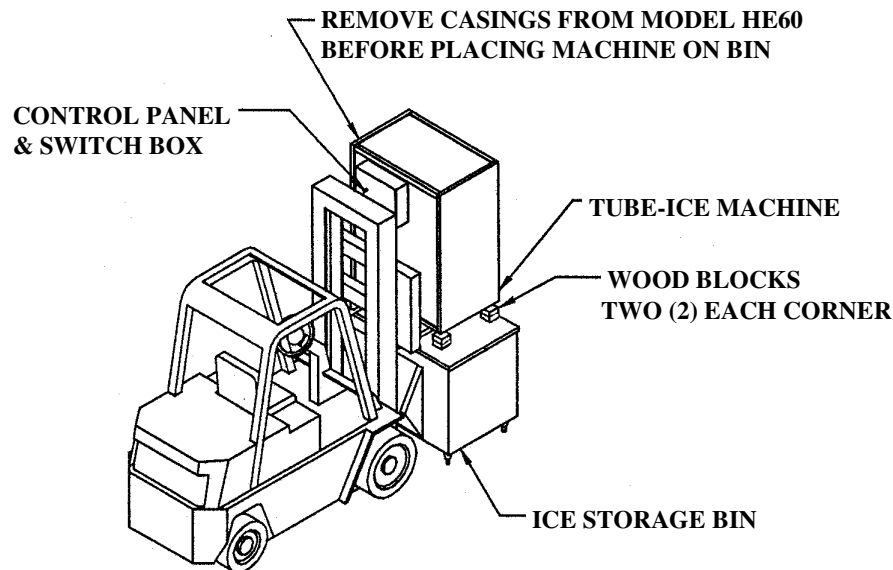


**FIGURE 3-1**  
**Ice Chute Location/Machine Footprint**

## INSTALLING YOUR TUBE-ICE® MACHINE

FIGURES 3-2 & 3-3 illustrate two methods of lifting & setting Tube-Ice® machine on an ice storage bin.

<b>! CAUTION !</b>
<b>The approximate weight of the machine is 2000 pounds. Always use equipment with adequate load-carrying capacity.</b>
<b>! CAUTION !</b>



**FIGURE 3-2**  
**Forklift-&-Blocks Method**

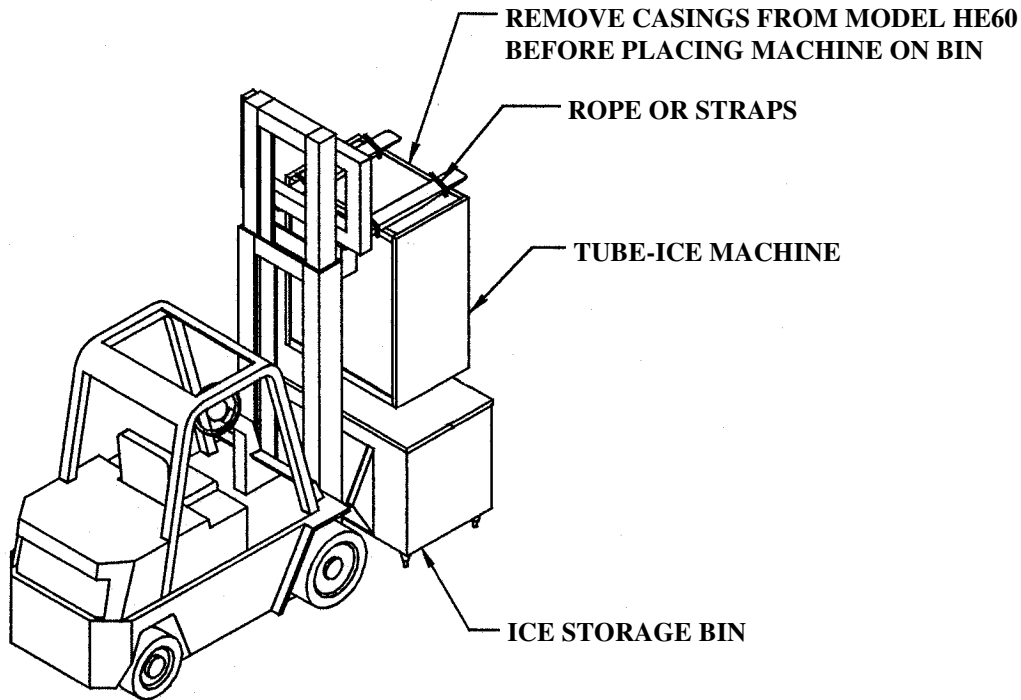
You need:

- ✦ forklift truck with adequate load and height capacities
- ✦ (8) 2X4 wood blocks 8 in. long
- ✦ (2) wooden 2X4's measuring 3-ft. long
- ✦ pry bar

- Step 1. Position Tube-Ice® machine on forks.
- Step 2. Stack wood blocks in each corner of the drip pan on top of the ice storage bin.
- Step 3. Lift and set Tube-Ice® machine on wood blocks.
- Step 4. Remove forklift.
- Step 5. Stack 3-ft. long 2X4's beside drip pan, overlapping front and back of bin.
- Step 6. Using a pry bar with fulcrum on 2X4's, raise side of machine enough to remove TOP wood blocks.

<b>! CAUTION !</b>
<b>Do not remove top AND bottom blocks at the same time.</b>
<b>! CAUTION !</b>

- Step 7. Repeat steps 5 and 6 on other side.
- Step 8. With machine sitting on one (1) block under each corner, repeat steps 5, 6, and 7 remove remaining blocks. Drip pan flanges may bend slightly.
- Step 9. Straighten bent drip pan flanges.
- Step 10. Check alignment of ice chute to bin opening.



**FIGURE 3-3**  
**Forklift-&-Rope or Lifting Straps Method**

You need:

- ✦ extra head room
- ✦ forklift with adequate load and height capacities
- ✦ 1/2" rope or four lifting straps to bind forks to top angles

Step 1. Remove front, rear, and top access panels.

Step 2. Position fork truck so that forks are resting flat on top angles of Tube-Ice<sup>®</sup> machine.

Step 3. Use the rope or straps to securely bind forks to the top angles.

**! CAUTION !**

**Be sure the bin is level and is set in its proper location.  
See the space diagram, FIGURE 6.**

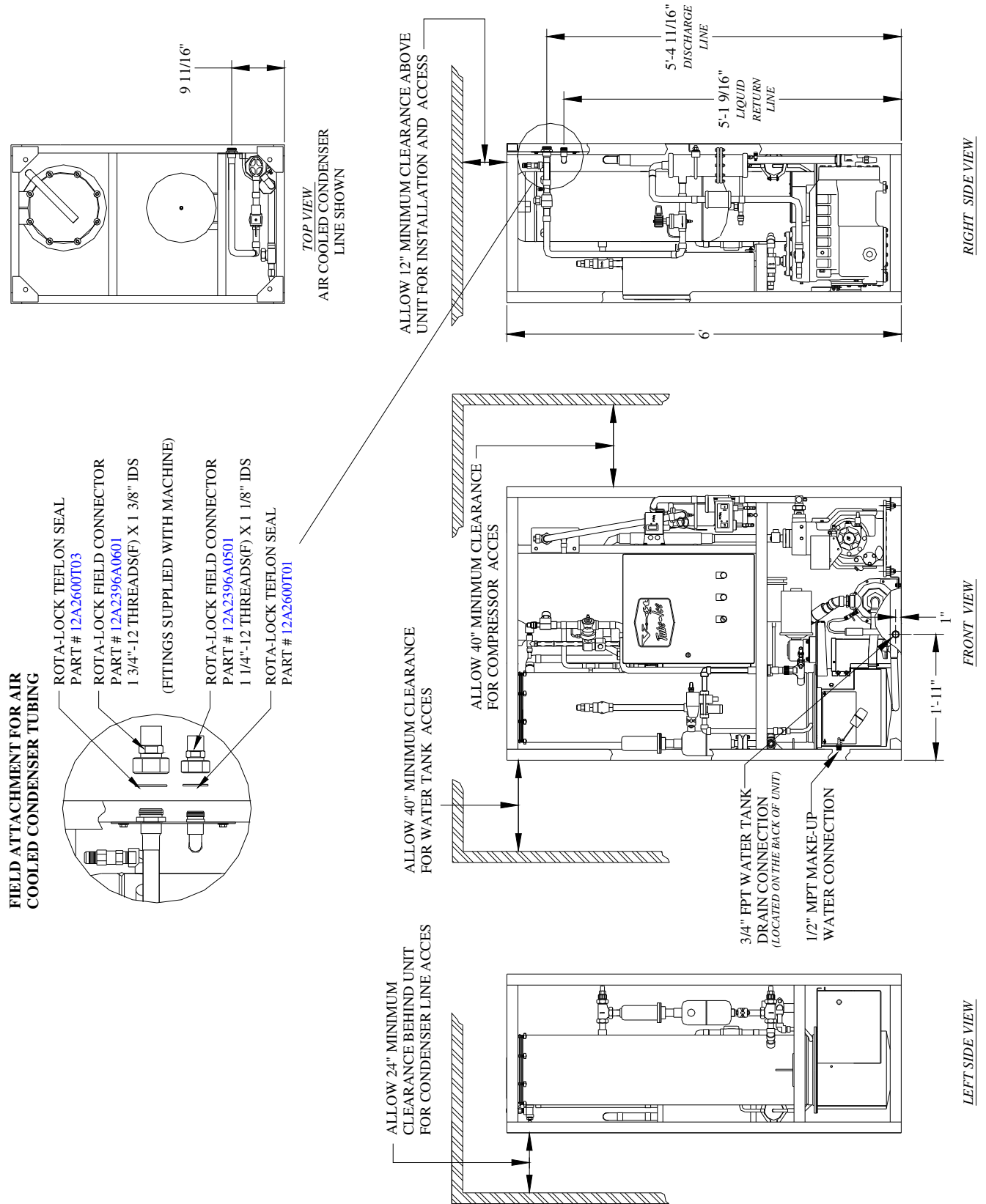
**! CAUTION !**

Step 4. Lift Tube-Ice<sup>®</sup> machine and set into drip pan of bin.

Step 5. Remove rope or straps and fork truck.

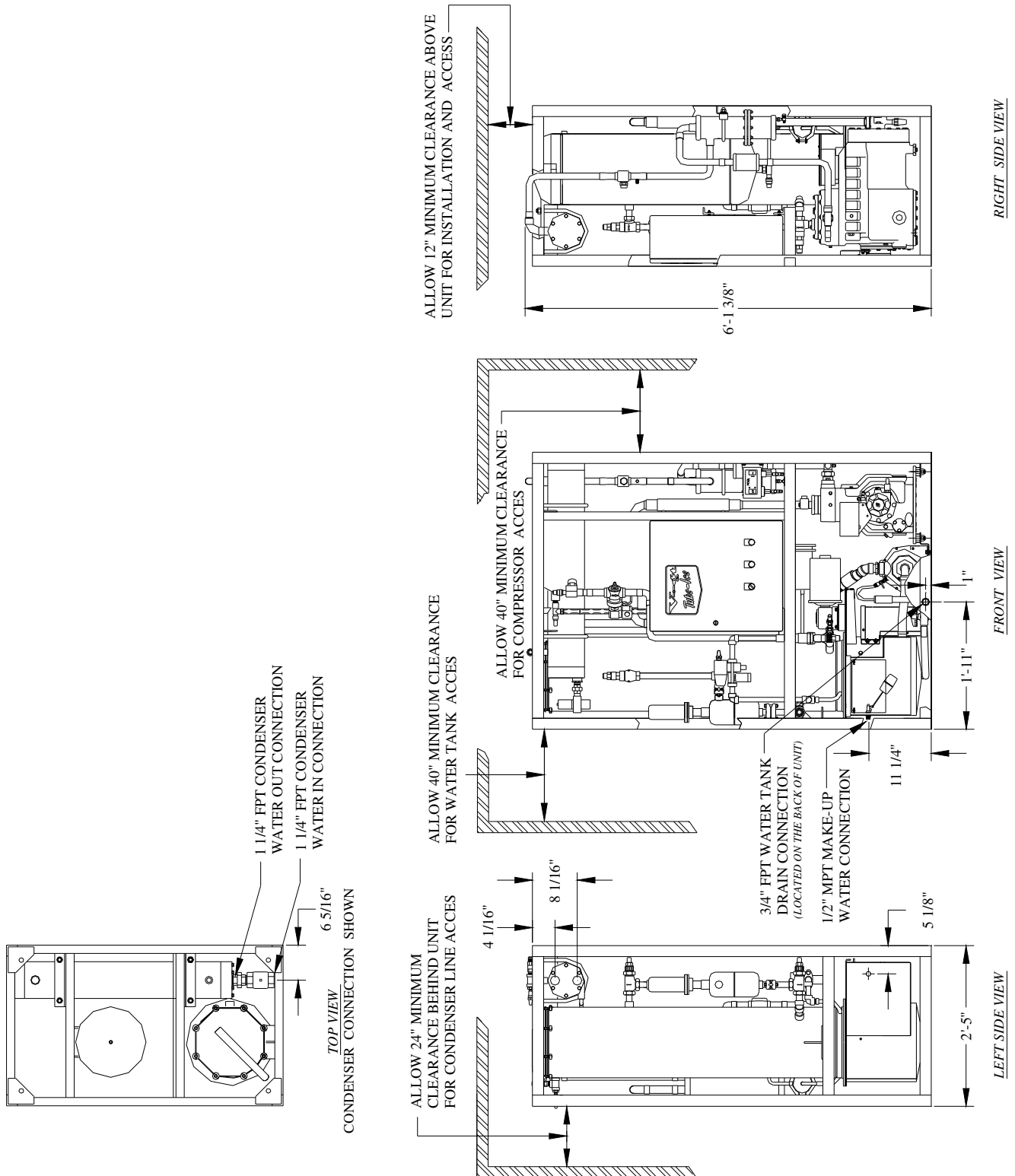
Step 6. Check alignment of ice chute to bin opening.

INSTALLING YOUR TUBE-ICE® MACHINE



**FIGURE 3-4A**  
Connections and Space Diagram (Air Cooled Machine)

INSTALLING YOUR TUBE-ICE<sup>®</sup> MACHINE



**FIGURE 3-4B**  
Connections and Space Diagram (Water Cooled Machine)

## INSTALLING YOUR TUBE-ICE® MACHINE

**Piping and Drain Connections**

Figure 3-4A (Air Cooled) and 3-4B (Water Cooled) show locations and sizes for all connections.

<b>! CAUTION !</b>
<b>External shut-off valves must be provided in the water inlet lines. The minimum inlet water pressure for satisfactory operation of the machine is 30 psig. The maximum allowable pressure is 100 psig.</b>
<b>! CAUTION !</b>

Make-up Water In	Water Tank Drain*	Condenser Water In	Condenser Water Out*
1/2" MPT	3/4" FPT	1 1/4" FPT	1 1/4" FPT

**TABLE 3-1  
Water Supply and Drain Sizes**

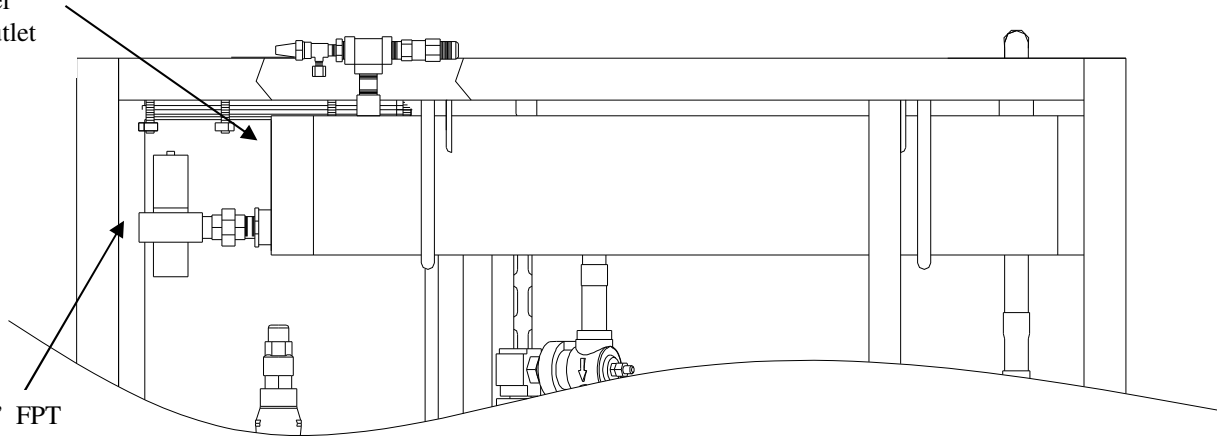
- The condenser water outlet and water tank drain connections must be extended **separately** to an open drain or sump, arranged for visible discharge. **Do not trap the water tank drain line**, as this will interfere with the operation of the automatic blowdown system. A 20 mesh strainer, supplied with the machine, should be installed in the supply line to the condenser.

<b>! CAUTION !</b>
<b>These lines must NOT be connected into a pressure tight common header due to the possibility that warm condenser water may back up into the water tank. The condenser water outlet MUST be piped separately to the drain.</b>
<b>! CAUTION !</b>

## Water-Cooled Connections

Connect water supply to the water regulator valve on condenser water inlet connection (bottom connection on condenser). Connect the condenser water out line to the top connection on the condenser.

1 1/4" FPT  
Condenser  
Water Outlet



1 1/4" FPT  
Condenser  
Water Inlet

**FIGURE 3-5**  
**Water Cooled Condenser Connections**

## Cooling Tower.

**For water cooled machines only.** When selecting a cooling tower, careful attention must be given to operating wet bulb conditions. It is advisable to check with your local cooling tower distributor for their recommendations based on actual operating conditions in your area. An average wet-bulb of 78°F is typical in the U.S. but many localities have design wet-bulbs as low as 72°F or as high as 82°F.

The cooling tower water pump must be capable of delivering the required volume of water through the condenser. Due to cooling tower location and pressure drop through water lines and water regulating valves, the pump must be sized for each installation. Refer to TABLE 11-1 for condenser water requirements. The water piping for the cooling tower and the installation of the pump must be in accordance with the manufacturer's instructions.

Proper water treatment for the prevention of mineral and foreign matter accumulation in the condenser or cooling tower is recommended. A water analysis should be obtained to determine the proper chemicals to use.

INSTALLING YOUR TUBE-ICE<sup>®</sup> MACHINE

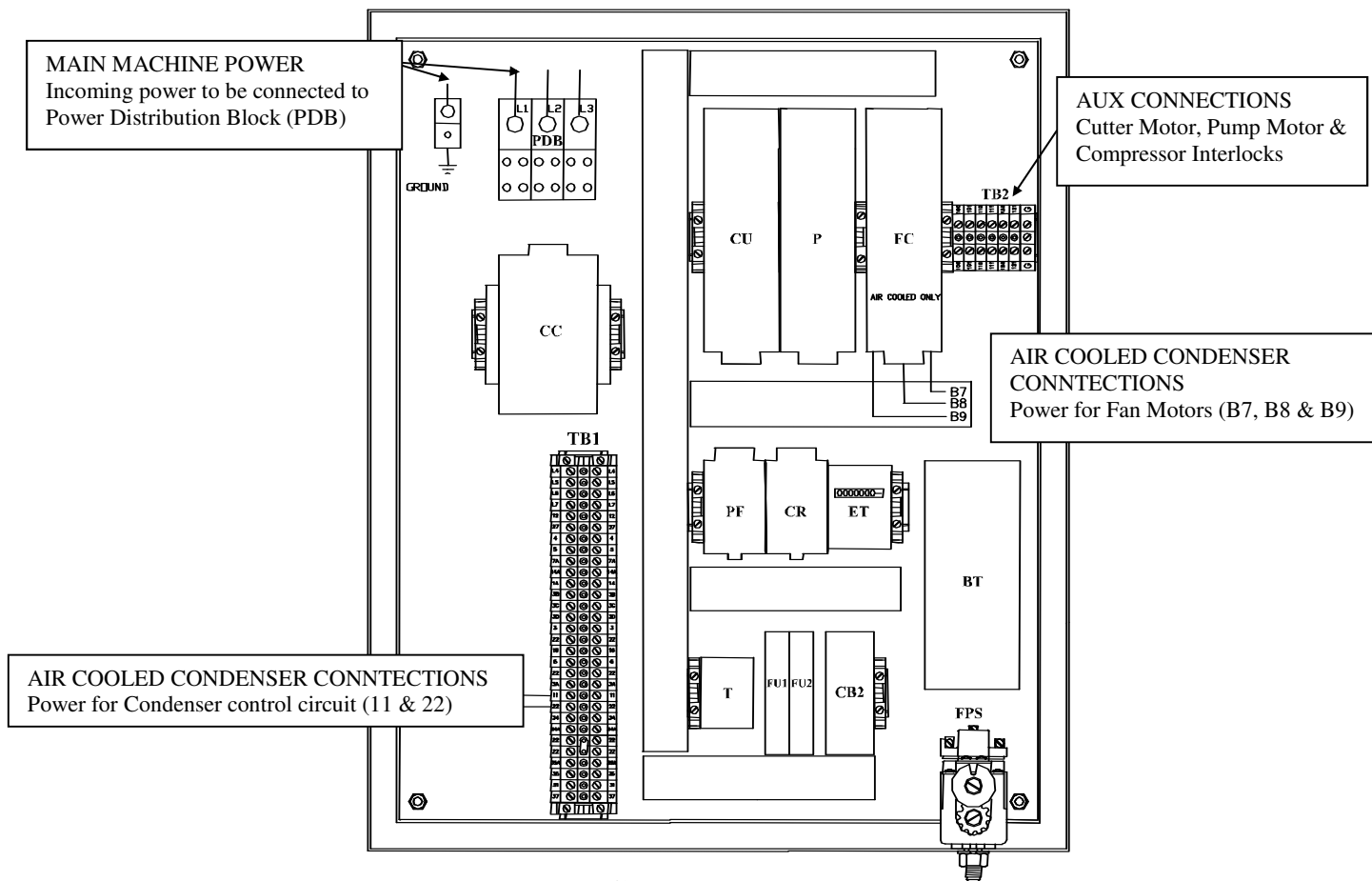
**Wiring and Electrical Connection**

**! WARNING !**

**Only service personnel experienced in refrigeration and qualified to work with high voltage electrical equipment should be allowed to install or work on the Tube-Ice<sup>®</sup> machine.**

**! WARNING !**

Refer to TABLE 3-2 below to properly size wiring connections. A fused disconnect must be provided near the Tube-Ice<sup>®</sup> machine. Connect 3 phase power, L1, L2, L3 to the power distribution block (PDB) for operation of the Tube-Ice<sup>®</sup> machine and its controls. Rotation checking of cutter motor and water pump is required (see following section). Also, if one leg of the 3 phase power is higher or lower (“Wild”), then it should be connected to terminal #L2. Connect the “Ground” wire to the “Ground” lug provided.



**FIGURE 3-6  
Control Panel Power Connections**

Standard Voltages	Water Cooled			Air Cooled		
	F.L.A.	Min. Ampacity	Max. Fuse	F.L.A.	Min. Ampacity	Max. Fuse
208/230, 3ph, 60 Hz	48.3	58.6	100	54.3	64.6	110
460, 3ph, 60 Hz	23.7	28.7	50	26.4	31.4	55
200, 3ph, 50 Hz	50.9	61.8	110	57.5	68.4	115
400, 3ph, 50 Hz	24.2	30.4	55	27.2	32.2	55

**TABLE 3-2  
Electrical Specifications**

## Phase Check

<b>! CAUTION !</b>
<b>DO NOT attempt to start machine without priming pump and insuring proper rotation of both cutter and pump. Refer to FIGURE 3-4A &amp; 3-4B (space diagram) for connection locations.</b>
<b>! CAUTION !</b>

Cutter and pump motor rotation are factory synchronized but **must** be checked at installation. For ice production, the cutter disc, as viewed at the ice discharge opening should turn from left to right (crushed rotation should be from right to left). The pump rotation should match the marking on the pump housing. The pump will need to be primed by starting the machine in the clean mode and allowing it to run for several minutes. To change direction of rotation for both, cutter and pump, disconnect power and reverse L1 and L3 (incoming power wires) at the compressor motor contactor.

**Voltage Unbalance** Voltage unbalance can cause motors to overheat and fail.

The maximum voltage unbalance between any two legs should be no greater than 2%.

**Example: Supply Voltage = 230-3-60**

<b>Voltage Readings:</b>	AB = 220 Volts	<b>Average = (220 + 225 + 227)/3 = 224 Volts</b>
	BC = 225 Volts	
	AC = 227 Volts	

(AB) 224-220 = 4 Volts (Highest Deviation)

(BC) 225-224 = 1 Volts

(AC) 227-224 = 3 Volts

**% Voltage Unbalance = 100 x (4/224) = 1.78% "Acceptable"**

**Important:** If the supply voltage phase unbalance is more the 2%, contact your local electric utility company.

**Current Unbalance** Voltage unbalance will cause a current unbalance, but a current unbalance does not necessarily mean that a voltage unbalance exists. A loose terminal connection or a buildup of dirt or carbon on one set of contacts would cause a higher resistance on that leg than on the other two legs. Current follows the path of least resistance, therefore if terminal connection L1 is loose or dirty, L2 and/or L3 will have higher current. Higher current causes more heat to be generated in the motor windings.

The maximum acceptable current unbalance is 10%.

**Example:**

<b>Current Readings:</b>	L1 = 96 Amps	<b>Average = (96 + 91 + 98)/3 = 95Amps</b>
	L2 = 91 Amps	
	L3 = 98 Amps	

(L1) 96-95 = 1 Amps

(L2) 95-91 = 4 Amps (Highest Deviation)

(L3) 98-95 = 3 Amps

**% Current Unbalance = 100 x (4/95) = 4.2% "Acceptable"**

## INSTALLING YOUR TUBE-ICE® MACHINE

**Air-Cooled Condenser Installation Instructions**

<b>! WARNING !</b>
<b>These installation guidelines must be followed to obtain reliable operation from air cooled ice machines. IF THESE GUIDELINES ARE NOT FOLLOWED THE COMPRESSOR WARRANTY WILL NOT BE HONORED.</b>
<b>! WARNING !</b>

1. Use only Vogt approved condensers. Any exceptions to this policy must be obtained in writing from Vogt prior to installation and operation of the ice machine.
2. Outdoor condensers **must** be installed with vertical air flow. Indoor condensers used for heat recovery may be installed with either horizontal or vertical air flow.  
NOTE: Condenser must be ordered for horizontal air flow.
3. The condenser **must** be mounted above the ice machine.
4. Horizontal runs in the liquid return line should slope 1/4" per foot with liquid refrigerant draining freely in the direction of normal operating flow (back to the ice machine) with no traps in the liquid line.
5. Horizontal runs in the discharge line should slope 1/4" per foot in the normal direction of flow (away from the ice machine).
6. Traps must be installed in discharge lines at the base of all vertical risers. There should be no intentional traps in liquid lines. Trap volume should be kept to a minimum. Long vertical rises should have traps every 20 feet. Typical details are shown in FIGURE 3-9.
7. Flooding head pressure controls such as Alco Headmaster are not to be used since they cause excessive subcooling of the returned liquid refrigerant and interfere with reliable ice harvest.
8. The discharge and liquid lines must be insulated with 1/2" thick Armaflex insulation or equal.
9. Use only ACR grade copper pipe, Type L. Recommended line sizes are shown in TABLE 3-3.
10. For field attachment instructions, see FIGURE 3-4 A.
11. Distance between ice machine and condenser must not exceed 150 equivalent feet. Refer to Condenser Equivalent Line Size worksheet (see TABLE 3-4 ).
12. Condensers must be provided with a cold weather valve kit per FIGURE 3-8. These valves allow one-half of the condenser to be disabled in cold weather. Running the ice machine with one-half of the condenser in cold weather makes it easier to maintain minimum necessary condensing pressure particularly in windy conditions.
13. Condensers with multiple fans must be provided with a thermostat (see FIGURE 3-10) to turn off unneeded fans in cold weather. Turning off unneeded fans reduces on-off cycling of the fan(s) and allows for a steadier condensing pressure and more consistent warm gas for ice harvesting.
14. When extreme cold conditions are expected or encountered (temperatures below 0°F and wind greater than 15 MPH), it may be necessary to install a protective enclosure around the condenser. Apparatuses such as louvers may also be used for varying conditions. Contact the factory for suggestions.

15. After installation, the field installed lines are to be evacuated to a vacuum of 500 microns or less and held for at least one hour. After the vacuum pump is removed, vacuum should hold at 500 microns or less for at least 5 minutes.
16. The machine is shipped with a full operating charge of refrigerant sufficient to fill the condenser and connecting lines. If the condenser piping is longer than 50 feet (one way), additional R-22 or R-404a may need to be added to retain enough refrigerant in the receiver for thawing purposes (see table. Refer to the operating level mark on the receiver and charge accordingly. Each 1” of liquid level in the receiver equals approximately 5.5 pounds of R-22 or R-404a.

<b>Liquid Line Size</b>	<b>75 ft.</b>	<b>100 ft.</b>	<b>125 ft.</b>	<b>150 ft.</b>
1/2”	none	None	None	2
5/8”	none	2	4	6
7/8”	none	4	8	12
1-1/8”	none	6	12	18

**TABLE 3-3**  
**Pounds of R-22 / 404A to Add vs. Liquid Line Length**

17. All piping must be done in accordance with applicable local and national codes. Such codes may include “The Safety Code For Mechanical Refrigeration” (ANSI B9.1) and “The Code For Refrigerant Piping” (ANSI B31.5).
18. The following installation guidelines are strongly suggested. While they do not affect the machine warranty, they may be required for safe operation and to comply with all applicable electrical and mechanical codes:
- Local electrical code must be checked for wiring method.
  - The installer must provide a disconnect switch(s) adjacent to the condenser.
  - Electrical connections between the condenser and the Tube-Ice<sup>®</sup> machine require minimum 12 ga. wire.
  - All electrical fittings and components exposed to the weather must be suitable for outdoor installation.

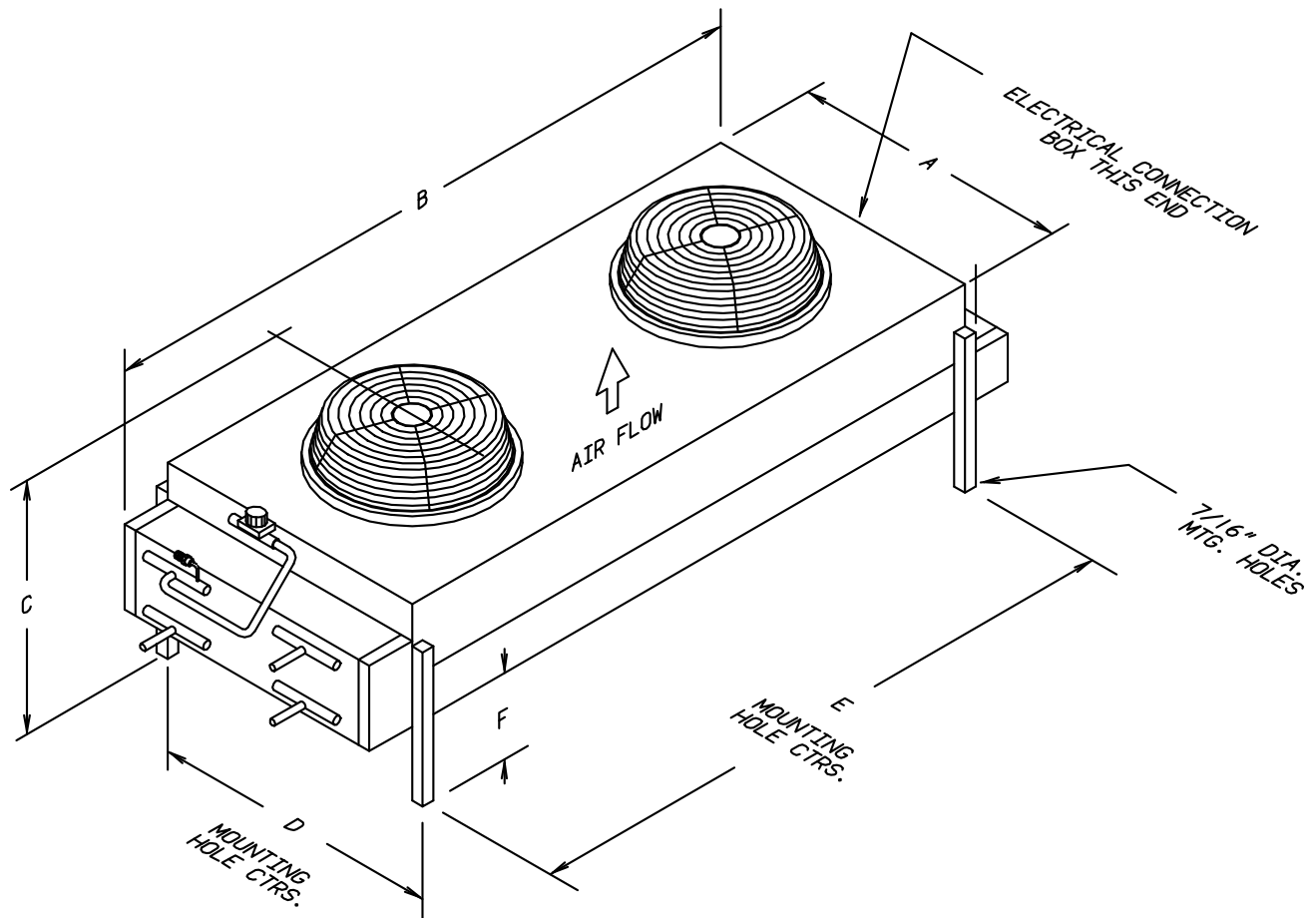
The design total heat rejection for each Tube-Ice<sup>®</sup> machine, the recommended air-cooled condenser, and condenser physical and electrical data are shown on the next page. Specified energy efficiency ratings of the ice machines are based on use of the recommended condenser and approved piping practices.

Recommended condensers provide the indicated total heat rejection at 90°F ambient, 100°F condensing. Vogt Ice, LLC is not responsible for head pressure problems if other than the recommended condensers are used. For continuous operation at ambient temperature above 105°F, consult the factory about using a larger condenser.

## INSTALLING YOUR TUBE-ICE® MACHINE

Ice Machine Model	03TA (Standard)	03TA (High Ambient)
Electrical Frequency, Hz.	60/50	60/50
Recommended Condenser	BNHS02A011	BNHS02A011(12)
Total Heat Rejection (BTU/hr)	157,500 / 144,900	172,500 / 159,700
Fans:		
Number		2
HP, Each		1 1/2
Total CFM		20,500
Full Load Amps (FLA):		
3 ph., 208/230V, 60 hz.		14.0
3 ph., 460V, 60 hz.		7.0
3 ph., 200V, 50 hz.		14.0
3 ph., 380V, 50 hz.		7.0
Weight, lbs.:		
Net	580	585
Shipping	760	765
Operating (Maximum flooded) R-404a	610	615
Condenser Dimensions, inches (See Fig. 3-7)		
A (Width)		45.46"
B (Length)		127"
C (Height)		49.15"
D (Leg centerline)		38"
E (Leg centerline)		106.15"
F (Clearance below)		20.5"
Recommended Line Sizes, OD		
Liquid		
All lengths and orientations		7/8"
Discharge Gas		
Vertical Up, all lengths		1 1/8"
Horiz. or Down, < 75 ft.		1 1/8"
Horiz. or Down > 75 ft.		1 3/8"
Connections at Condenser:		
Liquid (ODV)		1 1/8"
Discharge Gas (ODV)		1 3/8"
Connections at Ice Machine:		
Liquid (ODV)		1 1/8"
Discharge Gas (ODV)		1 1/8"

**TABLE 3-4**  
**Air-Cooled Condenser Data**

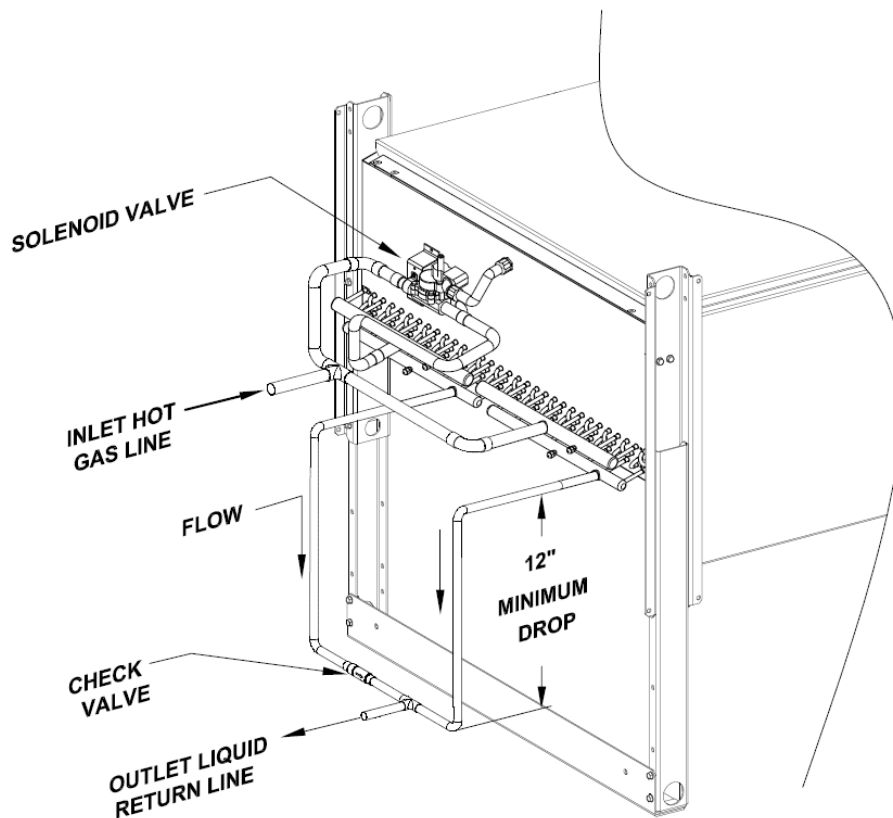
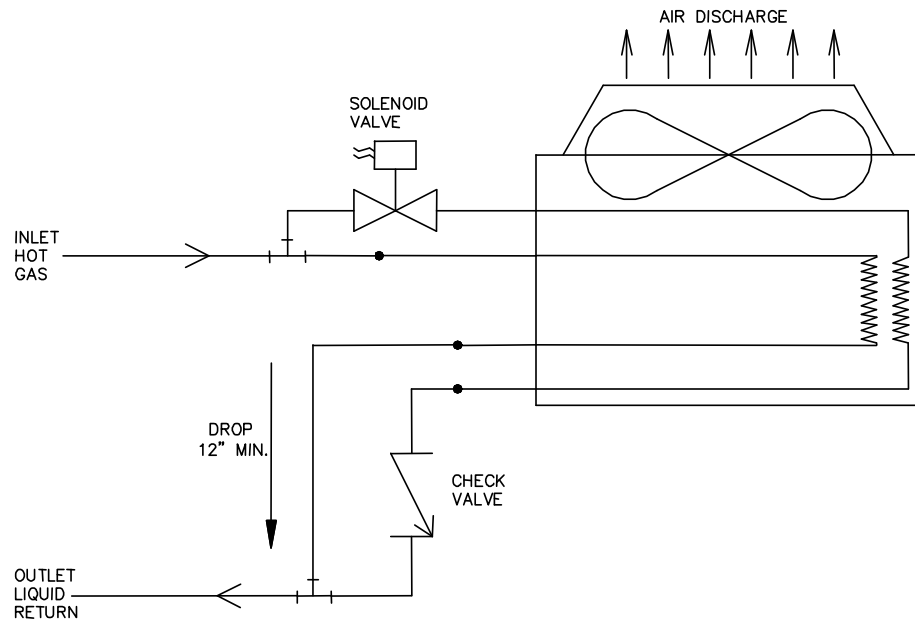
INSTALLING YOUR TUBE-ICE<sup>®</sup> MACHINE

**FIGURE 3-7**  
**Condenser Dimensions**

Machine	Bohn Part #	Vogt Part #	Coil Split
P112 (Standard)	BNHS02A011	<a href="#">12A2115B07</a>	50/50
P112 (High Ambient)	BNHS02A011(12)	<a href="#">12A2115B08</a>	50/50

Note: Condensers listed above are 200/208/230V, 50/60hz. 400/460V, 50/60hz available

INSTALLING YOUR TUBE-ICE® MACHINE



**Note:** Liquid return lines are customer supplied. The Check Valve in the return line (labeled “Output Liquid Return Line”) is supplied with the condenser.

**FIGURE 3-8**  
**Condenser Field Piping / 50-50 Coil Split**

**CONDENSER EQUIVALENT LINE SIZE WORKSHEET**

Discharge Gas Line O.D. \_\_\_\_\_

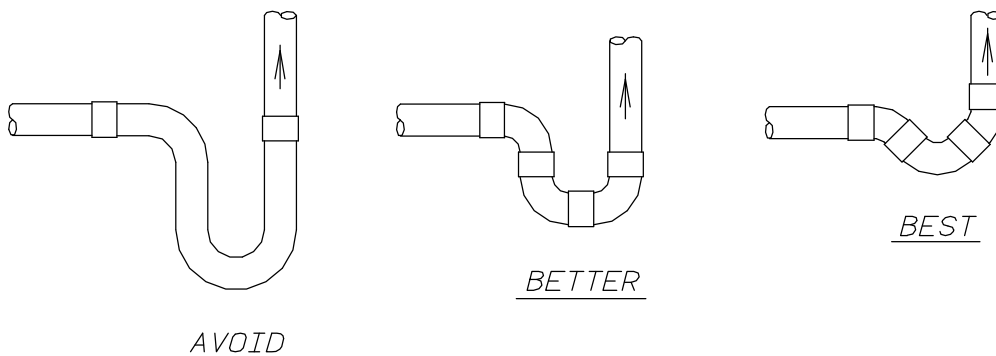
Fitting Type	Number Used	Factor	Total
Globe Valve (open)			
Angle Valve (open)			
90° Elbow			
45° Elbow			
Tee			

Feet of Straight Copper Used	
Total Fitting Factor	
<b><u>Total Equivalent Feet</u></b>	

Copper Tube O.D. Type "L"	5/8"	7/8"	1 1/8"	1 3/8"	1 5/8"	2 1/8"
Globe valve (open)	16	22	28	36	42	57
Angle valve (open)	9	12	15	18	21	28
90° Elbow	2	2	3	4	4	5
45° Elbow	1	1	1.5	2	2	2.5
Tee (90° turn through)	4	5	6	8	9	12
Tee (90° straight through)	1	1.5	2	2.5	2.8	3.5

**TABLE 3-5**  
**Equivalent Feet Due To Friction**

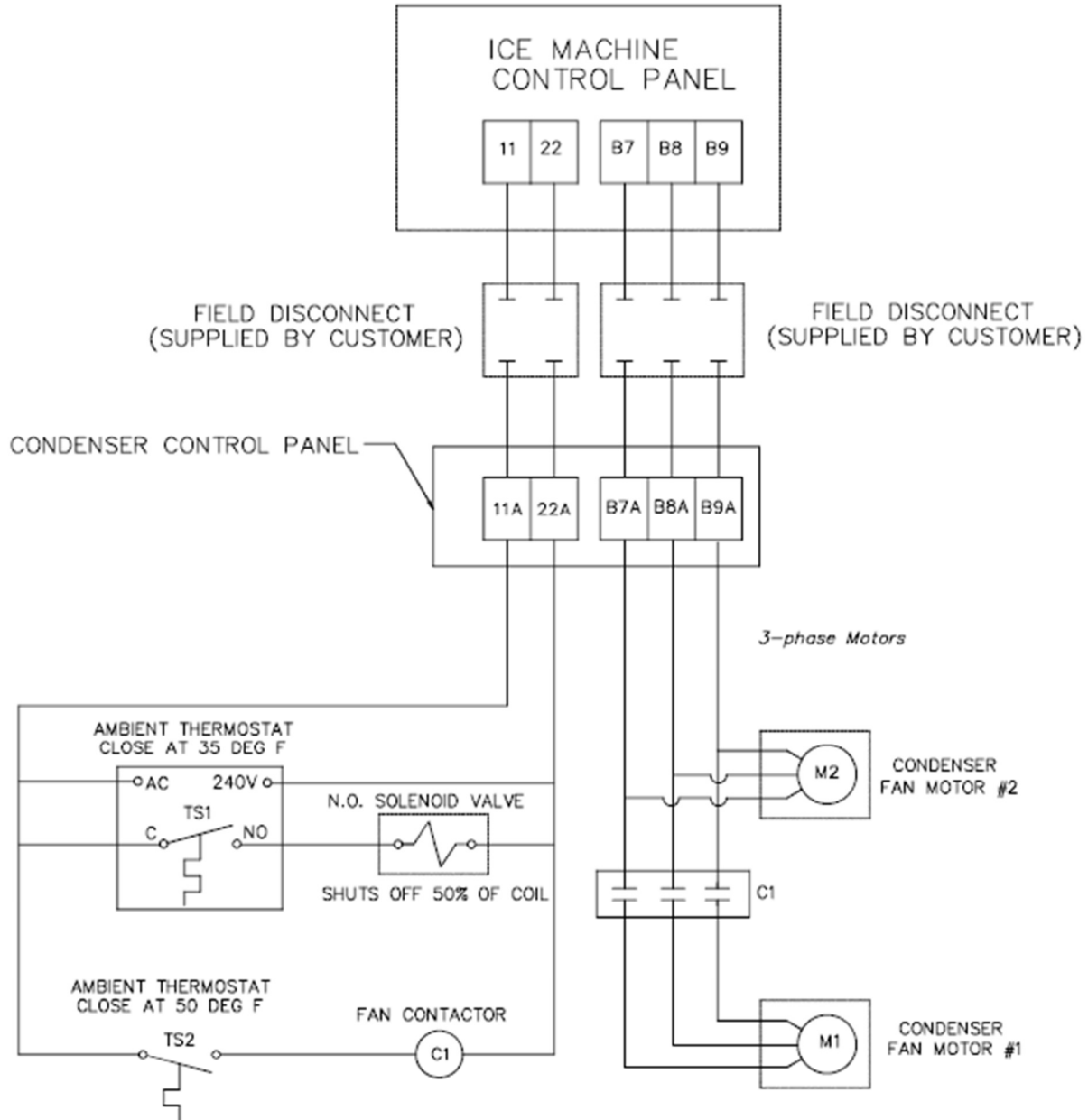


**FIGURE 3-9**  
**Minimum Traps For Discharge Lines**

\*Note: Each recommended line size is based on use of Type "L" copper tubing at a maximum equivalent distance of 150 feet. See TABLE 3-5 for equivalent feet of valves and fittings.

INSTALLING YOUR TUBE-ICE<sup>®</sup> MACHINE

**Air-Cooled Condenser Wiring**



**FIGURE 3-10**  
**Wiring For BOHN BNHS02A011/BNHS02A011(12) with Cold Weather Valve and**  
**Two Fan, 50/50 Condenser Split**

**Air-Cooled Connections** (See FIGURE 3-4 A for connection sizes)

Follow these procedures to make a tight joint:

1. Silver solder or braze condenser tubing ends to the female Rota-lock connectors.
2. Remove dust caps if used, making sure that component plastic seals are intact.
3. Wipe off connector and spud threaded surfaces with a clean cloth to prevent the inclusion of dirt or any foreign material in the system.
4. Connector coupling nut should be screwed onto Rota-lock spud using the proper amount of torque.

<b>Spud Size</b>	<b>Amount of Torque</b>
7/8"	50-60 FT LBS
1 1/8"	80-100 FT LBS
1 3/8"	100-110 FT LBS

**TABLE 3-6**  
**Rota-lock Connector Torque Ratings**

**Pressure Relief Valves** Pressure relief valves are installed on the freezer, receiver and the water cooled condenser. These valves are designed to vent in emergency conditions. This ensures vessel internal pressure does not exceed maximum allowable pressures.

Vent the relief valve outlet to a safe outdoor location in the approved manner away from people and building openings. Vent line piping must have drain line at low point to drain condensate from line per ASME Boiler and Pressure Code, Section VIII, Division 1.

**PRESSURE RELIEF VALVES MUST BE REPLACED AFTER 5 YEARS OF SERVICE.**

**BEFORE REPLACING RELIEF VALVE, REVIEW REQUIREMENTS PER CURRENT LOCAL AND NATIONAL CODE.**

**VALVE REPLACEMENT SHOULD BE MADE BY PROPERLY TRAINED PERSONNEL ONLY.**

**NOTE: IF RELIEF VALVE DISCHARGES, VALVE MUST BE REPLACED AFTER DISCHARGING BECAUSE SETTING OR SEAT TIGHTNESS MAY BE ALTERED.**

**CONTACT VOGT ICE PARTS DEPARTMENT FOR REPLACEMENT VALVES.  
PHONE: 502-635-3000**

INSTALLING YOUR TUBE-ICE® MACHINE

**Ice Bin Thermostat Sensor Installation** Each machine is equipped with an electronic ice bin thermostat. To assure proper protection for the machine, the sensor of the ice bin thermostat must be located so that ice will contact it when the bin is full (See FIGURE 3-11). The distance between the ice chute and the sensor allows space for the machine to make an additional discharge of ice AFTER the ice contacts the probe WITHOUT the ice building up into the discharge opening of the chute.

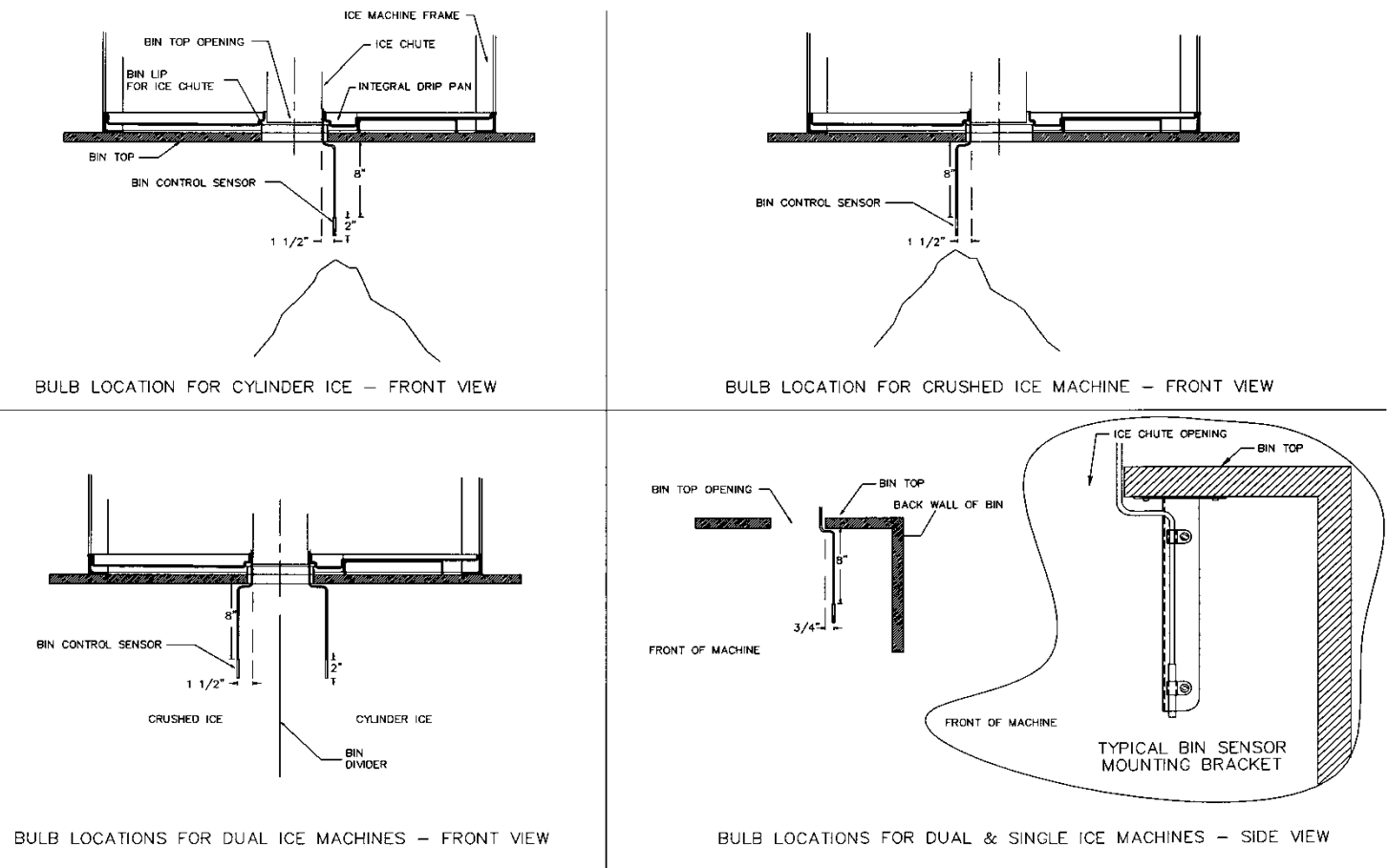
**Note:** The probe should also be mounted on the back side of the bracket, opposite of the front of the bin to reduce the possibility of damage from ice removal equipment.

The control panel is electrically connected so that the bin thermostat will stop the machine only upon the completion of a harvest period.

When both cylinder and crushed ice are produced and separately stored in a divided bin, the control sensor of thermostat BT2 is placed in the crushed ice section of the storage bin (left side) and the control sensor of thermostat BT1 is placed in the cylinder ice section (right side of bin).

**Note:** Drip loop not necessary for Electronic Thermostat

MOUNTING BIN CONTROL SENSOR



**FIGURE 3-11**  
**Ice Bin Thermostat Location**

## Programming the Electronic Bin Thermostat

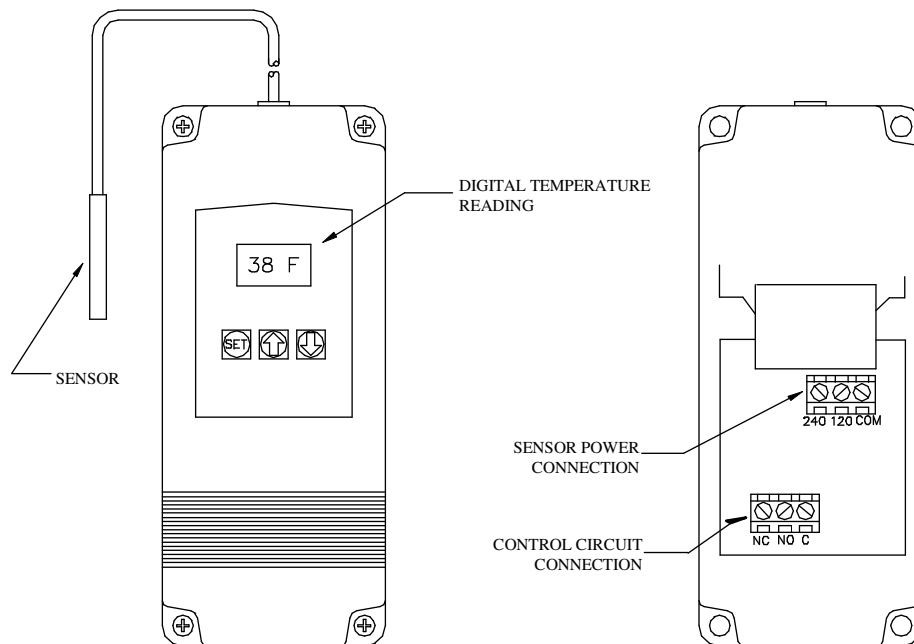
The electronic bin thermostat has an LCD readout that displays the temperature in the bin at the sensor. **The control has been preset and locked out at the factory to shut the machine down at 38°F and to re-start at 40°F.** The control retains the program even if power is cut to the machine. Under special conditions, the settings may need to be changed. The lockout switch is located on the inside of the control. Removal of the four screws on the face of the control will reveal the lock-switch.

Follow the instructions below to reset the switch.

1. Press the “SET” button to enter the sensors setup mode
2. Select between “C” - Celsius and “F” - Fahrenheit  
Use the up ↑ or down ↓ key to select “F”
3. Press the “SET” button to set the Set point (S1 will be blinking)  
Use the up ↑ or down ↓ key to set the temperature at 38°F
4. Press the “SET” button to set the Differential (DIF 1 will be blinking)  
Use the up ↑ or down ↓ key to set the differential at 2°F
5. Select between “C1” - Cooling mode and “H1” - Heating mode  
Use the up ↑ or down ↓ key to select “C1”

Machine will shut off when temperature drops to 38°F and come on when temperature reaches 40°F.

**Note:** The sensor will automatically exit the programming mode if no keys are depressed for a period of thirty seconds. Any settings that have been input to the control will be accepted at that point.



**FIGURE 3-12**  
**Electronic Thermostat**

**Note:** If damaged, the sensor can be replaced without replacing entire unit.

Replacement sensor part #[12A2117G0901](#). Electronic temperature control part #[12A2117G09](#).

Sensor cable can be extended up to 400 feet. For more information, consult Tube-Ice<sup>®</sup> Technical Service Department.

## INSTALLING YOUR TUBE-ICE® MACHINE

**Storing Ice.** When storing ice in a bin, make sure the bin control sensors are mounted in the bin properly. Dual ice machines require a storage bin with a divider and must have two bin controls.

A machine making one type of ice will not have a bin divider and will require only one bin control. If the machine is making cylinder ice, the sensor should be mounted on the right side of the bin. If making crushed ice, the sensor should be mounted on the left side of the bin.

**Ice Bin Capacity.** Crushed or cylinder ice weighs approximately 35 pounds per cubic ft. (35 lb/ft<sup>3</sup>). As ice drops into a bin, it will pile up and slope naturally at about a 45° angle. This natural slope should be taken into account when locating the bin thermostat bulb (or other bin level control) and when calculating the normal bin capacity. If the ice is spread out by hand in the bin for maximum storage capacity, make sure a hazard is not created by allowing ice to back up into the chute and jamming the cutter. Always allow enough room below the chute for at least one harvest (cylinder ice = 62 lbs. / cycle , crushed ice = 48 lbs. / cycle).

If a two-way deflector is installed below the ice chute, care should be taken to make sure it is located directly in the center of the stream of ice as it falls to give even distribution of the ice.

**When ice bin thermostats are NOT used.** With the selector switch set on either “Auto” or “Cyl” ice, the machine will produce cylinder ice only. If the switch is changed to “Cru” while the unit is producing cylinder ice, after the first 5 minutes of a cycle, it will complete the freeze and harvest of cylinder ice before changing to the production of crushed ice. The next cycle will produce crushed ice.

With the switch set on “Cru” the machine will produce crushed ice. If the switch is changed to “Both Auto” or “Cyl” within the first 5 minutes of a cycle, the unit will revert immediately to the production of cylinder ice.

If an alternate bin level control is used, it must be located in a position to stop the machine prior to ice backing up into the ice chute and jamming cutter.

**Single Ice Type.**

**No Divider in bin (cylinder or crushed ice).** With the selector switch on “Ice”, the machine will produce either cylinder or crushed ice. The machine will contain only one freezer pressure switch (FPS) and one bin Control (BC), and two selector switches (SS1 (Ice/Clean) & SS2 (On/Off), the reversing relay (R) is not included. The machine will also be supplied with an ice chute without an ice deflector door assembly.

**Dual Ice Type (crushed and cylinder).**

**Divider in bin (cylinder and crushed ice separately stored).** With the selector switch on “Auto”, the machine will automatically produce cylinder ice until the cylinder-ice bin is filled. This action will open the cylinder ice thermostat switch in the cylinder ice bin and will automatically change the machine over to crushed ice production--provided the crushed bin is not full. When the crushed ice bin is filled, its thermostat switch opens and stops the machine upon completion of the harvest cycle.

With the selector switch set on “Cru”, the machine will produce crushed ice until the bin is filled and the thermostat switch opens. It will then shut down at the completion of the thawing period. If the switch is changed to “Auto” or “Cyl” within five minutes of the machine starting crushed ice freeze, it will not switch immediately to the production of cylinder ice.

The machine will never stop by action of the bin thermostat during any freezing operation. It will always complete the evacuation and discharge of all the ice and completion of a cycle regardless of the causes which open either thermostat switch.

<b>! IMPORTANT !</b>
<b>Be sure to follow the wiring schematic and electrical specification table when incorporating overloads. This is necessary to provide proper protection for the Tube-Ice<sup>®</sup> machine and its component parts.</b>
<b>! IMPORTANT !</b>

**Installation Review: A Checklist.** Make a visual check to be sure these steps have been taken BEFORE continuing.

CHECK: \_\_\_ PRIOR TO OPENING VALVES, check all joints for leaks which may have developed during shipment.  
(NOTE: the machine was shipped with a positive pressure of 20-25 PSIG, verify on the freezer pressure gage.)

CHECK: \_\_\_ All refrigerant piping, water supply and drain connections for conformity to requirements stipulated in this manual and properly connected to inlets and outlets.

CHECK: \_\_\_ Electrical supply for proper size of fuses and for compliance to local and national codes. See the machine nameplate for minimum circuit ampacity and maximum fuse size.

CHECK: \_\_\_ All field installed equipment (augers, conveyors, cooling towers, bin level controls, etc.) for proper installation.

CHECK: \_\_\_ The applicable portion of the warranty registration/start-up report for proper completion.

CHECK: \_\_\_ Cutter gear reducer oil level oil should run out of side pipe plug when removed.

CHECK: \_\_\_ The water distributors at top of freezer to make sure they are all in position

<b>! CAUTION !</b>
<b>The compressor crankcase heater should be energized for a minimum of Two (2) hours before attempting to start the compressor.</b>
<b>! CAUTION !</b>

Blank page

## 4. How Your Tube-Ice<sup>®</sup> Machine Works

**Principle of Operation** For a detailed description of the functions of each control panel component, see Section 6. “Clean/Off/Ice”, “Start” and “Stop” switches located in the control panel of the freezing unit control operation of the machine. Automatic operation can be controlled by an optional ice bin thermostat, which will automatically stop and start the ice maker by the level of the ice in the storage bin (NOTE: See FIGURE 3-11, “Ice Bin Thermostat Location” for instructions on installation of the control sensor of the ice bin thermostat(s)). The type ice produced (cylinder or crushed) is determined by how the machine cutter is set-up (cylinder is standard, crushed or automatic is optional). The control wiring is arranged so that the unit will stop only upon the completion of a thawing period whether by action of the “Clean/Off/Ice” switch in the “Off” position or the ice bin thermostat.

The “Clean/Off/Ice” switch must always be set in the “Ice” position during normal ice-making operation. It is set in the “Clean” position only when the equipment is to be cleaned as outlined in the “Cleaning Procedure” (Section 7) and instructions shown on the water tank cover.

If it should become necessary to instantly stop the machine, push the “Stop” button. To restart the machine, push the “Start” button. The machine will restart in a harvest, to clear out any ice remaining in the freezer, if stopped during a freeze period.

FIGURES 4-1 & 4-2 illustrate the piping diagram of the refrigerant and water circuits of the Tube-Ice<sup>®</sup> machine with numbers for easy reference. Throughout this manual, the numbers you see in parentheses refer to the numbers in this piping schematic.

The freezer (2) is a shell and tube-type vessel. During the freezing period, water is constantly recirculated through the vertical tubes of the freezer by a centrifugal pump (6). Make-up water is maintained by a float valve (12) in the water tank (7). The liquid feed solenoid valve (20), sometimes referred to as the “A” valve, is open and the thawing gas solenoid valve (18), sometimes referred to as the “D” valve, is closed.

Refrigerant gas from the top of the freezer (2) passes through the suction accumulator (88), the heat exchanger (13), and to the compressor (3). Here the cool gas is compressed to a high temperature, high pressure gas which discharges through the oil separator (14) and into the condenser (15). In the condenser, heat is removed and the gas is condensed to a high temperature, high-pressure liquid. The high-pressure liquid goes through the accumulator boil out coil (88) and suction line heat exchanger (13) where it gives up heat to the suction gas for compressor protection. In addition, this liquid is subcooled and carried to the receiver (15R). Liquid refrigerant from the receiver flows through the filter/drier (46), thawing chamber (16), liquid feed solenoid valve (“A” valve) (20) and thermal expansion valve (17) into the freezer. The “A” solenoid is energized when the machine is in freeze cycle. The cold liquid refrigerant enters the freezer where it absorbs heat from the circulating water. Cool gas is pulled out of the freezer at the suction outlet thereby completing the cycle.

The freezing period is completed by action of the freezer pressure switch in the control panel. The water pump (6) is stopped and solenoid valve “A” (20) is closed. The thawing period then begins. Solenoid valve “D” (18) is opened, the cutter motor (5M) is started and the harvest (thaw) timer is activated. Warm gas from the receiver is discharged into the freezer through valve (18), thereby slightly thawing the outer edge of the ice, which drops on the rotating cutter for sizing. Air-cooled machines have a solenoid valve (53), sometimes referred to as the “X” valve, in the compressor

## HOW YOUR TUBE-ICE® MACHINE WORKS

discharge line, and a check valve (101) in the liquid return line to the receiver. These valves prevent the migration of refrigerant to the condenser when the machine is not operating.

**Freeze Period** The Tube-Ice® is frozen inside the stainless steel tubes in the freezer (2) by the direct application of refrigerant to the shell side (outside) of the tubes. The ice is produced from constantly recirculating water during the freeze period. As the ice thickness increases, the freezer suction pressure decreases. At a set pressure, the freezer pressure switch initiates the harvest period.

**Harvest Period** When the freezer pressure switch (56, FPS) contact closes, a control relay (CR) is energized. The “CR” relay stops the water pump and starts the cutter motor. The “A” (liquid line) solenoid valve closes, the “D” (thaw gas) solenoid valve opens and the thaw timer (T) is energized. As the ice releases and drops through the rotating cutter and onto the cutter disc, it is discharged through the side opening of the water tank. The harvest timer (T) is to be set for the time required to discharge all the ice plus 30 seconds longer (usually 2 1/2 minutes).

<b>! CAUTION !</b>
<b>Make sure all the ice clears the freezer with at least 30 seconds to spare before the next freeze period begins. This is to prevent refreezing.</b>
<b>! CAUTION !</b>

Item No.	Description	Item No.	Description
1	Control Panel	32	A/C Condenser Service Connection
2	Freezer	34	Compressor Suction Service Valve
3	Compressor	35	Compressor Discharge Service Valve
4PS	Dual High/Low Pressure Switch	37	Oil Charging/Drain Valve
5M	Cutter Motor	39	Water Tank Drain Valve
5R	Gear Reducer	40	Automatic Water Tank Blowdown
6	Water Pump	41	Condenser Water Regulator (W/C Machines Only)
6A	Water Pump Check Valve	41A	Condenser Pressure Control (A/C Machines Only)
7	Water Tank (includes cutter assembly)	43	Liquid Feed Solenoid Valve Strainer
8	Water Distributing Chamber	46	Filter Drier
12	Make-up Water Float Valve	48	Muffler
13	Heat Exchanger	50	Receiver Safety Valve
14	Oil Separator	51	Freezer Safety Valve
15	Condenser	52	Condenser Safety Valve (W/C Machines Only)
15R	Receiver	53	Cold Weather Solenoid Valve “X” (A/C Machines Only)
16	Thawing Chamber	55	Discharge Line Stop Valve
17	Thermal Expansion Valve	56	Freezer Pressure Switch (Inside Control Panel)
18	Thawing Gas Solenoid Valve (“D” Valve)	58	Liquid Outlet Valve (King Valve)
20	Liquid Feed Solenoid Valve (“A” Valve)	69	Freezer Pressure Stop Valve
23	Condenser Water Inlet (W/C Machines Only)	88	Accumulator/Heat Exchanger
24	Condenser Water Outlet (W/C Machines Only)	90	Thawing Gas Stop Valve
25	Water Tank Drain Connection (3/4” FPT)	91	Receiver Liquid Return Stop Valve
28	Refrigerant Charging Valve	94	Compressor Oil Pressure Safety Control
30	Receiver Gage Glass	101	Check Valve
31	Gage Glass Stop Valve		

**TABLE 4-1**  
**Piping Nomenclature**



HOW YOUR TUBE-ICE® MACHINE WORKS

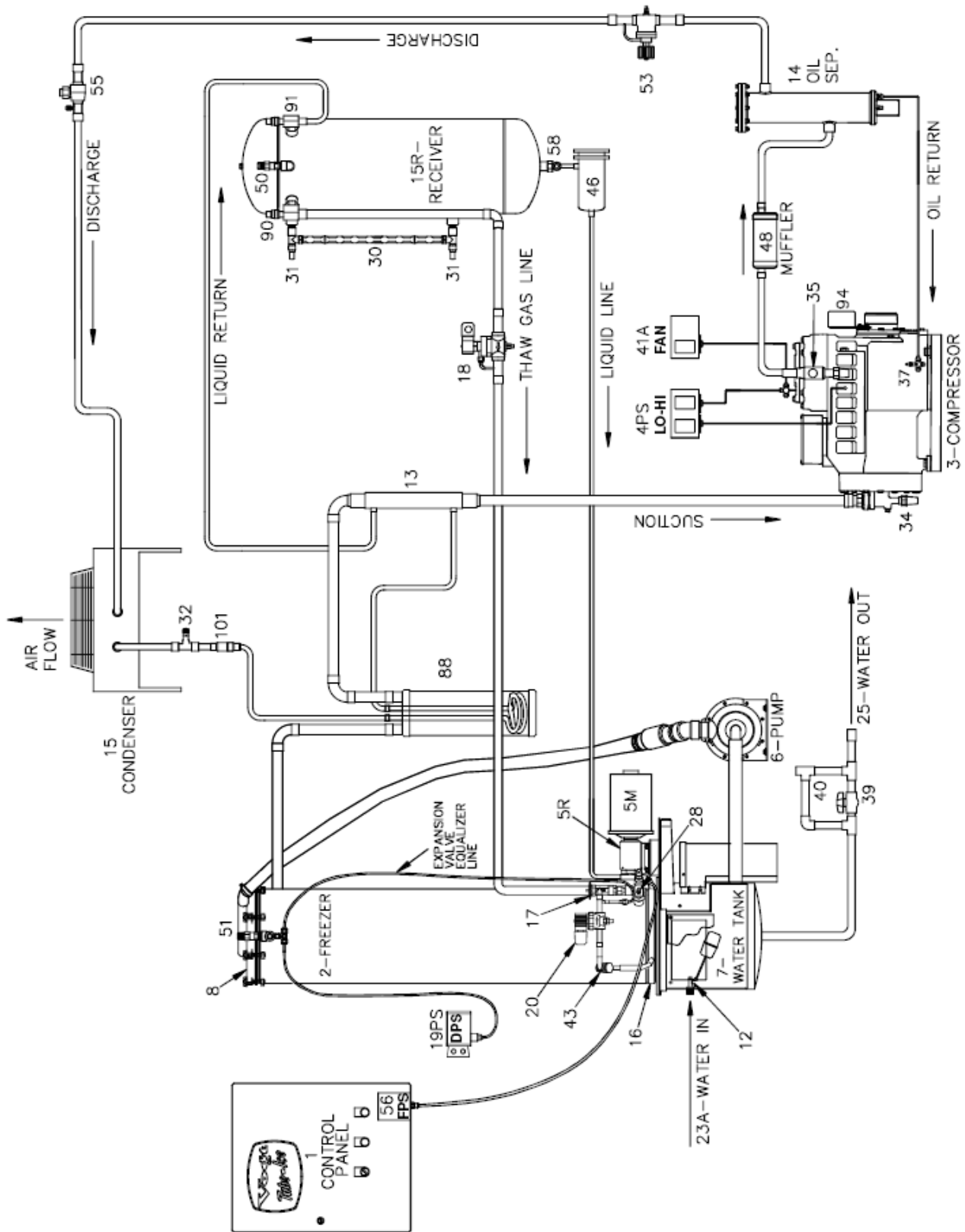


FIGURE 4-2  
Air-Cooled Piping Schematic

## **5. Start-Up and Operation**

**Refrigeration System Review.** The refrigeration system uses R-22 or R-404a refrigerant, a compressor, a refrigerant float switch, a flooded evaporator (freezer), and warm gas defrost. Following the schematic, notice that during the freeze period of the machine's cycle, the compressor discharge gas leaves the compressor and goes to the condenser where it is condensed into liquid by the removal of heat by either air or water passing through the condenser. A reservoir of liquid is accumulated in the receiver and flows as required, passing through the filter/drier, the thawing chamber (a lower separate section of the freezer) and the liquid feed solenoid valve (the "A" valve). The opening of the "A" valve by the float switch during the freeze cycle allows the liquid to be metered by the (17) hand expansion valve. The "A" valve opens and closes in response to the refrigerant level in the freezer. Wet refrigerant floods the evaporator and is in contact with the outside of the ice-making tubes in which water is being circulated. The heat contained in this water passes through the wall of the tubes, lowering the temperature of the water, causing it to freeze and form a long tube of ice that adheres to the inside of each of the freezer tubes. The flowing water keeps the accumulated ice clear by washing separated solids down into the sump area of the water tank.

The wet suction gas leaves the freezer and any remaining liquid droplets are removed by the accumulator and suction line heat exchanger. The dry gas enters the compressor and is compressed then discharged to the condenser completing the cycle.

As the ice is formed in the freezer, the suction pressure steadily reduces until it causes the freezer pressure switch contacts to close, initiating the harvest period.

During the harvest period, the liquid feed solenoid valve ("A" valve) closes and the thawing gas solenoid valve (the "D" valve) is open allowing the warm high pressure gas to enter the freezer. This heat melts a thin film from the outside of the ice, reducing the diameter and letting it fall free from the freezer tubes. This period lasts approximately 2 1/2 minutes.

**Refrigerant Charge.** Included with the machine is the required charge (approximately 135 lbs.) of Refrigerant 22 or 404a, depending on the model, which has been isolated in the receiver (15R). Before shipment of the machine, the compressor service valves (34), (35), and the stop valves in the various lines to the condenser and receiver have been closed. These valves are tagged with instructions that the valves are to be opened prior to start-up of the machine. Before opening these valves, it is advisable to check all joints for leaks that may have developed during shipment. If no leaks are present, a positive pressure should show on the suction and discharge pressure gages.

If it should ever become necessary to add refrigerant to the system, charging valve (28) is provided for this purpose. Through this valve, refrigerant can be added in liquid form. See "Adding Refrigerant." The compressor crankcase heater must be energized for a minimum of two hours prior to starting and running the compressor.

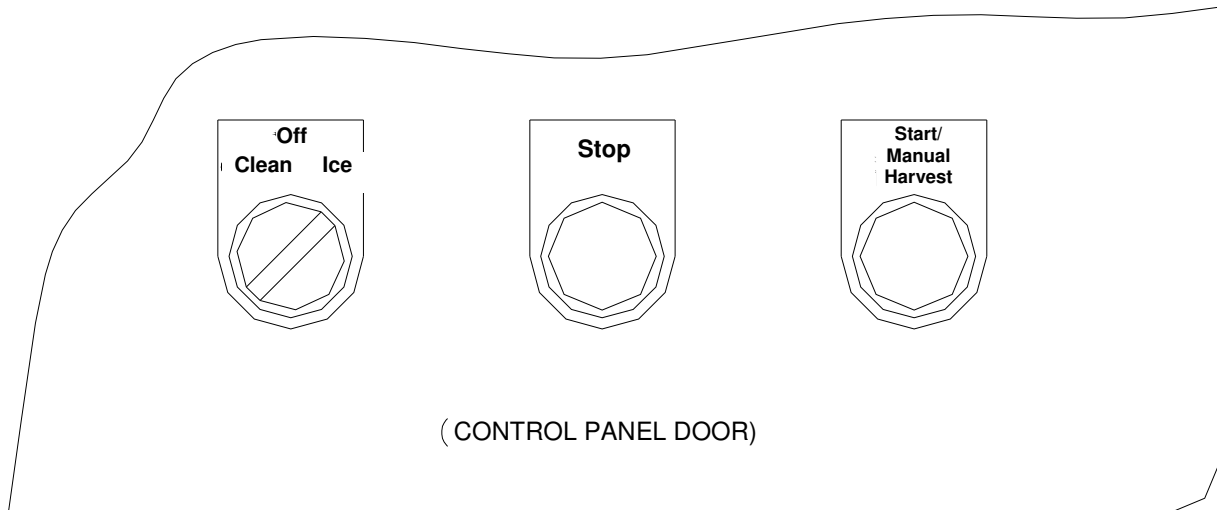
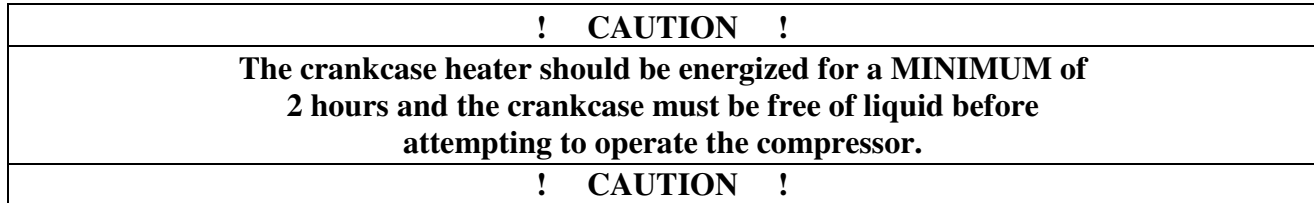
## START-UP AND OPERATION

**Start-up Checklist.** Be sure to complete and return the “Warranty Registration/Start-Up Report” located at the front of the manual.

- \_\_\_\_\_ 1. See that water-inlet and outlet connections are attached properly. The water inlet shutoff valves for the water tank and condenser should be open. The water level in the water pan should be at a height where the make-up water float valve will be closed when the machine is idle.
- \_\_\_\_\_ 2. See that the cutter motor gear reducer is lubricated (see Section 7 “lubrication of the cutter gearbox (5R)” for instructions).
- \_\_\_\_\_ 3. See that compressor crankcase oil level is at proper height of 1/4 to 1/2 of the sight glass.

<b>NOTE</b>
<b>All valves are tagged with instructions.</b>
<b>NOTE</b>

- \_\_\_\_\_ 4. Open compressor service valves (34 and 35), the hand-stop valve (90) in the thawing gas line, the receiver liquid return stop valve (91) in the condenser return line, hand-stop valve (58) in the liquid line, hand-stop valve (69) to the freezer pressure switch and the stop valve (70) in the oil return line. These valves are tagged to indicate that they were closed for shipping purposes. Gage glass valves (31) on the receiver can be opened for liquid level observation but should remain closed for unattended operation.
- \_\_\_\_\_ 5. IMPORTANT! CHECKS TO SEE that all stop valves in the various refrigerant lines are open according to the attached tags.
- \_\_\_\_\_ 6. Immediately after opening all valves, entire machine should be checked for refrigerant leaks with electronic leak detector.
- \_\_\_\_\_ 7. See that “Ice/Off/Clean” Switch (SS) is in the “Ice” position.
- \_\_\_\_\_ 8. Close exterior disconnect switch to energize crankcase heater and check for compliance to nameplate.



**FIGURE 5-1**  
**Bottom Portion of Control Panel**

### **Start-Up Procedure**

Starting the machine in freeze mode:

(NOTE: to start in harvest mode, turn “Clean/Off /Ice selector switch to “Ice” and press “Start”)

1. Set the “Clean/Off/Ice” selector switch to the “Clean” position.
2. Push the “Start” button to start the water pump.
3. The pump can be stopped and started by the “Stop” and “Start” push buttons to purge the tubing of air.
4. When there is good water flow, turn the “Clean/Off/Ice” switch to “Ice”. The machine will then start in a harvest (thaw) period with the compressor running.
5. At the termination of the harvest period, the machine will begin the freeze period.

**NOTE: Be sure to observe several cycles of ice production to confirm the satisfactory operation of the machine.**

6. Complete the remaining part of the “Warranty Registration/Start-Up Report” and return it to the Vogt Ice LLC.

## START-UP AND OPERATION

**! CAUTION !**

**If it should become necessary to add refrigerant to the system, charging valve (28) is provided for this purpose. Be sure to follow all local and federal regulations regarding the handling of refrigerants and their illegal emission into the atmosphere.**

**! CAUTION !**

Check the refrigerant level after the machine has operated for a few cycles. It should be slightly above the minimum operating level, as indicated on the receiver, a few minutes prior to start of a thawing period. If this level is low at this time, sufficient refrigerant should be added to the system to raise the level above this point. Add only a small quantity (10 lbs. or less) at a time and operate the machine several cycles to check the level before adding additional refrigerant. Refrigerant may be added as a liquid through the charging valve (28) only while the machine is operating. It is important that no air or other non-condensable gas enter the system when charging refrigerant into the unit. It is also possible to check the refrigerant level by pumping machine down (See page 9-15). When the machine is pumped down, a liquid level should be observed in the gage glass on the receiver.

**Adding Refrigerant.** When adding refrigerant, use the following procedure:

1. Make connection between charging valve and refrigerant cylinder using hose or pipe suitable for R-22 or R-404a service. See instruction card attached to refrigerant cylinder.
2. Open valve on R-22 or R-404a cylinder and purge air out of charging line at the charging valve connections.
3. Open charging valve.
4. Refrigerant can be added only during the freeze cycle. The charging valve must be closed when the freezer is in a harvest.

In order to check the total charge in the system, it is necessary to transfer all refrigerant to the receiver. A total pumpdown procedure should be performed.

See the nameplate for the approximate refrigerant charge for the machine. Remember that the total charge will vary for air-cooled machines with remote air-cooled condensers.

**! DANGER !**

**Immediately close system charging valve at commencement of defrost or thawing cycle if refrigerant cylinder is connected. Never leave a refrigerant cylinder connected to system except during charging operation. Failure to observe either of these precautions can result in transferring refrigerant from the system to the refrigerant cylinder, overfilling it, and possibly causing the cylinder to rupture because of pressure from expansion of the liquid refrigerant.**

**! DANGER !**

**OPERATING TIPS**

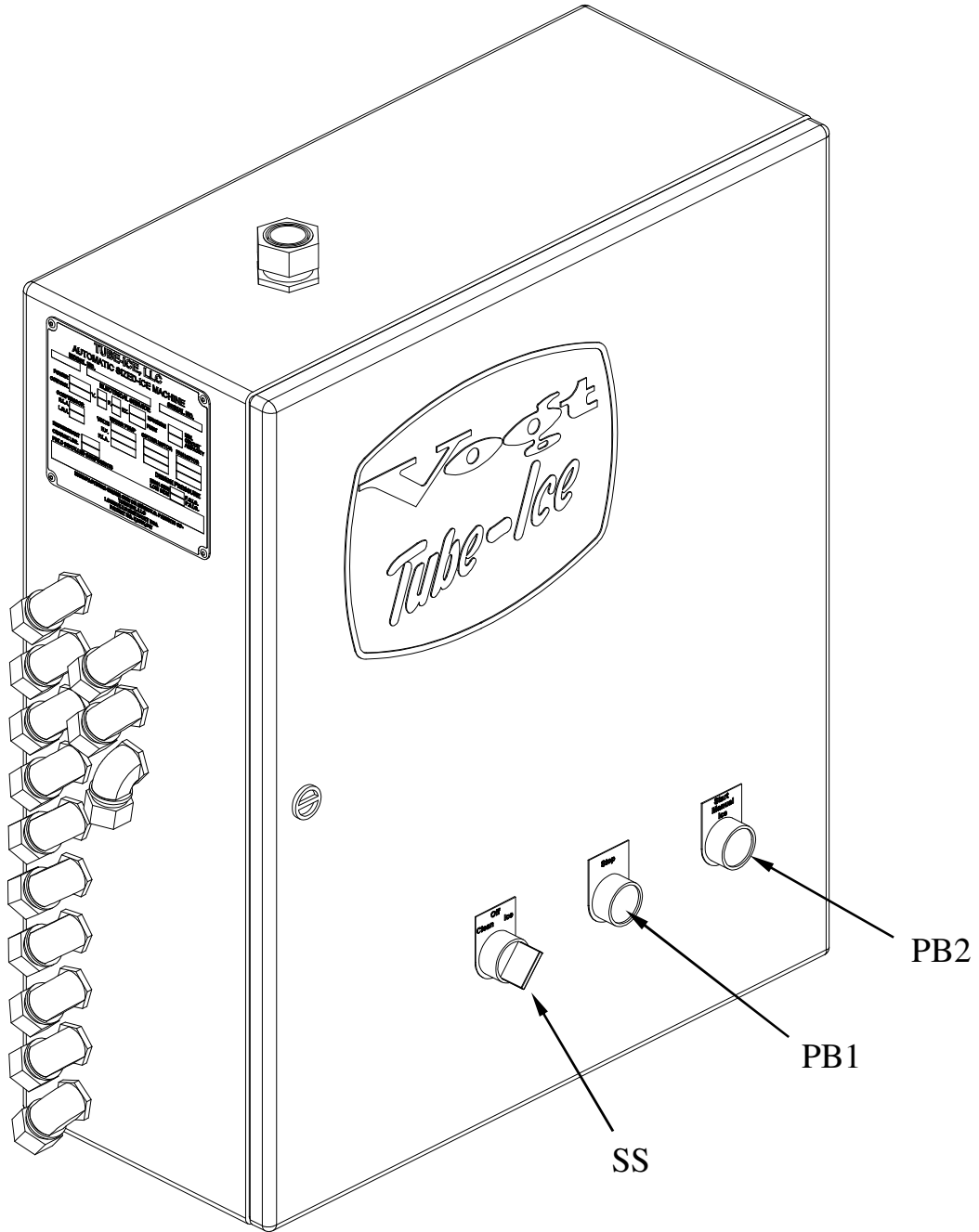
- If the operation of your machine is not controlled by a timer, bin level control or some other mechanism to automatically start and stop ice production, you should use **ONLY** the “Clean/Off/Ice” selector switch to start and stop machine.

By turning the “Clean/Off/Ice” switch “Off”, the machine will stop after the next harvest cycle.

- Do not use the “Stop” pushbutton or the machine disconnect for normal shutdown of the machine.
- Throw the “Disconnect” only in an emergency or for safety when performing certain service or repairs to the machine. The compressor crankcase heater is de-energized when the disconnect is thrown.
- The “Start” push button can be used to initiate a harvest cycle. When it is pushed during a freeze cycle, it will immediately initiate a harvest cycle.
- When the machine is stopped with no power to the control circuit and the “Start” button is pushed, the machine will begin in a harvest cycle when operation is resumed.

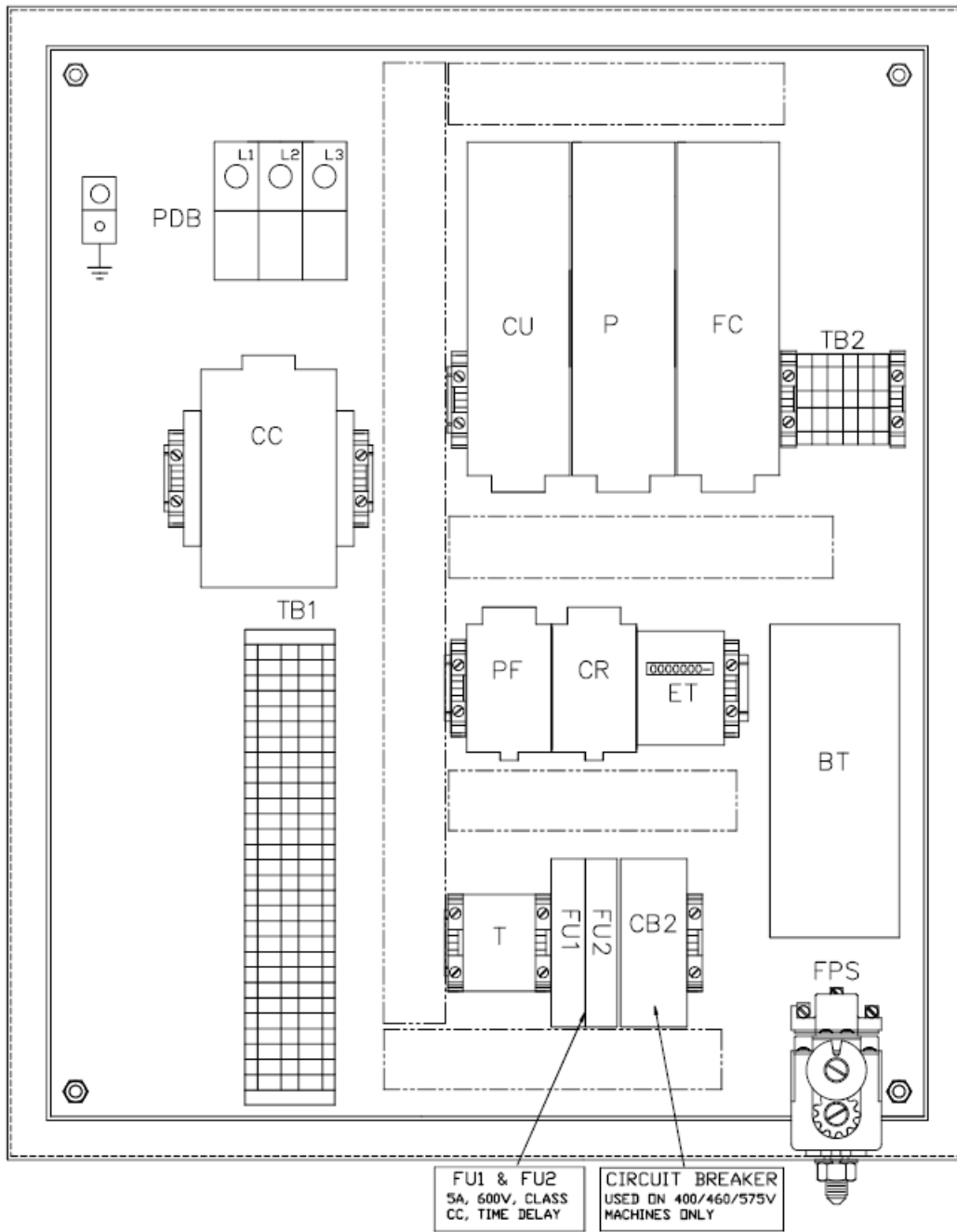
Blank page

## 6. Electrical Controls

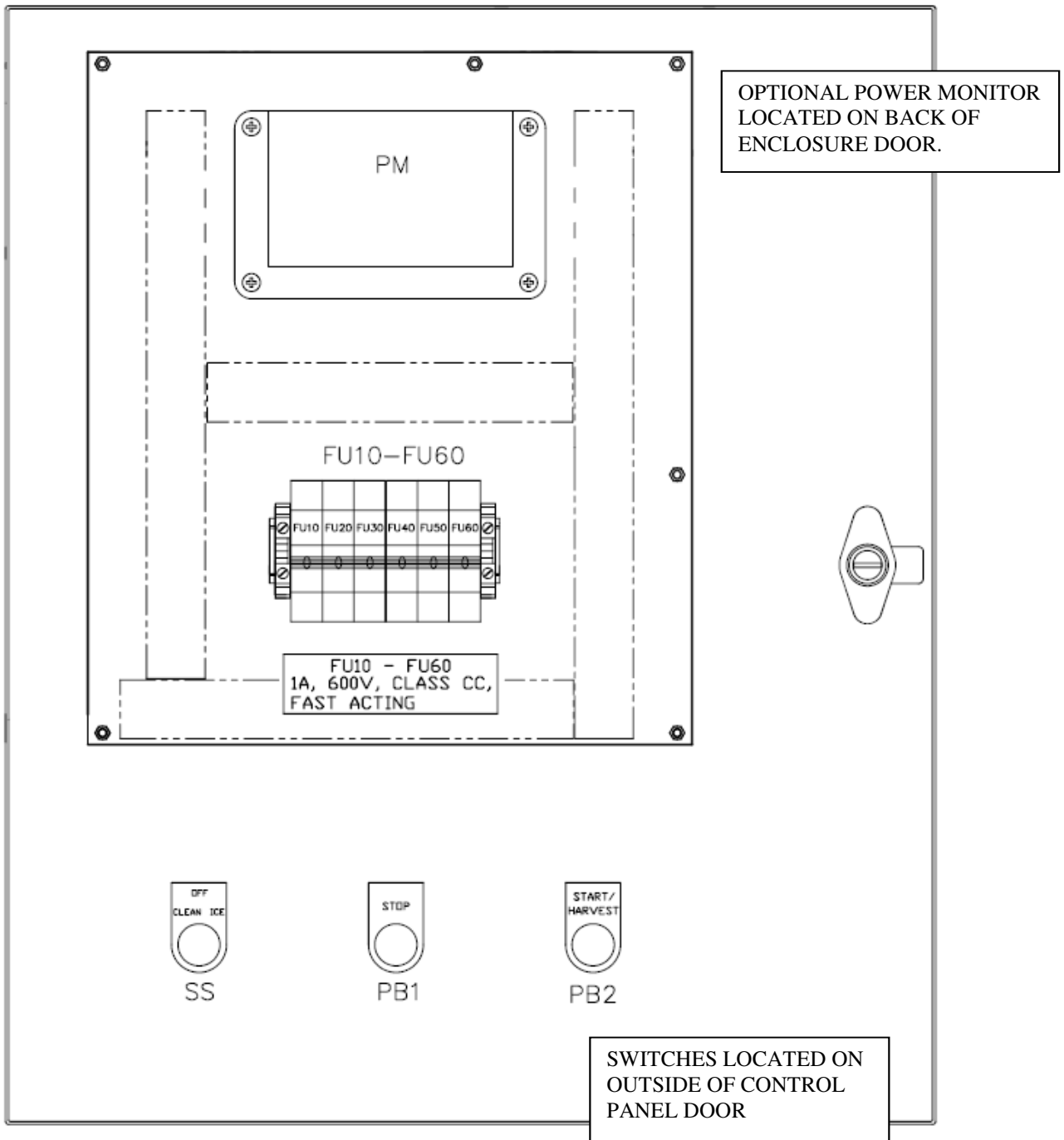


**FIGURE 6-1**  
**Control Panel (Standard)**

ELECTRICAL CONTROLS

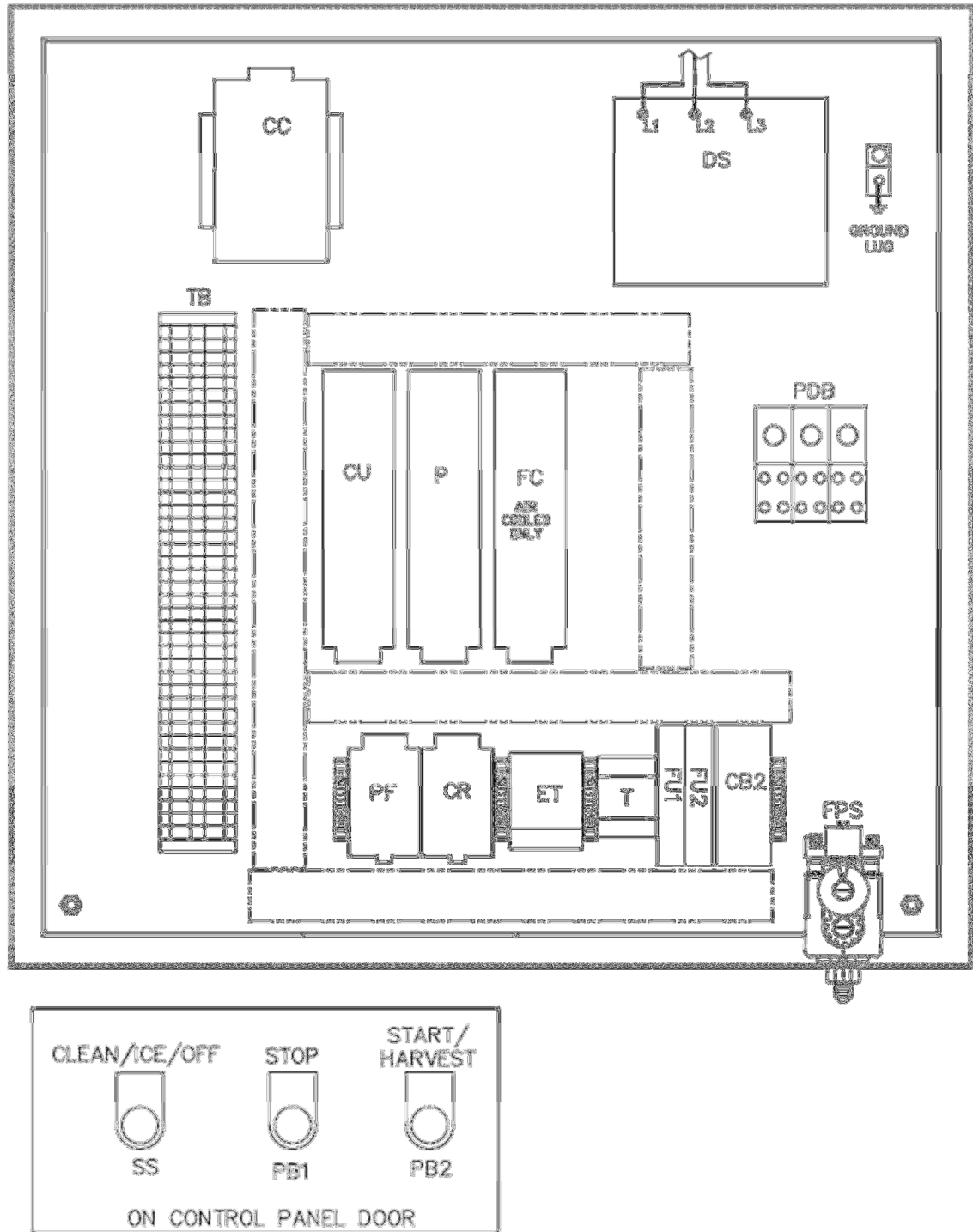


**FIGURE 6-2**  
**Control Panel Components (Standard)**



**FIGURE 6-2A**  
**Control Panel Door (Standard) and Optional Power Monitor**

ELECTRICAL CONTROLS



**FIGURE 6-2B**  
**Control Panel Components (CE & Australian Approved)**

## ELECTRICAL CONTROLS

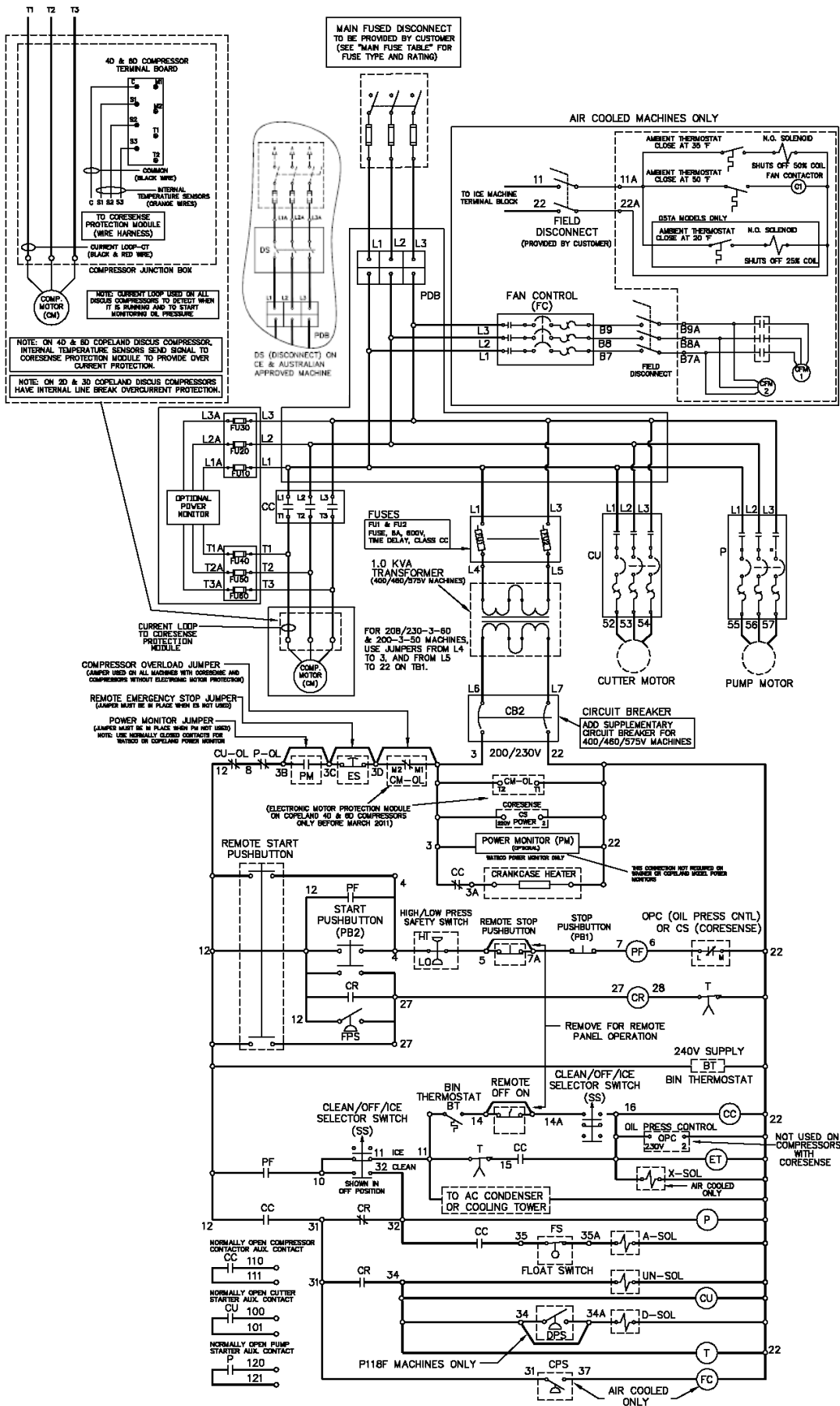
Item No.	Vogt Part No.	Description
AX	12A7518E33UL	Aux Trip Indicator, 6A, 1NO / 1NC
BT	12A2117G09	Bin Thermostat
CB2	12A7515E22	Control Circuit Breaker, 6 Amp, 2 Pole (400V & 460V machines only)
CC 200V, 208/230V	12A7516E33	Compressor Motor Contactor (85 Amp, 3 Pole)
	12A7518E30	Aux. Contact (10 Amp, 1 N.O./1 N.C., Side Mount)
	12A7518E32	Aux. Contactor (5 Amp, 2 N.O., Top Mount)
CC 400V/ 460V	12A7516E28	Compressor Motor Contactor (37 Amp, 3 Pole, w/N.O. Aux)
	12A7518E30	Aux. Contact (10 Amp, 1 NO/1NC, Side Mount)
	12A7518E44	Aux. Contact (2 Amp, 2 N.O., Side Mount)
CR	12A7517E27	Control Relay (10 Amp, 2 N.O./2 N.C., 208/240V Coil)
CU	12A7516E23	Contactor (9Amp, 3 Pole, with 1 N.O. Aux, 208/240V Coil)
	12A7530E54UL	Cutter Manual Motor Starter, 1.6-2.5A (200/208/230V)
	12A7530E52UL	Cutter Manual Motor Starter, 0.63-1.0A (460V)
	12A7530E53UL	Cutter Manual Motor Starter, 1.0-1.6A (400V)
ET	12B7503E17	Timer, Elapsed, Panel Mount, 220V (50Hz only)
	12B7503E18	Timer, Elapsed, Panel Mount, 220V (60Hz only)
FC Air Cooled Only	12A7516E25	Condenser Fan Contactor (16 Amp, 3 Pole, 1 N.O. Aux. Contact, 208/240V Coil)
	12A7530E57UL	Fan Manual Motor Starter, 6.3-10.0A (400/460V)
	12A7530E58UL	Fan Manual Motor Starter, 10.0-16.0A (200/230V)
FPS	12A2117E04	Freezer Pressure Switch
FU1 & FU2	12A7504E18	Fuses, 5A, 600V, Class CC, Time Delay
FU10-FU60	12A7504E29	Fuses, 1A, 600V, Class CC, Fast Acting (For use w/optional Power Monitor)
P	12A7516E23	Contactor (9Amp, 3 Pole, with 1 N.O. Aux, 208/240V Coil)
	12A7530E54UL	Pump Manual Motor Starter, 1.6-2.5A (460V, 60hz)
	12A7530E55UL	Pump Manual Motor Starter, 2.5-4.0A (400V, 50hz)
	12A7530E56UL	Pump Manual Motor Starter, 4.0-6.3A (200/208/230V, 50/60hz)
PB1	12A7500E57	Stop Push Button (Red)
	12A7500E76	Contact Block/Mounting Latch (1 N.C.)
PB2	12A7500E56	Start Push Button (Green)
	12A7500E73	Contact Block/Mounting Latch (2 N.O.)
PF	12A7516E23	Power Failure Contactor (9 Amp, 3 Pole, 1 N.O. Aux. Contact, 208/240V Coil)
PM	12A7700P01	Power Monitor, Universal Phase Protector (Optional)
SS	12A7500E61	Selector Switch, 3 Position (Clean/Off/Ice)
	12A7500E77	Contact Block/Mounting Latch (2 N.O./1 N.C.)
T	12A7503E22	Thawing Timer (Delay On Make) 100-240V
	12A7503E39	Timer Base (8 Pin, Guarded Terminal)
TB1 & TB	N/A	Main Terminal Block Assembly
TB2	N/A	Terminal Block Assembly Connections for Customer

**TABLE 6-1**  
**Control Panel Components and Part Numbers (See FIGURE 6-1, 6-2, 6-2A & 6-2B)**

## ELECTRICAL CONTROLS

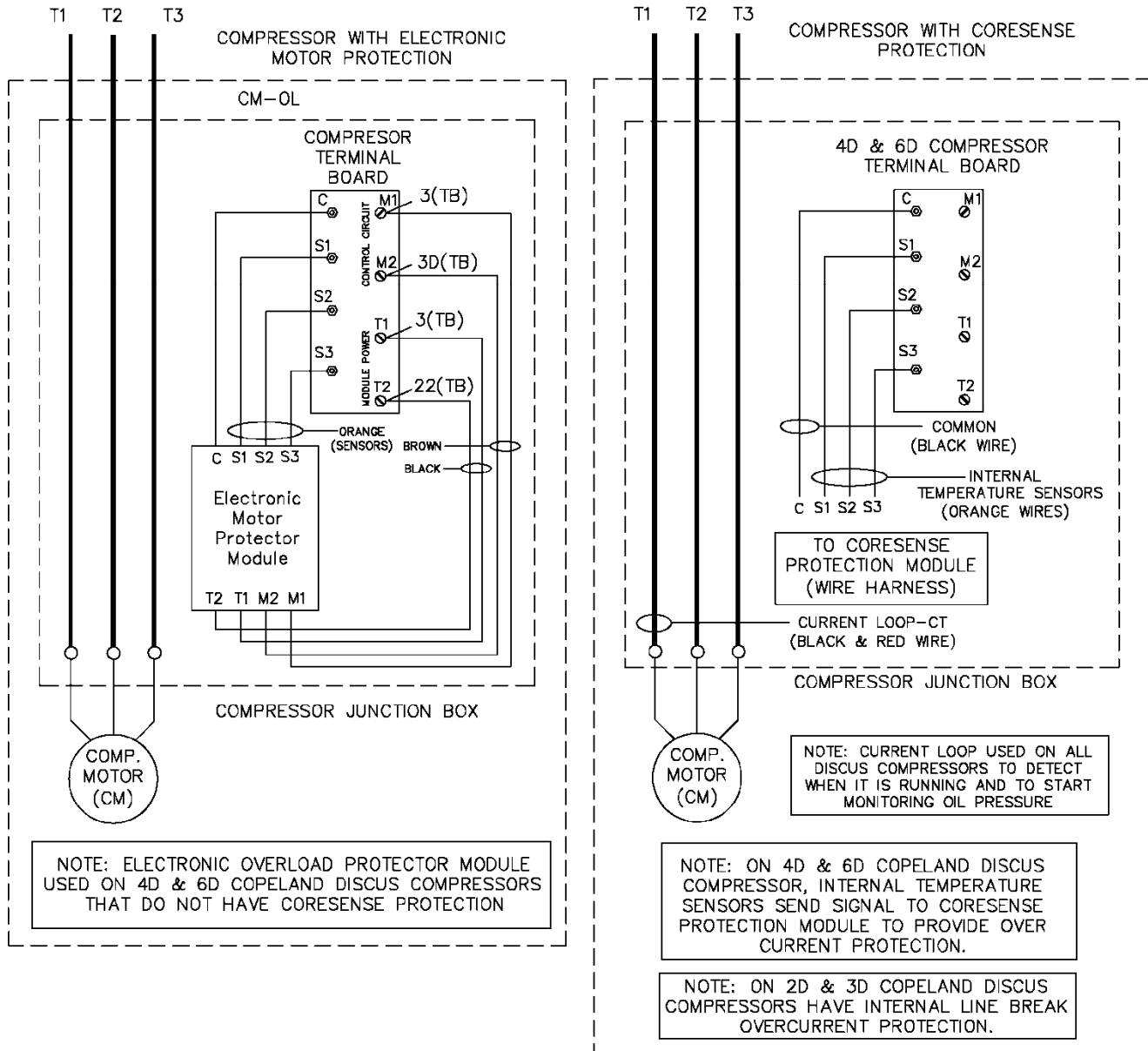
<b>Description of Component Function</b>	
AX –	Auxiliary trip indicator for manual motor starters. Switches when cutter or pump motor starter trips.
CB2 –	Overload and short circuit protection for control circuit and crankcase heater. (400/460V machines only)
CC –	Provides power to the compressor motor. Continuously energized during freezing and thawing. Auxiliary contacts control main power for control circuit components, crankcase heater, control relay and harvest timer.
CR –	Controls sequencing of Freezing and Thawing circuits. Energized during thawing period.
CU –	Cutter Motor Starter (Manual motor starter and contactor). Starts and stops cutter motor. Provides short circuit and over current protection. Stops cutter motor and ice machine in the event of a mechanical or electrical malfunction that results in excessive motor amperes.
CS –	CoreSense replaces Copeland Sentronic Oil Pressure Safety module on all Discus compressors and the Electronic Motor Protector module in 4D & 6D compressors. Note: 2D & 3D compressor will still have Internal Line Break overload protection.
DS –	Disconnect switch (CE and Australian Approved machines only)
ET –	Indicates hours of machine operation. Energized when compressor is operating.
FC –	Cutter Motor Starter (Manual motor starter and contactor). Cycles the fan motor(s) of air-cooled condenser on and off. Activated by the condenser pressure switch (Air-cooled Machines ONLY). Provides short circuit and over current protection. Stops fan motors in the event of a mechanical or electrical malfunction that results in excessive motor amperes.
FPS –	Regulates the ice thickness by reading freezer pressure and initiating the thaw period at the set point.
FU1 & FU2 –	Short circuit protection for control circuit and crankcase heater on 200/230V machines. Protection for primary side of transformer on 400/460V machines
FU10-FU60 –	Short circuit protection for power monitor (Optional)
P –	Pump Motor Starter (Manual motor starter and contactor). Starts and stops pump motor. Provides short circuit and over current protection. Stops water pump motor in the event of a mechanical or electrical malfunction that results in excessive motor amperes.
PB1 –	Used to stop machine immediately (Should be used for emergency stopping only).
PB2 –	Used for starting machine or manually harvesting. Will initiate a harvest cycle whenever pushed with the “Clean/Off/Ice” selector switch in the “Ice” position and machine operating in a freeze cycle.
PDB –	Power distribution block.
PF –	Stops the machine when there is a power failure or interruption. Also, stops the machine when the high/low pressure switch, oil pressure safety control, pump overload, cutter overload, compressor overload or the control circuit breaker is tripped. If the “Stop” button was pushed, any of the safeties tripped, or there was a power outage, the machine must be manually restarted by pushing the “Start” button.
PM –	(Optional) Phase monitor for compressor motor. Monitors voltage in / out of compressor motor contactor. Will shut machine off in voltage is outside of set parameters.
SS –	Used to select operating mode of machine. When in clean position, only the water pump will run. This allows cleaner to be circulated through the freezer without making ice. In the off position, the machine will shut down after the completion of a freeze and harvest period. In the ice position, machine will cycle on and off based on a control signal (i.e. bin thermostat or timer) or run continuously until manually stopped by setting the switch to the “Off” position.
T –	Controls the time of the thawing period.
TB –	Numbered for multiple wire connections and ease of troubleshooting.
TB1 –	Customer connections for remote Air Cooled condenser.
TB2 –	Customer connections for auxiliary contacts on cutter, pump and compressor contactors.

**TABLE 6-2**  
**Description of Control Panel Component Function**



**FIGURE 6-3**  
**Electrical Schematic All Voltages, 50-60 Hz.**

ELECTRICAL CONTROLS



**FIGURE 6-4**  
**Compressor Schematic Detail All Voltages, 50-60 Hz.**

## 7. Maintenance

**Ice Making Section.** The ice-making section of the Tube-Ice<sup>®</sup> machine should be cleaned at least twice a year (more often if water conditions cause mineral build-up). Use an approved food-grade ice machine cleaner. The water pump is used to circulate the cleaner through the system by setting the “Clean/Off/Ice” selector switch to “Clean” and starting and stopping the pump by the “Start/Manual Harvest” and “Stop” switch. For complete instructions, refer to the “Cleaning Procedure” attached to the equipment and duplicated here.

**NOTE:** Before cleaning or sanitizing any Tube-Ice machine, pump the machine down and make sure the crankcase heater is working properly. This will eliminate the possibility of refrigerant migrating to the compressor while circulating warm water through the evaporator.

### Cleaning Procedure

1. Before cleaning any Tube-Ice machine make sure the crankcase heater is working properly. When the crankcase heater is not working there is a possibility for refrigerant evaporated by warm circulating water to migrate to the compressor during the cleaning operation.
2. Set “Clean/Off/Ice” selector switch (SS) to the “Off” position. If the machine is running, it will shut down on completion of the next ice harvest period.
3. Remove ice from storage area or cover opening into it.
4. Shut off water supply and drain water tank (7) by opening drain valve (39). Remove any loose sediment from tank.
5. Close drain valve (39) and fill water tank (approximately 6 gallons) with warm water. Close the petcock on the water pump during the cleaning period.
6. Add 16 ounces (8 ounces per 3 gallons) of Nu-Calgon<sup>®</sup> ice machine cleaner or equivalent (a food grade liquid phosphoric acid) to water tank during the refill period. Note: Tank capacity = 6 gallons
7. Inspect the water distributors by looking through clear freeze cover. If required, remove the cover. Clean and remove any solid particles from the distributor orifices (two orifices in each distributor). Clean the rubber cover gasket and reinstall the cover.
8. To run the pump only, set the selector switch (SS) to the “Clean” position and press “Start”.
9. Circulate cleaning solution until deposits are dissolved or solution is neutralized. Repeat cleaning if necessary.
10. Press “Stop” button to stop pump, then drain and flush water tank with fresh water. Open water supply to machine.
11. Drain and flush tank and then refill with fresh water.
12. Clean inside of ice storage area and remove any solution that entered during the cleaning process. Remove cover if one was installed over opening into storage area.
13. Start ice-making cycle by setting the “Clean/Off/Ice” selector switch (SS) to “Ice”. Check for water leaks around the freezer cover and tighten nuts if needed
14. Adjust setting of pump petcock per instructions under “Adjustable Blow down” in Section 9.

## MAINTENANCE

**Sanitizing Procedure**

1. After pumping machine down, set “Clean/Off/Ice” selector switch (SS) to the “Off” position.
2. Remove ice from storage area.
3. Shut off water supply and drain water tank (7) by opening drain valve (39). Remove any loose sediment from tank.
4. In a clean container, mix 6 gallons of warm water (90°F–115°F / 32°C–46°C) and 9.6 ounces of Nu-Calgon® IMS-II Sanitizing Concentrate or equivalent. Note: Concentration should be 200-ppm active sanitizing solution. (Nu-Calgon® IMS-II: 1.6 ounces of sanitizer per 1 gallon of water = 200 ppm).  
Note: Tank capacity = 6 gallons
5. Close drain valve (39) and fill water tank with sanitizing solution. Close the petcock (adjustable blow down) on the water pump.
6. To run the pump only, set the selector switch (SS) to the “Clean” position and press “Start” button to circulate the sanitizing solution.
7. Mix an additional 2 gallons of warm water (90°F–115°F / 32°C–46°C) and 3.2 ounces of Nu-Calgon® IMS-II Sanitizing Concentrate or equivalent in the clean container. Note: Concentration should be 200 ppm active sanitizing solution. (Nu-Calgon® IMS-II: 1.6 ounces of sanitizer per 1 gallon of water = 200 ppm).
8. Submerge a clean sponge in the sanitizing solution and wipe all inside surfaces of water box and water box cover, including the makeup water float valve.
9. With the water pump running, add the additional 2 gallons of sanitizing solution to the water tank. Install water box cover on water tank and allow sanitizing solution to circulate for at least 20 minutes.
10. While circulating sanitizing solution, open petcock valve (adjustable blow down) and allow solution to flow down the drain. With petcock valve open, allow water to circulate for a minimum of 3 minutes.
11. Press “Stop” button to stop pump, then drain and flush water tank with fresh water. Open water supply to machine.
12. To sanitize inside the ice storage area, flood the area with sanitizing solution, making sure to wet all surfaces completely for at least 60 seconds. Note: Concentration should be 200-ppm active sanitizing solution. (Nu-Calgon® IMS-II: 1.6 ounces of sanitizer per 1 gallon of water = 200 ppm).
13. Drain, flush tank and refill with fresh water.

**Return machine to ice making operation**

1. Make sure the water tank drain valve is closed, and the “Selector” switch is in the “Off” position. Turn on the water supply and refill tank with clean water.
2. Manually open the thaw gas solenoid valve “D-valve” (18), by running the stem in. This will allow the pressure to rise in the evaporator and allow the machine to operate. After approximately 1 minute, put “D-valve” back into the automatic position.
3. When tank is full, turn the selector button to the “Ice” position and push the “Start” button for immediate start-up in the ice production mode.
4. Make use the adjustable blow down petcock is adjusted properly.

**NOTE:** The petcock should be adjusted to the minimum rate required to maintain production of clear ice. (Should be no more than 1 gallon/5 minutes)

**Water Distributors.** The water distributors are located under the freezer cover (8) at the top of the freezer. These distributors may require occasional or periodic cleaning to remove solids and foreign particles accumulated from the make-up water. The frequency of this cleaning operation will depend on the characteristics of the water supply. The cleaning operation is needed when the inside diameter of a large proportion of the ice becomes irregular (due to channeling of water), or if some of the ice is opaque, or if there is a noticeable decrease in ice capacity.

To clean distributors, stop the unit and remove the freezer cover (8) on top of the freezer. The water distributors (one in each tube) may then be removed with pliers for cleaning. Use pliers on the distributor's top part with a twisting upward motion.

**Note:** When re-installing distributors on the outside row, make sure holes are away from the gasket

		Vogt Part #		
Size Ice	Number of Tubes	Water Distributor	Freezer Cover	Freezer Cover Gasket
1"	78	12B2185N11	12A2145C06	12A2600G01
1 1/4"	48	12B2185N21		

**Table 7-1**  
**Number of Water Distributors Per Tube Size**

**Water Tank.** The production of opaque ice can indicate that the water in the water tank contains a concentrated amount of solids or salts.

Remove cover plate. Open drain valve (39). Clean tank thoroughly by flushing out with a hose and scrubbing with a stiff brush. Fill the water tank with fresh water.

When restarting the machine, be sure that the water pump is circulating water. It is possible that air may have collected in the pump impeller housing and the pump may have to be stopped and started several times to expel the air.

### Water Cooled Condenser

**Checking Operation.** Scheduled maintenance for water-cooled condensers is based primarily on the operating conditions found at the machine. The condenser should be inspected at least annually and cleaned as required. For extreme operating conditions where water quality is poor the condenser may need to be cleaned several times a year.

Proper operation of cooling towers will increase the interval between cleaning considerably. The tower overflow rate should be checked frequently. If a tower is operated with insufficient overflow, nominal 1-1/2 to 3 gallons per hour bleed depending on water quality, the resulting mineral concentration in the water can cause rapid and heavy fouling inside the condenser tubes, requiring excessively frequent cleaning. Also, these conditions often lead to severe corrosion.

Chemical additives, including those to stop algae and related growths, should be obtained only from a reputable, established supplier, and used specifically according to directions. Excessive treatment of the water can cause more harm than good and the condensers, pumps, piping, and the towers themselves may be damaged.

## MAINTENANCE

It is advisable to double-check the system to make sure that fouling is actually causing the trouble. High head pressure alone does not mean a fouled condenser.

The following possibilities should always be checked before cleaning is undertaken:

1. Non-condensables in system or faulty head pressure gauge? Check standby pressures against refrigerant tables.
2. Incorrectly set or defective water regulator valve? Check its setting and operation.
3. Partly closed compressor discharge service valve? Check its setting. Stem should be backseated.
4. High water temperatures entering condenser? Check tower fan and system.

After the above possibilities have been eliminated, determine the temperature difference between the water leaving the condenser and the refrigerant condensing temperature (saturation temperature, from pressure-temperature chart, corresponding to head pressure). If this difference is more than 10°F, cleaning is indicated because this difference indicates a good heat exchange is not being made. If this difference is less than 8°F, something other than a fouled condenser may be causing the high head pressure. In normal operation, this difference will stay between 5°F and 10°F regardless of water inlet temperature when the water flow is regulated by a pressure operated water valve. If this difference is less than 5°F, restricted water flow or a low supply pressure is indicated. A restriction can occur with foreign matter in the condenser, but it is also likely to be somewhere else in the system.

**Draining Condenser.** Draining of water cooled condensers is recommended in preparation for the winter cold where units may be left exposed to ambient temperatures below 32°F. Theoretically, it is easy to drain a condenser. In practice, the problem can be complex.

Despite the fact that a condenser may have vent and drain fittings, the opening of these fittings is not sufficient for a natural gravity flow. Water will be retained in a tube due to (1) surface tension and (2) the normal curvature between tube supports. Our experience shows that as much as 20% of the water in the condenser can be retained. To break the surface tension on the tubes and to drain all tubes completely, it is necessary to remove the back plate and actually tilt the condenser a minimum of 5 degrees. Whether water left in the tubes will cause damage during a freeze-up will be dependent upon how quickly the freeze occurs and the location of the water inside the condenser.

In the field it is recommended that the tubes be blown out individually with air. Alternatively, a minimum of 25% ethylene glycol in the system will also prevent a freeze, which can rupture the tubes.

### Water Cooled Condenser Cleaning.

<b>! CAUTION !</b>
<b>The following directions and precautions should be observed when cleaning is undertaken. The warranty on condensers is void if they are damaged by improper cleaning tools or methods. If harsh chemicals are used, be sure to follow the manufacturer's recommendations regarding safety in handling those solutions.</b>
<b>! CAUTION !</b>

**Chemical Cleaning.** Vogt Tube-Ice® makes no recommendation for any particular chemical preparation. The same chemical may not be effective for all situations.

- a) Use only preparations from an established, reliable source.
- b) Follow directions exactly, particularly regarding amounts to use, and flushing or neutralizing procedure after cleaning.
- c) Close the water supply stop valve. Remove the condenser water-regulating valve (41).
- d) Circulate the solution through the condenser until it is considered clean.
- e) Flush the condenser according to directions.
- f) Install the water regulating valve and connecting piping.
- g) Open the water supply stop valve and check for leaks.

### **Mechanical Cleaning.**

#### **Part I.**

- a) Close the stop valve in the water supply line.
- b) Drain the water from the condenser.
- c) Remove water regulating valve (41) and attached piping to the condenser.
- d) Remove the cover plate on the side of the frame to expose the condenser end plate.
- e) Remove the nuts, water plates, and gaskets from both ends of the condenser. If the gasket does not lift off with the end plate, do not try to pry it off. The seal surface may be damaged, which would cause a water leak. To free a sticking gasket, replace the water plate and tap it on the outside face with a mallet or a block of wood. After a few taps, the gasket will spring free and will then slip off with the water end plate.
- f) Gaskets need only be rinsed in running water: rust, scale or dirt will not stick to gasket material. A rag or soft brush is all that is required to remove any foreign matter.

#### **Part II.**

The inside of the water end plates and the outer tube sheet surfaces should be cleaned only with clear water and a rag or a soft bristle brush. A worn paintbrush is excellent.

These surfaces have been coated with a special material that will give years of protection against corrosion unless damaged. Never use a wire brush or a strong caustic on these surfaces.

Flush condenser tubes clear with air, water, or a piece of rag on a stick or wire. In many cases this is all that is required. If the inside surfaces are smooth, even though discolored, further cleaning is not necessary. It is not necessary to get a bright copper surface on the inside of the tubes. They will discolor almost immediately in service and the condenser has been designed with an adequate reserve for moderate fouling on these surfaces.

If, however, a rough coating remains inside the tubes after flushing and wiping, further cleaning is desirable. The color of this coating varies with water conditions, but roughness indicates cleaning tools should be used.

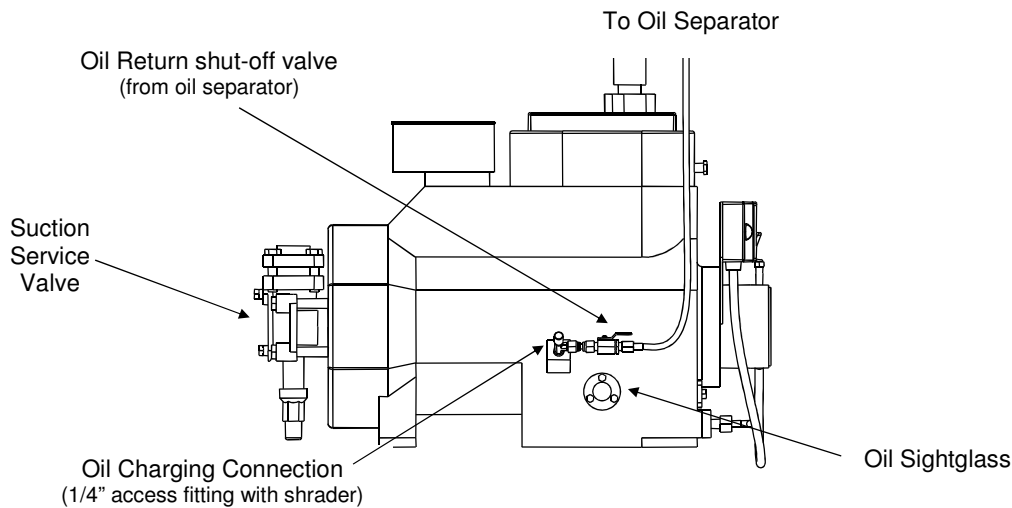
## MAINTENANCE

Any type tool to be considered should be tried first on a piece of copper tubing held in a vise or flare block. Nylon, brass, or copper brushes are recommended. If any flakes of copper appear or if score marks are made inside the tube, the tool should not be used. Never use anything with sharp or rigid edges which could cut into the copper tubing.

**Lubrication**

**Compressor.** When starting and charging the unit, the oil sight glass (33) in the crankcase of the compressor should be watched carefully for the first hour to make certain the proper lubrication is being maintained. The oil may become low in the crankcase on an initial start-up if electrical current has been interrupted to the machine, thus de-energizing the compressor crankcase heater.

Before starting the machine again, the heater should be energized for a time period of at least two hours to evaporate refrigerant that may have condensed in the crankcase during the shutdown period. If the level is low after start-up, it should begin to return after a short period of operation.



**FIGURE 7-1**  
**Copeland Discus Compressor (3D)**

The oil level should be checked frequently, particularly during the start-up operation, to see that a sufficient amount of oil remains in the crankcase. While it is important to observe the oil splash during operation, the true level can be obtained only when the compressor is stopped. With the compressor idle, the oil level should be at a height of 1/4 to 1/2 of the sight glass but never above the top of the sight glass.

Although the machine was shipped with the oil charge, which was originally added for the test operation, it may be necessary to add some oil when or if new refrigerant is added to the system.

Refrigerant	Recommended Lubricants	Type of Lubricant
R-22	Suniso 3GS, Texaco WF32, Calumet RO15 (Witco)	Mineral Oil
R-404A	Mobil EAL ARCTIC 22 CC, ICI (Virginia KMP) Emkarate RL 32S	Polyol Ester Oil

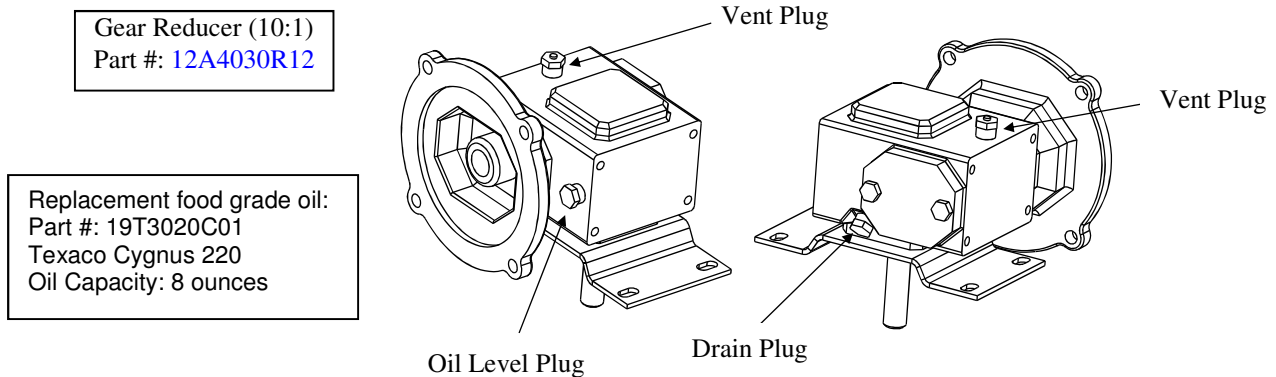
**TABLE 7-2**  
**Recommended Lubricants**

Compressor	HP	Oil Charge (oz)
3DE3R & 3DEHR	6.5	125
3DP3R & 3DPHR	7.5	125

**TABLE 7-3**  
**Compressor Oil Capacity**

An oil pump should be used to force any oil that may be required into the system. Oil may be added to the compressor through the low pressure test connection adjacent to the high/low pressure switch or through the compressor suction service valve. The compressor suction service valve should be “backseated” to shut off pressure to the gauge port when connecting the oil pump. Air should be purged from the oil pump discharge line by forcing some oil through the line before tightening the charging connection.

**Cutter Gear Reducer.** The oil level for the gear reducer should be checked if there is evidence of a leak. It should be level with the plugged opening in the side of the gear housing. Use Mobile 600W cylinder oil or equal. Change oil once a year.



Note: Ventless gear reducer used after August 2010

**FIGURE 7-2**  
**Gear Reducer**

## MAINTENANCE

**Preventive Maintenance.** A careful inspection of the Tube-Ice<sup>®</sup> machines refrigeration system for leaks and correct operational functions at time of installation will start its long satisfactory life of service. In order to insure this degree of dependability, a systematic maintenance program is recommended. Therefore, the following schedule is suggested as a minimum.

(A) Daily

1. Check “ice-out” time (maintain 30 second free running after last ice is out).
2. Check clarity of ice produced and hole size.
3. Check compressor oil level.
4. Check refrigerant charge by observing operation level in receiver gage glass (30).

(B) Weekly

1. Check system for leaks with suitable leak detector for the first four weeks of operation.
2. Check oil level and condition.

(C) Monthly (in addition to weekly checks)

1. Check calibration and operation of all controls (high and low pressure switches, oil pressure switch, etc.)
2. Check cooling tower for scaling and algae (consult water treatment suppliers for corrective measures).
3. Check water distributors in freezer for scale accumulation.
4. Check water tank for solids to be removed.
5. Check all motor drive units (compressor, cutter and pump motors, cooling tower fan and pump, etc.) for abnormal noise and/or vibrations.
6. Check oil level in gear reducer.

(D) Yearly (in addition to weekly and monthly)

1. Check entire system for leaks (see “B”).
2. Drain water from condenser and cooling tower and check condenser tubes. Check closely for damage by corrosion or scale.
3. Remove all rust from all equipment, clean, and paint.
4. Check all motors for shaft wear and end play.
5. Check operation and general condition of all electrical controls, relays, motor starters, and solenoid valves.
6. Check freezing time, ice release time, and ice out time.
7. Change oil in gear reducer box once a year.

**PRESSURE RELIEF VALVES MUST BE REPLACED AFTER 5 YEARS OF SERVICE.**

**BEFORE REPLACING RELIEF VALVE, REVIEW REQUIREMENTS PER CURRENT  
LOCAL AND NATIONAL CODE.**

NOTE: IF RELIEF VALVE DISCHARGES, VALVE MUST BE REPLACED BECAUSE SETTING OR SEAT  
TIGHTNESS MAY BE ALTERED.

CONTACT VOGT ICE PARTS DEPARTMENT FOR REPLACEMENT VALVES.  
PHONE: 502-635-3000

**For The Manager Who Depends Upon This Machine For Efficient Operation.**

“Preventive Maintenance” simply means that you or a delegated employee makes a daily visual check of your Tube-Ice<sup>®</sup> machine. Here is what to look for and why:

Daily checklist:

1. Is the machine running or is the bin full
2. Bin doors kept closed
3. Thermostat bulb in bracket
4. Ice quality (clarity and uniformity)
5. Does all ice discharge during harvest
6. Cleanliness
7. Unusual noises

**Why?** When you make these simple observations on a daily basis, you insure the smooth production of ice for your facility. When you are aware of the proper operating conditions and observe them on a daily basis, changes in these conditions can alert you to changes in the operation of the machine which may require maintenance--long before a service situation arises.

**“An ounce of prevention is worth a pound of cure!”**

**Note To Manager or Owner:**

The following page is a complete Preventive Maintenance Schedule that should be performed each 90 days. The Preventive Maintenance page may be copied and given to your service person. It should be signed, dated, and returned to you for permanent record.

MAINTENANCE

**Note To Manager or Owner:**

This page is a complete Preventive Maintenance Schedule that should be performed each 90 days. The Preventive Maintenance page may be copied and given to your service person. It should be signed, dated, and returned to you for permanent record.

**Preventive Maintenance Program**

This form can be removed and duplicated for keeping accurate records.

Model # \_\_\_\_\_ Serial # \_\_\_\_\_ Date \_\_\_\_\_

Customer/Address \_\_\_\_\_  
 \_\_\_\_\_

Mgr. Name \_\_\_\_\_ Service Tech Name \_\_\_\_\_

The following service performed and checked:

- \_\_\_\_\_ Last maintenance performed (approx. date)
- \_\_\_\_\_ Scale condition of water tank & tubes (good - fair - poor)
- \_\_\_\_\_ All drains freely draining (water tank, drip pan, ice bin)
- \_\_\_\_\_ Water distributors cleaned
- \_\_\_\_\_ Ice machine cleaner circulated through system
- \_\_\_\_\_ Condenser clean (if applicable)
- \_\_\_\_\_ Voltage at machine (actual reading) \_\_\_\_\_, \_\_\_\_\_, \_\_\_\_\_
- \_\_\_\_\_ Compressor amps (halfway through the freeze cycle) \_\_\_\_\_, \_\_\_\_\_, \_\_\_\_\_
- \_\_\_\_\_ Cutter motor amps (cutting ice) \_\_\_\_\_, \_\_\_\_\_, \_\_\_\_\_
- \_\_\_\_\_ Water pump amps \_\_\_\_\_, \_\_\_\_\_, \_\_\_\_\_
- \_\_\_\_\_ AC condenser motor amps (if applicable) \_\_\_\_\_, \_\_\_\_\_, \_\_\_\_\_
- \_\_\_\_\_ Crankcase heater heating
- \_\_\_\_\_ Refrigerant leak (okay - high - low)
- \_\_\_\_\_ Leak checked system \_\_\_\_\_ leaks found & repaired
- \_\_\_\_\_ Compressor oil level (i.e., 1/4 - 1/2 - 3/4 - low - high)
- \_\_\_\_\_ Gear reducer oil (okay - low)
- \_\_\_\_\_ PSIG, low pressure switch set @
- \_\_\_\_\_ PSIG, high pressure switch set @
- \_\_\_\_\_ Bin stat(s) installed and operating properly
- \_\_\_\_\_ Make-up water float valve adjusted okay
- \_\_\_\_\_ Adjustable blowdown adjusted for clear ice

CYL \_\_\_\_\_ CRU \_\_\_\_\_ Suction PSIG at end of freeze  
 CYL \_\_\_\_\_/\_\_\_\_\_ CRU \_\_\_\_\_/\_\_\_\_\_ Suction PSIG during harvest (high/low)  
 CYL \_\_\_\_\_ CRU \_\_\_\_\_ Discharge PSIG at end of freeze  
 \_\_\_\_\_ °F/°C at machine \_\_\_\_\_ °F/°C outside ambient (at condenser if applicable)  
 \_\_\_\_\_ °F/°C make-up water temperature

- \_\_\_\_\_ Freeze cycle time (minutes)
- \_\_\_\_\_ Harvest cycle time (minutes)
- \_\_\_\_\_ First ice out (seconds)
- \_\_\_\_\_ All ice out (seconds)
- \_\_\_\_\_ Pounds of ice per cycle

Capacity check:  $\frac{\text{ice weight per cycle}}{\text{total cycle time (min)}} \times 1440 = \text{_____ lbs. (24 hr. capacity)}$

Remarks: \_\_\_\_\_  
 \_\_\_\_\_

## **8. Troubleshooting**

**NOTE:** With the exception of bin control, anytime the machine stops, it must be manually re-started by pushing the "Start" push-button. If it stopped while in a freeze cycle, it will then start in a thawing cycle.

Always check the machine **thoroughly** after remedying the problem to prevent the same cause from reoccurring.

<b><u>Symptom</u></b>	<b><u>Page</u></b>
Machine Won't Run	8-2 & 8-3
Freeze-up Due To Extended Freeze Period	8-4
Freeze-up Due To Ice Failing To Discharge	8-5
Low Ice Capacity	8-6
Low Compressor Oil Level	8-7
Poor Ice Quality	8-8
High Head Pressure (Water-Cooled Machines)	8-9
High Head Pressure (Air-Cooled Machines)	8-10

## TROUBLESHOOTING

**SYMPTOM: Machine won't run.**

<b>POSSIBLE CAUSE</b>	<b>POSSIBLE REMEDY</b>
Power failure ++ Intermittent power interruption	Check electrical fused disconnect or circuit breaker supplying power to the machine. If power has been off, <b><u>make sure</u></b> the compressor crankcase heater is energized, the crankcase is warm, and there is no liquid refrigerant in the crankcase prior to running the machine. Push the "Start" button to initiate startup in a thawing cycle.
One of the 3amp circuit breaker (CB) in the control panel tripped.	Check compressor crankcase heater, coils of relays, contactors, starters, solenoid valves, and thawing timer for a ground. Repair or replace any defective part, and replace fuse. Make sure there is no liquid refrigerant in the compressor crankcase prior to re-starting the machine.
High/Low safety pressure switch tripped.	If the machine stops by low-pressure cutout, the switch will reset automatically when the pressure rises to the " cut in " setting. If it stops by high-pressure cutout, the switch will have to be manually reset after the pressure drops below the " cut-in " setting. Check switch settings and push the "Start" push button to start the machine in a thawing cycle. Check the head pressure during the next freeze cycle. See FIGURE 9-4, Section 9, (High/Low Pressure Switch).

**SYMPTOM: Machine won't run (CONT.)**

<b>POSSIBLE CAUSE</b>	<b>POSSIBLE REMEDY</b>
Low oil pressure switch tripped.	If the machine stops by low oil pressure cutout, the switch will have to be manually reset. Check the crankcase oil level. Restart the machine by pushing the "Start" push button. Check the oil level and net oil pressure (net oil pressure = pressure reading at the oil pump end bearing housing minus suction pressure). The oil level should be 1/4 - 3/4 level in the glass. If above 3/4, drain some oil out. See page 9-8, (Oil Pressure Sensor).
Cutter motor overload tripped.	Check and clear the cutter area and ice discharge path of all ice. Check voltage and overload range adjustment against motor rating. Reset the switch and restart the machine by the "START" push button. Check the cutter operation and motor amp draw. If tripping repeats, but ice is not jammed, check the cutter bearing for wear, the gear reducer for resistance, and the motor for defect or single phasing.
Pump motor overload tripped.	Check voltage and overload range adjustment against motor rating. Reset the switch, set the "Ice/Clean" switch to the "Clean" position and restart the machine by the "Start" push button. Check the pump operation and motor amps. If tripping repeats, check for a defective overload, defective motor, or single phasing.
Bin thermostat or bin level control stops machine.	Adjust or replace the bin stat or level control. Make sure bin stat bulb or level control is located properly in the bin. See FIGURE 3-11, Section 3 (Bin Thermostat).
Defective control panel component such as, PF, CMS, PB1, CB, T, Etc.	See FIGURE 6-3, Section 6 (Wiring Schematic). Check for open circuit. Refer to FIGURE 6-2, Section 6 (Control Panel) to identify parts. Replace defective part, restart machine and check power supply and current draw.

## TROUBLESHOOTING

**SYMPTOM: Freeze-up due to extended freeze period.**

<b>POSSIBLE CAUSE</b>	<b>POSSIBLE REMEDY</b>
Freezer pressure switch setting too low.	Adjust freezer pressure switch, or replace if defective. See FIGURE 9-3, Section 9.
Water tank drain valve (39) open or leaking, or make-up water float valve (12) stuck open.	Close valve, repair, or replace as necessary.
Thawing gas solenoid valve (18) leaking through during the freeze cycle.	Check the manual opening stem to make sure it is in the automatic position (stem screwed out). Check for leakage through the valve by sound and temperature difference. Close the stop valve (90) at the receiver to confirm suspicion of leakage. Repair or replace the valve as needed.
Float switch stuck or failed in the closed position.	Check to make sure the float switch is opening and closing.
“A” valve (20) stuck open	Check to make sure the “A” Valve is not in the manual open position. Disassemble valve and inspect for debris that could hold the valve open.

**SYMPTOM: Freeze-up due to ice failing to discharge.**

<b>POSSIBLE CAUSE</b>	<b>POSSIBLE REMEDY</b>
Insufficient heat for thawing because of low condensing pressure, non-condensables (usually air) in system, low refrigerant charge, or thaw gas solenoid valve stuck closed.	The head pressure should be maintained at approximately 210 PSIG for R-22 or 250 PSIG for R-404a, which relates to 105 °F (37.8 C). This is done by a water-regulating valve (water-cooled units) FIGURE 9-5A, Section 9, or a Fan cycling switch (air-cooled units) FIGURE 9-5B, Section 9. If non-condensables are present with the refrigerant, the saturated temperature will not relate to the pressure reading at the receiver. The refrigerant level in the receiver should be near the operating mark at the end of a freezing cycle to provide enough volume for harvesting. (1" = approx. 5.5 lbs. of R-22 or R-404a).
Thawing time too short.	Check the thaw timer (T), which should be adjusted to allow all the ice to clear the cutter and ice discharge opening with at least 30 seconds to spare.
Cutter or cutter disc does not turn.	Check cutter reducer and drive gear for proper operation and alignment. Check for broken cutter disc or drive pin and replace as necessary.
Ice backs up into cutter or discharge opening, jamming cutter	Ice mushy due to concentration of solids in the water tank. Perform "Cleaning Procedure" and check automatic and adjustable blowdown. If the machine discharges ice into a chute, it should slope at an angle of 30 degrees for cylinder ice and 45 degrees for crushed ice. Check bin stat or level control to make sure it will stop the machine before ice backs-up into the cutter.
Extended freeze period.	Check freezer pressure switch adjustment; see FIGURE 9-3, Section 9, (Freezer Pressure Switch) and TABLE 11-6, Section 11 (Operating Vitals).
Compressor not unloading.	Check compressor amps during harvest. A noticeable drop in amperage should occur. Check unloader solenoid coil. If coil is okay, replace unloader head assembly.

## TROUBLESHOOTING

**SYMPTOM: Low ice capacity.**

<b>POSSIBLE CAUSE</b>	<b>POSSIBLE REMEDY</b>
Low refrigerant charge.	Check for and repair leaks, and add refrigerant.
Restriction in liquid line.	Check for a partially closed valve or an obstruction at the drier, strainer, solenoid valve, or expansion valve. The liquid line will normally have frost on the downstream side of a restriction, especially as the suction pressure decreases.
TXV overfeeding.	Check freezer superheat. Average superheat should be between 8 - 10 deg F. Before adjusting TXV, make sure all other potential liquid overfeed causes have been checked. Check TXV bulb for proper insulation and contact on suction line. Make sure machine is clean and there is proper water flow.
Thawing gas solenoid valve (18) leaking through during the freeze cycle.	Check the manual opening stem to make sure it is in the automatic position (stem screwed out). Check for leakage through the valve by sound and temperature difference. Close the stop valve (90) at the receiver to confirm suspicion of leakage. Repair or replace the valve as needed.
Water distributors at top of freezer may be stopped up.	Remove freezer cover and clean the distributors. See Water Distributors, Section 7.
Inadequate water for ice making.	Check water pressure (30 PSIG minimum recommended). Check for a restriction in the water supply line or at the make-up water float valve.
Make-up water float valve (12) stuck open, adjusted too high, or water tank drain valve (39) open or leaking	Repair, replace or adjust float valve, or close, repair, or replace water tank drain valve.
Controls for regulating freezing and thawing cycles not adjusted properly.	For highest capacity, cylinder ice should have a small hole and crushed ice should be about 3/16" thick. Check the freezer pressure switch and thaw timer for proper adjustment, Section 9.
Excessively high head pressure.	Check water regulating valve or fan control adjustment. Check to make sure the WC or AC condenser is clean. Check refrigerant tables for pressure/temperature relation.
Warm make-up water for ice making.	Capacity of the machine is proportional to ice making water temperature. Warmer water will reduce the ice making capacity. See Section 10, Capacity Table.
Drain valve (39) open.	Close drain valve (39).

**SYMPTOM: Low compressor oil level.**

<b>POSSIBLE CAUSE</b>	<b>POSSIBLE REMEDY</b>
Oil separator not returning oil.	Check oil separator float and oil return stop valve (70) and line for a restriction. The oil return line should be above ambient temperature most of the time as it returns oil. It may be cooler at the start of a freeze cycle. Repair or replace defective parts.
Repeated short cycling (refrigerant carrying oil out of compressor).	Usually caused by freeze-up, low refrigerant charge, low head pressure, faulty timer, faulty pressure switch or expansion valve clogged. Use process of elimination.
Worn piston rings.	This condition is hard to detect without dismantling the compressor and checking piston ring tolerances. Normally there will be a little puddle of oil lying on top of the piston when the head and valve plate are removed. It is best to replace the compressor.

## TROUBLESHOOTING

**SYMPTOM: Poor ice quality.**

<b>POSSIBLE CAUSE</b>	<b>POSSIBLE REMEDY</b>
Excessive concentration of solids in the water tank usually indicated by a build-up of mineral deposits on the sides and bottom of the tank.	Perform a cleaning procedure as well as removing the freezer cover and cleaning the water distributors. Adjust continuous blowdown.
Insufficient water supply indicated by a low level in the tank.	Check water pressure (30 PSIG is recommended minimum). Check for a water line restriction, partially closed valve, or defective make-up water float valve. Make sure the water tank drain valve is closed.
Water pump rotation wrong direction.	Check rotation in relation with arrow on pump housing, and reverse two wires at the motor if necessary.
Low refrigerant charge.	Check refrigerant level mark on the receiver, and on the painted portion of the gage glass guard. Perform a pumpdown if necessary. Be sure to close the gage glass cocks after checking the level.
Insufficient blowdown during harvest	Check for proper operation of the blowdown siphon and restrictions or traps in the water tank drain assembly.

**SYMPTOM: High head pressure. (Water-cooled machine)**

<b>POSSIBLE CAUSE</b>	<b>POSSIBLE REMEDY</b>
Misadjusted or defective water regulating valve	Adjust or replace the valve. Never adjust the valve stem as far open as it will turn, because it will not close when the head pressure drops.
Insufficient water supply.	Check size of water line and pump output at the condenser. Refer to the specification sheet for water requirements. Check cooling tower sump level and make-up water supply.
Cooling tower needs maintenance.	Check cooling tower fan belt and tighten or replace as needed. Check spray nozzles and sump screen and clean as needed.
Non-condensables (usually air) in system.	Check refrigerant tables for correct pressure/temperature relation. If non-condensables are present, Perform a total pumpdown, let stand for at least 6 hours, allowing non-condensables to gather in the upper part of the receiver. Evacuate the freezer and attach a recovery unit to the top receiver purge valve (59). Open the valve and recover the vapor for about five minutes. When the freezer is evacuated, open the thaw gas solenoid valve manually for about 15 seconds letting the top vapor in the receiver blow into the freezer. Close the solenoid valve and evacuate the freezer again. Evacuate to 500 microns and restart the machine.
Fouled (dirty) condenser.	Follow the diagnostic procedure outlined on page 7-3, Section 7, and clean the condenser per instructions under Condenser Cleaning,

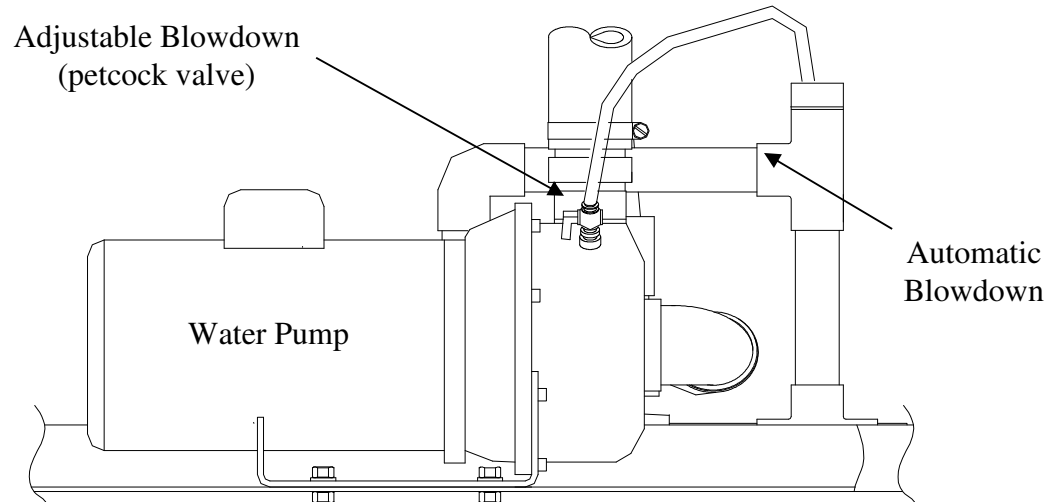
## TROUBLESHOOTING

**SYMPTOM: High head pressure (Air-cooled machine).**

<b>POSSIBLE CAUSE</b>	<b>POSSIBLE REMEDY</b>
Condenser fan(s) not running.	Defective motor, fan control switch, fan contactor. Replace defective part. Check condenser fan disconnect for thrown switch, or blown fuse. Replace fuse and reset switch. If the condenser is split, check the normally open solenoid valve to make sure it is open; also check the fan sequencing thermostats and fan motor contactors to make sure they are functioning properly. Replace any defective parts.
Dirty condenser causing restricted airflow.	Visually inspect condenser and clean as necessary.
Non-condensables (usually air) in the system.	Follow same procedure as specified for removing non-condensables from Water Cooled machine, <b>except</b> evacuate the air-cooled condenser also.

## 9. Service Operations

**Adjustable Blowdown (for clearer ice)** A petcock is installed on the overflow of the water pump to provide means for obtaining blowdown from the water tank during the freezing period. The petcock was set at the factory to discharge enough water during the freeze cycle to produce clear ice. After installation it should be adjusted to the minimum rate required to maintain clear ice and checked after a few days of ice making.



**FIGURE 9-1**  
**Water Pump / Blowdown Assembly**

**Automatic Blowdown (Harvest Cycle).** A feature of this machine is the automatic blowdown (40) which is provided to eliminate or reduce the necessity for frequent flushing or cleaning of the water tank (7) and to remove accumulated salts or solids in the water as a result of the freezing action. During the harvest water returning from the freezer raises the tank level and causes an overflow of water which creates a siphon to remove a fixed amount of water from the tank.

**Float Valve (make-up water).** Part #: [12A4200H0401](#) The make-up float valve (12) maintains the proper pumping level in the water tank for ice making. The valve should be set to maintain a water level in the water tank during the freezing period, so that there will be a quantity of by-pass or blowdown only during the thaw mode. The water level during the freeze mode should always be below the by-pass piping to prevent excessive waste of cold water, resulting in loss of ice capacity.

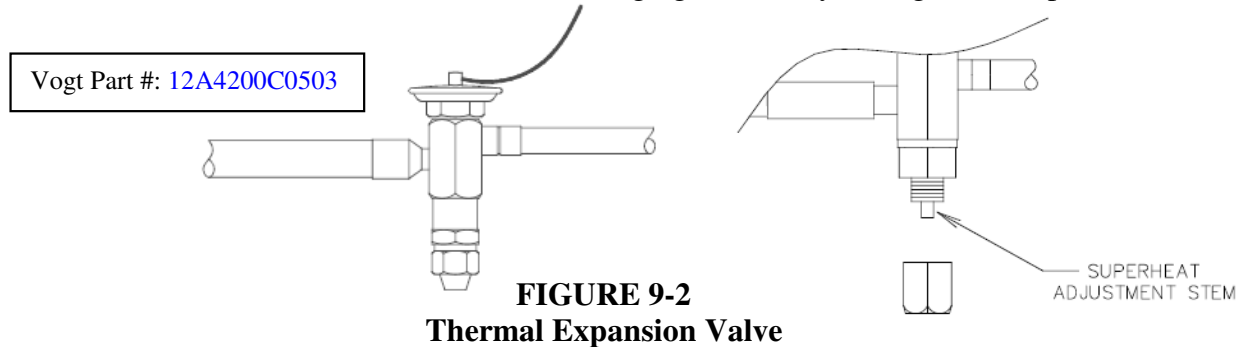
If it should become necessary to clean the float valve, close the stop valve in the make-up water line to the machine and remove the float valve. After the valve has been cleaned and reinstalled, check to ascertain if the proper water level is being maintained. After the machine is stopped and the water in the tank seeks its normal level, there should be no water flow through the float valve or drain by-pass.

It is advisable to install a large area strainer in the water supply line to protect the float valve from dirt or solids in the water, which would necessitate frequent cleaning.

## SERVICE OPERATIONS

**Expansion Valve.** The expansion valve was adjusted before shipment and it is rarely necessary to change this setting.

If considerably less ice than shown in TABLE 11-5 is being produced per discharge, check the water supply, circulating water pump, water distributors, liquid line valve, refrigerant level, freezer pressure switch and all other avenues BEFORE changing the factory setting of the expansion valve.



**FIGURE 9-2**  
**Thermal Expansion Valve**

**Superheat.** Superheat is the difference between the refrigerant vapor temperature and its saturation temperature. (Translate the pressure to saturated temperature and subtract from the actual temperature.)

**Checking Superheat.** Follow this procedure:

1. Attach an accurate pressure gage to the freezer-charging valve (#28).
2. Using a digital thermometer, attach the thermocouple to the suction line directly below and in-line with the existing TXV sensing bulb.
3. Hold the thermocouple in place with tape and insulation to assure good contact and a true reading.
4. Operate the machine and monitor the superheat during the freeze cycle after the first four minutes and at two minute intervals for at least two cycles.
5. Adjust the valve only 1/4 turn at a time. Close (turn stem in) to raise superheat. Open (turn stem out) to lower superheat. Monitor at least two cycles after each adjustment before adjust further.

If the valve cannot be adjusted satisfactorily, check the bulb insulation as follows:

1. Remove the insulation from the sensing bulb.
2. Loosen the bulb clamps and remove the bulb.
3. Clean and polish the sensing bulb and suction line to assure maximum contact between them.
4. Install the bulb in the same place tightening the clamps securely.
5. Replace the insulation around the bulb making sure it is well sealed. Repeat the adjustment procedure and if you are still unable to accomplish the proper superheat setting, replace valve.

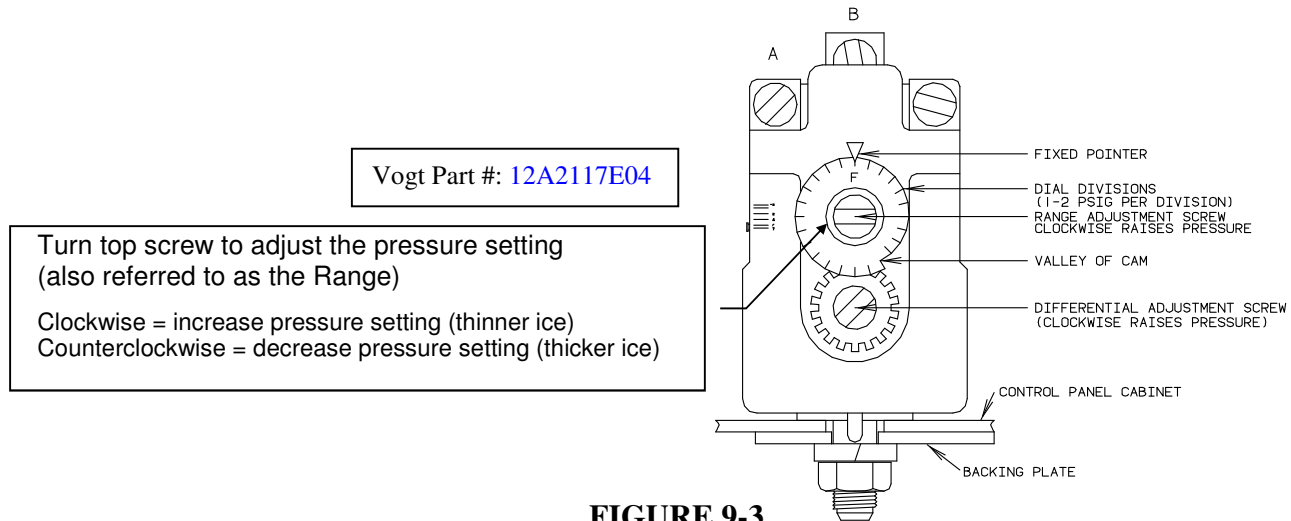
When installing a new valve, be sure to use the proper soldering techniques to prevent overheating the valve body, which could damage the superheat spring and result in flood back problems.

When soldering:

1. Wrap a wet cloth around the valve body and element.
2. Direct the flame away from the valve body.
3. Apply only enough heat to flow the alloy material into all the joint areas. Do not overheat.
4. After the brazing alloy has set, quench or apply a wet brush or swab to remove the flux residue. Use Emery cloth or a wire brush if necessary.

**Freezer Pressure Switch.** The freezer pressure switch (FPS), located inside the control panel, controls the freezing time period for the production of cylinder or crushed ice.

This switch was set at the factory to produce ice of recommended thickness. Look at the “Certificate of Test” which was provided with the machine for a sample set of pressure readings with corresponding time periods and water temperatures. Also see TABLE 10-6, Operating Vitals for typical settings. Do not make adjustments until several ice discharging cycles have been completed.



**FIGURE 9-3**  
**Allen Bradley Pressure Switch**

The following procedure is recommended for initially setting an AB pressure switch that has **not** been previously adjusted:

1. Turn the bottom screw (differential) approximately 1/2 turn to the Left (counter clockwise). The pointer arrow, which is at the top middle of the switch, will be at the “F” setting.
2. Turn the top screw (range adjustment) approximately 4 1/2 turns to the Left (counter clockwise). The pointer on the range setting will be between 40 psi and 50 psi.
3. After the machine is running, the range adjustment (top screw) will have to be fine-tuned to get the proper ice thickness. (Clockwise = Thinner Ice) (Counter Clockwise = Thicker Ice)

The freezing time can be such that a small percentage of the ice is frozen solid. If so, some ice from the top and bottom of the freezer should have a small hole in the center to insure that the freezing time has not been extended to where a loss in capacity would result.

It is preferable that the freezing cycle be such that a small diameter hole remains in the center of the ice cylinder. (1/16” diameter for 7/8” diameter ice, 1/8” diameter for 1 1/8” diameter ice, 1/4” diameter for 1 3/8” diameter ice) This insures that the freezing cycle is not extended unnecessarily and eliminates a possible opaque core in the center of the ice.

When crushed ice is produced, the freezer pressure switch (FPS) (FIGURE 9-3) should be set to produce ice having a wall thickness of approximately 3/16”.

## SERVICE OPERATIONS

**High-Low Pressure Safety Switch.** The high-low pressure switch (HPS) (FIGURE 9-4) is a two pole dual function switch. Located in the machine mounted to the frame near the compressor. It protects the machine from possible damage due to abnormal pressure during operation.

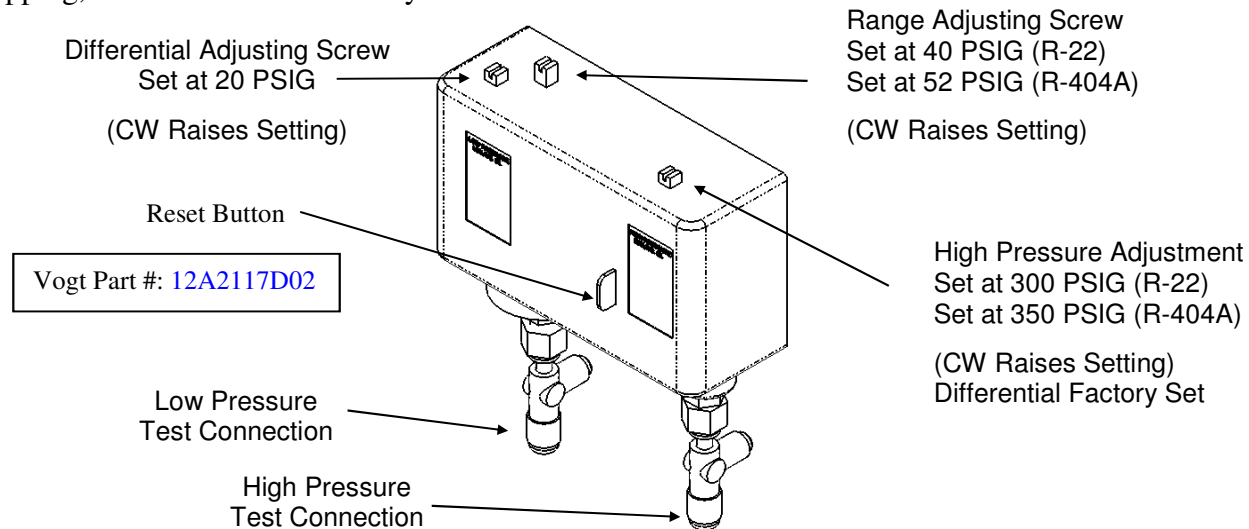
<b>! CAUTION !</b>
<b>When this switch causes the machine to stop, the cause should be identified and corrected before resuming normal operation.</b>
<b>! CAUTION !</b>

The **LOW** pressure cut-in should be set at 40 psig and the cutout set at 20 psig for R-22

The **LOW** pressure cut-in should be set at 52 psig and the cutout set at 28 psig for R-404a.

After tripping at the cutout setting, the switch will reset automatically when the pressure rises to the cut-in setting.

The **HIGH** pressure cutout should be set at 300 psig for R-22 and 350 psig for R-404a. After tripping, reset the switch manually.



**FIGURE 9-4**  
**High-Low Pressure Switch**

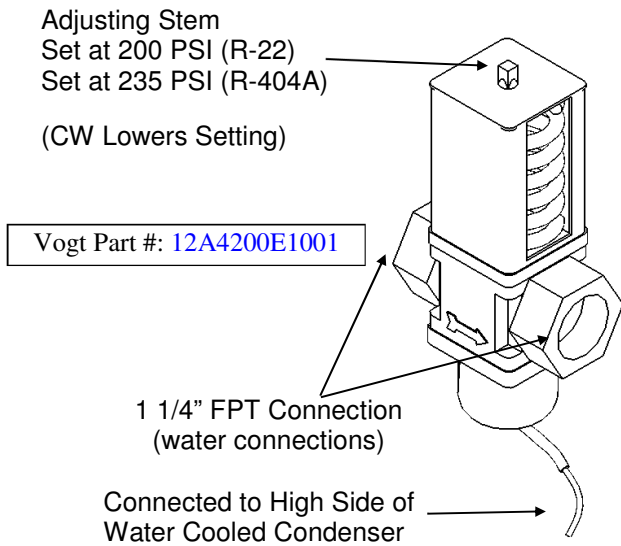
If it becomes necessary to install a new high/low pressure switch, the following procedure is recommended for its adjustment:

Turn the adjusting screws clockwise to raise the pressure setting. Turn counter-clockwise to lower the setting. Adjust the switch to the indicated pressure settings and test with an accurate gage to be sure the switch functions properly before installation.

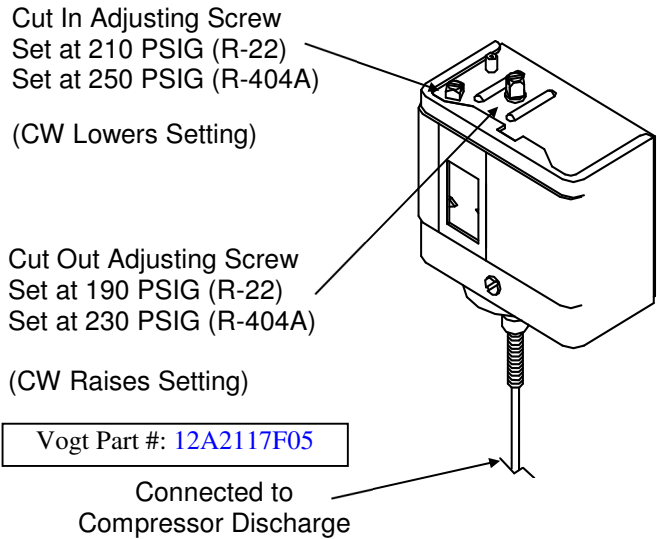
**Head Pressure.** The head pressure should be maintained at 190-210 psig for R-22 and 230-250 psig for R-404a during the freeze cycle. This pressure can be checked at the test connection in the high pressure line near the high-low pressure switch.

**Water-Cooled Units.** A water regulating valve (FIGURE 9-5A) located in the condenser water inlet line is used to control the water flow through the condenser. This valve should be adjusted to maintain a head pressure of 195 psig for R-22 and 235 psig for R-404a. Increasing the water flow lowers the head pressure and decreasing the water flow raises the head pressure. The valve is adjusted during the factory test. The valve stem should not be opened as far as it will go or the valve will not close fully when the head pressure drops below its setting.

**Air-Cooled Units.** The condenser fan switch mounted to the frame (lower right side) (FIGURE 9-5B) (CPS) is used to regulate the head pressure. This is an adjustable pressure switch located on the right-hand front of machine. It controls the operation of the condenser fan motor(s) through a contactor (FC) (FIGURE 6-2) located in the control panel. The switch is set to cycle the fan motor(s) “On” at 210 psig and “Off” at 190 psig for R-22 and “On” at 250 psig and “Off” at 230 psig for R-404a. Higher settings may be necessary for 0°F and below ambient conditions to assure there is enough warm gas for ice harvesting.

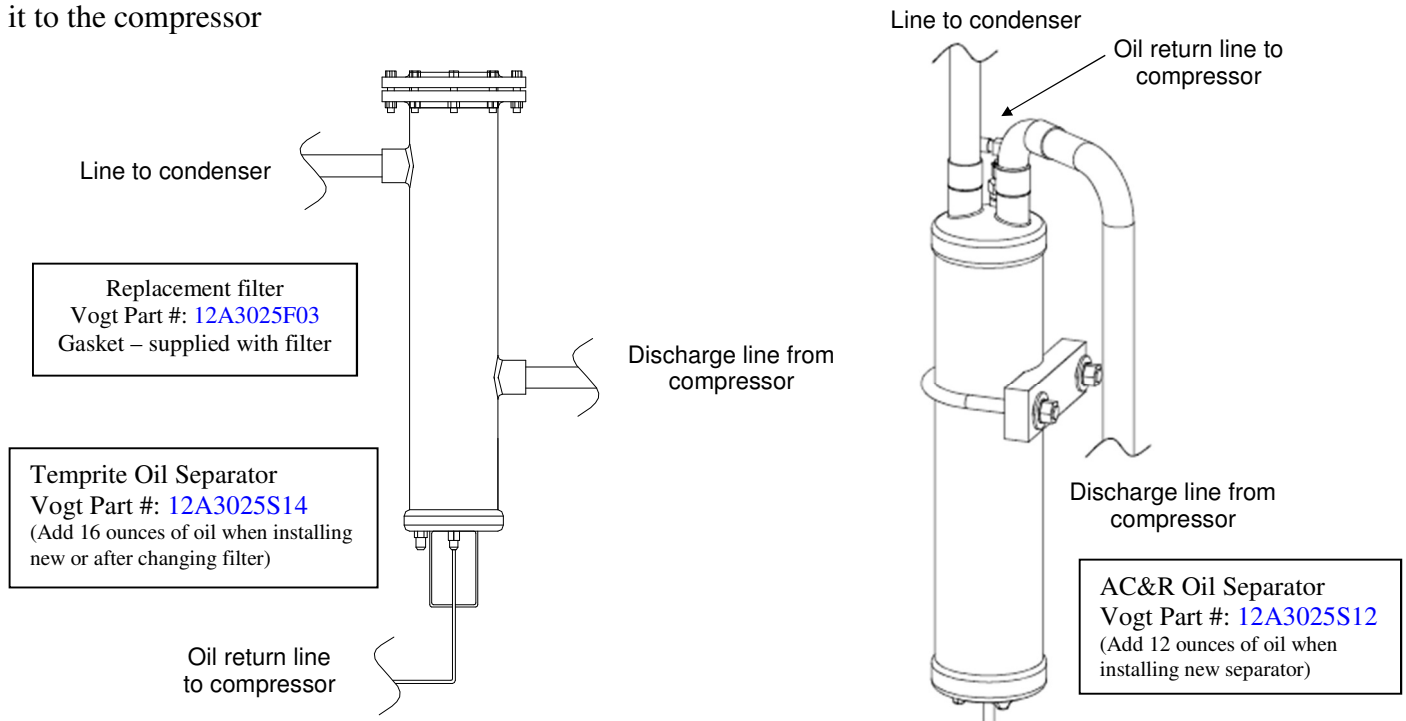


**FIGURE 9-5A.**  
**Water Regulating Valve**



**FIGURE 9-5B.**  
**Condenser Fan Switch**

**Oil Separator.** A coalescent oil separator is used to separate the oil from the discharge gas and return it to the compressor



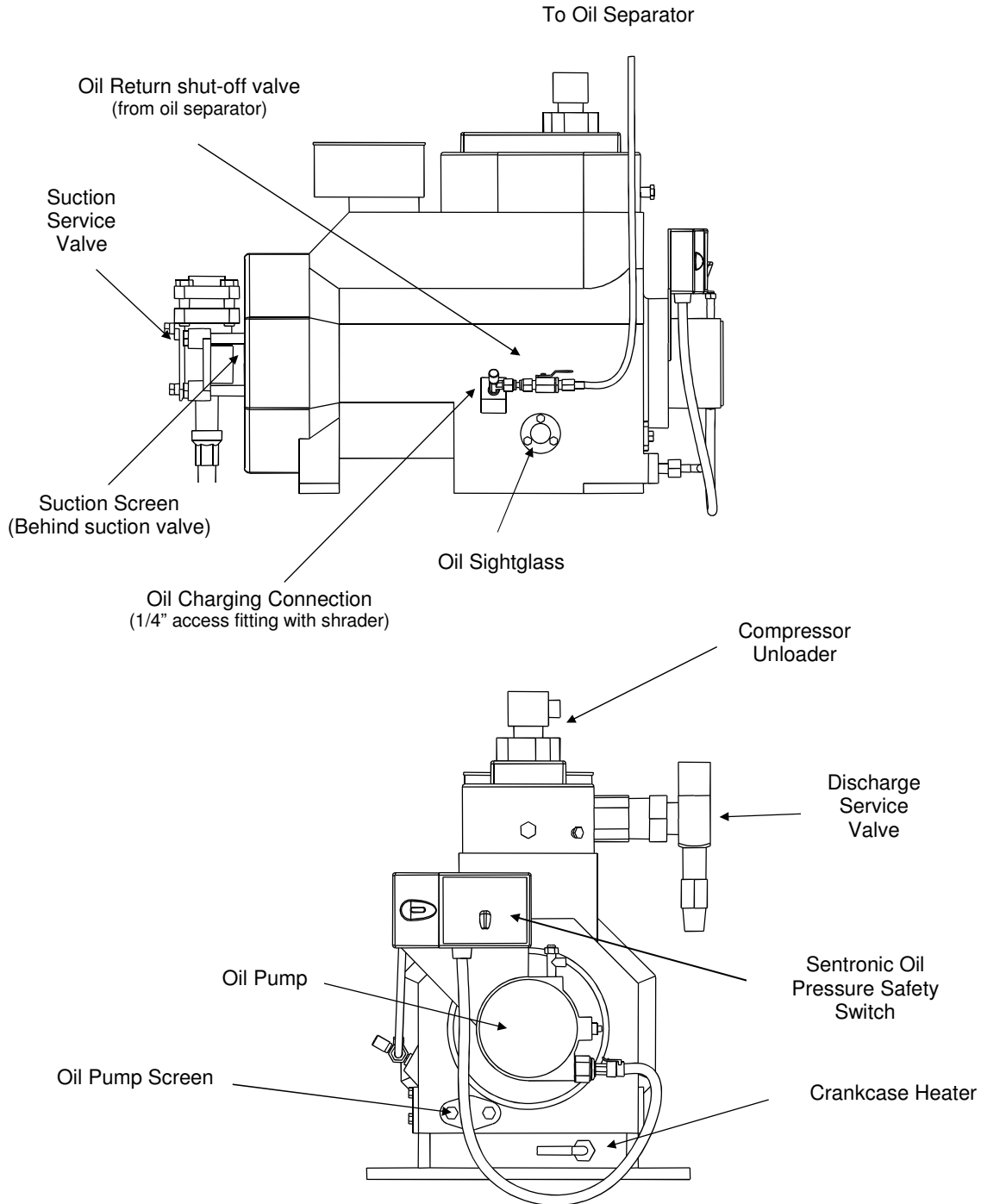
**FIGURE 9-6**  
**Oil Separator**



**Compressor Crankcase Heater.**

Vogt Part #: [12A7509E12](#)

When electrical power is supplied to terminals L1, L2 & L3 of the control panel, the crankcase heater is energized when the machine is not operating. It is de-energized when the compressor is operating.



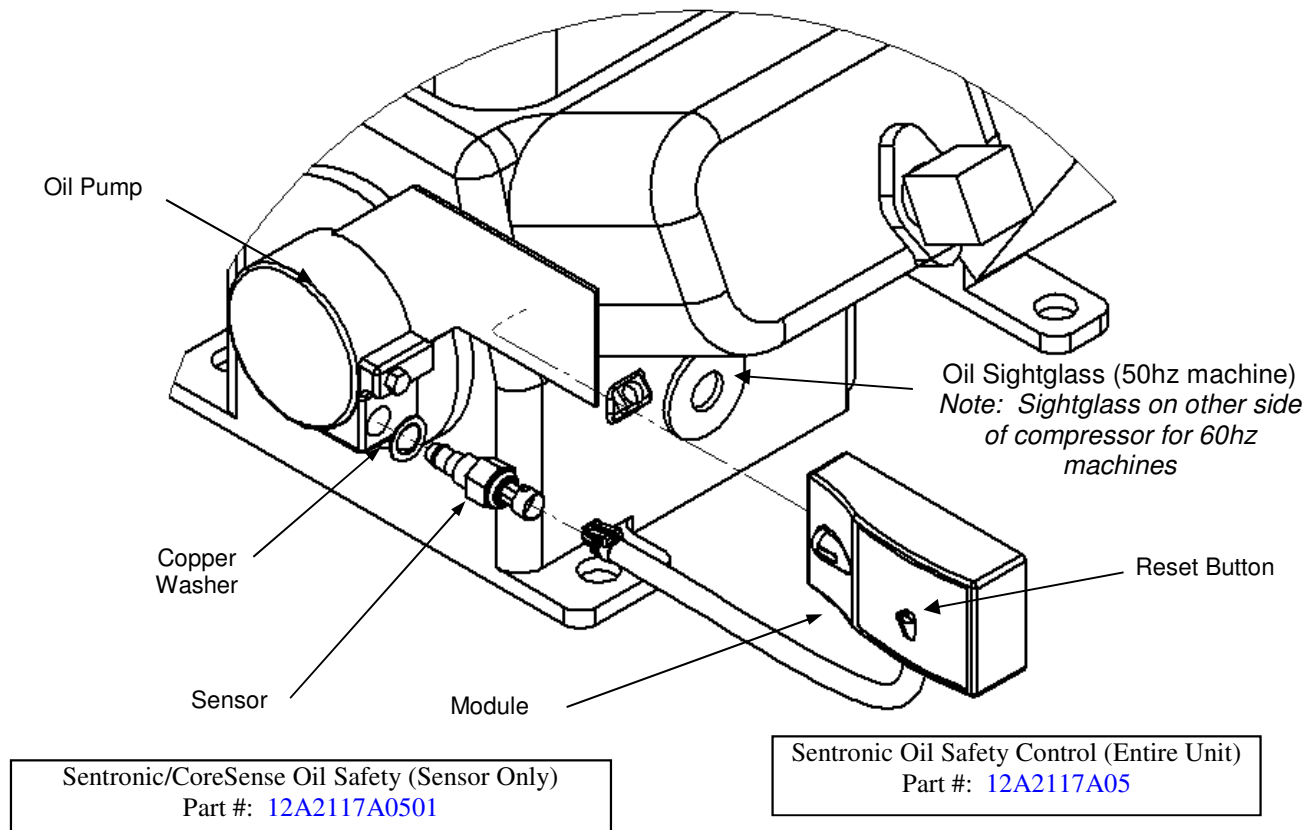
**FIGURE 9-8  
Copeland Discus Compressor (3D shown)**

## SERVICE OPERATIONS

**Sentronic Oil Pressure Safety Control.** All Sentronics utilize a pressure sensor and an electronic control module to precisely measure oil pump differential pressure. The main advantage of Sentronic is the elimination of the traditional capillary tubes, bellows, and pressure connections that mechanical pressure switches require to measure differential oil pressure. These require careful handling and are known to be a source of leaks in refrigeration systems.

A second advantage of Sentronic is in the use of a precise electronic clock for the two minute time out circuit. Traditional mechanical controls use resistance heaters to provide the time to trip in the event of low oil pressure. 208 volt systems, low ambient temperatures or brown-out type conditions cause the heater output to be reduced, thus increasing the time out period from two minutes to three or four minutes when low oil pressure conditions exist. With the electronic clock, the time out will always be the same.

As a result of the elimination of the capillary tube measuring system and a more precise timing circuit, Sentronic will improve the overall reliability of the refrigeration system. As in the past, all new and replacement Copelametic compressors equipped with oil pumps require the use of a Copeland approved oil pressure safety switch. Failure to use an approved oil pressure safety switch will be considered as misuse of the compressor, and can adversely affect warranty replacement of the compressor should a lubrication connected failure occur.



**FIGURE 9-9A**  
**Sentronic Oil Pressure Safety Control**

**Sentronic Sensor** (2D, 3D, 4D & 6D compressors before March 2011). The same oil pressure sensor is used for all Sentronics. It mounts directly into the oil pump. The Sentronic sensor measures oil pump differential pressure. It has an internal contact that opens on low oil pressure and signals the Sentronic electronic control module to begin time out. The same contact closes when proper oil pressure is present and stops the module time out. Should oil pressure fall below 7-9 PSID for a period of two minutes, the Sentronic module will open the control circuit, using its Normally-Closed (N) contact, and shut the compressor off.

Approximate oil pressure can be measured in the field. Oil pumps are furnished with a Schrader valve mounted on the oil pump discharge port. To measure oil pressure, subtract crankcase pressure from discharge oil pressure. Tripping of the oil pressure safety switch is a warning that the system has been without proper lubrication for too long a time. Repeated trips of the oil pressure safety control are a clear indication that something in the system requires immediate remedial action.

**Sentronic Module** (2D, 3D, 4D & 6D compressors before March 2011). The Sentronic has in addition to the (N) contact, used for compressor shutdown, a Normally Open (N.O.) contact that can be used in an alarm circuit. The Single Pole Double Throw (S.P.D.T.) contact of Sentronic can be electrically isolated from the control circuit power supply, and used to control a circuit with a different voltage. Sentronic has a timing circuit that actually compares the amount of time with good oil pressure to that with insufficient oil pressure and has a memory that will shut the compressor down after a period of more than two minutes if the compressor has a "history" of oil pressure fluctuations with more unacceptable than acceptable pressures.

Sentronic also has a memory that retains the compressor oil pressure "history" for up to one minute in the event of a power loss. Sentronic uses a permanent magnet integral with the reset button to reset its output control relay in the event of a trip. When the reset button is depressed, it magnetically pulls the Sentronic relay's armature to its original, reset position. Sentronic needs no voltage present to reset.

### **CoreSense Protection**

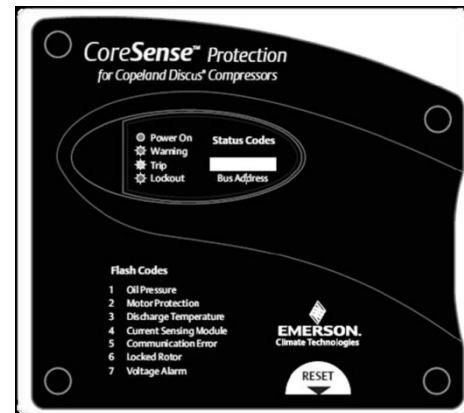
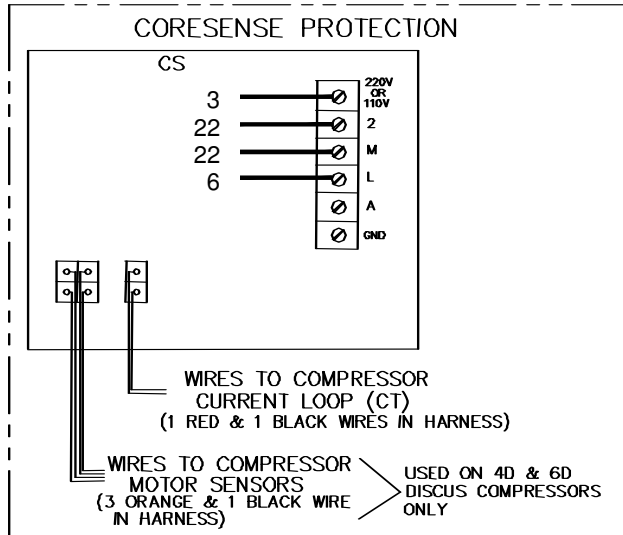
Discus compressors manufactured after March 2011 will be supplied with CoreSense Protection. CoreSense replaces the Sentronic Oil Pressure Safety Module on all Discus compressors and the Electronic Motor Protector Module on 4D & 6D compressors. Note: 2D & 3D compressors will continue to have Internal Line Break overload protection.

The oil pressure monitoring portion of the CoreSense will act very similar to the Sentronic Oil Pressure Safety switch. A current transformer (CT) in the compressor junction box determines when the compressor is running and starts monitoring oil pressure. Note: Wire "T1" passes through CT before connecting to compressor terminal.

SERVICE OPERATIONS

The CoreSense module has power applied at all times to allow for more detailed fault notification. An LED will flash when a fault occurs. The number of flashes will identify the fault condition.

# of Flashes	Condition
1	Oil Pressure
2	Motor Protection Trip
3	Discharge Temperature (optional add-on)
4	Current Sensor Fault
5	Communication Error



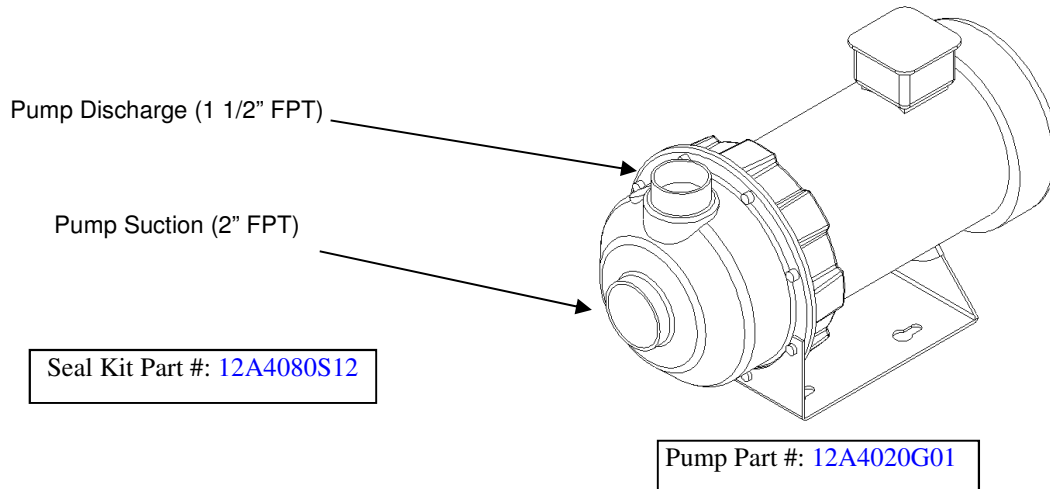
**FIGURE 9-9B**  
**CoreSense Protection**

Description		Vogt #	Copeland #
Crankcase Heater	100 W (insert type)	12A7509E12	518-0028-01
Oil Pressure safety switch	Sentronic3 Module and Sensor	12A2117A05	585-1076-02
CoreSense Protection	Module and Sensor	12A2117A07	943-0109-00
Oil safety – sensor only	For Sentronic, Sentronic 3 or CoreSense	12A2117A0501	998-0162-00

**Control Circuit Protection.** The electrical control circuit of the machine is protected by a 2 pole 3 amp circuit breaker. If breaker trips, the machine will immediately stop. Before resetting the breaker, open the disconnect switch to machine and set the “Ice/Off/Clean” switch to the “Off” position. If the machine was off for an extended time the crankcase heater must be energized for a minimum of two hours before restarting the machine. When ready to restart the machine, depress the “Start” button. The machine will automatically return to a freeze cycle upon completion of the harvest cycle.

**Circulating Water Pump Motor.** The motor bearings are prelubricated and sealed. They require no further lubrication. The pump should operate with the water level above the impeller housing.

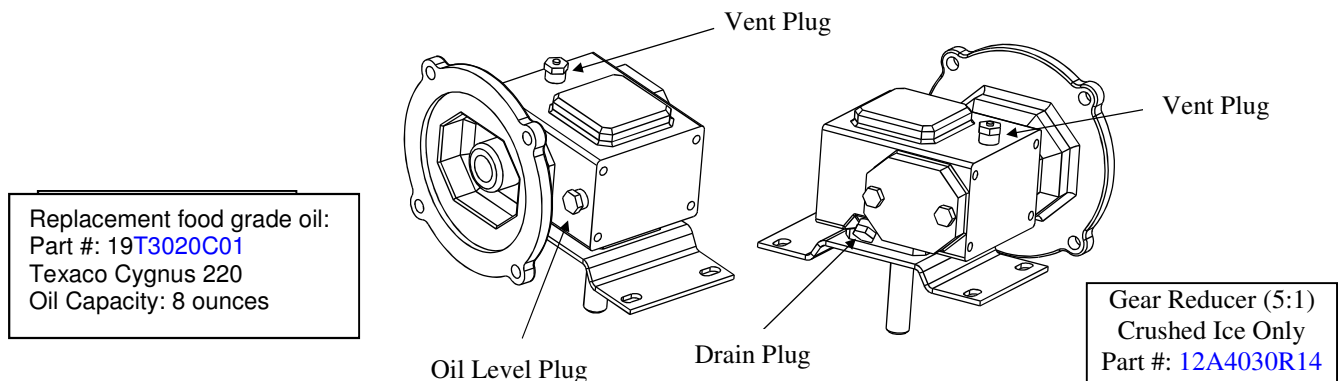
The pump is equipped with a mechanical seal that is self-adjusting and requires no lubrication. However, the pump should not be operated unless circulating water. The pump manufacturer recommends that a mechanical seal be kept as a spare. When ordering a seal, specify pump size, type, serial number, and manufacturer's name as indicated on the nameplate.



**FIGURE 9-10**  
**Water Pump**

**Cutter Gear Reducer.** The oil level for the gear reducer should be checked if there is evidence of a leak. It should be level with the plugged opening in the side of the gear housing. Use Mobile 600W cylinder oil or equal. Change oil once a year.

The motor bearings are prelubricated and require no further lubrication. For additional information, refer to manufacturer's instructions.

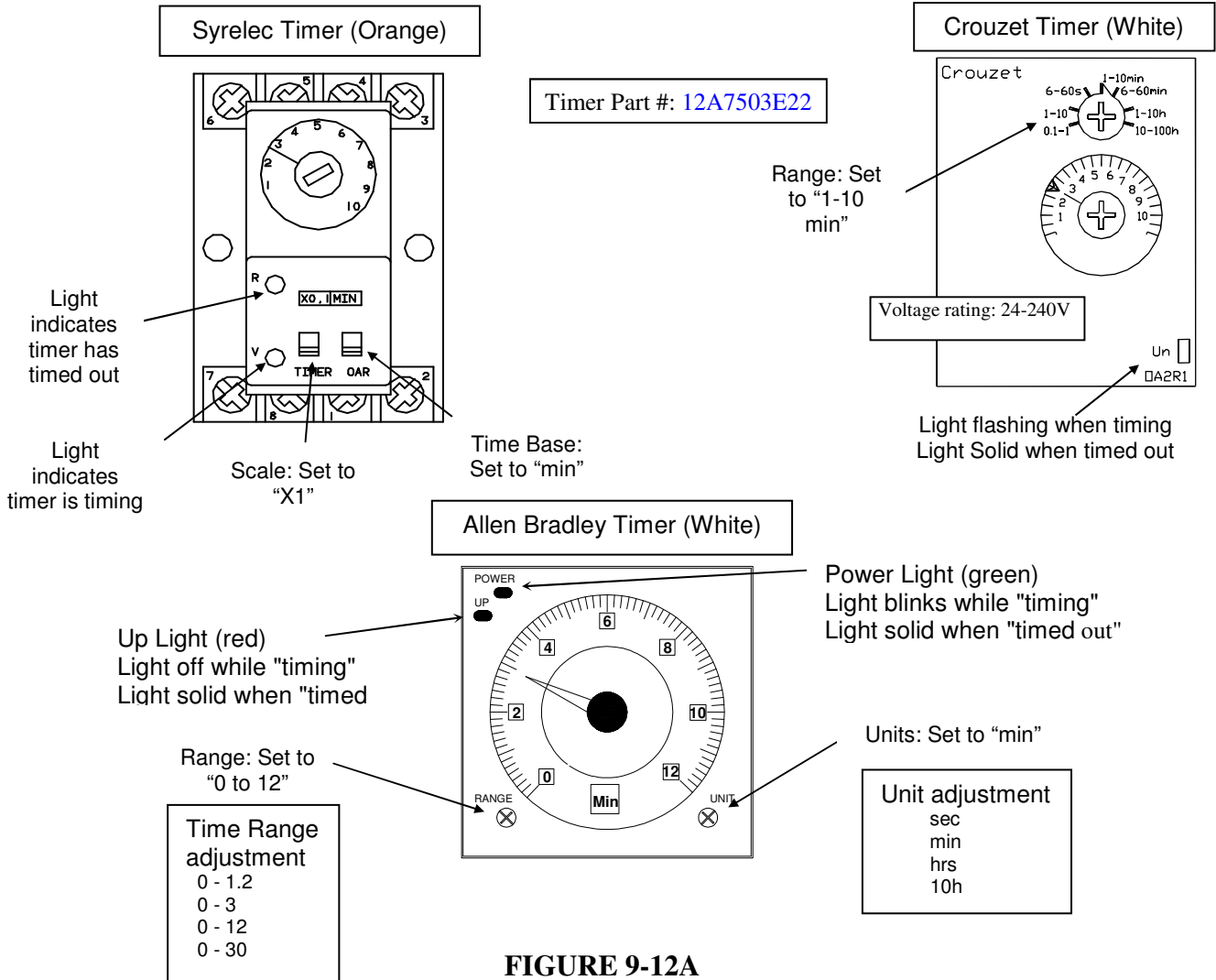


Note: Ventless gear reducer used after August 2010

**FIGURE 9-11**  
**Gear Reducer**

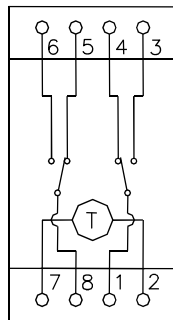
SERVICE OPERATIONS

**Thawing Timer.** The thawing timer governs the ice thawing period. It is located inside the control panel (FIGURE 6-2). It is started by action of the freezer pressure switch (FPS) which energizes the “CR” relay. This timer is set prior to shipment for approximately a two minute period.



**FIGURE 9-12A**  
**Thawing Timer**

Set the thawing period for at least 30 seconds longer than the time required to harvest the entire discharge of ice. If it should be necessary to change the setting of the timer, turn the adjustment screw clockwise to increase the time or counter-clockwise to decrease the time. Check thaw time after each adjustment.



**FIGURE 9-12B**  
**Thawing Timer Wiring**

**Condenser Cleaning.** See “Water Cooled Condensers”, “Maintenance”, Section 7.

**Air-Cooled Condenser.** Visual inspection will indicate if dirt is accumulating and clogging the fin face of the condenser. A vacuum cleaner, compressor air or a brush may be used to remove any accumulation of dirt from the fin section of the condenser.

**Pumpdown.** The function of the pumpdown is to transfer all of the liquid refrigerant from the freezer (evaporator) into the receiver. Pump-down should only be performed when the freezer is clear of ice. Its main purposes are:

1. Before Cleaning machine
2. To check the total refrigerant charge.
3. To perform service or repair work on the machine.
4. To winterize the machine.
5. To prepare the machine for disconnecting and moving.

To perform a pumpdown, follow this procedure:

1. Push manual harvest button to clear the freezer of all ice and stop operation.
2. Close the liquid stop valve (58) at the receiver.
3. Open the water tank drain valve (39) partially to allow a continuous flow of warm make-up water into the water tank, and still maintain a good level in the tank. An auxiliary supply of warm water (not to exceed 100°F) may be used if available. Warmer water affords a more complete pumpdown.
4. Start the machine and allow it to operate and complete one harvest
5. During the thaw cycle, close the 1/4" valve going to the freezer pressure switch to prevent another thaw cycle.
6. Allow the machine to operate until the low pressure switch stops the machine @ 20 PSIG. If a lower pressure is desired, it can be accomplished by lowering the low pressure switch and starting and stopping the machine by the "Start" and "Stop" push buttons. Continually observe the oil level to make sure the oil is not carried from the compressor while operating at a low pressure.
7. Close the thawing gas stop valve (90), the receiver liquid return stop valve (91), the compressor suction valve (34), the compressor discharge valve and the oil return stop valve (70).

## SERVICE OPERATIONS

**Removal Of Refrigerant From The Machine.** To transfer the refrigerant charge from the machine into a separate container, proceed as instructed above under “Pumpdown”. This will isolate most of the refrigerant in the receiver and the recovery unit can be connected to the access port (44) of the hand stop valve (58) at the bottom of the receiver. Open the valve access port by turning the valve stem in (front seat) and operate the recovery unit until the system is considered empty.

<b>! WARNING !</b>
<b>Approved recovery equipment, hoses, gages, and refrigerant containers must be used to comply with all local and federal EPA regulations.</b>
<b>! WARNING !</b>

<b>! WARNING !</b>
<b>Follow these instructions carefully. Severe personal injury can result from improper discharge of refrigerant.</b>
<b>! WARNING !</b>

<b>! WARNING !</b>
<b>It is not recommended that refrigerant be transferred from a refrigeration system into a cylinder. If such a transfer is made, the refrigerant cylinder must be an approved CLEAN cylinder -- free of any contaminants or foreign materials--and must be weighed continuously to assure contents do not exceed net weight specified by cylinder manufacturer or any applicable code requirements.</b>
<b>! WARNING !</b>

**Refrigerant Leaks.** In addition to testing the machine for leaks as instructed under “Refrigerant Charge”, it is advisable to again make a leak test after the unit has been in operation approximately one week. Any noticeable change in operating conditions, other than shown on the “Certificate of Test” may indicate a loss of refrigerant due to a leak. Always remove the refrigerant pressure from the vessel or tubing before repairs are attempted.

**Non-condensable Gases.** Satisfactory operation of the machine is not possible if non-condensable gases (usually air) are present in the system. Excessive condensing pressure is an indication of such gases. Excessive condensing pressure in water cooled condensers may also be due to the accumulation of scale in the cooling coil or due to insufficient cooling water or excessive water temperature. See “Water Cooled Condensers”, Section 7.

**Compressor Motor Burnout.** There are several causes of compressor motor burnout. Some of these are described below.

1. **Low line voltage.** A compressor motor is designed to operate within the range of plus or minus 10% of its nameplate voltage. Low voltage requires the motor windings to carry more current at the same compressor load. When this current gets too high or is applied for an extended period, the motor windings overheat, resulting in a failure or burnout.
2. **Loss of refrigerant.** The hermetic compressor motor is maintained at proper operating temperature by passing cool suction gas over the motor windings. A loss of refrigerant can cause the winding to overheat resulting in a failure or burnout.
3. **High head pressure.** The system is designed to operate at 200 psig. Excessive head pressure adds refrigerating load on the compressor, which can cause the windings to overheat and result in a failure or burnout.
4. **Moisture.** Moisture in contact with refrigerant oil and the presence of heat will form hydrochloric or hydrofluoric acid. The acid will destroy the insulation on the motor winding causing a short circuit, which can increase motor temperature in excess of 3000°F. This extreme temperature will also create a sludge or black residue in the system.
5. **Mechanical failure.** Mechanical failure has been determined as a major cause of motor burnout. Bearing wear or wipe-out may allow rotor to drag--overheating the windings and burnout.

Whenever there is a compressor failure due to a motor burnout, it is important that the system be thoroughly cleaned before replacing the damaged compressor or otherwise the new compressor may also be damaged.

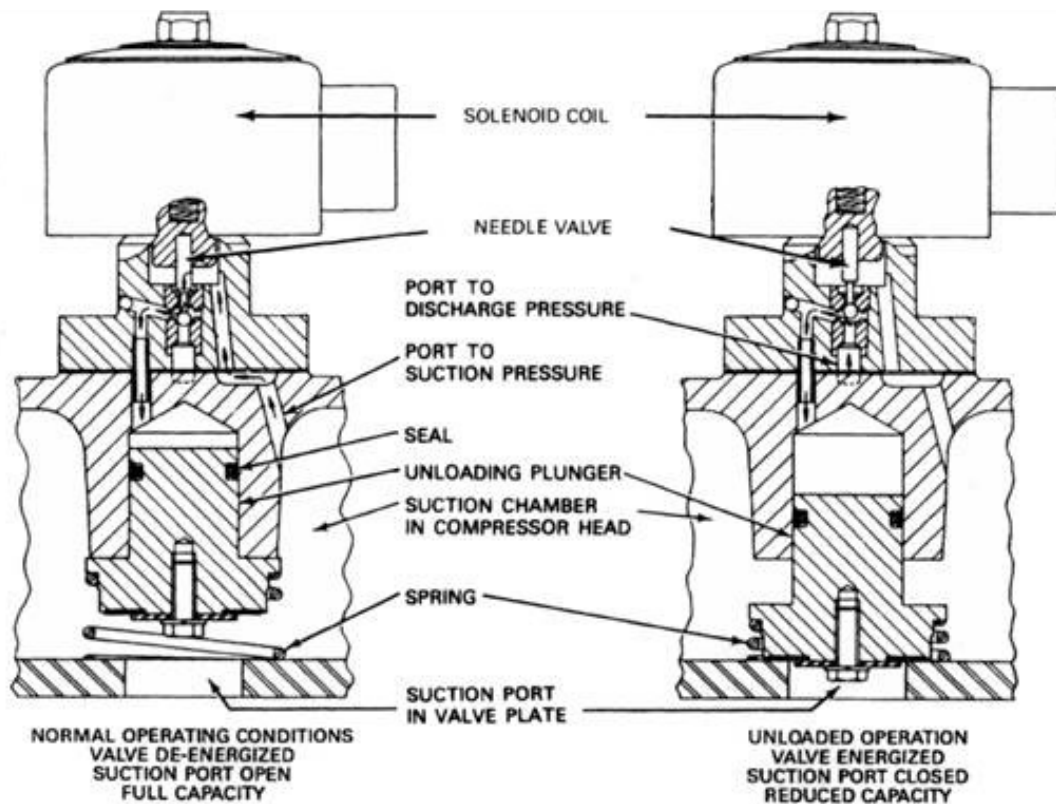
## SERVICE OPERATIONS

**Capacity Control (Internal) Valve Construction.** A schematic illustration of the internal valve operation is shown in FIGURE 9-13.

In the normal (full capacity) operating position with the solenoid valve de-energized, the needle valve is seated on the lower port, and the unloading plunger chamber is exposed to suction pressure through the suction port. Since the face of the plunger is open to the suction chamber, the gas pressures across the plunger are equalized, and the plunger is held in the open position by the spring.

When the solenoid valve is energized, the needle valve is seated on the upper port, and the unloading plunger chamber is exposed to discharge pressure through the discharge pressure port. The differential between discharge and suction pressure forces the plunger down, sealing the suction port in the valve plate, thus preventing the entrance of suction vapor into the unloaded cylinders.

The seal on the unloading plunger minimizes any leakage in pressure so that a pumpdown cycle may be used with the valve either energized or de-energized without excessive compressor cycling.



**SCHEMATIC OPERATION OF INTERNAL UNLOADER VALVE**

**FIGURE 9-13**

**Loaded Operation (during freeze).** This capacity control valve is controlled by an electric solenoid. When the solenoid is de-energized, the valve loads the cylinder bank (2 cylinders) as shown in the above figure.

**Unloaded Operation (during thaw only).** During the thaw cycle, the solenoid coil is energized. The needle valve is seated on the upper port, and the unloading plunger chamber is exposed to discharge pressure through the discharge pressure port. The differential between discharge and suction pressure forces the plunger down, sealing the suction port in the valve plate, thus preventing the entrance of suction vapor into the unloaded cylinders.

## **Component Removal and Replacement Operations**

**Cutter Motor** The cutter motor's bearings are prelubricated and sealed and require no further lubrication. If the motor needs replacing, proceed as follows:

1. Turn power off and lockout disconnect.
2. Check terminals with voltmeter to confirm power is off.
3. Remove motor terminal cover and disconnect wires. Mark wires for ease of replacement.
4. Remove four cap screws around the motor flange and separate the motor from the reducer. Watch for shaft key that must be reinstalled later.
5. Check the motor electrically to confirm it is defective.
6. Apply Anti-Seize lubricant to the shaft of the replacement motor.
7. Position the shaft key in the motor keyway, align it with the reducer keyway and install the motor. Make sure the key stays in position as shaft is.
8. Install the four cap screws to hold the motor in place on the reducer.
9. Connect the wires and install the terminal cover.
10. Check motor rotation to make sure the cutter turns in the proper direction. Reverse two wires at the motor if necessary to change rotation direction.

**Cutter Gear Reducer** To remove the gear reducer, proceed as follows: (See FIGURE 9-11)

1. Turn power off and lockout disconnect.
2. Remove motor from reducer.
3. Loosen (slightly) the four bolts and nuts holding the gear reducer in place.
4. Remove the four bolts holding the mounting plate to the water tank gear enclosure and remove the reducer and mounting plate from the tank.
5. Measure the distance between the top of drive gear and the mounting plate for future reference.
6. Remove the three cap screws from the gear and hub and install two 1/4"-20 x 2" long all thread set or cap screws in the threaded holes of the drive gear. These two screws can be used as jacking bolts to remove the gear from the tapered split hub.
7. In necessary, driving a screwdriver in the split and sliding the hub off the shaft can remove the split hub.
8. The new gear reducer can then be installed by reversing the removal procedure.
9. Be sure the gear and hub is properly positioned on the shaft so it will have a full vertical mesh with the cutter ring gear.
10. Final gear meshing should be adjusted so there is only a slight amount of play between the ring gear and drive.
11. Make sure all bolts are tightened securely and there is no excessive gear noise when the cutter motor is running.

## SERVICE OPERATIONS

**Water Tank Removal**

1. Turn off and lock out power to the machine.
2. Turn off water supply and disconnect lines from the tank.
3. Drain the tank and disconnect pump suction tube and drain line tubing and water lines.
4. Disconnect the ice discharge chute.
5. Loosen bolts holding the tank to the cutter assembly until the tank rests on the bars.
6. Loosen bolts holding the tank supports.
7. The tank can then be removed to the side of the machine.
8. Make sure the rubber gasket is in place and aligned properly when the tank is installed and bolted to the freezer.

**Cutter and Bearing Removal/Installation**

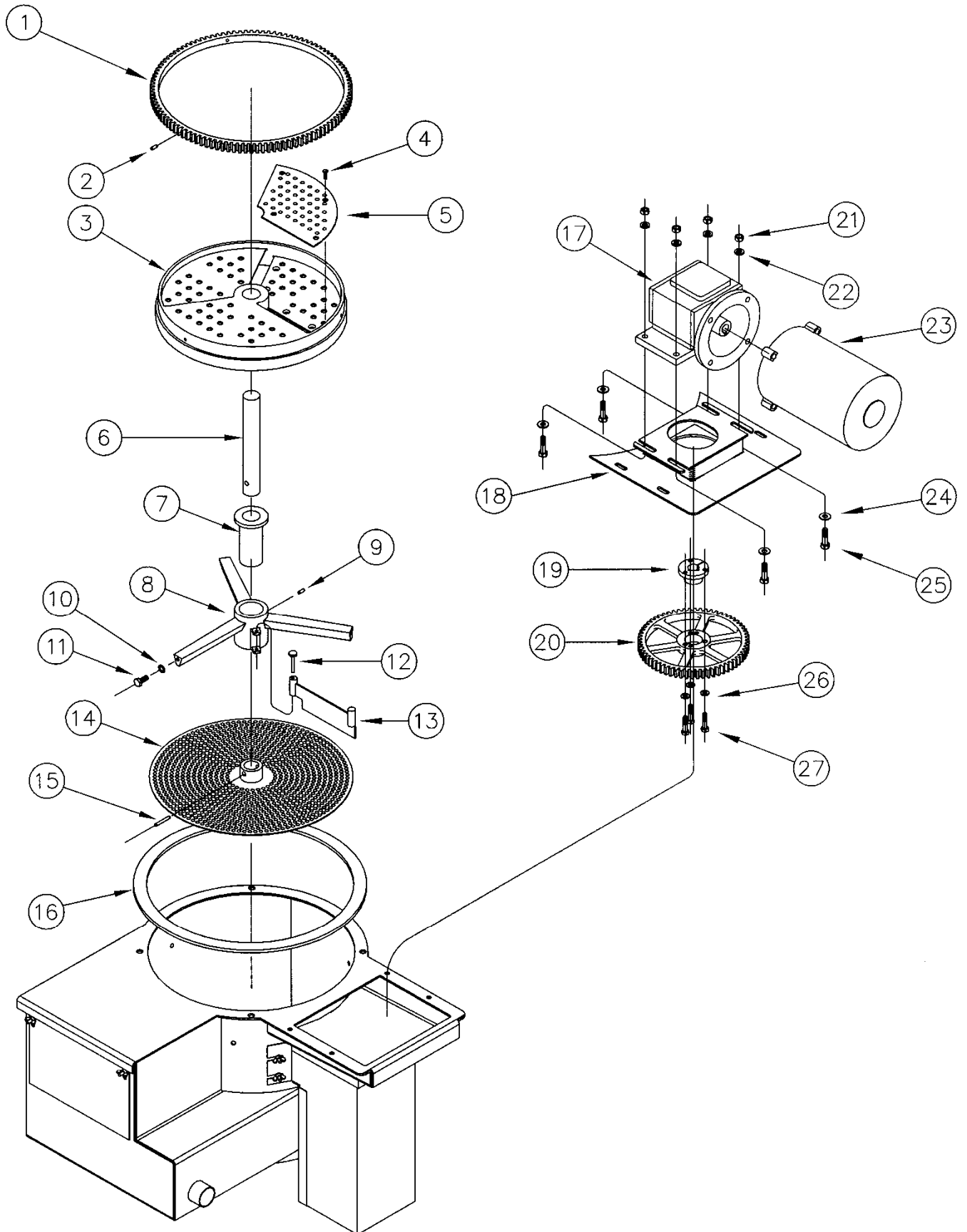
Refer to FIGURES 9-14 for parts identification and location.

1. Turn off and lock out power to the machine.
2. Remove the cutter motor from the reducer.
3. Remove the water tank assembly and then the cutter assembly.
4. With a 1/4" or slightly smaller punch, reach in through the ice discharge opening, drive the spiral pin out of the disc hub and cutter shaft, and push or drive the disc off the shaft.
5. Lift the cutter assembly out of the bearing surface of the cutter. The surface should be smooth and free from nicks or burrs.
6. Inspect the bearing for wear. There should be no side movement between the shaft and bearing and the bearing thrust flange should be no thinner than 3/16" (it is 1/4" thickness new).
7. Before removing the bearing, reference mark the location of the bearing support on the side of the tank.
8. Loosen and remove the three cap screws from the bearing support ends and lift the support out of the water tank.
9. Drive the 3/16" x 1/2" pin located in the side of the support hub in and through the bearing wall.
10. Now the bearing can be pressed or driven out of the support hub.
11. Try the new bearing on the cutter shaft to make sure it turns easily.
12. Press or drive the new bearing into the hub. Be careful not damage the bearing surfaces (the old bearing may be used as a driver).
13. Drill a 3/16" hole through the bearing wall, using the original hub hole as a pilot. Insert and drive the 3/16" pin flush with the outside of the hub, making sure the pin doesn't extend beyond the inner surface of the bearing.
14. Slide the new bearing and support onto the cutter shaft to make sure it spins freely. If it is tight, ream the bearing inner surface slightly until it turns free.
15. Install the bearing support in the tank, using the reference marks as a guide.
16. Slide the cutter and shaft into the bearing and check the cutter alignment. By laying a straight edge across the tank top flange, there should be 0" to 1/16" clearance between the rim of the cutter and the top of the tank flange. Loosen the bearing support cap screws and drive the support arms up or down for the proper alignment.
17. Tighten the support screws securely and finish assembly of the cutter and cutter disc.
18. Install the tank and other parts, reversing the procedure of removal.

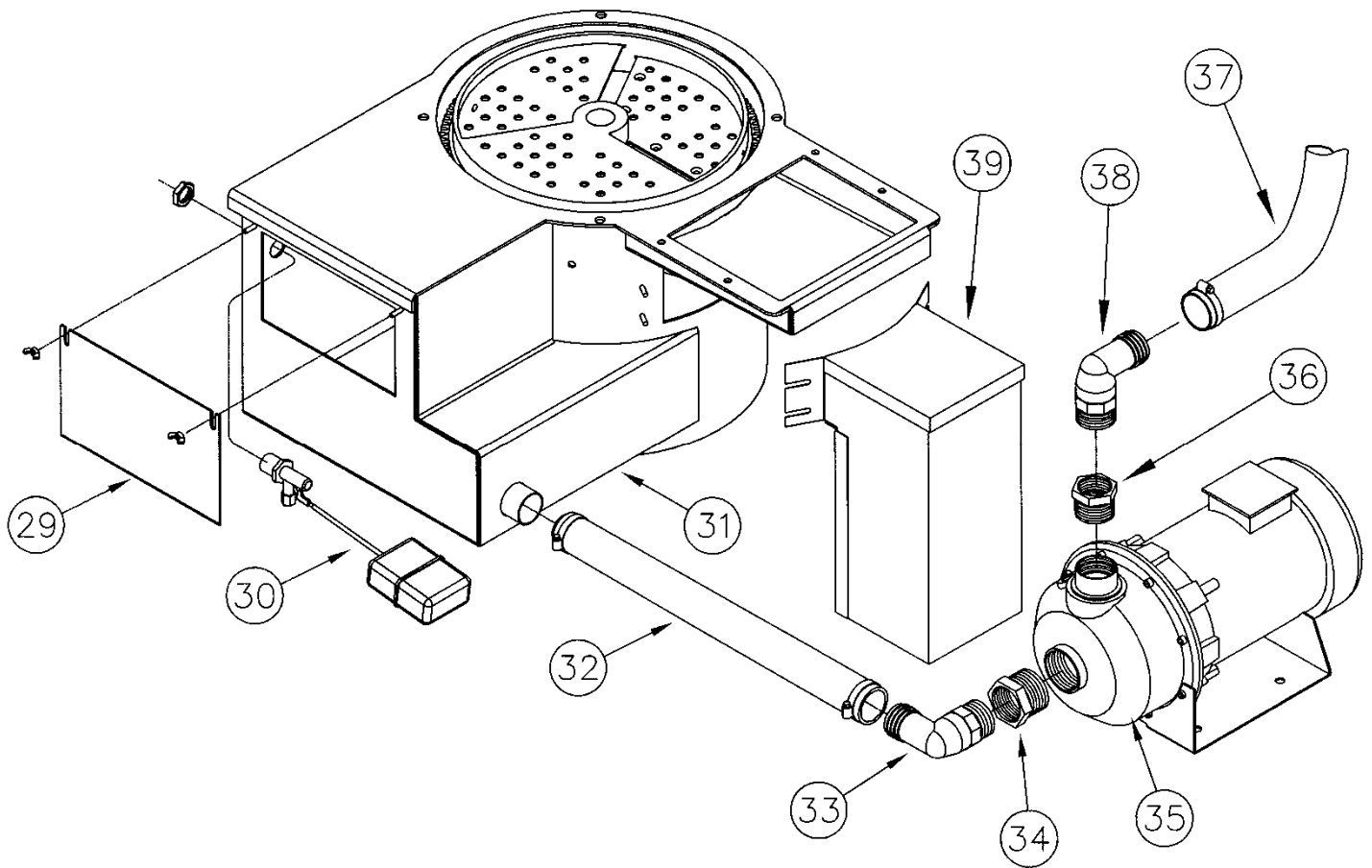
Item No.	Vogt Part Number	Description
1	N/A	Cutter Ring Gear – part of cutter casting
2	<a href="#">12A3040S02</a>	Spring Pin
3	<a href="#">19T2160C0101</a>	Cast Cutter
4	<a href="#">12A2226F1108</a>	1/4" Flat Head Screw
5	<a href="#">19T2010A01</a>	Cutter Adapter Plate
6	<a href="#">19T4090S01</a>	Cutter Shaft
7	<a href="#">12B2020R04</a>	UHMW Cutter Bearing
8	<a href="#">19T2025B0103</a>	Bearing Support
9	<a href="#">12A3040S02</a>	Spring Pin
10	<a href="#">12A2250A1070</a>	1/4" Cut Washer
11	<a href="#">12A2215F1206</a>	1/4" Cap Screw
12	<a href="#">12A4071S03</a>	Rivet For Ice Deflector
13	<a href="#">19T2170D01</a>	Ice Deflector
14	<a href="#">19T2163D0101</a>	Cutter Disc Assembly
15	<a href="#">12A3040S01</a>	Spirol Pin
16	<a href="#">12A2600G12</a>	Water Tank Gasket
17	<a href="#">12A4030R12</a>	Gear Reducer
18	<a href="#">12B2165M0101</a>	Gear Reducer Mounting Bracket
19	<a href="#">12A2160H0101</a>	Gear Hub
20	<a href="#">19T2615D01</a>	Drive Gear
21	<a href="#">12A2240A1108</a>	5/16" Hex Nut
22	<a href="#">12A2250B108</a>	5/16" Lockwasher
23	<a href="#">12A2900M0508</a>	Motor, 1/2 Hp, 208/230/460-3-50/60 Hz
24	<a href="#">12A2250A108</a>	5/16" Cut Washer
25	<a href="#">12A2215G1108</a>	5/16" X 3/4" Hex Head Cap Screw
26	<a href="#">12A2250B107</a>	1/4" Lockwasher
27	<a href="#">12A2215F1112</a>	1/4" Hex Head Cap Screw
29	<a href="#">19T1501S0505</a>	Float Box Cover Assembly
30	<a href="#">12A4200H0401</a>	Roberts NSF approved Float Valve, 1/2"
31	<a href="#">19T4500S112</a>	Water Tank Assembly
32	<a href="#">12A4181T07</a>	1 1/4" I.D. Tygon Tubing
33	<a href="#">12A2450E17</a>	Elbow, 1 1/4" MPT X Insert
34	<a href="#">12A2450B12</a>	2" X 1 1/4" Bushing
35	<a href="#">12A4020G01</a>	Water Pump, Gould NPE-3ST
36	<a href="#">12A2450B02</a>	Bushing 1 1/2" X 1 1/4"
37	<a href="#">12A4181T06</a>	1 1/4" I.D. Tygon Tubing
38	<a href="#">12A2450E17</a>	Elbow, 1 1/4" MPT X Insert
39	<a href="#">19T2090C07</a>	Ice Chute Assembly

**Table 9-1  
Cutter/Tank Assembly Nomenclature**

SERVICE OPERATIONS



**FIGURE 9-14**  
**Cutter, Water Tank and Drive Gear Assembly**



**FIGURE 9-15**  
**Water Tank and Pump Assembly**

**Crushed Ice Production** Your 03TA Tube-Ice<sup>®</sup> machine is capable of producing crushed ice with no loss of capacity. However, there are certain changes to be made in order to convert to crushed ice production.

**Modifications Required:**

1. Reverse cutter direction by switching 2 of the 3 leads at the cutter motor (connections 52, 53 and 54).
2. Set the freezer pressure switch at 38 psi to make ice 3/16" thick (average). The freezer harvest pressure may need to be adjusted by  $\pm 1-3$  psi to get the required thickness of ice.

This conversion process should normally be accomplished by two people in 1-2 hours (or less). It is recommended that you have good quality water when attempting to produce crushed ice. If the ice is opaque and cloudy, the cutter mechanism may become clogged, restrict ice discharge and bind the cutter. In addition, you should not attempt to produce crushed ice when the make-up water temperature is below 50°F (10°C). Colder water can cause a build-up of ice fines in the tank and eventually result in "short-cycling" which can damage the compressor.

Complete detailed instruction for converting to crushed ice production can be obtained through your distributor.

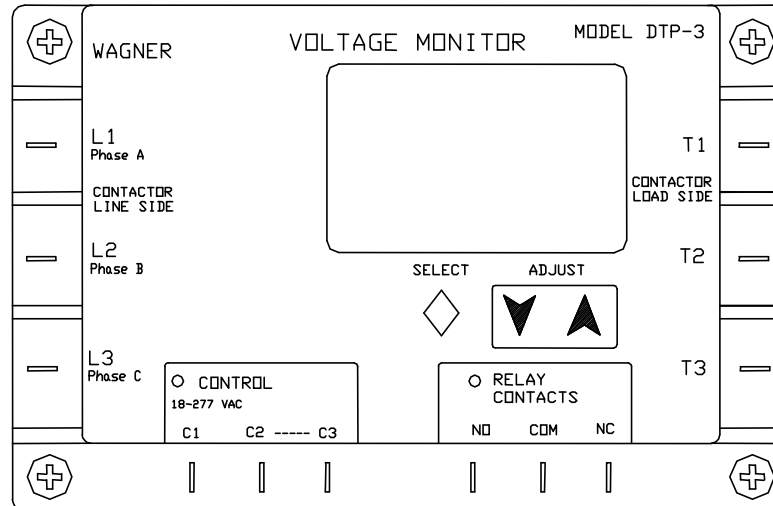
Blank page

## 10. Options and Accessories

### Power Monitor

#### Wagner Model #: DTP-3

All Vogt Tube-Ice machine models are available from the factory with a three phase line voltage power monitor with LCD display. The units are also available for after market or retrofit installation. These units monitor line voltage inputs from 190 to 610 volts and provide protection against line voltage variances which can damage or destroy the compressor motor. Features include automatic system shutdown and restart based on current line conditions, a voltmeter, and a non-volatile system memory so settings are retained even if power is lost. If machine is ordered with this option the power monitor can be factory set to customer specifications. The Vogt Part number for a power monitor retrofit kit is [12A7700K01](#).



**FIGURE 10-1**  
**Power Monitor (Voltage Monitor)**

#### The Display

The display normally shows the AB BC CA line voltages.

If the unit is waiting on a timer, that timer will be displayed. The timer display may be switched off by pressing SELECT. The LCD will then display the normal AB BC CA line voltage pairs.

Pressing the SELECT button once shows the contactor load side voltages (if the load side option is connected). The display automatically returns to the display of line side voltage after a few seconds.

**Press the Select button to step through the parameters.** As you step through the parameters, the selected parameter will flash. Use the up and down arrow keys to adjust to the desired operating value.

**Parameter limits**

Parameter	Minimum	Maximum	Default	Recommended Settings	Unit
Line Side Voltage (Nominal Voltage)	90	650	<b>208</b>	<b>Supply voltage</b>	Volts
Over Voltage (tolerance)	6	18	<b>12</b>	<b>10</b>	%
Under Voltage (tolerance)	6	18	<b>12</b>	<b>10</b>	%
Phase Unbalance	2	25	<b>6</b>	<b>5</b>	%
Lockout Time (Delay on Break)	0.1	25	<b>0.5</b>	<b>120</b>	Seconds
Delay Time (Delay on Make)	0	30	<b>0</b>	<b>0</b>	Seconds
Response Time (Delay on Fault)	0.1	20	<b>2</b>	<b>2</b>	Seconds
Control Mode	Off / Auto / On		<b>Auto</b>	<b>On</b>	N/A
Contacteur Test	OFF	5	<b>OFF</b>	<b>OFF</b>	Volt Diff

**TABLE 10-1**  
**Power Monitor Parameters**

**Parameters adjustment (in order of display)**

Active display of Line Voltage (this is the default normal display)

Active display of Load Side Voltage (if connected)

Voltage Set Point

(VAC Flashes) The value may be adjusted by pressing the up and down arrows. This may be set to the normal operating voltage of the device being protected in one volt increments.

Under/over Voltage Tolerance in %

(UNDERVOLTAGE/OVERVOLTAGE flashes)

The value may be adjusted by pressing the up and down arrows.

Imbalance Voltage Tolerance in %

(% IMBALANCE flashes) The value may be adjusted by pressing the up and down arrows.

Lockout Time in seconds

(SECONDS flashes) The value may be adjusted by pressing the up and down arrows. (This is the delay on break timer value)

Delay time in seconds and tenths of seconds

(RESP. SECONDS flashes) The value may be adjusted by pressing the up and down arrows. This is the time that a fault is allowed before shutdown occurs.

Control mode

(ON OFF AUTO flashes) The value may be adjusted to OFF (load will not turn on), ON (load will turn on whenever there are not faults and timers are finished) and AUTO (Load will turn on when there is a control input).

Contacteur fault monitor mode

(CONTACTOR FAULT flashes) This option allows you to monitor the contactor and lock it out if the line voltage and load side varies by more than 5 volts. Pressing the up and down arrows selects off (default) or on. The load side of the contactor must be connected to the load terminals of the DTP-3 to use this option.

Display of fault memories

(MEM flashes) Pressing up or down displays the last fault conditions that took the unit off line. The first 25 faults are recorded. The top number displayed represents the fault memory. The middle number represents the total number of faults that have occurred since the fault memory was cleared.

To clear the memory, press and hold the up and down keys until the display is cleared.

**Notes**

If you press SELECT and do not change a parameter by pressing the up or down arrow keys, the DTP-3 automatically returns to displaying the line voltage in a few seconds.

The new settings are saved in permanent memory when the display returns to displaying the line voltage. The new settings may be verified by pressing the select button to sequence through the various parameters.

To prevent tripping on a 1 volt change, the DTP-3 automatically calculates cut-in voltages for the return from undervoltage conditions. The cut-out voltage is always based on user voltage and tolerance settings, while the cut-in voltage is 3% closer to the nominal voltage setting. This quality is sometimes referred to as hysteresis. This is to help reduce oscillation that may occur on weak power distribution system. When the load is switched off due to undervoltage, the line voltage will increase. Without the hysteresis, the monitor would switch the load back on, the line voltage would again drop, and cause a continuous on-off-on cycling.

### **PLC (Programmable Logic Controller)**

Tube-Ice<sup>®</sup> machines are available with a Mitsubishi FX<sub>1N</sub> 24MR programmable controller, FX<sub>2N</sub>-8ER expansion module and a Mitsubishi E1012 Operator interface. The E1012 interface contains a real-time clock and 6 programmable function keys that allow for easy screen navigation and enhanced machine operation over the standard Tube-Ice<sup>®</sup> machine mechanical controls.

*Note: The E1012 interface replaces the E150 and requires a 24VDC power supply to power the unit, where the E150 was power by the plc.*

The PLC/Interface add features such as selectable “Automatic Restart” after a power failure, choice of timed or pressure switch controlled freeze cycles and Freezer “pumpdown”. For package units, the machine will automatically “Pumpdown” before cycling off.

#### **The PLC/Interface provides programmable:**

- Cutter delay (amount of time at start of harvest before cutter comes on)
- Conveyor control contacts (delay at start of harvest before conveyor comes on and run time).
- Automatic Restart after a Power Failure (enable/disable)
- Auto-restart time (delay time before restarting – recommended 2 hours for package machines)

The PLC provides **Machine Fault** indication with an alarm relay. The PLC will log when the “fault” occurred (time and date) and were in the cycle the machine was when the fault occurred.

#### **Machine Faults:**

- Compressor high discharge pressure
- Compressor low suction pressure
- Compressor oil pressure
- Compressor motor fault
- Cutter motor overload
- Water pump motor overload
- Long cycle - a freeze cycle lasting more than 60 minutes
- Short cycle - 3 consecutive freeze cycles 5 minutes or less in duration
- Power failure / Power return

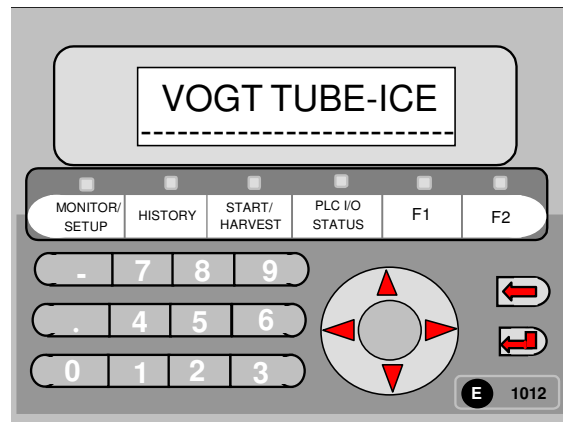
#### **Pumpdown Cycle**

Package Machines: When machine is turned “off” or the bin control tells the machine to cycle off, the machine will complete the harvest cycle then go to the Pumpdown Mode. During the Pumpdown cycle, the compressor and water pump will be “on”. When the FPS (freezer pressure switch) makes, the machine will go through a 60 sec Pumpdown harvest. (Note: Pumpdown harvest can be turned off using the Main Setup screen.) After completing this short harvest, the machine will continue to pump down until it shuts off on low pressure.

**Fault History** log (5 faults) will be created and can be viewed through the E150 Interface. The PLC also logs (time and date) when a “power failure” occurs and when power is returned.

**Cycle History** log (10 cycles) will also be created and viewed with the interface.

The **PLC I/O Status** screen can be used to view PLC Inputs and Outputs without opening the control panel door. A Total cycle counter and hour meter can also be view with the.



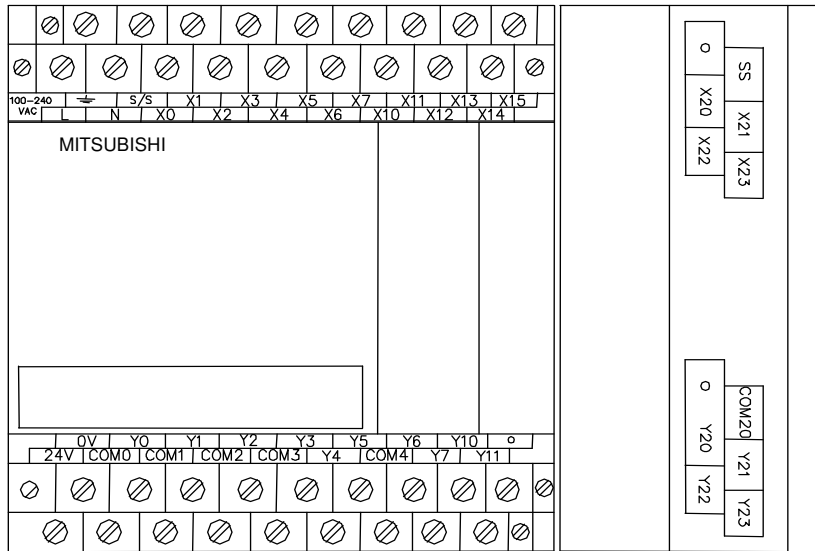
**Mitsubishi E1012 Operator Interface**

**FIGURE 10-2**  
**Mitsubishi HMI**

### MITSUBISHI PLC

The Mitsubishi Programmable controller contains 14 inputs and 10 outputs on the base unit with an additional 4 input and 4 outputs on an expansion module. The power supply for the unit can be 100-240VAC, 50/60 Hz and is internally fused for 3A. The inputs are 24VDC internally fused for 5-7mA and supplied by the PLC. All 24VDC control wiring is blue in color and is distinguished from the red 240VAC or 120VAC control wiring. The outputs are externally fused for 2A. Outputs 1 and 2 are dry contacts used for high side control interlock and conveyor control. Outputs 0, 3-11 & 20-23 are relay type with 120V or 200/240 V connections.

The LED indicators on the right hand side of the Mitsubishi PLC indicate the power, run and error status of the PLC. When power is on to the PLC and the run/stop switch is in the run position the power and run indicators will be illuminated. A solid or flashing error light indicates a processor or program error. The LED indicators on the upper right hand side of the PLC, indicates the input status and LED indicators on the lower right hand side of the PLC indicate the output status. If the input (X#) indicator is illuminated, then the PLC is receiving the input. If the output (Y#) indicator is illuminated, then the PLC is sending the output. Use of these LED's will be helpful in troubleshooting the machine.



**Mitsubishi FX<sub>1N</sub>-24MR PLC and FX<sub>2N</sub>-8ER-ES/UL**

**FIGURE 10-3**  
**Mitsubishi PLC**

<b>Inputs</b>	<b>Description</b>	<b>Outputs</b>	<b>Description</b>
0	Not used	0	Not used
1	Not used	1	High Side Control Interlock
2	Start / Manual Harvest Button	2	Conveyor Control Contact
3	Selector Switch (Clean position)	3	ET - Elapsed Timer
4	Selector Switch (Ice position) in series w/Bin control	4	Water Pump motor starter
5	Freezer Pressure switch	5	Alarm
6	Compressor overload for 4D & 6D without CoreSense	6	D-sol (defrost solenoid valve)
7	Cutter Motor overload	7	Not used
10	Pump Motor overload	10	Float switch / A-sol (liquid feed valve(s))
11	CoreSense (Oil press safety for comp without CoreSense)	11	Cutter motor starter
12	High / Low pressure safety		
13	Not used		
14	Not used		
15	Not used		
<b>Expansion Module</b>			
20	Not used	20	UN-sol (compressor unloader)
21	Not used	21	Not used
22	Not used	22	Not used
23	Not used	23	Not used

**TABLE 10-2**  
**PLC Input / Output Table**

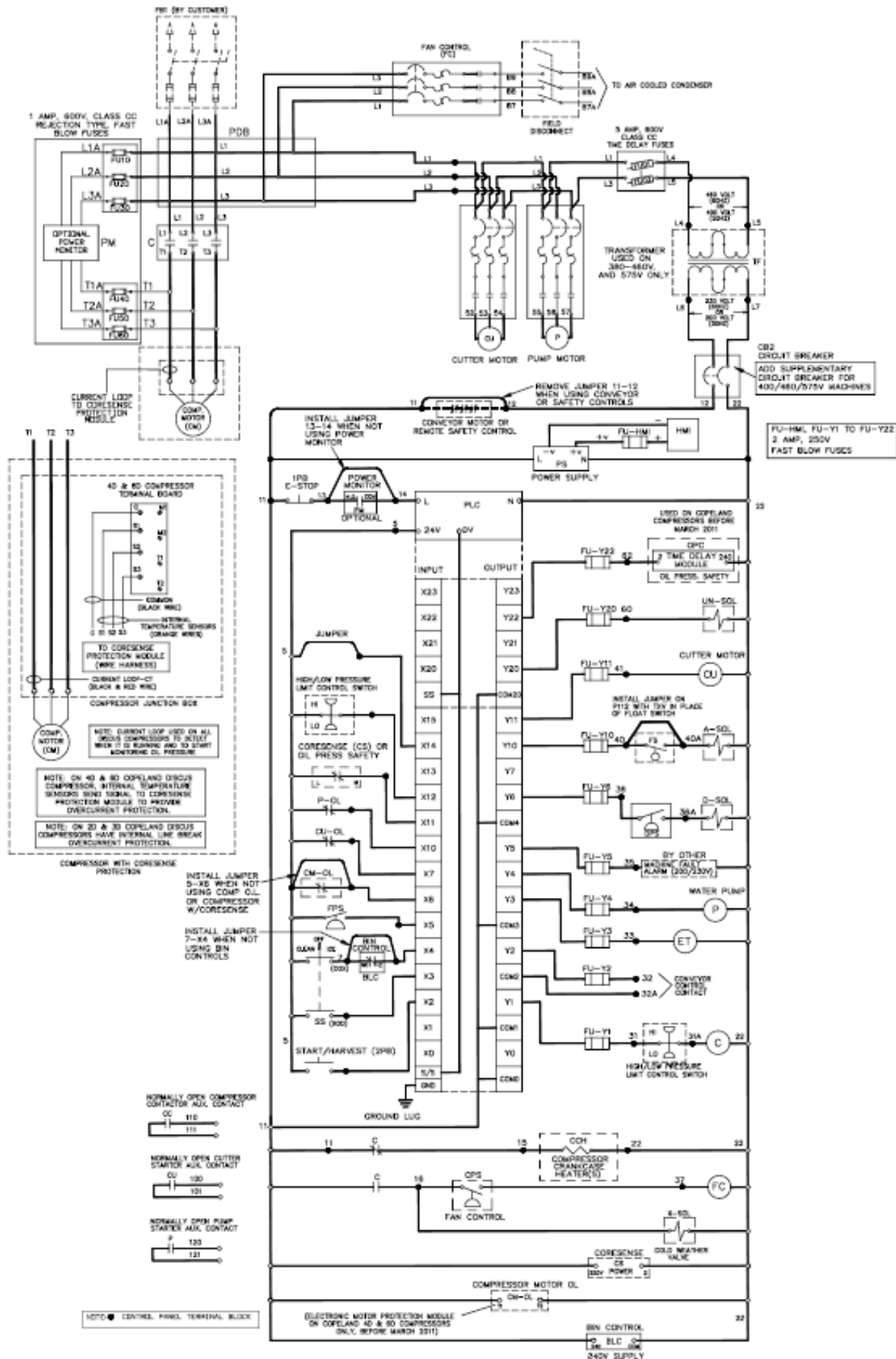


FIGURE 10-4  
Wiring Schematic – Mid Size Machine (P112, P118 & P18XT)

Blank page

## 11. Tables & Charts

03TA SPECIFICATIONS		208-230 Volt-3 Phase- 60Hz		200 Volt-3 Phase 50Hz	
Model Number		HE60S/P112-1	HE60M/P112-1 1/4	HE60S/P112-1	HE60M/P112-1 1/4
Tube Size	inches (cm)	1 (2.54)	1 1/4 (3.17)	1 (2.54)	1 1/4 (3.17)
Nominal Capacity <sup>(1)</sup>	lbs/day (Kg/day)	6,024 (2,732)	5,725 (2,597)	5,904 (2,678)	5,611 (2,545)
Overall Dimensions (LxWxH)	inches (meters)	50 x 29 x 72 (1.3x0.74x1.8)	50 x 29 x 72 (1.3x0.74x1.8)	50 x 29 x 72 (1.3x0.74x1.8)	50 x 29 x 72 (1.3x0.74x1.8)
Shipping Weight	lbs (Kg)	1800 (816)	1800 (816)	1800 (816)	1800 (816)
Operating Weight	lbs (Kg)	1830 (830)	1830 (830)	1830 (830)	1830 (830)
Refrigerant Charge (HFC-404a)	lbs (Kg)	130 (59)	130 (59)	130 (59)	130 (59)
Total FLA Water Cooled <sup>(2)</sup>		48.4	48.4	51.5	51.5
Total FLA Air Cooled <sup>(2)</sup>		62.4	62.4	65.6	65.6
Maximum Fuse	WC / AC	100/115	100/115	110/120	110/120
Minimum Ampacity	WC / AC	60/60	60/60	55/60	55/60
<b>Water Requirements</b>					
-makeup <sup>(3)</sup>	gpm (L/m)	0.6 (2.3)	0.6 (2.3)	0.6 (2.3)	0.6 (2.3)
-condenser <sup>(4)</sup>	gpm (L/m)	30 (114)	30 (114)	30 (114)	30 (114)
<b>Connection Sizes</b>					
-makeup water	FPT	3/8"	3/8"	3/8"	3/8"
-tank drain	FPT	3/4"	3/4"	3/4"	3/4"
-condenser water inlet	FPT	1 1/4"	1 1/4"	1 1/4"	1 1/4"
-condenser water outlet	MPT	1 1/4"	1 1/4"	1 1/4"	1 1/4"
-AC condenser inlet	ODC	1 3/8"	1 3/8"	1 3/8"	1 3/8"
-AC condenser outlet	ODC	1 1/8"	1 1/8"	1 1/8"	1 1/8"
Compressor -HP/KW/FLA		7.5 / 5.6 / 41.0	7.5 / 5.6 / 41.0	10 / 7.5 / 43.6	10 / 7.5 / 43.6
Water Pump -HP/KW/FLA		1.5 / 1.9 / 4.8	1.5 / 1.9 / 4.8	1.5 / 1.9 / 4.8	1.5 / 1.9 / 4.8
Cutter Motor -HP/KW/FLA		0.5 / .37 / 2.2	0.5 / .37 / 2.2	0.5 / .37 / 2.2	0.5 / .37 / 2.2
THR	Btu/hr (kW)	122,000 (35.7)	122,000 (35.7)	122,000 (35.7)	122,000 (35.7)
<b>Marley Cooling Tower<sup>(5)</sup></b>					
-dim. (LxWxH)	ft (meters)	4 x 5 x 6.5 (1.2x1.5x2.0)	4 x 5 x 6.5 (1.2x1.5x2.0)	4 x 5 x 6.5 (1.2x1.5x2.0)	4 x 5 x 6.5 (1.2x1.5x2.0)
-shipping weight	lbs (Kg)	650 (336)	650 (336)	650 (336)	650 (336)
-operating weight	lbs (Kg)	999 (608)	999 (608)	999 (608)	999 (608)
-connections (inlet x outlet)	NPT	4" x 4"	4" x 4"	4" x 4"	4" x 4"
-fan (HP/KW/FLA)		1 / 0.8 / 3.6	1 / 0.8 / 3.6	1 / 0.8 / 3.6	1 / 0.8 / 3.6
<b>Tower Pump</b>					
-flow	gpm (m <sup>3</sup> /Hr)	30 (6.81)	30 (6.81)	30 (6.81)	30 (6.81)
-TDH minimum	ft (m)	80 (24.4)	80 (24.4)	80 (24.4)	80 (24.4)
-connections (inlet x outlet)	FPT	1" x 1.25"	1" x 1.25"	1" x 1.25"	1" x 1.25"
-HP/KW/FLA		1 / 0.8 / 3.6	1 / 0.8 / 3.6	1 / 0.8 / 3.6	1 / 0.8 / 3.6
-shipping weight	lbs (Kg)	65 (29.5)	65 (29.5)	65 (29.5)	65 (29.5)
<b>Bohn Air-Cooled Condenser<sup>(6)</sup></b>					
- # of Fans / HP		2 / 1.5	2 / 1.5	2 / 1.5	2 / 1.5
-total KW/FLA (230V)		2.2 / 14	2.2 / 14	2.2 / 14	2.2 / 14
-inlet connection	ODC	1 3/8"	1 3/8"	1 3/8"	1 3/8"
-outlet connection	ODC	1 1/8"	1 1/8"	1 1/8"	1 1/8"
-shipping weight	lbs (Kg)	760 (345)	760 (345)	765 (347)	765 (347)
-operating weight	lbs (Kg)	580 (263)	580 (263)	585 (265)	585 (265)

(1) Nominal capacity is based on 70°F make-up water, 100°F condensing temp, and 90°F amb temp

(2) FLA for 460/ 380 V models is approximately 1/2 that of 230/ 200 V models. Total FLA does not include cooling tower.

(3) Makeup water is maximum value and includes 10 gallons per cycle blowdown. .

(4) Condenser flow rate is for 85°F entering water temp and 100°F condensing.

(5) Tower sized for 80°F wet bulb temperature

(6) Recommended air-cooled condenser is based on 15°F TD.

Vogt reserves the right to change designs and specifications without notice.

### Table 11-1

TABLES & CHARTS

**03TA Capacity Ratings**

Makeup Water Temp. Deg. F.	Rated Capacity (lbs/day)							
	60Hz				50Hz			
	Cylinder		Crushed		Cylinder		Crushed	
	1"	1 1/4"	1"	1 1/4"	1"	1 1/4"	1"	1 1/4"
40	6955	6592	7233	6856	6816	6460	7088	6719
41	6925	6564	7202	6826	6786	6432	7058	6690
42	6895	6535	7171	6796	6757	6404	7027	6660
43	6865	6506	7139	6767	6727	6376	6997	6631
44	6835	6478	7108	6737	6698	6348	6966	6602
45	6805	6449	7077	6707	6668	6320	6935	6573
46	6775	6421	7045	6677	6639	6292	6905	6544
47	6744	6392	7014	6648	6610	6264	6874	6515
48	6714	6364	6983	6618	6580	6236	6843	6486
49	6684	6335	6952	6588	6551	6208	6813	6457
50	6686	6347	6953	6601	6552	6220	6814	6469
51	6652	6312	6918	6564	6519	6186	6780	6433
52	6619	6277	6884	6528	6487	6151	6746	6398
53	6585	6243	6848	6493	6453	6118	6711	6363
54	6552	6208	6814	6456	6421	6084	6678	6327
55	6518	6173	6779	6420	6388	6050	6643	6292
56	6484	6139	6743	6385	6354	6016	6608	6257
57	6451	6104	6709	6348	6322	5982	6575	6221
58	6417	6070	6674	6313	6289	5949	6540	6187
59	6384	6035	6639	6276	6256	5914	6507	6151
60	6350	6000	6604	6240	6223	5880	6472	6115
61	6318	5973	6571	6212	6192	5854	6439	6088
62	6285	5945	6536	6183	6159	5826	6406	6059
63	6252	5918	6502	6155	6127	5800	6372	6032
64	6220	5890	6469	6126	6096	5772	6339	6003
65	6187	5863	6434	6098	6063	5746	6306	5976
66	6155	5835	6401	6068	6032	5718	6273	5947
67	6122	5808	6367	6040	6000	5692	6240	5920
68	6089	5780	6333	6011	5967	5664	6206	5891
69	6057	5753	6299	5983	5936	5638	6173	5863
70	6024	5725	6265	5954	5904	5611	6140	5835
71	5997	5697	6237	5925	5877	5583	6112	5806
72	5969	5669	6208	5896	5850	5556	6084	5778
73	5942	5641	6180	5867	5823	5528	6056	5749
74	5914	5613	6151	5838	5796	5501	6028	5721
75	5887	5585	6122	5808	5769	5473	6000	5692
76	5860	5557	6094	5779	5743	5446	5973	5664
77	5832	5528	6065	5749	5715	5417	5944	5634
78	5805	5500	6037	5720	5689	5390	5916	5606
79	5777	5472	6008	5691	5661	5363	5888	5577
80	5750	5444	5980	5662	5635	5335	5860	5549
81	5723	5418	5952	5635	5609	5310	5833	5522
82	5696	5393	5924	5609	5582	5285	5805	5497
83	5669	5367	5896	5582	5556	5260	5778	5470
84	5643	5341	5869	5555	5530	5234	5751	5444
85	5616	5316	5841	5529	5504	5210	5724	5418
86	5589	5290	5813	5502	5477	5184	5696	5392
87	5562	5265	5784	5476	5451	5160	5669	5366
88	5535	5239	5756	5449	5424	5134	5641	5340
89	5509	5213	5729	5422	5399	5109	5615	5313
90	5482	5188	5701	5396	5372	5084	5587	5288

Capacity rating based on 70°F ambient conditions, 100°F SDT temperature.

Capacity rating is average for the model. Individual machines may vary up to 5% above or below.

Capacity rating is for clear ice production with makeup water containing no more than 200ppm total dissolved solids.

**Table 11-2**

Condensing Temp. °F	Entering Water Temp. °F	Leaving Water Temp. °F	Water Flow GPM	Pressure Drop	Average Total Heat of Rejection
100	50	92	4	1	122,000
100	55	92	5	1	122,000
100	60	92	7	1	122,000
100	65	92	8	1	122,000
100	70	93	10	1	122,000
100	75	93	13	2	122,000
100	80	94	18	2	122,000
100	85	94	29	6	122,000
105	90	95	46	11	122,000
110	95	100	50	11	122,000

**Condenser Water Usage  
Table 11-3**

Make-up Water Temp. °F	Cylinder Ice		Crushed Ice	
	Tube Size		Tube Size	
	1"	1 1/4"	1"	1 1/4"
40	0.69	0.66	0.71	0.69
50	0.66	0.63	0.68	0.65
60	0.62	0.59	0.65	0.61
70	0.60	0.56	0.62	0.59
80	0.56	0.53	0.59	0.55
90	0.54	0.50	0.56	0.53

Includes 15% Blowdown

**Make-up Water Usage (gpm)  
Table 11-4**

			Suction Pressure (psig)		Discharge Pressure (psig)		Harvest Times (sec)			Ice per cycle Avg (lbs)	Freeze Time (minutes)				
			End of Freeze		Average during Freeze		First Ice	All Ice Out	Total Harvest		Water Temperature (°F)				
			R22	R404A	R22	R404A					90	80	70	60	50
60 HZ	CYL	1"	33	45	200	240	15	90	120	63	15.5	14.5	13.4	12.4	11.4
		1 1/4"	32	44	200	240	15	90	120	60	17.9	16.5	15.3	14.3	12.9
	CRU	1"	35	47	200	240	15	90	120	49	14.1	13.3	12.5	11.8	11.1
		1 1/4"	34	46	200	240	15	90	120	47	15.8	14.8	14.0	13.2	12.2
50 HZ	CYL	1"	33	45	200	240	15	90	120	62	15.5	14.5	13.4	12.4	11.4
		1 1/4"	32	44	200	240	15	90	120	59	17.9	16.5	15.3	14.3	12.9
	CRU	1"	35	47	200	240	15	90	120	48	14.1	13.3	12.5	11.8	11.1
		1 1/4"	34	46	200	240	15	90	120	46	15.8	14.8	14.0	13.2	12.2

**Normal Operating Vitals  
Table 11-5**

## TABLES &amp; CHARTS

**RECOMMENDED SPARE PARTS LIST****Vogt Model 03TA Tube-Ice<sup>®</sup> Machine**


---

<b><u>QTY</u></b>	<b><u>PART NUMBER</u></b>	<b><u>DESCRIPTION</u></b>
1	<a href="#">12A2117E04</a>	Freezer pressure switch
1	<a href="#">12A7503E22</a>	Thawing timer
1	12A7517E27	CR Relay, 208/230v, 50/60hz.
2	<a href="#">12A7516E23</a>	Cutter, Pump and PF Contactor, 9A, 208/230v, 50/60hz
1	See Page 6-3	CU/P Starter
1	See Page 6-3	Compressor Contactor
1	<a href="#">12A2900M0508</a>	Cutter motor, 1/2 HP
2	<a href="#">12A4200H0401</a>	Make-up water float valve
1	<a href="#">12B2020R04</a>	Cutter bearing
78	<a href="#">12B2185N11</a>	Water Distributors (1")
48	<a href="#">12B2185N21</a>	Water Distributors (1 1/4")
1	<a href="#">12A2600G01</a>	Gasket for freezer cover
1	<a href="#">12A2600G12</a>	Gasket for water tank
1	<a href="#">12A7509E12</a>	Crankcase heater, (Copeland Discus Compressor)
1	<a href="#">12A4200A0505</a>	5/8" Liquid feed solenoid, Sporlan
1	<a href="#">12A4200C0503</a>	Thermal Expansion Valve, R404A

**TO ORDER SPARE PARTS, PLEASE CONTACT YOUR DISTRIBUTOR.**

**TEMPERATURE - PRESSURE CHART  
FOR COMMON REFRIGERANTS**

DegF	R-12	R-22	R-502	R-134a	MP-39	R-404a	HP-80
-50	-7.6	-3.0	0.2	-9.0	-9.1	0.0	1.2
-48	-7.2	-2.4	0.7	-8.7	-8.7	0.8	2.1
-46	-6.8	-1.7	1.5	-8.3	-8.3	1.6	2.9
-44	-6.3	-1.0	2.3	-8.0	-7.9	2.5	3.9
-42	-5.8	-0.2	3.2	-7.6	-7.4	3.4	4.9
-40	-5.4	0.5	4.1	-7.1	-7.1	5.5	5.9
-38	-4.9	1.3	5.0	-6.7	-6.6	6.5	6.9
-36	-4.4	2.2	6.0	-6.3	-6.1	7.5	8.0
-34	-3.8	3.0	7.0	-5.8	-5.6	8.6	9.2
-32	-3.3	4.0	8.1	-5.3	-5.2	9.7	10.3
-30	-2.7	4.9	9.2	-4.8	-4.4	10.8	11.6
-28	-2.1	5.9	10.3	-4.2	-4.1	12.0	12.8
-26	-1.5	6.9	11.5	-3.8	-3.4	13.2	14.1
-24	-0.8	7.9	12.7	-3.0	-2.9	14.5	15.5
-22	-0.1	9.0	14.0	-2.4	-2.2	15.8	16.9
-20	0.6	10.1	15.3	-1.8	-1.7	17.1	18.4
-18	1.3	11.3	16.7	-1.1	-1.0	18.5	19.9
-16	2.1	12.5	18.1	-0.4	-0.2	20.0	21.5
-14	2.8	13.8	19.5	0.3	0.4	21.5	23.1
-12	3.7	15.1	21.0	1.1	1.4	23.0	24.8
-10	4.5	16.5	22.6	1.9	2.2	24.6	26.5
-8	5.4	17.9	24.2	2.8	3.1	26.3	28.3
-6	6.3	19.3	25.8	3.6	3.9	28.0	30.2
-4	7.2	20.8	27.5	4.5	4.8	29.8	32.1
-2	8.2	22.4	29.3	5.5	5.7	31.6	34.1
0	9.2	24.0	31.1	6.5	6.7	33.5	36.1
2	10.2	25.6	32.9	7.5	7.7	35.6	38.1
4	11.2	27.3	34.9	8.5	8.8	37.4	40.4
6	12.3	29.1	36.9	9.6	9.9	39.4	42.6
8	13.5	30.9	38.9	10.8	11.0	41.6	44.9
10	14.6	32.8	41.0	12.0	12.2	43.9	47.3
12	15.8	34.7	43.2	13.1	13.4	46.0	49.7
14	17.1	36.7	45.4	14.4	14.6	48.3	52.2
16	18.4	38.7	47.7	15.7	15.9	50.7	54.8
18	19.7	40.9	50.0	17.0	17.2	53.1	57.5
20	21.0	43.0	52.5	18.4	18.6	55.6	60.2
22	22.4	45.3	54.9	19.9	20.0	58.2	63.0
24	23.9	47.6	57.5	21.4	21.5	59.9	65.9
26	25.4	49.9	60.1	22.9	23.0	63.6	68.9
28	26.9	52.4	62.8	24.5	24.6	66.5	72.0
30	28.5	54.9	65.6	26.1	26.2	69.4	75.1
32	30.1	57.5	68.4	27.8	27.9	72.3	78.3
34	31.7	60.1	71.3	29.5	29.6	75.4	81.6
36	33.4	62.8	74.3	31.3	31.3	78.5	85.0
38	35.2	65.6	77.4	33.2	33.2	81.8	88.5
40	36.9	68.5	80.5	35.1	35.0	85.1	92.1
42	38.8	71.5	83.8	37.0	37.0	88.5	95.7
44	40.7	74.5	87.0	39.1	39.0	91.9	99.5
46	42.7	77.6	90.4	42.0	41.0	95.5	103.4
48	44.7	80.7	93.9	43.3	43.1	99.2	107.3
50	46.7	84.0	97.4	45.5	45.3	102.9	111.4

DegF	R-12	R-22	R-502	R-134a	MP-39	R-404a	HP-80
50	46.7	84.0	97.4	45.5	45.3	102.9	111.4
52	48.8	87.3	101.0	47.7	60.0	109.0	120.0
54	51.0	90.8	104.8	50.1	62.0	113.0	124.0
56	53.2	94.3	108.6	52.3	65.0	117.0	129.0
58	55.4	97.9	112.4	55.0	68.0	121.0	133.0
60	57.7	101.6	116.4	57.5	70.0	125.0	138.0
62	60.1	105.4	120.4	60.1	73.0	130.0	142.0
64	62.5	109.3	124.6	62.7	76.0	134.0	147.0
66	65.0	113.2	128.8	65.5	79.0	139.0	152.0
68	67.6	117.3	133.2	68.3	82.0	144.0	157.0
70	70.2	121.4	137.6	71.2	85.0	148.0	162.0
72	72.9	125.7	142.2	74.2	89.0	153.0	168.0
74	75.6	130.0	146.8	77.2	92.0	158.0	173.0
76	78.4	134.5	151.5	80.3	95.0	164.0	179.0
78	81.3	139.0	156.3	83.5	99.0	169.0	184.0
80	84.2	143.6	161.2	86.8	102.0	174.0	190.0
82	87.2	148.4	166.2	90.2	106.0	180.0	196.0
84	90.2	153.2	171.4	93.6	109.0	185.0	202.0
86	93.3	158.2	176.6	97.1	113.0	191.0	208.0
88	96.5	163.2	181.9	100.7	117.0	197.0	214.0
90	99.8	168.4	187.4	104.4	121.0	203.0	220.0
92	103.1	173.7	192.9	108.2	125.0	209.9	227.0
94	106.5	179.1	198.6	112.1	129.0	215.0	234.0
96	110.0	184.6	204.3	116.1	133.0	222.0	240.0
98	113.5	190.2	210.2	120.1	138.0	229.0	247.0
100	117.2	195.9	216.2	124.3	142.0	235.0	254.0
102	120.9	201.8	222.3	128.5	146.0	242.0	261.0
104	124.7	207.7	228.5	132.9	151.0	249.0	269.0
106	128.5	213.8	234.9	137.3	156.0	256.0	276.0
108	132.4	220.0	241.3	142.8	160.0	264.0	284.0
110	136.4	226.4	247.9	146.5	165.0	271.0	292.0
112	140.5	232.8	254.6	151.3	170.0	279.0	299.0
114	144.7	239.4	261.5	156.1	175.0	286.0	307.0
116	148.9	246.1	268.4	161.1	180.0	294.0	316.0
118	153.2	252.9	275.5	166.1	185.0	302.0	324.0
120	157.7	259.9	282.7	171.3	191.0	311.0	332.0
122	162.2	267.0	290.1	176.6	196.0	319.0	341.0
124	166.7	274.3	297.6	182.0	202.0	328.0	350.0
126	171.4	281.6	305.2	187.5	207.0	336.0	359.0
128	176.2	289.1	312.9	193.1	213.0	345.0	368.0
130	181.0	296.8	320.8	198.9	219.0	354.0	377.0
132	185.9	304.6	328.9	204.7	225.0	364.0	387.0
134	191.0	312.5	337.1	210.7	231.0	373.0	396.0
136	196.2	320.6	345.4	216.8	237.0	383.0	406.0
138	201.3	328.9	353.9	223.0	243.0	392.0	416.0
140	206.6	337.3	362.6	229.4	250.0	402.0	426.0
142	212.0	345.8	371.4	235.8	256.0	412.0	436.0
144	217.5	354.5	380.4	242.4	263.0	423.0	447.0
146	223.1	363.4	389.5	249.2	269.0	434.0	458.0
148	228.8	372.3	398.9	256.0	277.0	444.0	468.0
150	234.6	381.5	408.4	263.0	283.0	449.0	479.0

**TABLE 11-6**  
All pressures are in lbs/in<sup>2</sup> gage (psig).

## TABLES &amp; CHARTS

**REFERENCE INFORMATION****CONVERSION FACTORS: English to Metric**

To Convert	From	To	Multiply by
Area	ft <sup>2</sup>	m <sup>2</sup>	9.2903e-2
	in <sup>2</sup>	m <sup>2</sup>	6.416 e-4
Energy	BTU	Joule (J)	1054.48
	Hp	BTU/Hr	2546.2
	KW	Hp	1.34
Length	ft.	m.	0.3048
	in.	m.	0.0254
Pressure	Lbf/ft <sup>2</sup>	Pa	47.88
	Lbf/in <sup>2</sup> (psi)	Pa	6894.76
	In. Hg	psi	0.491
	In H <sub>2</sub> O	psi	0.03612
Temperature	°F	°C	$T_C = 5/9 * (T_F - 32)$
	°C	°F	$T_F = (9/5 * T_C) + 32$
Volume	Ft <sup>3</sup>	m <sup>3</sup>	2.8317e-2
	Gal(U.S.)	m <sup>3</sup>	3.7854e-3
	Ft <sup>3</sup>	Gal(U.S.)	7.48

**TABLE 11-7****CONSTANTS**

Specific heat of Water	1 BTU/(lbm °F)
Specific heat of Air	4.19 kJ/(kg °C) 0.24 BTU/(lbm °F)
Tube-Ice Density	32-35 lbs/ft <sup>3</sup>
Ice Latent Heat	144 BTU/hr
Water Sensible Heat	1 BTU/(lb °F)
Ice Melting Effect (IME) 1 Ton Refrigeration	12,000 BTU/hr
Atmospheric pressure	14.7 psia
Weight of Water	62.4 lbs/ft <sup>3</sup> 8.33 lbs/gal
1 gpm water	12013 lb/day
Weight of air	0.0749 lbs/ft <sup>3</sup> 0.0100 lbs/gal
1 Horsepower	2545.6 BTU/hr
1 Kilowatt	1.34 horsepower
Gravitational acceleration	9.81 m <sup>2</sup> /sec

**TABLE 11-8**

## 12. Index

<b>A</b>	
A Valve (Liquid Feed Solenoid Valve) -----	4-1, 5-1, 9-6
Accumulator -----	4-1, 5-1
Adding Refrigerant -----	5-4
Air - cooled Condenser Wiring (3 phase) -----	3-16
Air-Cooled Condenser -----	9-13
Air-Cooled Condenser Data -----	3-12
Air-Cooled Condenser Installation -----	3-10
Air-Cooled Piping Schematic -----	4-4
Air-Cooled Units -----	9-5
Allen-Bradley Switch -----	9-3
Assembly Drawing, Air-Cooled -----	1-4, 1-5, 1-6
Assembly Drawing, Water Cooled -----	1-7, 1-8, 1-9
Automatic blowdown -----	9-1
<b>B</b>	
Basic Product Warranty -----	inside back cover
Bearing, Cutter -----	9-19, 9-20
Bill of Lading -----	2-1
Bin, Electronic Thermostat Programming -----	3-19
Bin, Electronic Thermostat Installation -----	3-18
Blowdown -----	9-1
Burnout, Compressor -----	9-15
<b>C</b>	
Capacity Ratings -----	11-2
Centrifugal Pump -----	9-11
Charging Refrigeration Systems -----	1-2
Check Valve -----	4-2
Checklist, Daily -----	7-9
Checklist, Start-up -----	5-2
Chemical Cleaning -----	7-5
Circuit Breaker, Control -----	6-5
Circulating Water Pump Motor -----	9-11
Clean/Ice Switch -----	6-4
Cleaning Procedure -----	7-1
Compressor -----	7-6
Compressor Crankcase Heater -----	9-7
Compressor Lubrication -----	7-6
Compressor Motor Burnout -----	9-15
Compressor Unloader -----	9-16
Compressor, Contactor -----	6-5
Condenser Cleaning -----	7-5, 9-13
Condenser Fan Contactor (FC) -----	6-5, 6-6
Condenser Fan Switch -----	9-5
Condenser Piping (Cold Weather Valve Kit) -----	3-14
Condenser Water Usage -----	11-3
Condenser, Air-cooled Cleaning -----	9-13
Condenser, Air-cooled Heat Rejection -----	3-12
Condenser, Pressure Switch (CPS) -----	9-5
Condenser, Water Cooled Maintenance -----	7-5
Control Circuit Protection -----	9-10
Control Panel -----	6-1
Control Panel Parts -----	6-5
Control, Relay (CR) -----	6-5
Cooling Tower -----	3-7
Crankcase Heater -----	7-6, 9-7
Crushed Ice Production -----	9-21
Cutter & Bearing Removal/Installation -----	9-18
Cutter, Assembly -----	9-19
Cutter, Bearing -----	9-18, 9-19
Cutter, Bearing Support -----	9-18, 9-19
Cutter, Disc Assembly -----	9-18, 9-19
Cutter, Drive Parts -----	9-18, 9-19
Cutter, Gear Reducer -----	7-7, 9-10, 9-18, 9-19
Cutter, Motor -----	9-18, 9-19
Cutter Assembly -----	9-20
Cutter Parts (crushed Ice) -----	9-20
Cutter/Water Tank Parts (cylinder ice) -----	9-18
<b>D</b>	
D Valve (Thawing Gas) -----	4-1, 9-6
Daily Check List -----	7-9
Drive gear -----	9-19
<b>E</b>	
Electrical Connection -----	3-8
Electrical Schematic All Voltages 50-60 Hz. -----	6-7
Electrical, Controls -----	6-5
Enclosure -----	6-1
Energy Saving -----	1-1
Equivalent Feet Due To Friction -----	3-15
<b>F</b>	
Fan Contactor (FC) -----	6-5
Filter/Drier -----	4-1
Float Valve (Make-Up Water) -----	9-1
Freeze Period -----	4-2
Freeze-Up Due To Extended Freezing Period -----	8-4
Freeze-Up Due To Ice Failing To Discharge -----	8-5
Freezer -----	4-1
Freezer Pressure Switch -----	9-3
<b>G</b>	
Gear Reducer -----	9-11
<b>H</b>	
Harvest Period -----	4-2
Head Pressure -----	9-4
Heat Exchanger -----	4-1
Heater, Crankcase -----	9-7
High Head Pressure (Air-Cooled) -----	8-10
High Head Pressure (Water Cooled) -----	8-9
High/Low Pressure Switch -----	9-4

## INDEX

History, Tube-Ice®	1-1	Preventive Maintenance Program	7-10
Hub, Cutter Drive Gear	9-19	Preview	1-1
<b>I</b>			
Ice Bin Thermostat Location	3-18	Principle of Operation	4-1
Ice Capacity	11-2	Pump Down	9-13
Ice-Making Section	7-1	Pump, Motor Starter	6-5
Important Safety Notice	1-2	<b>Q</b>	
Inspection, First Arrival	2-1	<b>R</b>	
Installation	3-1	R-22 (HCFC-22)	1-2, 2-2, 5-1
Introduction	1-1	R-404a (HFC "SUVA" HP62)	1-2, 2-2, 5-1
<b>J, K</b>			
<b>L</b>			
Low Compressor Oil Level	8-7	Receipt of Machine	2-1
Low Ice Capacity	8-6	Receiver	4-1
Low Pressure Switch	9-5	Refrigerant, Charge	5-1
Lubrication	7-6	Refrigerant, Leaks	9-14
Lubrication, Compressor	7-6	Refrigerant, Removal	9-14
Lubrication, Cutter Gear Reducer	7-7	Refrigeration System Review	5-1
<b>M</b>			
Machine Ratings (50 Hz., 10 HP)	11-1	Rotation Check	3-9
Machine Ratings (60 Hz., 7.5 HP)	11-1	<b>S</b>	
Machine Room	2-1	Safety Notice	1-2
Machine Weight	2-1	Safety Symbols and What They Mean	1-3
Machine Won't Run	8-2, 8-3	Safety Valves	2-1
Maintenance	7-1	Sanitizing Procedure	7-2
Maintenance Program	7-10	Shipping Papers	2-1
Make-Up Water Connection Size	3-6	Solenoid Valve	9-6
Manual Harvest Push Button (PB2)	5-3, 5-5, 6-1, 6-5	Space Diagram (Air-Cooled Machine)	3-4
Metric Conversion	11-6	Space Diagram (Water Cooled Machine)	3-5
Mechanical Cleaning	7-5	Special Precautions	1-2
<b>N</b>			
NEMA	2-1	Start Push Button (PB1)	5-3, 5-5, 6-6
Nomenclature, Piping Schematic	4-2	Start-Up	5-3
Non-Condensable Gases	9-14	Start-Up Checklist	5-2
Normal Operating Vitals	11-5	Storage (prior to installation and start-up)	2-2
<b>O</b>			
Oil Pressure Safety Control	9-8	Suction Cut-Off Unloader	9-16
On/Off Switch	5-3, 5-5, 6-1, 6-5	Symptoms, Troubleshooting	8-1
Operating Tips	5-5	<b>T</b>	
Operation Vitals	11-3	Telephone Number, Vogt	1-1
Optional Equipment, Power Monitor	10-1	Temperature-Pressure Chart	11-5
<b>P</b>			
Pin, Stainless Steel	9-19, 9-20	Thawing, Chamber	4-1
Piping and Drain Connections	3-6	Thermostat, Bin Installation	3-18
Piping Schematic, Nomenclature	4-2	Thermostat, Programming	3-19
Piping Schematic, Water-cooled	4-3	Timer, Thawing	6-5, 9-12
Piping Schematic, Air-Cooled	4-4	Trap (AC Piping)	3-10, 3-15
Poor Ice Quality	8-8	Troubleshooting	8-1
Power Connection	3-8	Troubleshooting, Power Monitor	10-4
Power Monitor	10-1	<b>U</b>	
Preventive Maintenance	7-1	Unloader - Loaded Operation (Freeze Period)	9-16
<b>V</b>			
<b>W</b>			
Warranty (Basic Product)			inside back cover
Water Treatment			3-7

Water Cooled Condenser -----3-7, 7-3  
Water Cooled Condenser Cleaning -----7-5  
Water Cooled Machine, Installation -----3-5  
Water Cooled Piping Schematic -----4-3  
Water Cooled Units -----9-4  
Water Distributors -----7-3  
Water Pump Motor -----9-10  
Water Regulating Valve -----9-5  
Water Supply and Drain, Water Cooled-----3-6  
Water Supply and Drains, Air-cooled -----3-6  
Water Tank-----7-3  
Water Tank Removal-----9-18  
Water Usage, Condenser -----11-3  
Water Usage, Make-up -----11-3  
Wiring and Electrical Connection -----3-6  
Wiring Schematic, Air Cooled Condenser -----3-16  
Wiring Schematic, All Voltages - 50/60 Hz-----6-7

**X**

X Valve -----4-2

**Y, Z**

INDEX