

***VT-Series  
Ice Maker***

**Model  
VT40, VT60, VT100**



## **FOREWORD**

*Vogt Ice®*, LLC, strives to provide a quality product that is time-tested and will provide years of dependable service to its customers.

*Skilled craftsmen have carefully assembled your Vogt® VT Series ice maker using material components and parts available from the leading vendors and producers of the highest quality refrigeration equipment in our industry. You have invested in quality equipment, and we pledge to support your needs and requirements after the sale.*

*This manual is provided to aid the service technician and users in the installation, operation, and maintenance of your equipment. Before attempting to install and start the machine, the installer should read and understand each section of this manual.*

*If, at any time, you encounter conditions that we have not addressed in this manual, we welcome you to write or call Vogt® Ice, LLC and we will give your questions our immediate attention and reply.*

**Vogt Ice®**, LLC  
1000 W. Ormsby Avenue  
Suite 19  
Louisville, KY 40210  
(502) 635-3000  
(502) 634-3024 Fax



# TABLE OF CONTENTS

## ***General Information - Section 1***

History of Company .....	1-1
Receipt of Your Ice Machine.....	1-2

## ***Installation Information - Section 2***

Important Safety Notice .....	2-1
Machine Dimension .....	2-2
Machine Weights & Refrigerant Line Sizes.....	2-2
Ice Chute Cutout .....	2-3
Water Connections .....	2-4
Water Flow Rates / Water Tank Capacity .....	2-4
Electrical Connections .....	2-5
Air Cooled Condenser Electrical Connections .....	2-6
Lowside Electrical Connections .....	2-6
Air Cooled Condenser Installation .....	2-7
Air Cooled Condenser Wiring (Kramer) .....	2-9
Air Cooled Condenser Wiring (KeepRite) .....	2-10
Air Cooled Condenser Connections.....	2-12
Storing Ice – Bin Thermostat Mounting .....	2-14

## ***Model Specifications and Wiring Diagrams - Section 3***

Model Specifications.....	3-1
Model Number Structure .....	3-2

## ***Initial Startup - Section 4***

Startup Procedure .....	4-1
Circuit Breakers & Lowside Control Panel Front.....	4-2
Service Valve Locations .....	4-3
Adding Refrigerant.....	4-4
Suction Line Access Port.....	4-4
Removing Refrigerant.....	4-5

## ***Electrical Controls - Section 5***

Explanation of Controls.....	5-1
Startup & Standby Mode .....	5-1
Freeze Mode .....	5-1
PLC & Freezer Timer .....	5-1
Harvest Mode .....	5-2
Harvest Hold Pressure Switch (Increasing Harvest) .....	5-2
Pumpdown Mode.....	5-2
Clean Mode .....	5-3
Fault Mode & Faults Designations .....	5-3
PLC Input / Output Table .....	5-4
Electrical Schematic (Standard - Air Cooled) .....	5-5
Electrical Schematic (CE - Water Cooled) .....	5-6
Air Cooled Condenser Electrical Schematic (Kramer).....	5-7
Air Cooled Condenser Electrical Schematic (KeepRite).....	5-8
Lowside Control Panel Layout .....	5-10

## ***Electrical Controls - Section 5 (Continued)***

Condensing Unit Electrical Schematic (Standard) .....	5-11
Condensing Unit Control Panel Layout (Standard) .....	5-12
Condensing Unit Electrical Schematic (CE).....	5-13
Condensing Unit Control Panel Layout (CE) .....	5-14

## ***Maintenance - Section 6***

Preventive Maintenance .....	6-1
Preventive Maintenance Program .....	6-2
Air Cooled Condenser Cleaning .....	6-3
Compressor Oil .....	6-3
Chopper Gear Reducer Oil .....	6-4
Water Distributor .....	6-4

## ***Troubleshooting - Section 7***

Machine Fault Light .....	7-1
Control Power Light .....	7-1
Machine Fault Table .....	7-1
PLC .....	7-2
Damaged Bin Control Sensor .....	7-2
Machine Inoperative .....	7-3
Machine “Freeze-Up” .....	7-4
Additional Troubleshooting .....	7-5

## ***Service Operations - Section 8***

Principle Of Operation .....	8-1
Pressure Switches .....	8-2
CoreSense (Copeland Compressor Protection).....	8-3
Bin Control (Electronic Temperature Control).....	8-4
PLC (Programmable Logic Controller).....	8-5
Compressor.....	8-6
TXV & Solenoid Valve .....	8-7
Adjusting TXV.....	8-8
Inlet Pressure Regulator .....	8-9
Water Distributor / Tank Parts .....	8-10
Chopper Assembly .....	8-11
Evaporator Housing Covers .....	8-12
Freeze Cycle Piping Schematic (No Hot Gas Loop) .....	8-13
Harvest Cycle Piping Schematic (No Hot Gas Loop) .....	8-14
Freeze Cycle Piping Schematic (With Hot Gas Loop) .....	8-15
Harvest Cycle Piping Schematic (With Hot Gas Loop) .....	8-16
Freeze Cycle Piping Schematic (With Suction Stop Valve) .....	8-17
Harvest Cycle Piping Schematic (With Suction Stop Valve) .....	8-18
Replacement Parts List .....	8-19

## ***Options and Accessories - Section 9***

Voltage Monitor (Wagner Model DTP-3) .....	9-1
Remote Switch (Includes Ice/Off/Clean selector switch, start button & fault light) .....	9-3
Remote Switch Box Wiring Schematic.....	9-4

## **1. General Information**

### **HISTORY OF COMPANY**

Henry Vogt Machine Co. was founded as a small machine shop in Louisville, Kentucky in 1880. In 1938, Vogt built the first Tube-Ice® machine and revolutionized the ice-making industry. Our first “sized-ice” machine quickly replaced the old can-ice plants, which required much hard labor and large amounts of floor space for freezing, cutting, and crushing ice by hand.

Today, Vogt Ice®, LLC carries on the tradition as one of the world’s leading producers of ice-making equipment.

**Preview** Vogt® VT Series ice machines are built with the skill in engineering and fabrication that we have learned in over a century of ice machine manufacturing.

Furnished with your machine is the “Certificate of Test”--the report of operating data that is a record of the unit’s satisfactory operation on our factory test floor.

This manual is designed to assist you in the installation, start-up, and maintenance of your unit. Your VT® machine will give you many years of service when you install it, maintain it, and service it properly.

Please read your manual carefully before attempting installation, operation, or servicing of this piece of equipment.

If you have additional questions, please call your distributor. Also, feel free to phone the factory direct at **(502) 635-3000** or **1-800-853-8648**.

**Receipt Of Your Ice Machine**

<b>! CAUTION !</b>
<b>Only service personnel experienced in refrigeration and qualified to work on high amperage electrical equipment should be allowed to install or service this VT ice machine.</b>
<b>Eye protection should be worn by all personnel working on or around the VT machine.</b>
<b>It is very important that you are familiar with and adhere to all local, state, and federal, etc. ordinances and laws regarding the handling, storing, and use of R404A.</b>
<b>! CAUTION !</b>

**Inspection.** As soon as you receive your machine, inspect it for any damage. If damage is suspected, note it on the shipper's papers (i.e., the trucker's Bill of Lading). **Immediately** make a separate written request for inspection by the freight line's agent. Any repair work or alteration to the machine without the permission of the Vogt Ice can void the machine's warranty. You should also notify your Vogt distributor or the factory.

**Safety Tags and Labels.** Be sure to read and adhere to all special tags and labels attached to valves or applied to various areas of the machine. They provide important information necessary for safe and efficient operation of your equipment.

## **2. Installation Information**

**Important Safety Notice.** This information is intended for use by individuals possessing adequate backgrounds of electrical, refrigeration and mechanical experience. Any attempt to repair major equipment may result in personal injury and property damage. The manufacturer or seller cannot be responsible for the interpretation of this information, nor can it assume any liability in connection with its use.

**Special Precautions To Be Observed When Charging Refrigeration Systems.** Only technically-qualified persons, experienced and knowledgeable in the handling of refrigerant and operation of refrigeration systems, should perform the operations described in this manual. All local, federal, and EPA regulations must be strictly adhered to when handling refrigerants.

If a refrigeration system is being charged from refrigerant cylinders, disconnect each cylinder when empty or when the system is fully charged. A gage should be installed in the charging line to indicate refrigerant cylinder pressure. The cylinder may be considered empty of liquid R404A refrigerant when the gage pressure is 25 pounds or less, and there is no frost on the cylinder. Close the refrigerant charging valve and cylinder valve before disconnecting the cylinder. Loosen the union in the refrigerant charging line--carefully to avoid unnecessary and illegal release of refrigerant into the atmosphere.

<b>! CAUTION !</b>
--------------------

<p><b>Immediately close system charging valve at commencement of defrost or thawing cycle if refrigerant cylinder is connected. Never leave a refrigerant cylinder connected to system except during charging operation. Failure to observe either of these precautions can result in transferring refrigerant from the system to the refrigerant cylinder, over-filling it, and possibly causing the cylinder to rupture because of pressure from expansion of the liquid refrigerant brought on by an increase in temperature.</b></p>
--

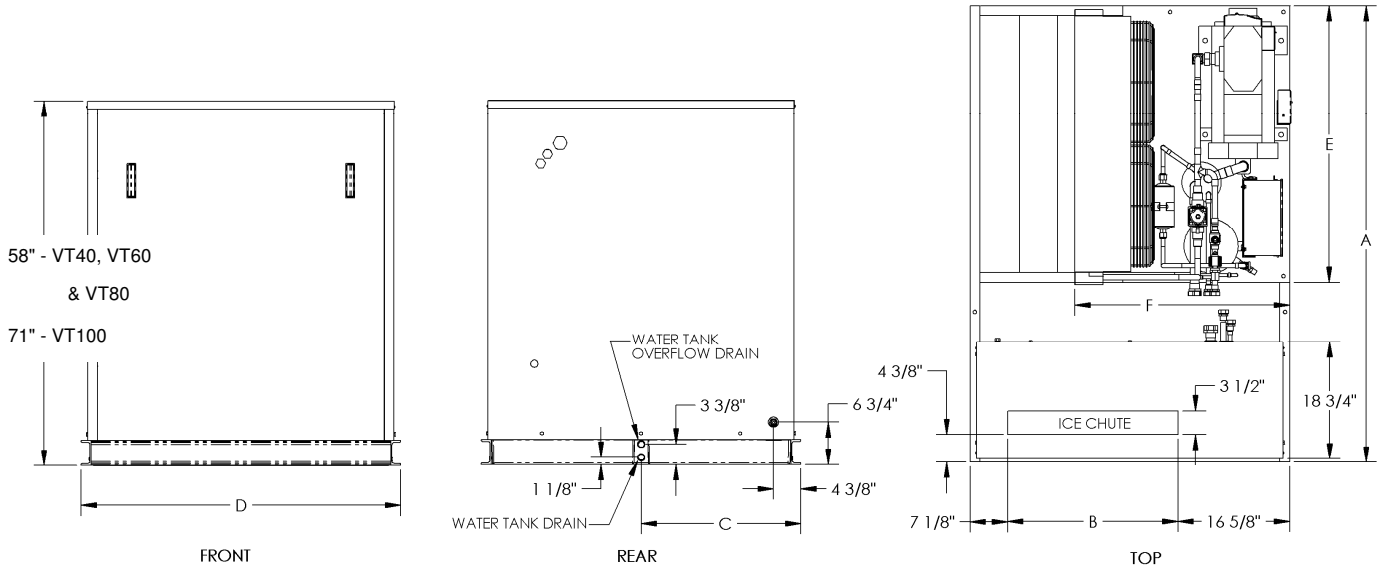
<b>! CAUTION !</b>
--------------------

Always store cylinders containing refrigerant in a cool place. They should never be exposed to temperatures higher than 110°F and should be stored in a manner to prevent abnormal mechanical shocks. Also, transferring refrigerant from a refrigeration system into a cylinder can be very dangerous and is not recommended.

<b>! CAUTION !</b>
--------------------

<p><b>It is not recommended that refrigerant be transferred from a refrigeration system directly into a cylinder. If such a transfer is made, the refrigerant cylinder must be an approved, CLEAN cylinder--free of any contaminants or foreign materials--and must be connected to an approved recovery mechanism with a safety shutoff sensor to assure contents do not exceed net weight specified by cylinder manufacturer or any applicable code requirements.</b></p>
---

<b>! CAUTION !</b>
--------------------



**FIGURE 2-1**  
**Ice Machine Dimensions**

Unit	"A"	"B"	"C"	"D"	"E"	"F"
VT40	72 5/8"	27"	24 3/8"	50 3/4"	44"	34"
VT60	89"	39 1/2"	30 1/2"	63 1/4"	57.5"	68"
VT100	44 7/8"				N/A	N/A

**TABLE 2-1**  
**Ice Machine Dimensions**

Remote Weights			Skid Mounted Weights	
Model	Lowside	Condensing Unit	Model	Skid Mounted
VT40	520 lbs.	975 lbs.	VT-40	1,525 lbs.
VT60	650 lbs.	1330 lbs.	VT-60	2290 lbs.
VT100	1,850 lbs.	400 lbs. (condenser)	VT-100	-----

**TABLE 2-2**  
**Weight Of Machines**

Model	Suction Line	Hot Gas Line	Liquid Line	Remote Condenser	
				Discharge	Liquid Return
VT40	1 3/8 OD	7/8 OD	5/8 OD	N/A	N/A
VT60		1 1/8 OD	7/8 OD		
VT100	1 5/8 OD			1 3/8 OD OD	7/8 OD

Note: Split systems will be supplied with Rota-lock adapters to connect the highside to the lowside

**TABLE 2-3**  
**Refrigerant Line Sizes**

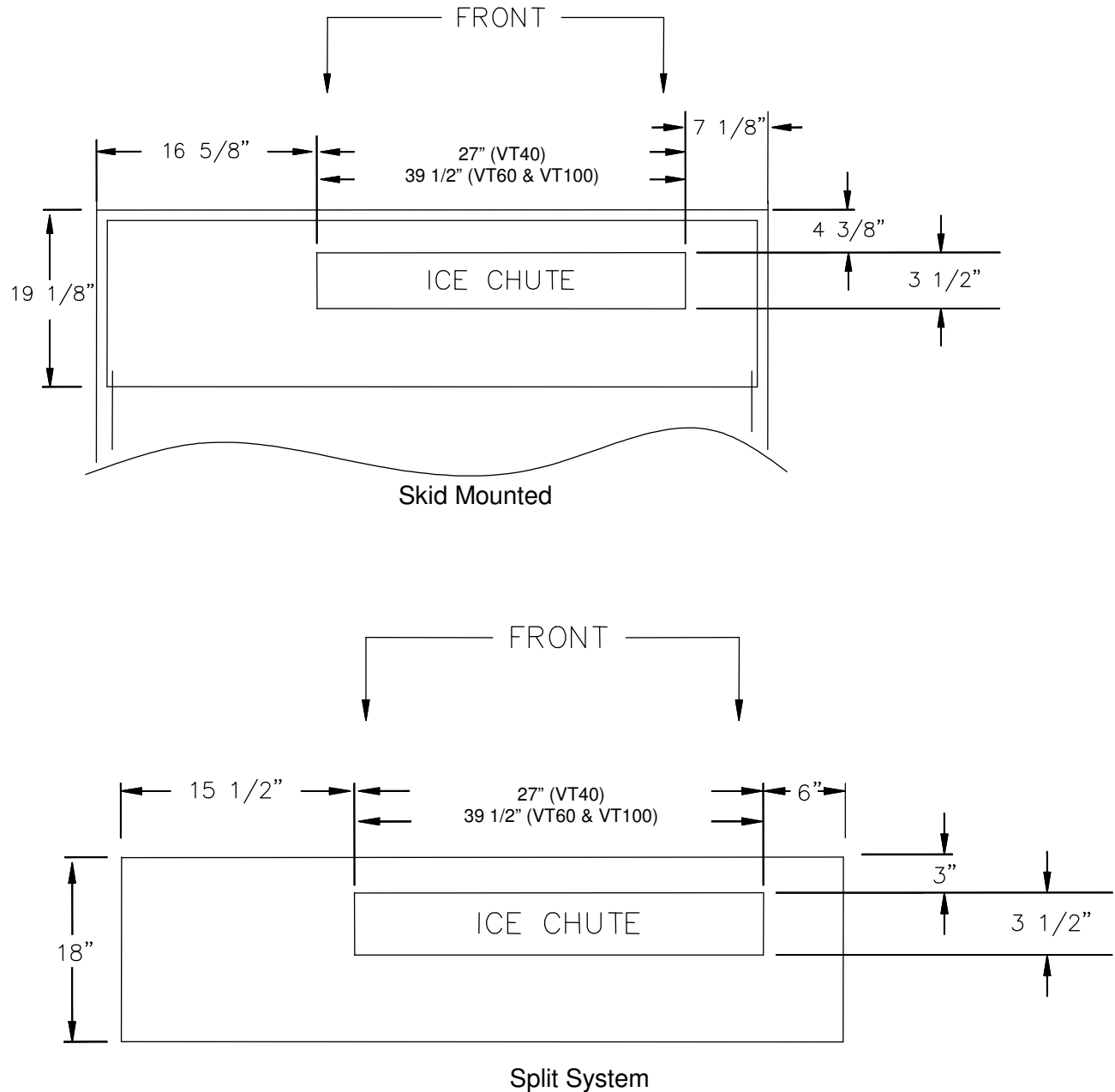
**Machine Clearances:** A minimum three (3) feet of clearance is recommended around entire ice machine. This will provide sufficient area for service and air flow.

**Evaporator Installation:** Mount evaporator section (lowside) on storage area capable of sustaining its weight and secure by thru bolting.

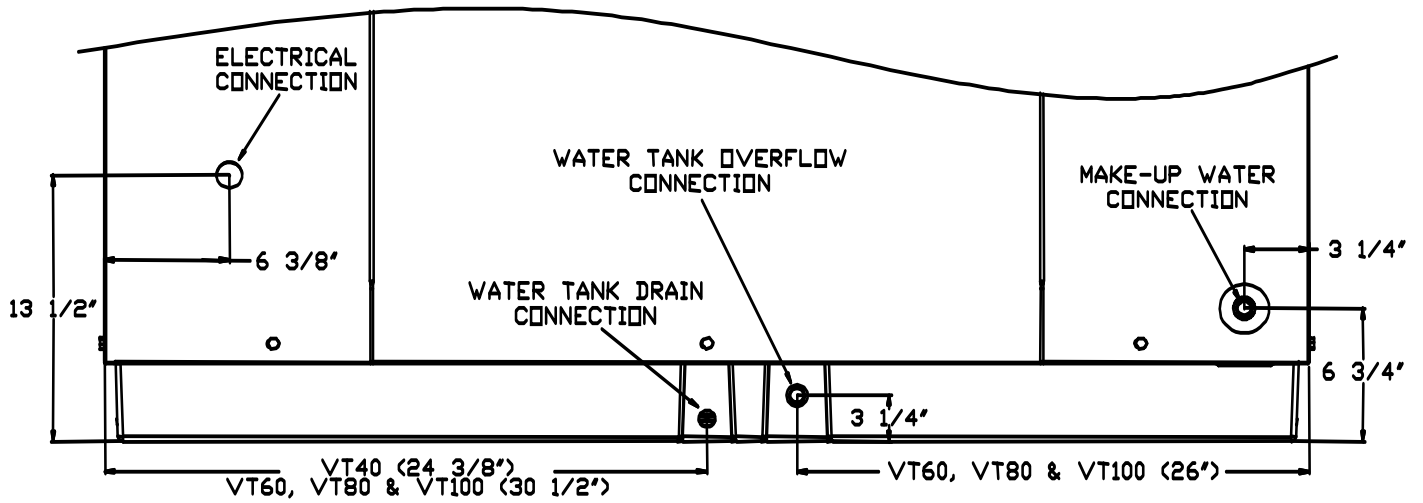
**Note:** Ambient at the lowside should remain between 50°F–105°F. Makeup water temperature should not drop below 40°F. Machine may experience problems if operated outside of these ranges.

**Piping Installation:** Use ACR refrigeration tubing and nitrogen purge during brazing to prevent formation of copper oxide. For piping runs exceeding 25', consult a reliable piping manual (Copeland, Heatcraft, or Vilter) for proper pipe sizing. Heat sink all ball valves and remove Schrader valve core prior to brazing. Pressure test piping for leaks. Evacuate lines to 500 microns prior to starting machine.

**Chute Location:** Using drawing and table below, determine ice machine location so that it is centered on bin. Place ice machine on ice storage unit and bolt in place. **Machine must be level front to back and side to side for proper operation.**



**FIGURE 2-2**  
**Ice Chute Cutout Location**



NOTE: VT40 OVERFLOW CONNECTION DIRECTLY ABOVE TANK DRAIN CONNECTION

Makeup water, water tank drain and water tank overflow are 1/2" FPT connections

**FIGURE 2-3**  
**VT Lowside Water and Electrical Connections – Rear View**

<b>Makeup Water Flow</b>	<b>VT40</b>	<b>VT60</b>	<b>VT100</b>
Usage - Gallons /100 lbs of Ice	12	12	12
Flow rate – Gallons / minute	0.38	0.54	0.80
Flow rate – Gallons / hour	22.5	32.5	48.0
Water Tank Capacity – Gallons	6	7	

**Note:** Water usage and flow rates base on 70°F water with no blowdown

**TABLE 2-4**  
**MakeUp Water Requirements / Flow Rates**

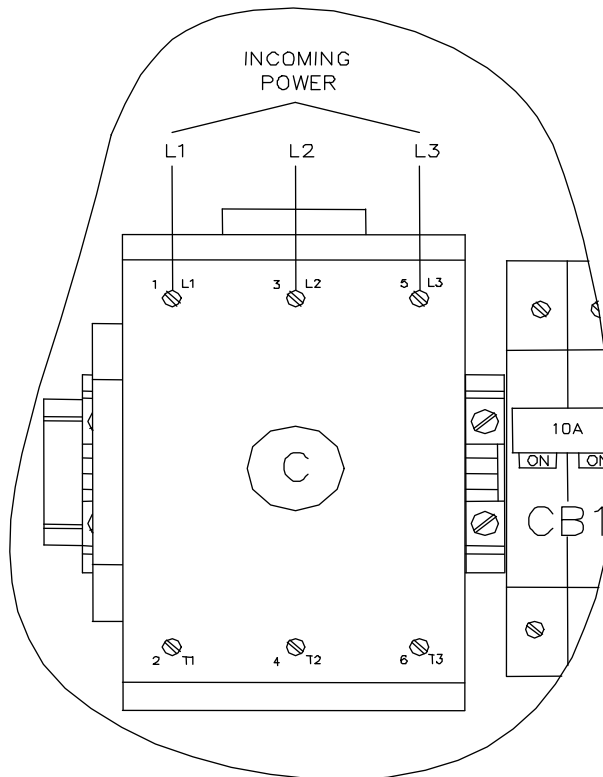
Wiring And Electrical Connection.

<b>! WARNING !</b>
<b>Only service personnel experienced in refrigeration and qualified to work with high voltage electrical equipment should be allowed to install or work on the Vogt® VT Series Ice machine.</b>
<b>! WARNING !</b>

**Main Power:** Power for the entire ice machine will be supplied at the condensing unit. Refer to the table below to properly size wiring connections. **A fused disconnect switch must be provided** near the condensing unit of the ice machine. Connect 3 phase power to compressor contactor L1, L2, L3 for operation of the VT ice machine and its controls. If one phase (leg) of the 3 phase power is higher or lower (“Wild”), it should be connected to terminal #L2. Connect the “Ground” wire to the “Ground” terminal provided.

Electrical Data	VT40	VT60	VT100			
			208/230-3-60		460-3-60	
			Kramer	KeepRite	Kramer	KeepRite
Total F.L.A.	46.1	56.4	80.6	79.9	38.7	40.0
Minimum Circuit Ampacity	54.0	66.9	97.1	95.9	47	48
Maximum Fuse Size	85	110	165		80	

**TABLE 2-5**  
**Electrical Requirements**



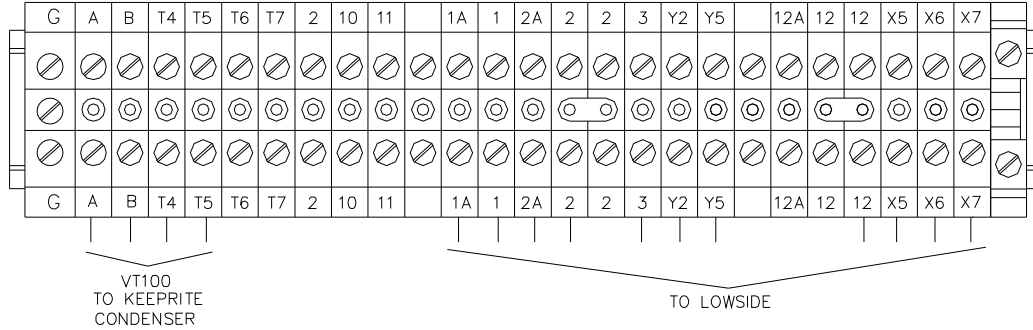
**FIGURE 2-4**  
**Main Power Connection**

## 2-6

### Installation Instructions

**Air Cooled Condenser Wiring (VT100 with KeepRite Condenser) :** Run four #14 AWG wires from the terminals A, B, T4 and T5 on the condensing unit control panel terminal block to the air cooled condenser control panel.

Standard Voltage Machine  
200/230V or 400/460V, 3PH, 50/60HZ

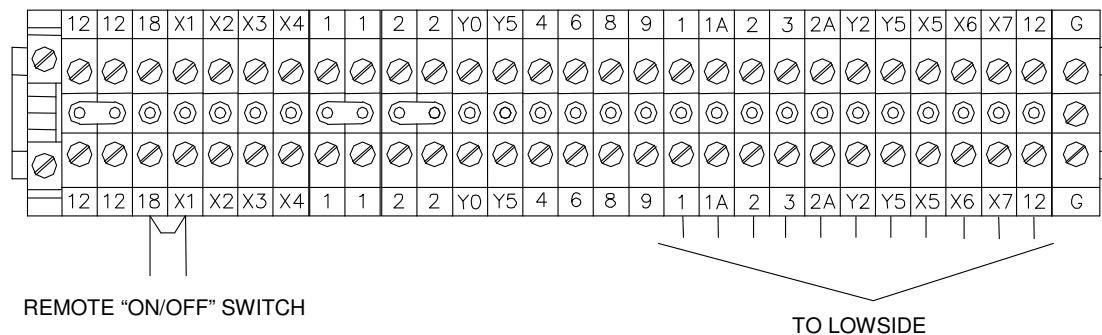


**FIGURE 2-5**  
**Condensing Unit Terminal Blocks**

**Lowside Electrical Connections:** Run 11 #14 AWG or larger wires run from the Lowside control panel terminal block to the condensing unit (highside) control panel terminal block.

Number of wires	Wire Size (AWG)	Wire #
5	16 (Red)	1, 2, 3, Y2, Y5
4	16 (Blue)	X5, X6, X7, 12
2	14 (Black)	1A, 2A
1	14 (Green)	GND

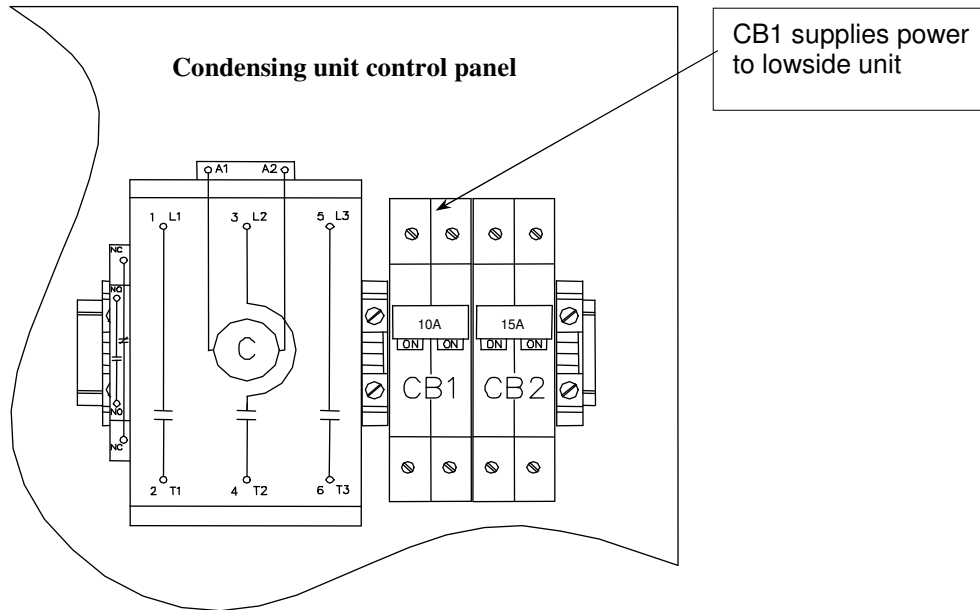
**TABLE 2-6**  
**Lowside to Highside Wire**



**FIGURE 2-6**  
**Lowside Unit Terminal Block**

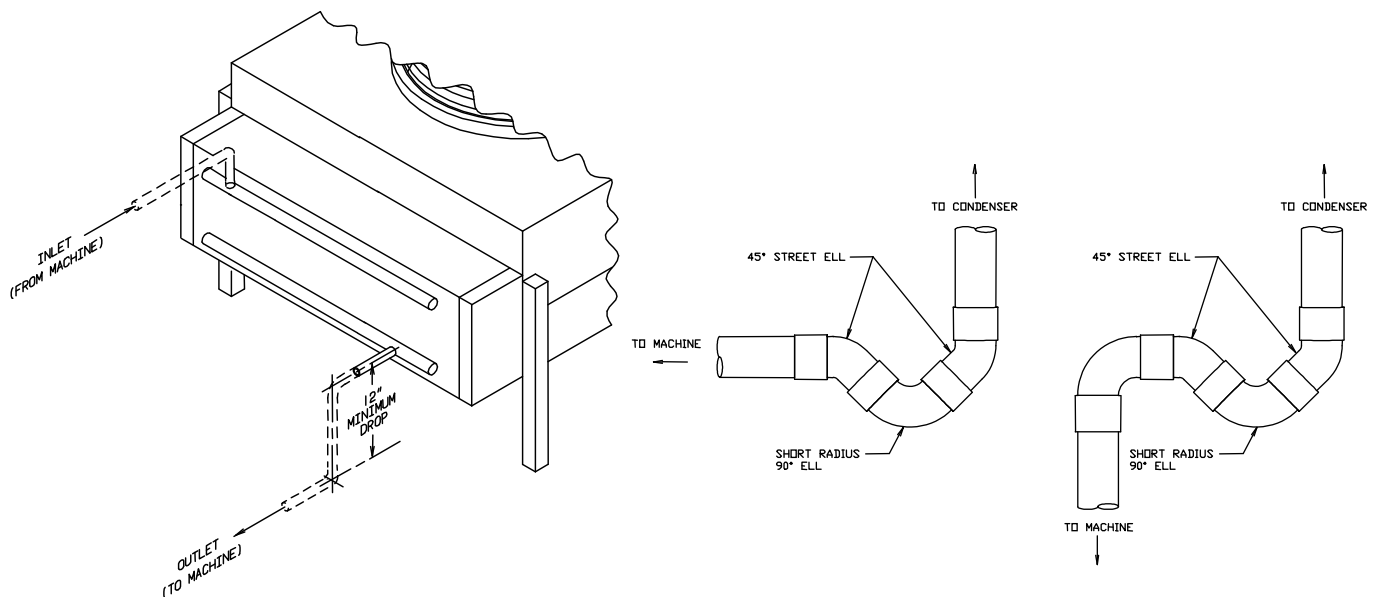
**Note:** Machine is supplied with a remote "on/off" connection on the lowside terminal block. If a remote "On/Off" switch is used, remove jumper between #18 & #X1 and connect switch to these terminals.

Power is supplied to the lowside through circuit breaker (CB1) located in the condensing unit control panel. See diagram below.



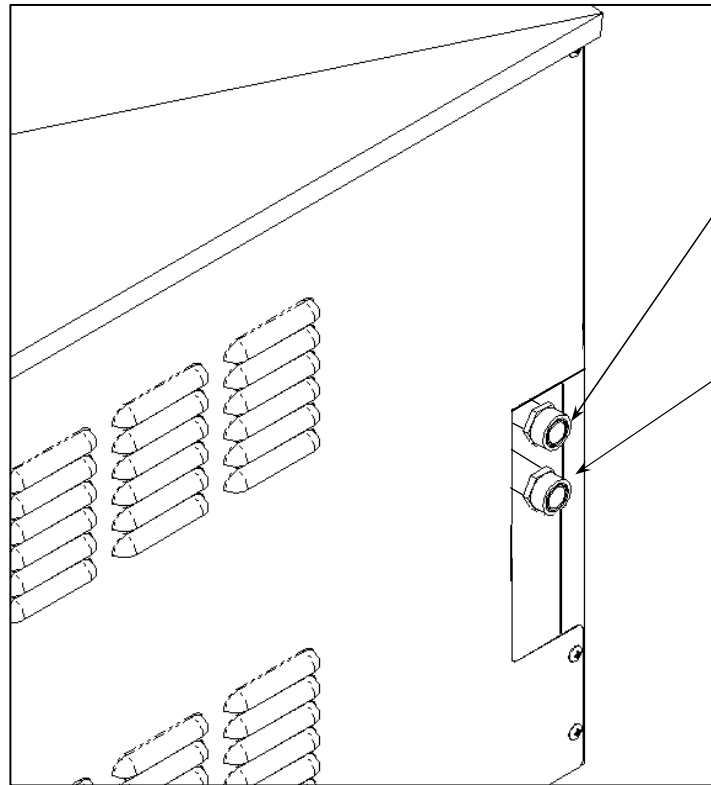
**FIGURE 2-7**  
Condensing Unit Circuit Breakers (200/230V)

**Air Cooled Condenser Installation (VT100):** Ice making systems with remote condensers are trapped internally. A trap leaving the compressor is not necessary. On vertical runs a short radius “P” trap should be installed every 15’ to 20’ of vertical rise to facilitate oil flow. Horizontal runs should be sloped in direction of refrigerant flow 1” for every 20’ of run. The condenser should be securely mounted in a place capable of sustaining its weight.



**FIGURE 2-8**  
Condenser Piping (VT100) and Recommended Traps

Must solder with 45% silver solder

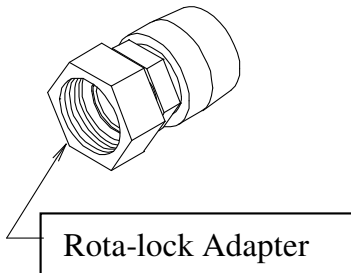


Liquid return from  
Air Cooled Condenser  
(7/8" line)

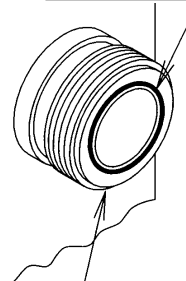
Discharge gas to  
Air Cooled Condenser  
(1 3/8" line)

Female Rota-lock Adapters:  
**12A2396A0701** – for 1 1/4"-12 F x 7/8" Sweat (Solder)  
(Return Line from condenser)  
**12A2396A0601** – for 1 3/4"-12 F x 1 3/8" Sweat (Solder)  
(Discharge to condenser)

Teflon Seal  
**12A2600T01** (for 1 1/4"-12 thread fitting)  
**12A2600T03** (for 1 3/4"-12 thread fitting)



Rota-lock Adapter

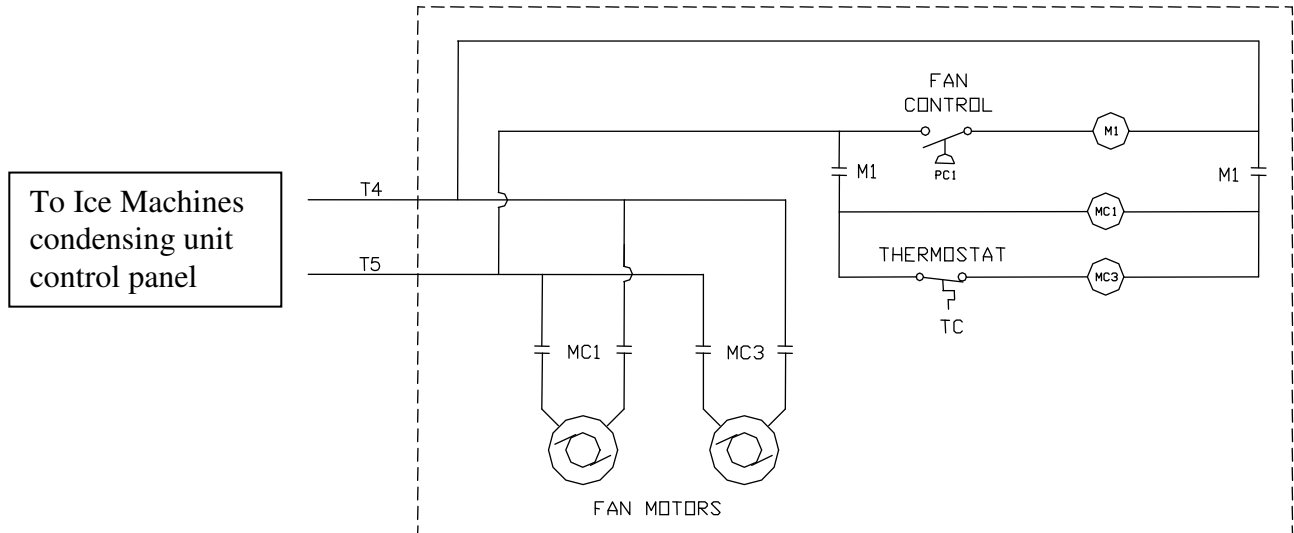


Note: Rota-lock male  
adapter on ice machine

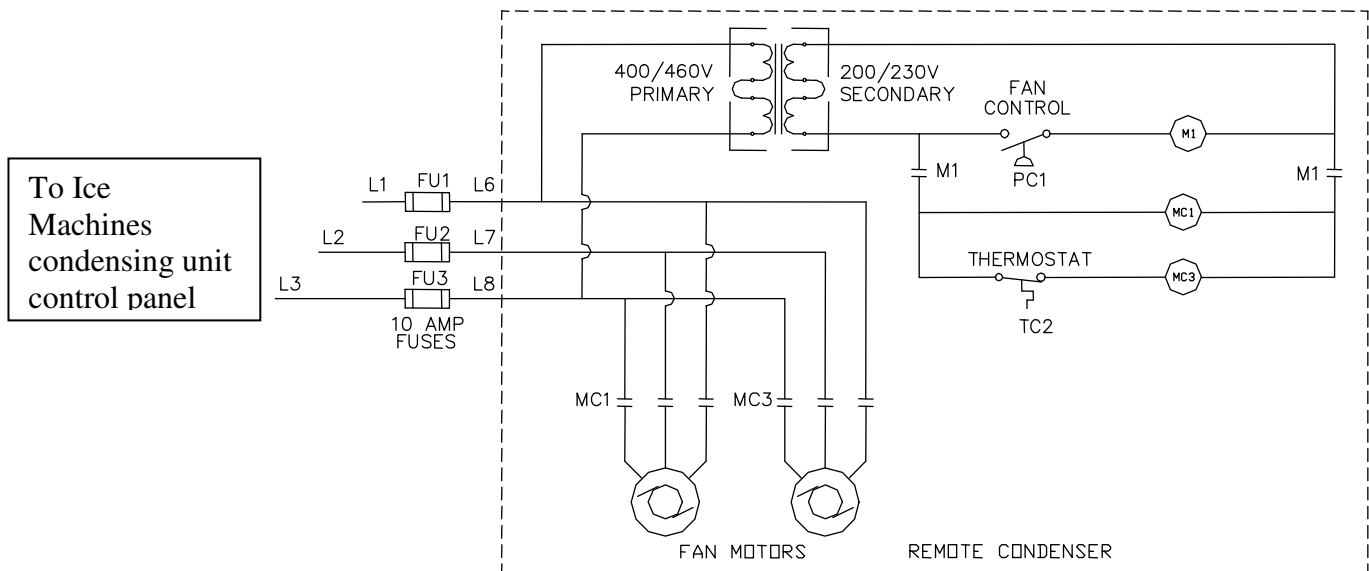
Note: Rota-lock adapters  
supplied with machine

**FIGURE 2-10**  
**VT100 Condenser Refrigerant Line Connections**

**Air Cooled Condenser:** The air cooled condenser will be wired to the condensing unit control panel. Run two #14 AWG wires and a ground wire from the condensing unit control panel to the Air Cooled condenser control panel.



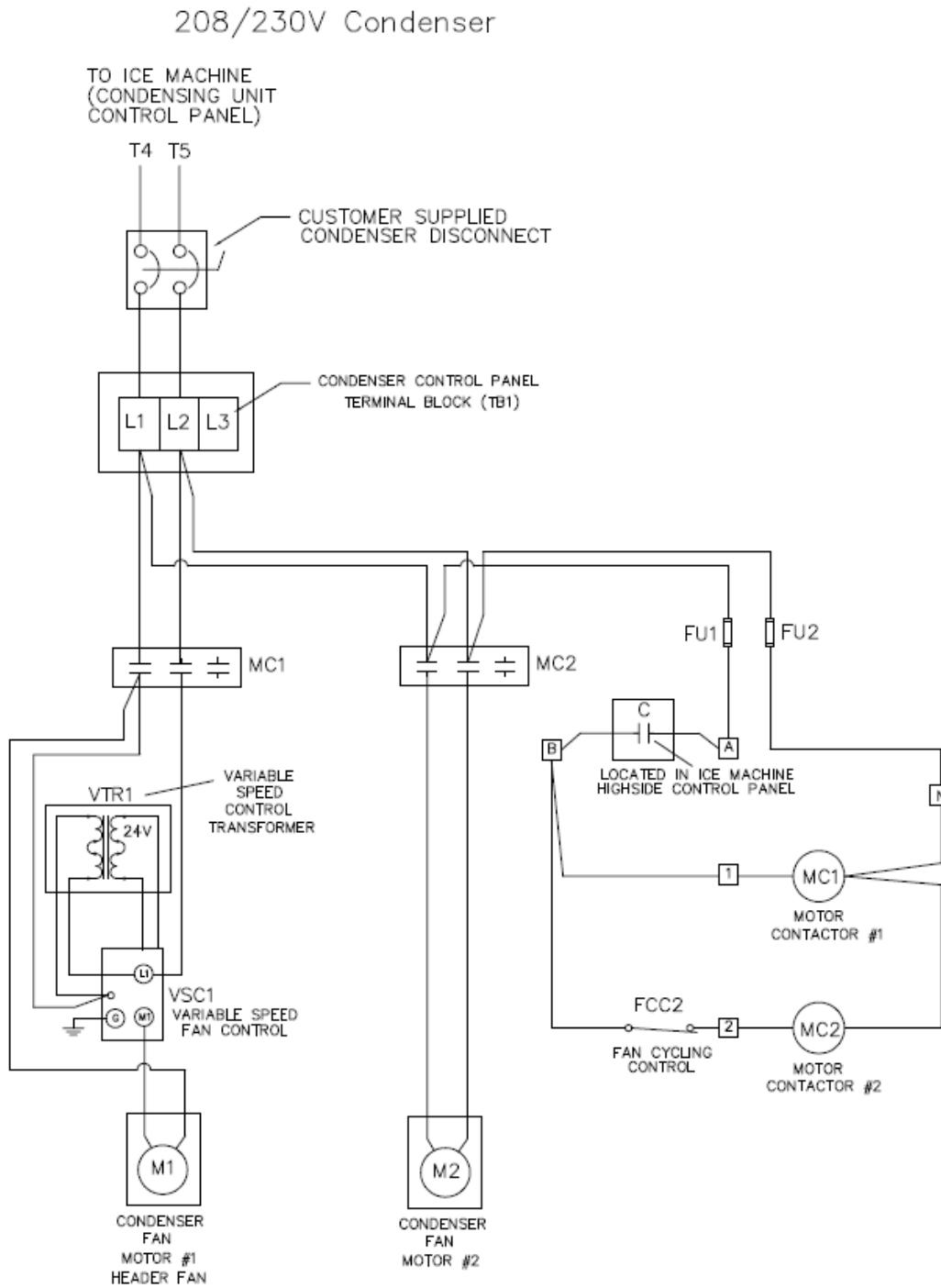
208/230V



460V

**FIGURE 2-11A**  
**Kramer VT100 Remote Air Cooled Condenser Wiring**

**Note:** Fan control pressure switch is located in air cooled condenser control panel on VT100's with remote condensers. On VT40's and VT60's, fan control pressure switch is location on condensing unit (highside).

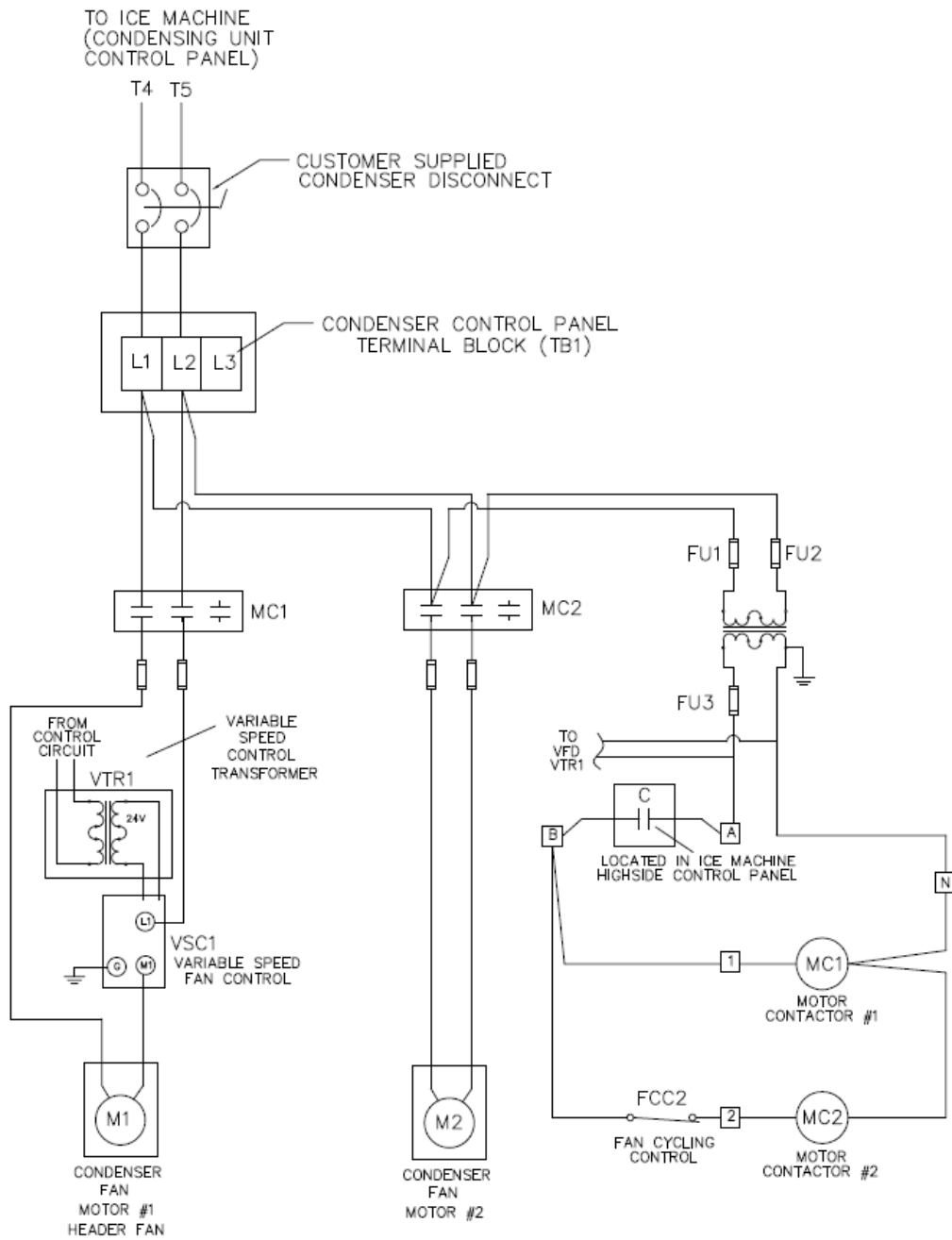


**FIGURE 2-11B**

KeepRite VT100, 200/230V Remote Air Cooled Condenser Wiring

**Note:** Fan cycling switch, FCC2 (Danfoss) for fan motor #2, is not factory set. Switch must be set in the field before startup. Cut Out = 210 psi, Diff = 25 psi. Use an accurate gage to set, not the scale on the pressure switch.

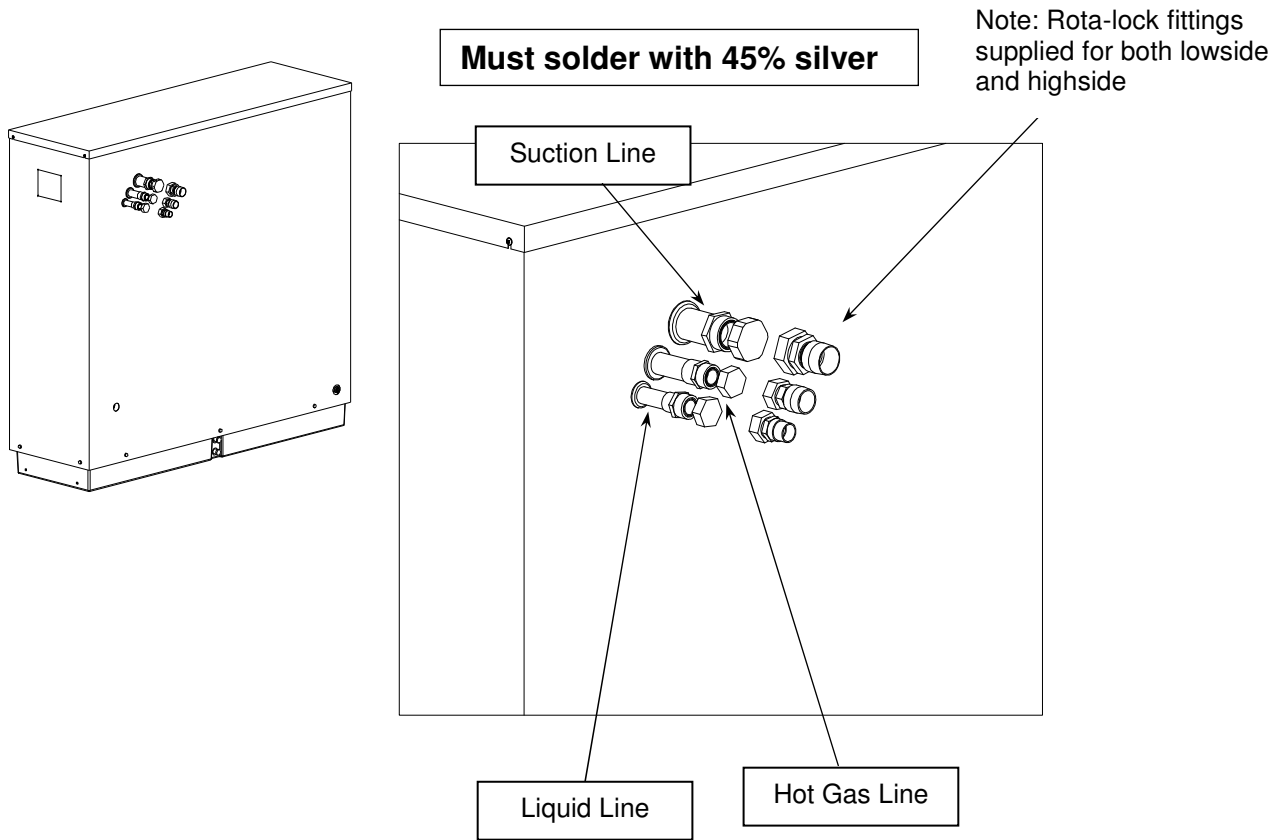
400/460V Condenser



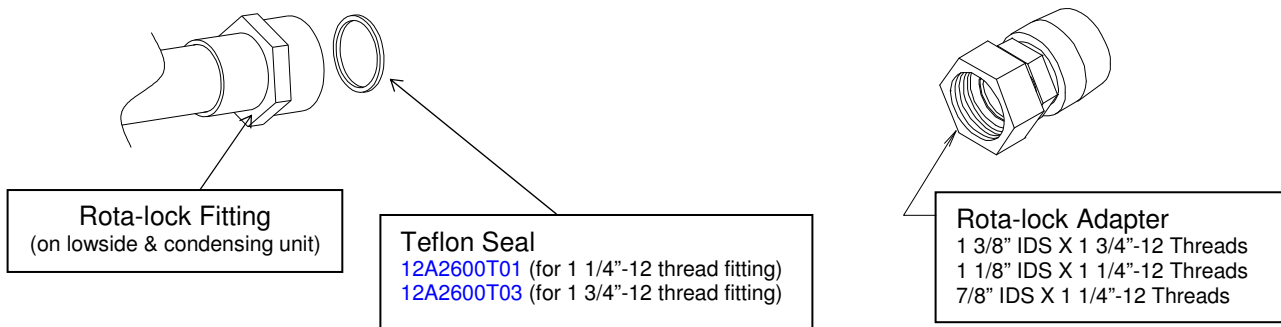
**FIGURE 2-11C**

KeepRite VT100, 400/460V Remote Air Cooled Condenser Wiring

**Note:** Fan cycling switch, FCC2 (Danfoss) for fan motor #2, is not factory set. Switch must be set in the field before startup. Cut Out = 210 psi, Diff = 25 psi. Use an accurate gage to set, not the scale on the pressure switch.



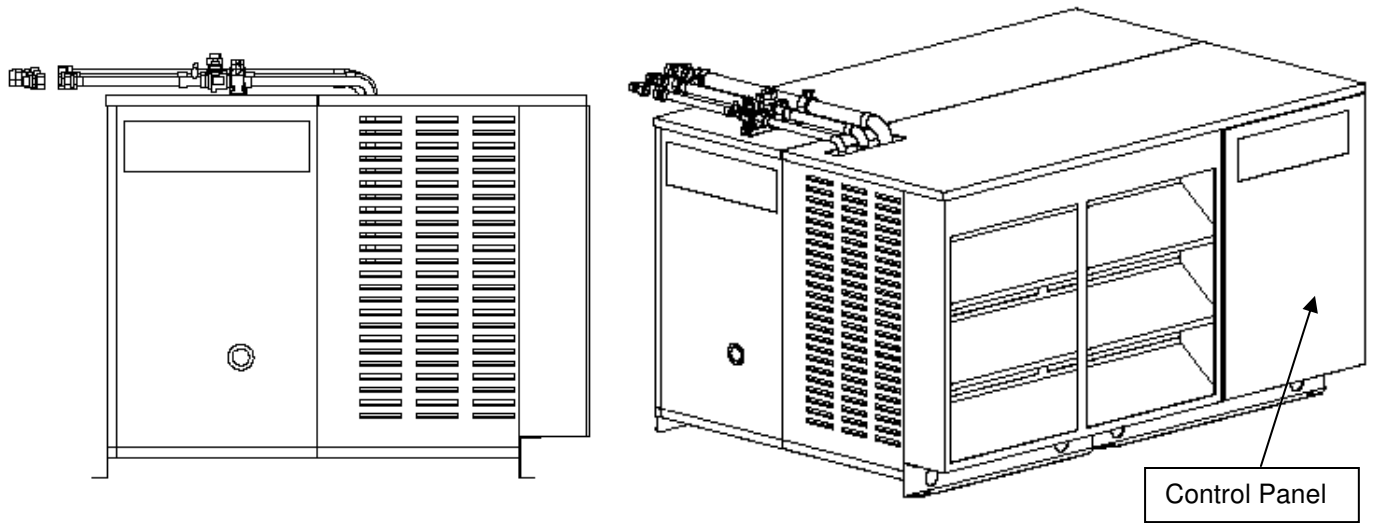
**FIGURE 2-12**  
**VT Lowside Connections**



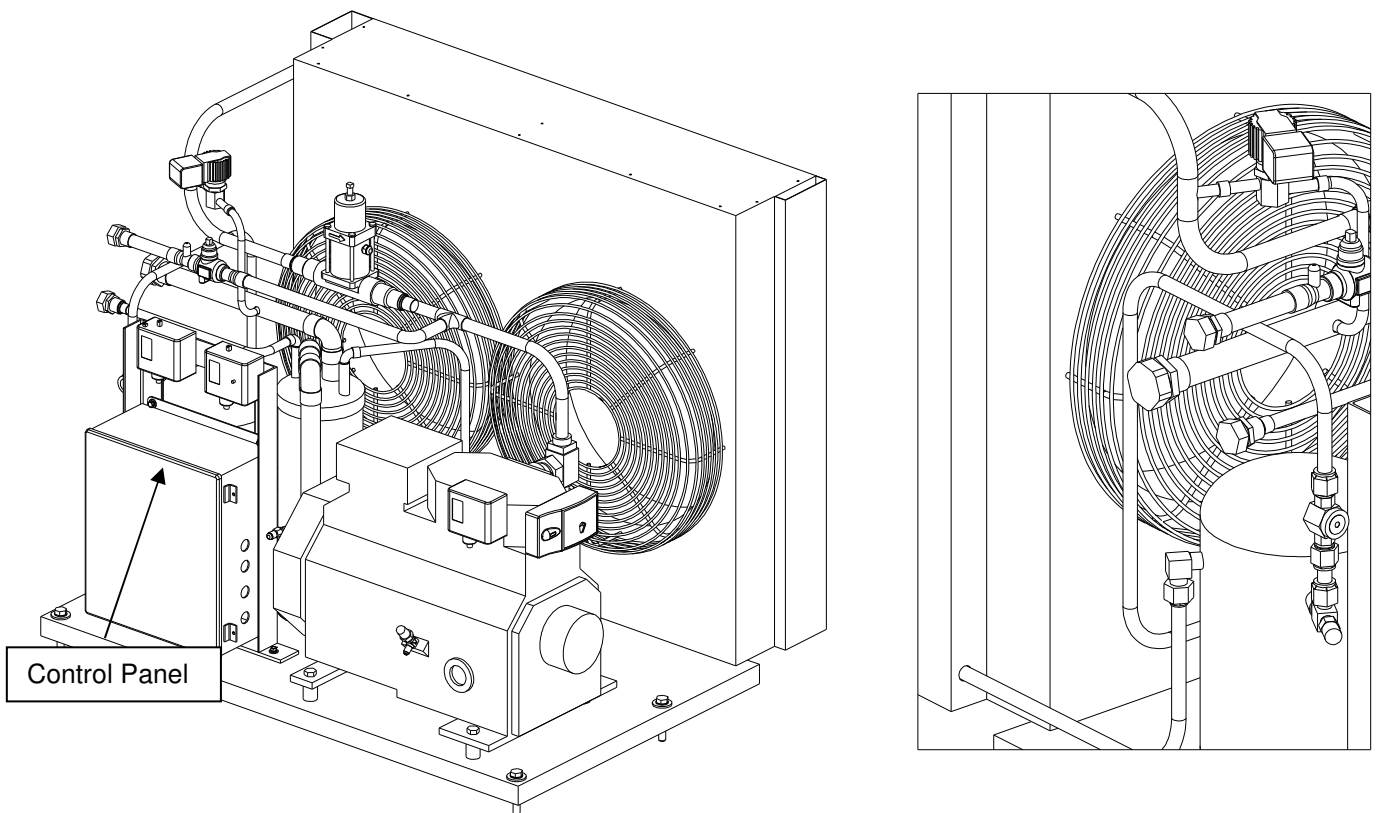
Rota-lock Adapter		Teflon Seal	Where Used	
Part #	Description	Part #	VT40	VT60
12A2396A0501	1 1/8" IDS X 1 1/4"-12Thrd	12A2600T01	N/A	Hot Gas Line
12A2396A0601	1 3/8" IDS X 1 3/4"-12Thrd	12A2600T03	Suction Line	Suction Line
12A2396A0701	7/8" IDS X 1 1/4"-12Thrd	12A2600T01	Liquid & Hot Gas line	Liquid Line

**TABLE 2-5**  
**Rota-lock Adapters**

**Note:** See Refrigerant Line Size TABLE 2-3 for line sizes



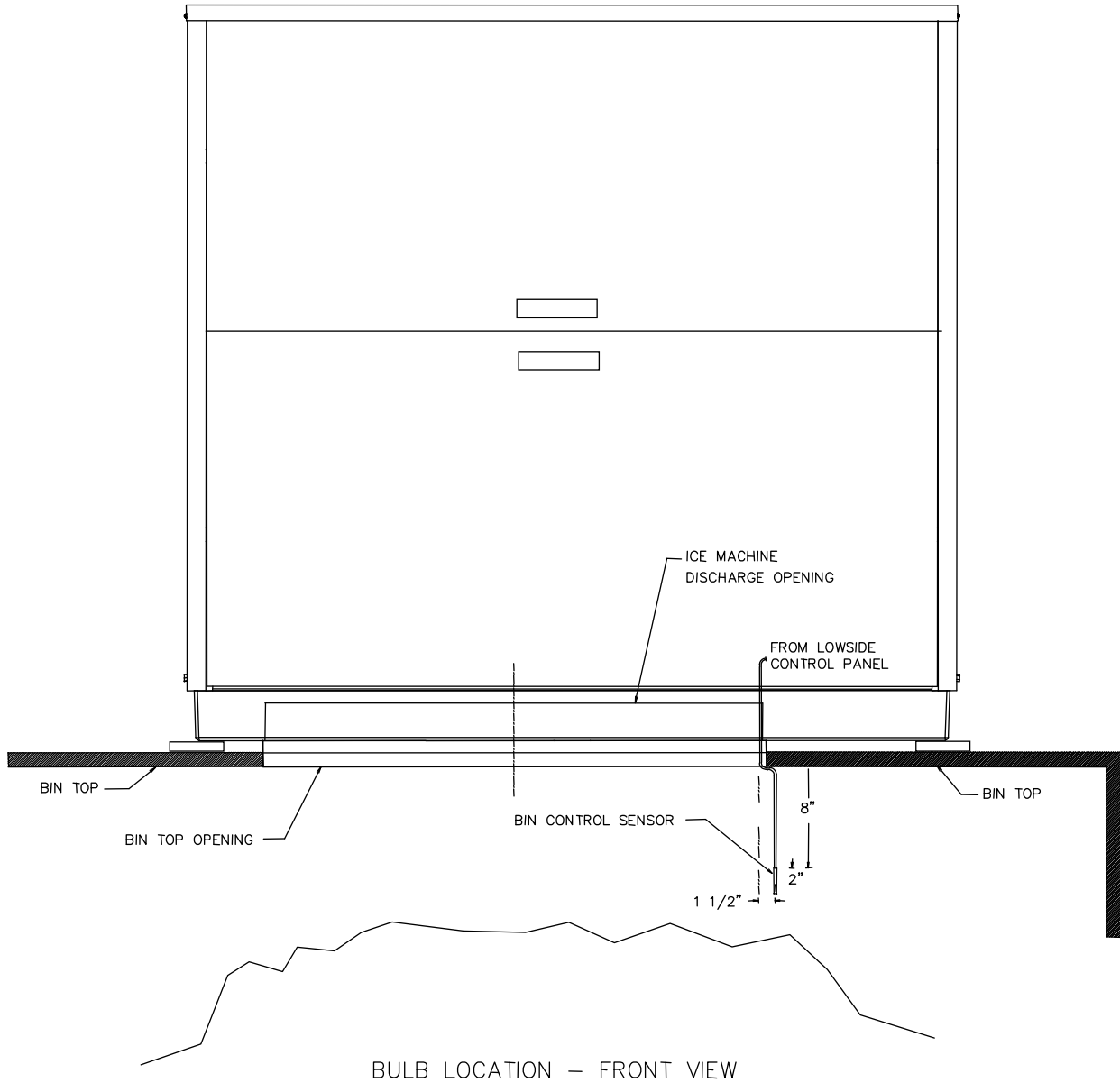
**FIGURE 2-13**  
VT60 Condensing Unit Connections



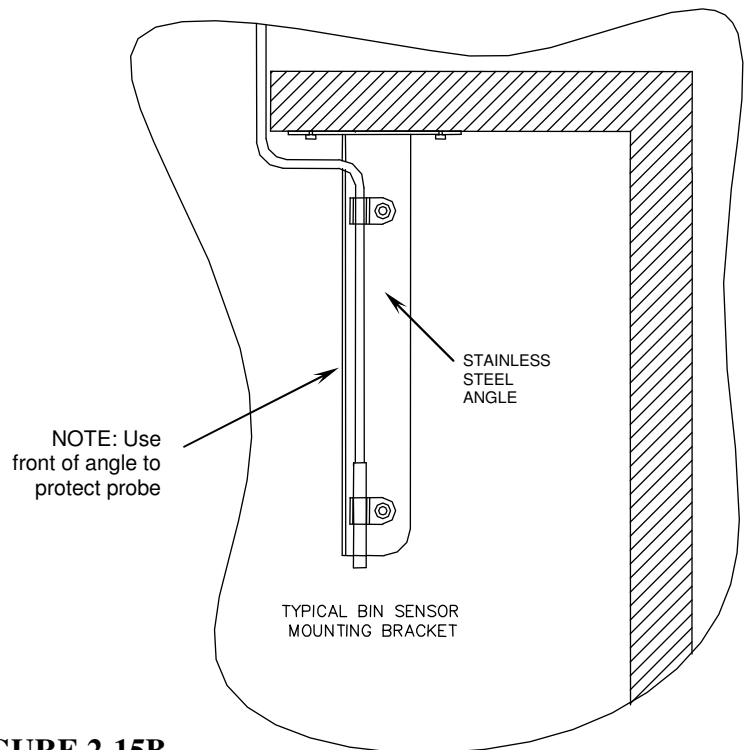
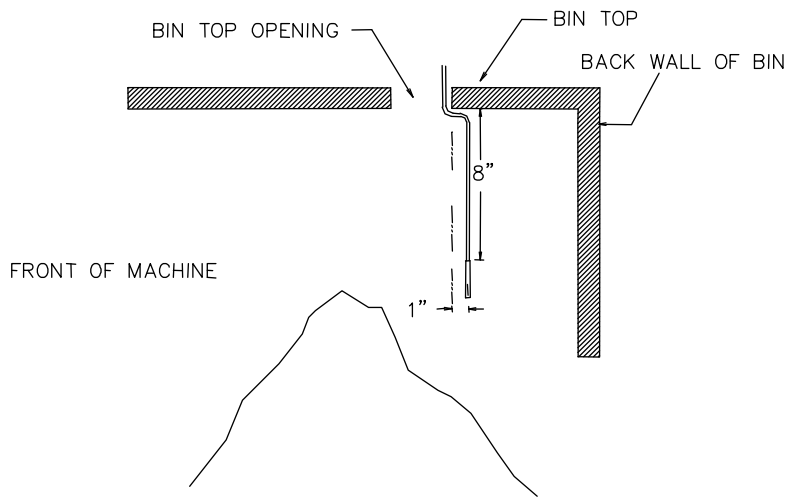
**FIGURE 2-14**  
VT40 Condensing Unit Connections

Installation Instructions

**Storing Ice.** When storing ice in a bin, make sure the bin control sensor is mounted in the bin properly. The sensor should be mounted on the right side of the bin approximately 8" –12" from the top of the bin.



**FIGURE 2-15A**  
**Bin Control Sensor Installation**



**FIGURE 2-15B**  
**Bin Control Sensor Installation**

**Ice Bin Capacity.** Crushed ice weighs approximately 35 pounds per cubic ft. (35 lb/ft<sup>3</sup>). As ice drops into a bin, it will pile up and slope naturally at about a 45° angle. This natural slope should be taken into account when locating the bin thermostat sensor (or other bin level control) and when calculating the normal bin capacity. If the ice is spread out by hand in the bin for maximum storage capacity, make sure a hazard is not created by allowing ice to back up into the chute and jamming the cutter. Always allow enough room below the chute for at least one harvest.

- VT40 = 25-30 lbs. / cycle
- VT60 = 35-40 lbs. / cycle
- VT100 = 47-52 lbs. / cycle

Blank

### 3. Model Specifications

#### Electric

	VT-40	VT-60	VT-100	
			Kramer	KeepRite
Volts/ Phase/ Hertz	208/230-3-60			
Total F.L.A. Rating	46.1	56.4	80.8	79.4
Minimum Circuit Ampacity	54.0	66.9	97.3	95.9
Maximum Circuit Breaker	90	110	165	165

#### Compressor (Copeland® Discus®)

Compressor HP	5.5 HP	7 HP	12.5 HP	
Voltage Range (208/230)	187-253			
Nameplate Amp Rating (RLA)	31.5	42.0	66	
Locked Rotor Amp Rating (LRA)	161.0	215.0	374	
Oil (Suniso) – Mineral (R22)	3GS			
Oil (Copeland) – Synthetic (R404A)	Ultra 32 – 3MAF or Mobil EAL Arctic 22 CC			
Oil – amount (Initial Charge / Recharge - oz)	125 / 115		135 / 125	

#### Chopper Motor (Marathon)

HP	1/2 HP			
Voltage	230 V			
FLA	3.7 A			

#### Water Pump Motor

	Hartell	Anjon (CE approved)		
HP	1/12 HP	1/5 HP (144W)		
Voltage	208-230V	115V		
FLA	0.85 A	1.2A		

#### Condenser Fan Motors

HP	2 @1/2 HP		2 @3/4 HP	
Voltage	208-230 V		208-230 V	
Manufacture (Condenser/Condensing Unit)	Copeland	Kramer	Kramer	KeepRite
FLA (Total for both motors)	8.4 A	8.2 A	8.6 A	7.2 A

#### Field Connections (Remote Condensing Units Only)

Suction	1 3/8 ODS	1 3/8 ODS	N/A	N/A
Hot Gas	7/8 ODS	1 1/8 ODS	1 1/8 ODS	1 1/8 ODS
Liquid	5/8 ODS	7/8 ODS	7/8 ODS	7/8 ODS

#### General Info

Sight Glass (Sporlan)	SA 15U	SA 17S	SA 17S	SA 17S
Filter Drier (Sporlan)	C-415	RC-4864	RC-4864	RC-4864
Refrigerant Charge	16 lbs.	32 lbs.	35 lbs.	40 lbs.
Inlet Water Line	1/2" FPT			
Water Tank Drain & Water Tank Overflow	1/2" FPT			

#### Control Settings (approximate)

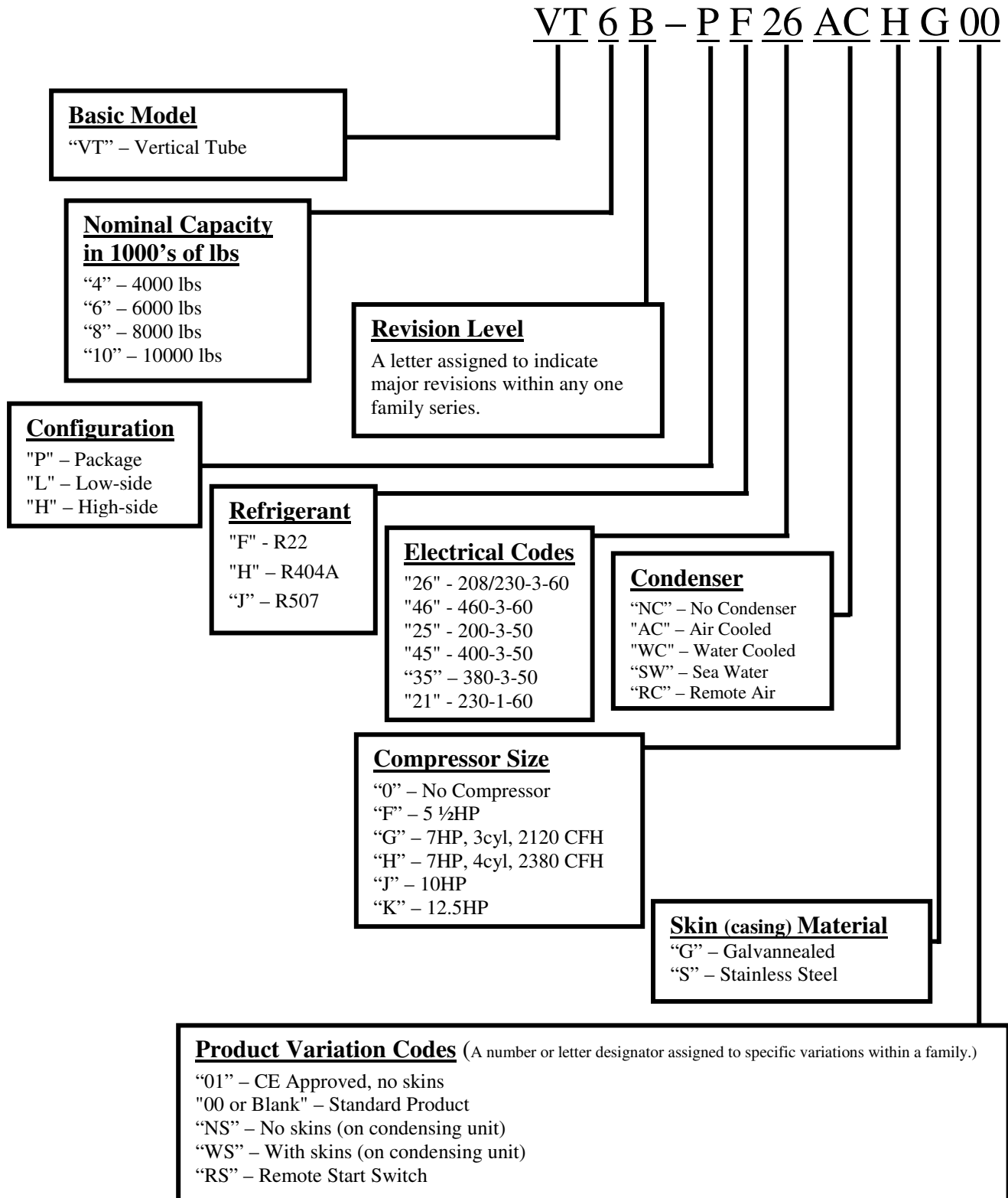
	R22		R404A			
	Johnson Control Switch		Johnson Control Switch		Danfoss Pressure Switch	
	Cut-in	Cut-out	Cut-in	Cut-out	Cut-Out	Diff
Fan Switch (PSIG)	220	200	250	230	210	25
Low Pressure Safety (PSIG)	20	10	20	10	N/A	N/A
Harvest Hold Pressure Control	45	60	65	80		
High Pressure Safety (PSIG)	Manual	300	Manual	350		
Oil Pressure Control (Differential)	9 PSIG (Manual Reset)					

Listed refrigerant charges are for close coupled and skid mounted machines as tested.

Remote installations of extended length will require additional refrigerant.

Note: Electrical data based on air cooled units

## Vogt Ice Vertical Tube Model Number Structure



## 4. Initial Startup

### START-UP PROCEDURE

Prior to start-up, the following items should be checked:

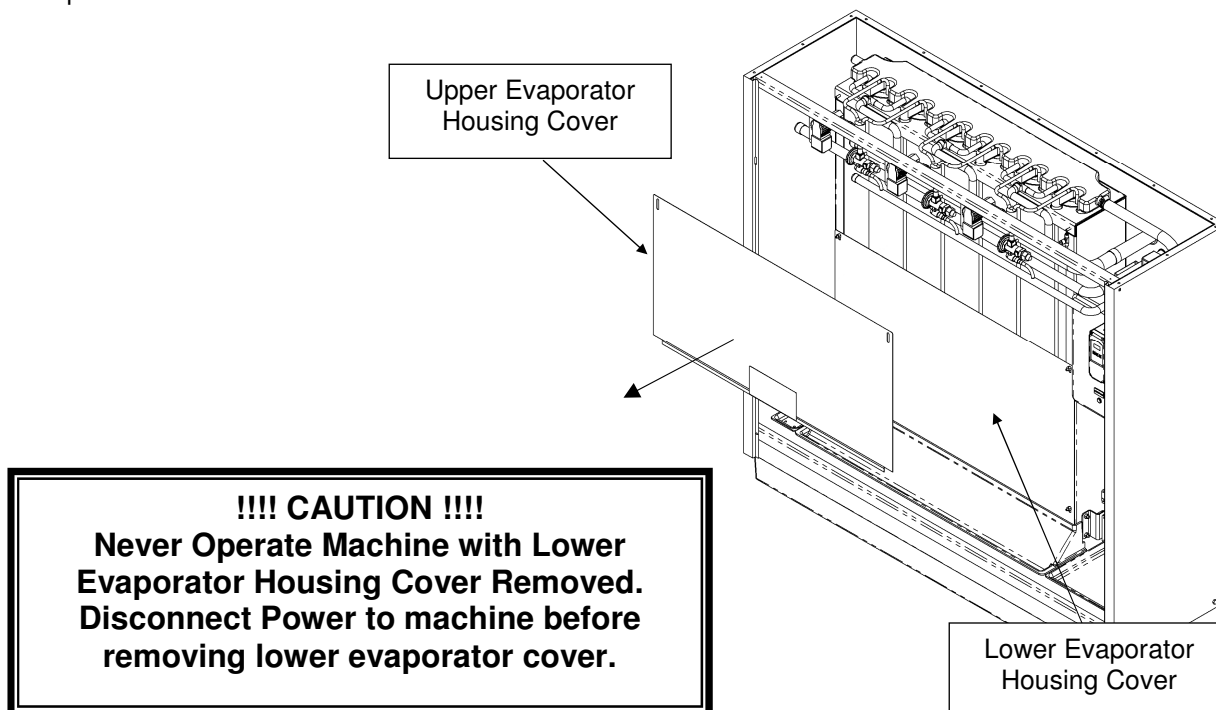
1. Make sure all packing has been removed from the lowside unit. To do this, you must remove the upper and lower evaporator housing covers. Remove to upper casing first, then the lower. (See Figure 4-1)

**CAUTION !!! Make sure Lower Evaporator Housing Cover is put back on machine before power is applied.**

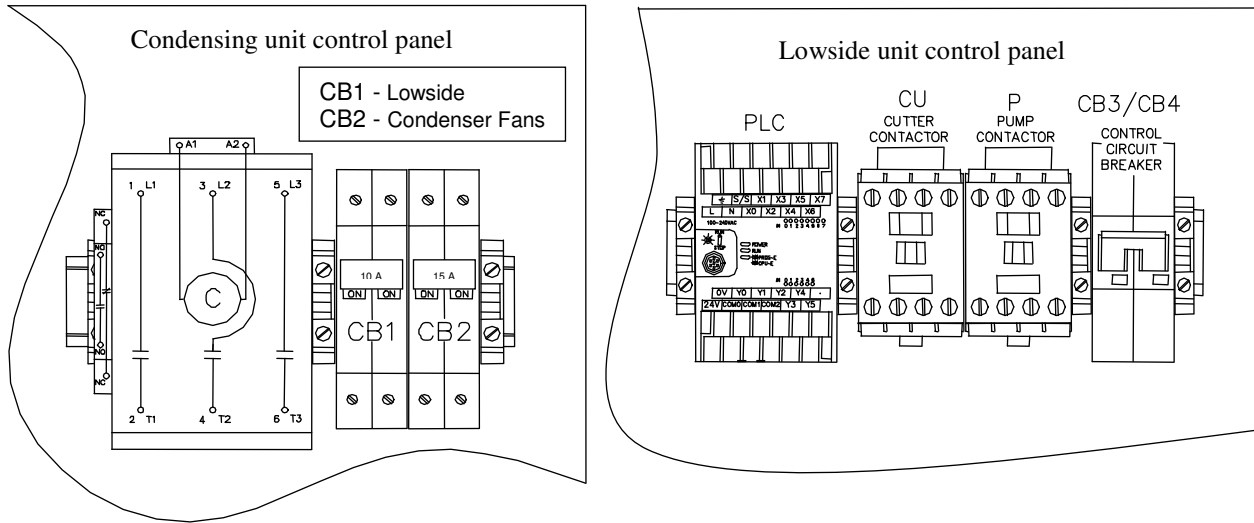
2. Open all service and ball valves. (Figure 4-4 & 4-5)
3. Check that bin switch is installed correctly. (Figure 2-5)
4. Check voltage and verify with nameplate.
5. Verify adequate water supply and water level of two (2") inches.
6. Verify Ice/Off/Clean selector switch on the lowside unit is in the "Off" position.
7. Energize unit two (2) hours prior to starting to energize crankcase heater.
8. Ensure that circuit breakers in condensing unit control panel are in the "on" position. (Figure 4-2)

**Note:** "Control Power" Light will be ON when power is supplied to Lowside

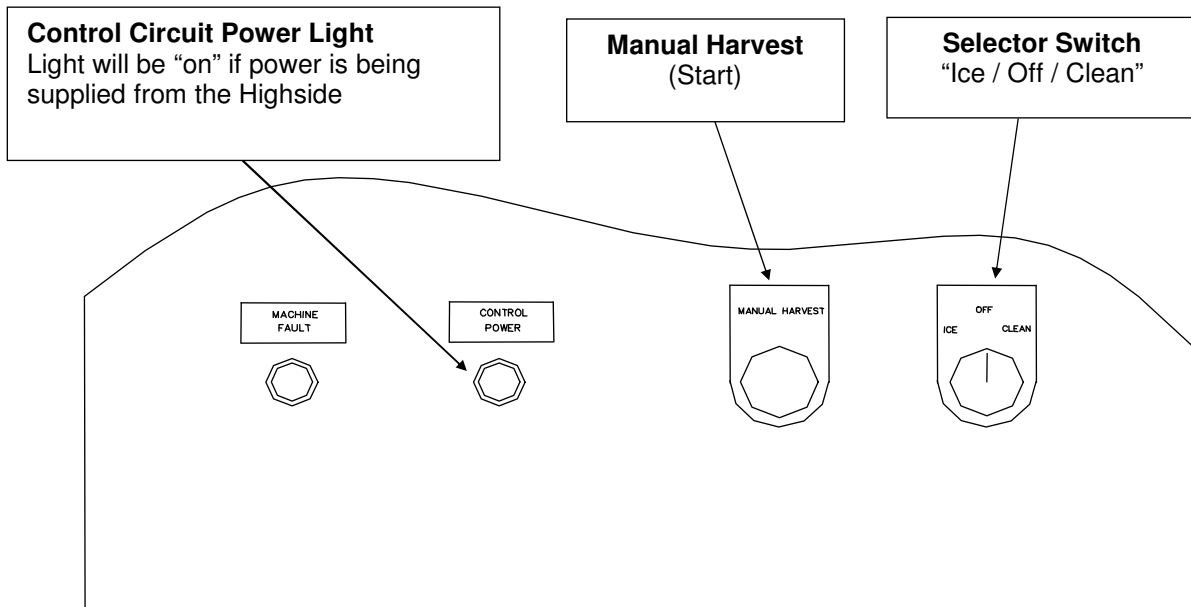
At completion of above eight (8) items, machine is ready to run. Place selector switch in "Clean" position and check water flow. (If the pump does not come on, press the green "Manual Harvest" button). Place selector switch in "Ice" position and press "Manual Harvest" button. The machine will start in a harvest mode then proceed to the Freeze mode. Observe machine operation. Make no changes to any settings on machine for six (6) cycles. Verify pressures settings conform to service manual information. Do not trust pressure control scales.



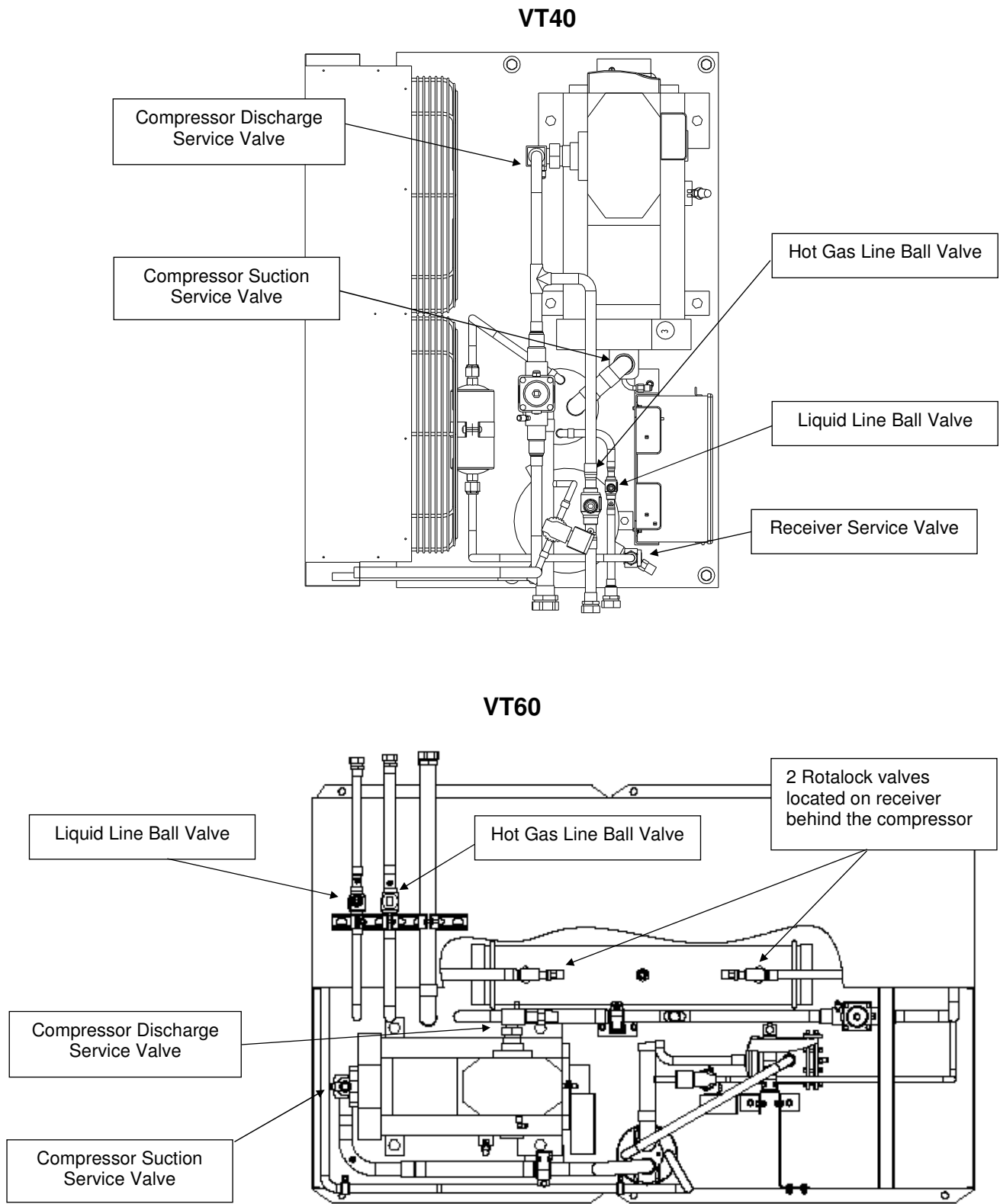
**FIGURE 4-1**  
**Evaporator Housing Covers (Upper & Lower)**



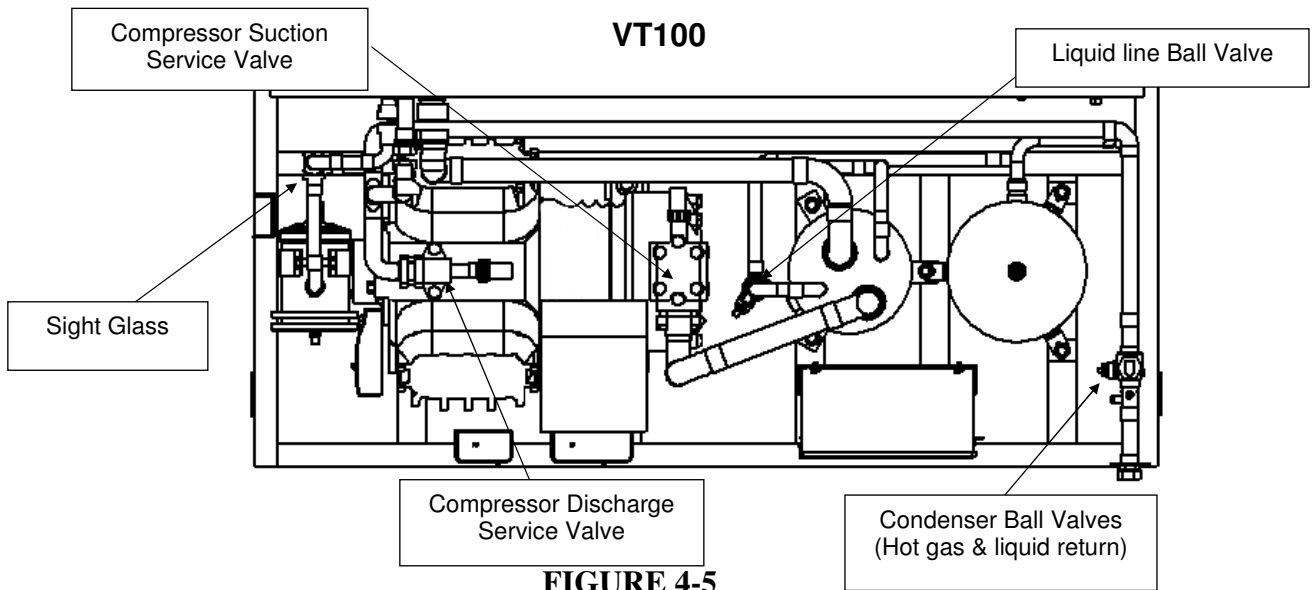
**FIGURE 4-2**  
**Circuit Breakers (200/230V machines)**



**FIGURE 4-3**  
**Lowside Control Panel Front**



**FIGURE 4-4**  
**Service and Ball Valve Locations**



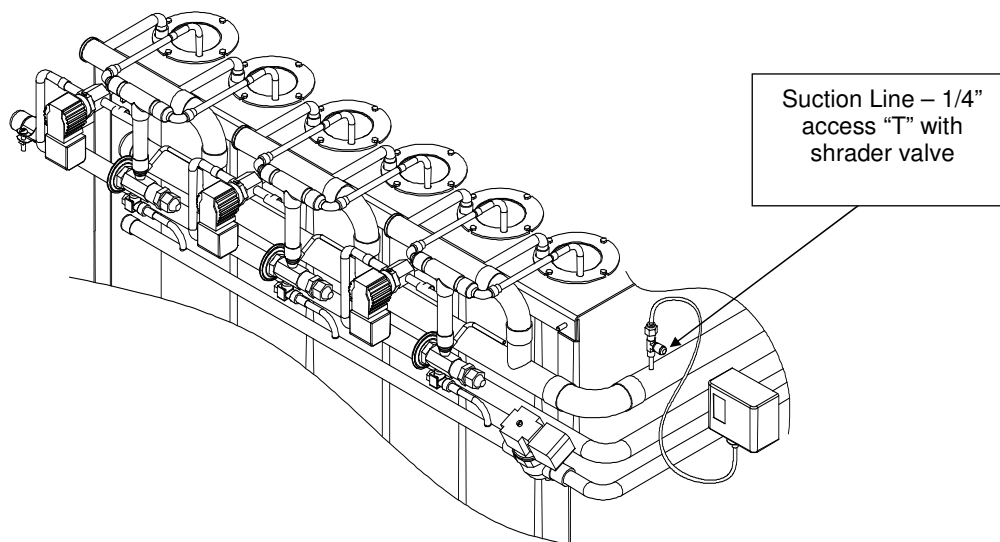
**FIGURE 4-5**  
**Service and Ball Valve Locations**

**Adding Refrigerant / System Charging:** To charge the system with cycling fans, observe sight glass during the ice making cycle. When the fans cycle off, the sight glass should clear in 8 to 10 seconds.

- If it takes longer than 10 seconds to clear the glass, the unit is undercharge. Add refrigerant to system at compressor suction port or the 1/4" access fitting on suction line. (See Figure 4-6)
- If the glass clears in less than 8 seconds, the unit is overcharged. Remove refrigerant from system following EPA standards.

**Note:** *Do not charge to a full sightglass. Do not charge in a harvest cycle.*

If packaged unit is totally out of refrigerant, add amount specified on machines nameplate.



**FIGURE 4-6**  
**Access port for adding refrigerant**

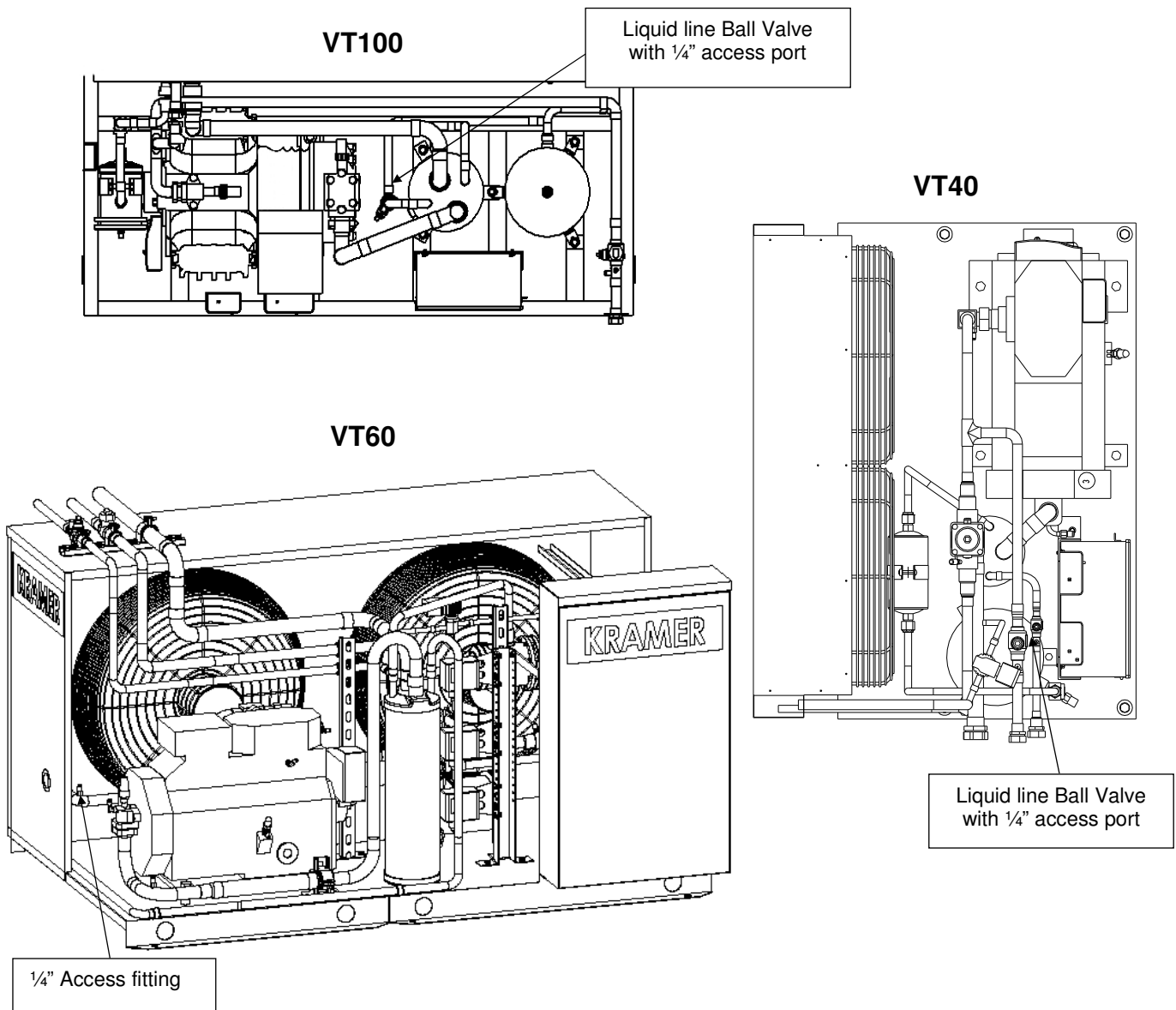
**Removing Refrigerant:** To remove refrigerant from an overcharged system, refrigerant gas may be removed from suction line 1/4" access port (See Figure 4-7). For quicker removal, liquid refrigerant may be reclaimed from the liquid line.

VT100 – access port on liquid line ball valve

VT60 – access fitting in line out of receiver

VT40 – access port in liquid line

**Note: Follow all EPA regulations and guidelines when handling refrigerant.**



**FIGURE 4-7**  
**Access Fitting for Removing Refrigerant**

**4-6**  
Initial Startup

**Blank**

## 5. Electrical Controls

### CONTROLS

**Explanation.** The VT-Series ice machine is controlled by a PLC (Programmable Logic Controller). The PLC controls the sequence of events and monitors the ice machine functions. The operational sequences of the VT-Series ice machine can be described best as a series of six different modes. Each mode identifies and defines a sequence of events that occur while in that mode and thereby cause it to move to the next mode. Only one mode is active at a time.

**Start-Up Mode.** The start-up mode is a function which prevents the premature automatic starting of the machine at the time of installation, after a power interruption, or after a machine fault. During Start-up, the machine will not start for two hours. This gives the crankcase heater time to boil any refrigerant out of the compressor. The start-up mode may be bypassed at any time by pressing the “Manual Harvest” (Start) button to immediately advance to the standby mode.

**NOTE:** While the machine is in the Start-Up Mode, the Fault Indicator light will remain “on” (will not be blinking).

**! CAUTION !**

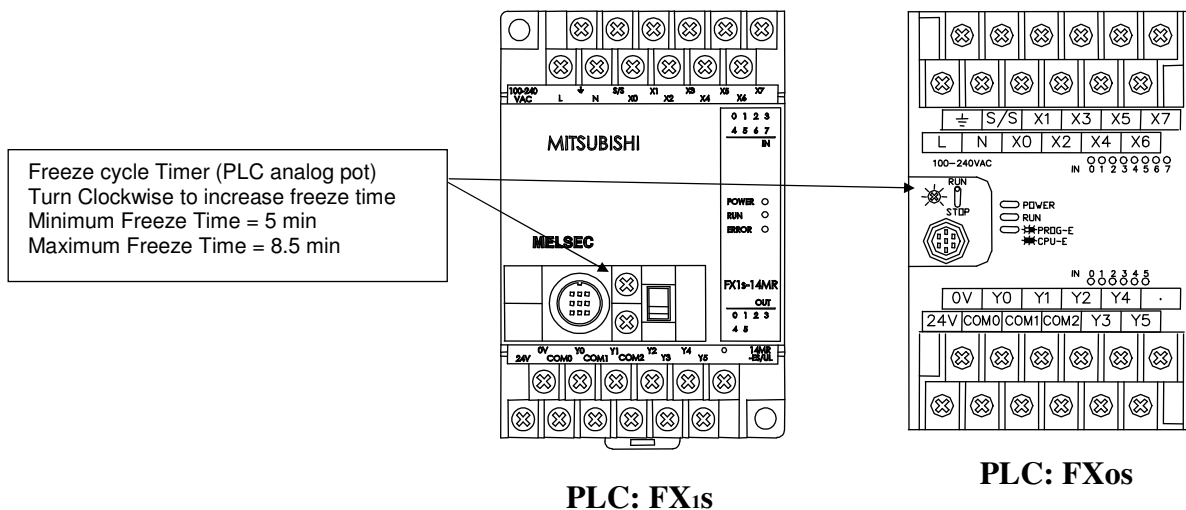
**If the power has been turned off to the machine, make sure the compressor crankcase is warm and there is no liquid refrigerant in with the oil before restarting the unit.**

**! CAUTION !**

**Standby Mode.** The standby mode is a decision making mode. It monitors the position of all the various switches in the control circuit and at the proper time decides which mode to advance to next.

Note: R404A machines are pumped down while in the Standby mode. If the pressure comes back up after 3 minutes, (the low pressure switch “closes”), the machine will go to the Pumpdown Mode.

**Freeze Mode (Freeze Cycle).** The freeze mode is active during the normal ice making cycle. During this time, liquid feed valve is energized (R404A machines only) and the circulating water pump and compressor are running. The freeze time is determined by the PLC analog timer (0-3.5 min) plus 5 minutes. (Minimum freeze cycle time = 5 minutes, maximum freeze cycle time = 8.5 minutes)



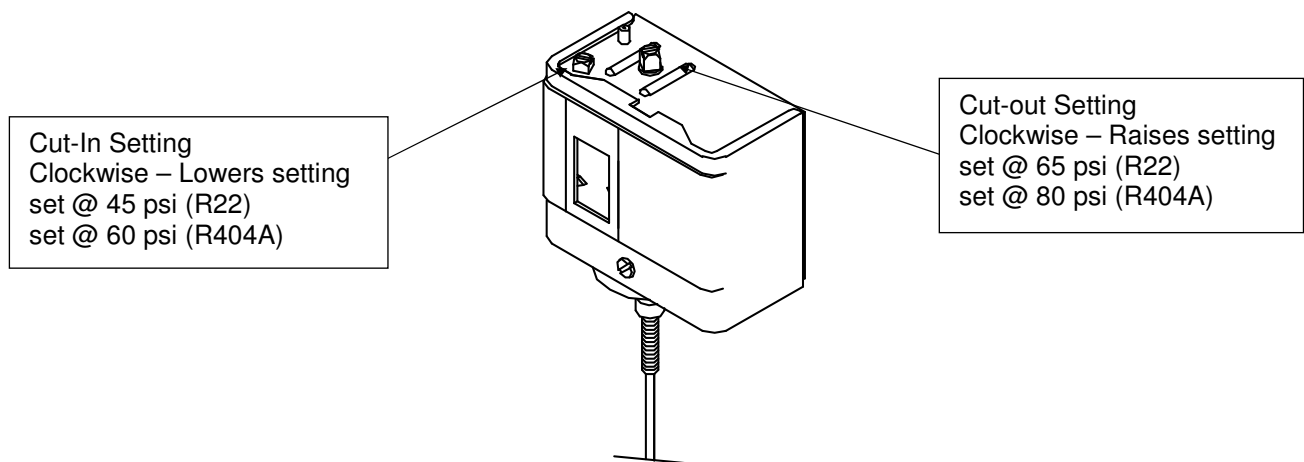
**FIGURE 5-1**  
**PLC – Programmable Logic Controllers**

## Electrical Controls

**Harvest Mode (Thaw Cycle).** The harvest mode is normally initiated at the termination of the freeze mode. At this time, the circulating water pump stops and the liquid feed valve closes (R404A machines only). After five seconds, the “D” (thaw gas) solenoid valves open and the chopper motor starts. On split VT40’s & VT60’s, the hot gas loop valve energizes and on VT100’s, the suction stop valve energizes when the chopper starts and thaw gas valves open. When the suction pressure reaches the set point on the Harvest Hold (HH) pressure switch (PLC input #2 light will turn “off”), the harvest timer will begin to time. The harvest timer is an internal timer in the PLC set for 45 seconds.

The harvest mode is terminated by the PLC thaw (harvest) timer at which time the machine will begin another freeze cycle. The harvest mode can also be terminated manually by pushing in the “Manual Harvest (Start)” button.

Increasing Harvest Time – To increase the harvest cycle time, raise the HH pressure switch cut-out setting. (See Figure 5-2) This will increase the time it takes for the suction pressure to reach the set-point on the switch, thereby increasing the harvest time.



**FIGURE 5-2**  
**Harvest Hold Pressure Switch**  
(located on top of lowside control panel)

Long Harvest Cycle Safety – The PLC monitors harvest cycle time. If the suction pressure does not reach the HH pressure switch set-point within **3 minutes**, the machine will shut down and go to the Fault Mode.

**NOTE:** If the “Selector Switch” switch is in the “Off” position or the bin control is satisfied the machine will complete the Freeze, Harvest and Pumpdown cycle before shutting off (standby mode). Machines with R22 do not go through a pumpdown cycle before shutting off.

**Pumpdown Mode (R404A machines only).** All R404A machines have a liquid feed solenoid valve and go through a Pumpdown cycle before shutting off. During the Pumpdown cycle the water pump and compressor are “on” and the liquid feed solenoid valve is “closed”. The machine will run in the Pumpdown mode until the Low pressure safety switch “opens”. After shutting off on low pressure, the machine will go to the Standby mode.

Note: If the suction pressure does not reach the cut-out point on the low pressure switch within 2 minutes, the machine will fault out on a “Pumpdown Fault”.

**Continuous Pumpdown (R404A machines only).** While in the Standby mode, the machine will remain pumped down. After a 3 minute delay, if the pressure comes up in the freezer and the low pressure safety switch “closes” (pressure gets above 20 psig), the compressor will come “on” and pump the machine down.

**Clean Mode.** The “Clean” mode is considered to be a maintenance or service function of the machine. During this mode only the water pump will run.

The water pump can be stopped by simply moving the “Selector Switch” from the “Clean” to the “Off” position. To restart the water pump, move the “Selector Switch” back to the “Clean” position and press the “Manual Harvest (Start)” button. Ice machine cleaning solution can be circulated through the tubes to accomplish the cleaning procedure. If the water pump is left to run in the clean mode for more than two hours, the PLC will shut the machine off. The clean mode can be resumed by pushing the “Manual Harvest” button.

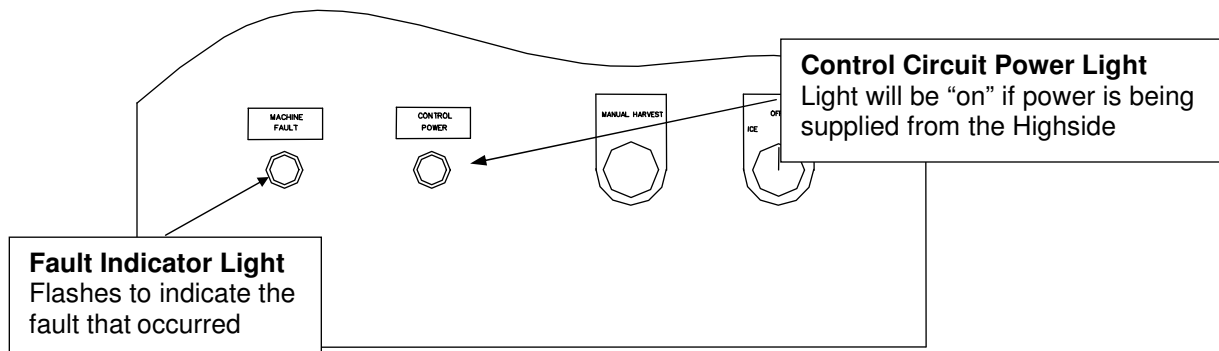
**NOTE:** Running in Clean mode for extended period of time can cause excessive pressure to build up in the freezer.

At the termination of the clean mode, the machine can be returned to ice making mode by putting the “Selector Switch” in the “Ice” position and pressing the “Manual Harvest” button.

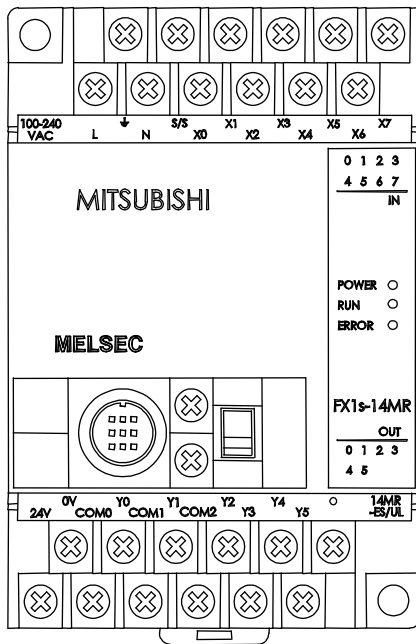
**Fault Mode.** The VT Series is equipped with a PLC (programmable logic controller) that controls all aspects of the operation. One of the functions of the PLC is to shut down the machine when a problem arises and send a signal to the fault indicator light located on the front of the electrical panel. (Figure 5-3) The red light will blink 1 to 6 times when a problem has caused the machine to shut down. See table below for the description of the fault modes.

#	Description	Switch Reset (Auto or Manual)
1	Low Suction Pressure	Auto
2	High Discharge Pressure	Manual
3	Low Oil Pressure	Manual
4	Long Harvest Cycle	N/A
5	Cutter Motor	Auto
6	Pumpdown Fault	N/A
Solid	Power Failure	N/A

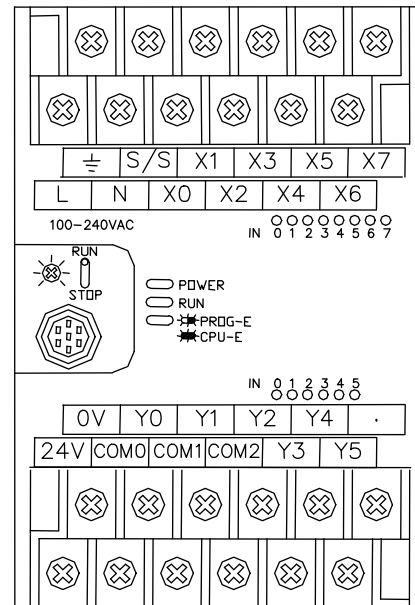
**TABLE 5-1**  
**PLC Fault Codes**



**FIGURE 5-3**  
**Lowside Control Panel Front**



PLC: FX1s



PLC: FX0s

**PLC Inputs**

#	Description
0	Current Sensing Relay (CSR) for cutter motor
1	"On" Switch & Bin control (in series)
2	Harvest Hold (HH) Pressure Switch
3	Start / Manual Harvest Switch
4	"Clean" Switch
5	High Pressure safety ("off" when tripped)
6	Low Pressure safety ("off" when tripped)
7	Oil Safety / Compressor OL (VT100)

**PLC Outputs**

#	Description
0	Machine Fault Indicator Light
1	Liquid Feed Solenoid (R404A machine only)
2	Compressor
3	N/A
4	Water Pump
5	Cutter / "D" valve / Defrost loop valve or Suction Stop valve (VT100)

**FIGURE 5-4  
PLC Inputs & Outputs**



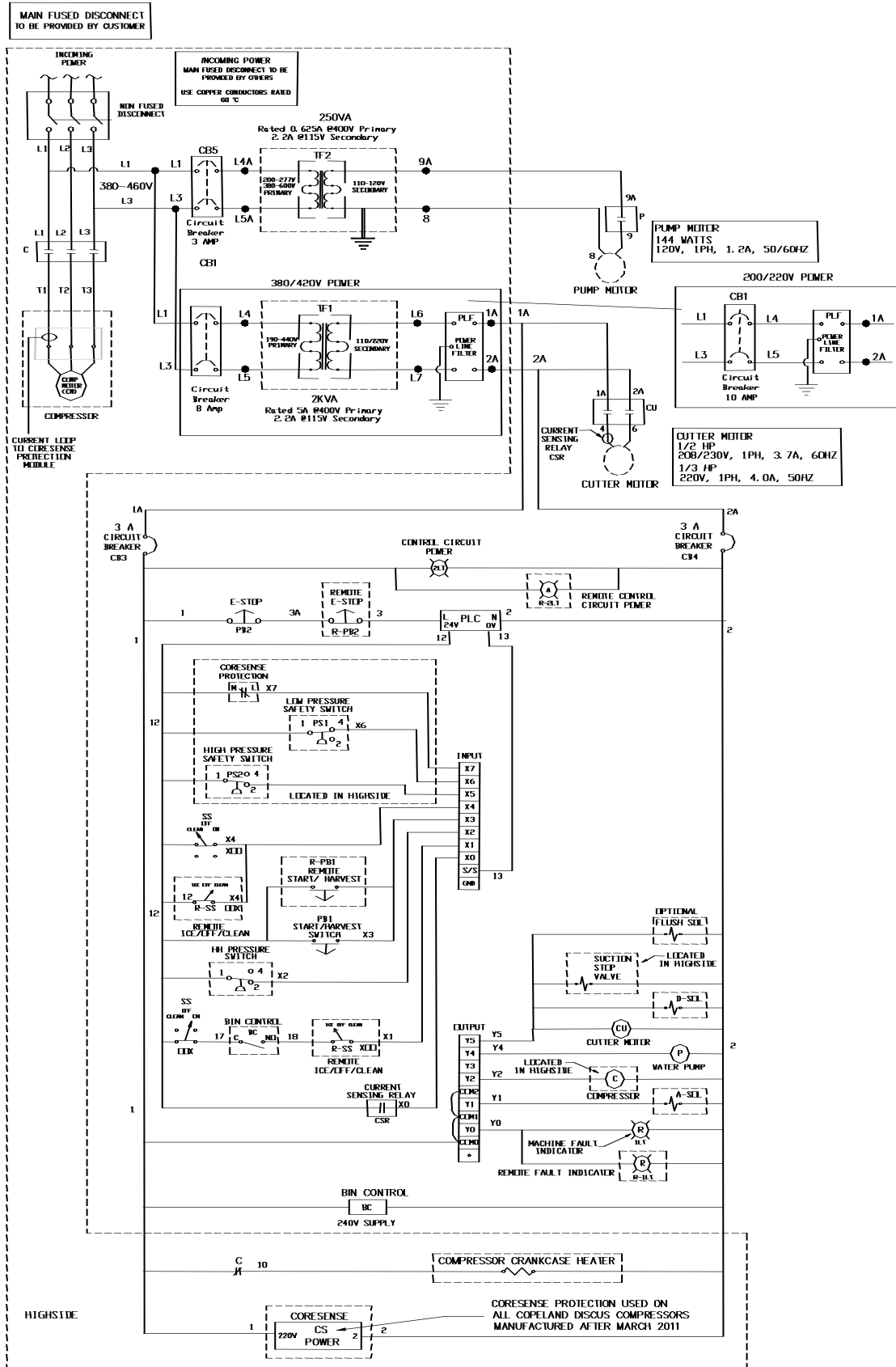
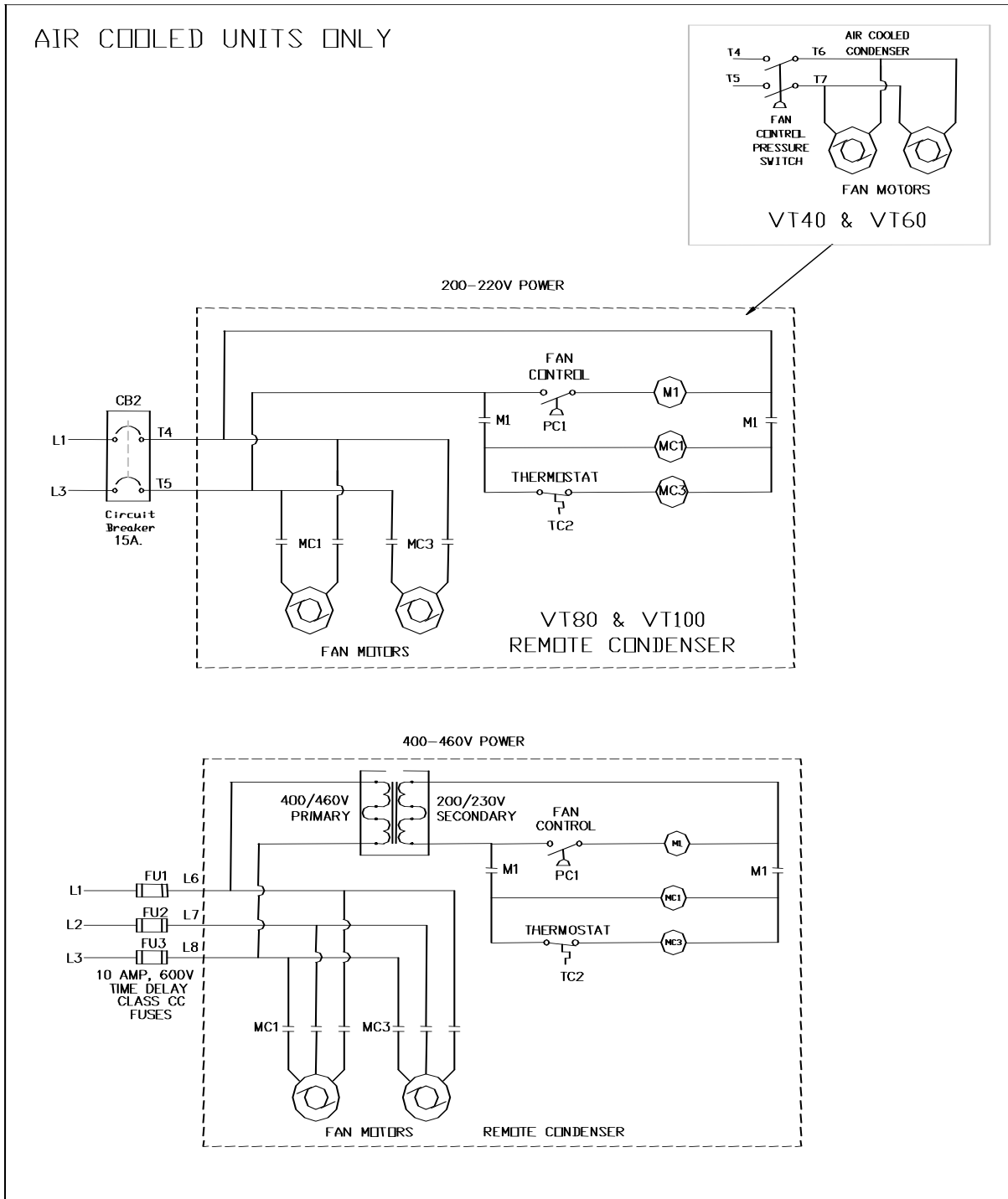
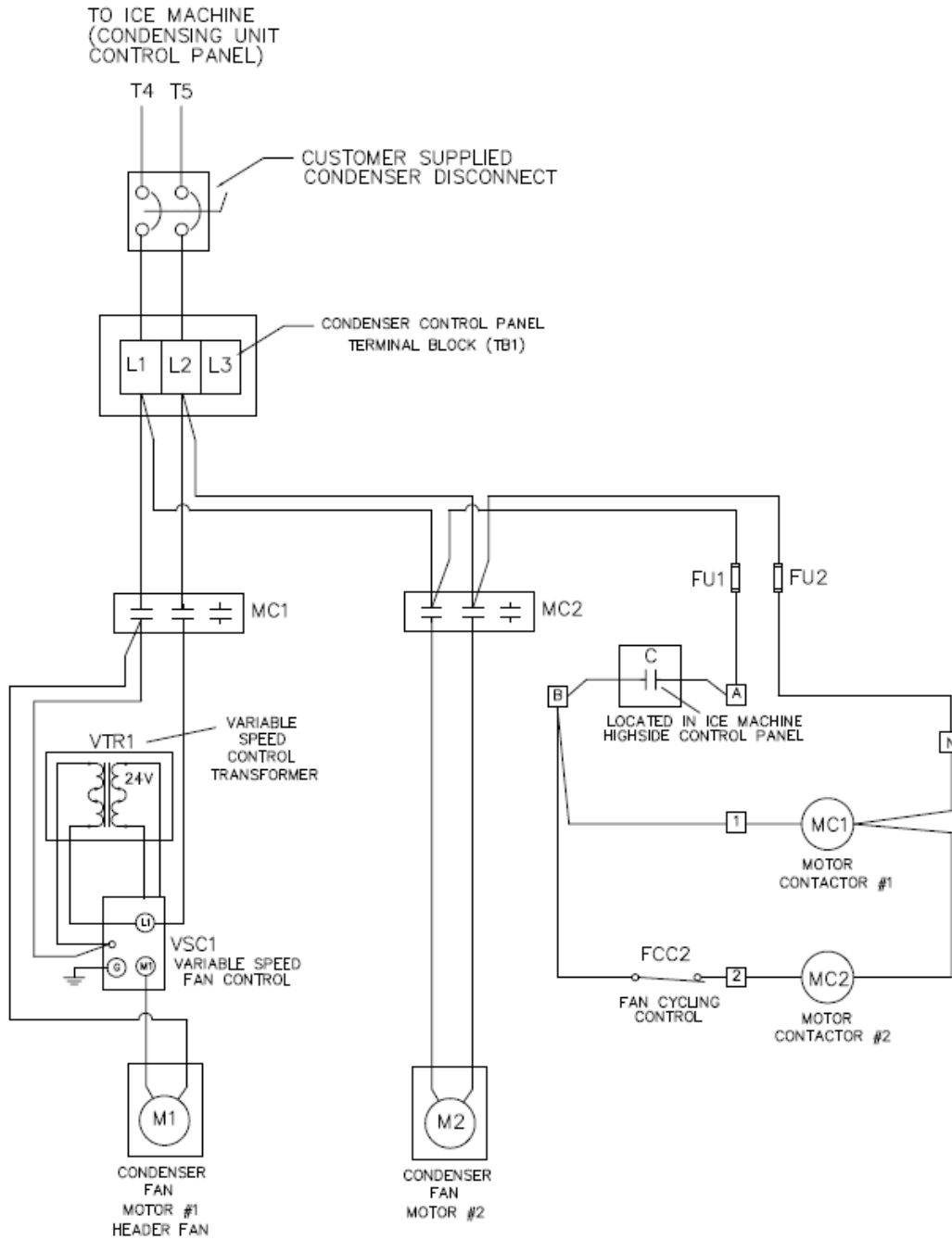


FIGURE 5-5A

CE Rated VT100 Electrical Schematic – 200-220V / 400-440V (Water Cooled)



208/230V Condenser



**FIGURE 5-6B**  
**KeepRite Air Cooled Condenser Wiring (200-240V)**

**Note:** Fan cycling switch, FCC2 (Danfoss) for fan motor #2, is not factory set. Switch must be set in the field before startup. Cut Out = 210 psi, Diff = 25 psi. Use an accurate gage to set, not the scale on the pressure switch.

400/460V Condenser

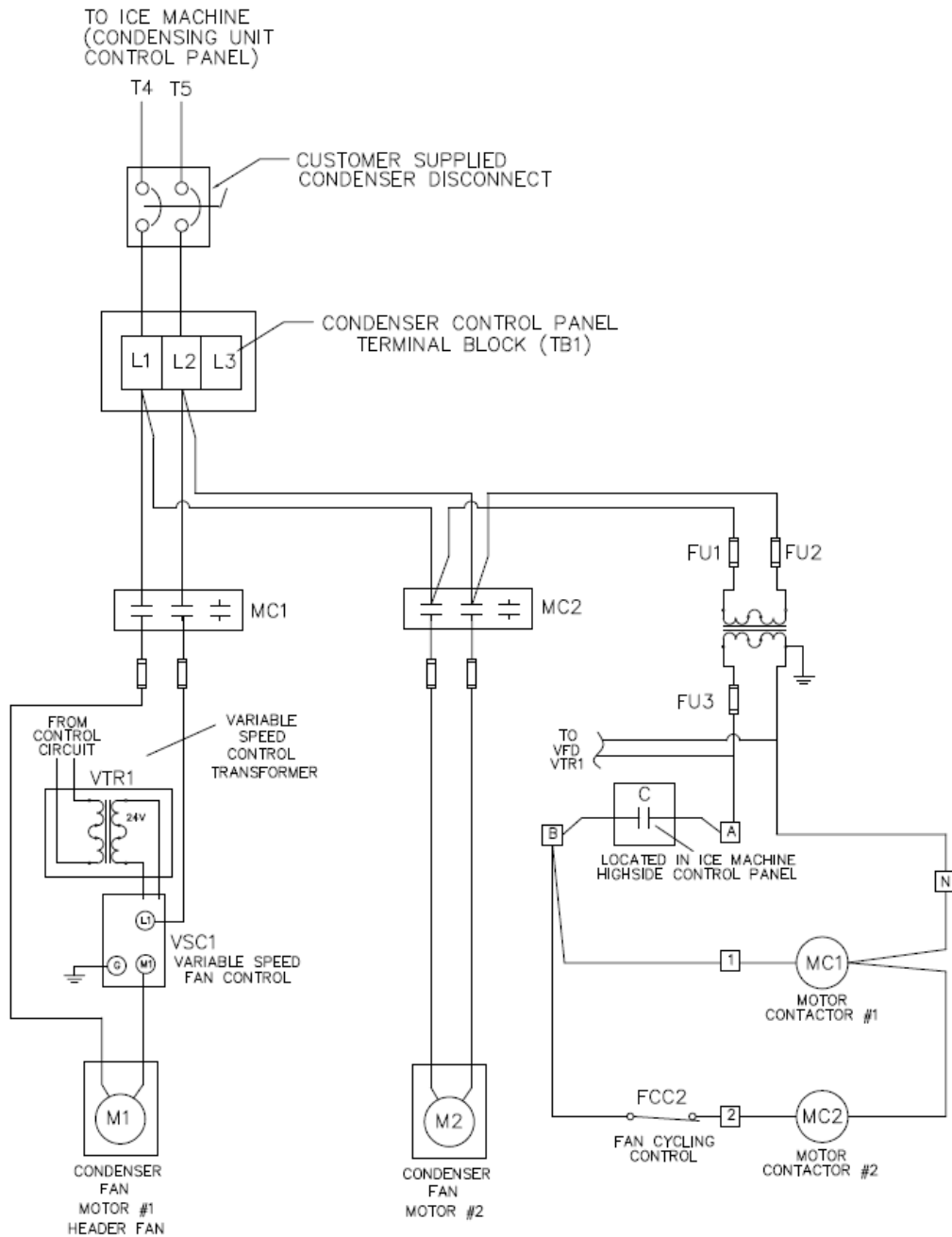
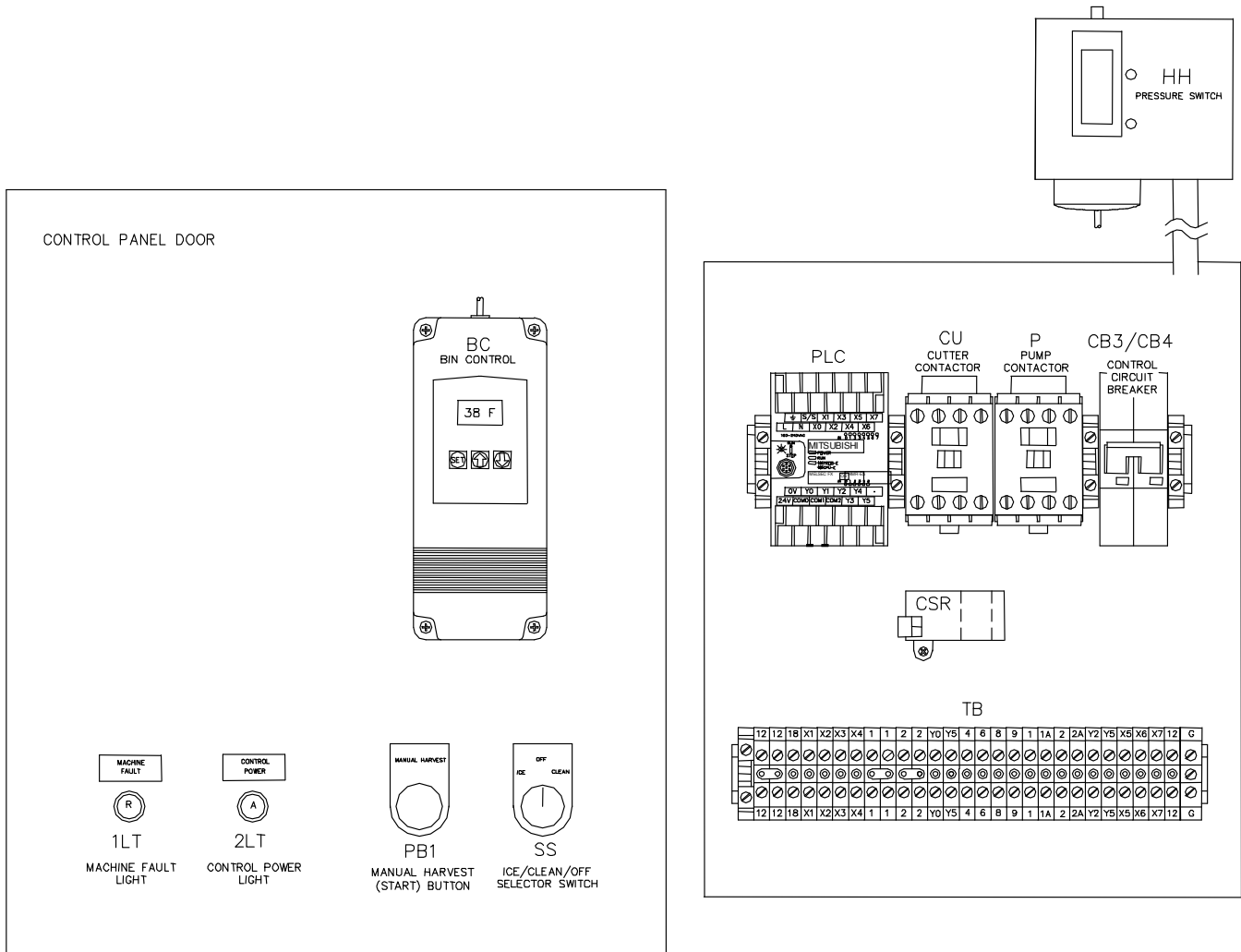


FIGURE 5-6C  
KeepRite Air Cooled Condenser Wiring (400-460V)

**Note:** Fan cycling switch, FCC2 (Danfoss) for fan motor #2, is not factory set. Switch must be set in the field before startup. Cut Out = 210 psi, Diff = 25 psi. Use an accurate gage to set, not the scale on the pressure switch.

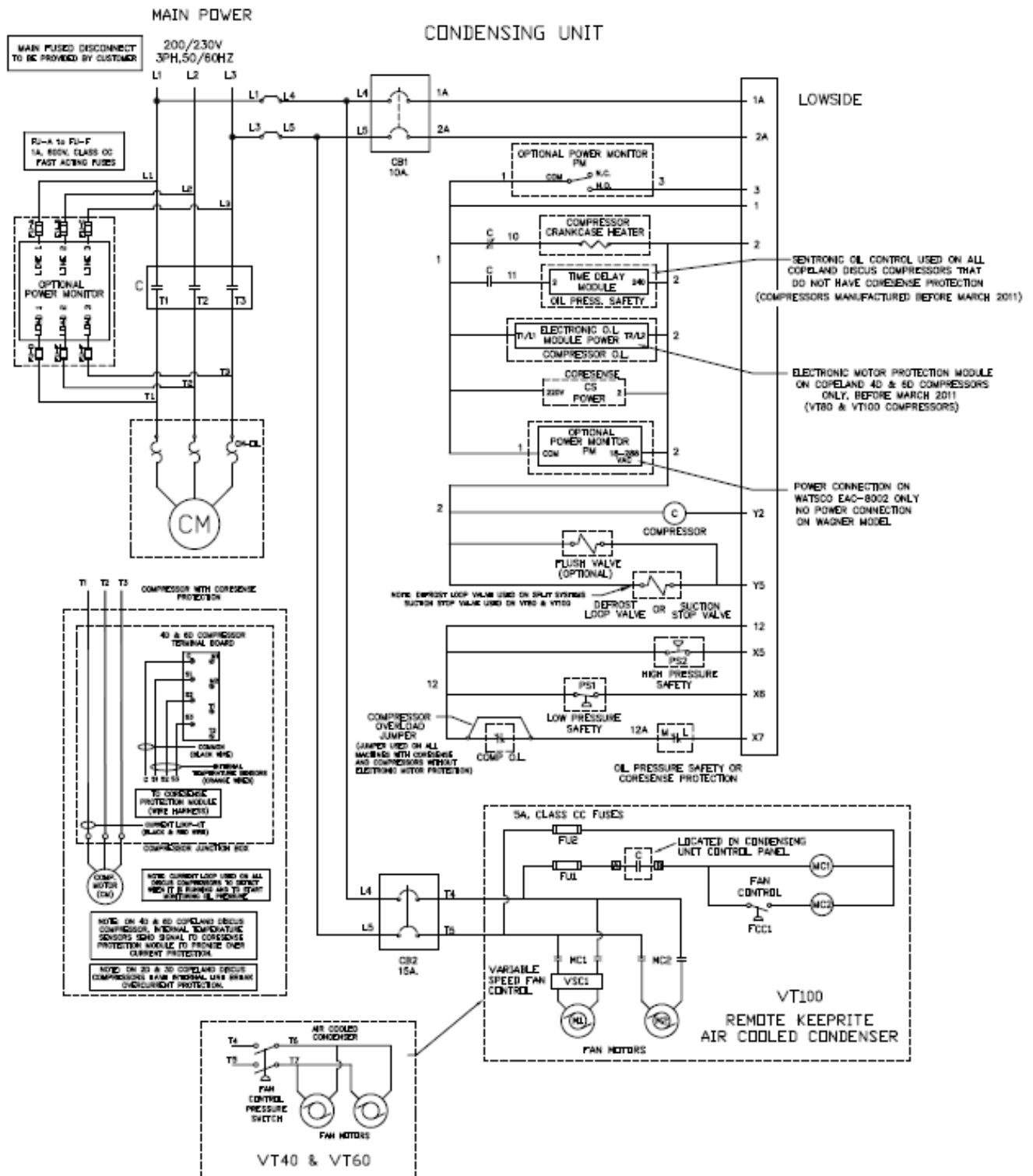
# 5-10 Electrical Controls

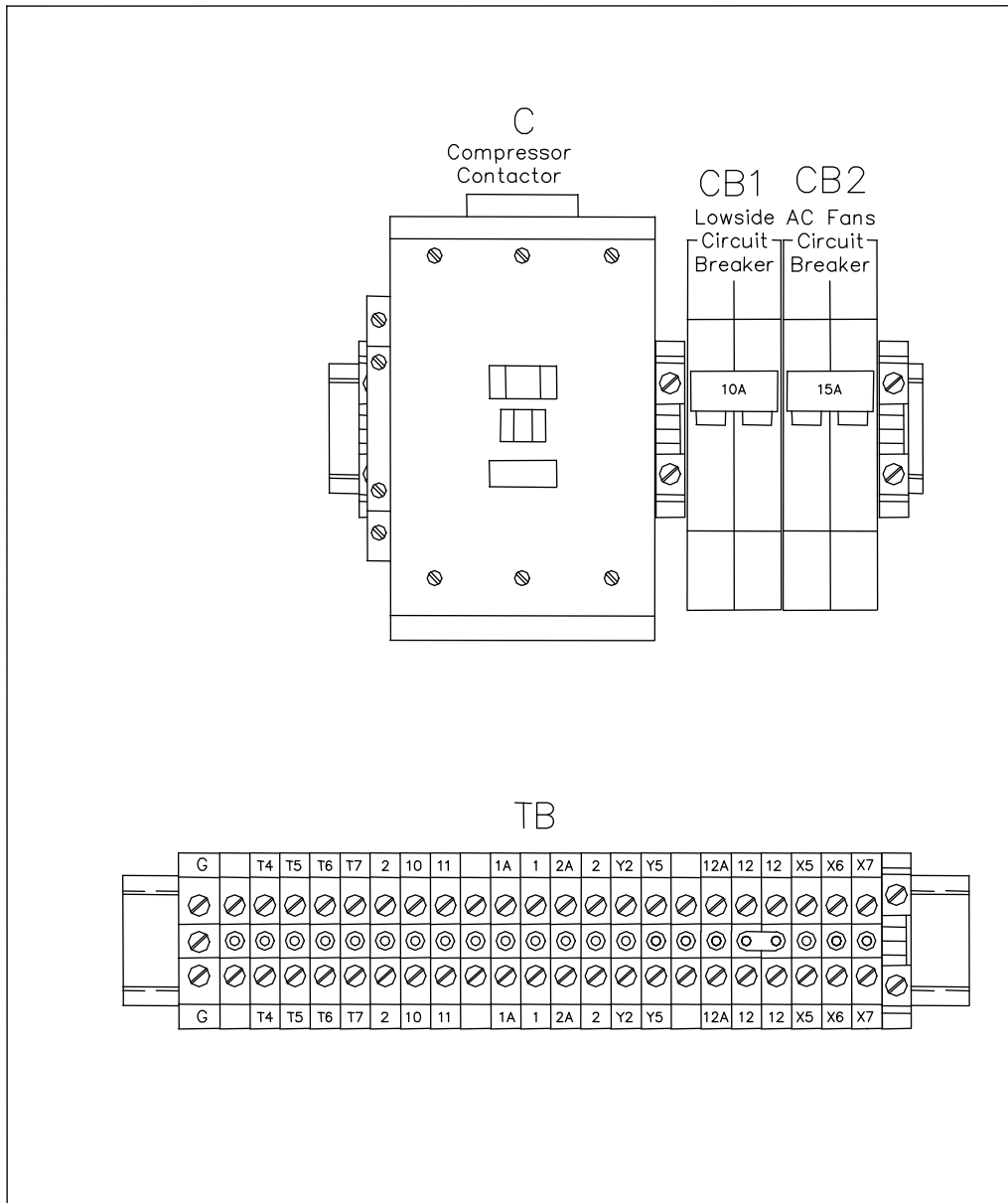


## Lowside Control Panel Parts

BC	<a href="#">12A2117G09</a>	Ice Bin Control
CB3/CB4	<a href="#">12A7515E21</a>	Control Circuit Breaker – 2 pole (3 Amp)
CSR	<a href="#">12A7537S07</a>	Current Sensing Relay (cutter/chopper motor)
CU	<a href="#">12A7516E23</a>	Cutter Motor Contactor
E-STOP	<a href="#">12A7500E75</a>	Contact Block/Mounting Latch, 1NC (CE Machine only)
	<a href="#">12A7500E130</a>	Push Button, Push-Pull
P	<a href="#">12A7516E23</a>	Pump Motor Contactor
PB1	<a href="#">12A7500E56</a>	Manual Harvest (Start) Button
	<a href="#">12A7500E75</a>	Contact Block, 1 N.O. (for Manual Harvest Button)
PLC	<a href="#">12A7536M01</a>	Programmable Logic Controller
HH	<a href="#">12A2117B03</a>	Harvest Hold Pressure Switch – Open on Rise
SS	<a href="#">12A7500E61</a>	3 Position Selector Switch
	<a href="#">12A7500E73</a>	Contact Block, 2 N.O. (for Selector Switch)
TB	N/A	Terminal Block
1LT	<a href="#">12A7520E33</a>	Machine Fault Indicator Light, 250V, Red
2LT	<a href="#">12A7520E34</a>	Control Power Indicator Light, 250V, Amber

**FIGURE 5-7  
Lowside Control Panel Layout**





**Condensing Unit Control Panel Parts**

C	<a href="#">12A7516E29</a>	VT40 Compressor Contactor, 43Amp
	<a href="#">12A7516E30</a>	VT60/80/100 Compressor Contactor, 72Amp
	<a href="#">12A7518E30</a>	Auxiliary Contact, 1 N.O./1 N.C.
CB1	<a href="#">12A7515E18</a>	Lowside Circuit Breaker, 2 pole (10Amp)
CB2	<a href="#">12A7515E19</a>	AC Fan motors Circuit Breaker, 2 pole (15Amp)
TB	N/A	Terminal Block

**FIGURE 5-8A**  
**Standard 208-240V Condensing Unit Control Panel (Air Cooled)**

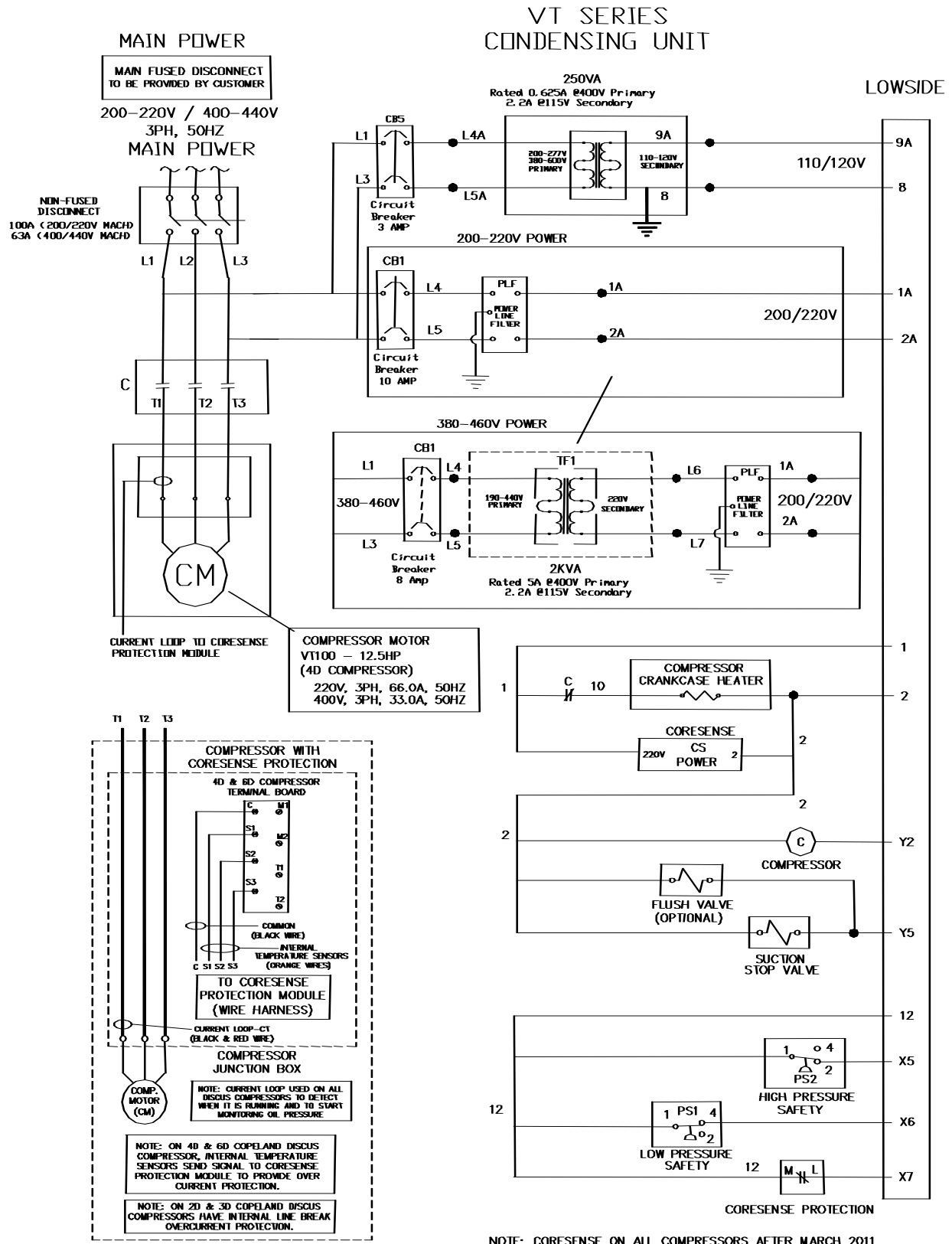
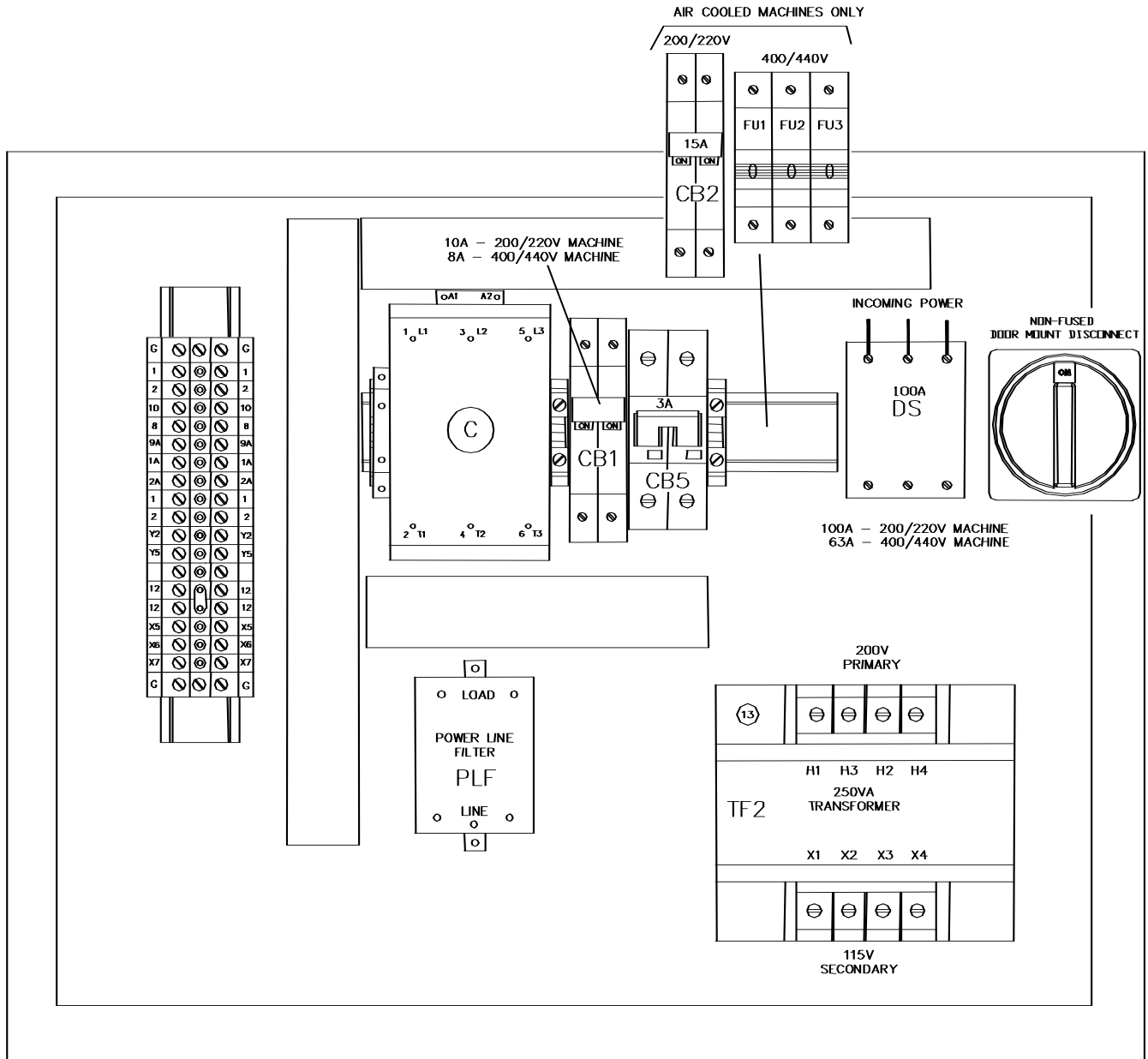


FIGURE 5-9

CE Rated VT100, 200-220V/400-440V Condensing Schematic (Water Cooled)



	PART #	DESCRIPTION	QTY
C	12A7516E29	CONTACTOR, 3 POLE, 43A	1
	12A7516E30	CONTACTOR, 3 POLE, 72A	
	12A7518E30	AUX CONTACT, 1 NO/1 NC	1
CB1	12A7515E18	CIRCUIT BREAKER, 10A, 2 POLE, (200/220V MACH)	1
	12A7515E35	CIRCUIT BREAKER, 8A, 2 POLE, (400/440V MACH)	
CB2	12A7515E19	CIRCUIT BREAKER, 10A, 2 POLE, (AC, 200/220V MACH)	1

	PART #	DESCRIPTION	QTY
CB5	12A7515E21	CIRCUIT BREAKER, 2 POLE	1
* DS	12A2790H07	DISCONNECT HANDLE	1
	12A2790D07	DISCONNECT, 63A, DOOR MNT (400/440V MACH)	1
	12A2790D11	DISCONNECT, 100A, DOOR MNT (200/220V MACH)	
FU1- FU3	12A7504E12	FUSE, 10A, 600V, TD, CLASS CC (AC, 400/440V ONLY)	3
* PLF	12A7527S06	POWER LINE FILTER, 10A	1
* TF2	12A7519E38CE	TRANS, 250VA, 200/400VAC PRI, 120VAC SEC	1

\* NOTE: CE UNITS ONLY

FIGURE 5-9A  
CE Rated VT100, 200-220V/400-440V Condensing Unit Control Panel (Water Cooled)

## 6. Maintenance

### Preventive Maintenance

#### For The Manager Who Depends Upon This Machine For Efficient Operation.

“Preventive Maintenance” simply means that you or a delegated employee makes a daily visual check of your Vogt Ice machine. Here is what to look for and why:

#### Daily checklist:

1. Is the machine running or is the bin full
2. Bin doors kept closed
3. Thermostat sensor in bracket
4. Does all ice discharge during harvest
5. Cleanliness
6. Unusual noises

**Why?** When you make these simple observations on a daily basis, you insure the smooth production of ice for your facility. When you are aware of the proper operating conditions and observe them on a daily basis, changes in these conditions can alert you to changes in the operation of the machine which may require maintenance--long before a service situation arises.

#### **Note To Manager or Owner:**

The following page is a complete Preventative Maintenance Schedule that should be performed each 90 days. The Preventative Maintenance page may be copied and given to your service person. It should be signed, dated, and returned to you for permanent record.

**Preventive Maintenance Program**

Model # \_\_\_\_\_ Serial # \_\_\_\_\_ Date \_\_\_\_\_

Customer/Address \_\_\_\_\_

Mgr. Name \_\_\_\_\_ Service Tech Name \_\_\_\_\_

The following service performed and checked:

- Last maintenance performed (approx. date) \_\_\_/\_\_\_/\_\_\_
- Scale condition of water tank & tubes (good - fair - poor)
- All drains freely draining (water tank, drip pan, ice bin)
- Ice machine cleaner circulated through system
- AC condenser clean (if applicable)
- Voltage at machine (actual reading) L1-L2 \_\_\_\_\_, L2-L3 \_\_\_\_\_, L1-L3 \_\_\_\_\_
- Compressor amps (halfway through the freeze cycle) L1 \_\_\_\_\_ L2 \_\_\_\_\_ L3 \_\_\_\_\_
- Cutter motor amps (cutting ice) \_\_\_\_\_
- Water pump amps \_\_\_\_\_
- AC condenser motor amps (if applicable) \_\_\_\_\_
- Crankcase heater heating
- Refrigerant charge (okay - high - low)
- Leak checked system \_\_\_\_\_ leaks found & repaired
- Compressor oil level (i.e, 1/4 - 1/2 - 3/4 - low - high)
- PSIG, low pressure switch set @ 10 psi
- PSIG, high pressure switch set @ 300 psi (R22) / 350 psi (R404A)
- Bin stat(s) installed and operate properly
- Make-up water float valve adjusted okay

\_\_\_\_\_ Suction PSIG at end of freeze

\_\_\_\_\_ Suction PSIG during harvest (high/low)

\_\_\_\_\_ PSIG, Discharge pressure regulator (Water cooled only)

\_\_\_\_\_ Discharge PSIG at end of freeze

\_\_\_\_\_ °F/°C at machine

\_\_\_\_\_ °F/°C outside ambient (at condenser if applicable)

\_\_\_\_\_ °F/°C make-up water temperature

\_\_\_\_\_ Freeze cycle time (minutes)

\_\_\_\_\_ Harvest cycle time (minutes)

\_\_\_\_\_ First ice out (seconds)

\_\_\_\_\_ All ice out (seconds)

\_\_\_\_\_ Pounds of ice per cycle

Capacity check: ice # per cycle X (1440 / total cycle time (min)) = lbs./24 hrs.

Remarks: \_\_\_\_\_  
\_\_\_\_\_  
\_\_\_\_\_

**Air-Cooled Condenser Cleaning.** Visual inspection will indicate if dirt is accumulating and clogging the fin face of the condenser. A vacuum cleaner, compressed air, or a brush may be used to remove any accumulation of loose dirt from the fin section of the condenser.

For the removal of more severe accumulations of dirt or foreign materials, a detergent-type cleaner can be used. This cleaning agent can be supplied by your local refrigeration supply house. Follow the manufacturer's instructions when using a liquid cleaner.

If fins have been damaged, they should be straightened with the proper fin comb.

**Compressor Oil.** In starting and charging the unit, the oil sight glass in the crankcase of the compressor should be watched carefully for the first hour to make certain the proper lubrication is being maintained. The oil may become low in the crankcase on an initial start-up if the electrical current has been interrupted to the machine, thus de-energizing the compressor crankcase heater.

Before starting the machine again, the heater should be energized for a time period of at least two hours to evaporate refrigerant that may have condensed in the crankcase during the shutdown period. If the oil level is low after start-up, it should begin to return after a short period of operation.

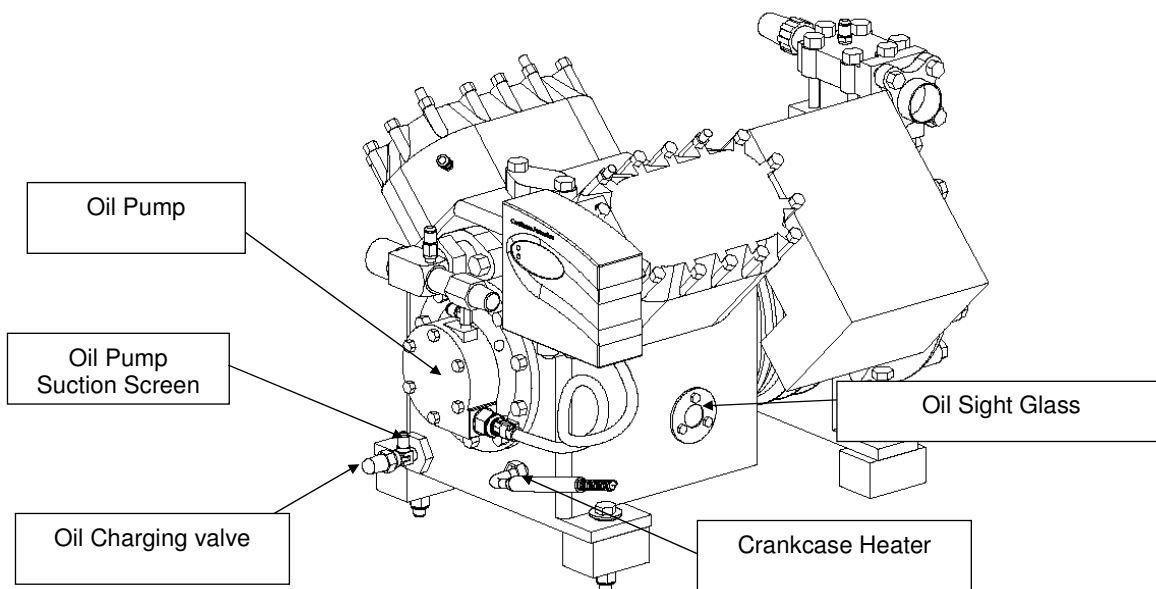
The oil level should be checked frequently, particularly during the start-up operation, to see that a sufficient amount of oil remains in the crankcase. While it is important to observe the oil splash during operation, the true level can be obtained only when the compressor is stopped. With the compressor idle, the oil level should be between 1/2 to 3/4 of the sight glass, but not above the top of the sightglass.

Although the machine was shipped with the oil charge, which was originally added for the test operation, it may be necessary to add some oil when or if new refrigerant is added to the system.

An oil pump should be used to force any oil that may be required into the system. Oil may be added to the compressor of all units through the compressor oil charging port. Air should be purged from the oil pump discharge line by forcing some oil through the line before tightening the charging port.

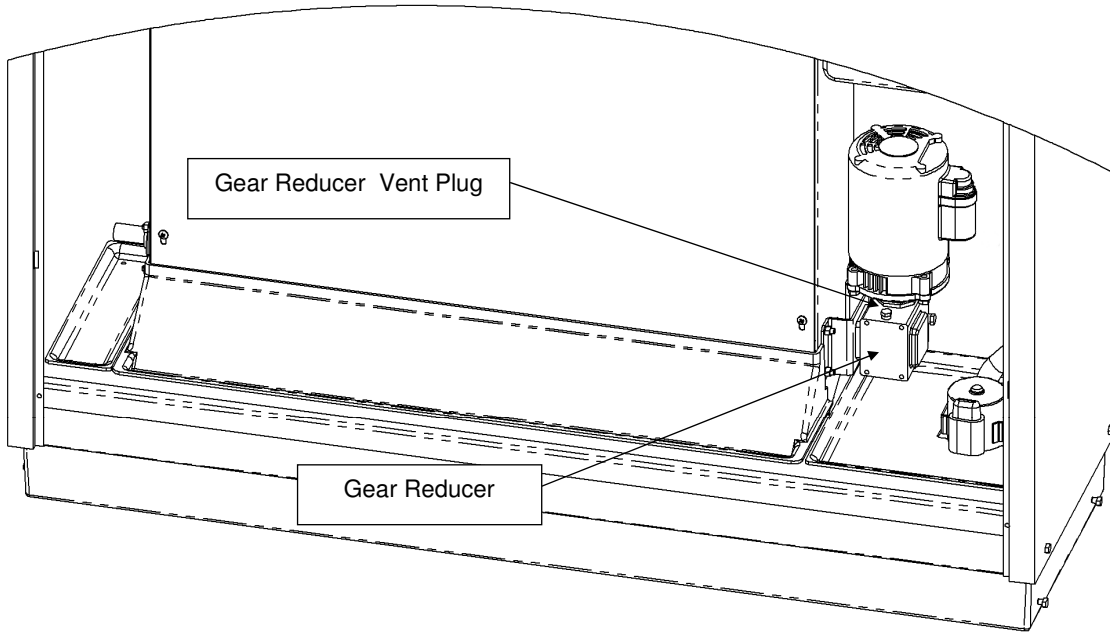
R22 - Dual Inhibited Suniso 3GS (Viscosity 150) or equal.

R404A - Ultra 32 – 3MAF, Mobil EAL Arctic 22 CC or equal. See page 3-1 for amount.



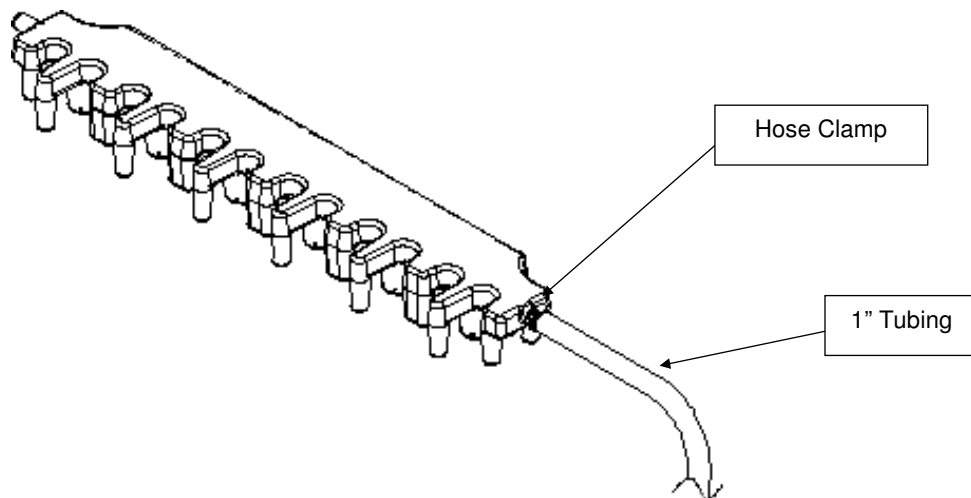
**FIGURE 6-1**  
**Copeland Discus Compressor (VT100)**

**Chopper Gear Reducer Oil.** The oil level for the gear reducer should be checked if there is evidence of a leak. It should be level with the plugged opening in the side of the gear housing. Use Mobile 600W cylinder oil or equal.



**FIGURE 6-2**  
**Gear Reducer**

**Water Distributor.** At times it may be necessary to clean the plastic water distributor. Remove the water supply tube by removing the hose clamp. The water distributor may be soaked in ice machine cleaner. Make sure all holes are free of dirt and calcium buildup.

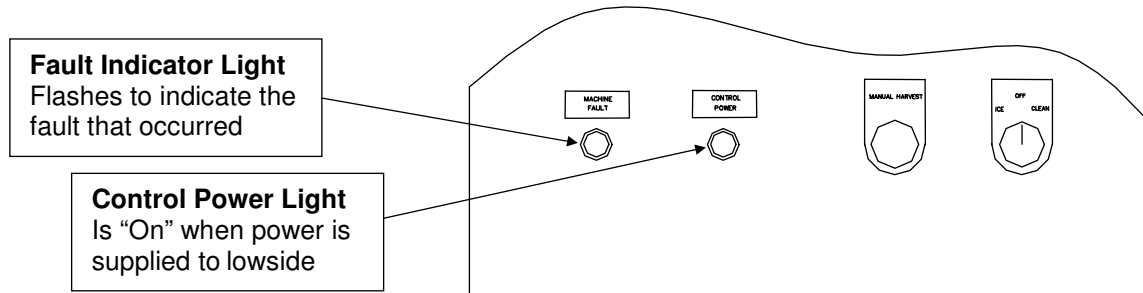


**FIGURE 6-3**  
**Water Distributor**

## 7. Troubleshooting

The VT Series ice machine is equipped with a PLC (programmable logic controller) that controls all aspects of the machines operation. One function of the PLC is to shut down the machine when a machine fault occurs. By continuously monitoring the High and Low pressure safety switches, the harvest cycle time, and the oil pressure, the PLC can determine if a problem exists.

**Machine Fault Light** - if the machine shuts off due to a high pressure fault, low pressure fault, a "long harvest cycle" fault or an oil pressure fault, the machine will not automatically restart. When a "fault" occurs, the PLC sends a signal to the fault indicator light located on the control panel door.

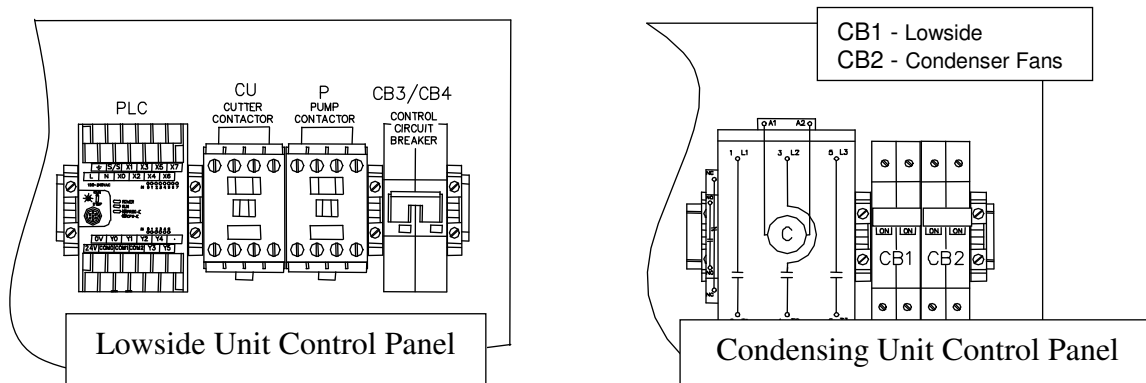


**FIGURE 7-1**  
**Lowside Control Panel Front**

#	Description	Switch Reset (Auto or Manual)
1	Low Suction Pressure	Auto
2	High Discharge Pressure	Manual
3	Low Oil Pressure	Manual
4	Long Harvest Cycle	N/A
5	Chopper Motor Fault	N/A
6	Pumpdown Fault	N/A
Solid	Power Failure	N/A

**TABLE 7-1**  
**PLC Fault Codes**

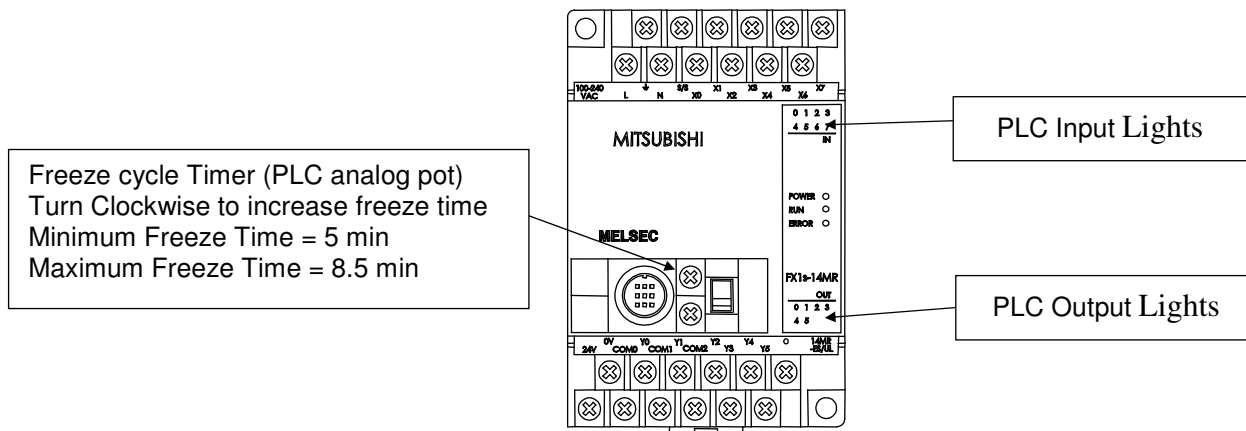
**Control Power Light** – if the machine is shut off and the “Control Power” light on the lowside unit is not “On”, check the 3A circuit breaker (CB3/CB4) in the lowside control panel. If after resetting the breaker, the control light still does not come on, check the 10A breaker (CB1) in the condensing unit control panel.



**FIGURE 7-2**  
**Control Panel**

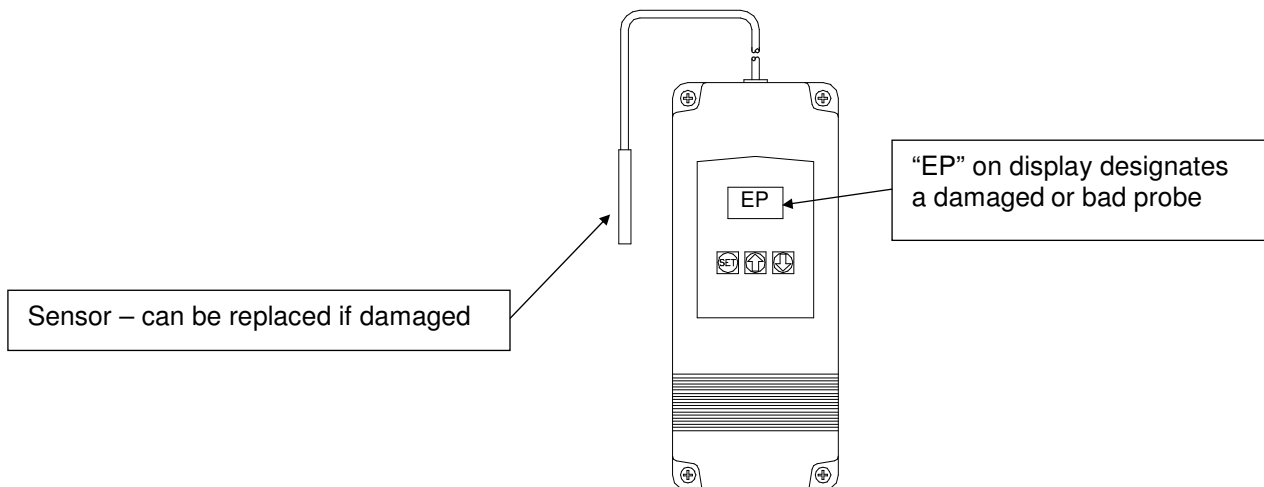
		#	Description			#	Description
Inputs	0	Current Sensing Relay (chopper)	Outputs	0	Fault Indicator light		
	1	"On" Selector Switch/Bin Control		1	Liquid Feed Solenoid (R404A machines only)		
	2	HH Pressure Switch		2	Compressor		
	3	Manual Harvest (Start) Button		3	N/A		
	4	Clean Switch		4	Water Pump		
	5	High Pressure Safety Switch		5	Chopper/Hot Gas Valve/Defrost Loop or Suction Stop valve (VT100)		
	6	Low Pressure Safety Switch					
	7	Oil Safety / Compressor OL (VT100)					

**TABLE 7-2**  
**PLC Inputs/Outputs**



**FIGURE 7-3**  
**PLC (FX1S)**

**Damaged Bin Control Sensor** – If the machine is not running and it uses the electronic temperature control to shut the machine off when the bin is full, one of the first things to check is the Bin Control sensor. If the sensor is bad or has been damaged, “EP” will be displayed. See 8-3 for more details.



**FIGURE 7-3**  
**Electronic Bin Control**

## MACHINE INOPERATIVE

**No Electrical Power:** Check main electrical fused disconnect or circuit breaker. If power has been off, crankcase heater should be energized two (2) hours prior to starting.

**Note:** If no power to the lowside unit, check 10A breaker in condensing unit electrical enclosure.

**High Pressure Safety:** Reset high pressure control switch. If tripped, install gauges observe operating pressures to determine that compressor discharge pressure is within operating limits. If fans do not come "on", check circuit breaker in condensing unit control panel. For water cooled units, verify water supply and water regulating valve setting.

**Low Pressure Safety:** This switch will automatically reset when pressure comes up to the "cut-in" set point. If tripped, install gauges observe operating pressures to determine that compressor suction pressure is within operating limits. If suction pressure is low, check machine refrigerant charge.

**Note:** When the machine starts after a power failure or after the machine has cycled off on bin control or the "on/off/clean" selector switch, the PLC do not look at the low pressure switch for 90 seconds.

**Compressor Motor Overload Protector (Sentronic before March 2011, CoreSense after March 2011):** Machines are equipped with a compressor protection device that opens in the event compressor temperature or amperage reaches an extreme that could damage compressor. The device automatically resets after compressor has cooled. CoreSense must be reset.

(Note: On VT80 & V100 Only). Note: This sensor is in series with the oil pressure safety switch. Fault #3 can be either compressor motor overload or oil pressure.

**CAUTION:** If machine is off on motor overload protector, control cycle timer and other components will continue to function although the compressor is off. The machine or any of its components can start without warning causing serious injury.

**Bin Control Open:** Adjust thermostat bin control as required. See page 8-3 for bin control error code.

**Faulty Remote Off/On Switch:** Replace if necessary.

**Compressor Contactor Defective:** Check wiring to line contactor to determine that "L" terminals are supplied with power. Check contactor coil for open winding.

**Oil Failure Switch (Sentronic before March 2011, CoreSense after March 2011):** Reset Sentronic oil pressure safety switch. Check compressor oil level. If oil level in sightglass, check oil pressure.

**Note:** Verify proper operation of crankcase heater. Cold starts can cause oil loss.

**Chopper Failure:** If the chopper motor fails to come on, the current sensing relay in the chopper motor circuit will detect the absence of motor current and shut the machine off. See Machine "Freeze-Up".

## MACHINE “FREEZE-UP”

*The following situations may cause machine “freeze-up”:*

1. Harvest hold switch is improperly set
2. Improper fan control setting
3. Low head pressure limiting available gas for defrost
4. Dirty, scratched, or dented evaporator surface
5. Chopper motor or motor contactor defective
6. Interruption of electric service
7. Off on low pressure and reset without clearing tubes.
8. Low pressure safety switch improperly adjusted, causing termination prior to harvest.
9. Loss of water pressure.
10. Defective hot gas solenoid valve.
11. TXV not adjusted properly or functioning properly. Ice freezing too far up tube.

**Note:** If ice is freezing too high (onto the top flange holding the evaporator) the ice may not drop from the evaporator tubing. See page 8-8 for adjusting TXV.

Clearing a “freeze-up can be accomplished by placing “On/Off/Clean” selector switch in the “Clean” position and circulating water over the tubes.

**CAUTION: Clearing “freeze-ups” should be done using only water. Use of any foreign objects (example: hammer or screw driver) may damage tube surface. If tube is dented or scratched, ice will not release properly. This will void the evaporator warranty.**

## ADDITIONAL TROUBLESHOOTING

### **Low Suction Pressure** - Possible causes include:

1. Evaporators froze up
2. Plugged drier
3. Low refrigerant charge
4. Moisture causing freezing @ TXV
5. Low water circulation
6. Faulty TXV
7. Bad hot gas solenoid valve

### **High Head Pressure** - Possible causes include:

1. Plugged condenser
2. Faulty fan motor
3. Faulty fan cycle switch
4. Faulty thermostat at condenser (allowing only one fan to run)
5. Refrigerant overcharge
6. Non condensable present.
7. Electric interruption to condenser (Remote condenser only)

### **Compressor Oil Pressure Fault** - Possible causes include:

1. Faulty oil pressure sensor or module (Sentronic/CoreSense)
2. Clogged oil pump suction screen
3. Low compressor oil
4. Low compressor superheat

### **Compressor Runs But Condenser Fan Does Not:**

1. Faulty fan cycle switch
2. Faulty fan motor
3. Blocked fan blade
4. Electric interruption to condenser (circuit breaker located in condensing unit control panel)

### **Compressor Will Not Run, Water Pump Runs:**

1. Open compressor overload (on VT-40 & VT-60 only)
2. Defective compressor
3. Faulty compressor contactor

### **Water Pump Will Not Run, Compressor Runs:**

1. Faulty pump
2. Electric service interrupted to pump - pump contactor

### **Pump and Compressor Run with Insufficient Water on the Evaporators:**

1. Water system needs cleaning
2. Faulty pump
3. Inadequate water supply
4. Obstructed float assembly
5. Improper float adjustment

### **Chopper motor Fault:**

1. Bad chopper motor
2. Bad chopper motor contactor
3. Machine Froze up

Blank

## 8. Service Operations

### PRINCIPLE OF OPERATION

The Vogt® VT Series line of ice making machines from Vogt® Tube Ice®, LLC, combines state-of-the-art technology and efficiency with a reputation for quality and reliability developed over four decades of manufacturing.

In the Vogt® VT Series icemaker, ice is produced on both walls of vertically suspended cylindrical tubes with recirculating water. As ice is produced, makeup water is fed to the water tank via float valve. Freeze time and harvest time are controlled by a Programmable Logic Controller (PLC).

In freeze cycle, the liquid feed valve is “open” (R404A machines only) and the compressor and water pump are “on”. At the end of the Freeze cycle, the PLC initiates the Harvest cycle where the hot gas solenoid valves and chopper motor are energized, and the water pump is turned “off” and liquid feed valve “closed”.

Bin control or remote on/off switch will allow machine to complete a freeze and harvest cycle prior to interrupting operation. For R404A machines, the machine will go thru a Pumpdown before cycling off.

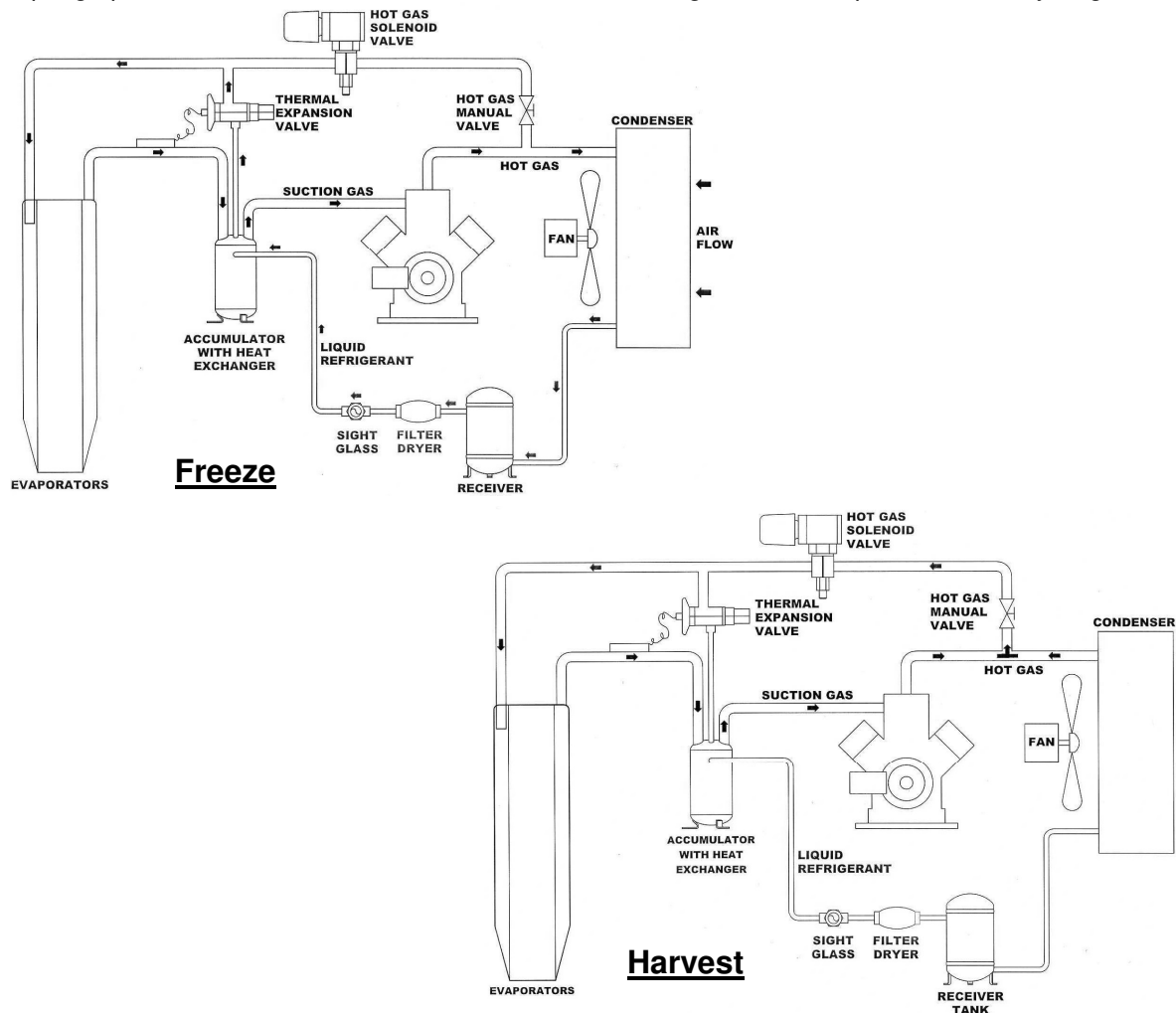


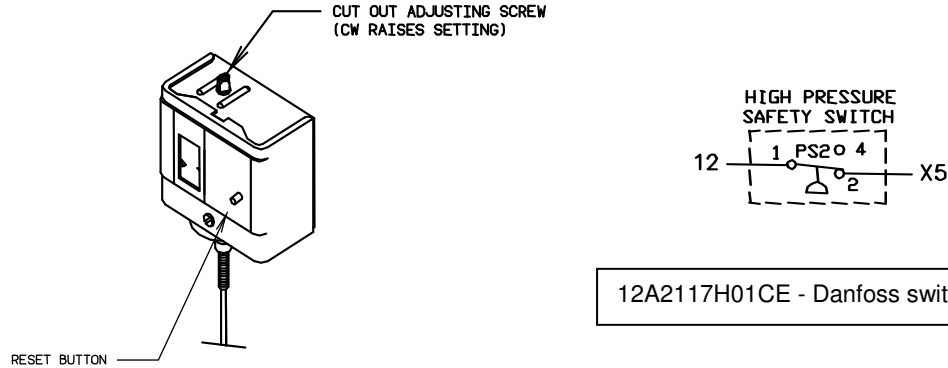
FIGURE 8-1  
Piping Schematic

Pressure Switches

**High Pressure Safety:** 12A2117H01 (Penn) / 12A2117H01CE (Danfoss – for CE machines)

This switch terminates operation of machine when high compressor discharge pressure occurs.

Settings: Cut-Out (“Off”) 300 PSIG (R22) / 350 PSIG (R404A). Manual Reset



12A2117H01CE - Danfoss switch wiring

**FIGURE 8-2A**  
High Pressure Safety Switch

**Low Pressure Safety:** 12A2117B08 (Penn) / 12A2117B03CE (Danfoss – for CE machines)

This switch terminates operation of machine when low suction pressure occurs.

**Note:** When the machine starts after a power failure or after the machine has cycled off on bin control or the “on/off/clean” selector switch, the plc do not look at the low pressure switch for 90 seconds.

Settings: Cut-out (“Off”) 10 PSIG (R22 & R404A)

Cut-in (“On”) 20 PSIG. (R22 & R404A)

**Fan Control Switch:** 12A2117F05 (Penn)

This switch cycles the condenser fan motors to maintain proper discharge pressure.

Settings: Cut-in (“On”) 220 PSIG (R22) / 250 PSIG (R404A)

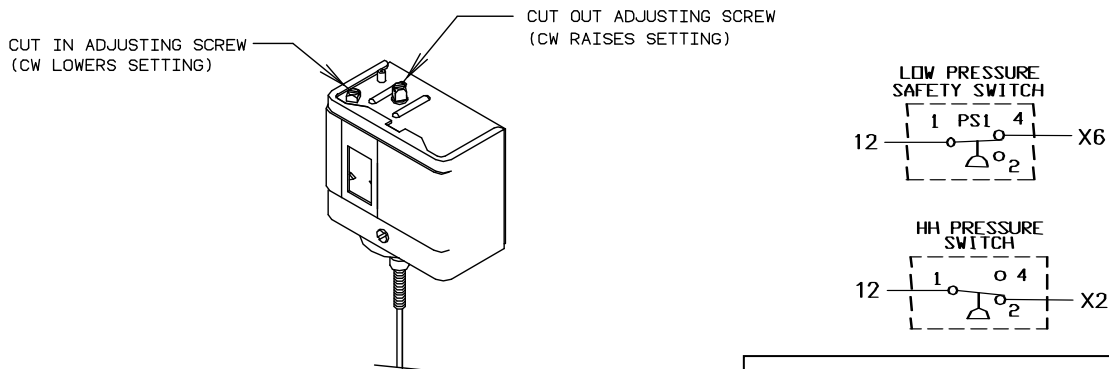
Cut-out (“Off”) 200 PSIG (R22) / 230 PSIG (R404A)

**Harvest Hold Switch:** 12A2117B03 (Penn) / 12A2117B03CE (Danfoss – for CE machines)

This switch stops harvest timer (holds machine in harvest) until the suction pressure comes up to the switch sets set point. Note: In low ambient conditions, the harvest time may be increased by raising the switch Cut-out setting to 70-75 psig.

Settings: Cut-In (“On”) 45 PSIG (R22) / 60 PSIG (R404A)

Cut-out (“Off”) 65 PSIG (R22) / 80 PSIG (R404A)



12A2117B03CE - Danfoss switch wiring

**FIGURE 8-2B**  
Condenser Fan Control Switch, Low Pressure Safety & Harvest Hold Switch

**Oil Failure Switch:** *12A2117A05 (Copeland Sentronic)* On compressors manufactured before March 2011. This device monitors the compressor oil pump differential pressure. If oil pressure drops below 7-9 psig for a period of two minutes, the Sentronic module will open the control circuit contact and shut the machine off. Factory set @ 7-9 psig (Manual reset)

**CoreSense:** Replaces Copeland Sentronic Oil Pressure Safety module on all Discus compressor and the Electronic Motor Protector module in 4D & 6D compressors. Note: 2D & 3D compressor will still have Internal Line Break overload protection.

The oil pressure monitoring portion of the CoreSense will act very similar to the Sentronic Oil Pressure Safety switch. A current transformer (CT) in the compressor junction box determines when the compressor is running and starts monitoring oil pressure.

The CoreSense module has power applied at all times to allow for more detailed fault notification. An LED will flash when a fault occurs. The number of flashes will identify the fault condition.

# of Flashes	Condition
1	Oil Pressure
2	Motor Protection Trip
3	Discharge Temperature (optional add-on)
4	Current Sensor Fault
5	Communication Error

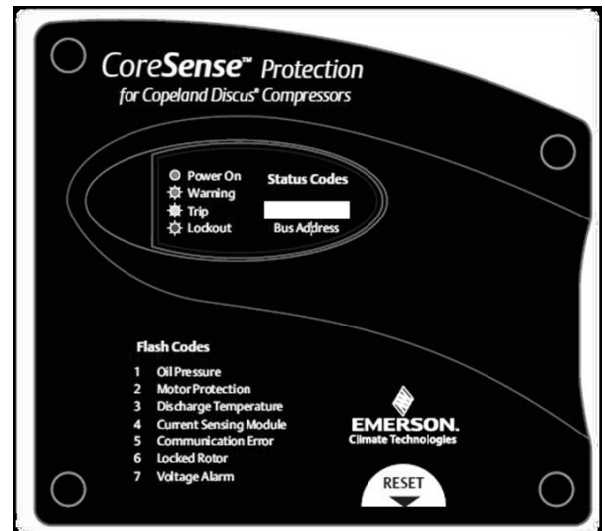
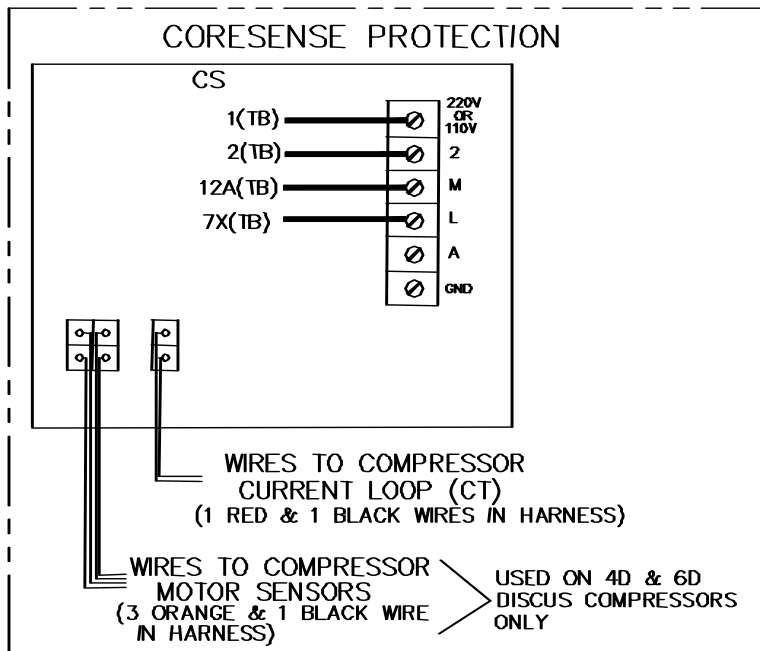
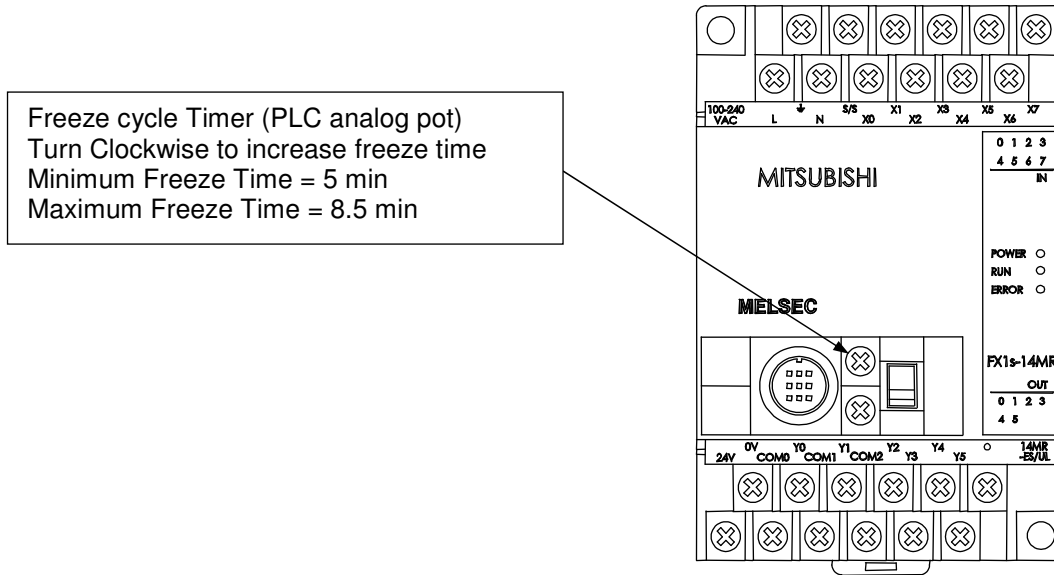


FIGURE 8-3  
Copeland CoreSense



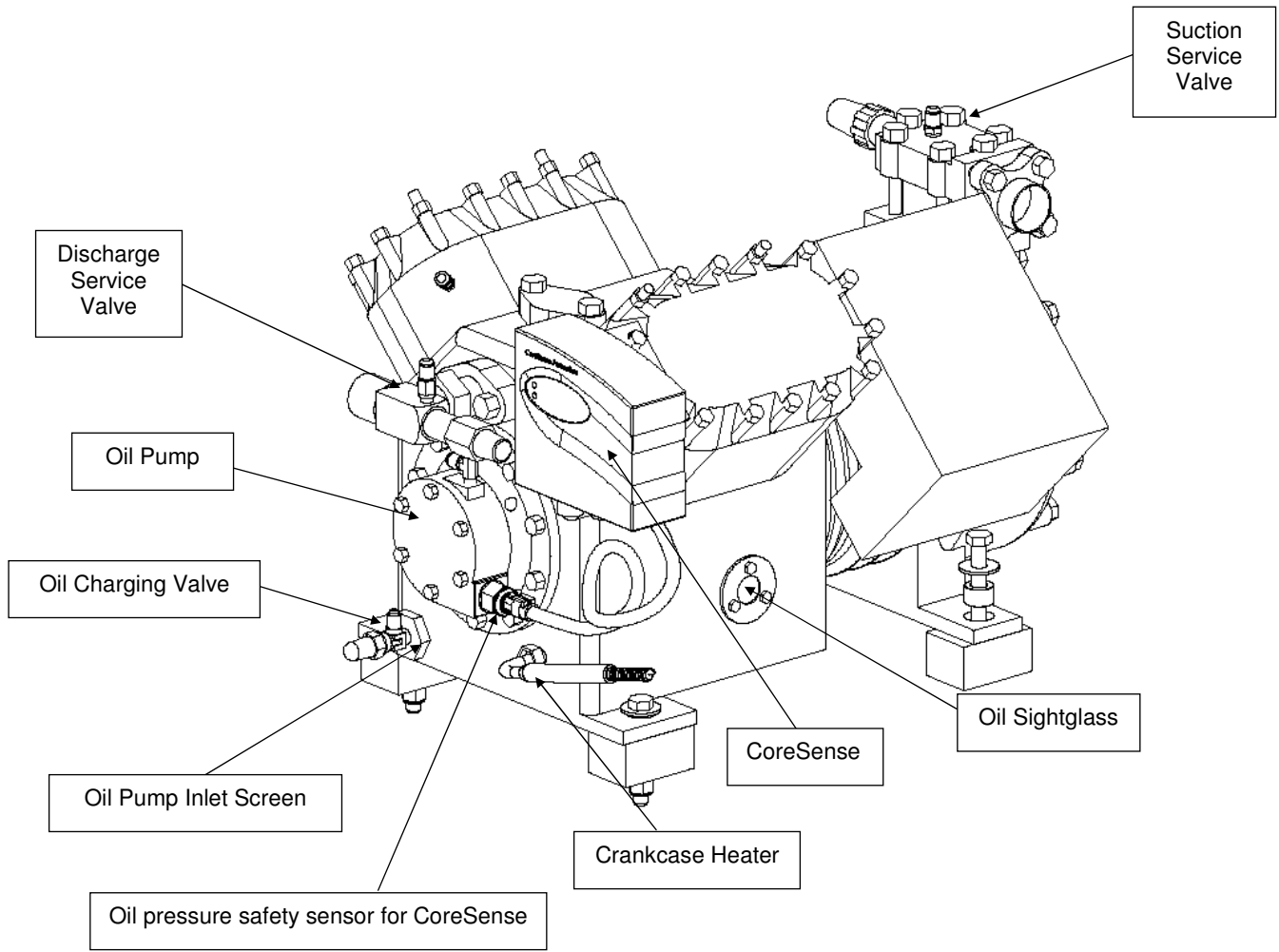
**PLC (Programmable Logic Controller).** The VT-Series ice machine is controlled by a PLC (Programmable Logic Controller). The PLC controls the sequence of events and monitors the ice machine functions. The operational sequences of the VT-Series ice machine can be described best as a series of six different modes. Each mode identifies and defines a sequence of events that occur while in that mode and thereby cause it to move to the next mode. Only one mode is active at a time.



**FIGURE 8-5**  
**PLC (Programmable Logic Controller)**

	#	Description		#	Description
Inputs	0	Current Sensing Relay (chopper)	Outputs	0	Fault Indicator light
	1	“On” Selector Switch/Bin Control		1	Liquid Feed Solenoid (R404A machines only)
	2	HH Pressure Switch		2	Compressor
	3	Manual Harvest (Start) Button		3	N/A
	4	Clean Switch		4	Water Pump
	5	High Pressure Safety Switch		5	Chopper/Hot Gas Valve/Defrost Loop valve or Suction Stop Valve (VT100)
	6	Low Pressure Safety Switch			
	7	Oil Press Safety /Comp Motor OL			

**TABLE 8-1**  
**PLC Inputs/Outputs**

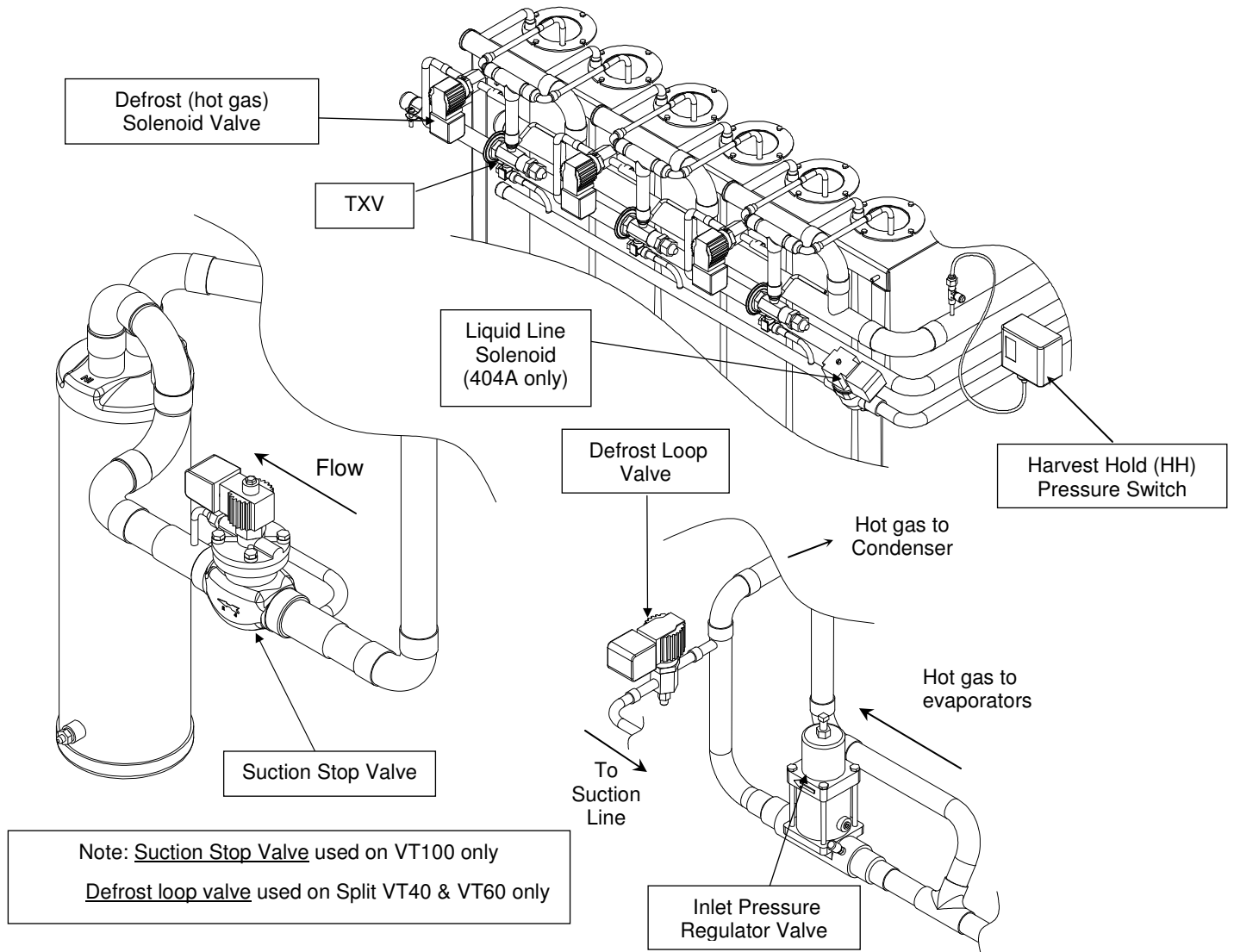


**FIGURE 8-6**  
**Copeland Discus Compressor (12.5 HP Shown)**

Description		Refrigerant	Vogt #	Copeland #
Compressor	VT-40 (5 1/2HP)	R22/404A	12A2110A117	3DB3F33KL-TFC-100
	VT-60 (7 HP)	R22/404A	12A2110A110	3DS3F46KL-TFC-100
	VT100 (12 1/2 HP)	R22/404A	12A2110A129	4DJNF76KL-TSK-C00
Crankcase Heater	100 W (insert type)	R22/R404A	12A7509E12	518-0028-01
Oil Pressure safety switch	Sentronic3 Module and Sensor		12A2117A05	585-1076-02
CoreSense Protection	Module and Sensor		12A2117A07	943-0109-00
Oil safety – sensor only	For Sentronic, Sentronic 3 or CoreSense		12A2117A0501	998-0162-00

**TABLE 8-2**

**Compressor / Compressor Parts**



Description		Vogt #	Manufacture	
Defrost Solenoid Valve (Hot gas valve)	1/2" Solenoid valve	12A4200A406	Sporlan	
Defrost Loop Valve (Split VT40 & VT60)	1/2" (N.C.) Rebuild Kit	<a href="#">12A4199V53</a>	Sporlan	
	Coil	<a href="#">12A2105C16</a>	Sporlan	
Suction Stop Valve – N.O. (VT100)	1 5/8" Solenoid valve	<a href="#">12A4200A1104</a>	Sporlan	
	1 5/8" (N.O.) Rebuild Kit	<a href="#">12A4199V47</a>	Sporlan	
	Coil (for N.O. valve)	<a href="#">12A2105C04</a>	Sporlan	
Liquid Line Solenoid Valve (R404A machines only)	5/8" Extended End (VT40)	<a href="#">12A4200A0504</a>	Sporlan	
	7/8" Standard length, B25S (VT60-100)	<a href="#">12A4200A0707</a>	Sporlan	
	7/8" valve, B19S (after 4/2011)	12A4200A0708	Sporlan	
	5/8" (N.C.) Rebuild Kit	<a href="#">12A4199V38</a>	Sporlan	
	7/8" (N.C.) Rebuild Kit – for B25S valve	<a href="#">12A4199V39</a>	Sporlan	
	7/8" (N.C.) Rebuild Kit – for B19S valve	<a href="#">12A4199V43</a>	Sporlan	
Inlet Pressure Regulator Valve	1 1/8" Regulator valve	<a href="#">12A4200N0903</a>	Parker	
TXV	R22 Machines		<a href="#">12A4200C0305</a>	Sporlan
	R404A Machines	VT40, 60 & 80	<a href="#">12A4200C0320</a>	Sporlan
		VT100	<a href="#">12A4200C0321</a>	Sporlan

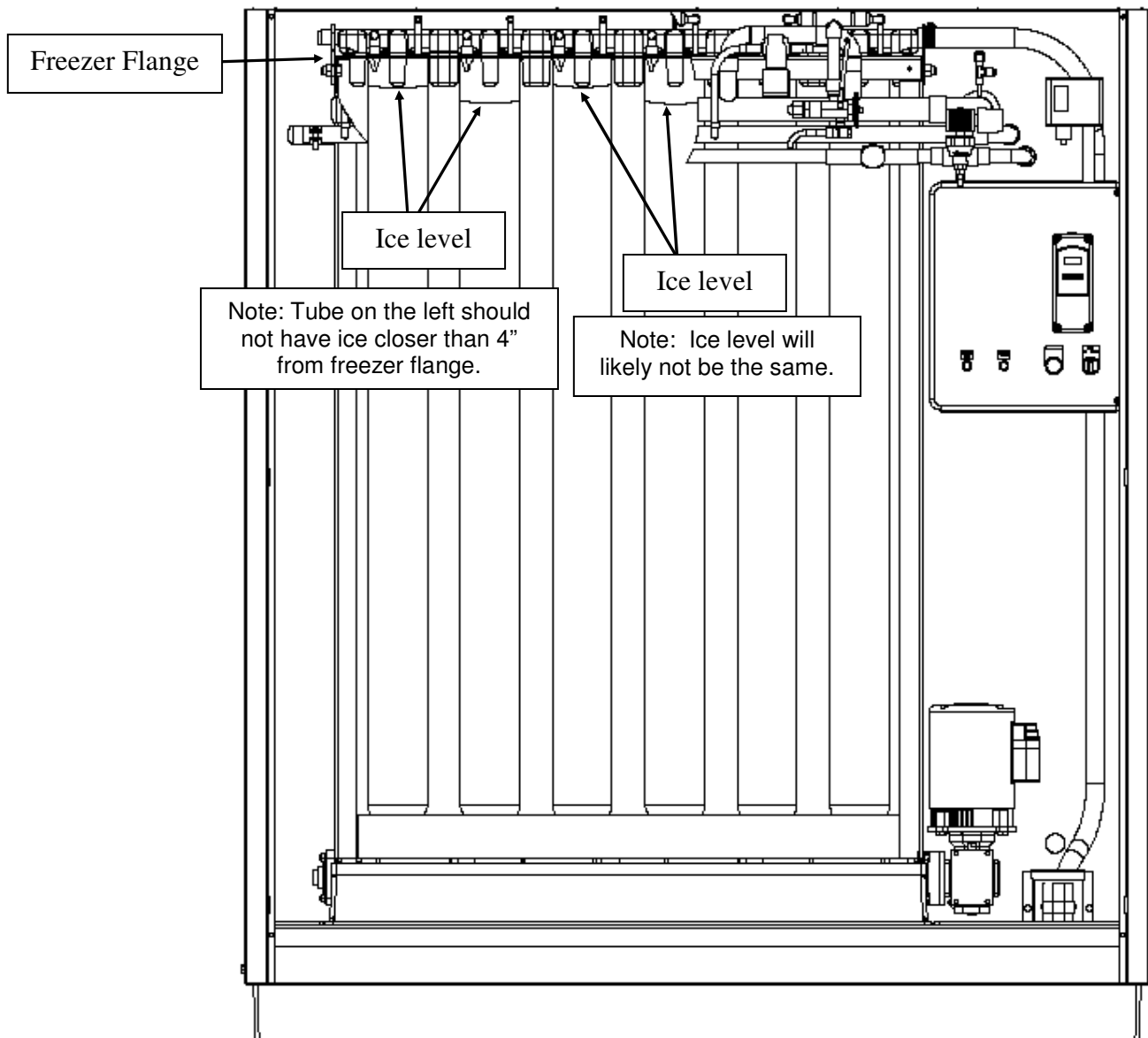
TABLE 8-3

TXV, Regulator Valve & Solenoid Valves

## Service Operations

**Adjusting TXV:** Ice should start forming on the evaporator tubes approximately four inches from the top flange. Freezing too high on the evaporator may cause ice to hang up on tubes and not release properly. Freezing too high can also indicate that the superheat is too low and that liquid refrigerant may be coming back to the compressor. This liquid refrigerant can damage or destroy the compressor.

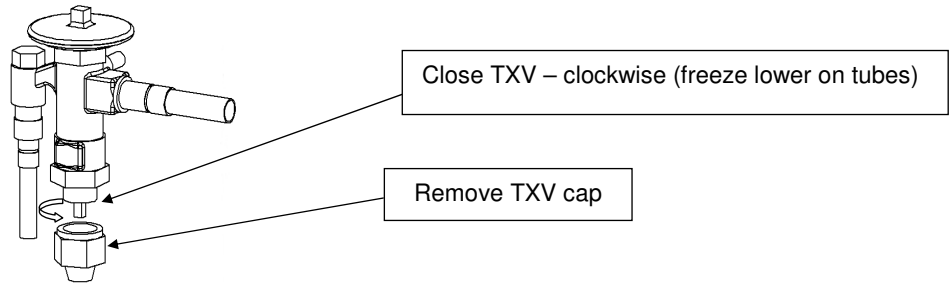
**Note:** On VT100's, the ice may not freeze all the way up on all tubes. It is normal for one of the tubes being fed by a particular TXV to have ice 2 or 3 inches higher than the other. This is normal and will not affect capacity. **DO NOT OPEN TXV** in an attempt to get ice to form equally on both freezer tubes. This can cause one of the tubes to be overfed and bring liquid refrigerant back to the compressor. This can damage and/or shorten the life of the compressor.



**Ice Levels on Freezer Tubes (VT100)**

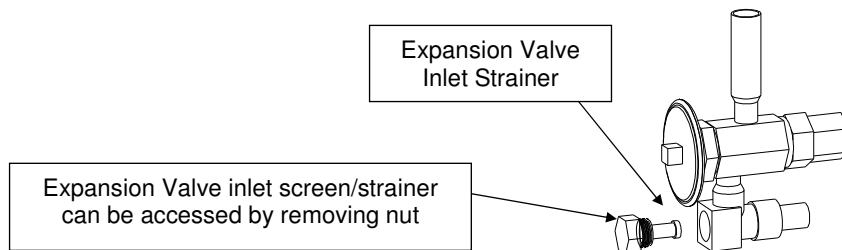
To lower ice level, the TXV can be closed by running the stem in. Do this by turning the TXV stem clockwise as shown below. (looking up at the valve stem)

**Note:** Close TXV ¼ turn at a time. Observe several cycles before making further changes.



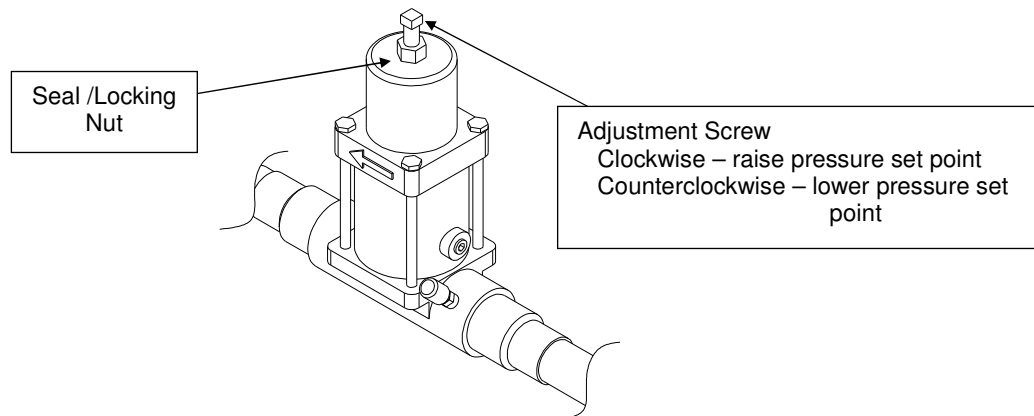
If ice is not freezing high enough on the evaporator tubes, the TXV can be opened by backing the stem out. Do this by turning the TXV stem counter-clockwise. (looking up at the valve stem)

**Note:** Check expansion valve inlet strainer before opening valve. Clean strainer if necessary. Open TXV ¼ turn at a time. Observe several cycles before making further changes.

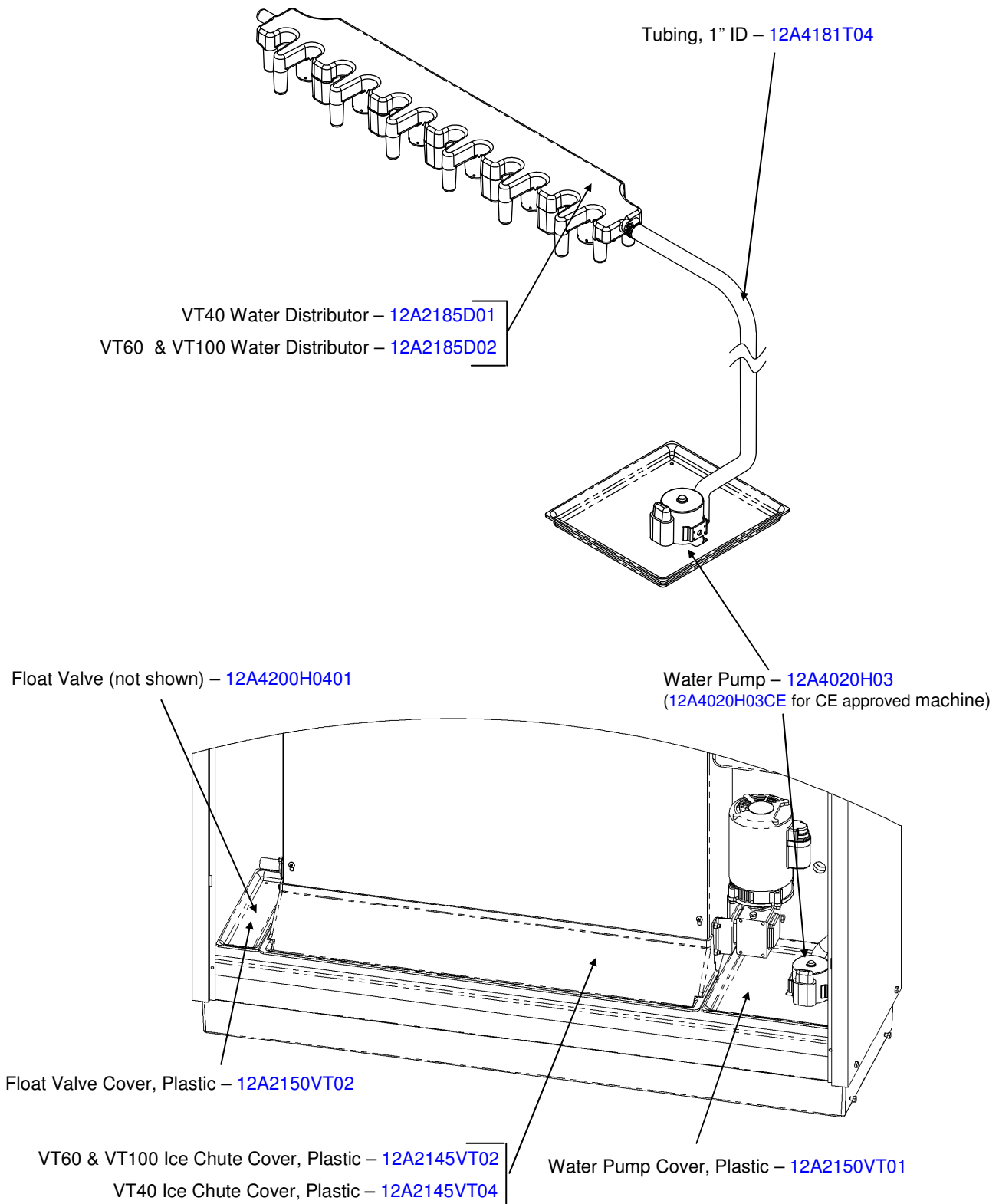


**FIGURE 8-7**  
**Adjusting TXV**

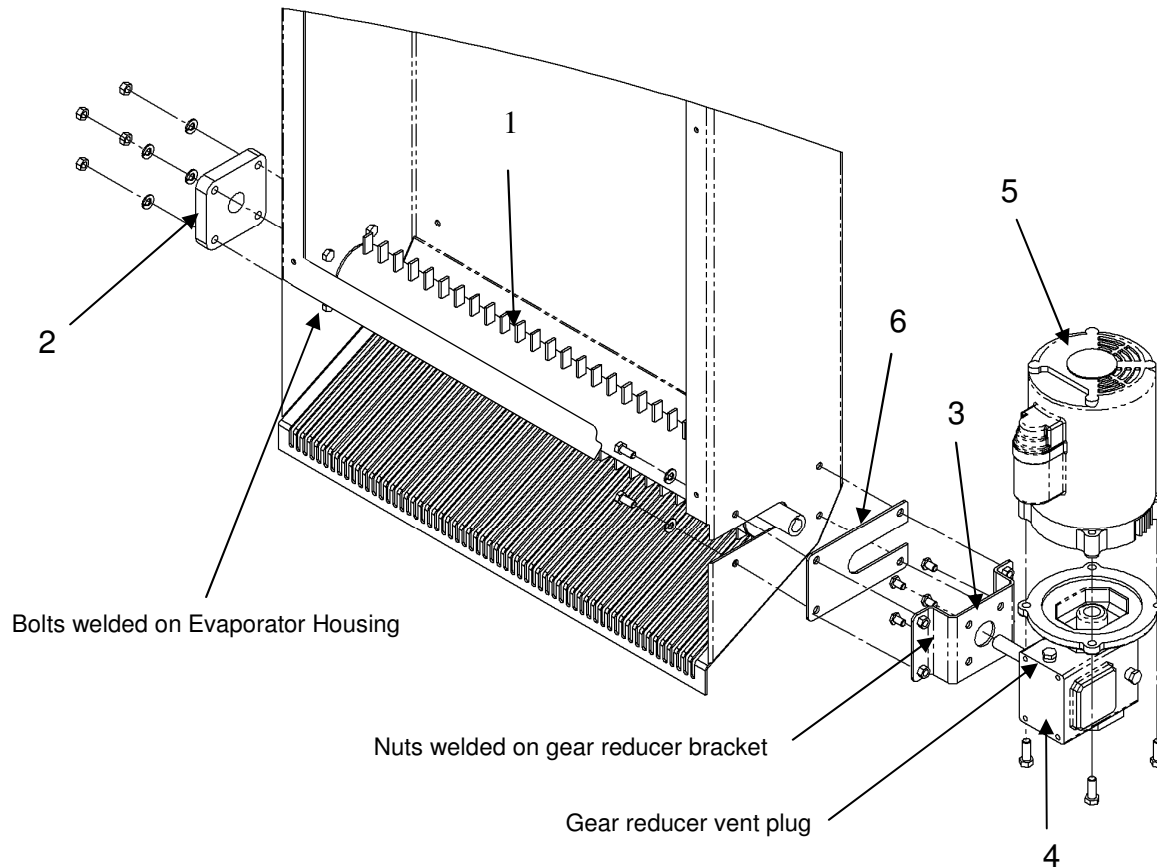
**Inlet Pressure Regulator:** This regulator valve is used on the split VT40, split VT60 and VT100. The purpose of this valve is to maintain head pressure during the harvest cycle. (Set point = 160-170 psig) Valve will be closed when inlet pressure is below the set point. This will allow all the discharge gas to go to the evaporators during the harvest cycle. When pressure rises above the set point, valve will open and allow discharge gas to pass through to the condenser.



**FIGURE 8-8**  
**Inlet Pressure Regulator**

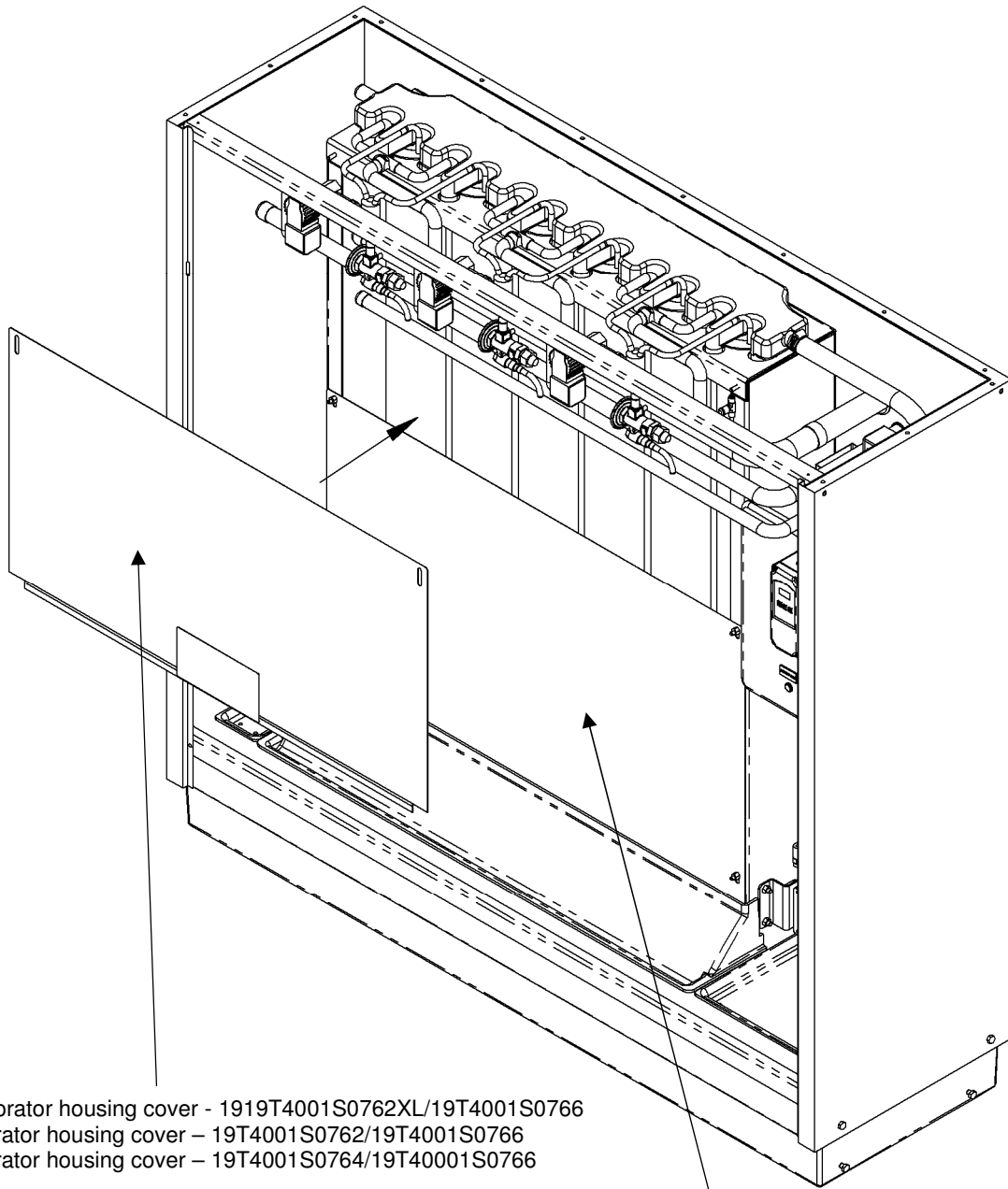


**FIGURE 8-9**  
**Water Tank Parts**



	Description	Vogt #
1	Chopper assembly	19T2161C03 (VT60, VT80 &VT100) 19T2161C04 (VT40)
2	Bearing, Nylon/Stainless Ball Bearings	12A2020M19
3	Bracket, for Gear Reducer	19T4001S0740
4	Gear Reducer, 5:1	12A4030R14
5	Motor, ½ HP, 3600 RPM, 56C Face, 208-230V, 1 Phase, 50/60Hz	12A2900M0511 (12A2900M0511CE – CE approved)
6	Plate, UHMW, for Gear Reducer Bracket	19T2150VT01

**FIGURE 8-10**  
**Chopper Assembly**



VT100 Upper Evaporator housing cover - 1919T4001S0762XL/19T4001S0766

VT60 Upper Evaporator housing cover - 19T4001S0762/19T4001S0766

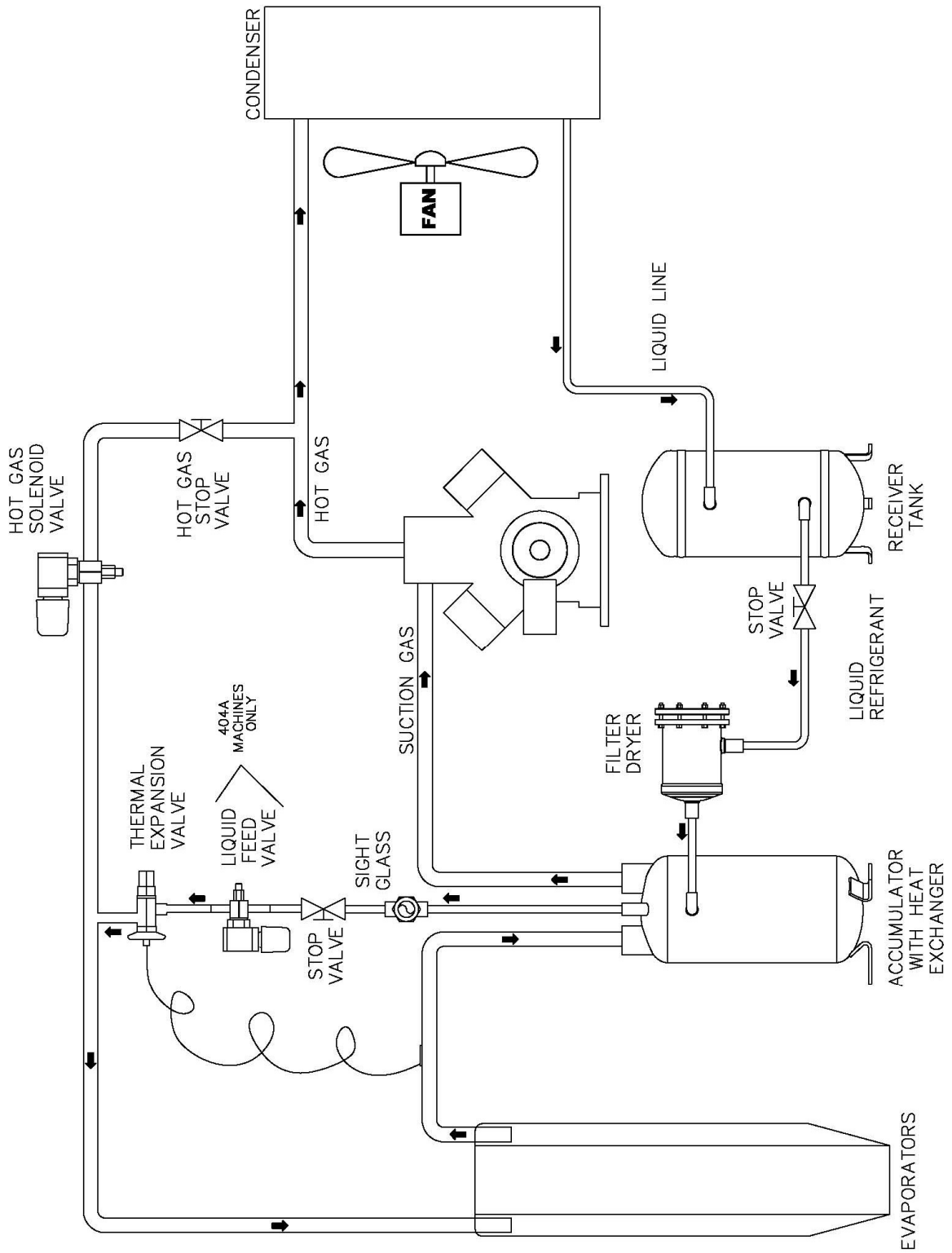
VT40 Upper Evaporator housing cover - 19T4001S0764/19T4001S0766

VT60 / VT100 Lower Evaporator housing cover - 19T4001S0763

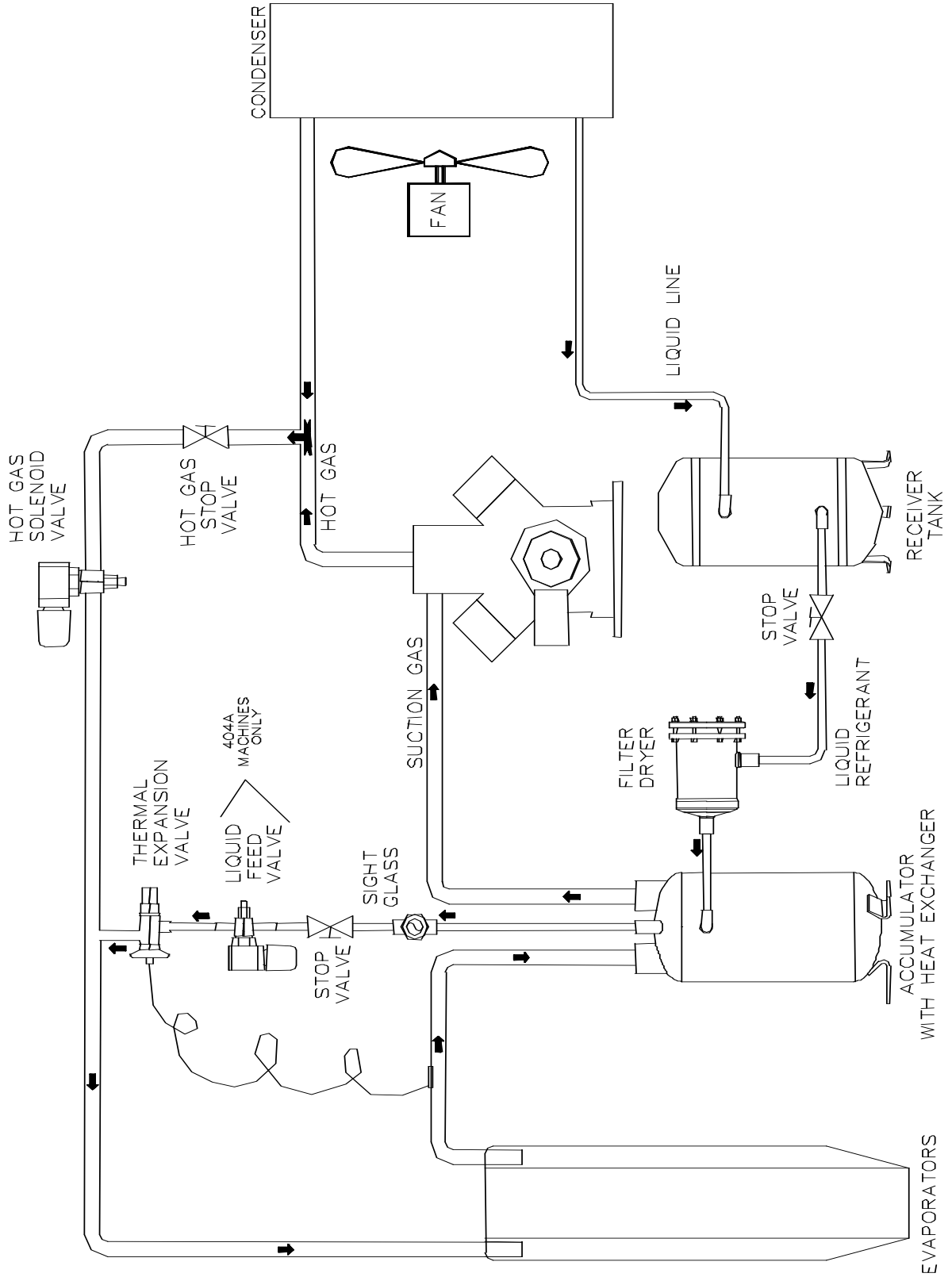
VT40 Lower Evaporator housing cover - 19T4001S0765

**!!!! CAUTION !!!!**  
**Never Operate Machine with Lower Evaporator Housing Cover Removed. Disconnect Power to machine before removing lower evaporator cover.**

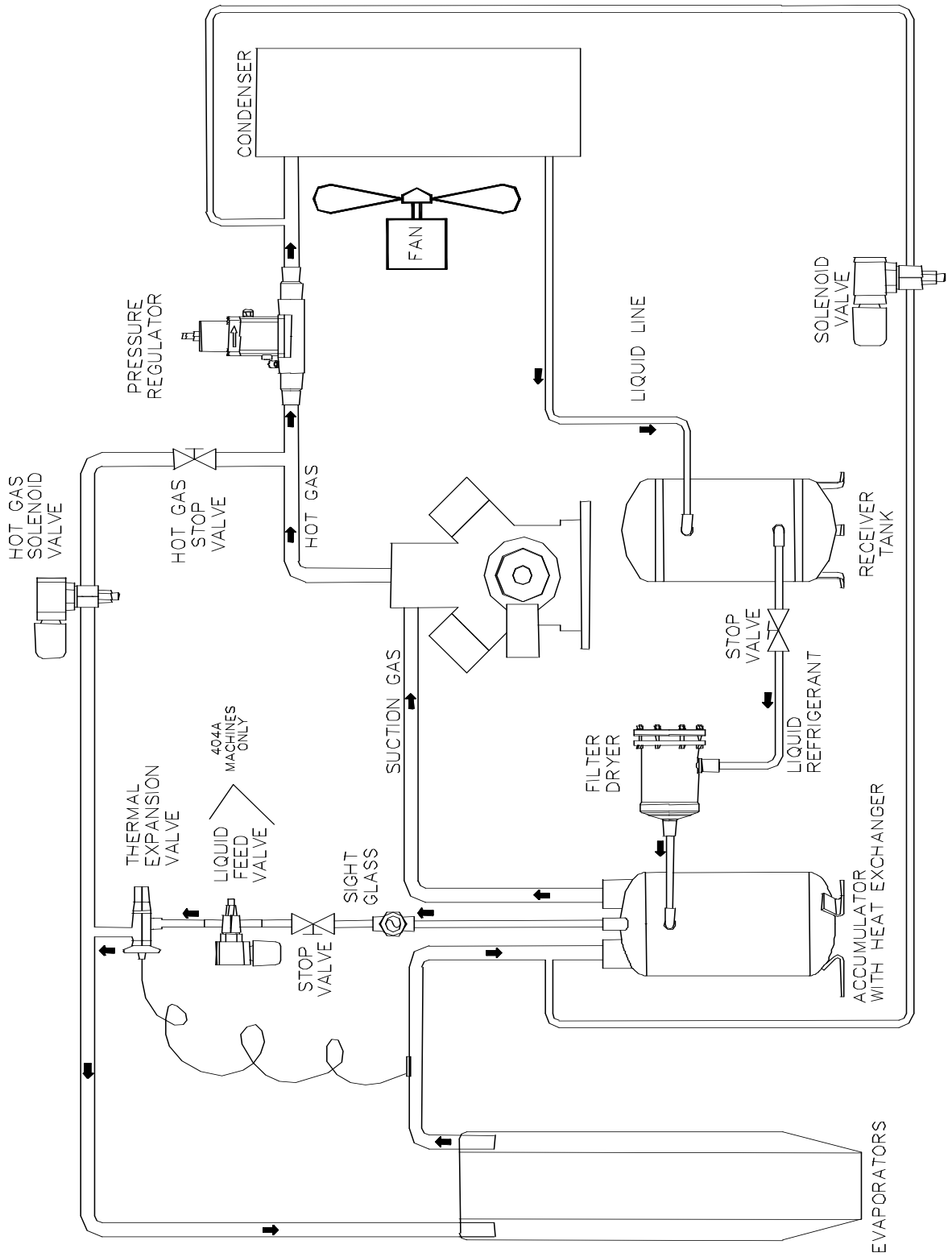
**FIGURE 8-11**  
**Evaporator Covers**



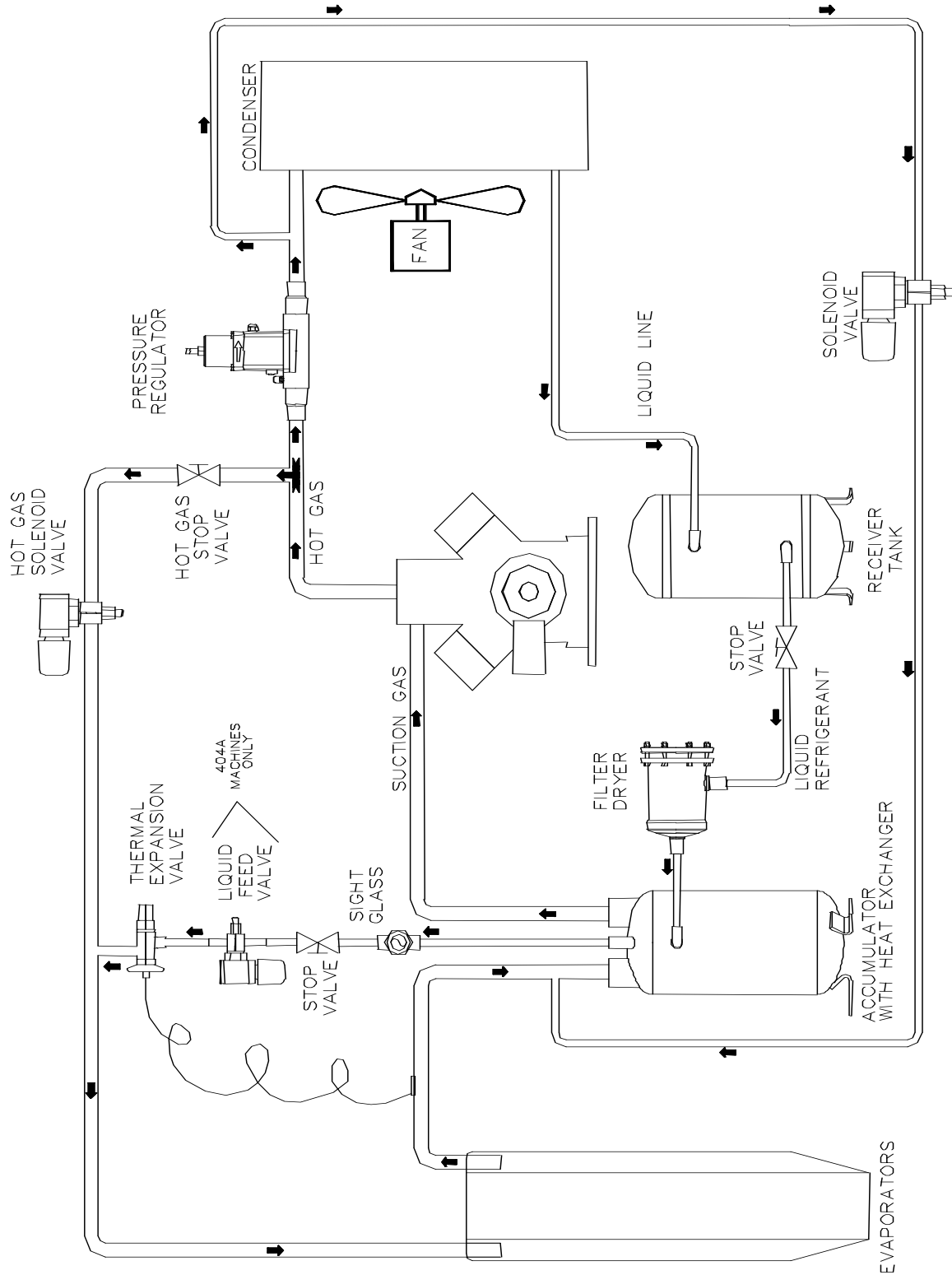
**FIGURE 8-12**  
**Freeze Cycle Schematic**  
**Skid mounted (Package VT40 & VT60)**



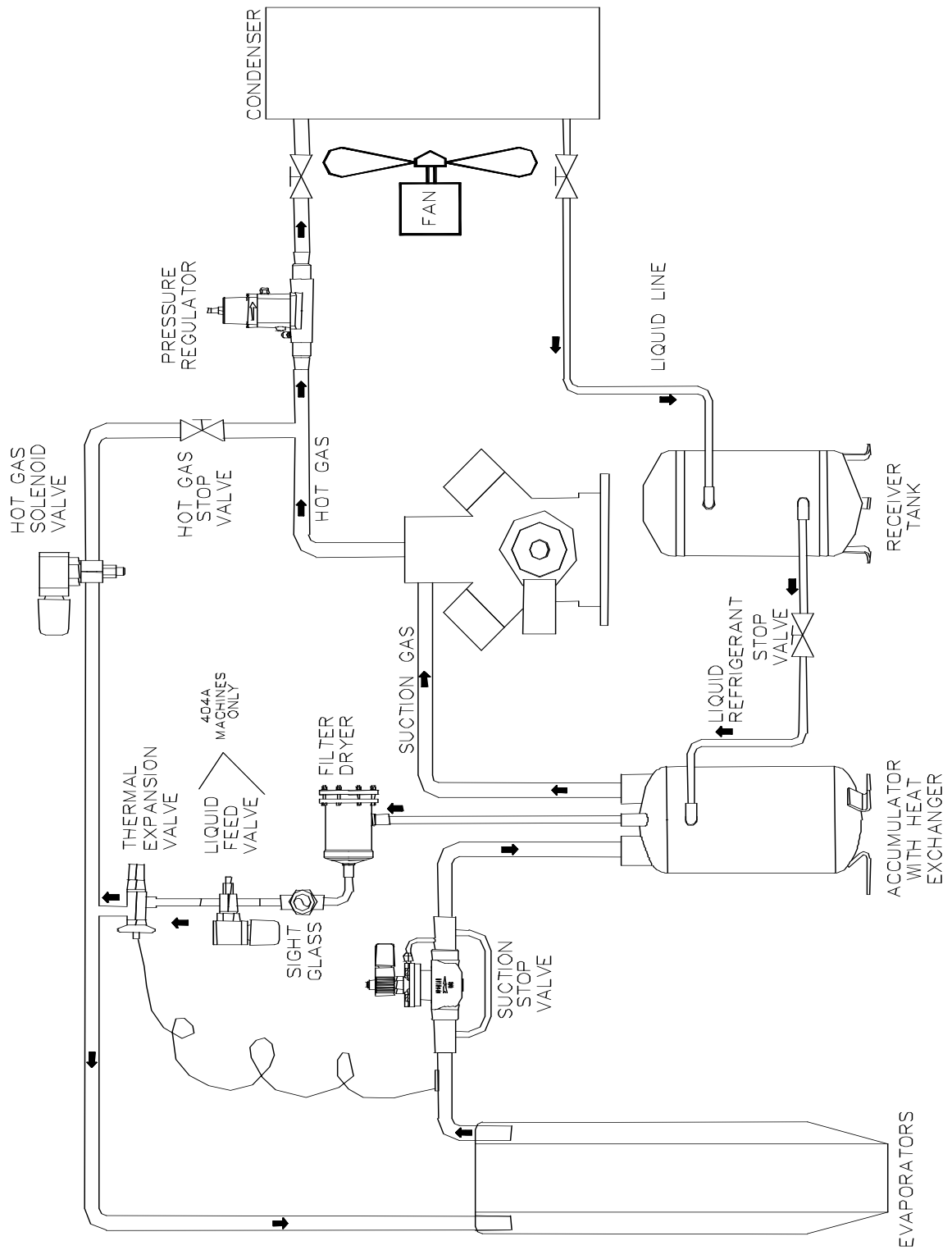
**FIGURE 8-13**  
**Harvest Cycle Schematic**  
**Skid mounted (Package VT40 & VT60)**



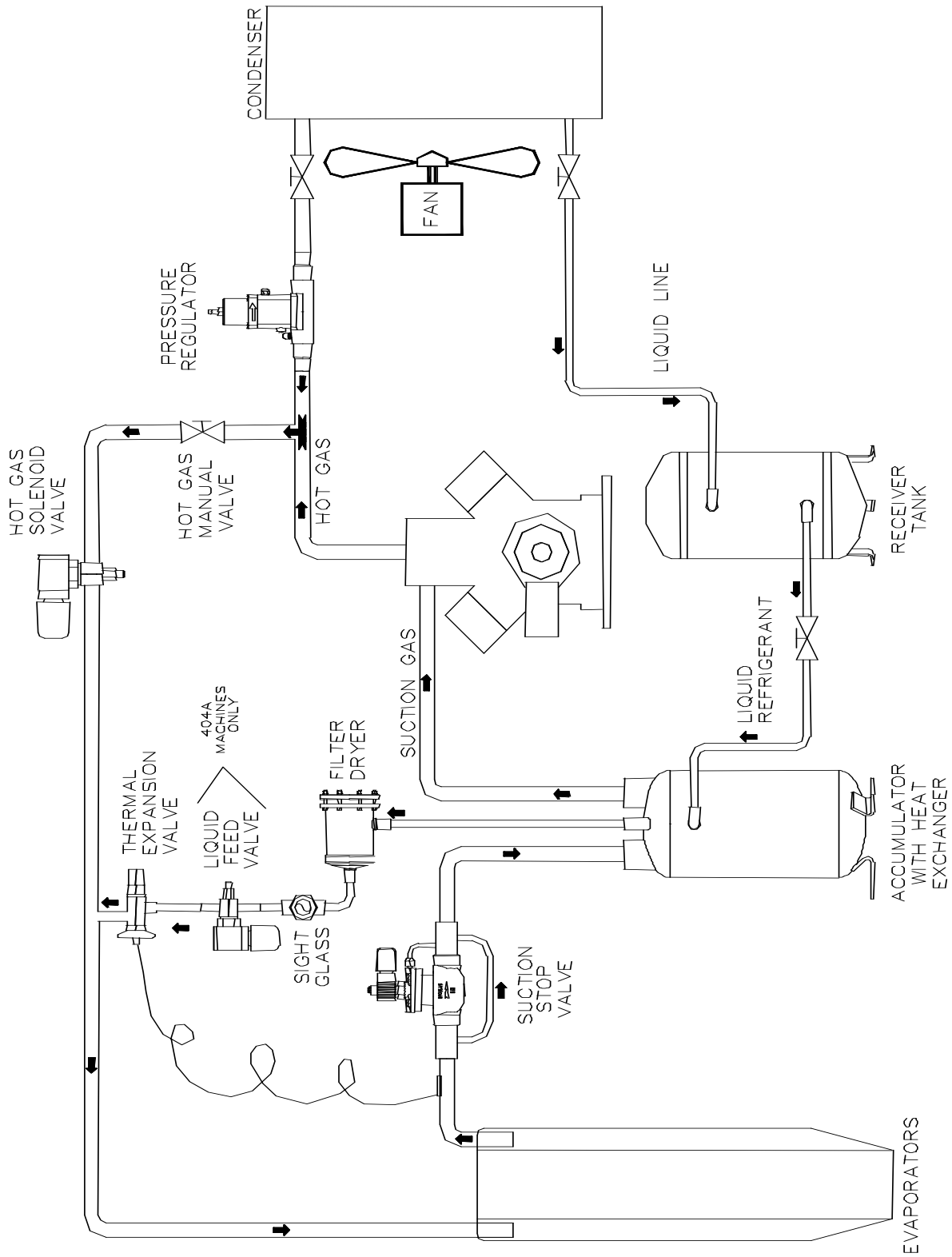
**FIGURE 8-14**  
**Freeze Cycle Schematic (w/Defrost Loop Valve)**  
**Split System (VT40 & VT60)**



**FIGURE 8-15**  
**Harvest Cycle Schematic (w/Defrost Loop Valve)**  
**Split System (VT40 & VT60)**



**FIGURE 8-16**  
**Freeze Cycle Schematic (w/Suction Stop Valve)**  
**(VT80 & VT100)**



**FIGURE 8-17**  
**Harvest Cycle Schematic (w/Suction Stop Valve)**  
**(VT80 & VT100)**

## Replacement Parts List

**Control Panel Components (Low-Side)**

<b>Part Number</b>	<b>Req'd</b>	<b>Description</b>
12A2117G09	1	ELECTRONIC BIN THERMOSTAT
12A2117G0901	1	ELECTRONIC THERMOSTAT PROBE
12A7500E61	1	A/B SELECTOR SWITCH, 3 POSITION, <b>SS, Ice-Clean-Off Selector Switch</b>
12A7500E73	1	CONTACT BLOCK/MOUNTING LATCH, 2-NO, <b>For Ice-Clean-Off Switch</b>
12A7500E56	1	A/B PUSH BUTTON SWITCH (GREEN), <b>PB1- Manual Harvest/Start Switch</b>
12A7500E75	1	CONTACT BLOCK/MOUNTING LATCH, 1-NO, <b>For Manual Harvest/Start Switch</b>
12A7536M01	1	PROGRAMMABLE CONTROLLER (PLC)
12A7516E23	2	A/B CONTACTOR, 9-AMP, 3-POLE, 208/240V W/1-NO AUX, <b>Cutter or Pump Contactor (CU or P)</b>
12A7515E21	1	CONTROL CIRCUIT BREAKER, 3 AMP, 2-POLE, <b>CB3/CB4</b>
12A2117B03	1	PRESSURE SWITCH (PENN), <b>HH-Harvest Hold Pressure Switch</b>
12A2117B03CE	1	PRESSURE SWITCH (DANFOSS) – CE APPROVED MACHINE
12A7520E33	1	INDICATOR LIGHT, 250V RED LENSE, <b>1LT-Fault Indicator Light</b>
12A7520E36	1	INDICATOR LIGHT, 28VDC (SPECIAL)
12A7520E34	1	INDICATOR LIGHT, 250V AMBER LENSE, <b>2LT-Control Power Indicator Light</b>
12A7537S07	1	CURRENT SENSING RELAY

**Control Panel Components (Condensing Unit)**

12A7516E29	1	A/B CONTACTOR, 43-AMP, 3-POLE, 208/240V W/1-NO AUX <b>C-Compressor Motor Contactor for VT40</b>
12A7516E30	1	A/B CONTACTOR, 72AMP, 3-POLE, 208/240V COIL <b>C-Compressor Motor Contactor for VT60, VT80 &amp; VT100</b>
12A7518E30	1	A/B AUX. CONTACT, 3A, 1 NO/1 NC, (SIDE MOUNT) <b>Auxiliary Contact for Compressor Contactor, VT60, VT80 &amp; VT100</b>
12A7515E18	1	PUMP/CUTTER MOTOR CIRCUIT BREAKER, 2-POLE, 10 AMP <b>CB1-Control Circuit (Low-Side)</b>
12A7515E19	1	CONDENSER FAN CIRCUIT BREAKER, 2-POLE, 15 AMP <b>CB2-Control Circuit (Condensing Unit)</b>
12A2117A05	1	SENTRONIC OIL PRESSURE SAFETY CONTROL
12A2117B08	1	LOW PRESSURE CONTROL 20"-100#, 1/4"SAE, 36" CAP TUBE
12A2117H01	1	HIGH PRESSURE CONTROL, 50-450#, 1/4"SAE, 36" CAP TUBE
12A2117F05	1	CONDENSER FAN CONTROL SWITCH
12A2117G09	1	ELECTRONIC BIN THERMOSTAT – Remote condenser for VT80 & VT100 only <b>(Condenser Fan Cold Weather Thermostat)</b>
12A7519E38CE	1	TRANSFORMER, 250VA, 400/200V PRI/120V SEC, 50/60HZ, FOR 120V WATER PUMP, <b>FOR CE APPROVED MACHINE</b>
12A7537S06	1	POWER LINE FILTER, 10A, <b>For CE Approve Machine</b>

**Chopper Assembly**

19T2161C03	1	CHOPPER ASSEMBLY FOR VT60, VT80 & VT100 (B-SERIES)
19T2161C04	1	CHOPPER ASSEMBLY FOR VT40 (B-SERIES)
12A2020M19	1	BEARING, NYLON/STAINLESS STEEL BALL BEARING 1" BORE
12A4030R14	1	GEAR REDUCER, GROVE 5:1 RATIO
12A2900M0511	1	CHOPPER MOTOR, 1/2 HP, 3600 RPM, 115/230V-1PHASE
12A2900M0511CE	1	CHOPPER MOTOR, 1/2HP, 3600 RPM, 220V, 50HZ-1PHASE – <b>For CE Approve Machine</b>

**Circulating Water**

12A4200H0401	1	FLOAT VALVE, 1/2" ROBERTS #RM214
12A4020H03	1	PUMP, HARTELL, 1/12HP, 208-230V, 50/60HZ <b>Replaces Beckett, Pump #12A4020B01</b>
12A4020H03CE	1	PUMP, ANJON, 1/5HP (144W), 115V, 50/60HZ – <b>For CE Approved Machine</b>
12A4181T04	6	TUBING, TYGON B-44-3, 1-1/4" OD x 1" ID <b>Circulating Water Tubing (Priced per Ft.)</b>
12A2185D01	1	WATER DISTRIBUTOR FOR VT40
12A2185D02	1	WATER DISTRIBUTOR FOR VT60, VT80 & VT100
12A2150VT01	1	WATER PUMP COVER FOR VT (B-SERIES)
12A2150VT02	1	WATER FLOAT VALVE COVER FOR VT (B-SERIES)
12A2145VT02	1	ICE CHUTE COVER FOR VT60, VT80 & VT100 (B-SERIES)
12A2145VT04	1	ICE CHUTE COVER FOR VT40 (B-SERIES)

**Liquid Line**

<u>Part Number</u>	<u>Req'd</u>	<u>Description</u>
12A4200C0305	2 or 3	R22 - EXPANSION VALVE, SPORLAN, <b>2 for VT40, 3 for VT60, VT80 &amp; VT100</b>
12A4200C0320	2 or 3	R404A - EXPANSION VALVE, SPORLAN, <b>2 for VT40, 3 for VT60 &amp; VT80</b>
12A4200C0321	3	R404A - EXPANSION VALVE, SPORLAN, <b>VT100</b>
12A4200A0504	1	SOLENOID VALVE, 5/8" ODC, Normally Closed, Sporlan, 208/230V COIL (Liquid Feed) <b>VT40 (R404A only)</b>
12A4199V38		REPAIR KIT FOR 5/8" SPORLAN Solenoid Valve, B14S2 OR E10S2
12A4200A0707	1	SOLENOID VALVE, 7/8" ODC, Normally Closed, Sporlan, 208/230V COIL (Liquid Feed) – B25S
12A4200A0708 (AFTER 4/2011)		SOLENOID VALVE, 7/8" ODC, Normally Closed, Sporlan, 208/230V COIL (Liquid Feed) – B19S <b>VT60, VT80 &amp; VT100 (R404A only)</b>
12A4199V39		REPAIR KIT FOR 7/8" SPORLAN Solenoid Valve, B25S2 OR E25S2
12A4199V43		REPAIR KIT FOR 7/8" SPORLAN Solenoid Valve, B19S2 OR E19S2
12A2625S02	1	LIQUID INDICATOR, 7/8" ODC, <b>VT60, VT80 &amp; VT100</b>
12A2625S03	1	LIQUID INDICATOR, 5/8" SAE, <b>VT40</b>
12A2140C01	1	FILTER DRIER CORE, <b>VT60, VT80 &amp; VT100</b>
12A2195D28	1	DRIER, FILTER, SPORLAN, <b>VT40</b>
12A2000A07	1	SUCTION ACCUMULATOR, 1-5/8" x 3/4" (After 5/2005)
12A2000A12		SUCTION ACCUMULATOR, 2-1/8" x 7/8"

**Thawing Gas Line**

12A4200A0406	1	SOLENOID VALVE, 1/2" ODC, Normally Closed SPORLAN, 208/230V COIL (Hot Gas valve)
12A4199V53	1	REPAIR KIT FOR 1/2" SPORLAN ME10S2 OR E10S2
12A2105C16	1	COIL, #MKC-2 FOR SPORLAN 208/240V-50/60HZ

**Condensing Unit**

12A2110A117	1	VT40 – COMPRESSOR	(R22), 3DB3F33K0-TFC-100, 208/230-3-60, 5.5HP
12A2110A130			(R404A), 3DB3F33KE-TFC-100, 208/230-3-60, 5.5HP
12A2110A110	1	VT60 – COMPRESSOR	(R22), 3DS3F46K0-TFC-100, 208/230-3-60, 7HP
12A2110A131			(R404A), 3DS3F46KE-TFC-100, 208/230-3-60, 7HP
12A2110A122	1	VT80 – COMPRESSOR	(R22), 4DL3F63K0-TSK-253, 208/230/400/460, 10HP
12A2110A128			(R404A), 4DL3F63KE-TSK-253, 208/230/400/460, 10HP
12A2110A125	1	VT100 – COMPRESSOR	(R22) 4DT3F76K0-TSK-200, 208/230/400/460, 12.5HP
12A2110A129			(R404A) 4DT3F76K0-TSK-200, 208/230/400/460, 12.5HP
12A7509E12	1	CRANKCASE HEATER, 100 WATT INSERTION <b>Replaces Bolt-on Heater</b>	
12A2117A05	1	SENTRONIC OIL PRESSURE SAFETY CONTROL	
12A2117A0501	1	SENTRONIC OIL PRESSURE SENSOR	
12A4200N0903	1	INLET PRESSURE REGULATOR, 1 1/8" (VT80's & VT100's or VT40 & VT60 split system) <b>Hot gas loop valve</b>	
12A4200A0406	1	SOLENOID VALVE, 1/2" ODC, Normally Closed, SPORLAN, 208/230V COIL (Defrost Loop valve) <b>Split VT40 &amp; VT60</b>	
12A4199V53	1	REPAIR KIT FOR 1/2" SPORLAN ME10S2 OR E10S2	
12A2105C16	1	COIL, #MKC-2 FOR SPORLAN 208/240V-50/60HZ	
12A4200A1104	1	SOLENOID VALVE, 1 5/8" ODC, Normally Open, SPORLAN, 208/230V COIL (Suction Stop valve) <b>VT80 &amp; VT100</b>	
12A4199V47	1	REPAIR KIT FOR 1 5/8" SPORLAN Normally Open valve	
12A2600S06	1	GASKET, INLET SIDE OF HSE-15 CONDENSER – <b>For Water Cooled</b>	
12A2600S07	1	GASKET, RETURN SIDE OF HSE-15 CONDENSER – <b>For Water Cooled</b>	
12A2115A0103CE	1	WATER COOLED CONDENSER, (CE APPROVED) – <b>For Water Cooled, CE Machine</b>	
12A4200E1001	1	WATER REGULATING VALVE – <b>For Water Cooled Machine</b>	

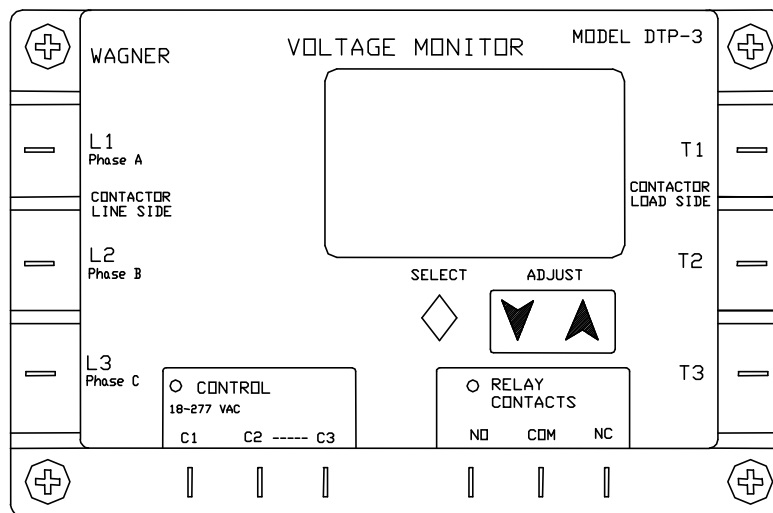
**TABLE 8-4**  
**Replacement Parts List**

## 9. Additional Product Information

### Power Monitor

#### **Wagner Model #: DTP-3**

All Vogt Tube-Ice machine models are available from the factory with a three phase line voltage power monitor with LCD display. The units are also available for after market or retrofit installation. These units monitor line voltage inputs from 190 to 610 volts and provide protection against line voltage variances which can damage or destroy the compressor motor. Features include automatic system shutdown and restart based on current line conditions, a voltmeter, and a non-volatile system memory so settings are retained even if power is lost. If machine is ordered with this option the power monitor can be factory set to customer specifications. The Vogt Part number for a power monitor retrofit kit is [12A7700K01](#).



#### **The Display**

The display normally shows the AB BC CA line voltages.

If the unit is waiting on a timer, that timer will be displayed. The timer display may be switched off by pressing SELECT. The LCD will then display the normal AB BC CA line voltage pairs.

Pressing the SELECT button once shows the contactor load side voltages (if the load side option is connected). The display automatically returns to the display of line side voltage after a few seconds.

**Press the Select button to step through the parameters.** As you step through the parameters, the selected parameter will flash. Use the up and down arrow keys to adjust to the desired operating value.

#### **Parameter limits**

Parameter	Minimum	Maximum	Default	Recommended Settings	Unit
Line Side Voltage (Nominal Voltage)	90	650	<b>208</b>	<b>Supply voltage</b>	Volts
Over Voltage (tolerance)	6	18	<b>12</b>	<b>10</b>	%
Under Voltage (tolerance)	6	18	<b>12</b>	<b>10</b>	%
Phase Unbalance	2	25	<b>6</b>	<b>5</b>	%
Lockout Time (Delay on Break)	0.1	25	<b>0.5</b>	<b>120</b>	Seconds
Delay Time (Delay on Make)	0	30	<b>0</b>	<b>0</b>	Seconds
Response Time (Delay on Fault)	0.1	20	<b>2</b>	<b>2</b>	Seconds
Control Mode	Off / Auto / On		<b>Auto</b>	<b>On</b>	N/A
Contactur Test	OFF	5	<b>OFF</b>	<b>OFF</b>	Volt Diff

## Additional Product Information

## Parameters adjustment (in order of display)

Active display of Line Voltage (this is the default normal display)

Active display of Load Side Voltage (if connected)

Voltage Set Point

(VAC Flashes) The value may be adjusted by pressing the up and down arrows. This may be set to the normal operating voltage of the device being protected in one volt increments.

Under/over Voltage Tolerance in %

(UNDERVOLTAGE/OVERVOLTAGE flashes)

The value may be adjusted by pressing the up and down arrows.

Imbalance Voltage Tolerance in %

(% IMBALANCE flashes) The value may be adjusted by pressing the up and down arrows.

Lockout Time in seconds

(SECONDS flashes) The value may be adjusted by pressing the up and down arrows. (This is the delay on break timer value)

Delay time in seconds and tenths of seconds

(RESP. SECONDS flashes) The value may be adjusted by pressing the up and down arrows. This is the time that a fault is allowed before shutdown occurs.

Control mode

(ON OFF AUTO flashes) The value may be adjusted to OFF (load will not turn on), ON (load will turn on whenever there are not faults and timers are finished) and AUTO (Load will turn on when there is a control input).

Contactor fault monitor mode

(CONTACTOR FAULT flashes) This option allows you to monitor the contactor and lock it out if the line voltage and load side varies by more than 5 volts. Pressing the up and down arrows selects off (default) or on. The load side of the contactor must be connected to the load terminals of the DTP-3 to use this option.

Display of fault memories

(MEM flashes) Pressing up or down displays the last fault conditions that took the unit off line. The first 25 faults are recorded. The top number displayed represents the fault memory. The middle number represents the total number of faults that have occurred since the fault memory was cleared.

To clear the memory, press and hold the up and down keys until the display is cleared.

**Notes**

**If you press SELECT and do not change a parameter by pressing the up or down arrow keys, the DTP-3 automatically returns to displaying the line voltage in a few seconds.**

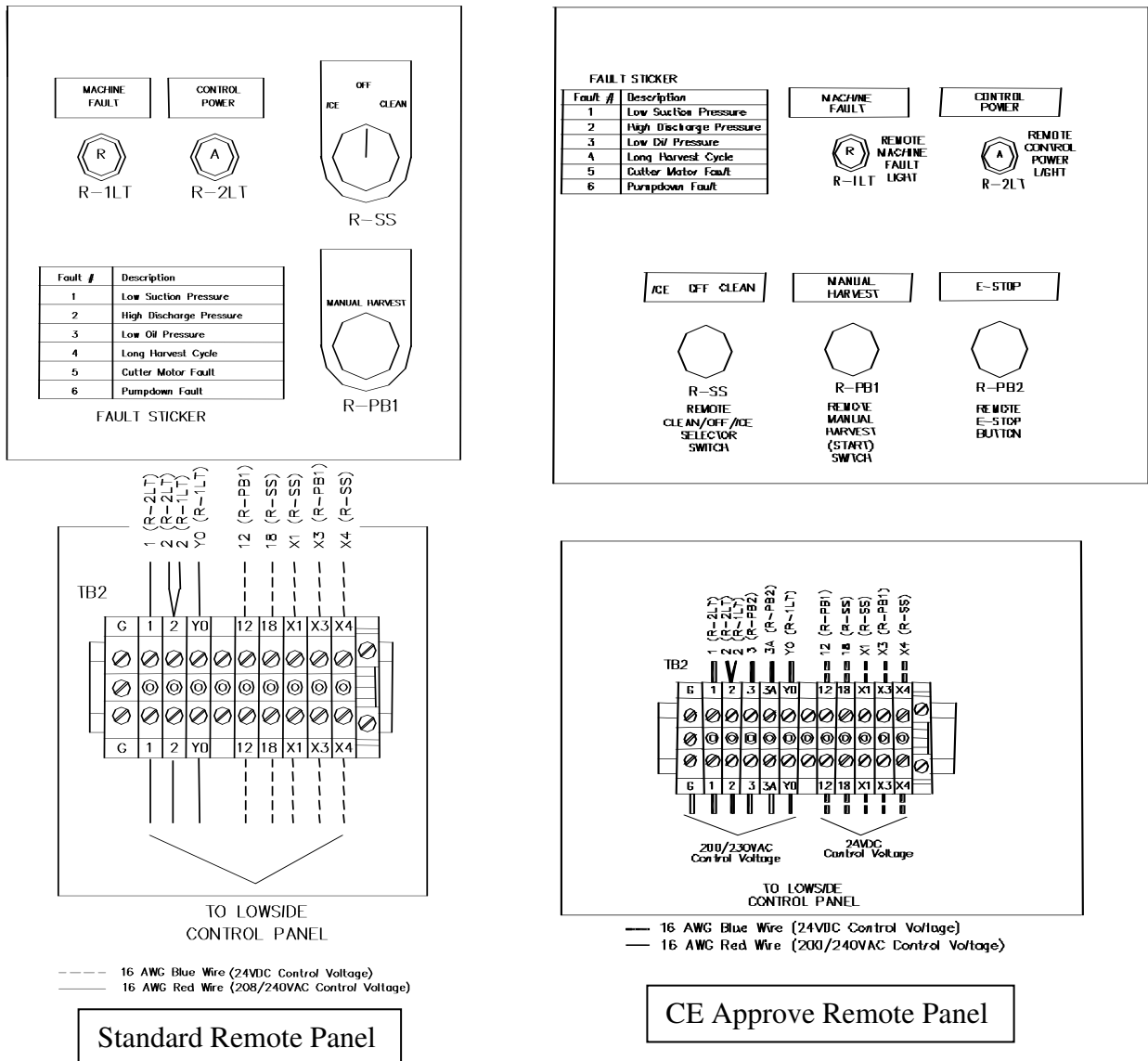
**The new settings are saved in permanent memory when the display returns to displaying the line voltage. The new settings may be verified by pressing the select button to sequence through the various parameters.**

**To prevent tripping on a 1 volt change, the DTP-3 automatically calculates cut-in voltages for the return from undervoltage conditions. The cut-out voltage is always based on user voltage and tolerance settings, while the cut-in voltage is 3% closer to the nominal voltage setting. This quality is sometimes referred to as hysteresis. This is to help reduce oscillation that may occur on weak power distribution system. When the load is switched off due to undervoltage, the line voltage will increase. Without the hysteresis, the monitor would switch the load back on, the line voltage would again drop, and cause a continuous on-off-on cycling.**

**Remote Switch Box**

**VT Remote Switch Box (Optional)**

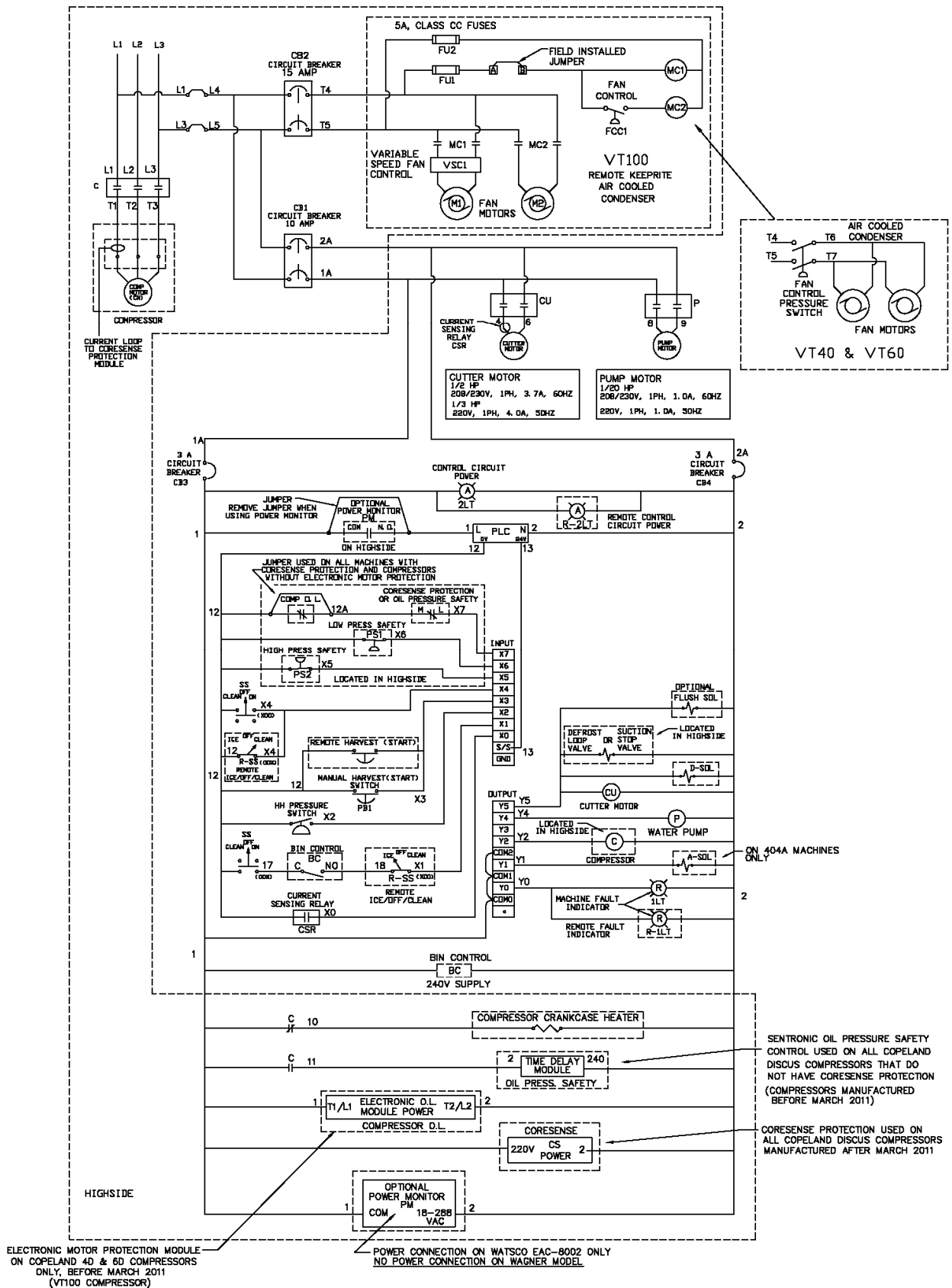
This small control panel (box) consists of Ice/Off/Clean selector switch, a Manual Harvest/Start button and two indicator lights (power & fault) and can be added to any VT machine. This panel will contain both 208/230VAC and 24VDC. Remote switch box for CE approved machines will have an Emergency Stop button.



**Remote Switch Box Parts**

	PART #	DESCRIPTION
R-PB1	12A7500E56	PUSH BUTTON, MOMENTARY, GREEN
	12A7500E75	CONTACT BLOCK, 1 N.O. W/MOUNTING LATCH
R-PB2	12A7500E130	E-STOP, PUSH-PULL, RED (CE MACHINE ONLY)
	12A7500E76	CONTACT BLOCK, 1 N.C. W/MOUNTING LATCH (CE MACHINE ONLY)
R-SS	12A7500E61	3 POS. SELECTOR SWITCH OPERATOR
	12A7500E73	CONTACT BLOCK, 2 N.O. W/MOUNTING LATCH
R-1LT	12A7520E33	INDICATOR LIGHT, 250V, RED LENSE
R-2LT	12A7520E34	INDICATOR LIGHT, 250V, AMBER LENSE

**FIGURE 9-1**  
**Remote Switch Box Layout**



**FIGURE 9-2A**  
Standard Electrical Schematic - 208/230V (With Remote Switch Box)

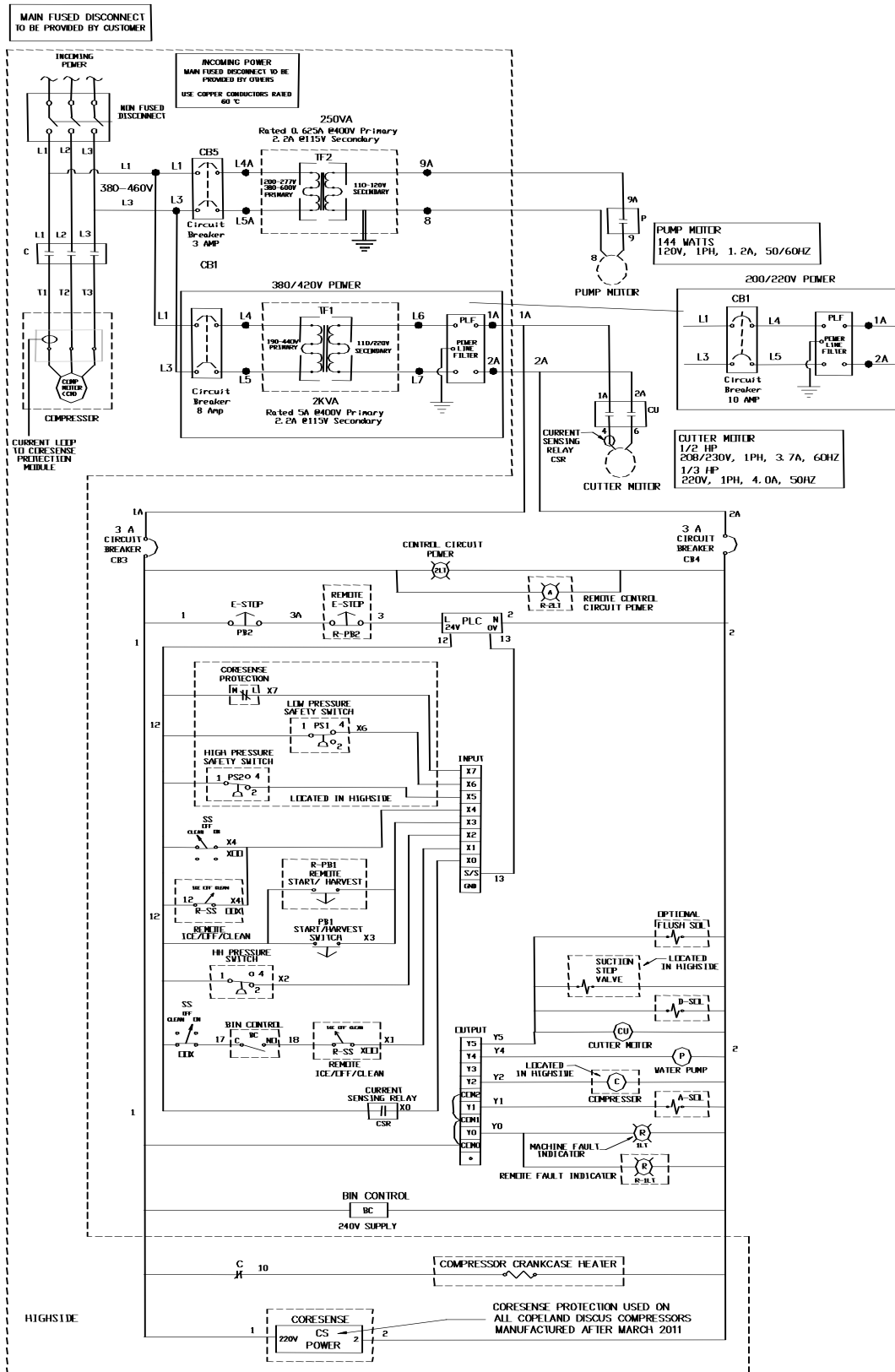


FIGURE 9-2B

CE Approved Electrical Schematic - 208/230V (With Remote Switch Box)

Blank

# VOGT® VT MACHINE BASIC PRODUCT WARRANTY

Vogt Ice, LLC. hereinafter referred to as *SELLER*, warrants every **Vogt® VT Machine Model VT40, VT60 and VT100** to be free from defects in material and workmanship, if properly installed, maintained and operated under normal use for a period of 24 months from date of original installation or 24 months from date of shipment from *SELLER'S* plant if the *SELLER* does not have an accepted start-up form on file. The obligation of the *SELLER* under this warranty is limited to the repair or replacement of parts or assemblies that in the *SELLER'S* opinion are defective, F.O.B. the factory, not including the compressor.

The component warranty is not applicable to installation related components such as remote air-cooled condenser lines, bins, external electrical components and external water and drain lines.

The compressor warranty is for a period of 12 months from date of original installation or 12 months from date of shipment from *SELLER'S* plant if the *SELLER* does not have an accepted start-up form on file.

The date of installation for both the component and compressor warranties will be determined by the *SELLER* from an accepted machine start-up form. To secure prompt and continuing warranty service, the start-up form must be fully completed and sent to the *SELLER* within thirty (30) days from the installation date.

Any alteration in material or design of *SELLER'S* product or component parts thereof by *PURCHASER* or others without written authorization by *SELLER*, problems with the electrical supply, water supply, flood, storm or other acts of God will void all obligations of *SELLER* regarding the product and any associated warranty herein stated or implied.

*SELLER'S sole liability shall be exclusively as set forth herein, and SELLER shall not be liable for any incidental or consequential damages due to its breach of any warranty herein contained, or otherwise. Without limitation to the foregoing, in no event shall SELLER be liable for the loss of the product or for the loss of use of any other product, process, plant, equipment, or facilities of the PURCHASER whether partially or wholly due to defects in material and/or workmanship and/or design of SELLER'S product, and in no*

*event shall SELLER be liable for removal of appurtenances or incidentals such as connections, pipework and similar items of obstruction or for any cost brought about by the necessity of removing the product from its point of installation.*

## **LOSS OF REFRIGERANT AND REPLACEMENT THEREOF IS NOT COVERED BY THIS WARRANTY.**

***SELLER makes no warranty of any kind whatsoever, express or implied, other than as specifically stated herein; and there are no warranties of merchantability and/or fitness for a particular purpose which exceed the obligations and warranties specifically stated herein.***

## **TEN-YEAR EXTENDED WARRANTY**

At the termination of the two year component warranty period above, *SELLER* hereby extends this warranty for eight years to cover **EVAPORATOR ASSEMBLIES**. *The extended warranty, as it applies to the EVAPORATOR covers only those machines installed in THE UNITED STATES OF AMERICA AND IT'S TERRITORIES.*

Damage to evaporator tubes as a result of expansion caused by re-freezing of ice, dents or scratches caused by abuse or corrosion damage due to water quality is specifically excluded.

These extensions of warranty apply only to **VOGT® VT MACHINE MODELS VT-40, VT-60 and VT-100** for the exclusive use of the *PURCHASER* or original end user, as defined above. All other obligations, terms and conditions of the Basic Product Warranty apply to the Extended Warranty.

***Vogt® and Tube-Ice® are registered trademarks of Vogt Ice LLC, 1000 West Ormsby Ave., Louisville, Kentucky 40210***

