

# VULCAN

## CATALOG OF REPLACEMENT PARTS

### SCALEBLOCKER™ WATER FILTRATION SYSTEM

MODEL

SPS600V

SPS620V

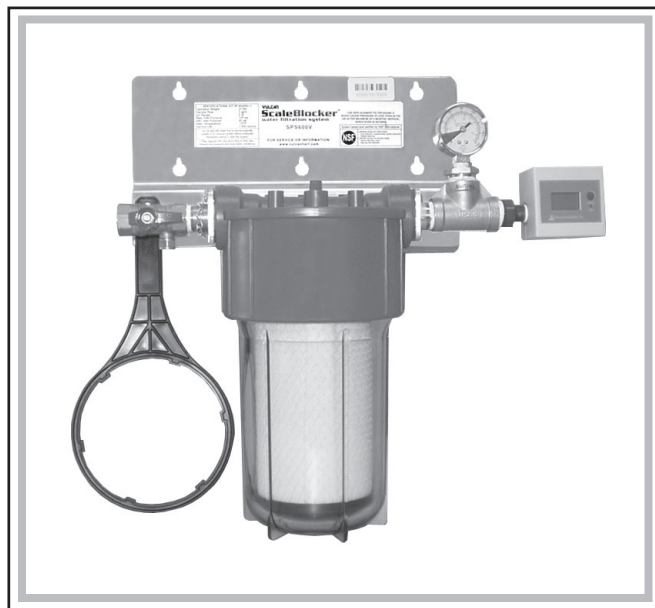

**For additional information on Vulcan-Hart or to locate an authorized parts and service provider in your area, visit our website at [www.vulcanhart.com](http://www.vulcanhart.com)**

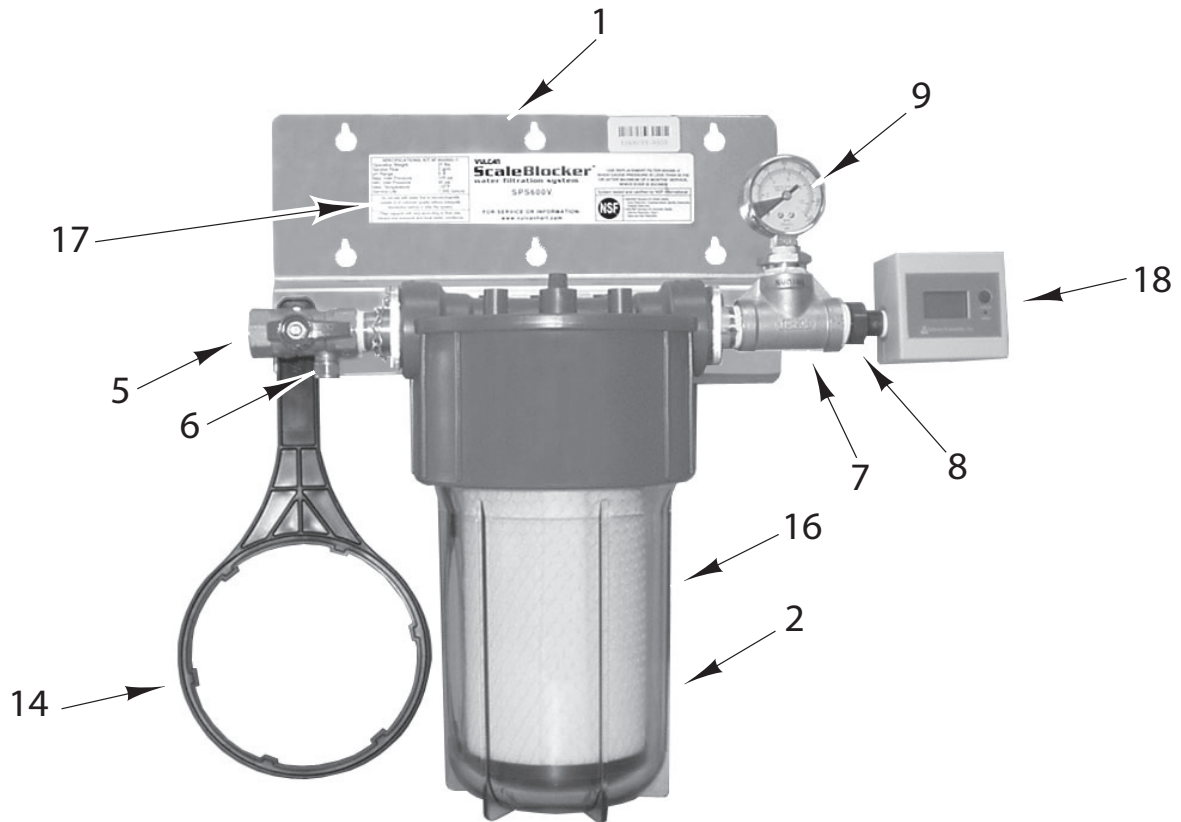

**REPLACEMENT PARTS LIST**  
**Model SPS600V**

PART NO.	NAME OF PART	AMT.
1	00-854306-00001 Backplate .....	1
2	00-854893-00005 Clear Housing, 10" (Feb. 2002 to Present) (6 Ribs) .....	1
	00-854306-00002 Clear Housing (Prior to Feb. 2002) (4 Ribs) .....	1
* 3	00-854306-00003 U-Bracket, Large .....	1
* 4	00-854893-00008 O-Ring, Large, Black (Feb. 2002 to Present) .....	1
	00-854306-00005 O-Ring, Large, Black (Prior to Feb. 2002) .....	1
5	00-854893-00024 Brass Ball Valve, 3/4" (Feb. 2002 to Present) .....	1
	00-223220-00003 Brass Ball Valve, 3/4" (Prior to Feb. 2002) .....	1
6	00-854893-00012 3/8" Tubing Connector (Feb. 2002 to Present) .....	1
7	FP-069-02 Tee Pipe Fitting, Stainless Steel, Internal Threads, 3/4" .....	1
8	FP-081-25 Pipe Bushing, Stainless Steel, 3/4" x 1/4" .....	1
9	00-854306-00009 Brass Pressure Gauge .....	1
* 10	FP-041-54 Nipple, Brass, 3/4" x 2 (Feb. 2002 to Present) .....	1
* 11	FP-054-29 Nipple, Stainless Steel, 3/4" x 2 (Feb. 2002 to Present) .....	1
* 12	00-854893-00025 Reducer, Plastic, 3/4" to 3/8" (Feb. 2002 to Present) .....	1
* 13	00-854893-00026 Nipple, Plastic, 3/8" x 1 1/2" (Feb. 2002 to Present) .....	1
14	00-854893-00022 Wrench (10") for Housing (Feb. 2002 to Present) .....	1
	00-854306-00018 Wrench (10") for Housing (Prior to Feb. 2002) .....	1
* 15	00-854306-00019 4-IN-1 City Water Check + Test Strip .....	1
16	00-854893-00003 Filter Mounting Head, Red (Feb. 2002 to Present) .....	1
	00-854306-00020 Filter Mounting Head, Red (Prior to Feb. 2002) .....	1
	00-854893-00028 Dip Tube, 10" .....	1
17	00-854893-00020 Label, Backplate, SPS600V (Feb. 2002 to Present) .....	1
18	00-854893-00011 Water Flow Meter (Feb. 2002 to Present) .....	1
19	00-854893-00013 ScaleBlocker Release Agent .....	1
20	00-854306-00004 ScaleBlocker PM Kit, 10" (Complete) .....	1
	ScaleBlocker 10" PM Kit Contains:	
	White Filter Cartridge, 10" .....	1
	Flat Washer, Small White (Bottom) .....	1
	Flat Washer, Small White (Top) .....	1
	ScaleBlocker Release (1 lb. Bag) .....	2
	10" Dip Tube .....	1
	4-IN-1 City Water Check + Test Strip .....	1
	Filter Registration Card .....	1
	Water Filter Cartridge Replacement Instructions .....	1
* Not Shown		

**REPLACEMENT PARTS LIST**  
**Model SPS620V**

PART NO.	NAME OF PART	AMT.
1	00-854306-00001 Backplate .....	1
2	00-854893-00007 Clear Housing, 20" (Feb. 2002 to Present) (6 Ribs) .....	1
	00-854306-00012 Clear Housing, 20" (Prior to Feb. 2002) (4 Ribs) .....	1
* 3	00-854306-00003 U-Bracket, Large .....	1
* 4	00-854893-00008 O-Ring, Large, Black (Feb. 2002 to Present) .....	1
	00-854306-00005 O-Ring, Large, Black (Prior to Feb. 2002) .....	1
5	00-854893-00024 Brass Ball Valve, 3/4" (Feb. 2002 to Present) .....	1
	00-223220-00003 Brass Ball Valve, 3/4" (Prior to Feb. 2002) .....	1
6	00-854893-00012 3/8" Tubing Connector (Feb. 2002 to Present) .....	1
7	FP-069-02 Tee Pipe Fitting, Stainless Steel, Internal Threads, 3/4" .....	1
8	FP-081-25 Pipe Bushing, Stainless Steel, 3/4" x 1/4" .....	1
9	00-854306-00009 Brass Pressure Gauge .....	1
* 10	FP-041-54 Nipple, Brass, 3/4" x 2 (Feb. 2002 to Present) .....	1
* 11	FP-054-29 Nipple, Stainless Steel, 3/4" x 2 (Feb. 2002 to Present) .....	1
* 12	00-854893-00025 Reducer, Plastic, 3/4" to 3/8" (Feb. 2002 to Present) .....	1
* 13	00-854893-00026 Nipple, Plastic, 3/8" x 1 1/2" (Feb. 2002 to Present) .....	1
14	00-854893-00023 Wrench (20") for Housing (Feb. 2002 to Present) .....	1
	00-854306-00018 Wrench (20") for Housing (Prior to Feb. 2002) .....	1
* 15	00-854306-00019 4-IN-1 City Water Check + Test Strip .....	1
16	00-854893-00003 Filter Mounting Head, Red (Feb. 2002 to Present) .....	1
	00-854306-00020 Filter Mounting Head, Red (Prior to Feb. 2002) .....	1
17	00-854893-00021 Label, Backplate, SPS620V .....	1
18	00-854893-00011 Water Flow Meter (Feb. 2002 to Present) .....	1
19	00-854893-00013 ScaleBlocker Release Agent .....	1
20	00-854306-00013 ScaleBlocker PM Kit, 20" .....	1
	ScaleBlocker 20" PM Kit Contains:	
	White Filter Cartridge, 20" .....	1
	Flat Washer, Small White (Bottom) .....	1
	Flat Washer, Small White (Top) .....	1
	ScaleBlocker Release (1 lb. Bag) .....	2
	20" Dip Tube .....	1
	4-IN-1 City Water Check + Test Strip .....	1
	Filter Registration Card .....	1
	Water Filter Cartridge Replacement Instructions .....	1

\* Not Shown