

**WIRING DIAGRAM**

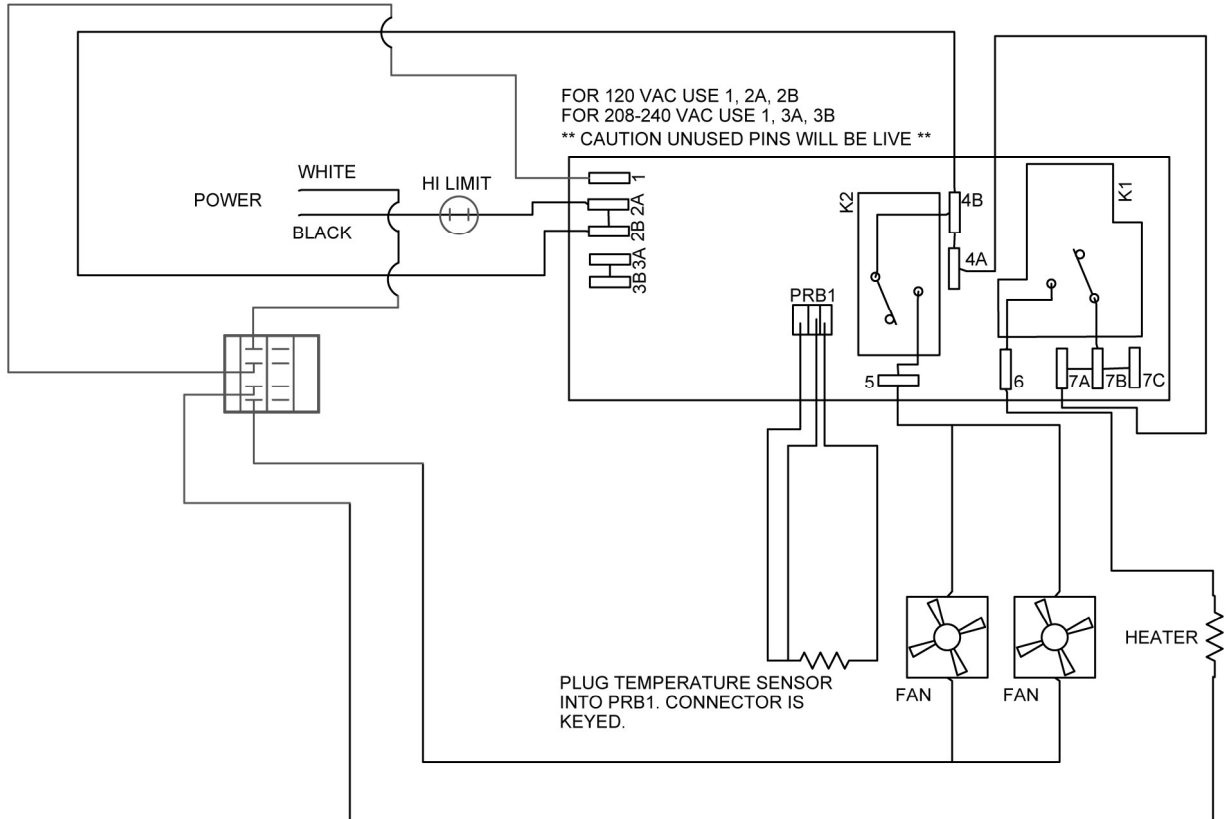

DERIVED FROM VBP/VPT ELECTRONIC CONTROL

AI4919

**ROTARY CONTROLS**

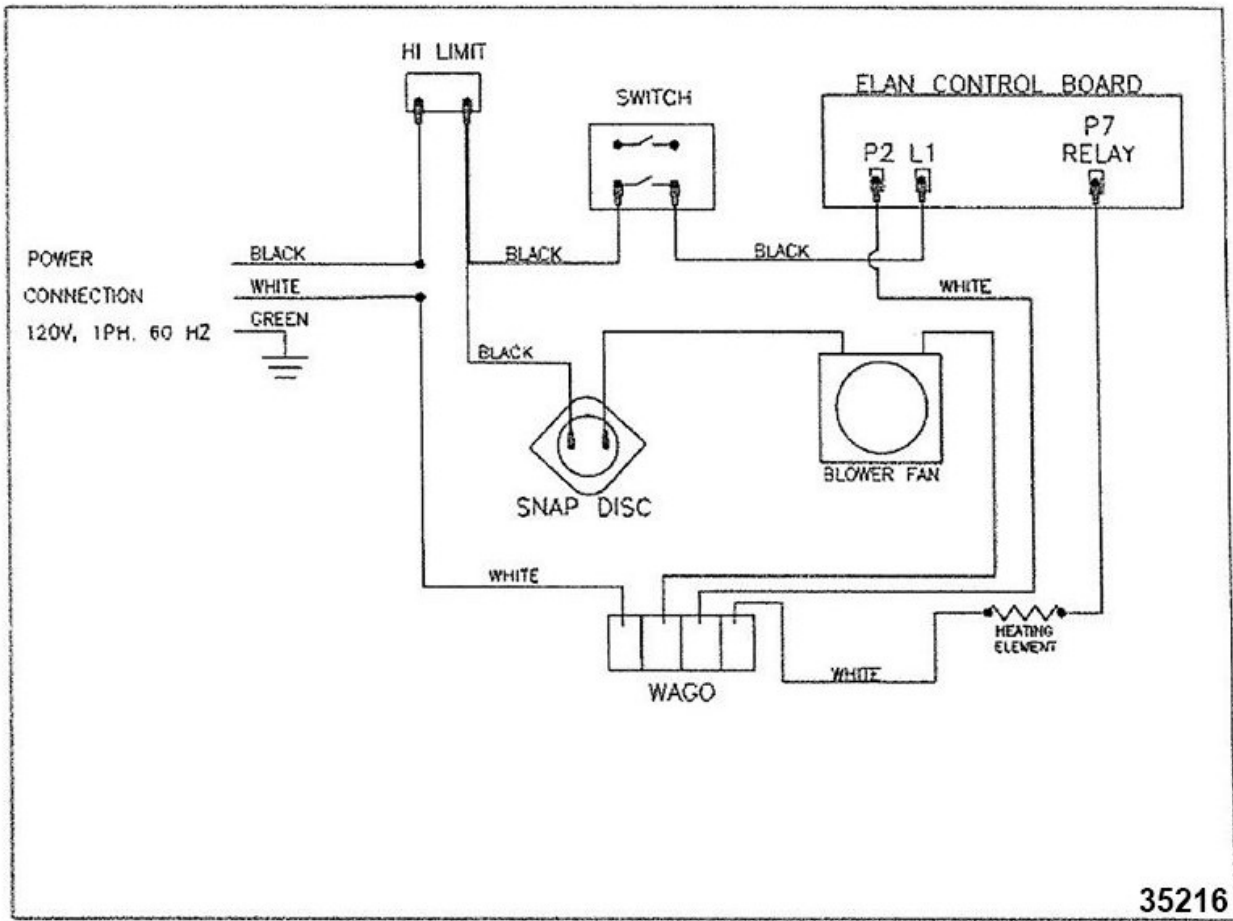

**TOUCH CONTROLS**

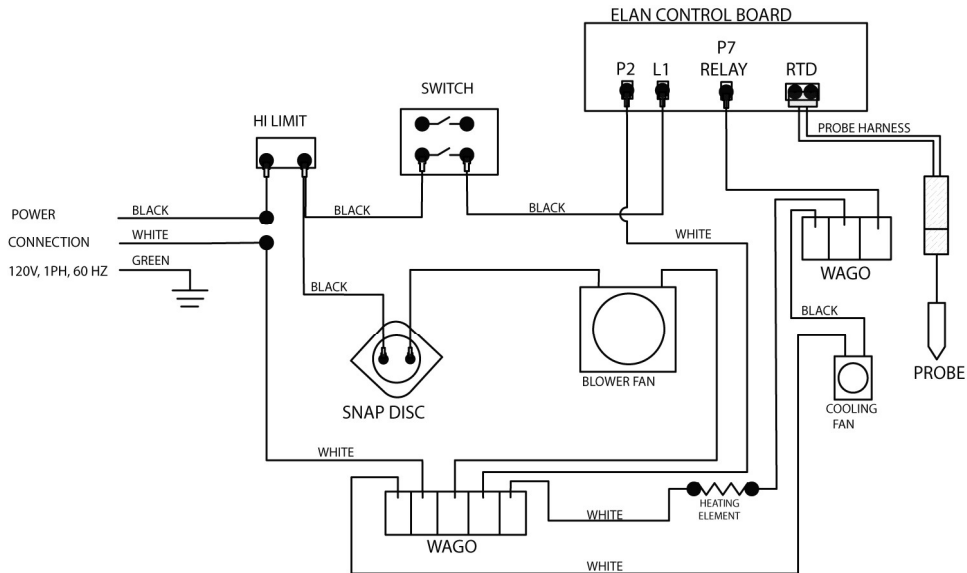

VBP and VPT ES Models

DERIVED FROM ELAM VBP ES REV B

AI5331

Production Start 1/10/2022

**SEQUENCE OF OPERATION**

1. Conditions.

- A. Unit connected to correct voltage and is properly grounded.
- B. Power switch is off.