

VULCAN[®]

**INSTALLATION, OPERATING, SERVICE
AND PARTS MANUAL FOR
ELECTRIC COUNTER TILTING
2/3 JACKETED KETTLES
VEC SERIES**



VEC6

Shown with stand and drain pan

Vulcan service agencies are located throughout the United States.
For location and phone number of one near you, call your local Vulcan dealer.

VULCAN-HART CORPORATION, P.O. BOX 696, LOUISVILLE, KY 40201-0696, TEL. (502) 778-2791
TECHNICAL ASSISTANCE (800) 626-2700

IMPORTANT

OPERATING, INSTALLING AND SERVICE PERSONNEL

The operating information on this equipment has been prepared for use by qualified and/or authorized operating personnel.

All installation and service on this equipment is to be performed by qualified, certified, licensed and/or authorized installation or service personnel, with the exception of any part marked with a in front of the part number.

To obtain the name and location of an authorized Vulcan service agency, contact your Food Service Equipment dealer by calling 1-800-626-2700.

DEFINITIONS

QUALIFIED AND/OR AUTHORIZED OPERATING PERSONNEL

Qualified or authorized operating personnel are those who have carefully read the information in this manual and are familiar with the equipment's functions or have had previous experience with the operation of the equipment covered in this manual.

1. For the installation of gas piping from the outlet side of the gas meter, or the service regulator when the meter is not provided, and the connection and installation of the gas appliance, qualified installation personnel must be experienced in such work, be familiar with all precautions required, and have complied with all requirements of state or local authorities having jurisdiction. In the absence of local codes, installation must comply with National Fuel Gas Code ANSI Z223.1-latest edition.
2. For the installation of electrical wiring from the electric meter, main control box or service outlet to the electric appliance, qualified installation personnel must be experienced in such work, be familiar with all precautions required, and have complied with all requirements of state or local authorities having jurisdiction. In the absence of local codes, installation must comply with the National Electrical Code ANSI NFPA No. 70 latest edition.
3. For the installation of steam piping from the source of supply to the service inlet of the appliance, qualified installation personnel must be experienced in such work, be familiar with all precautions required, and have complied with all requirements of state or local authorities having jurisdiction.

QUALIFIED SERVICE PERSONNEL

Qualified service personnel are those who are familiar with this equipment who have been endorsed by our company. All authorized service personnel are required to be equipped with a complete set of service and parts manuals and stock a minimum amount of parts for this equipment.

SHIPPING DAMAGE CLAIM PROCEDURE

For your protection, please note that equipment in this shipment was carefully inspected and packed by skilled personnel before leaving the factory. The transportation company assumes full responsibility for safe delivery upon acceptance of this shipment.

If shipment arrives damaged:

1. **VISIBLE LOSS OR DAMAGE** — Be certain this is noted on freight bill or express receipt and signed by person making delivery.
2. **FILE CLAIM FOR DAMAGES IMMEDIATELY** — Regardless of extent of damage.
3. **CONCEALED LOSS OR DAMAGE** — If damage is unnoticed until merchandise is unpacked, notify transportation company or carrier immediately, and file "concealed damage" claim with them. This must be done within fifteen (15) days of the date the delivery is made to you. Be sure to retain container for inspection.

We cannot assume responsibility for damage or loss incurred in transit. We will, however, be glad to furnish you with necessary documents to support your claim.

PLEASE RETAIN THIS MANUAL FOR FUTURE REFERENCE

INDEX

Your Vulcan Steam Jacketed Electric Kettle is produced with quality workmanship and material. Proper installation, usage and maintenance will result in many years of satisfactory performance.

The manufacturer suggests that you thoroughly read

this entire manual and carefully follow all of the instructions provided. Retain this manual for future reference.

A data plate stating the unit model number, serial number, and electrical supply that the unit requires is located on the lower right outside corner of the control box.

DESCRIPTION

PAGE

DEFINITIONS OF PERSONNEL (OPERATING, INSTALLATION and SERVICE) AND SHIPPING		
DAMAGE CLAIM PROCEDURE		(Inside Front Cover)
INDEX		3
DESCRIPTION		4
CAPACITIES		4
ELECTRICAL CHARACTERISTICS		4
INSTALLATION		5-6
CLEANING		6
OPERATION		7
SERVICE		8
TROUBLESHOOTING		9
PARTS: EXTERIOR AND COMPONENTS		10-11
WIRING DIAGRAMS:		
	MODEL VEC6: 208 VOLTS	12
	MODEL VEC6: 208/380 VOLTS	13
	MODEL VEC6: 240 VOLTS	14
	MODEL VEC6: 240/415 VOLTS	15
	MODEL VEC10: 208 VOLTS	16
	MODEL VEC10: 220/380 VOLTS	17
	MODEL VEC10: 240 VOLTS	18
	MODEL VEC10: 240/415 VOLTS	19
	MODEL VEC10: 480 VOLTS	20
	MODEL VEC20: 208 VOLTS	21
	MODEL VEC20: 230 VOLTS	22
	MODEL VEC20: 240 VOLTS	23

DESCRIPTION

The Vulcan self-generating electric kettles in this manual are pressure vessels of double wall stainless steel construction forming a sealed jacket around the lower two thirds of the kettle.

The kettle bowl is the container for the food product which ideally should be a liquid or semi-liquid for complete contact with the bowl surface to fully absorb the heat transmitted through the surface from the pressurized steam generated in the kettle jacket.

The jacket functions as a self-contained sealed reservoir with a permanent solution of water and anti-freeze, deep enough to immerse and protect the replaceable electric heating elements. Included is a low water electric cut off. The water is the source of the steam.

The heating elements are controlled to provide the dialed temperatures throughout the range from slow simmer to rolling boil. Settings from "1" to "10" are jacket temperatures of 90° to 300° F (32° to 149°C).

The VEC6 and VEC10 tilting kettles are to be permanently mounted on a counter or a stand. The VEC20 is to be floor mounted on 6" legs.

Each kettle is equipped with a relief valve. Options include a lift off stainless steel lid covering the kettle bowl. Another option is either a single or a double faucet with a swing spout. On the VEC20 an available option is a stainless steel tangent draw off valve to remove the food product from the kettle.

CAPACITIES

The three models end with 6, 10, or 20 to indicate the capacity of each kettle in gallons. The VEC6 has a capacity of 6 gallons. A VEC10, 10 gallons, and 20 in the VEC20.

ELECTRICAL CHARACTERISTICS

Model	PH	208V		230V		240V		380V		415V		480V	
		KW	AMP	KW	AMP	KW	AMP	KW	AMP	KW	AMP	KW	AMP
VEC6	1	7.5	36.0	7.5	32.6	7.5	31.2						
	3	7.5	20.8	7.5	18.8	7.5	18.6	7.5	11.4	7.5	10.4		
VEC10	1	12.0	57.6	12.0	52.2	12.0	50.0						
	3	12.0	33.3	12.0	30.1	12.0	28.9	12.0	18.2	12.0	16.7	12.0	14.4
VEC20	1	12.0	57.6	12.0	52.2	12.0	50.0						
	3	12.0	33.3	12.0	30.1	12.0	28.9	12.0	18.2	12.0	16.7	12.0	14.4

INSTALLATION

WARNING: Electrical and grounding connections must comply with applicable portions of the National Electrical Code and/or other local electrical codes.

- A. Position the VEC6 or VEC10 kettle on the counter or the stand, allowing sufficient rear clearance from the wall to allow the kettle to tilt completely without obstruction. The VEC20 is floor mounted.
- B. Mark the four corner locations of the kettle base as shown below.

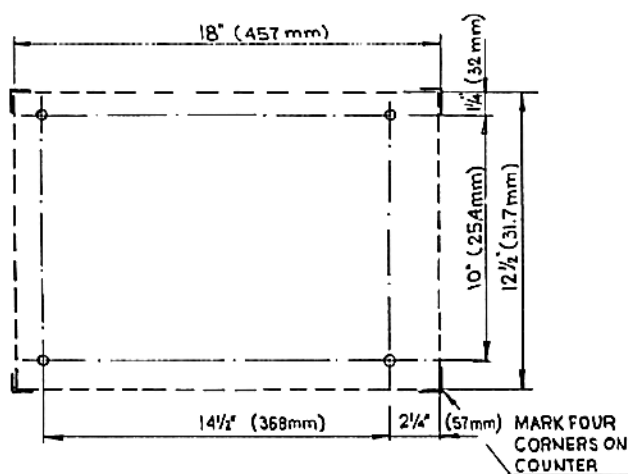

FRONT OF THE KETTLE

- C. Remove the kettle from the counter and locate the positions of the 4 holes as noted on the above drawing. Drill four 7/16" diameter holes in the counter.
- D. Apply a continuous bead of high grade NSF listed sealant along the complete outer edges of the kettle base.
- E. Use 5/16-18 x 1 1/2" Hex Cap Screws (not supplied) with suitable flat washers (not supplied) to bolt the unit down. When the unit is ordered with a stand, six lugs are furnished to bolt the unit to stand.

- F. Wipe off any excess sealant.
- G. A control box with power supply the same as the electrical rating of the kettle should be located nearby.
- H. A waterproof electrical connection for the power supply to the console housing must be provided.
- I. Ground the kettle to the terminal provided inside the console housing.
- J. Turn the power ON and check the unit for proper operation.

INSTALLING THE FLOOR MOUNTED VEC20

- A. Select a location to provide drainage directly below the draw off valve if this option is ordered. Allow sufficient rear clearance from the wall for the kettle to tilt freely without obstructions.
- B. Mark anchoring hole locations through the flanged rear feet.
- C. With hole locations marked, drill holes and insert expansion plugs to accommodate 5/16" size lag bolts.
- D. Reposition the kettle. Level the kettle by making necessary adjustments using the flanged feet.
- E. Bolt the kettle down and seal with a high grade sealing compound. Sealant must be applied not only to bolt heads but around the flanges and must be making contact with floor surface to meet NSF requirements. Wipe off excess sealant immediately.

INSTALLATION

Since air is not a good media to transfer heat, air has been removed from the kettle jacket during factory testing. The pressure gauge should indicate a vacuum in the jacket of approximately 25 to 30 inches of mercury when the kettle is cold or has been inoperative for some time. The kettle jacket is intended to operate as a completely sealed self-contained chamber and it is advisable not to trip the relief valve during inoperative periods since this will break the vacuum seal and allow air to enter the kettle jacket.

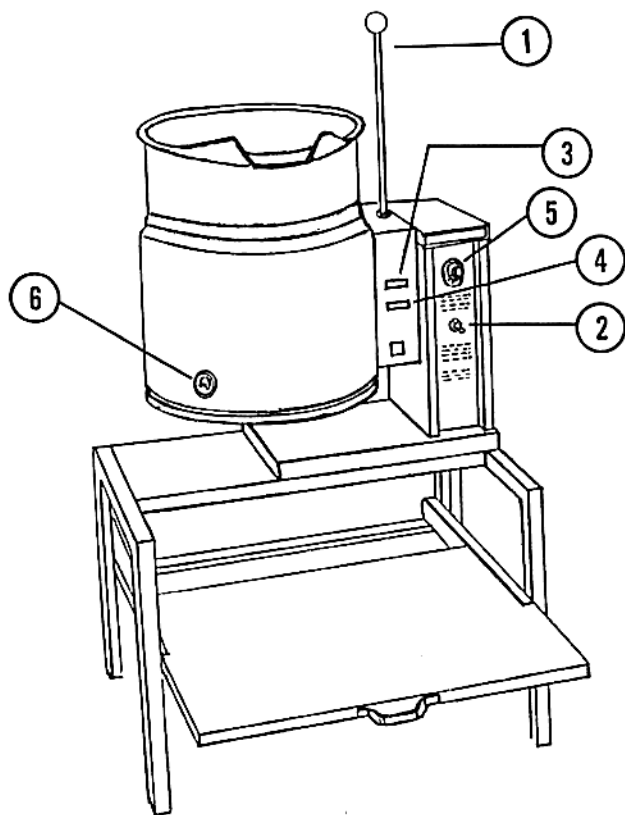

CONTROLS AND SIGNALS

The illustration shows the physical location of the controls, signals, and operating features.

ITEM 1: Tilting handle with insulating knob.

ITEM 2: Kettle power switch controls the power to the kettle.

ITEM 3: Low water indicator light. When lit, indicates insufficient water in the kettle jacket and the sensing probe has interrupted power supply to the controls and to the heating elements.

ITEM 4: Pilot light functions with the thermostat knob and when lit, indicates the heating elements are on.

ITEM 5: Thermostat knob allows the operator to select the kettle temperature in increments from "1" to "10", from low simmer to a rolling boil.

ITEM 6: Vacuum, pressure gauge indicates the vacuum in inches of mercury or pressure in pounds per square inch inside the kettle jacket.

CLEANING

WARNING: Do not hose down under any condition. Failure to comply will void the warranty.

The kettle interior and exterior should be thoroughly washed after each use when a different food is to be cooked next or when cooking is completed for the day. Before cleaning check that the kettle has cooled enough to touch it.

A. Add water and mild detergent to the kettle.

B. Scrub the kettle interior with a nylon brush.

NOTE: Never scrape the inside of the kettle with metal tools, steel scouring pads, or abrasive cleaners. Scratches will result which will spoil the kettle's general appearance and make it harder to clean it completely.

C. Loosen food which is stuck to the kettle bowl by allowing the food to soak at a low temperature setting.

D. Rinse with clear water and wipe dry.

E. Wipe the exterior, rinse and dry.

OPERATION

SEQUENCE OF OPERATION

If the pressure in the jacket reaches the rated pressure of the kettle, the relief valve will open automatically and release excessive steam pressure.

Self-contained kettles generate steam in the kettle reservoir. The sequence of operation is:

- A. The operator turns the power switch to the ON position and sets the temperature control dial at the desired setting between "1" to "10", 90° F to 300°F (32°C to 149°C) jacket temperature.
- B. The control circuit is completed to the temperature controller if these conditions are in place:
 1. The water level in the kettle reservoir is deep enough to keep the low water electric shut off circuit closed. A shut off is indicated when the amber low water light turns on, showing that the heating element has shut off.

2. The kettle is in a vertical position with the circuit completed through the tilt interlock switch.
- C. The temperature control contacts are closed and energizing the contactor coils.
- D. Power is being supplied to the elements through the closed power contactors.
- E. As the temperature of the water rises in the kettle reservoir, an increase in steam pressure is shown on the pressure gauge.
- F. When the temperature of the steam in the reservoir reaches the setting dialed on the temperature control dial, the temperature controller will open the contacts and shut off the heating element. On/off cycles will continue to maintain temperature control.

OPERATING PROCEDURES

WARNING: The kettle is hot. Use care when operating and servicing the kettle.

- A. Check that the disconnect switch is on.
- B. Check the pressure gauge for a correct cold kettle reading. The vacuum should be 25-30 in.Hg (84-100k/Pa). If the reading is not low enough, follow VENTING procedure before using the kettle.
- C. Turn the console power switch to the ON position.
- D. Preheat the kettle by placing the thermostat knob at "10" and wait until the TEMPERATURE light cycles off.

NOTE: Food products with milk or egg base should be placed into a cold kettle and then the cooking operation begun. Avoid sudden contact of these food products to a hot kettle surface because the food will stick to the surface.

- E. Pour the food to be cooked into the kettle.
- F. Place the thermostat knob at the required temperature setting, shown in next column, from "4" to "10" paralleling a temperature range from roughly 90°F to 300°F (32°C to 149°C) in the reservoir. The approximate temperatures with only water in the kettle bowl are as follows for various thermostat settings:

THERMOSTAT SETTING	APPROXIMATE TEMPERATURE (WATER)	
	F°	C°
4	90°	32°
5	125°	52°
6	160°	71°
7	195°	91°
8	231°	110°
9	273°	134°
10	300°	149°

- G. When the cooking is finished, set the thermostat knob and the power switch to their OFF positions.
- H. Pour the finished product from the kettle using the tilt handle. Be careful to avoid splashing, the food can be hot.
- I. Add water to the kettle to clean it when next cooking a different product or cooking is completed.
- J. Wash the kettle thoroughly. See CLEANING procedure.

The temperature required for the cooking process to function must be greater than the boiling point of the liquid food product, that is, water. The higher the temperature, the greater the steam pressure in the jacket and the quicker the cooking process. For example, steam pressurized at 30 p.s.i. reaches a temperature of 274°F.

SERVICE

MAINTENANCE

No general maintenance is required other than following the cleaning procedures.

LOW WATER LEVEL

Proper water level must be maintained within the jacket for the kettle to operate. Depletion of water may occur from excessive opening of, or leakage through, the relief valve.

VENTING

Check the vacuum/pressure gauge when the kettle is cold. The gauge should be in the vacuum zone measuring between 25-30 in.Hg (84-100k/Pa). If not, air is in the jacket which must be removed for proper heating. Use the following procedures to vent the air.

- Place the power switch in the ON position with the kettle empty.
- Set the temperature control thermostat to "10". Heat the kettle until the heat indicator light goes off.
- Using a $\frac{7}{16}$ " wrench, open the bleed vent one full turn, hold for 10 seconds and then close the vent.
- Let the kettle cool. Check for a correct vacuum of 25-30 in.Hg (84-100k/Pa). If reading is not low enough, repeat the venting procedure A through C.

- Bleed Vent
- Pressure Relief Valve

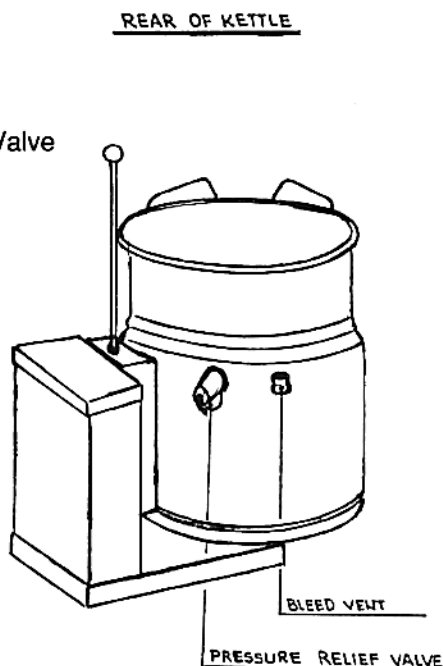

FILLING THE JACKET RESERVOIR

The reservoir water level must be maintained high enough to submerge the heating elements. If the low water light turns on during use, the water level is not adequate and the low water control has automatically shut off the heating elements.

CAUTION: BEFORE ADDING WATER TO THE RESERVOIR, THE WATER SUPPLY SHOULD BE ANALYZED TO ENSURE THAT HARDNESS IS NO GREATER THAN 2.0 GRAINS PER GALLON AND THE pH LEVEL IS WITHIN THE RANGE OF 7.0-8.5. WATER WHICH FAILS TO MEET THESE STANDARDS SHOULD BE TREATED, OR USE IONIZED DISTILLED WATER WITH SODIUM. EQUIPMENT FAILURE CAUSED BY INADEQUATE WATER QUALITY IS NOT COVERED UNDER WARRANTY.

Use the following procedure to fill the reservoir.

- Set the thermostat and power switch to OFF position.
- Remove the $\frac{7}{16}$ " vent fitting from the bleed vent on the back of kettle. This removes any pressure in the kettle. Insert a funnel into the vent opening and add 3 or 4 ounces of water. Turn the unit back on. If the low water light turns on, turn the unit off and add another 3 or 4 ounces of water. Turn on the unit. If the light comes on you still need to add water until the elements are covered and the low water light stays off. Then turn the unit off and add the following amount of water as indicated by the model number. This amount "fills" the jacket reservoir to its correct operating water height. For a 6 gallon model, add 50 ounces (1.5 liters). For 10 gallon models, add 100 ounces (3 liters). For the 20 gallon model, add 140 ounces (4.2 liters).
- Replace the vent fitting and tighten it.
- With the kettle in the upright position, the low water light should be off at this time. If so, follow the venting procedure to vent air from reservoir (see VENTING). If the low water light is not off, repeat the section on filling the jacket reservoir.

TROUBLESHOOTING

EXTREMELY SLOW COOKING TIME

If the cooking time is abnormally slow, then the problem may be due to air being present in the kettle jacket. To remove the air, follow VENTING instructions. If this problem persists and kettle will not reach and maintain the pressure gauge zone of 20 to 25 vacuum when cold, then assume that a slow leak in the jacket may be responsible. Check all fitting connections to jacket and also the element gasket. Tighten or replace, if necessary.

Slow cooking time may be due to a burned out heating element. Test the elements and if defective, replace the element assembly.

KETTLE WILL NOT OPERATE WHEN TURNED ON

Kettle will not operate if the water level is inadequate in the jacket. See LOW WATER LEVEL instructions.

Initially, when the thermostat knob is dialed and the TEMPERATURE indicator light does not come on, then it may be assumed that the malfunction is due to either a defective thermostat or a loose wiring connection. If TEMPERATURE light comes on when thermostat knob is dialed fully (a setting of "10"), then eventually the kettle should reach its maximum temperature (280°F) in the jacket and a corresponding pressure reading of approximately 40 p.s.i. should register on the pressure gauge (on kettles rated at 50 p.s.i.).

Finally, when the kettle is turned "ON" and the thermostat knob is dialed, check that the contactors are being energized and power is available to the heating elements. Replace defective contactor(s).

PARTS LIST: EXTERIOR AND COMPONENTS

Orders for replacement parts should be sent to the nearest Vulcan parts depot.

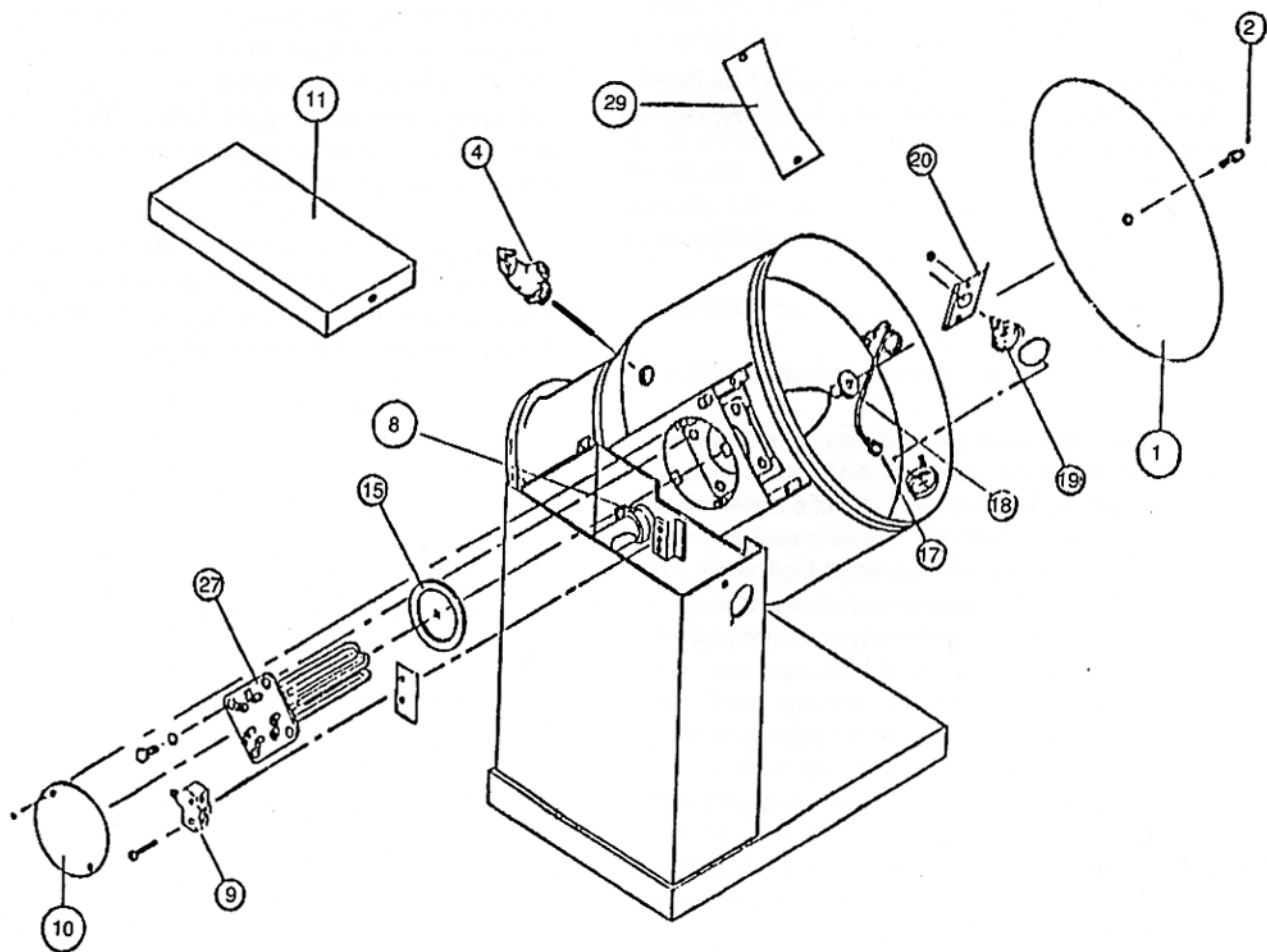

PARTS LIST: KETTLE EXTERIOR AND COMPONENTS (CONT.)

INDEX NO.	PART NUMBER	DESCRIPTION
1	840468	Cover, Kettle Enclosure VEC6
	840469	Cover, Kettle Enclosure VEC10
2	SC-041-09	Bolt, Enclosure Cover
3 *	881961	Air Vent 7/16", Assy.
4	881980	Valve, Relief (50 p.s.i.)
5 *	840470	Handle, Tilt
6 *	836964	Knob, Handle, Tilt
7 *	881970	Switch, Power
8	840471	Collar, Retaining
9	881971	Switch, Interlock
10	840472	Cover, Access, Element
11	840473	Cover, Box, Control
12 *	881960	Liquid Level Control
13 *	881975	Contactora
14 *	881985	Section, Terminal Block End, Terminal Block
15	840501	Gasket VEC6 Element
	881969	Gasket VEC10 Element
16 *	881981	Probe
17	FP-086-36	Connector 1/4 x 1/4
18	881058	Tube, Copper VEC6, 19" Long
	881058	Tube, Copper VEC10, 22" Long
19	881979	Gauge, Pressure
20	836938	Plate, Mounting
21 *	881995	Knob Thermostat
22 *	881993	Controller, Temperature (thermostat)
23 *	840502	Potentiometer, Remote
24 *	881994	Sensor, Temperature
25 *	881972	Light, Low Water
26 *	881972	Light, Temperature
27		Elements Heating VEC6
	881986	208V, 7.5KW
	881989	220V or 380V 7.5KW
	881988	240V or 415V 7.5KW
	881990	480V 7.5KW
		Elements Heating VEC10
	881996	208V 12KW
	881998	240V, or 415 12KW
	881997	220V/380V 12KW
	881999	480V 12KW
28	* *	Panel, Control
29	840475	Cover, Box, Trunnion VEC10
	840476	Cover, Box, Trunnion VEC6

* Not shown in exploded view

* * Consult Factory.

WIRING DIAGRAM: MODEL VEC6: 208 VOLTS

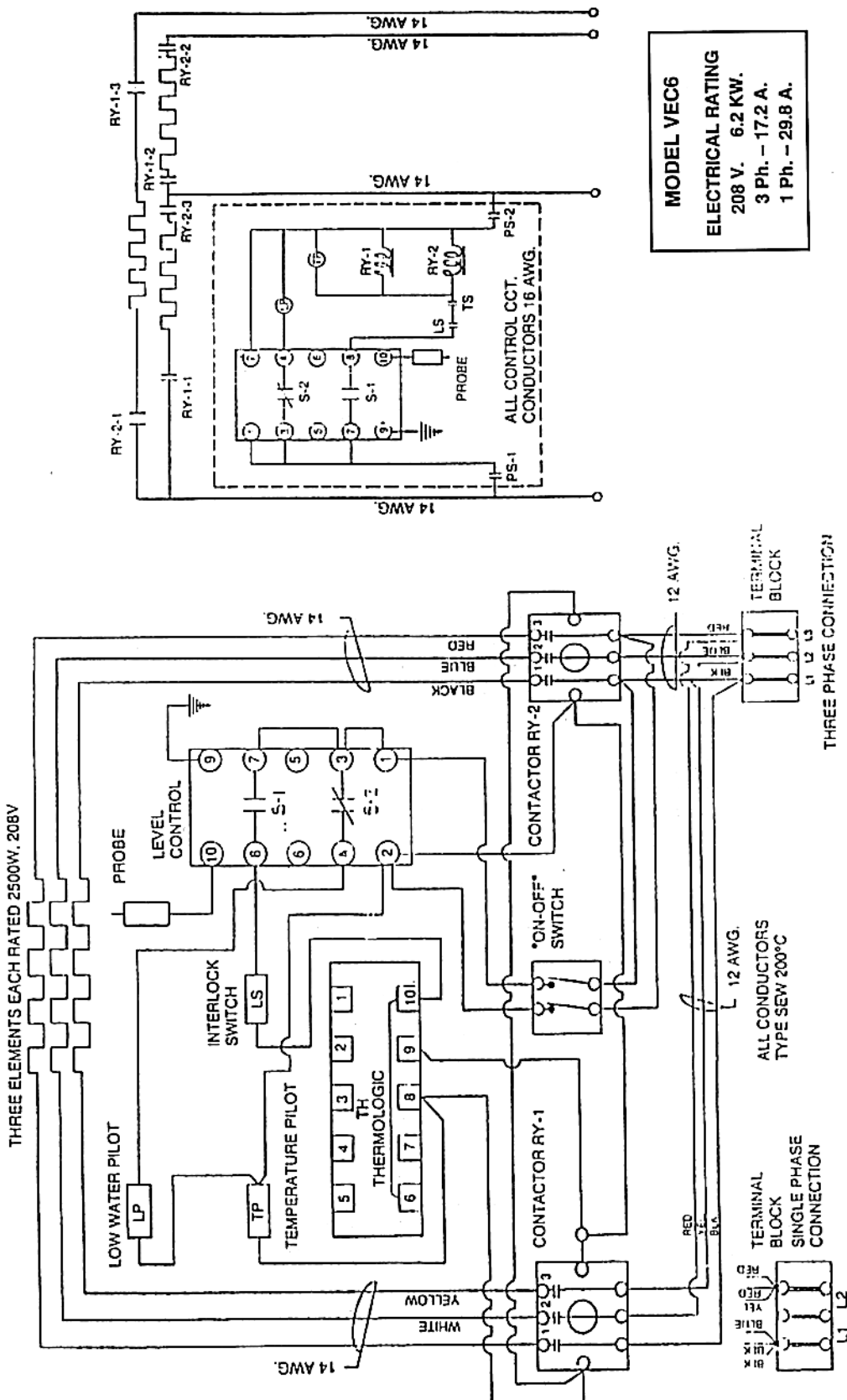

WIRING DIAGRAM: MODEL VEC6: 208/380 VOLTS

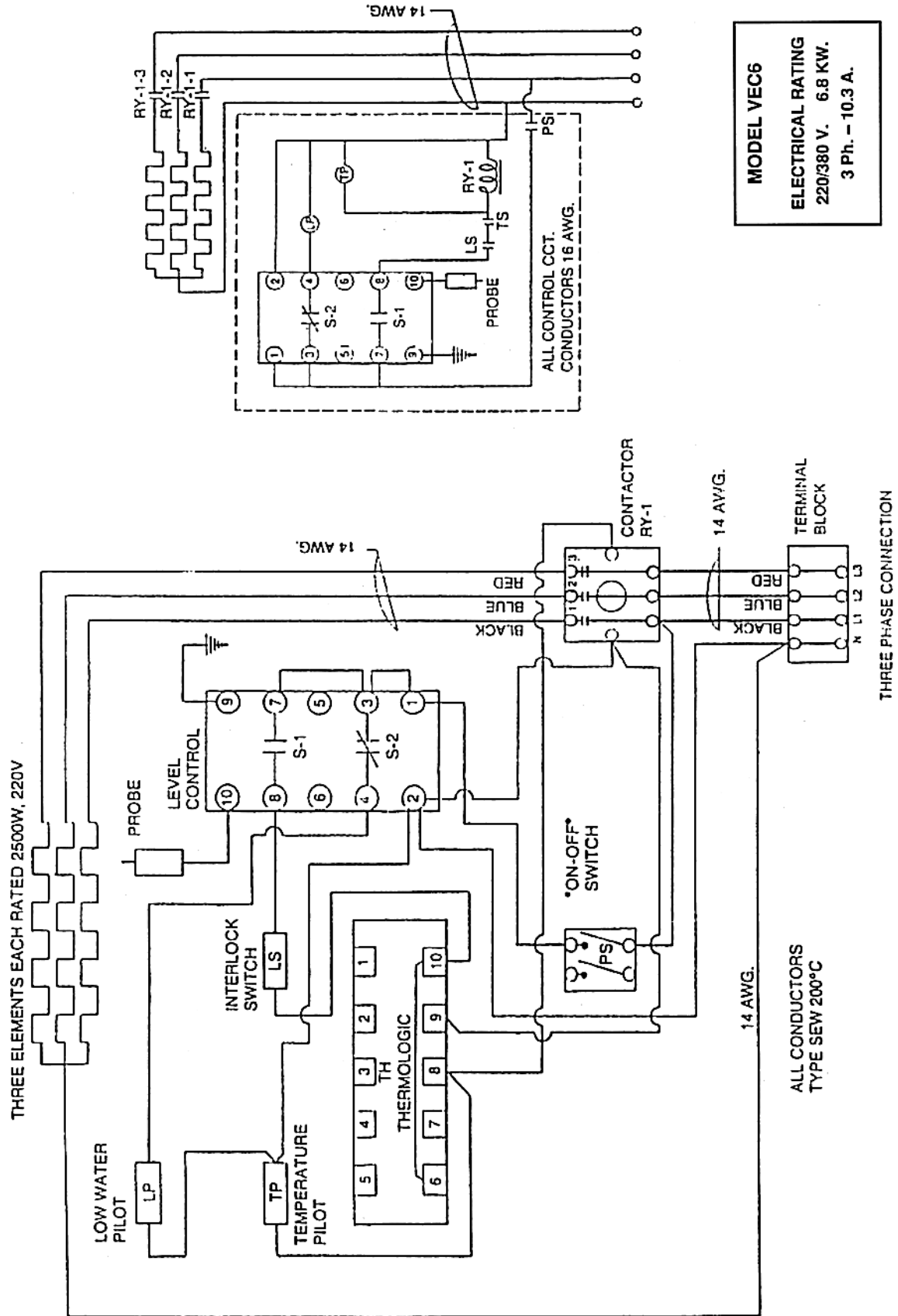

MODEL VEC6
ELECTRICAL RATING
 220/380 V. 6.8 KW.
 3 Ph. - 10.3 A.

ALL CONDUCTORS
 TYPE SEW 200°C

THREE PHASE CONNECTION

WIRING DIAGRAM: MODEL VEC6: 240 VOLTS

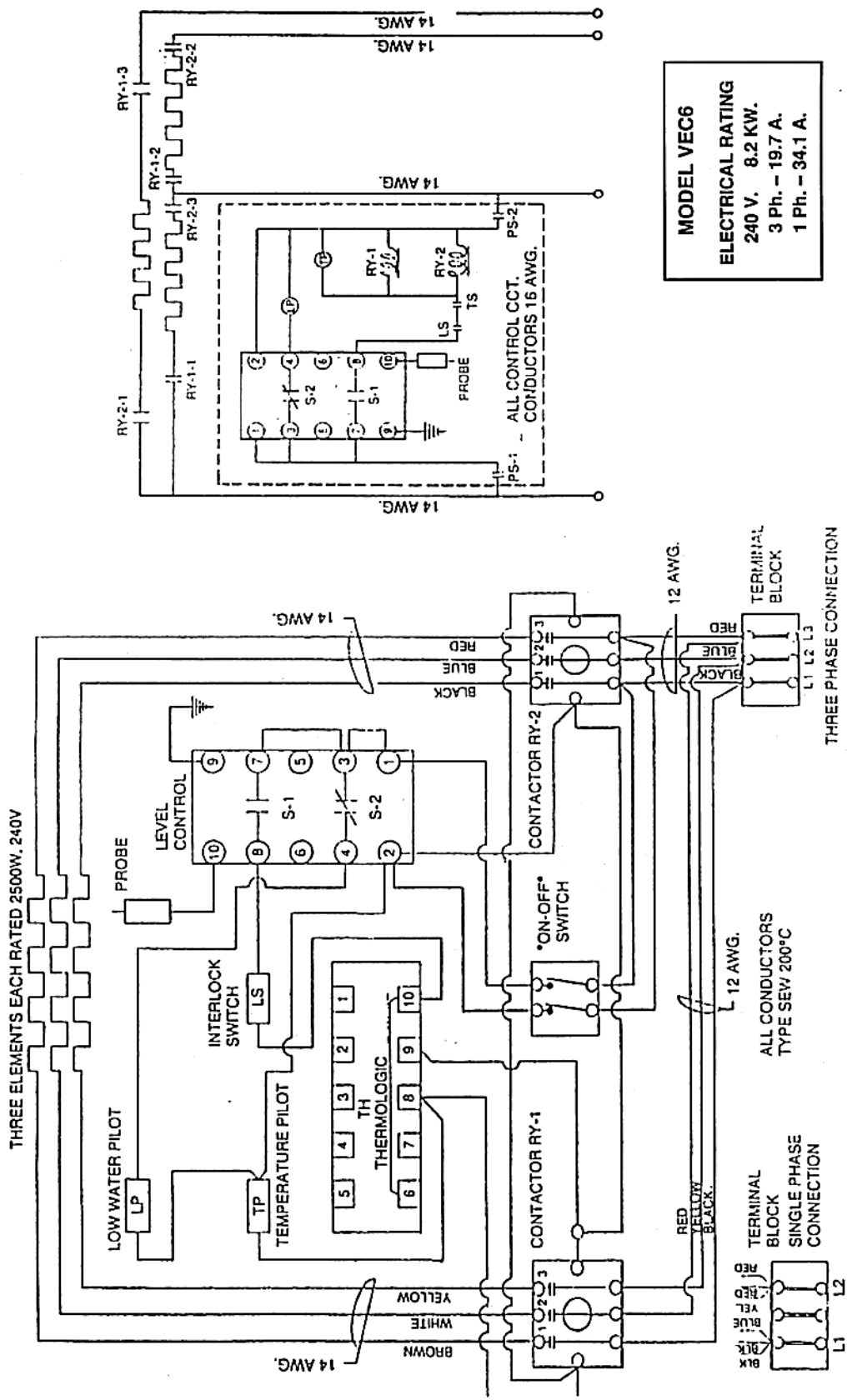

MODEL VEC6
ELECTRICAL RATING
 240 V, 8.2 KW.
 3 Ph. - 19.7 A.
 1 Ph. - 34.1 A.

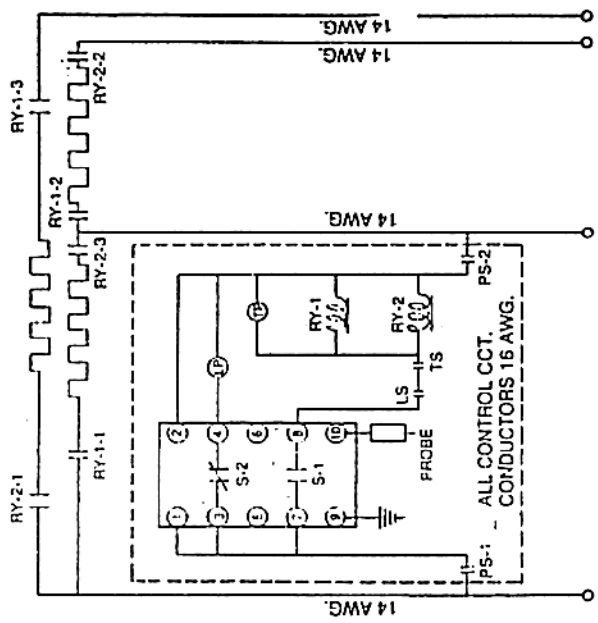

WIRING DIAGRAM: MODEL VEC6: 240/415 VOLTS

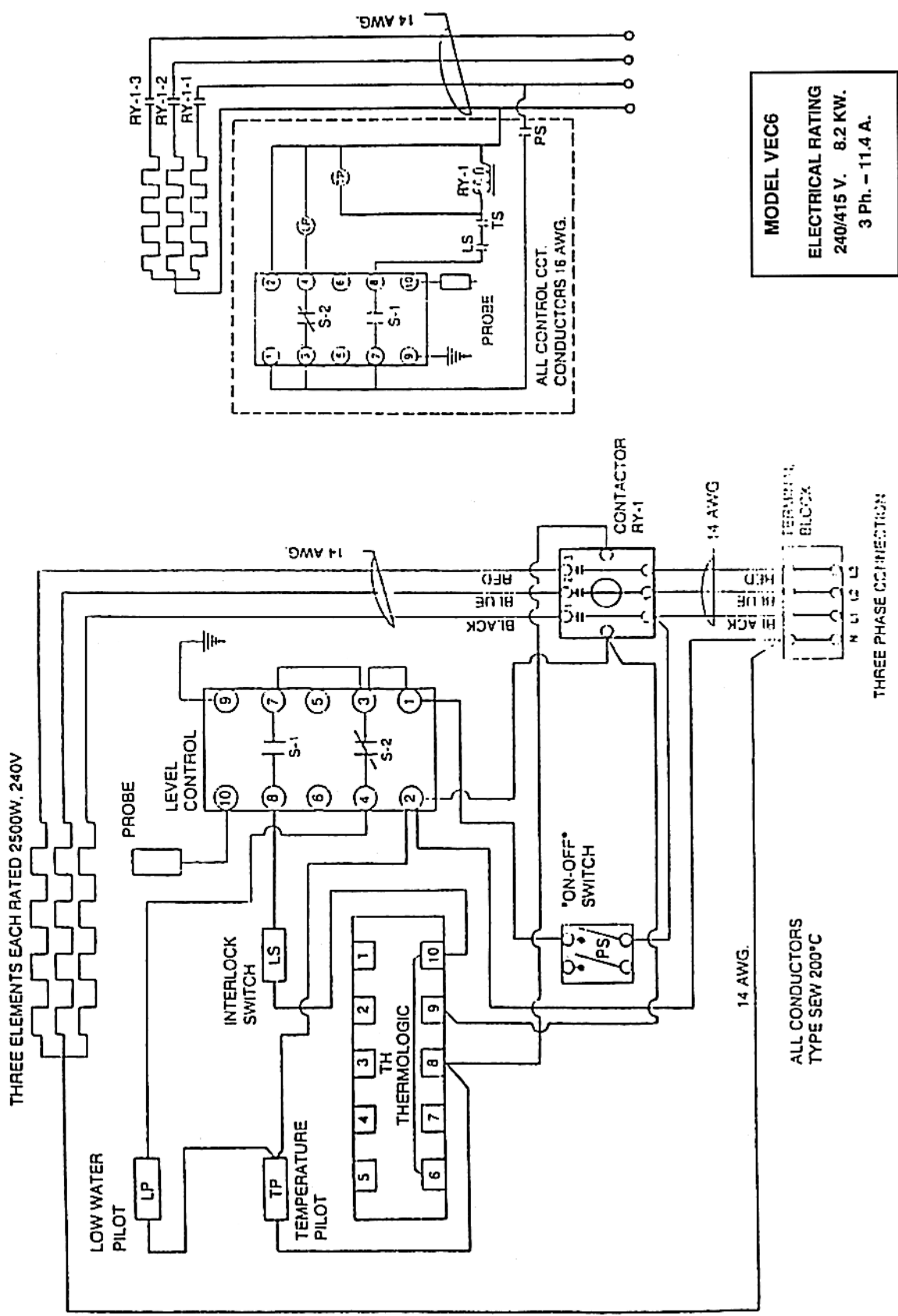

WIRING DIAGRAM: MODEL VEC10: 240 VOLTS

THREE ELEMENTS EACH RATED 4000W, 240V

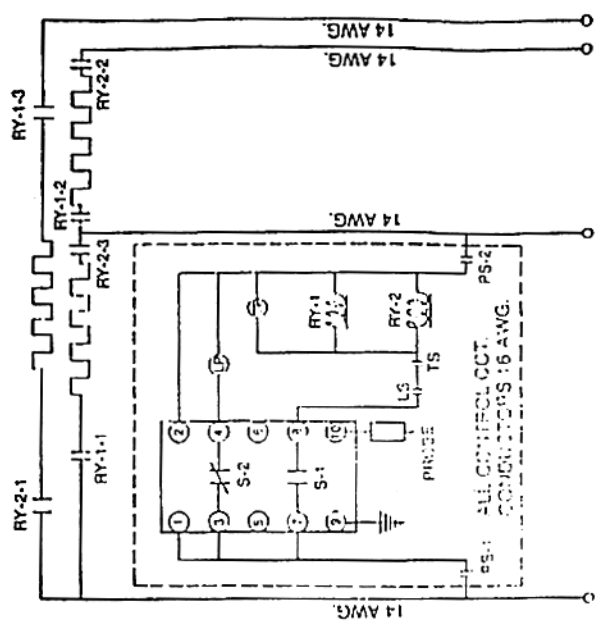
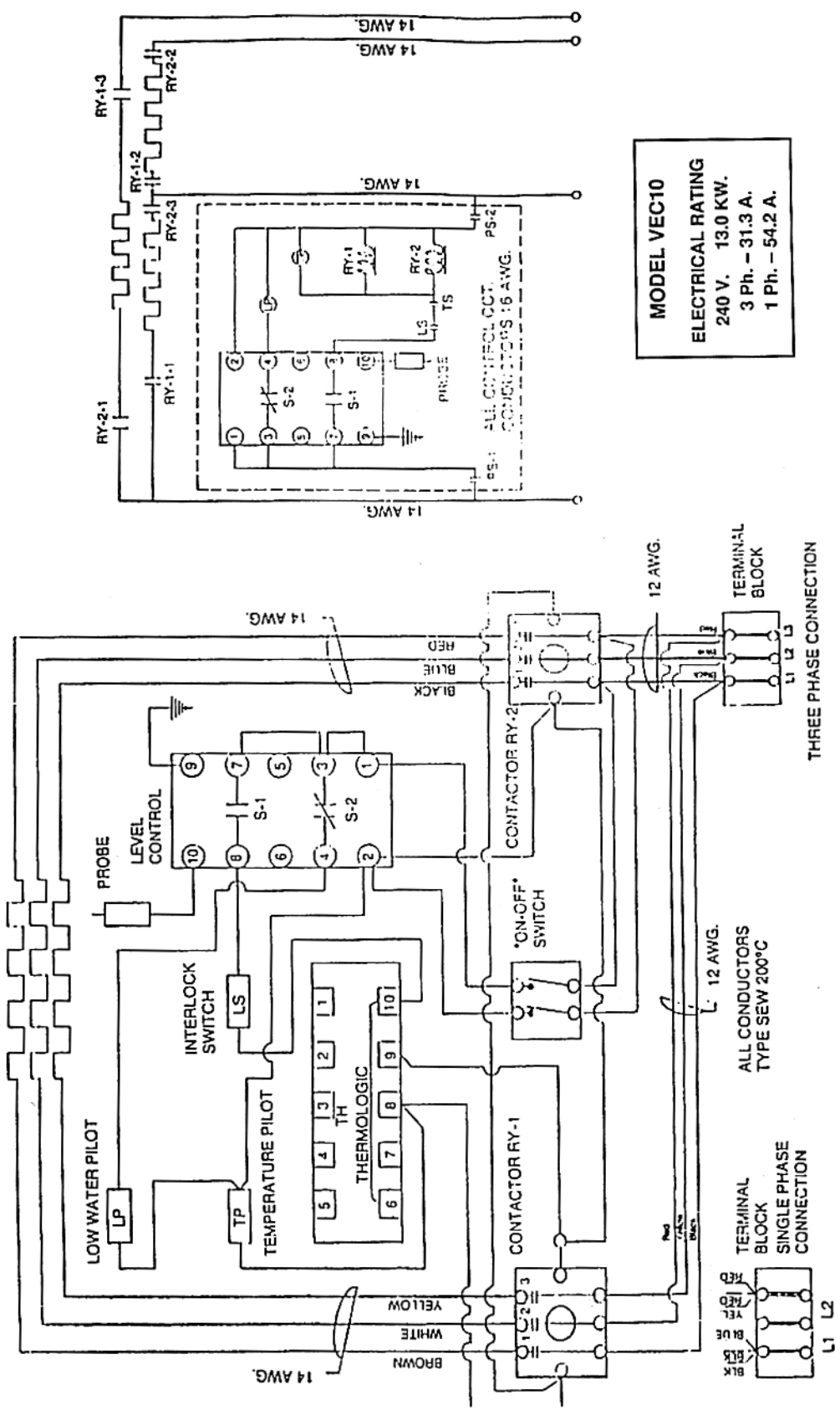

MODEL VEC10
ELECTRICAL RATING
 240 V. 13.0 KW.
 3 Ph. - 31.3 A.
 1 Ph. - 54.2 A.

ALL CONDUCTORS
 TYPE SEW 200°C

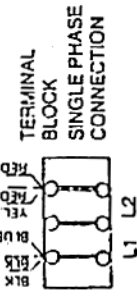

THREE PHASE CONNECTION

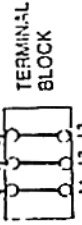

WIRING DIAGRAM: MODEL VEC10: 240/415 VOLTS

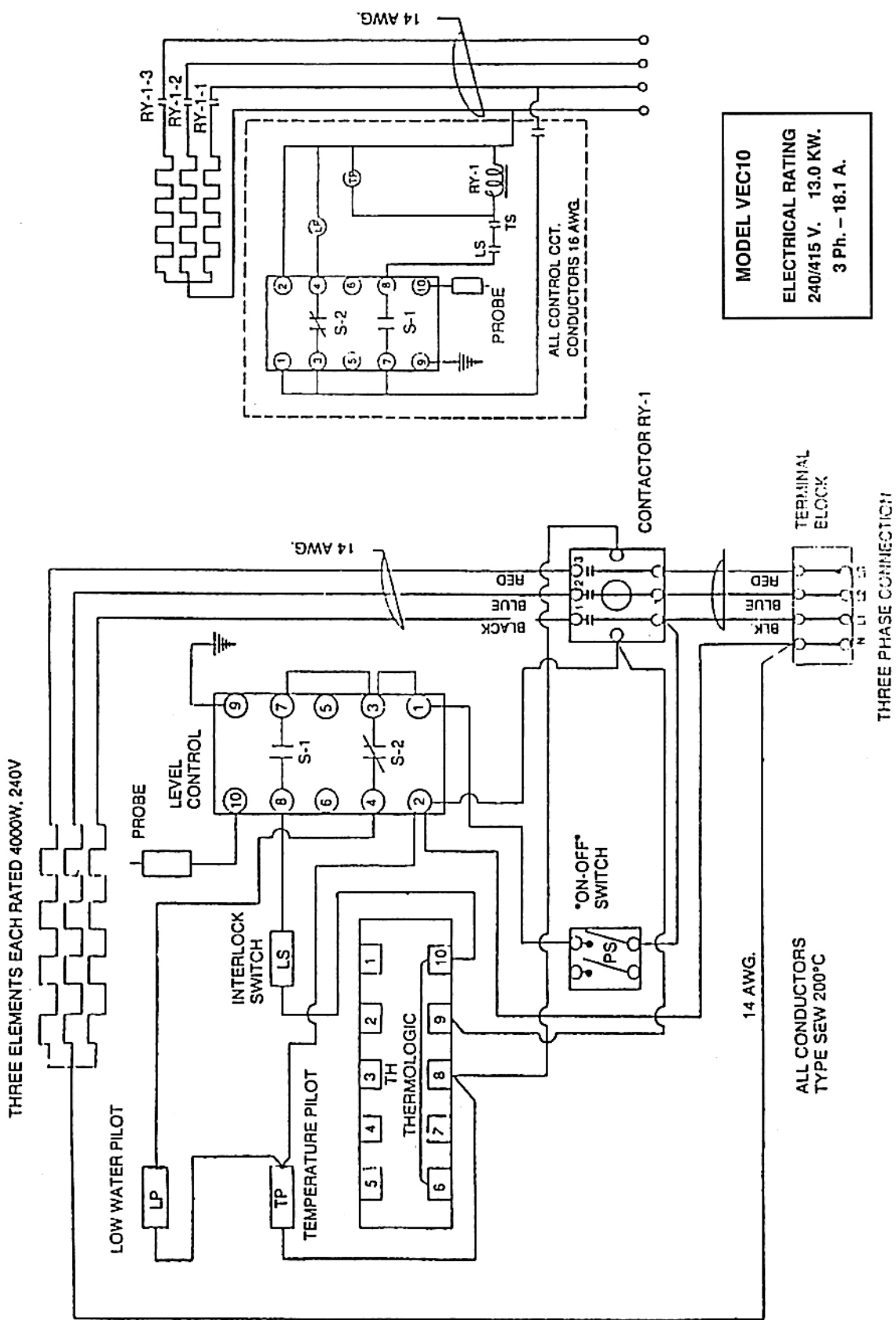

WIRING DIAGRAM: MODEL VEC10: 480 VOLTS

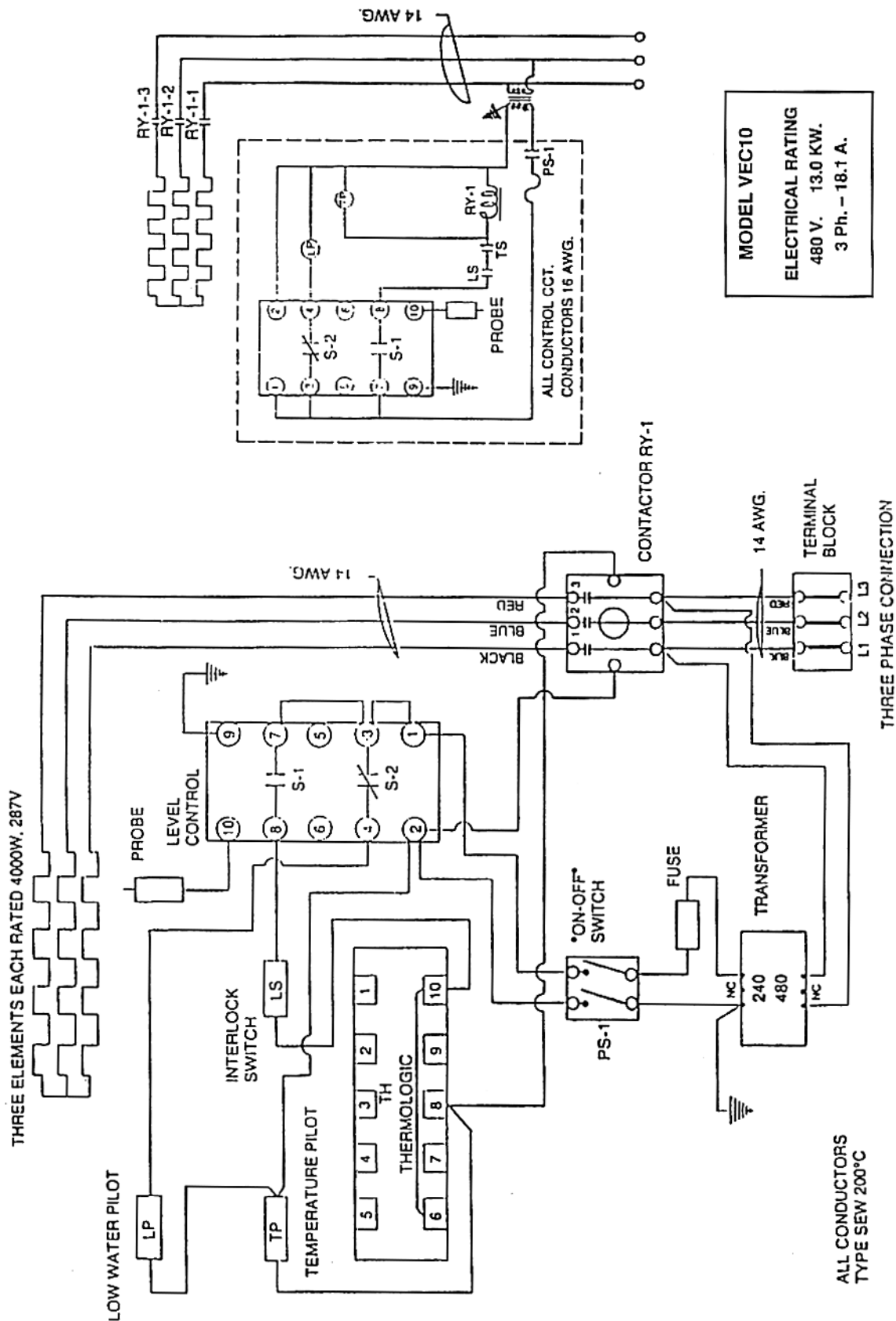

WIRING DIAGRAM: MODEL VEC20: 208 VOLTS

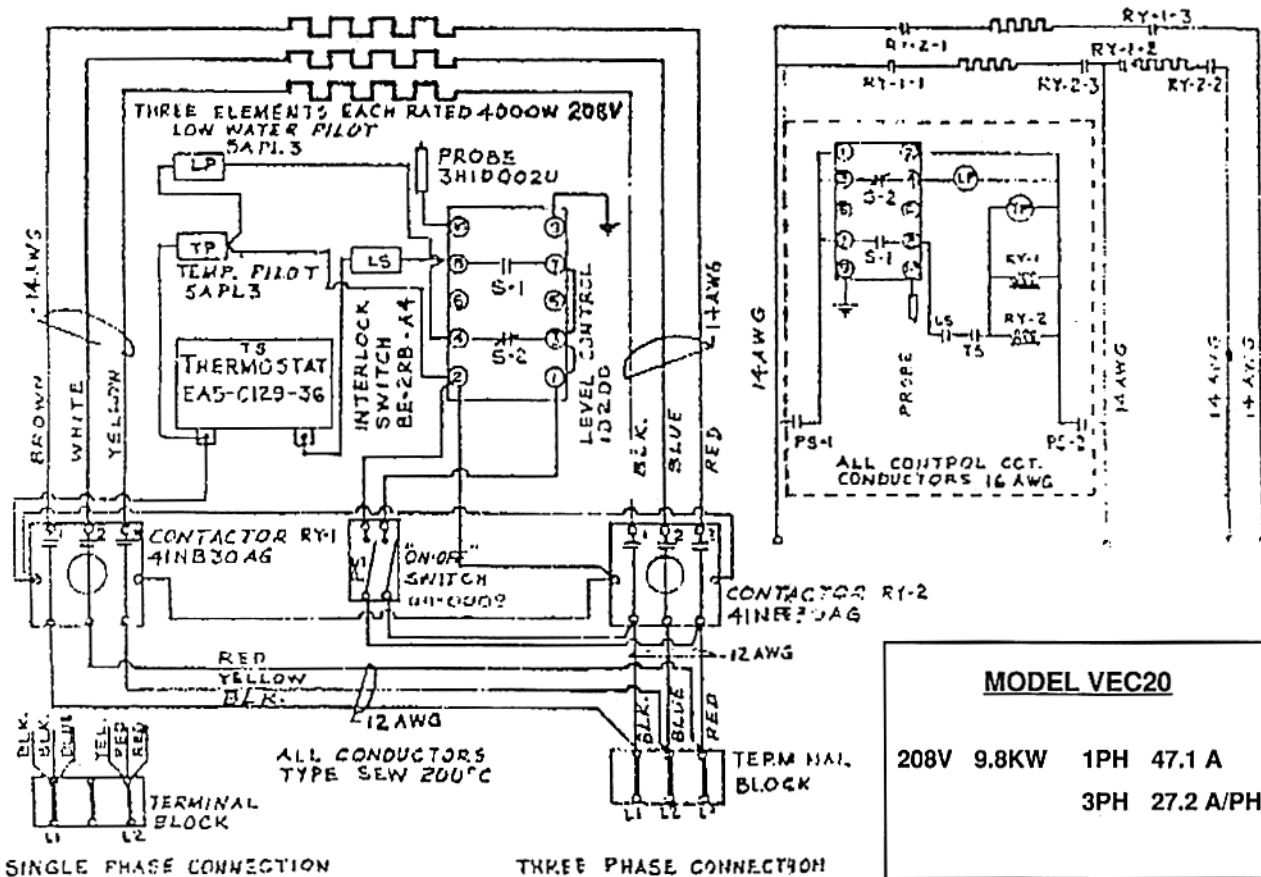

THIS
PAGE
INTENTIONALLY
LEFT
BLANK