



VHG Fryer Series

VHG A SERIES

VHG C SERIES

VHG D SERIES

- NOTICE -

This Manual is prepared for the use of trained Hobart Service Technicians and should not be used by those not properly qualified.

This manual is not intended to be all encompassing. If you have not attended a Hobart Service School for this product, you should read, in its entirety, the repair procedure you wish to perform to determine if you have the necessary tools, instruments and skills required to perform the procedure. Procedures for which you do not have the necessary tools, instruments and skills should be performed by a trained Hobart Service Technician.

The reproduction, transfer, sale or other use of this manual, without the express written consent of Hobart, is prohibited.

This manual has been provided to you by ITW Food Equipment Group LLC ("ITW FEG") without charge and remains the property of ITW FEG, and by accepting this manual you agree that you will return it to ITW FEG promptly upon its request for such return at any time in the future.

TABLE OF CONTENTS

GENERAL	4
INTRODUCTION	4
KLEENSCREEN PLUS FILTRATION SYSTEM: (KSP)	4
INSTALLATION	4
OPERATION	4
CLEANING	4
TOOLS	4
SPECIFICATIONS	5
REMOVAL AND REPLACEMENT OF PARTS	6
C & D CONTROL PANEL COVER	6
ANALOG CONTROL BOARD	7
SIDE PANELS	7
BURNER	8
BULLNOSE	9
POWER SUPPLY BOX	10
OIL RETURN SOLENOID	11
GAS COMBINATION VALVE	12
PUMP/MOTOR ASSEMBLY	12
TEMPERATURE PROBE	14
ORIFICE	14
POWER SWITCH / DISCARD HOSE SWITCH	15
HIGH LIMIT	15
PILOT ASSEMBLY	15
FLAME SENSE WIRE	16
TRANSFORMER	17
IGNITION MODULE	17
PUMP AND OIL RETURN SOLENOID RELAYS	17
DRAIN VALVE	18
DRAIN VALVE SWITCH (D.V.I.)	18
CONTROL INTERFACE BOARD	19
PILOT ORIFICE	19
FRY TANK	20
SERVICE PROCEDURES AND ADJUSTMENTS	26
DRAIN OIL	26
ELECTRIC CONNECTIONS	26
TEMPERATURE PROBE FAULT CODES	26
TEMPERATURE PROBE TEST	26
COOKING CONTROL CALIBRATION	27
FLAME SENSE CURRENT CHECK	28
ELECTRONIC IGNITION CONTROL	28
GAS MANIFOLD PRESSURE ADJUSTMENT	29
SERVICE PROGRAMMING	31
VHG A CONTROL SERVICE PROGRAMMING	31
VHG C CONTROL SERVICE PROGRAMMING	32
VHG D CONTROL SERVICE PROGRAMMING	34
ELECTRICAL OPERATION	36
COMPONENT FUNCTION	36
COMPONENT FUNCTION - KLEENSCREEN FILTER CONTROLS	36
COMPONENT LOCATION	37
SEQUENCE OF OPERATION VHG FILTERING	39
SEQUENCE OF OPERATION VHG HEATING	40
SCHEMATICS	42
WIRING DIAGRAMS	43

TRoubleshooting 51
 TRoubleshooting 51
 INTERFACE CONTROL BOARD PIN-OUTS 53
 VHG PREVENTATIVE MAINTENANCE CHECKLIST 54

GENERAL

INTRODUCTION

This service manual covers the specific service information related to the models listed in the chart below. The VHG series gas fryers come equipped with solid state analog (A), solid state digital (D) or programmable computer (C) controls. This manual covers single floor model fryers, battery fryers as well as fryers with the KleenScreen PLUS® Filtration System.

KLEENSCREEN PLUS FILTRATION SYSTEM: (KSP)

The KleenScreen PLUS® filtration system is integrated into the VHG Series fryer battery. The filter screen is housed in a pullout drawer assembly at the base of the fryer. The filtering components in the drawer include a stainless-steel filter tank, a stainless steel mesh filter screen with a stainless-steel insert, a suction tube and double handle nut and mechanical seal to close the assembly. In addition, the KSP has the availability of an optional filtering system; a microfiltration fabric envelope (3), a dedicated stainless steel insert and stainless-steel clip that holds the assembly together. With the filter drawer closed, a self-sealing oil return line provides the path to return the filtered shortening back into the fry tank.

This system is designed to provide a thorough and easy method to filter the shortening. Some of the benefits include:

- Self-contained system eliminating the use of external filter equipment
- Paperless filtering system.
- Easy to clean and low maintenance.
- Extends the life of the shortening.

KSP fryer batteries are standard in single and up to a maximum of a four-fryer battery in most cases. Batteries are made up of only fryers, no warming stations.

INSTALLATION

Refer to Instruction Manual for detailed installation instructions.

- [VHG-A SERIES GAS FRYERS INSTALLATION AND OPERATION](#)

- [VHG-C-D SERIES GAS FRYERS INSTALLATION AND OPERATION](#)

OPERATION

Refer to the Instruction Manual for specific operating instructions.

- [VHG-A SERIES GAS FRYERS INSTALLATION AND OPERATION](#)
- [VHG-C-D SERIES GAS FRYERS INSTALLATION AND OPERATION](#)

CLEANING

Refer to the Instruction Manual for specific cleaning instructions.

- [VHG-A SERIES GAS FRYERS INSTALLATION AND OPERATION](#)
- [VHG-C-D SERIES GAS FRYERS INSTALLATION AND OPERATION](#)

TOOLS

Standard

- Standard set of hand tools.
- Metric set of hand tools.
- VOM with measuring micro amp current tester. Any VOM with minimum of CAT III 600V, CE certified. Sensitivity of at least 20,000 ohms per volt can be used. In addition, meter leads must also be a minimum of CAT III 600V.
- Clamp on type amp meter with minimum of NFPA-70E CAT III 600V, UL/CSA/TUV listed.
- Temperature tester (thermocouple type).
- Field service grounding kit.

Special

- Temperature tester (thermocouple type).
- Manometer.
- Set of jeweler's screwdrivers.
- Burndy pin extraction tool RX2025 GE1; Newark Electronics Catalog Number 16F6666. Used for removing pin terminals on Burndy connectors.
- Thumb drive (part number 443444).
- RECTORSEAL 5® or equivalent NSF rated thread sealant.

NOTE: Menu Editor software will be available for download on the Vulcan website. Output from this software is compatible with the new VHG C-control.

SPECIFICATIONS

GAS TYPE	OPERATING PRESSURE	BUILDING SUPPLY PRESSURE (MAXIMUM) Note: Building supply pressure max 1/2 psi. (14" W.C.)	SERVICE CONNECTION	ELECTRICAL
Natural	3.5" W. C.	7" W.C. NOTE: Not to exceed 14" W. C.	1/2" (13 mm) ID and 3/4" (19 mm) OD rear gas connection for single units and 1-1/4"(31.75mm) for battery units.	120V Unit Only: NEMA 5-15P 120 Volt cord & plug supplied with fryers. 120V unit only. NOTE: 240V unit not shipped with plug and cord.
Propane	10.0" W. C.	11" W.C. NOTE: Not to exceed 14" W. C.		

Refer to Specification Sheets

- [1VHG50 SERIES SPECIFICATIONS](#)
- [1VHG75 SERIES SPECIFICATIONS](#)

REMOVAL AND REPLACEMENT OF PARTS

C & D CONTROL PANEL COVER



WARNING

Disconnect the electrical power to the machine and follow lockout / tagout procedures.

1. Remove control panel mounting screws.



Fig. 1

2. Control board replacement.
 - Note and disconnect wiring from interface board (1, Fig. 2).
 - If replacing control board, remove mounting screws and replace.
 - Reverse procedure at this step and verify operation.

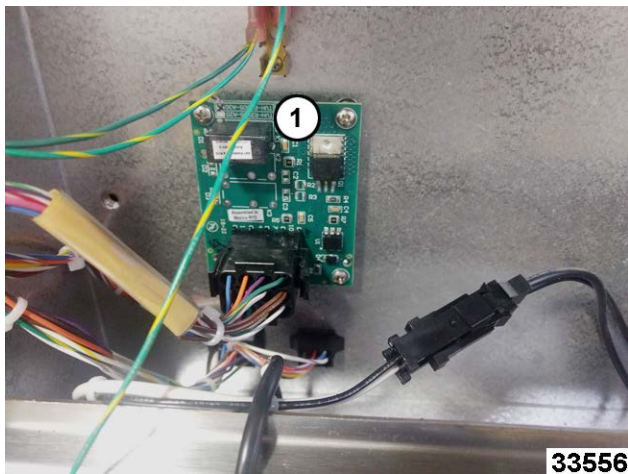

Fig. 2

NOTE: Control mount plate only needs removed if replacing the bullnose.

3. Remove control mount plate.
 - Screws on both sides (Fig. 3).
 - Allen screws underneath (Fig. 4).

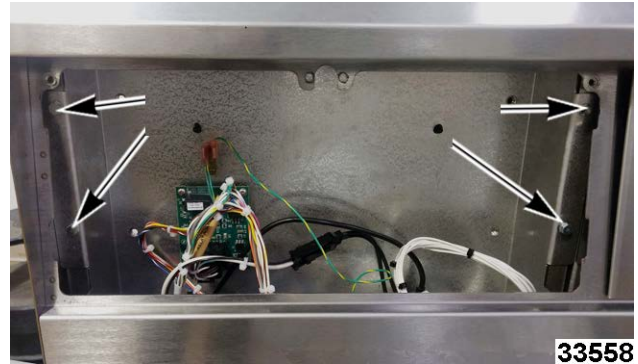

Fig. 3



Fig. 4

NOTE: Connections on back of control mount plate are connectors for USB (1, Fig. 5), and C-control connector harness (2, Fig. 5).



Fig. 5

NOTICE

D-control has two connectors, input and output. Verify these connections for misalignment of pins after installing, carefully fix a pin if it gets bend over. A replacement controller will need to be set to the fryer's matching service control parameters before operating. Refer to: VHG A CONTROL SERVICE PROGRAMMING, VHG C CONTROL SERVICE PROGRAMMING and VHG D CONTROL SERVICE PROGRAMMING.

4. Reverse procedure to install.

ANALOG CONTROL BOARD



⚠ WARNING

Disconnect the electrical power to the machine and follow lockout / tagout procedures.

1. Open access door (1, Fig. 6) to analog control board.

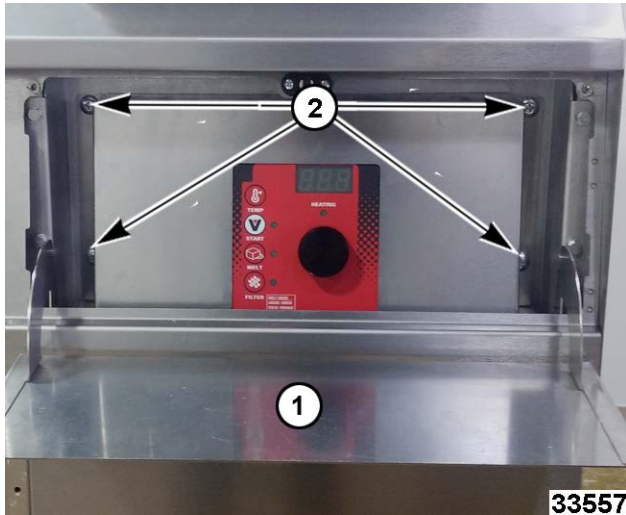

Fig. 6

2. Remove control panel mount screws (2, Fig. 6).
3. Note and disconnect wire connections (Fig. 7) from back of control board.

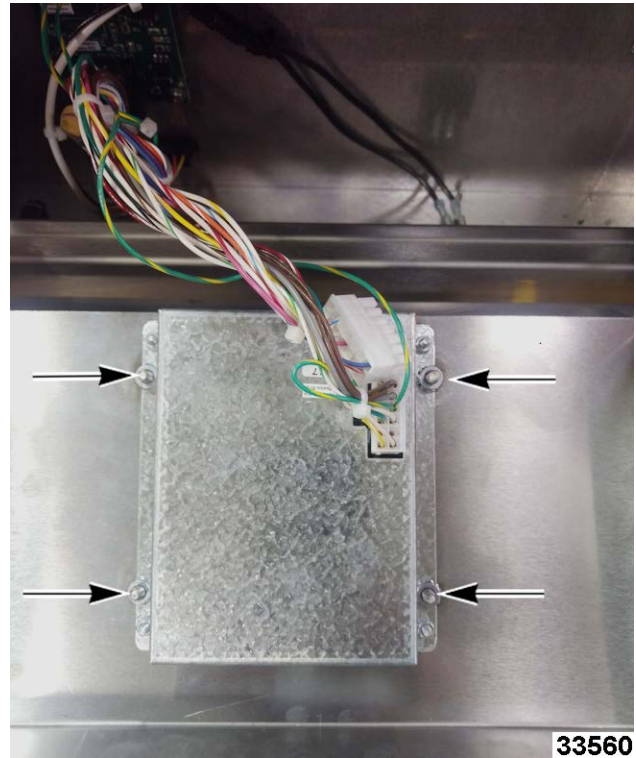

Fig. 7

4. Remove analog control board mounting nuts (Fig. 7).
5. Set replacement controller to fryer's matching service control parameters before operating. Refer to: VHG A CONTROL SERVICE PROGRAMMING, VHG C CONTROL SERVICE PROGRAMMING, and VHG D CONTROL SERVICE PROGRAMMING.
6. Reverse procedure to install.

SIDE PANELS



⚠ WARNING

Disconnect the electrical power to the machine and follow lockout / tagout procedures.

1. Remove mounting screws (1, Fig. 8).

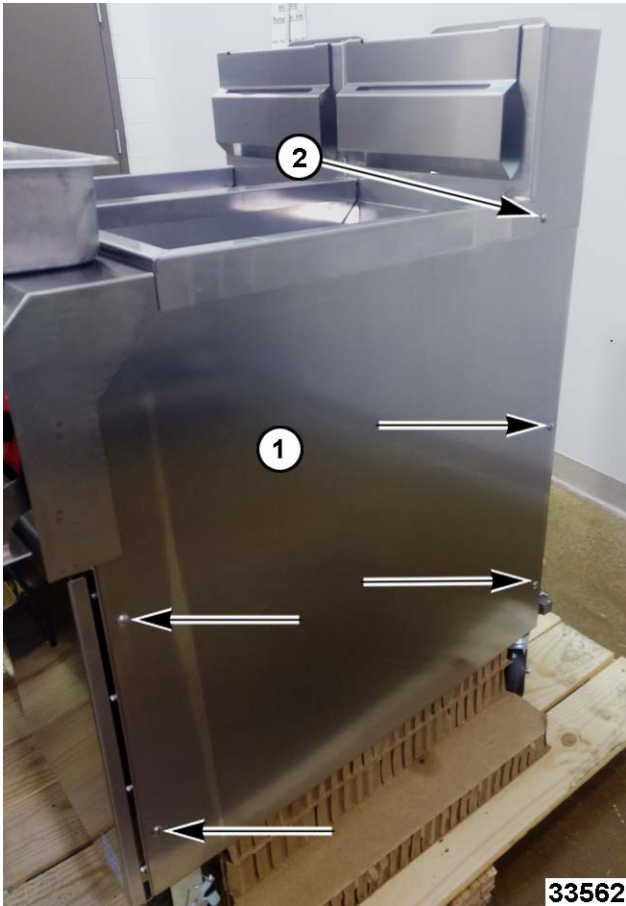

Fig. 8

2. Loosen flue screw (2, Fig. 8) while carefully holding side panel.
3. Position panel under bullnose and tank side lip.
4. Install screws (1, Fig. 8).
5. Retighten flue screw (2, Fig. 8).

BURNER



⚠ WARNING

Disconnect the electrical power to the machine and follow lockout / tagout procedures.



⚠ WARNING

Shut off the gas before servicing the unit and follow lockout / tagout procedures.

1. Remove BULLNOSE.
2. Remove flame sense wire (1, Fig. 9).

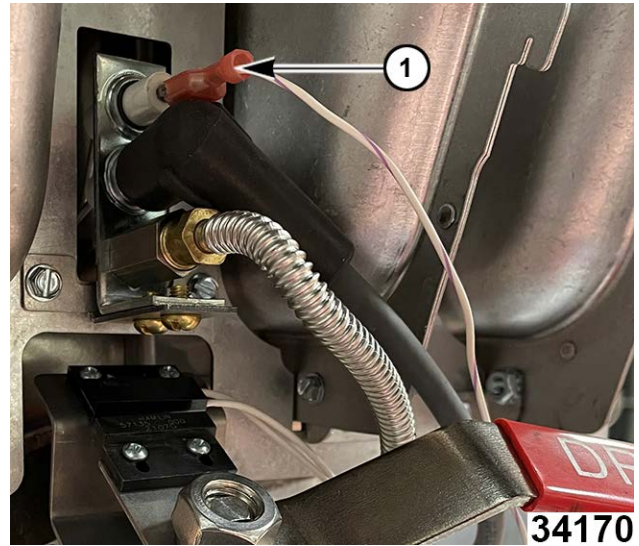

Fig. 9

3. Unplug igniter cable.
4. Disconnect gas line.



Fig. 10

5. Remove burner mounting nuts from tank welded stud.

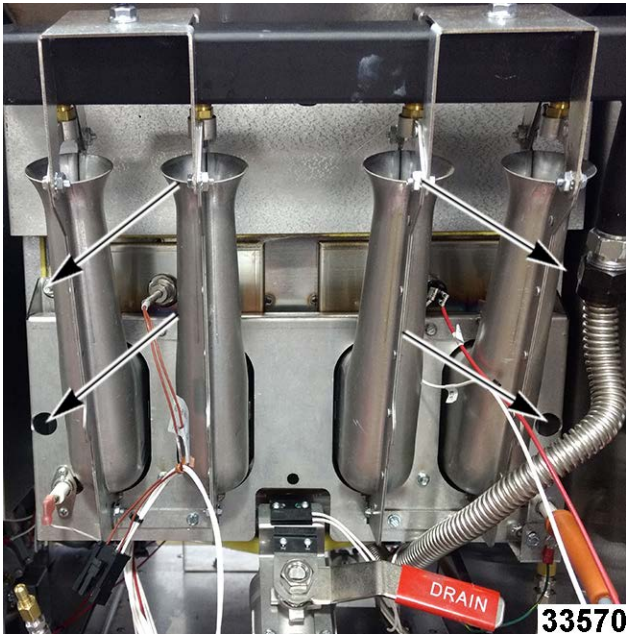

Fig. 11

6. Remove burners and manifold from front of tank as one assembly. Pull away from tank face and off studs that are welded to tank.
7. Remove burners bracket mounting nuts on top and bottom to remove burners from brackets.

TOP NUTS



Fig. 12

BOTTOM NUTS



Fig. 13

8. Reverse procedure to install.

⚠ WARNING

All gas joints disturbed during servicing must be checked for leaks. Check with a soap and water solution (bubbles). Do not use an open flame.

9. Verify proper operation.

BULLNOSE



⚠ WARNING

Disconnect the electrical power to the machine and follow lockout / tagout procedures.

1. Remove C & D CONTROL PANEL COVER or ANALOG CONTROL BOARD cover.



Fig. 14

2. Remove control panel box.

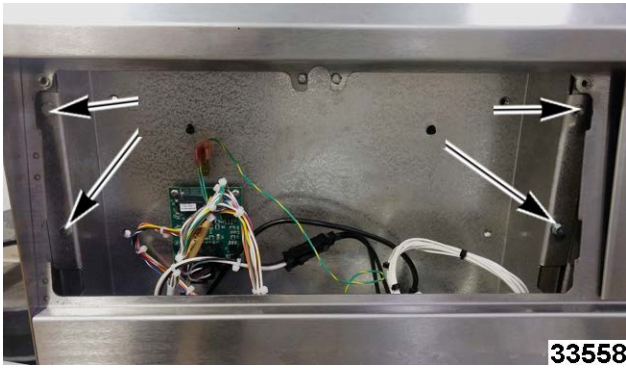

Fig. 15

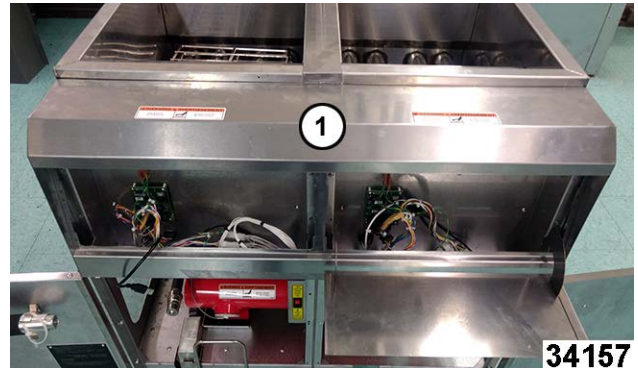

Fig. 17

3. Open lower door.
4. Note and disconnect front to back wire harness connections.
5. Remove top door mounting screw (1, Fig. 16) and loosen two screws (2, Fig. 16) below.

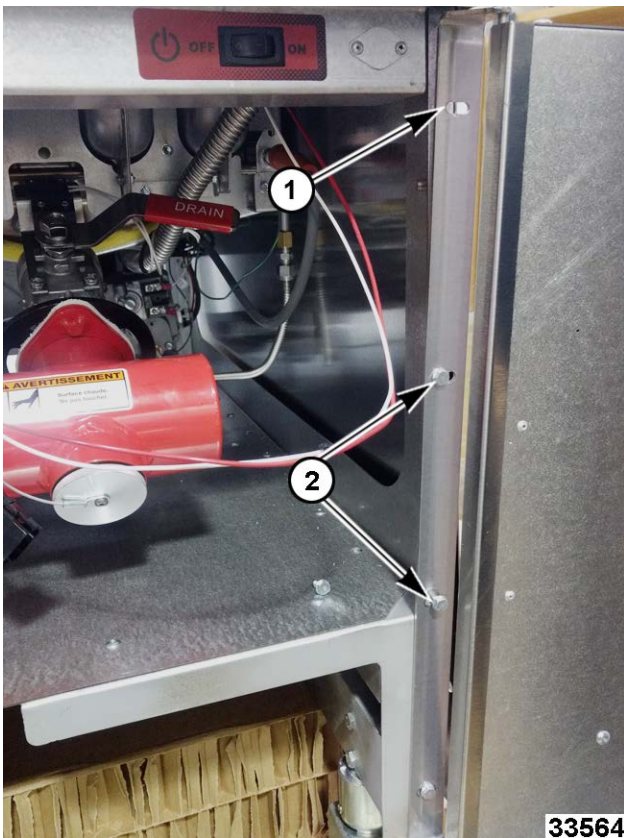

Fig. 16

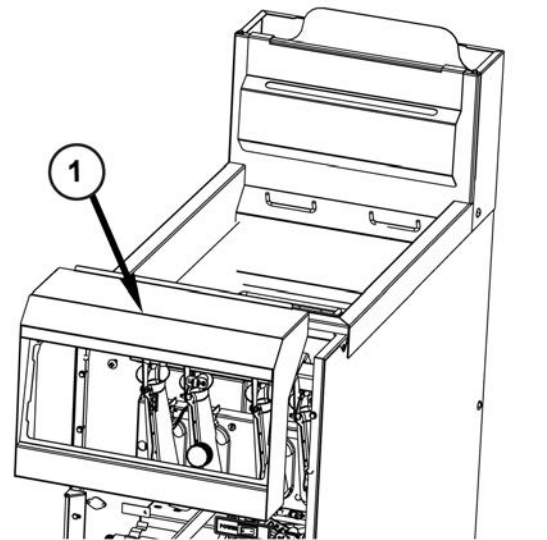

Fig. 18

6. Lift up and out to remove bullnose (1, Fig. 17 and Fig. 18).

7. Reverse procedure to install.
8. Verify operation.

POWER SUPPLY BOX



⚠ WARNING

Disconnect the electrical power to the machine and follow lockout / tagout procedures.

⚠ WARNING

This procedure applies to a single tank unit power supply box. If working on a multiple tank unit, disconnect the power supply box to each tank unit. Battery units will have to be accessed from the back of machine. Use special care when opening the wiring clip attached to power box from the back side of fryer.

1. Remove SIDE PANEL.

- Unplug power cord to power supply box (1, Fig. 19). Note and disconnect wire connectors.

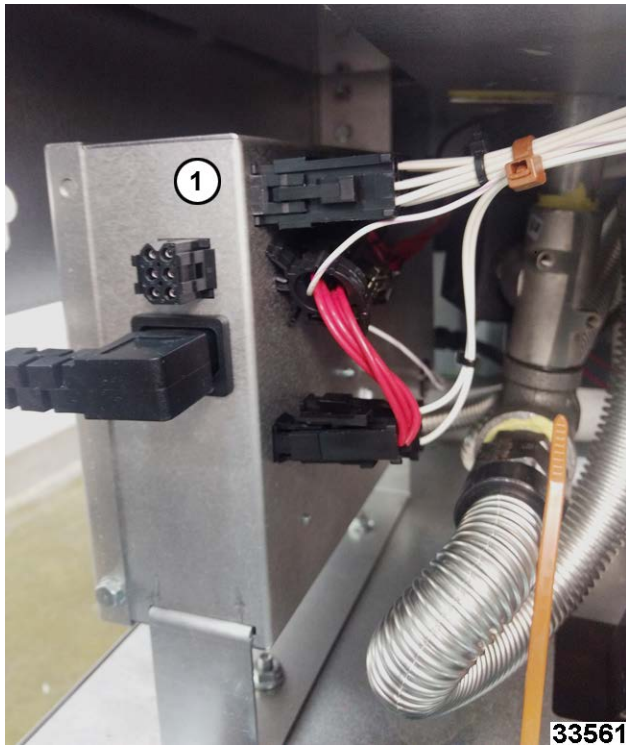

Fig. 19

- Remove mounting nuts. Reach power box mounting nuts through rear of fryer if accessible.



Fig. 20

- Reverse procedure to install.
- Verify proper operation.

OIL RETURN SOLENOID



⚠ WARNING

Disconnect the electrical power to the machine and follow lockout / tagout procedures.

- DRAIN OIL from tank.
- Remove POWER SUPPLY BOX.
- Note and disconnect piping and wiring from solenoid.
- Remove solenoid (1, Fig. 21).

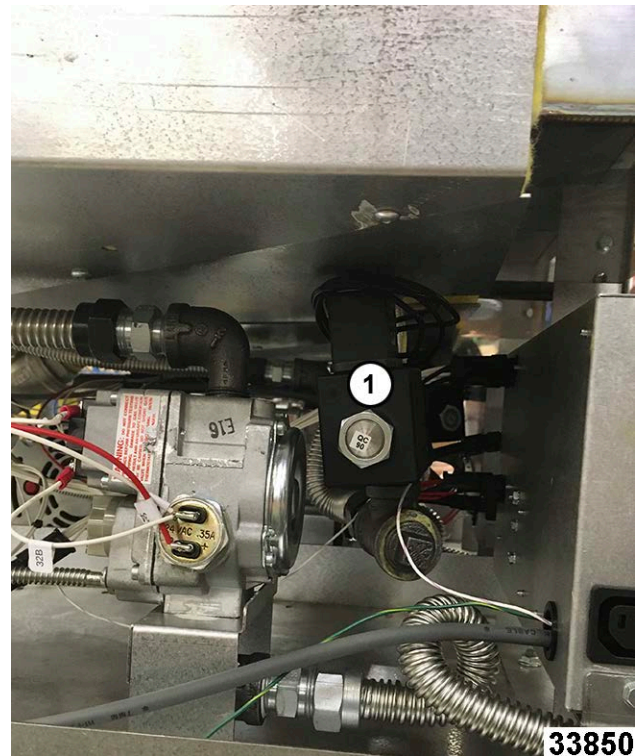

Fig. 21

- Reverse procedure to install.
- Verify operation.

GAS COMBINATION VALVE



⚠ WARNING

Disconnect the electrical power to the machine and follow lockout / tagout procedures.



⚠ WARNING

Shut off the gas before servicing the unit and follow lockout / tagout procedures.

1. Remove POWER SUPPLY BOX.
2. Disconnect gas piping from gas combination valve.
3. Disconnect pilot tubing.
4. Note and remove wiring.
5. Remove valve bracket nuts.

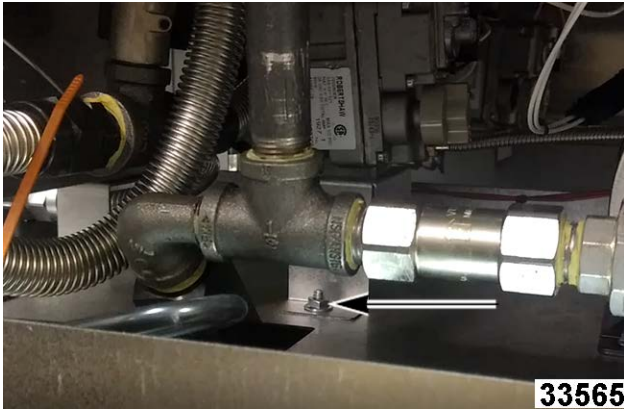

Fig. 22

6. Reverse procedure to install.

⚠ WARNING

All gas joints disturbed during servicing must be checked for leaks. Check with a soap and water solution (bubbles). Do not use an open flame.

7. Verify proper operation.

PUMP/MOTOR ASSEMBLY



⚠ WARNING

Disconnect the electrical power to the machine and follow lockout / tagout procedures.



⚠ WARNING

Shut off the gas before servicing the unit and follow lockout / tagout procedures.

1. Remove SIDE PANELS.
2. Disconnect pump piping flex lines.
 - A. Flex lines to solenoid valve connection.
 - B. Flex line on left side of pump.
 - C. Flex line from front of pump.
3. Remove U-bolt (1, Fig. 23) nuts (Fig. 24).

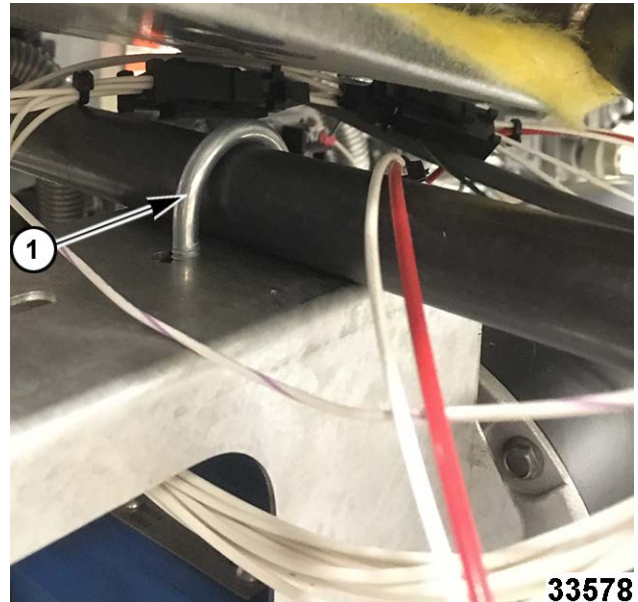

Fig. 23

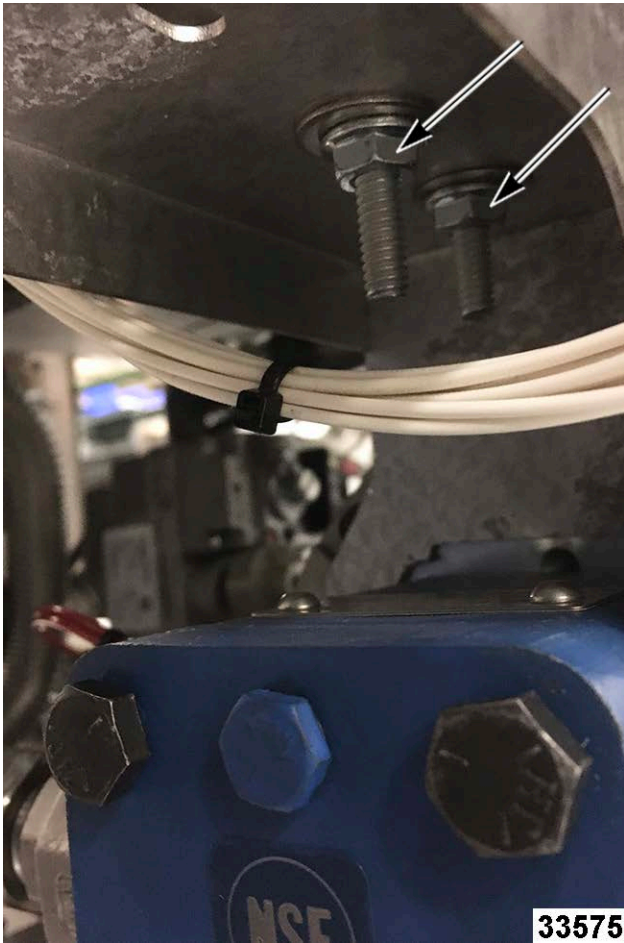

Fig. 24

4. Note and disconnect motor wiring connector from power box.
5. Disconnect pipe system union connection.
6. Remove pipe system through side of fryer. (careful to not hit the gas valve of the next fryer over).
7. Remove motor mounting flange nuts.

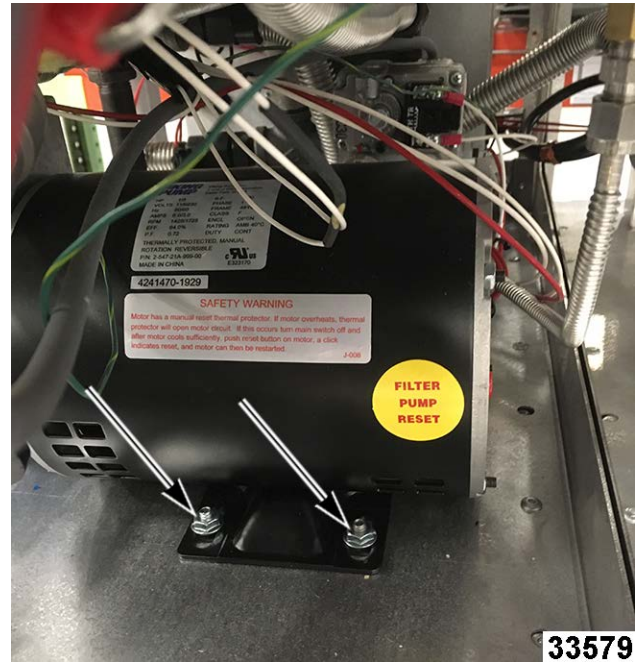

Fig. 25

8. Lift and remove pump motor through side of next fryer over.
9. Disassemble remaining pump connections on inlet of pump.
10. Disassemble remaining pump connections on discharge of pump.
11. Remove pipe mount bracket from pump.
12. Note electrical connections and disconnect harness from pump motor. Reconnect new pump motor wires in any order to terminal 1 and 4.

NOTICE

It is recommended to replace pipe nipples that were removed from original pump housing. Use NSF approved pipe thread sealant during installation (i.e., RECTORSEAL 5®).

13. Reverse procedure to install.

WARNING

All gas joints disturbed during servicing must be checked for leaks. Check with a soap and water solution (bubbles). Do not use an open flame.

14. Verify proper operation.

TEMPERATURE PROBE



⚠ WARNING

Disconnect the electrical power to the machine and follow lockout / tagout procedures.

1. Remove LEFT SIDE PANEL.
2. Drain liquid from tank.
3. Note and disconnect temperature probe lead wires.
4. Loosen packing nut (1, Fig. 26).

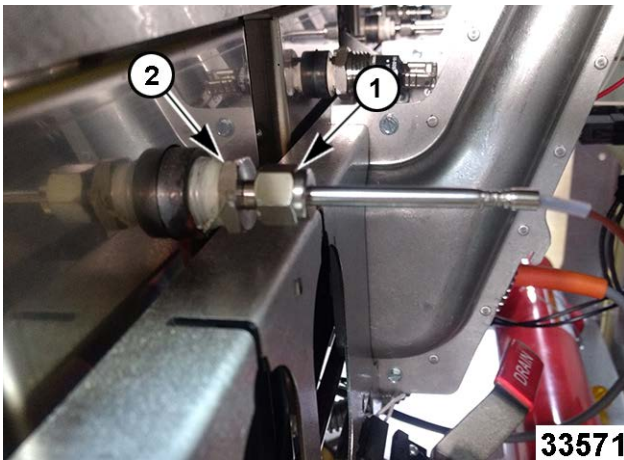

Fig. 26

5. Remove mounting nut (2, Fig. 26).
6. Remove probe.
7. Reverse procedure to install.

NOTICE

Use a high temperature thread sealant to prevent leaking. RECTORSEAL 5® or equivalent NSF rated high temperature thread sealant is recommended.

⚠ WARNING

All gas joints disturbed during servicing must be checked for leaks. Check with a soap and water solution (bubbles). Do not use an open flame.

8. Verify proper operation.

ORIFICE



⚠ WARNING

Disconnect the electrical power to the machine and follow lockout / tagout procedures.



⚠ WARNING

Shut off the gas before servicing the unit and follow lockout / tagout procedures.

1. Remove BULLNOSE.
2. Remove BURNERS.
3. Remove orifice (1, Fig. 27).

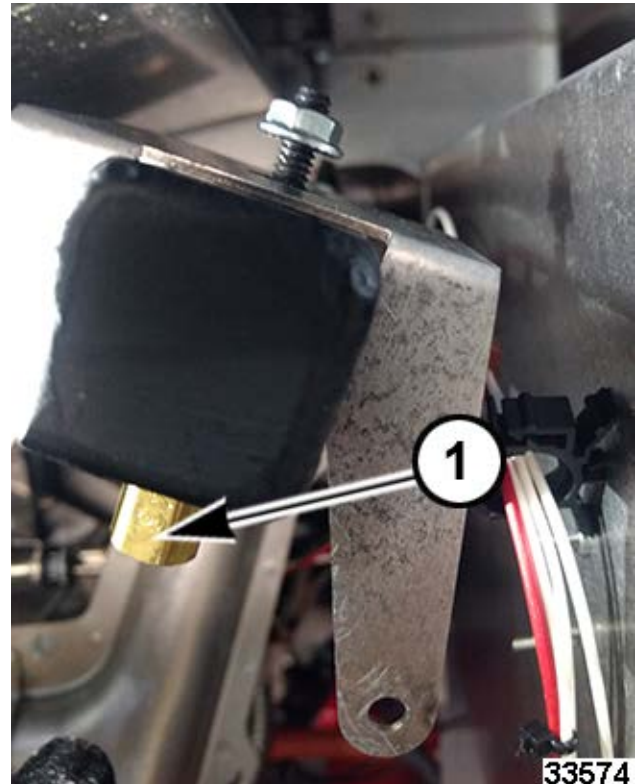

Fig. 27

4. Reverse procedure to install.

⚠ WARNING

All gas joints disturbed during servicing must be checked for leaks. Check with a soap and water solution (bubbles). Do not use an open flame.

POWER SWITCH / DISCARD HOSE SWITCH



⚠ WARNING

Disconnect the electrical power to the machine and follow lockout / tagout procedures.

1. Open door to locate power switch (1, Fig. 28) and discard hose switch (2, Fig. 28).

NOTE: For power switch remove CONTROL PANEL to access back of switch.

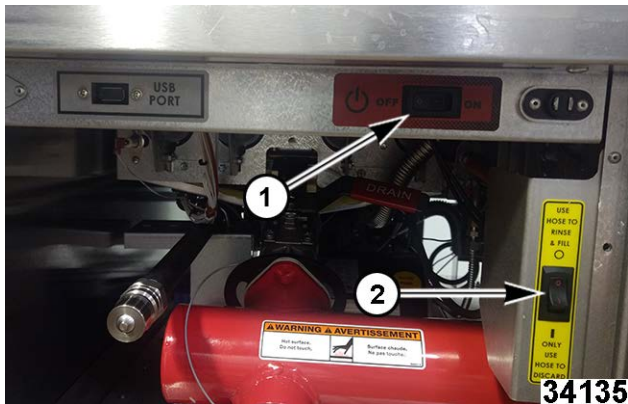

Fig. 28

2. Unplug switch from wire harness.
3. Squeeze switch retainers on back of switch while prying out switch (from sheet metal) to the front of unit.
4. Reverse procedure to install.
5. Verify operation

HIGH LIMIT



⚠ WARNING

Disconnect the electrical power to the machine and follow lockout / tagout procedures.

1. Remove RIGHT SIDE PANEL.
2. DRAIN OIL from fry tank.
3. Note and disconnect high limit terminal wires (1, Fig. 29).

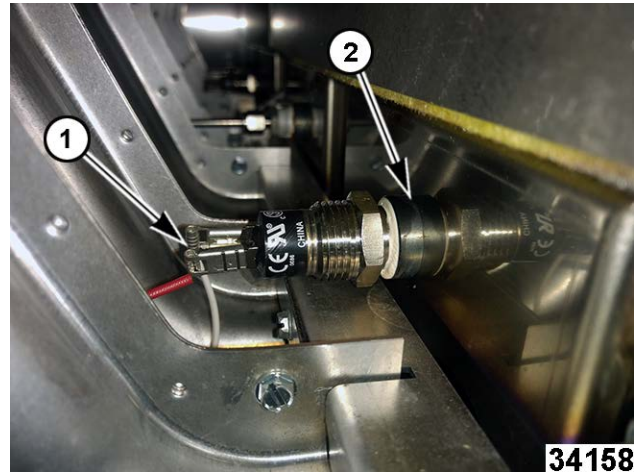

Fig. 29

4. Remove/unthread high limit (2, Fig. 29) from fry tank.
5. Reverse procedure to install.

NOTICE

Use a high temperature thread sealant to prevent leaking. **RECTORSEAL 5®** or equivalent NSF rated high temperature thread sealant is recommended.

6. Verify operation and check for leaks.

PILOT ASSEMBLY



⚠ WARNING

Disconnect the electrical power to the machine and follow lockout / tagout procedures.

1. Disconnect flame sense wire (1, Fig. 30) from flame sensor terminal.

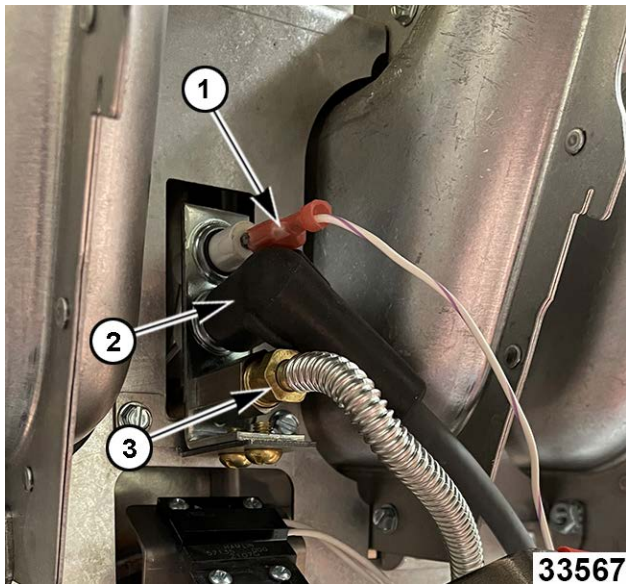

Fig. 30

2. Remove electrode cable (2, Fig. 30).
3. Disconnect pilot gas tube. (3, Fig. 30).
4. Remove pilot assembly mounting screws.



Fig. 31

5. Reverse procedure to install.
6. Verify operation.
 - A. Ensure electrode is sparking to the pilot burner head.
 - B. Spark gap should be 0.120" +/- 0.010".

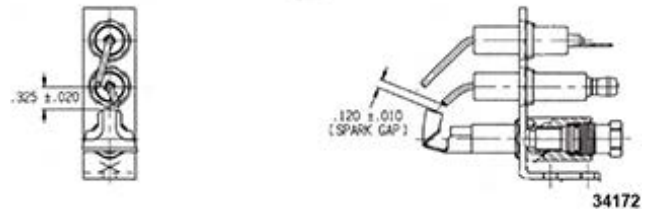

Fig. 32

FLAME SENSE WIRE



WARNING

Disconnect the electrical power to the machine and follow lockout / tagout procedures.

1. Disconnect power supply.
2. Open door.
3. Disconnect flame sense wire terminal.

NOTE: If performing FLAME SENSE CURRENT CHECK, leave flame sense wire terminal connected.

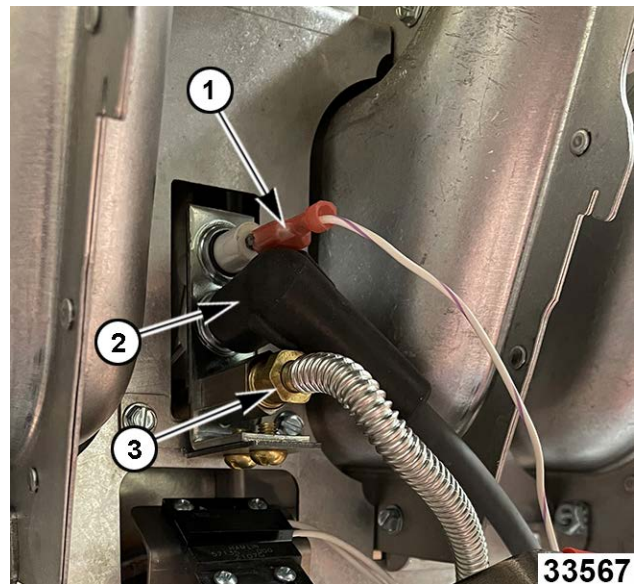

Fig. 33

4. Remove POWER SUPPLY BOX.
5. Remove power supply box lid to test and access flame sense wire. Refer to: FLAME SENSE CURRENT CHECK.

NOTE: Harness may need to be removed from rear tank mounted harness clips for additional stretch room.

6. Reverse procedure to install.
7. Verify proper operation.

TRANSFORMER



⚠ WARNING

Disconnect the electrical power to the machine and follow lockout / tagout procedures.

1. 1. Remove POWER SUPPLY BOX.
2. Remove power supply box lid.
3. Disconnect transformer assembly (1, Fig. 34) wires at harness plug.

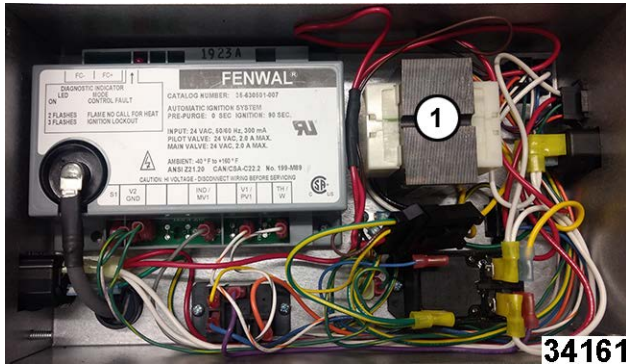

Fig. 34

4. Remove transformer mounting screws.
5. Reverse procedure to install.
6. Verify operation.

IGNITION MODULE



⚠ WARNING

Disconnect the electrical power to the machine and follow lockout / tagout procedures.

1. Remove POWER SUPPLY BOX.
2. Remove power supply box lid.
3. Note and disconnect module (1, Fig. 35) wiring.

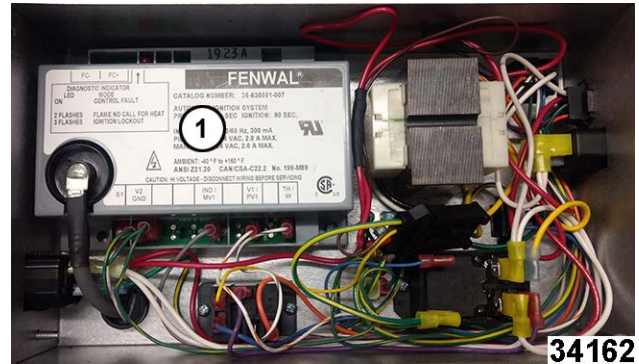

Fig. 35

4. Remove module mounting screws.
5. Reverse procedure to install.
6. Verify operation.

PUMP AND OIL RETURN SOLENOID RELAYS



⚠ WARNING

Disconnect the electrical power to the machine and follow lockout / tagout procedures.

1. Remove POWER SUPPLY BOX.
2. Remove power supply box lid.
3. Note and disconnect oil return solenoid relay (1, Fig. 36) and pump relay (2, Fig. 36) wiring.

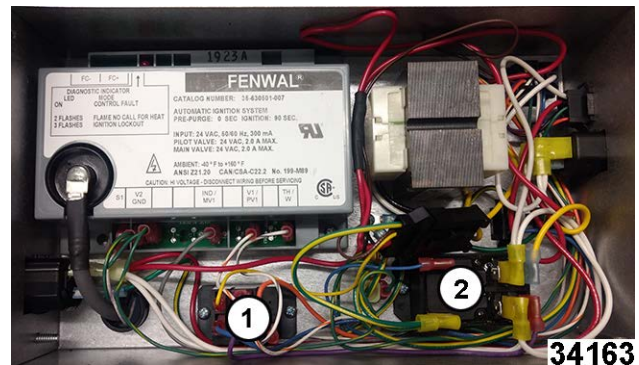

Fig. 36

4. Remove relay mounting screws.
5. Reverse procedure to install.
6. Verify operation.

DRAIN VALVE



⚠ WARNING

Disconnect the electrical power to the machine and follow lockout / tagout procedures.

1. Open door.
2. Remove SIDE PANELS.
3. DRAIN liquid from fry tank.
4. Remove drain manifold (1, Fig. 37) and flange gasket (2, Fig. 37) if fryer has a filter system.



Fig. 37

5. Remove drain valve handle.
6. Note and disconnect drain valve switch wires at plug.
7. Remove drain valve and manifold flange assembly.
8. Note dimensions listed before separating flange from valve.
 - Bottom of old valve to flange.
 - Top of the valve to the tank.

NOTICE

These dimensions will need to be duplicated when flange is reinstalled on the replacement valve. This will ensure the drain manifold will be installable and level. Units without a filter system will not have a drain manifold flange.

Note dimension before removing

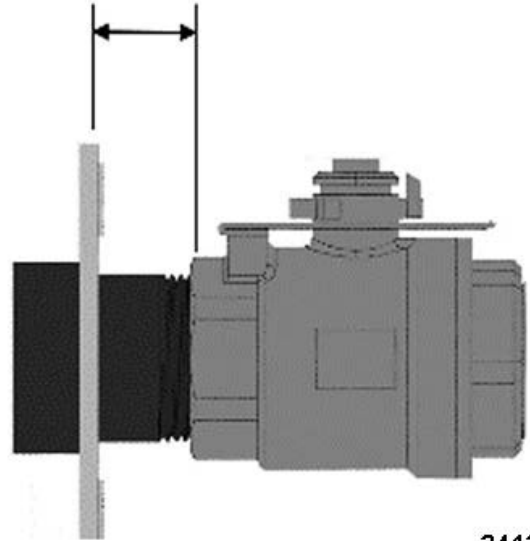

Fig. 38

9. Remove drain manifold flange from the valve.
10. Reverse procedure to install.
11. Use a high temperature thread sealant.
12. Verify operation and check for leaks.

DRAIN VALVE SWITCH (D.V.I.)



⚠ WARNING

Disconnect the electrical power to the machine and follow lockout / tagout procedures.

1. Open door.
2. Note and disconnect drain valve switch wires at plug.
3. Remove switch mounting screws.

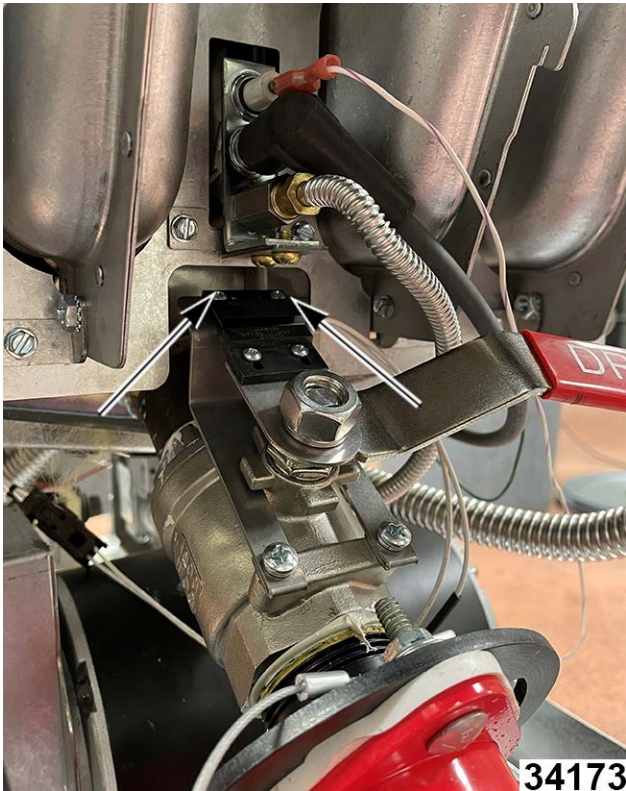

Fig. 39

4. Reverse procedure to install.
5. Verify operation.

CONTROL INTERFACE BOARD



⚠ WARNING

Disconnect the electrical power to the machine and follow lockout / tagout procedures.

1. Remove CONTROL PANEL COVER.
2. Disconnect interface board wire harness plug (1, Fig. 40).

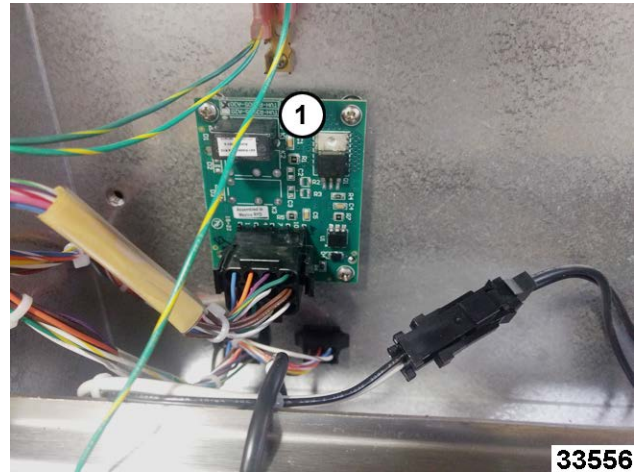

Fig. 40

3. Remove interface board mounting screws (2, Fig. 40).
4. Reverse procedure to install.
5. Verify operation.

PILOT ORIFICE



⚠ WARNING

Disconnect the electrical power to the machine and follow lockout / tagout procedures.

1. Disconnect flame sense wire (1, Fig. 41).

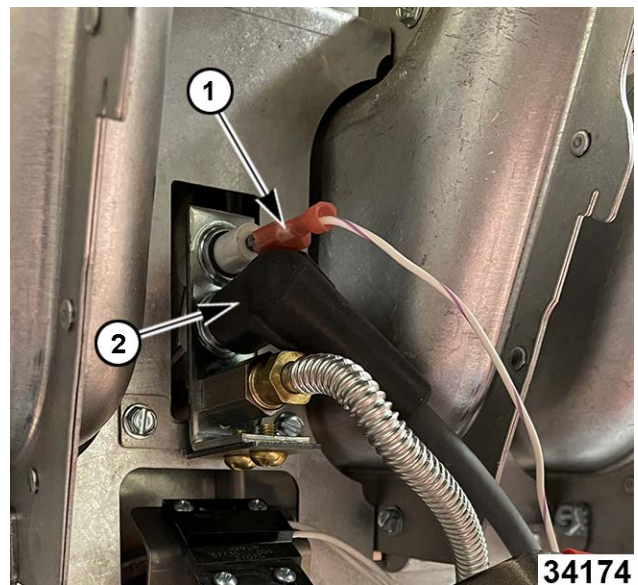

Fig. 41

2. Disconnect electrode cable (2, Fig. 41).
3. Disconnect pilot tube.



Fig. 42

4. Remove orifice from pilot assembly.
5. Reverse procedure to install.
6. Verify operation.

FRY TANK



⚠ WARNING

Disconnect the electrical power to the machine and follow lockout / tagout procedures.



⚠ WARNING

Shut off the gas before servicing the unit and follow lockout / tagout procedures.

1. DRAIN fry tank.
2. Remove the following:
 - A. Fry baskets.
 - B. Basket holder (1, Fig. 43).



Fig. 43

- C. Basket rack.
- D. Outer flue panel (1, Fig. 44).



Fig. 44

- E. SIDE PANELS .
- F. BULLNOSE .
- G. Banking strip (1, Fig. 45) (if a multiple vat unit).



Fig. 45

PANELS EXPLODED VIEW

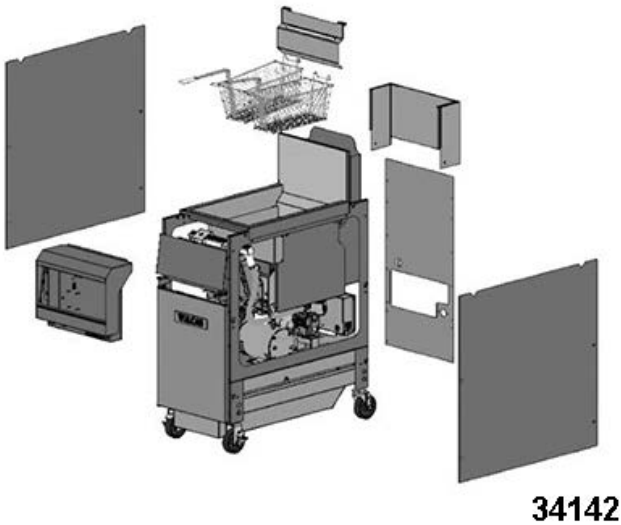

Fig. 46

3. Remove drain manifold (1, Fig. 47) and flange gasket (2, Fig. 47) if fryer has a filter system.



Fig. 47

4. Note and disconnect following wire harness connections.
 - A. DRAIN VALVE SWITCH (D.V.I.) .
 - B. PILOT ASSEMBLY .
 - C. OIL RETURN SOLENOID .
5. Note and remove wire harnesses from harness supports on bottom of fry tank assembly.
6. Disconnect gas lines at burner manifold (1, Fig. 48)

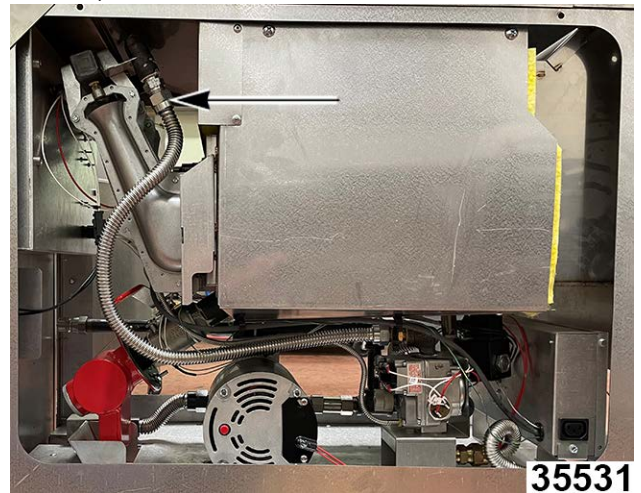

Fig. 48

7. Remove four tank hold-down nuts from tank studs.

NOTE: Two on each side, front (Fig. 49) and back (Fig. 50).



Fig. 49



Fig. 50

NOTE: If working on a two-tank unit, remove back panel and use a 14" extension to reach nut (Fig. 51) between tanks.



Fig. 51

8. Lift tank assembly up and out of chassis frame.
- NOTE:** Tank assembly includes burners, manifold, high limit, temperature probe, drain valve, oil solenoid valve and insulation kit.
9. Remove oil solenoid valve assembly (Fig. 52 and 1 in Fig. 54) and drain valve (Fig. 53 and 2, Fig. 54) from tank and install on new tank using RECTORSEAL 5® or equivalent NSF rated thread sealant.

NOTICE

Note distance from bottom of old drain valve to flange and from top of valve to tank before removing valve to separate flange from valve. The dimensions will need to be duplicated when flange and valve is reinstalled.



Fig. 52

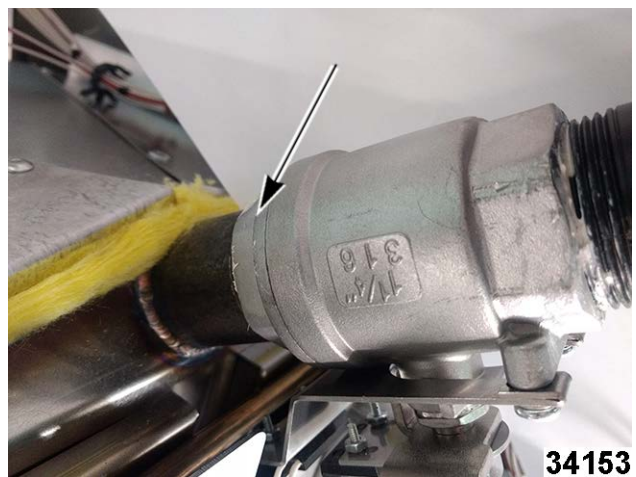

Fig. 53

NOTICE

Note distance from bottom of old drain valve to flange and from top of valve to tank before removing valve to separate flange from valve. The dimensions will need to be duplicated when flange and valve is reinstalled.

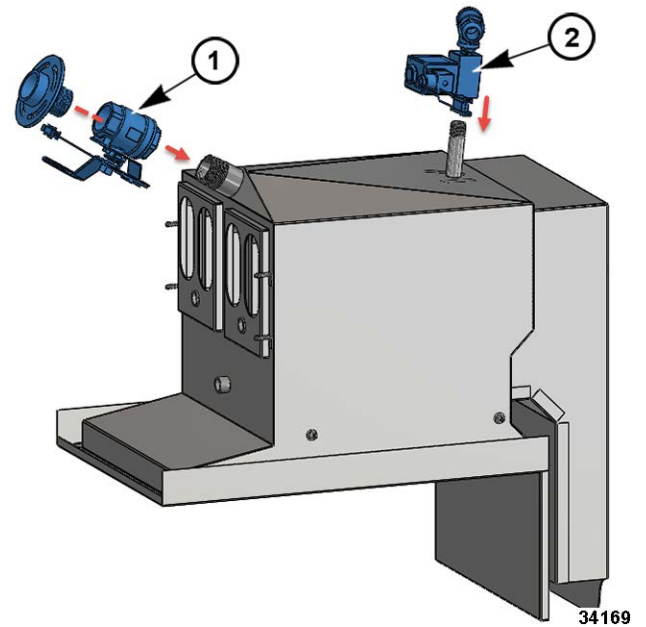

Fig. 54

10. Remove four mounting nuts (Fig. 55) holding burner assembly on tank.

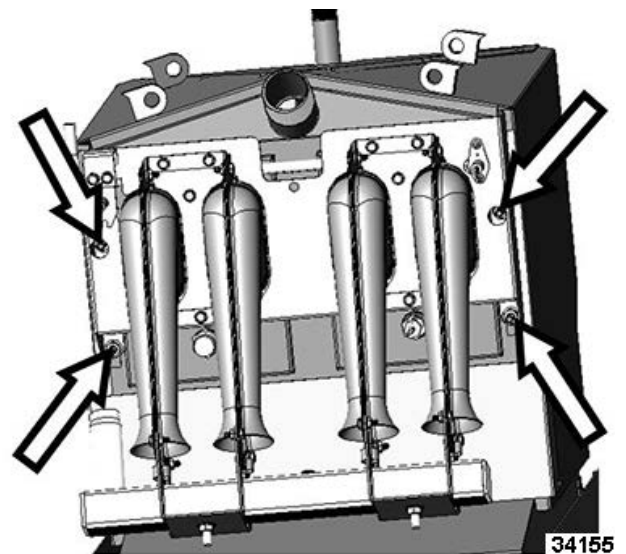

Fig. 55

11. Pull burner assembly off tank studs to remove and install on new tank.
12. Install following parts on new tank.

NOTICE

It is recommended you install new parts on new tank instead of reinstalling old parts.

- A. Install insulation kit (1, in Fig. 56 and Fig. 57) by setting into place and riveting (3/16" blind rivets) sections to itself. Attach kit assembly to tank with four 1/4-20 x 3/8 truss head screws, two on each side.

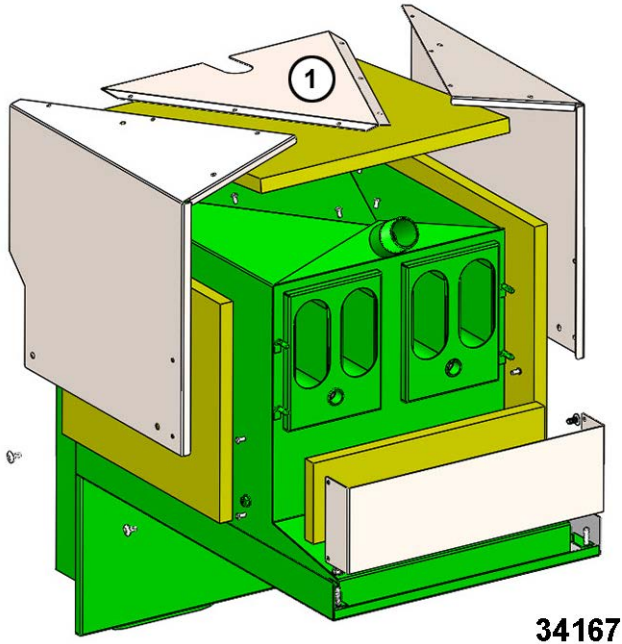

Fig. 56



Fig. 58

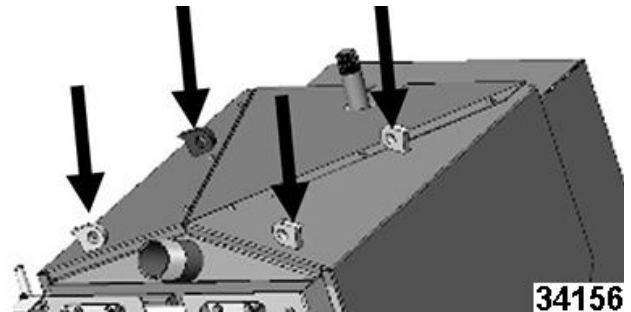

Fig. 59

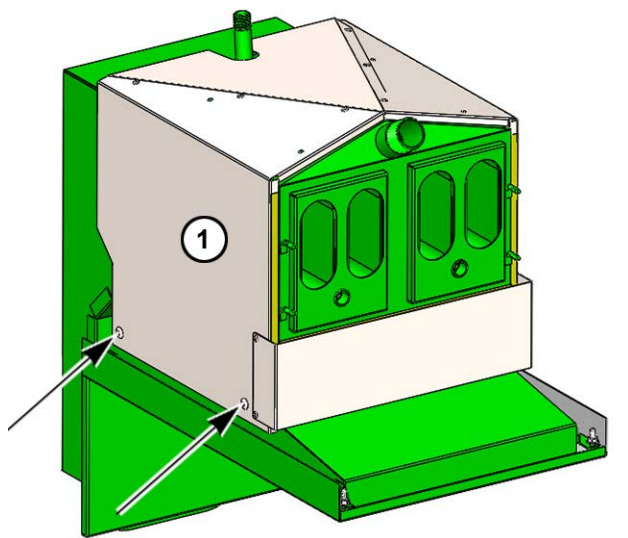

Fig. 57

- B. Four wire assembly support guides.

- C. HIGH LIMIT .
 - D. TEMPERATURE PROBE .
13. Reverse STEP 1 through STEP 9 to complete installation.

NOTICE

Verify drain valve is at same depth on new tank that was measured when removing. This will ensure that the drain manifold will be installable and level.

Note dimension before removing

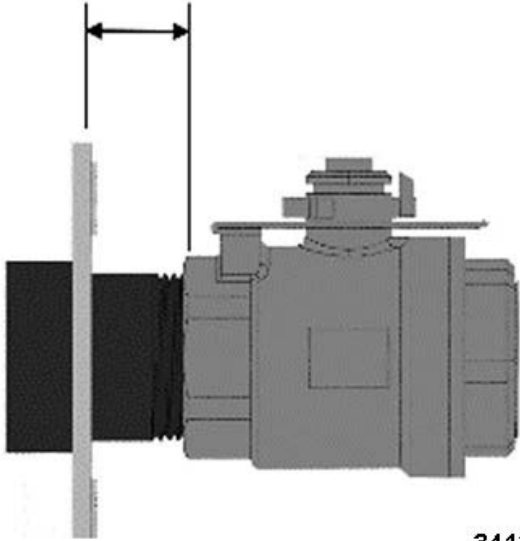

34139

Fig. 60

14. Verify operation.
15. Check for leaks.

SERVICE PROCEDURES AND ADJUSTMENTS

DRAIN OIL

Refer to DRAINING THE TANK for VHG A models in: VHG-A SERIES GAS FRYERS INSTALLATION AND OPERATION.

Refer to DRAINING THE TANK for VHG C-D models in: VHG-C-D SERIES GAS FRYERS INSTALLATION AND OPERATION.

ELECTRIC CONNECTIONS

NOTE: This section applies to the 120V fryer only. 240V version does not come with a power cord and the Ground Fault Circuit Interrupter (GFCI) will not work due to it being rated at 125V only.

The VHG series fryers are supplied with a 120Volt cord and three prong plug. If local electrical codes require that these fryers be plugged into a GFIC. You must use GFI part number 913053. Other GFIC outlets may not have the correct tolerance for the spark to ground ignition system employed with the VHG series fryers.

TEMPERATURE PROBE FAULT CODES

The probe is an RTD (resistance temperature detector) thermistor type. As temperature increases, resistance value decreases.

Probe Fault

If a temperature probe fault or high temperature condition occurs, a fault message will be displayed, and the electronic alarm will sound continuously on D and C controls. The heat demand and basket lift outputs are de-activated. If a cooking cycle is in process (timer active), it will be cancelled.

This will continue until the fault clears, power is cycled, or problem resolved.

A High Temperature condition does not disable the keypad. If someone has their fryer at 350°F (176.6°C) and decides to take it down to 300°F (148.8°C), this will produce the high temp alarm and alarm tone (C & D). Go back into program mode to reset the setpoint on C & D models or turn temperature control knob on A models to bring the control out of the error mode.

CONTROL TYPE	FAULT
D - Digital C - Computer	Open will display PROBE OPEN
	Short will display PROBE SHORT
	High Temperature on D will display HI TEMP High Temperature on C will display HIGH TEMP
A - Solid-state with Knob	Open will display oP
	Short will display SP
	High Temperature will display HI

TEMPERATURE PROBE TEST

CHECK

1. Turn power switch off.
2. Unplug temperature probe at probe/DVI switch 6-pin plug.
3. Test the probe using a VOM to measure resistance. Connect meter leads to temperature probe wires.
 - If measured resistance values are within allowable range, the probe is functioning properly.

NOTE: Recommendation, if still receiving a Probe Fault Code on controller, trace color coded probe wires from 6 and 12 pins of the 12-pin connector all the way to controller. Check resistance across the temperature probe wires directly at controller plug. If resistance does not match, check for loose connections and/or damaged wiring.

- If measured resistance values are outside the allowable range, install a replacement probe and check for proper operation.

TEMPERATURE	RESISTANCE (Ω)
40°F (4.4°C) ³	>268900
77F (25°C)	90,000 - 110,000
350°F (176.6°C)	604 - 836
415°F (212.7°C) ¹	302 - 369
460°F (237.7°C) ²	191 - 233

TEMPERATURE	RESISTANCE (Ω)
<p>1 High temperature alarm level for the cooking controls. 415°F is the max temp before a High Temp alarm is triggered. High Temp alarms also happen when the temperature is greater than 40°F above desired setpoint.</p> <p>2 Shorted probe equivalent temperature</p> <p>3 Control will read OPEN PROBE. Fryers installed in a non-heated kitchen can display this problem for service from time to time.</p>	

4. Reverse procedure to install when probe is functioning properly.
5. Verify operation.

COOKING CONTROL CALIBRATION

NOTICE

Verify condition of temperature probe before proceeding. Refer to: TEMPERATURE PROBE TEST.

1. Check level of shortening in fry tank.

NOTE: The level must be between MIN & MAX fill lines before proceeding.

2. Allow shortening to cool below 300°F (176.6°C).
3. Place a thermocouple in the geometric center of fry tank one inch below shortening surface.
4. Set cooking control to 350°F (176.6°C) and turn fryer on.
5. Monitor heat indicator lamp. When cooking control is calling for heat, lamp will be on. If cooking control is satisfied, lamp will be off.
 - Solid-state with Knob - Heat light is below display window.
 - Digital Control - LED under heat indicator; "HEATING" is displayed.

NOTE: The real indication of control function is the heating LED located along the top of display. Sometimes it says "HEATING" but isn't calling for heat at that moment. When the control is coming up to setpoint it will stop calling for heat early to minimize overshoot. It will say HEATING until the temperature drifts up there the first time. "HEATING" really means "NOT READY TO COOK".

- Computer Control - LED under heat indicator; "HEATING" is displayed.

NOTE: Agitate the shortening, to eliminate any cold zones.

NOTE: The real indication of control function is the heating LED located along the top of display. Sometimes it says "HEATING" but isn't calling for heat at that moment. When the control is coming up to setpoint it will stop calling for heat early to minimize overshoot. It will say HEATING until the temperature drifts up there the first time. "HEATING" really means "NOT READY TO COOK"

- A. Allow cooking control to cycle three times to stabilize shortening temperature.
 - B. Record meter reading from thermocouple when cooking control cycles off and on for at least two complete heating cycles.
6. Calculate the average temperature by adding the temperature reading when the heat lamp goes out to the temperature reading when the heat lamp comes on & divide this answer by 2.

$$[\text{Temp. (Lamp off)} + \text{Temp. (lamp on)}] \div 2 = \text{Average Temp. Example: } 360^\circ + 340^\circ \div 2 = 350^\circ\text{F (} 182.2^\circ\text{C} + 171.1^\circ\text{C} \div 2 = 176.6^\circ\text{C)}.$$

The average temperature should be 350°F (182.2°C) (± 5°F (-15°C)).

- If the average temperature reading is within tolerance, cooking control is properly calibrated.
- If the average temperature reading is out of tolerance, adjust OFFSET TEMPERATURE.

NOTE: Refer to: SERVICE PROGRAMMING to adjust OFFSET TEMPERATURE.

7. Repeat average temperature calculation for up to three attempts. Allow cooking control to cycle at least two times between adjustments before performing the calculation.
8. If calibration is unsuccessful, cooking control may be malfunctioning and cannot be adjusted properly. Install a replacement cooking control and check calibration.

FLAME SENSE CURRENT CHECK



⚠ WARNING

Certain procedures in this section require electrical test or measurements while power is applied to the machine. Exercise extreme caution at all times and follow Arc Flash procedures. If test points are not easily accessible, disconnect power and follow Lockout/Tagout procedures, attach test equipment and reapply power to test.

1. Access PILOT ASSEMBLY (1, Fig. 61).

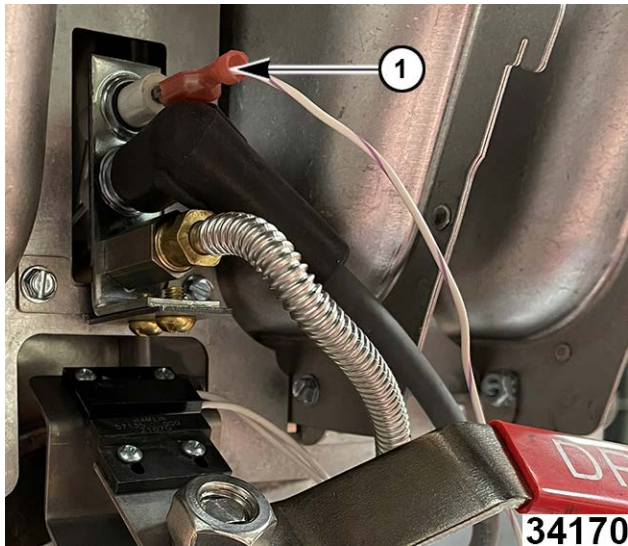

Fig. 61

2. Connect a true RMS or analog DC microammeter in series between the flame sense rod terminal and the flame sense wire terminal.
3. Power up fryer and have it call for heat.
4. Verify a minimum microamp reading of at least 1.0 microamp.

Reading

- Greater or equal to value given, then flame sense current is within tolerance.
- Lower than value given, then troubleshoot flame sense circuit.
- Below 0.0 microamps, reverse meter leads and take another reading.

NOTE: Check flame sense directly at ignition module. A digital voltmeter may be used to measure DC voltage between FC+ and FC- terminals. Each micro-

amp of flame current produces 1.0 VDC. For example, 2.0 VDC equals 2.0 μ A.

ELECTRONIC IGNITION CONTROL

The electronic ignition control monitors the presence of a pilot flame and energizes the main gas valve coil to ignite the burners. When fryer is unable to detect flame sense the electrode will try to ignite one time. When flame has not been detected within 90 seconds, the igniter will stop sparking and will not try again until power switch is cycled.

Ignition Module Lockout

- "A" Style Controller: If pilot does not ignite within 90 seconds, PLt will show in the display window, the ignition module locks out, the heat demand is disabled, and the control locks out.
- "C" and "D" Style Controller: If pilot goes out, **PILOT OUT** will show in display window. If no action is taken after 90 seconds, an alarm sounds continuously, **IGNITION LOCKOUT** will show in display window, the heat demand is disabled, and any running cooking cycles are cancelled.

Electronic Ignition System



⚠ WARNING

Certain procedures in this section require electrical test or measurements while power is applied to the machine. Exercise extreme caution at all times and follow Arc Flash procedures. If test points are not easily accessible, disconnect power and follow Lockout/Tagout procedures, attach test equipment and reapply power to test.

1. Access burner electrode.
2. Verify fry tank is full between max and min lines on back of tank.
3. Turn power switch on.
4. Bypass the Dry Fire Test:
 - A-control: **Press V-Start**
 - D-control: Press **V-PROGRAM**
 - C-control: Press **CONFIRM**
5. Verify function.
 - Look at electrode to verify spark.

- If no spark is seen but can be heard, carefully look along igniter wire for cuts and damage.
- If igniter wire is undamaged, open power box to ensure igniter wire is properly installed onto ignition module.
- Ensure electrode is sparking to pilot burner head.
- Spark gap between electrode and pilot burner head should be 0.120 in. +/- 0.010 in (Fig. 62).

NOTE: A replacement assembly should come with correct gap.

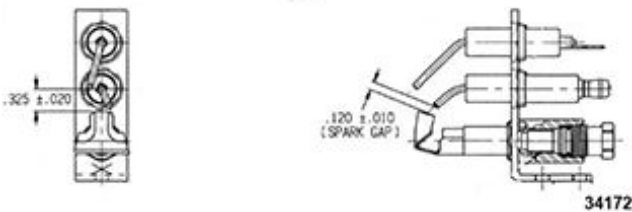

Fig. 62

GAS MANIFOLD PRESSURE ADJUSTMENT



WARNING

Disconnect the electrical power to the machine and follow lockout / tagout procedures.



WARNING

Shut off the gas before servicing the unit and follow lockout / tagout procedures.

NOTICE

Service connection, 1/2" (13mm) ID and 3/4" (19mm) OD rear gas connection for single units and 1-1/4"(31.75mm) for battery units.

1. Open the door(s) and turn the gas combination valve off (1, Fig. 63).
2. To measure the manifold pressure, remove the 1/8-inch NPT plug (pressure tap) on the burner gas manifold and attach a manometer.
3. Turn the gas supply, gas combination valve and the main power switch to on.

NOTE: Verify burners light.

4. Observe the manometer pressure reading and compare to the pressure chart near the end of this procedure.
 - If other appliances are connected to the same gas line, turn them all on and check manometer pressure reading again. If a pressure drops of 1/2 inch water column or more is observed, then gas supply needs to be checked by the gas line installer or local gas company for adequate sizing.
 - If adjustment is necessary, continue with procedure.
5. Remove adjustment screw cover (2, Fig. 63) to access pressure adjustment screw.
 - To increase pressure, turn the screw clockwise.
 - To decrease pressure, turn the screw counterclockwise.

NOTE: Accurate gas pressure adjustments can only be made with gas on and burner lit.

6. Set pressure as outlined below:

Gas Type	PRESSURE READINGS			
	Manifold	Line		
		Recommended	Min.	Max.
Natural	3.5 W.C.	7 W.C.	6 W.C.	14 W.C.
Propane	10 W.C.	11 W.C.	11 W.C.	14 W.C.

NOTE: If incoming line pressure is less than minimum stated, then manifold pressure cannot be set correctly.

7. Once the correct pressure has been set, turn power switch off, replace adjustment screw cap and 1/8" NPT plug (pressure tap) on the outlet side of valve.
8. Check for proper operation and adjust if necessary.

PILOT ADJUSTMENT

- A. Remove gas valve pilot adjustment cover (3, Fig. 63) to expose adjustment screw.
- B. Adjust flow with pilot lit. The flame sensor should be surrounded (engulfed) by as much of the outer cone of the pilot flame as practical, allowing maximum current (micro-amp) flow.
- C. Turn pilot adjustment.
 - Clockwise decreases pilot flow.

- Counterclockwise increases pilot flow.

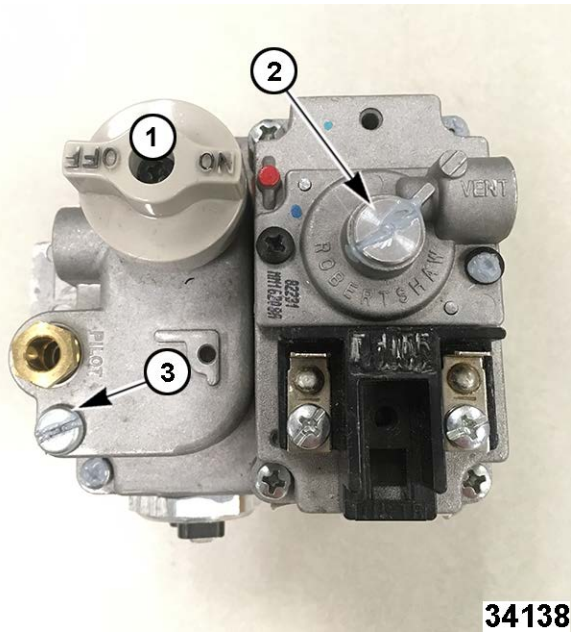

Fig. 63

GAS VALVE

- 1) ON/OFF Knob
- 2) Gas Pressure Adjustment Screw Cover
- 3) Pilot Adjustment Screw Cover

⚠ WARNING

All gas joints disturbed during servicing must be checked for leaks. Check with a soap and water solution (bubbles). Do not use an open flame.

SERVICE PROGRAMMING

VHG A CONTROL SERVICE PROGRAMMING

1. Enter service mode. (Fig. 64)
 - A. Simultaneously press and hold **START** and **MELT** buttons for 3-5 seconds until "At" displays (may also show PF, Er or CEF).
 - B. Select "At" (for atmospheric burners) only for VHG Series model fryers.
 - C. Remaining options to be used for different fryer models. Turning the knob cycles through the options for each service setting.
 - D. Press **START** button when finished to move on to next service setting.



Fig. 64

2. **VAt** will display and vat size setting will toggle back forth. (Fig. 65)
 - Select either **50** (if 4 burners per vat) or **75** (if 6 burners per vat) for the vat size on VHG models.

NOTE: The remaining options are to be used for different fryer models.



Fig. 65

3. **oFS** will display and **offset** setting will toggle back forth. (Fig. 65)
 - A. Select **desired temperature** offset setting.
 - B. Select **0** if unsure of previous offset setting.



Fig. 66

4. **FLt** will display and **oFF** or **on** setting will toggle back and forth. (Fig. 67)
 - Select **on** if the fryer has a built-in oil filtration system or **oFF** if it does not.



Fig. 67

5. **F** or **C** will display.
 - Select **F** for Fahrenheit temperature scale or **C** for Celsius.



Fig. 68

6. **dF** will display and **OFF** or **on** setting will toggle back and forth. (Fig. 69)
 - Turn Dry Fire Test **off** or **on** with this setting.
7. Press **START** button to exit service settings mode and normal operation will begin.



Fig. 69

VHG C CONTROL SERVICE PROGRAMMING

1. Enter service mode.
 - A. Cycle power switch.
 - B. Press **PROGRAM** when VULCAN FRYER (Fig. 70) appears on the screen for the second time and **SERVICE MODE** (Fig. 71) will appear.

NOTE: Lights over the buttons with service setting functions will illuminate.



Fig. 70



Fig. 71

2. Select service setting being checked or changed.
 - A. Press **UP** and **DOWN** arrows on **PROGRAM** button to cycle through each setting.
 - B. Press **CONFIRM** to save change or **CANCEL** button to exit without saving setpoint change.

BUTTON LEGEND (LEFT TO RIGHT)	
1.	Keypad configuration.
2.	Temperature scale.
3.	Filter mode.
4.	Fryer type and vat size.
5.	Temperature offset.
6.	Basket lift.
7.	Recovery type.
8.	Oil level probe enable.
9.	Diagnostic mode.
17.	Copy factory settings from USB.
18.	Copy factory settings to USB.

1. **CONFIG** will display. Select the keypad configuration to match the overlay (Fig. 72) represents the 1-9 1-9. The configuration numbered buttons are arranged in two sections of 1-9.



Fig. 72

2. **TEMP SCALE** will display (Fig. 73). Select **Fahrenheit** or **Celsius** temperature scale.



Fig. 73

3. **MODE** will display. Select **FILTER** if the fryer has a built-in oil filtration system or **NON-FILTER** if it does not.



Fig. 74

4. **FRYER TYPE** will display. Remaining options are to be used for different fryer models.
 - A. Only select **AT** (for atmospheric burners) for the VHG Series model fryers. Remaining options are to be used for different fryer models. (Fig. 75)

- B. Press **CONFIRM** button once the correct **FRYER TYPE** is displayed.
- C. **VAT SIZE?** will display. Only select either **50 (4 burners per vat)** or **75 (6 burners per vat)** for vat size on VHG models. (Fig. 76)
- D. Remaining options are to be used for different fryer models.

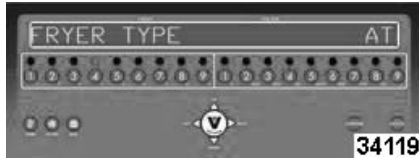

Fig. 75



Fig. 76

- 5. **TEMP OFFSET** will display.
 - A. Select desired temperature offset setting.
 - B. Select **0F** if unsure of previous offset setting.

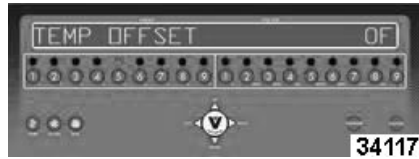

Fig. 77

- 6. **BASKET LIFTS** will display. Select **0** if there are no automatic basket lifts or 1-2 for the number of automatic basket lifts per vat.



Fig. 78

- 7. **RECOVERY** will display.

NOTE: This feature is not currently used and is not a changeable service option.

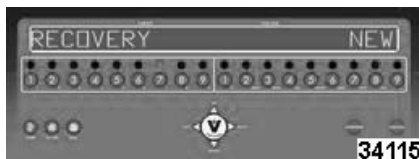

Fig. 79

- 8. **LEVEL PROBE ENABLE.**

NOTE: This feature is not currently used and should be set to **NO**.



Fig. 80

- 9. **DIAGNOSTIC MODE** will display. The lights over the buttons with diagnostics functions will illuminate.

- A. Go to the function you wish to check by pressing corresponding button.
- B. Pressing **CONFIRM** or **CANCEL BUTTON** will allow you to return to diagnostic menu and make another selection.
 - **LEFT BASKET** Toggling the 1 button moves the left basket lift (if applicable) up and down.
 - **RIGHT BASKET** Toggling the 2 button moves the right basket lift (if applicable) up and down.
 - **HEATER** Toggling the 3 button turns the heating function off and on.
 - **FILTER PUMP** Toggling the 4 button turns the filter pump (if applicable) off and on.
 - **DRAIN SWITCH** Indicates the drain switch status by toggling either CLOSED or OPEN on the display.
 - **LED Test** Tests controller LEDs by illuminating all simultaneously.
 - **VAT TEMP** – Displays the current vat temperature.



Fig. 81

- 10. Pressing **CANCEL** button twice or pressing **CANCEL** button after **CONFIRM** button will return to service mode.
- 11. Pressing **PROGRAM** button after **CONFIRM** or **CANCEL** button exits service mode and normal operations will begin.
- 12. **COPY FACTORY FROM USB?** will display by pressing **17 button** while in service mode.

NOTE: This uploads control configuration from USB.

- A. Insert USB into USB port.

NOTE: USB needs to have factory configuration files saved in top level of USB drive before inserting.

- B. Press the **CONFIRM** button.
- C. Control displays **WORKING** and then **USB COPYING COMPLETED**.



Fig. 82

- 13. **COPY FACTORY TO USB?** will display by pressing **18 button (far right)** while in service mode. This will download original factory control configuration to a USB.

- A. Insert USB into USB port.
- B. Press the **CONFIRM** button.
- C. Control displays **WORKING** and then **USB COPYING COMPLETED**.



Fig. 83

VHG D CONTROL SERVICE PROGRAMMING

- 1. Enter service mode.
 - A. Cycle power switch.
 - B. Press **PROGRAM** button when **VULCAN** first appears on screen.



Fig. 84

- 2. **TEMP** will display.
 - A. Select **F** for Fahrenheit temperature scale or **C** for Celsius.
 - B. Pressing **UP** and **DOWN** arrows of the **PROGRAM** button cycles through the options for each service setting.

- C. Press **PROGRAM** button when finished to move on to the next service setting.

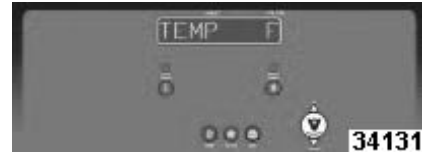

Fig. 85

- 3. **FILT?** will display. Select **Y** if fryer has a built-in oil filtration system or **N** if it does not.



Fig. 86

- 4. **TYPE** will display. Only select **AT** (for atmospheric burners) for the VHG Series model fryers. Remaining options are to be used for different fryer models.



Fig. 87

- 5. **VSIZE** will display. Select **50** (4 burners per vat) or **75** (6 burners per vat) for the vat size on VHG models. Remaining options are to be used for different fryer models.



Fig. 88

- 6. **OFS** will display. Select desired temperature offset setting. Select **0F** if unsure of previous offset setting.



Fig. 89

- 7. **BASKET** will display. Select **0** if there are no automatic basket lifts or **1-2** for the number of automatic basket lifts per vat.



Fig. 90

8. **DIAGMODE** will display.

NOTE: Diagnostics mode is the last service setting feature.

9. Cycle through diagnostics mode options with **PROGRAM** button. Each diagnostic function can be tested by pressing **UP** or **DOWN** arrows of the **PROGRAM** button.

- **D-BASK L** Test the left automatic basket lift function.
- **D-BASK R** Test the right automatic basket lift function.
- **D-HEAT** Test the heating function.
- **D-FILTER** Test filtering- pump motor function
- **D-DRAIN** Indicates the drain switch status by toggling either **CLOSED** or **OPEN** on the display.



Fig. 91

NOTE: Pressing the **PROGRAM BUTTON** again exits diagnostics mode and normal operation will begin.

ELECTRICAL OPERATION

COMPONENT FUNCTION

Igniter	Ignites the pilot burner.
Ignition Control Module	Controls and monitors gas pilot ignition. Energizes pilot valve coil on the combination control valve and generates spark for pilot ignition. Monitors the presence of a flame and supplies an ignition status input signal to the cooking control
Analog (A), Solid State (D) or Computer Cooking Control C) ...	Monitors and evaluates input signals to the control: Activates heat output signal to maintain shortening temperature; counts product cook time(s) and signals the electronic alarm at the end of a cooking cycle (D and C only); activates the left and right lift output signal to operate the basket lifts(s) (D and C only); and activates filter output signal to power the fill solenoid valve. NOTE: By utilizing the same wiring harness connections A, D and C controls are interchangeable between fryers. However, A-control requires specific sheet metal to be properly mounted.
Control Interface Board	There are two different interface boards. One is the standard model which has a heat control Triac and K1 N.O. relay for the filter pump. The other optional interface board is for basket lift equipped fryers and has a heat control Triac and K1, K2, & K3 N.O. relays.
Transformer	Supplies 24VAC to the cooking control, also supplies power to ignition control module. Transformer is energized when power switch is turned on.
Power Switch	Supplies power to control circuit for fryer operation and filtering.
Gas Combination Valve	Allows gas flow to the pilot when pilot valve coil is energized; and gas flow to the burners when main valve coil is energized. Also, regulates the gas manifold pressure.
High Limit Thermostat	Prevents the shortening from reaching temperatures over 450°F (232.2°C) (auto reset @ 415°F (212.7°C). Serves as a backup to the cooking control's high temperature alarm setting of 415°F (212.7°C) or more than 40°F (4.4°C) over setpoint, whichever occurs first (normal operation resumes when temperature falls below this point).
Temperature Probe ...	Senses temperature of shortening. Converts the temperature into a resistance valve which is monitored by the cooking control. The probe is an RTD (resistance temperature detector) of the Thermistor type. As temperature increases the resistance value decreases.
Drain Valve Interlock Switch (DVI)	A magnetic reed switch mounted on the manual drain valve that supplies a drain valve position signal (open/closed) to the cooking control. When drain valve is open, the drain interlock input to the control is removed (magnetic reed switch contacts open). This prevents gas burners from coming on with the fry tank empty.
Flame Sensor	The flame presence conducts and rectifies a micro amp flame sense current that is detected by the ignition control module.

COMPONENT FUNCTION - KLEENSCREEN FILTER CONTROLS

Fill Solenoid Valve	When energized by the filter key, the solenoid valve opens to allow flow of shortening to return to the tank. When disabled by the oil discard switch, the solenoid valve remains closed when the filter key is energized to allow 100% of oil flow to be discarded through the oil wand or by the optional rear oil discard port.
Pump Motor	Operates pump to circulate shortening through filtering system.

- R1 Pump Motor Relay** When 24VAC relay coil is energized by filter key, supplies 120VAC to pump motor; and fill solenoid valve (thru R2 fill relay N.C. contacts).
- R2 Fill Relay** When 24VAC relay coil is energized by filter key, supplies 120VAC to the fill solenoid valve to open the valve and allow shortening to flow thru filter system.
- Oil Discard Switch** When activated, the oil discard switch disables the fill solenoid valve from opening to prevent oil from flowing back to the tank. This feature requires the oil wand to be connected to the front oil quick disconnect or a rear oil discard system connected to the optional rear oil discard quick disconnect.

COMPONENT LOCATION

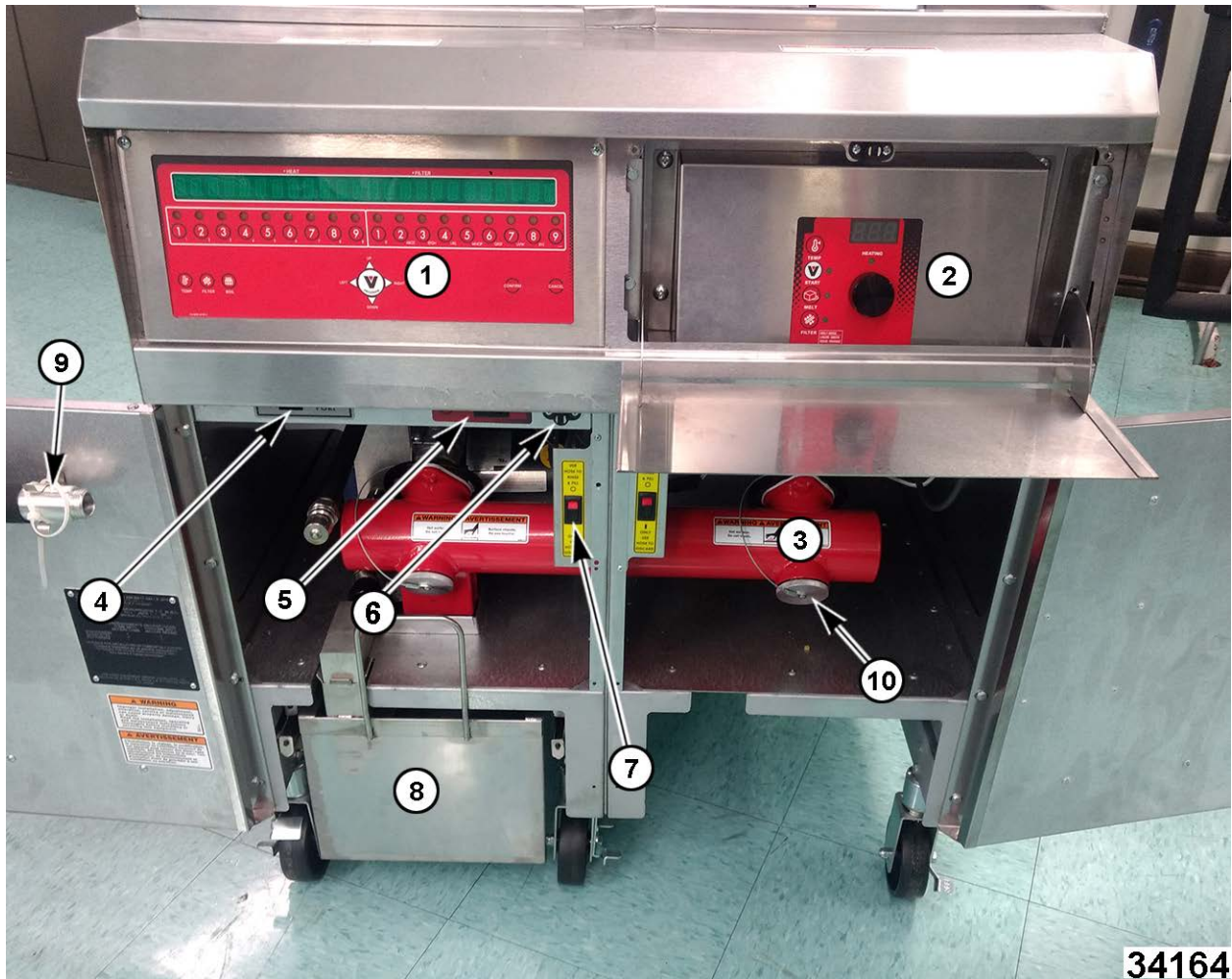

34164

Fig. 92

- Fig. 92**
- | | |
|-------------------------|---------------------------------|
| 1. C & D Control Panel | 6. Door Push Magnet |
| 2. Analog Control Panel | 7. Filter Rinse/Discard Switch |
| 3. Drain Manifold | 8. KleenScreen Filter Pan |
| 4. USB Port | 9. Boil-Out By-Pass Pipe |
| 5. On/Off Switch | 10. Boil-Out By-Pass Drain Plug |

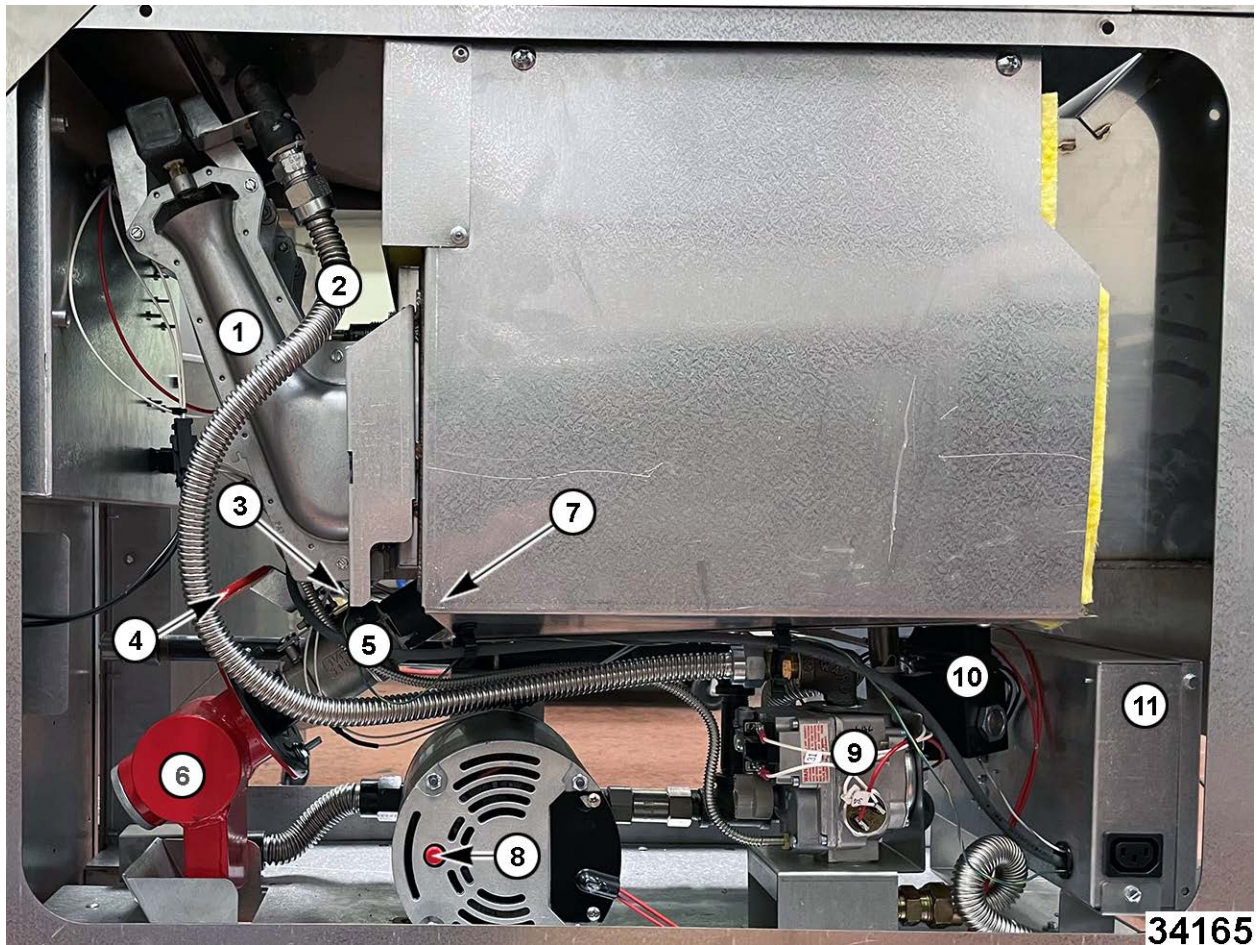

Fig. 93

Fig. 93

- | | |
|-------------------------|---|
| 1. Burner Assembly | 6. Drain Manifold |
| 2. Gas Line | 7. Pilot Orifice |
| 3. Pilot Assembly | 8. Filter Pump Motor (arrow pointing at reset button) |
| 4. Drain Valve Handle | 9. Gas Combination Valve |
| 5. Drain Valve Assembly | 10. Oil Return Solenoid Valve |
| | 11. Power Box |

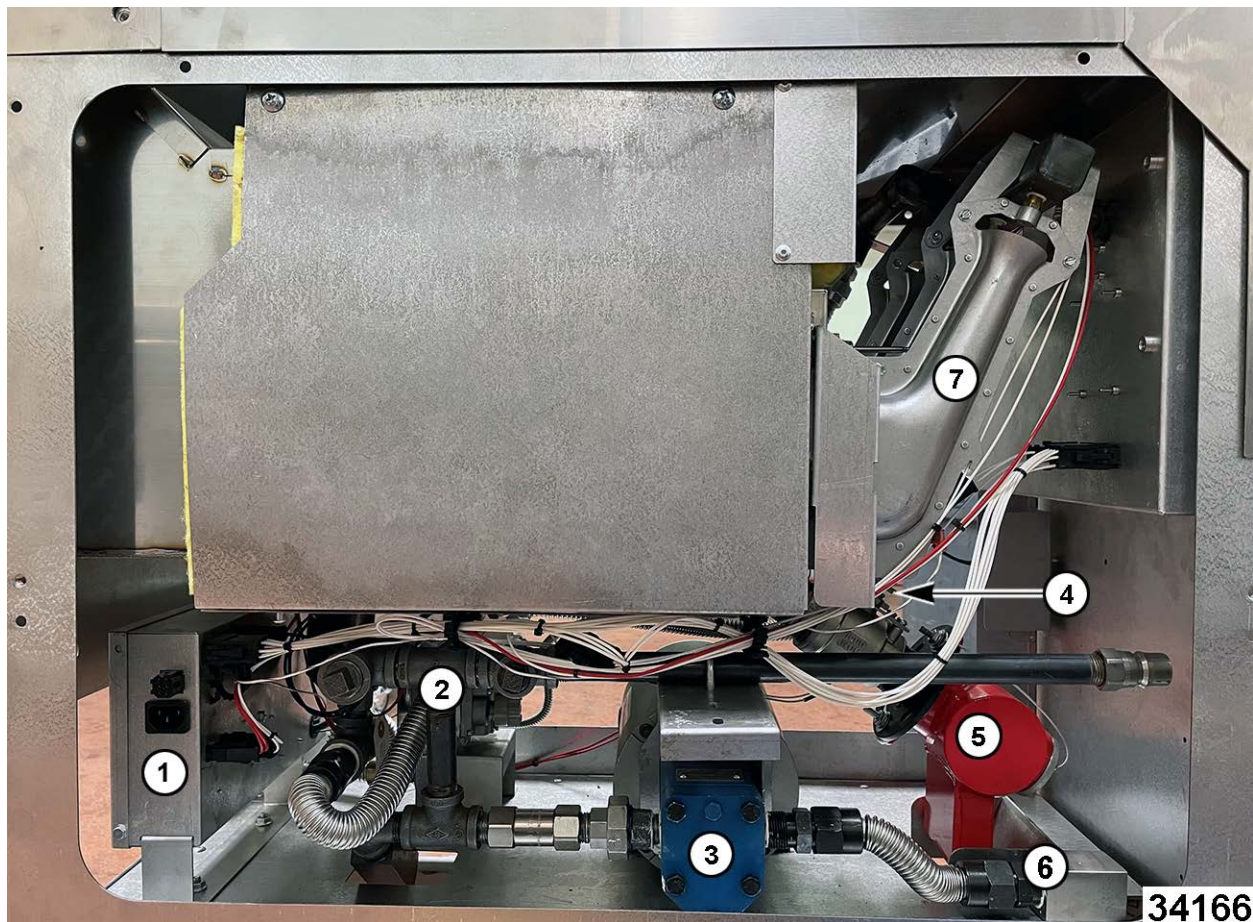

Fig. 94

Fig. 94

1. Power Box
2. Oil Return Piping
3. Pump Assembly and Motor
4. Flame Sense
5. Drain Manifold
6. KleenScreen Suction Tube and Suction Block
7. Burner Assembly

- E. Manual drain valve is closed (drain valve switch N.O. is closed).
- F. Cooking oil/shortening is at proper level in fry tank and is between 300°F (148.8°C) (minimum) and 350°F (176.6°C) (maximum).
- G. 120 VAC to N.O. P2 and P6 of pump motor relay.
- H. Discard switch is set to USE HOSE TO RINSE & FILL.

SEQUENCE OF OPERATION VHG FILTERING

1. Conditions.
 - A. Fryer connected to correct supply voltage and properly grounded.
 - B. Gas supply is on.
 - C. Power switch is ON.
 - D. Cooking control is set up properly and ready to use.

NOTICE

Shortening should not be allowed to filter outside of the 300°F (148.8°C) - 350°F (176.6°C) temperature range. At lower temperatures, the shortening is thicker which may increase filtering time and place a greater load on the pump. At higher temperatures, oil seal life is decreased.

2. Open drain valve to fryer section in need of filtering and drain shortening into the filter pan.
 - A. Drain valve interlock switch contacts open breaking the 24VAC signal input on the cooking controller P8 12-pin connector.

- B. Cooking controller indicates C & D: DRAINING, A: drn, stops heating and normal operations.
3. Press the filter button and hold for approximately 3 seconds.
 - A. 24VDC output from P10 on controller 12-pin to P6 of the interface board.
 - B. Interface board supplies 24VAC output from P1 to the coil of the pump motor relay.
 - 1) Both sets of NO contacts on the pump motor relay close. 120 VAC passed from the P4 pump motor relay thru NC contacts of solenoid fill valve relay to the solenoid fill valve.
 - 2) The NC solenoid fill valve opens.
 - a. 120/240VAC is passed from the other pump motor relay contact (P8) to the pump motor (P1).
 - b. The pump motor starts and shortening circulates through the system.
4. When filtering is complete, close the drain valve and allow the fry tank to refill.
 - A. Drain valve interlock switch contacts close to send 24VAC signal input to the cooking controller P8 of 12-pin connector.
 - B. The controller displays:
 - A control: FILL VAt PrESS FILtEr
 - D control: FILLING PUSH FLT
 - C control: FILLING PRESS FILTER
5. When fry tank is full, press the filter button.
 - A. 24VDC output is removed from P10 on controller 12-pin to P6 of the interface board.
 - B. The interface board stops the 24VAC output from P1 to the coil on the pump motor relay.
 - C. Both sets of NO contacts on the pump motor relay open.
 - 1) 120/240VAC stops from pump motor relay thru NC contacts of solenoid fill valve relay to the solenoid fill valve.
 - 2) The NC solenoid fill valve closes.
 - 3) 120 VAC is stopped from the other pump motor relay contact to the pump motor.
 - 4) The pump motor stops.

- 5) Cooking controller displays:
 - A control: VAt FULL? PrESS StArt
 - D control: VAT FULL? PUSH V
 - C control: VAT FULL? PUSH CONFIRM
6. Confirm the oil is at the proper level between the MIN and MAX marks on the fry tank. Press the Start Button (A-control), the V Button (D-control), or the CONFIRM Button (C-control) to resume normal operation.

SEQUENCE OF OPERATION VHG HEATING

1. Conditions.
 - A. Fryer connected to correct supply voltage and properly grounded.
 - B. Gas supply is on.
 - C. Cooking oil/shortening is at proper level in fry tank and below last set temperature.
 - D. Cooking control is set up properly and ready to use.
 - E. Manual drain valve is closed (drain valve switch N.O. is closed).
 - F. High limit thermostat is closed.
 - G. 120VAC (hot) when plugged in.
 - 1) Basket Lift Connector P4, Basket Lift Relay Switch P5 (if applicable).
2. Power switch turned ON and 120VAC circuit completed through.
 - A. P1 coil terminal on basket lift relay (if applicable) (neutral).
 - B. Transformer P1 (C1-1).
3. Transformer energized and sends out 24VAC to:
 - A. P2 (G2-2) on the interface board for relay power.
 - B. P11 on the interface board for heat triac power.
 - C. Drain switch through to P8 (E1-8) on controller 12-pin connector for drain status.
 - D. P1 (E1-1) on controller 12-pin connector for main controller power.
4. Cooking control powers on, initializes and performs a diagnostic self-check.

5. Cooking control evaluates input signals from the drain switch and temperature probe.
 - A. If drain is closed with 24VAC supplied in to P8(12-pin), temperature probe resistance value into P6/P12(12-pin) matches a call for heat, the Start (A control), V (D control) or CONFIRM (C control) button is pressed and/or the dry fire test is activated/passed;
 - 1) Cooking control sends 24VDC out P4(12-pin) into P9 of interface board.
 6. Interface board sends 24VAC out P12 to TH/W on the ignition module.
 7. Ignition module generates spark at igniter electrode.
 - A. 24VAC sent out V1/PV1 terminal to COM terminal on high limit, through high limit to the + terminal on the gas valve pilot coil.
 - 1) Pilot valve opens and gas flows to the pilot.
 - 2) Pilot flame is established. A micro amp current is rectified to ignition module through the flame sensor and sparking stops.
 8. If pilot flame is not established in 7 seconds, PILOT OUT (D & C controls only) displays, and ignition module continues to spark. If pilot flame is not established after 90 seconds displays;
 - A-control: PLt D-control; IGNITION LOCKOUT.
 - C-control: IGNITION LOCKOUT
 - D & C controls make a steady alarm tone indicating failure.

The ignition module then stops sparking, locks out and the power switch must be cycled to start over at [Step 2](#).
 9. If pilot flame is established.
 - A. 24VAC sent out from IND/MV1 terminal of ignition module to P2(12-pin) ignition status input of cooking controller and TH terminal of gas valve.
 - B. The cooking controller displays:
 - A-control: Displays temperature setpoint and Heating indicator illuminated.
 - D-control: HEATING displayed and Heating indicator illuminated.
 - C-control: HEATING displayed and Heating indicator illuminated.
 - C. Gas flows to burners and the burners ignite from the established pilot flame.
 - D. If a melt mode is programmed and shortening is at or below 135 F, the controller will display:
 - A-control: Melt indicator will flash to indicate active melt mode. If Melt is toggled, Melt briefly displays "S" for Solid, "L" for Liquid, and "no" for No Melt.
 - D-control: Control displays "MELT S" for solid melt mode, "MELT L" for liquid melt mode, and "HEATING" for melt mode off.
 - C-control: Control displays "MELT SOLID" for solid melt mode, "MELT LIQUID" for liquid melt mode, and "HEATING" for melt mode none.

and the sequence starts over at [STEP 5. A. 1](#). The voltage to ignition module TH/W terminal will cycle on and off until the temperature exceeds 135°F (57.2°C).

Melt mode in VHG functions with these times:

 - Solid:
 - 8 seconds heat on.
 - 26 seconds heat off.
 - Liquid:
 - 16 seconds heat on.
 - 18 seconds heat off.
- NOTE:** The heat on timers start when the control receives flame prove signal.
10. Cooking control continues to evaluate input signals from the ignition module, drain switch and temperature probe.
 - A. Burner heats shortening in fry tank.
 11. Shortening reaches setpoint temperature.
 - A. Cooking control removes 24VDC output from P4(12-pin) to interface board P9.
 - B. Interface board removes 24VAC output from P12 to TH/W on the ignition module.
 - C. Ignition module removes 24VAC output from V1/PV1 terminal to COM terminal on high limit, through the high limit to the + terminal on the gas valve pilot coil.
 - 1) Gas flow stops through gas valve pilot and pilot goes out.

D. Ignition module removes 24VAC output from IND/MV1 terminal of ignition module to P2(12-pin) ignition status input of cooking controller and TH terminal of gas valve.

12. When Cooking control calls for heat, sequence begins again at STEP 5.1.A.

- 1) Gas flow stops to burner and burner goes out.

SCHEMATICS

VHG Schematics 11 x 17

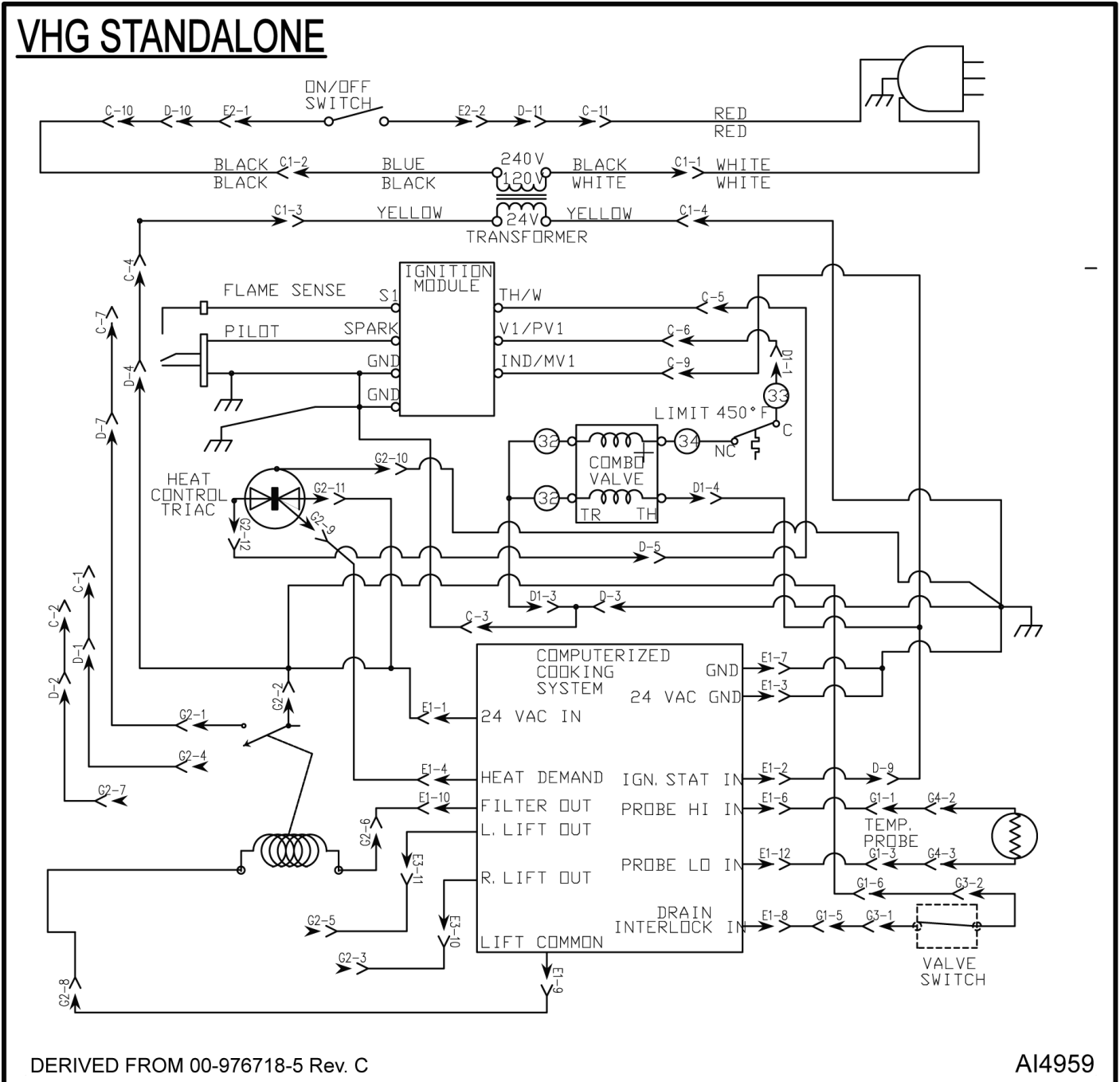

Fig. 95

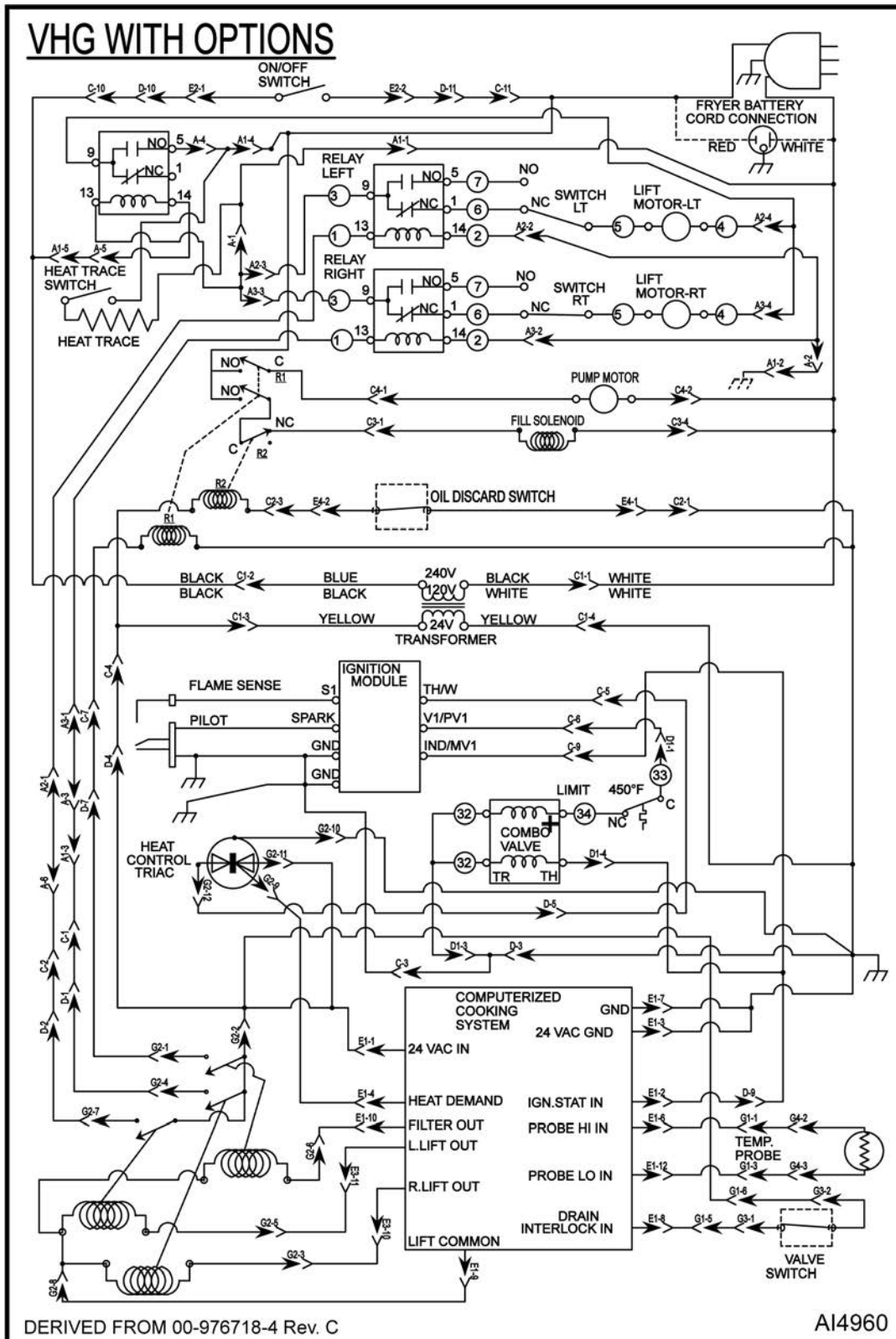
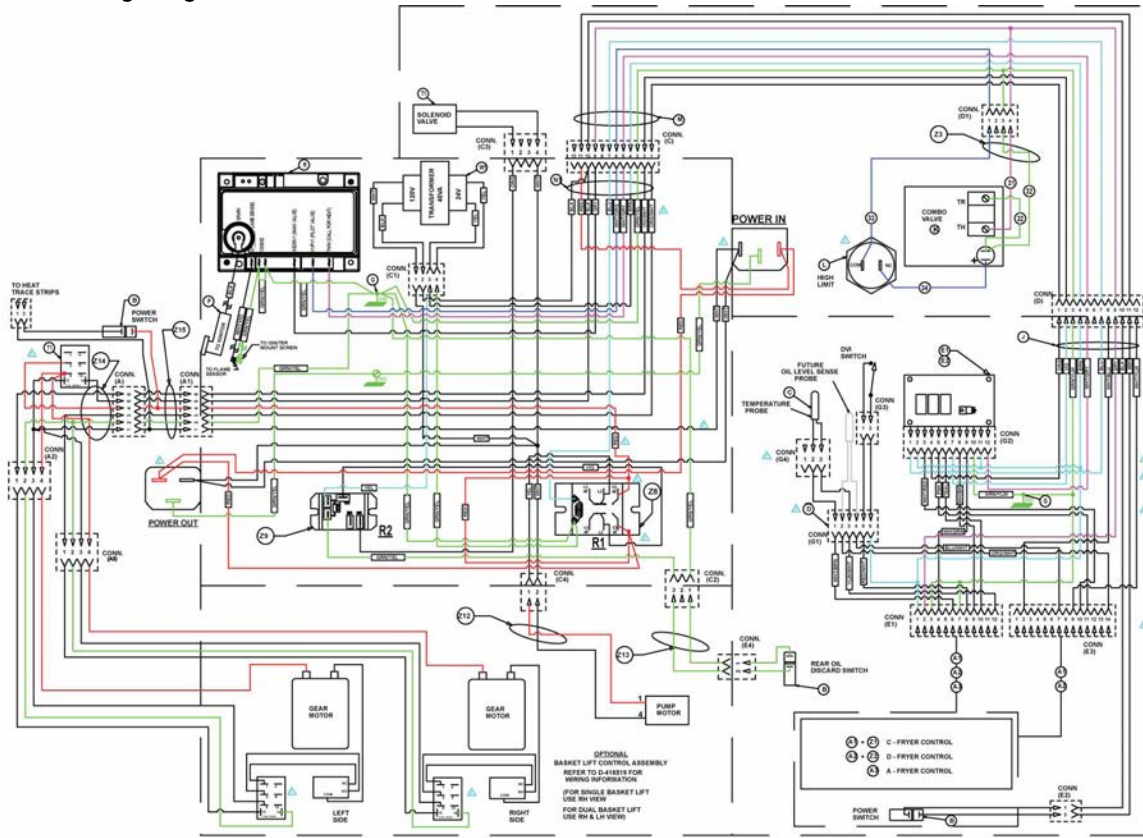

Fig. 96

WIRING DIAGRAMS

VHG Wiring Diagrams 11 x 17



**WIRING DIAGRAM, VHG FRYER
OPTION HARNESS, 120VAC
Refer to Schematic 976718-4
Derived From 97618-1 Rev G**

A14961

Fig. 97

VHG 120 VAC WIRING DIAGRAM WITH OPTIONS 120 VAC	
ITEM	DESCRIPTION
A1	C-CONTROL
A2	D-CONTROL
A3	A-CONTROL
Z1	HARNESS, CONNECTOR, C-CONTROL
Z2	HARNESS, CONNECTOR, D-CONTROL
B	ROCKER SWITCH ASSEMBLY
C	VHG THERMISTOR PROBE
D	HARNESS, DVI, VHG
E1	INTERFACE BOARD W/ BASKET LIFT
E2	INTERFACE BOARD W/ O BASKET LIFT
G	TERMINIAL, STATIONARY
J	INTERFACE HARNESS
K	COMBO VALVE
L	HI-LIMIT, FENWAL

VHG 120 VAC WIRING DIAGRAM WITH OPTIONS 120 VAC	
ITEM	DESCRIPTION
M	MAIN HARNESS
N1	HARNESS, POWER BOX, OPTION
P	IGNITER CABLE
R	IGNITER MODULE
T1	SWITCH, RELAY 120V
W1	HARNESS, TRANS., 40VA, 120V/24V
Z3	HARNESS, VALVE, GAS
Z8	RELAY 1 HP 120 VOLT
Z9	RELAY SPST 245 VAC COIL
Z12	HARNESS, MOTOR, PUMP, VHG
Z13	HARNESS, FILTER, SWITCH
Z14	HARNESS, BASKET LIFT
Z15	HARNESS, HEAT TRACE

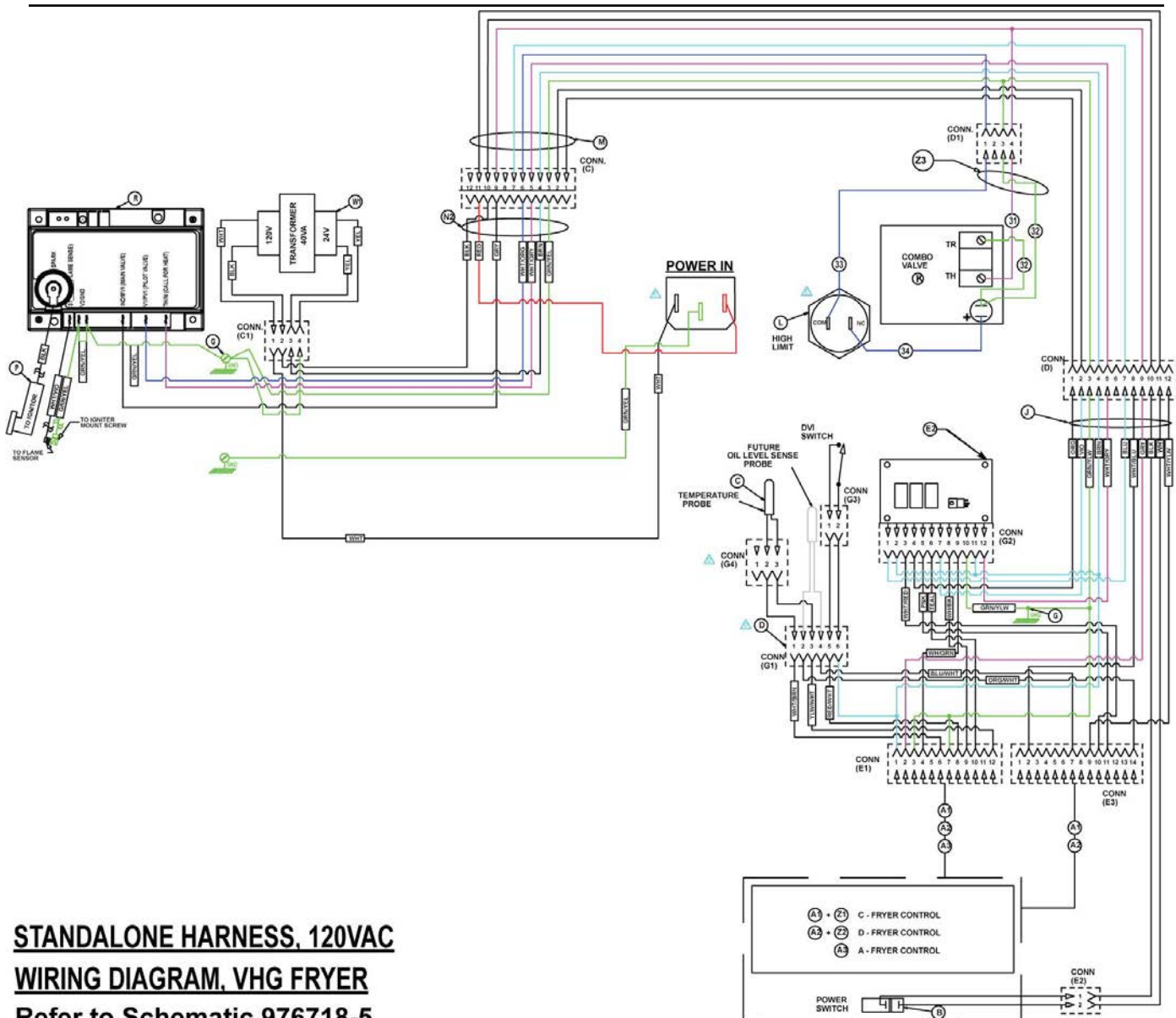

STANDALONE HARNESS, 120VAC

WIRING DIAGRAM, VHG FRYER

Refer to Schematic 976718-5
Derived From 97618-1 Rev G

AI4962

Fig. 98

VHG 120 VAC WIRING DIAGRAM STAND ALONE HARNESS 120 VAC	
ITEM	DESCRIPTION
A1	C-CONTROL
A2	D-CONTROL
A3	A-CONTROL
Z1	HARNESS, CONNECTOR, C-CONTROL
Z2	HARNESS, CONNECTOR, D-CONTROL
B	ROCKER SWITCH ASSEMBLY
C	VHG THERMISTOR PROBE
D	HARNESS, DVI, VHG
E2	INTERFACE BOARD W/ O BASKET LIFT
G	TERMINIAL, STATIONARY
J	INTERFACE HARNESS
K	COMBO VALVE

VHG 120 VAC WIRING DIAGRAM STAND ALONE HARNESS 120 VAC	
ITEM	DESCRIPTION
L	HI-LIMIT, FENWAL
M	MAIN HARNESS
N2	HARNESS, POWER BOX, STANDALONE
P	IGNITER CABLE
R	IGNITER MODULE
W1	HARNESS, TRANS., 40VA, 120V/24V
Z3	HARNESS, VALVE, GAS

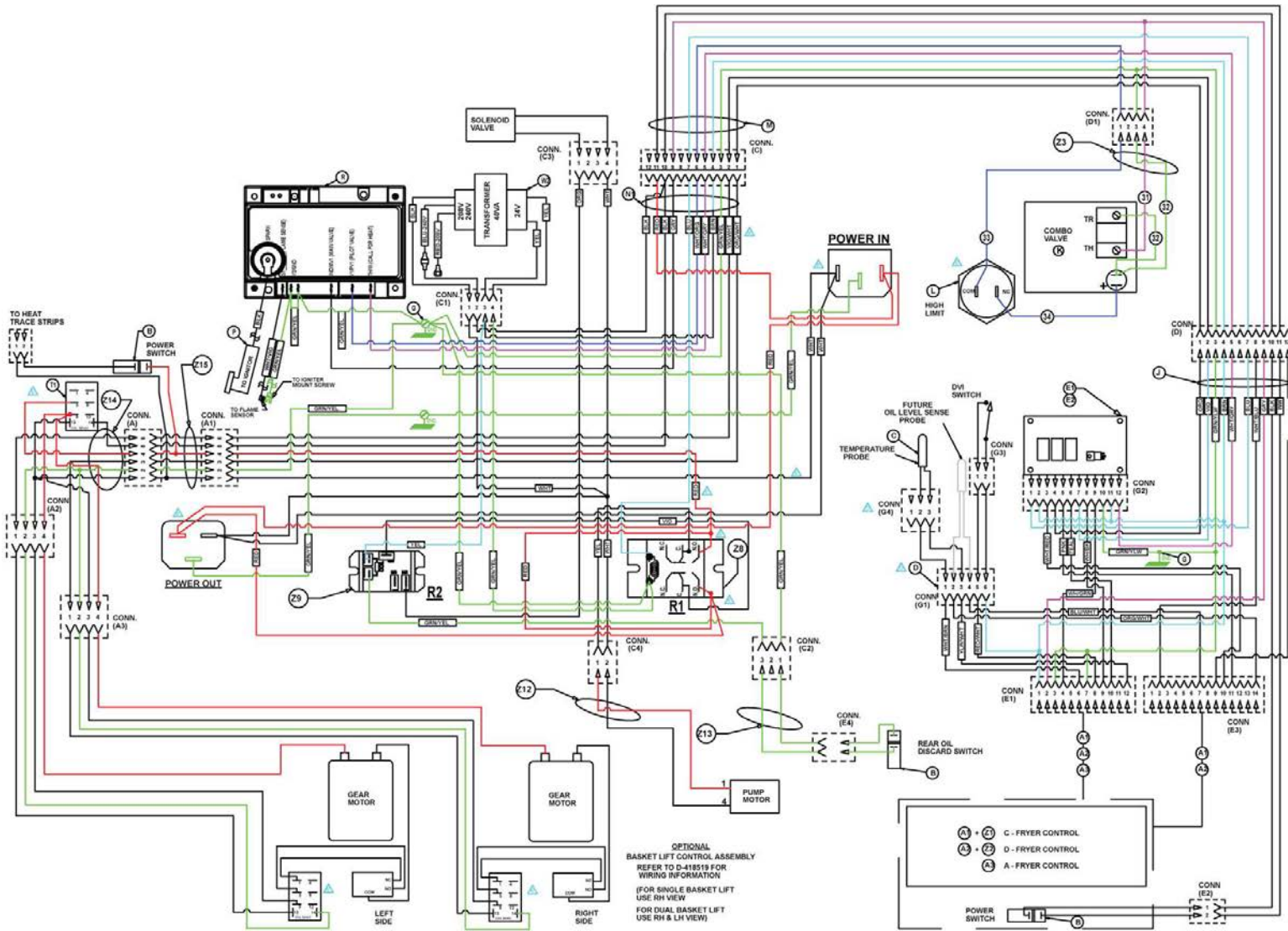

WIRING DIAGRAM, VHG FRYER
OPTION HARNESS, 240VAC
 Refer to Schematic 976718-4
 Derived From 97618-1 Rev G

AI4963

Fig. 99

VHG 120 VAC WIRING DIAGRAM WITH OPTIONS 240 VAC	
ITEM	DESCRIPTION
A1	C-CONTROL
A2	D-CONTROL
A3	A-CONTROL
Z1	HARNESS, CONNECTOR, C-CONTROL
Z2	HARNESS, CONNECTOR, D-CONTROL
B	ROCKER SWITCH ASSEMBLY
C	VHG THERMISTOR PROBE
D	HARNESS, DVI, VHG
E1	INTERFACE BOARD W/ BASKET LIFT
E2	INTERFACE BOARD W/ O BASKET LIFT
G	TERMINIAL, STATIONARY
J	INTERFACE HARNESS
K	COMBO VALVE
L	HI-LIMIT, FENWAL
M	MAIN HARNESS
N1	HARNESS, POWER BOX, OPTION
P	IGNITER CABLE
R	IGNITER MODULE
T1	SWITCH, RELAY 120V
W2	HARNESS, TRANS., 40VA, 208V/240V
Z3	HARNESS, VALVE, GAS
Z8	RELAY 1 HP 120 VOLT
Z9	RELAY SPST 245 VAC COIL
Z12	HARNESS, MOTOR , PUMP, VHG
Z13	HARNESS, FILTER, SWITCH
Z14	HARNESS, BASKET LIFT
Z15	HARNESS, HEAT TRACE

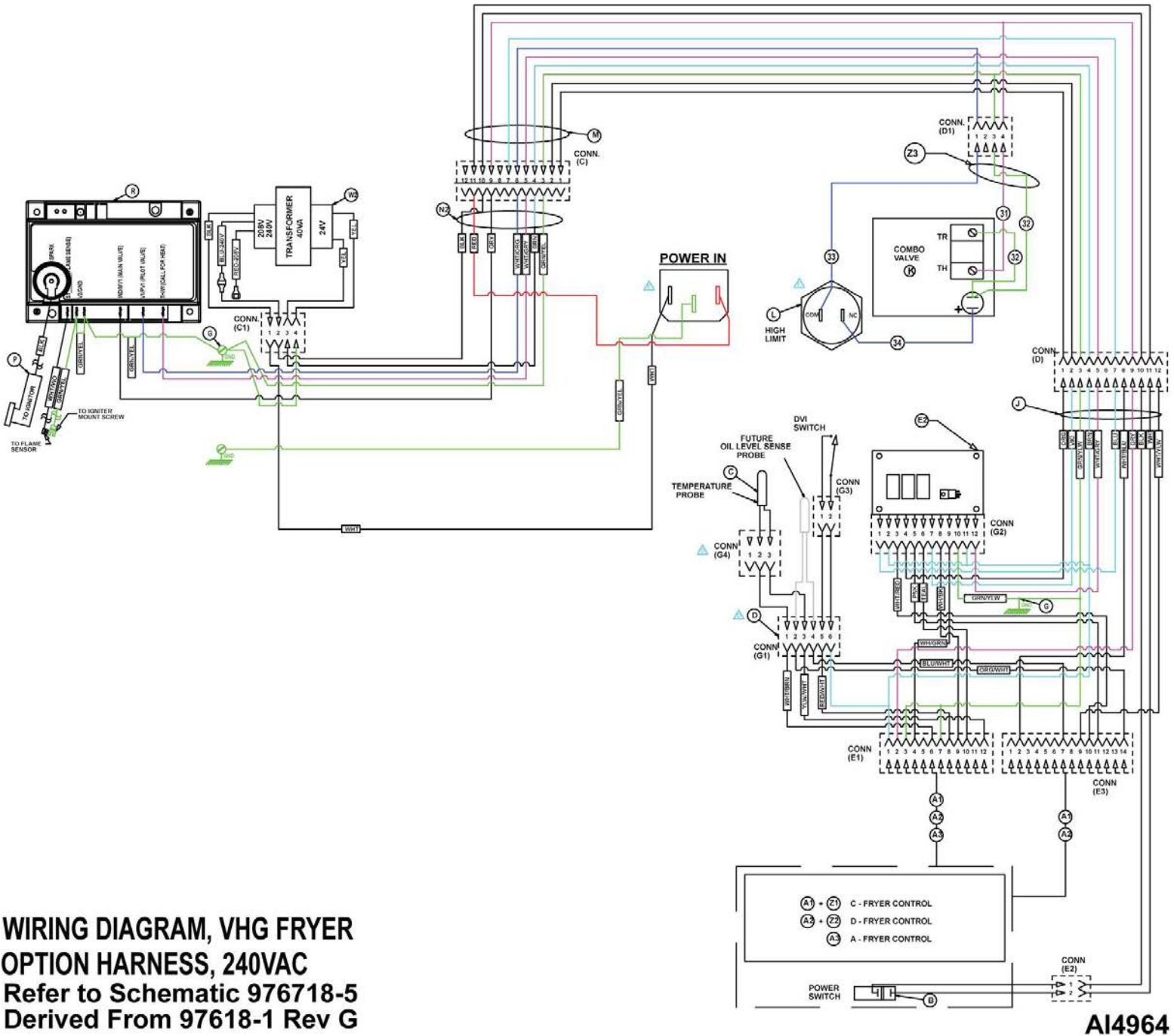

Fig. 100

VHG 120 VAC WIRING DIAGRAM STAND ALONE HARNESS 240 VAC	
ITEM	DESCRIPTION
A1	C-CONTROL
A2	D-CONTROL
A3	A-CONTROL
Z1	HARNESS, CONNECTOR, C-CONTROL
Z2	HARNESS, CONNECTOR, D-CONTROL
B	ROCKER SWITCH ASSEMBLY
C	VHG THERMISTOR PROBE
D	HARNESS, DVI, VHG
E2	INTERFACE BOARD W/ O BASKET LIFT
G	TERMINIAL, STATIONARY
J	INTERFACE HARNESS
K	COMBO VALVE
L	HI-LIMIT, FENWAL
M	MAIN HARNESS
N2	HARNESS, POWER BOX, STANDALONE
P	IGNITER CABLE
R	IGNITER MODULE
W2	HARNESS, TRANS., 40VA, 208V/24V
Z3	HARNESS, VALVE, GAS

TRUBLESHOOTING

TRUBLESHOOTING

ALL MODELS	
SYMPTOMS	POSSIBLE CAUSES
Ignition lockout, continuous loud alarm.	<ol style="list-style-type: none"> 1. Harness connection to gas valve. 2. Gas valve or gas pressure. 3. Store gas supply valve closed. 4. All harness connections. 5. Igniter or igniter wire. 6. Interconnecting wiring malfunction. 7. Flame sense wire disconnected/damaged. 8. High limit. 9. Loss of ground.
Initial alarm then shut off.	<ol style="list-style-type: none"> 1. Grounding status. 2. Check electrode. 3. Loose connection at power outlet. 4. All harness connections. 5. Failed control can also produce this error.
No spark.	<ol style="list-style-type: none"> 1. Harness connections (check for flashing light in A control). 2. Probe lead wires. 3. Control failure. 4. Open fuse on ignition/blower control board. 5. Dry Fire Test being performed; wait 60 seconds. 6. Igniter Wire Damaged/Disconnected. 7. Interface Board Failure. 8. Ignition Module Failure. 9. Shorted Igniter. 10. Loss of ground.
Burner lights but will not maintain flame	<ol style="list-style-type: none"> 1. Igniter/flame sense misaligned. 2. Insufficient gas pressure. 3. Gas supply valve not fully open. 4. Loss of ground.

ALL MODELS	
SYMPTOMS	POSSIBLE CAUSES
<p>Excessive heat</p> <p>NOTE: Assuming the control hasn't failed, all fryers have a built in High Temp alarm that alerts at >40F beyond setpoint or >415F, whichever occurs first.</p> <ul style="list-style-type: none"> • A-control: Display message "HI". • D-control: Display message "HI TEMP" with alarm. • C-control: Display message "HIGH TEMP" with alarm. 	<ol style="list-style-type: none"> 1. Incorrect temperature offset selected. 2. Set temperature exceeding 390°F (198.8°C). 3. Temperature probe malfunction. 4. Cooking control malfunction. 5. Interface board malfunction. 6. Gas pressure incorrect. 7. Harness short circuit. 8. Exhaust flue obstructed. 9. Damaged high limit.
<p>Low heat</p>	<ol style="list-style-type: none"> 1. Incorrect temperature offset selected. 2. Incorrect melt mode selected. 3. Cooking control malfunction. 4. Temperature probe malfunction. 5. High limit tripped. 6. Interface board malfunction. 7. Gas pressure incorrect.
<p>Intermittent problems</p>	<ol style="list-style-type: none"> 1. High ambient temperatures. 2. Wiring connections loose.
<p>No power to cooking control, fryer does not heat</p>	<ol style="list-style-type: none"> 1. Power switch off or malfunction. 2. Main circuit breaker off. 3. Transformer inoperative. 4. Interconnecting wiring malfunction.
<p>High limit thermostat shutting down system</p>	<ol style="list-style-type: none"> 1. Shortening level below minimum fill line. 2. Obstructed flue. NOTE: Causes burners to burn front of the tank and ruin most everything in the front of fryer. 3. Probe malfunction. 4. Control malfunction. 5. Bad high limit.
<p>Excessive time to melt shortening (more than 45 minutes)</p>	<ol style="list-style-type: none"> 1. Incorrect melt mode selected. 2. Melt cycle timing incorrect. 3. Rear gas valve not fully opened. 4. Insufficient gas pressure. 5. Probe malfunction. 6. Control malfunction.

ALL MODELS	
SYMPTOMS	POSSIBLE CAUSES
Dry fire fry tank	<ol style="list-style-type: none"> 1. Magnets are not aligned, control will not call for heat. 2. Incorrect button selection after draining and not refilling tank. 3. Incorrect button selection when starting fryer with empty tank. 4. Incorrect melt mode selection. 5. Control malfunction. 6. Probe malfunction.

INTERFACE CONTROL BOARD PIN-OUTS

INTERFACE BOARD			
PIN NO.	INPUTS	PIN NO.	OUTPUTS
P1	24VAC Filter Output	P6	24VDC Filter Control Input
P2	24VAC Relay Power Input	P7	24VAC Left Basket Lift Output
P3	24VDC Right Basket Lift Control Input	P8	DC (-) Common NOTE: To basket lift relay coil.
P4	24VAC Right Basket Lift Output	P9	24VDC Heat Demand Control Input
P5	24VDC Left Basket Lift Control Input	—	—
P10	System Ground	P12	24VAC Triac Heat Output
P11	24VAC Triac Power Input	---	---

A CONTROL		
Connector Pin	Signal	Direction
1	24VAC 1	INPUT
2	IGNIT STAT	INPUT
3	INPUT COMMON	
4	HEAT	OUTPUT
5	(NC)	*
6	PROBE HIGH	INPUT
7	24VAC 2	INPUT
8	DRAIN VALVE	INPUT
9	OUTPUT COMMON	
10	FILTER	OUTPUT
11	(NC)	*

A CONTROL		
Connector Pin	Signal	Direction
12	PROBE LOW	INPUT

NOTE: * Not used as of 9/1/20.

C AND D CONTROLS		
Connector Pin	Signal	Direction
P1-1	24VAC HOT	INPUT
P1-2	IGNIT STAT	
P1-3	INPUT COMMON	INPUT
P1-4	HEAT	OUTPUT
P1-5	(NC)	*
P1-6	PROBE 1 HIGH	INPUT
P1-7	24VAC NEUTRAL	INPUT
P1-8	DRAIN VALVE	
P1-9	OUTPUT COMMON	INPUT
P1-10	FILTER	OUTPUT
P1-11	(NC)	*
P1-12	PROBE 1 LOW	INPUT
P2-1	(NC)	*
P2-2	GAS RELAY CONTACT 2	*
P2-3	OIL PUMP	*
P2-4	OUTPUT COMMON	*
P2-5	INPUT COMMON	*
P2-6	(NC)	*
P2-7	PROBE 2 LOW	*
P2-8	(NC)	*
P2-9	GAS RELAY CONTACT 1	*
P2-10	RIGHT BASKET LIFT	OUTPUT
P2-11	LEFT BASKET LIFT	OUTPUT
P2-12	OIL VALVE	*
P2-13	(NC)	*
P2-14	PROBE 2 HIGH	*

NOTE: * Not used as of 9/1/20.

VHG PREVENTATIVE MAINTENANCE CHECKLIST

SCHEDULE	CHECK	ACTION
Weekly	Flue	<ul style="list-style-type: none"> When cool, check flue and clear any obstructions.

Annually	Controller	<ul style="list-style-type: none"> • Check temperature calibration. • Check button function. • Check power switch function.
	Oil Leaks	<ul style="list-style-type: none"> • Fry tank weldment. • Return oil lines. • Drain manifold. <ul style="list-style-type: none"> • Couplings. • Drain valves.
	Oil Filter System	<ul style="list-style-type: none"> • Check pump motor function. • Check for oil leaks in return lines with pump under pressure. • Verify two o-rings are present in suction block receptacle. • Verify rinse/discard switch is functioning. • Verify all drain pan rollers and guides are in place and pan moves in and out smoothly.
	Operating Gas Pressure	<ul style="list-style-type: none"> • 3.5" W.C. for natural gas. • 10" W.C. for propane.
	Wiring	<ul style="list-style-type: none"> • Check power cord for damage. • Check internal wiring for damage/loose connections.
	Casters	<ul style="list-style-type: none"> • Check casters for damage.

VHG STANDALONE

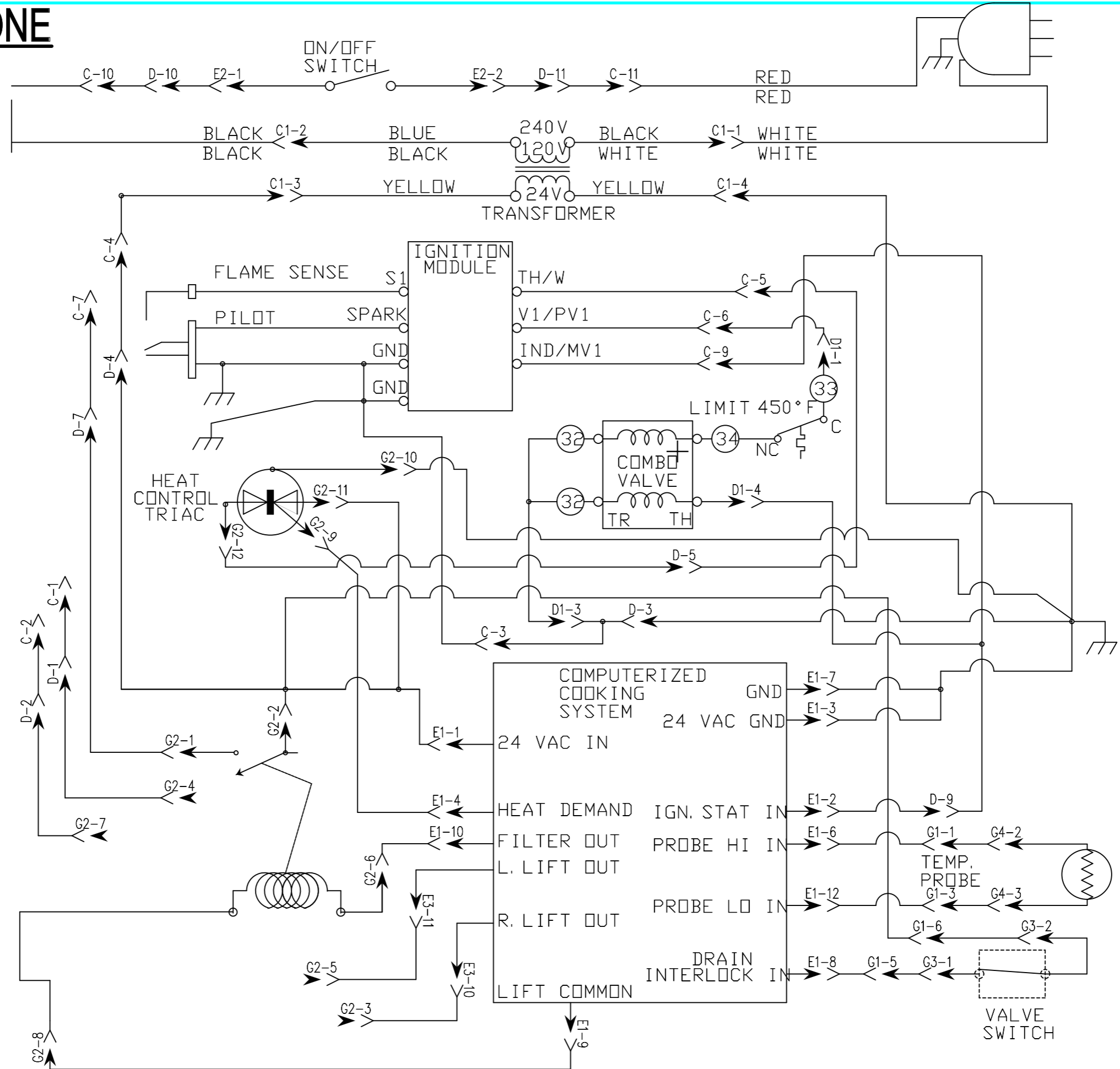

VHG WITH OPTIONS

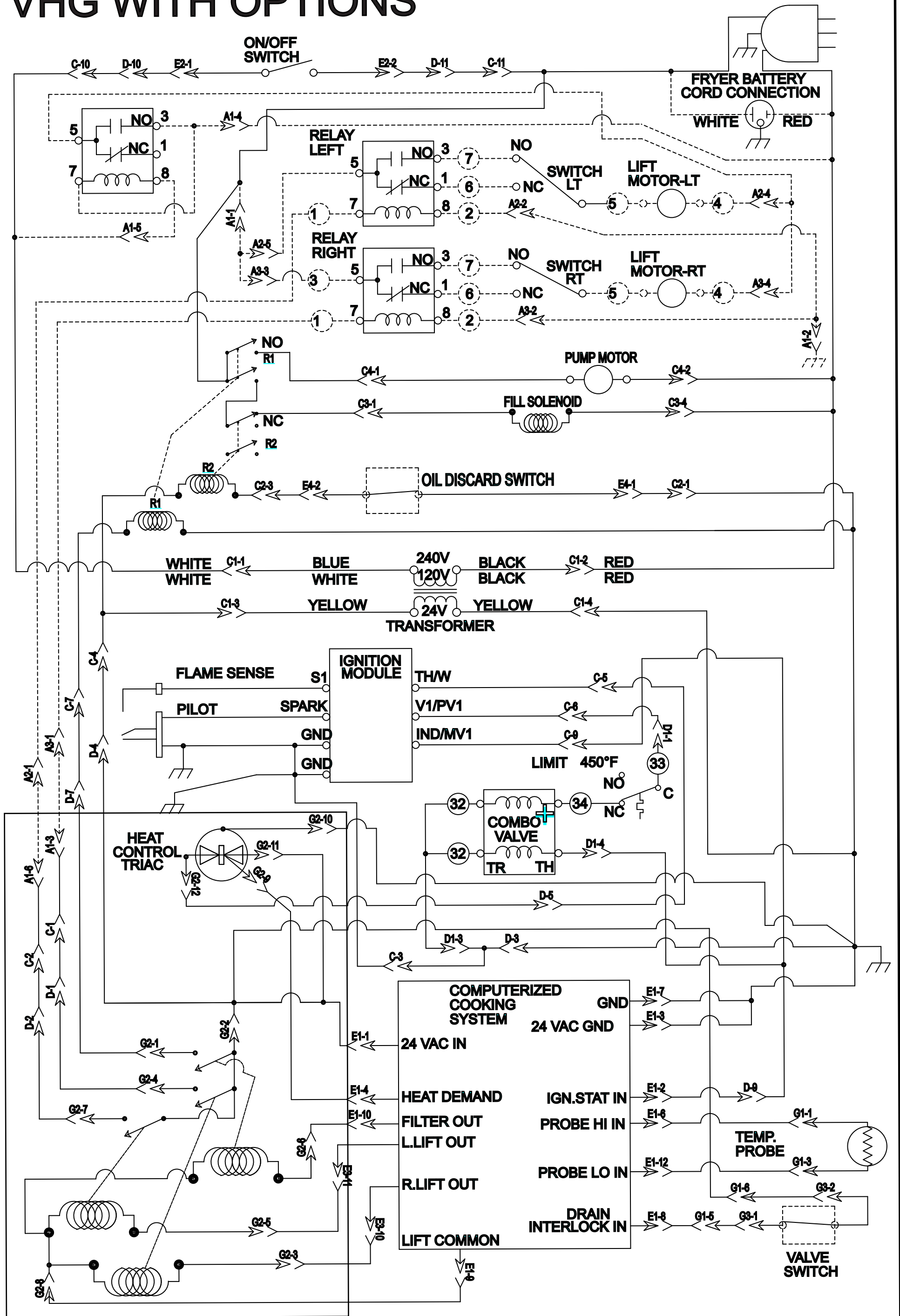

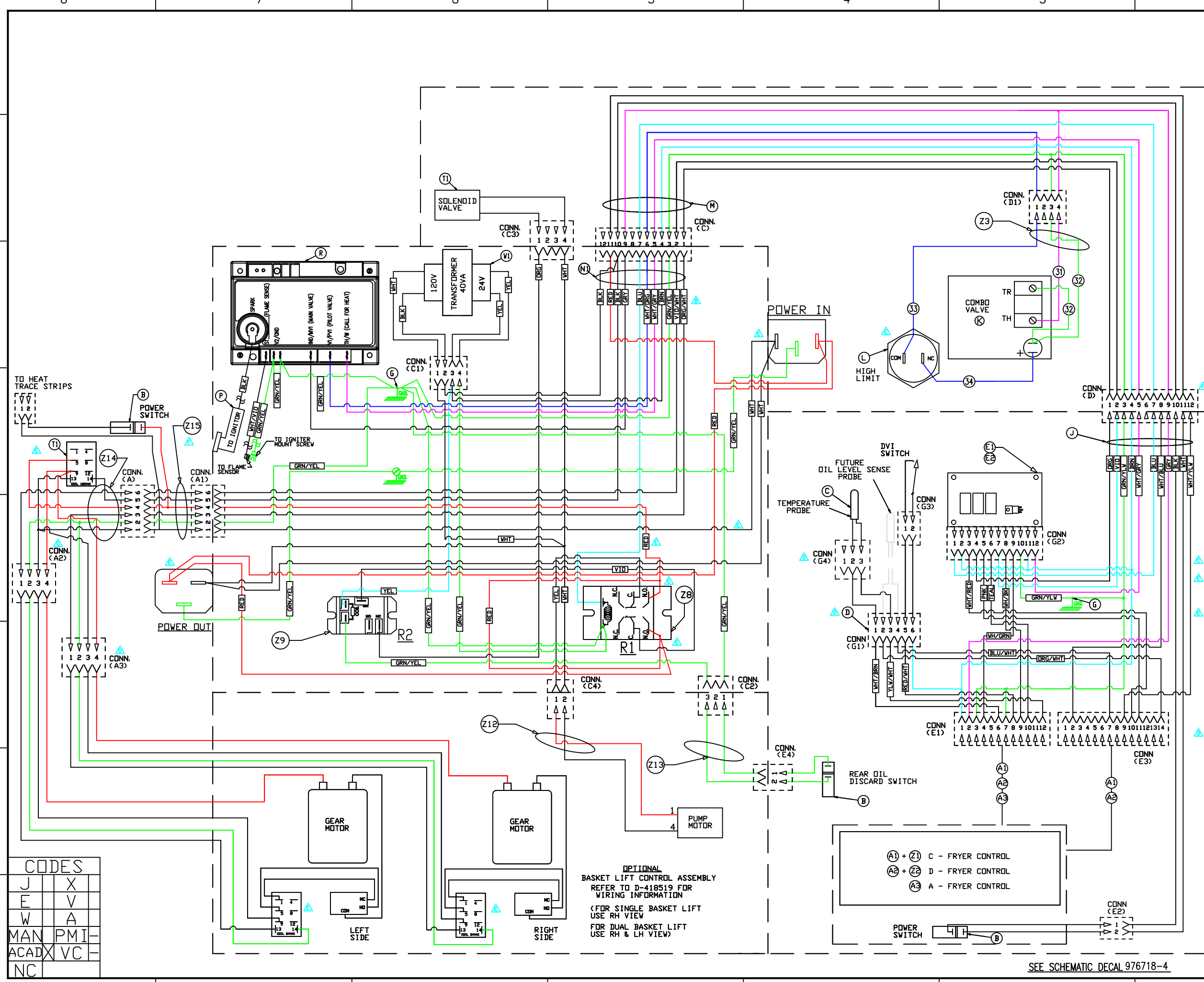

J	X
E	V
W	A
MAN	PMI
ACAD	VC
NC	

OPTIONAL
BASKET LIFT CONTROL ASSEMBLY
REFER TO D-418519 FOR
WIRING INFORMATION
(FOR SINGLE BASKET LIFT
USE RH VIEW
FOR DUAL BASKET LIFT
USE RH & LH VIEW)

Ⓐ + Ⓐ Z1 C - FRYER CONTROL
Ⓐ Z2 D - FRYER CONTROL
Ⓐ A3 A - FRYER CONTROL

SEE SCHEMATIC DECAL 976718-4

ADD	REMOVE	WAS	DRAWING CHANGES		
LTR	DESCRIPTION	ZONE	DATE	PCN #	SIGN
A	FIRST RELEASE OF DRAWING	ALL	7-15-19		MTR
B	ORANGE/WHITE WAS ORANGE VIOLET/WHITE WAS VIOLET T1 WAS T T2 WAS T	ALL	01-06-20		MTR
C	976743-1 WAS 419359	ALL	05-28-20		ALM
D	976721-15 WAS 427750-G1	ALL	02-09-21		MTR
E	976588 WAS 410840-2 976721-16 WAS 976721-11 976721-17 WAS 976721-12 CORRECTED RELAY PIN NAMES 976721-14 WAS 976721-10 REVERSED POLARITY C1-1 AND C1-2 SWAPPED	ALL	04-20-22		MTR
F	ADDED HEAT TRACE HARNESS	ALL	06-17-22		MTR
G	A2 WAS A1 A3 WAS A2	8D 8C	07-29-22		MTR

1	1	1	Z15	HARNESS, HEAT TRACE	-	976721-16
1	1	1	Z14	HARNESS, BASKET LIFT	-	976721-13
1	1	1	Z13	HARNESS, FILTER, SWITCH	-	976721-2
1	1	1	Z12	HARNESS, MOTOR, PUMP, VHG	-	976721-6
1	1	1	Z9	RELAY SPST 24 VAC COIL	-	497125-1
1	1	1	Z8	RELAY 1 HP 120 VOLT	-	428864-1
1	1	1	Z3	HARNESS, VALVE, GAS	-	976721-5
1	1	1	W1	HARNESS, TRANS., 40VA, 120V/24V	-	976721-9
1	1	1	T1	SWITCH, RELAY 120V	-	416535-6
1	1	1	R	IGNITION MODULE	-	857207-4
1	1	1	P	IGNITER CABLE	-	976743-1
1	1	1	N1	HARNESS, POWER BOX, OPTION	-	976721-16
1	1	1	M	MAIN HARNESS	-	976721-1
1	1	1	L	HI-LIMIT, FENVAL	-	976588
1	1	1	K	COMBO VALVE	NAT LP	410841-28 410841-29
1	1	1	J	INTERFACE HARNESS	-	427753-10
2	2	2	G	TERMINAL, STATIONARY	-	419317
1	1	1	E2	INTERFACE BOARD W/O BASKET LIFT	-	427759-3
0	1	1	E1	INTERFACE BOARD W/ BASKET LIFT	-	427759-2
1	1	1	D	HARNESS, DVI, VHG	-	976721-15
1	1	1	C	VHG THERMISTOR PROBE	-	976730-1
2	2	2	B	ROCKER SWITCH ASSEMBLY	-	427755-G1
-	1	-	Z2	HARNESS, CONNECTOR, D-CONTROL	-	976705-4
-	-	1	Z1	HARNESS, CONNECTOR, C-CONTROL	-	976706-8
1	-	-	A3	A-CONTROL	-	976722-3
-	1	-	A2	D-CONTROL	-	976705-3
-	-	1	A1	C-CONTROL	-	976706-7

REQ	REQ	REQ	IT	DESCRIPTION	FIN	PART NO.
VHG A	MIDDEL			WIRING INFORMATION FOR UNITS LISTED WIRING DIAGRAM, VHG FRYER OPTION HARNESS, 120VAC		
VHG D	MIDDEL					
VHG C	MIDDEL					
DRAWN BY MTR 11-27-18				SCALE NTS		
APPROVED BY				D976718-1 REV. G		
SHEET 1 OF 4						

D976718-1 A

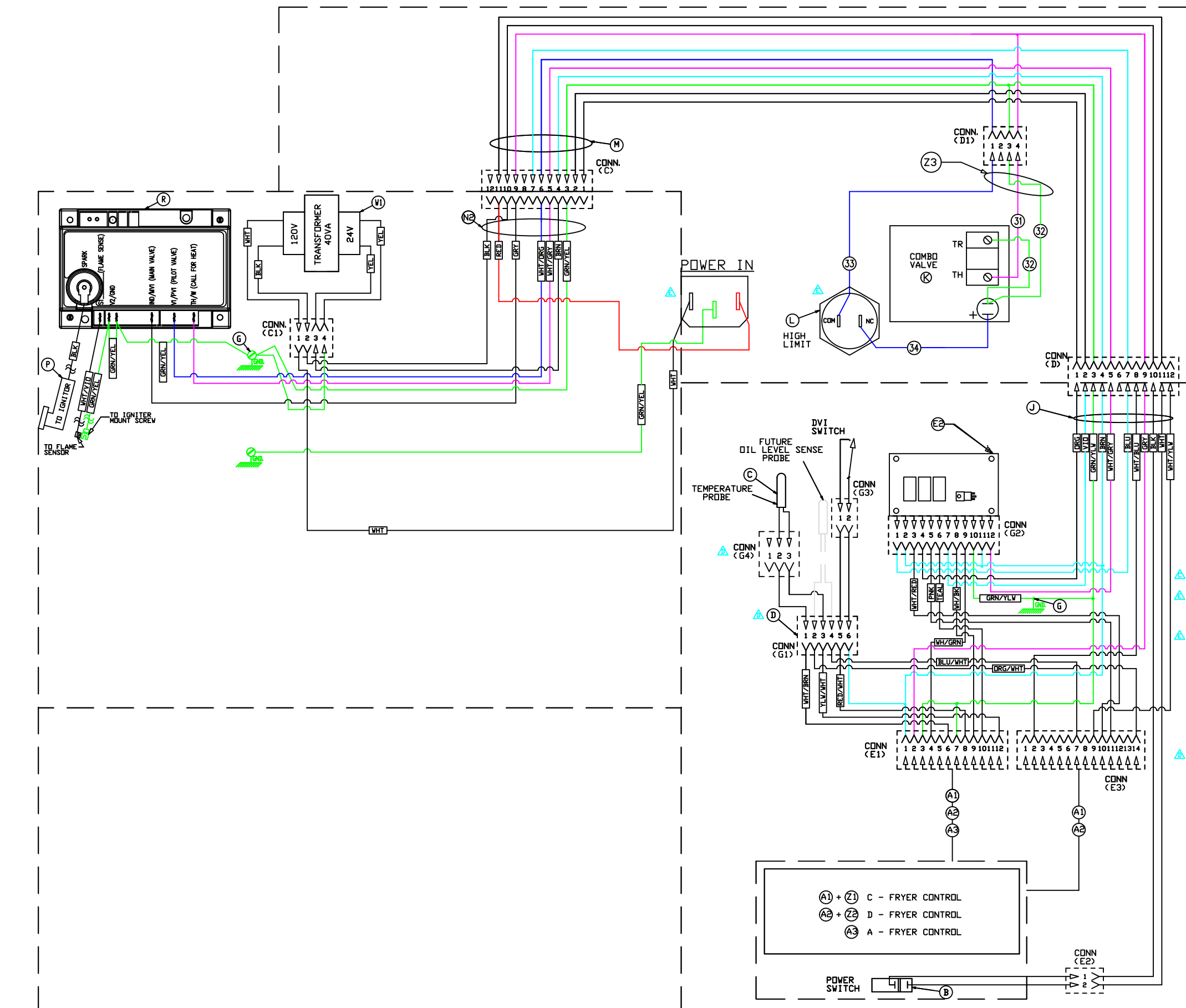

CODES	
J	X
E	V
W	A
MAN	PMI
ACAD	VC
NC	

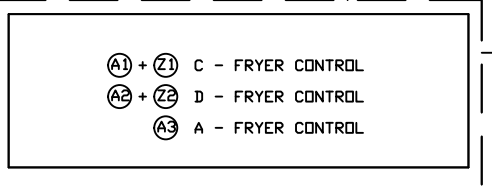

SEE SCHEMATIC DECAL 976718-5

ADD	REMOVE	WAS	DRAWING CHANGES		
LTR	DESCRIPTION	ZONE	DATE	PCN #	SIGN
A	FIRST RELEASE OF DRAWING	ALL	7-15-19		MTR
B	ORANGE/WHITE WAS ORANGE VIOLET/WHITE WAS VIOLET T1 WAS T T2 WAS T	ALL	01-06-20		MTR
C	976743-1 WAS 419359	ALL	05-28-20		ALM
D	976721-15 WAS 427750-G1	ALL	02-09-21		MTR
E	976588 WAS 410840-2 976721-16 WAS 976721-11 976721-17 WAS 976721-12 CORRECTED RELAY PIN NAMES 976721-14 WAS 976721-10 REVERSED POLARITY C1-1 AND C1-2 SWAPPED	ALL	04-20-22		MTR
F	ADDED HEAT TRACE HARNESS	ALL	06-17-22		MTR
G	A2 WAS A1 A3 WAS A2	8D 8C	07-29-22		MTR

1	1	1	Z3	HARNESS, VALVE, GAS	-	976721-5
1	1	1	W1	HARNESS, TRANS., 40VA, 120V/24V	-	976721-9
1	1	1	R	IGNITION MODULE	-	857207-4
1	1	1	P	IGNITER CABLE	-	976743-1
1	1	1	N2	HARNESS, POWER BOX, STANDALONE	-	976721-17
1	1	1	M	MAIN HARNESS	-	976721-1
1	1	1	L	HI-LIMIT, FENWAL	-	976588
1	1	1	K	COMBO VALVE	NAT LP	410841-28 410841-29
1	1	1	J	INTERFACE HARNESS	-	427753-10
2	2	2	G	TERMINAL, STATIONARY	-	419317
1	1	1	E2	INTERFACE BOARD W/O BASKET LIFT	-	427759-3
1	1	1	D	HARNESS, DVI, VHG	-	976721-15
1	1	1	C	VHG THERMISTOR PROBE	-	976730-1
1	1	1	B	ROCKER SWITCH ASSEMBLY	-	427755-G1
-	1	-	Z2	HARNESS, CONNECTOR, D-CONTROL	-	976705-4
-	-	1	Z1	HARNESS, CONNECTOR, C-CONTROL	-	976706-8
1	-	-	A3	A-CONTROL	-	976722-3
-	1	-	A2	D-CONTROL	-	976705-3
-	-	1	A1	C-CONTROL	-	976706-7

REQ	REQ	REQ	IT	DESCRIPTION	FIN	PART NO.
VHG A	MODEL			WIRING INFORMATION FOR UNITS LISTED WIRING DIAGRAM, VHG FRYER STANDALONE HARNESS, 120VAC DRAWN BY MTR 11-27-18 APPROVED BY _____ SHEET 2 OF 4		
VHG D	MODEL					
VHG C	MODEL					
				SCALE NTS		
				D 976718-1		REV. G

D976718-1

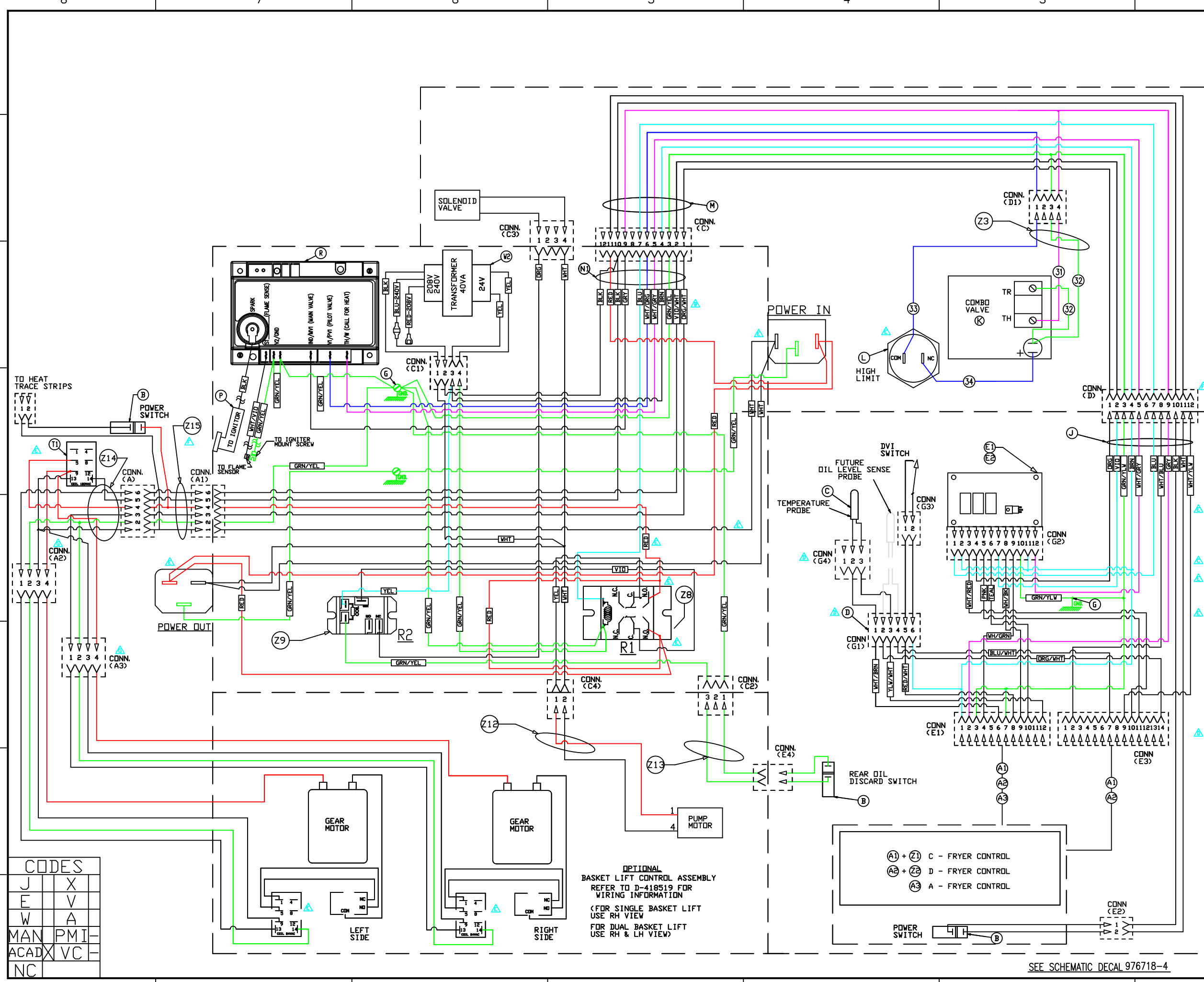

CODES	
J	X
E	V
W	A
MAN	PMI
ACAD	VC
NC	

OPTIONAL
BASKET LIFT CONTROL ASSEMBLY
REFER TO D-418519 FOR
WIRING INFORMATION
(FOR SINGLE BASKET LIFT
USE RH VIEW
FOR DUAL BASKET LIFT
USE RH & LH VIEW)

Ⓐ + Ⓐ Z1 C - FRYER CONTROL
Ⓐ Z2 D - FRYER CONTROL
Ⓐ A3 A - FRYER CONTROL

SEE SCHEMATIC DECAL 976718-4

ADD	REMOVE	WAS	DRAWING CHANGES		
LTR	DESCRIPTION	ZONE	DATE	PCN #	SIGN
A	FIRST RELEASE OF DRAWING	ALL	7-15-19		MTR
B	ORANGE/WHITE WAS ORANGE VIOLET/WHITE WAS VIOLET T1 WAS T T2 WAS T	ALL	01-06-20		MTR
C	976743-1 WAS 419359	ALL	05-28-20		ALM
D	976721-15 WAS 427750-G1	ALL	02-09-21		MTR
E	976588 WAS 410840-2 976721-16 WAS 976721-11 976721-17 WAS 976721-12 CORRECTED RELAY PIN NAMES 976721-14 WAS 976721-10 REVERSED POLARITY C1-1 AND C1-2 SWAPPED	ALL	04-20-22		MTR
F	ADDED HEAT TRACE HARNESS	ALL	06-17-22		MTR
G	A2 WAS A1 A3 WAS A2	8D 8C	07-29-22		MTR

1	1	1	Z15	HARNESS, HEAT TRACE	-	976721-16
1	1	1	Z14	HARNESS, BASKET LIFT	-	976721-13
1	1	1	Z13	HARNESS, FILTER, SWITCH	-	976721-2
1	1	1	Z12	HARNESS, MOTOR, PUMP, VHG	-	976721-6
1	1	1	Z9	RELAY SPST 24 VAC COIL	-	497125-1
1	1	1	Z8	RELAY 1 HP 120 VOLT	-	428864-1
1	1	1	Z3	HARNESS, VALVE, GAS	-	976721-5
1	1	1	V2	HARNESS, XFRMR, 40VA, 208V/24V	-	976721-14
1	1	1	T2	SWITCH, RELAY 240V	-	416535-7
1	1	1	R	IGNITION MODULE	-	857207-4
1	1	1	P	IGNITER CABLE	-	976743-1
1	1	1	NI	HARNESS, POWER BOX, OPTION	-	976721-16
1	1	1	M	MAIN HARNESS	-	976721-1
1	1	1	L	HI-LIMIT, FENVAL	-	976588
1	1	1	K	COMBO VALVE	NAT LP	410841-28 410841-29
1	1	1	J	INTERFACE HARNESS	-	427753-10
2	2	2	G	TERMINAL, STATIONARY	-	419317
1	1	1	E2	INTERFACE BOARD W/O BASKET LIFT	-	427759-3
0	1	1	E1	INTERFACE BOARD W/ BASKET LIFT	-	427759-2
1	1	1	D	HARNESS, DVI, VHG	-	976721-15
1	1	1	C	VHG THERMISTOR PROBE	-	976730-1
2	2	2	B	ROCKER SWITCH ASSEMBLY	-	427755-G1
-	1	-	Z2	HARNESS, CONNECTOR, D-CONTROL	-	976705-4
-	-	1	Z1	HARNESS, CONNECTOR, C-CONTROL	-	976706-8
1	-	-	A3	A-CONTROL	-	976722-3
-	1	-	A2	D-CONTROL	-	976705-3
-	-	1	A1	C-CONTROL	-	976706-7

REQ	REQ	REQ	IT	DESCRIPTION	FIN	PART NO.
WIRING INFORMATION FOR UNITS LISTED						
WIRING DIAGRAM, VHG FRYER OPTION HARNESS, 240VAC						
VHG A MODEL	VHG D MODEL	VHG C MODEL	DRAWN BY MTR 11-27-18			
			APPROVED BY		SCALE NTS	
			SHEET 3 OF 4		D976718-1 REV. G	

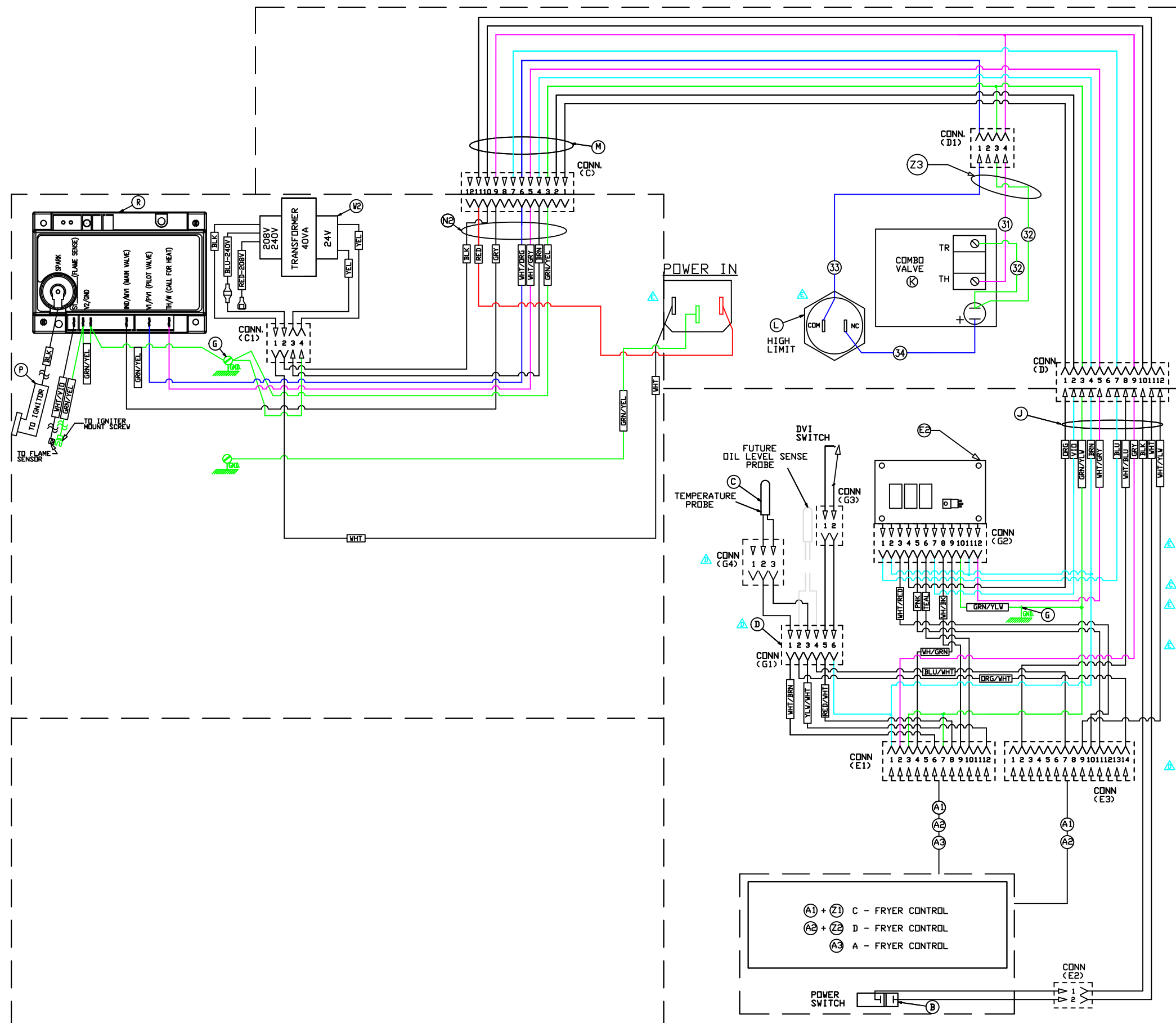

CODES	
J	X
E	V
W	A
MAN	PMI
ACAD	VC
NC	

(A1) + (Z1) C - FRYER CONTROL
 (A2) + (Z2) D - FRYER CONTROL
 (A3) A - FRYER CONTROL

SEE SCHEMATIC DECAL 976718-5

ADD	REMOVE	WAS	DRAWING CHANGES		
LTR	DESCRIPTION	ZONE	DATE	PCN #	SIGN
A	FIRST RELEASE OF DRAWING	ALL	7-15-19		MTR
B	ORANGE/WHITE WAS ORANGE VIOLET/WHITE WAS VIOLET T1 WAS T T2 WAS T	ALL	01-06-20		MTR
C	976743-1 WAS 419359	ALL	05-28-20		ALM
D	976721-15 WAS 427750-G1	ALL	02-09-21		MTR
E	976588 WAS 410840-2 976721-16 WAS 976721-11 976721-17 WAS 976721-12 CORRECTED RELAY PIN NAMES 976721-14 WAS 976721-10 REVERSED POLARITY C1-1 AND C1-2 SWAPPED	ALL	04-20-22		MTR
F	ADDED HEAT TRACE HARNESS	ALL	06-17-22		MTR
G	A2 WAS A1 A3 WAS A2	8D 8C	07-29-22		MTR

1	1	1	Z3	HARNESS, VALVE, GAS	-	976721-5
1	1	1	W2	HARNESS, XFRMR, 40VA, 208V/24V	-	976721-14
1	1	1	R	IGNITION MODULE	-	857207-4
1	1	1	P	IGNITER CABLE	-	976743-1
1	1	1	N2	HARNESS, POWER BOX, STANDALONE	-	976721-17
1	1	1	M	MAIN HARNESS	-	976721-1
1	1	1	L	HI-LIMIT, FENWAL	-	976588
1	1	1	K	COMBO VALVE	NAT LP	410841-28 410841-29
1	1	1	J	INTERFACE HARNESS	-	427753-10
2	2	2	G	TERMINAL, STATIONARY	-	419317
1	1	1	E2	INTERFACE BOARD W/O BASKET LIFT	-	427759-3
1	1	1	D	HARNESS, DVI, VHG	-	976721-15
1	1	1	C	VHG THERMISTOR PROBE	-	976730-1
1	1	1	B	ROCKER SWITCH ASSEMBLY	-	427755-G1
-	1	-	Z2	HARNESS, CONNECTOR, D-CONTROL	-	976705-4
-	-	1	Z1	HARNESS, CONNECTOR, C-CONTROL	-	976706-8
1	-	-	A3	A-CONTROL	-	976722-3
-	1	-	A2	D-CONTROL	-	976705-3
-	-	1	A1	C-CONTROL	-	976706-7

REQ	REQ	REQ	IT	DESCRIPTION	FIN	PART NO.
VHG A	MODEL			WIRING INFORMATION FOR UNITS LISTED WIRING DIAGRAM, VHG FRYER STANDALONE HARNESS, 240VAC		
VHG D	MODEL					
VHG C	MODEL					
DRAWN BY MTR 11-27-18				SCALE NTS		
APPROVED BY _____				D 976718-1 REV. G		
SHEET 4 OF 4						

D976718-1