

VULCAN

CATALOG OF REPLACEMENT PARTS

VK & TR SERIES FRYERS

*See Page 2 for Complete List
of ML's Covered in This Catalog*



For additional information on Vulcan-Hart Company or to locate an authorized parts and service provider in your area, visit our website at www.vulcanequipment.com

VK Series Without Filter

ML-136885	1VK45A
ML-136886	1VK45D
ML-136887	1VK45C
ML-136888	1VK65A
ML-136889	1VK65D
ML-136890	1VK65C
ML-136891	1VK85A
ML-136892	1VK85D
ML-136893	1VK85C

TR Series Without Filter

ML-136946	1TR45A
ML-136951	1TR45D
ML-136956	1TR45C
ML-136961	1TR65A
ML-136965	1TR65D
ML-136969	1TR65C
ML-136973	1TR85A
ML-136977	1TR85D
ML-136981	1TR85C

VK Series With Filter

ML-136894	1VK45AF
ML-136895	1VK45DF
ML-136896	1VK45CF
ML-136897	1VK65AF
ML-136898	1VK65DF
ML-136899	1VK65CF
ML-136900	1VK85AF
ML-136901	1VK85DF
ML-136902	1VK85CF
ML-136903	2VK45AF
ML-136904	2VK45DF
ML-136905	2VK45CF
ML-136906	2VK65AF
ML-136907	2VK65DF
ML-136908	2VK65CF
ML-136909	2VK85AF
ML-136910	2VK85DF
ML-136911	2VK85CF
ML-136912	3VK45AF
ML-136913	3VK45DF
ML-136914	3VK45CF
ML-136915	3VK65AF
ML-136916	3VK65DF
ML-136917	3VK65CF
ML-136918	3VK85AF
ML-136919	3VK85DF
ML-136920	3VK85CF
ML-136921	4VK45AF
ML-136922	4VK45DF
ML-136923	4VK45CF
ML-136935	4VK65AF
ML-136941	4VK65DF
ML-136937	4VK65CF
ML-136938	4VK85AF
ML-136939	4VK85DF
ML-136940	4VK85CF

TR Series With Filter

ML-136947	1TR45AF
ML-136952	1TR45DF
ML-136957	1TR45CF
ML-136962	1TR65AF
ML-136966	1TR65DF
ML-136970	1TR65CF
ML-136974	1TR85AF
ML-136978	1TR85DF
ML-136982	1TR85CF
ML-136948	2TR45AF
ML-136953	2TR45DF
ML-136958	2TR45CF
ML-136963	2TR65AF
ML-136967	2TR65DF
ML-136971	2TR65CF
ML-136975	2TR85AF
ML-136979	2TR85DF
ML-136983	2TR85CF
ML-136949	3TR45AF
ML-136954	3TR45DF
ML-136959	3TR45CF
ML-136964	3TR65AF
ML-136968	3TR65DF
ML-136972	3TR65CF
ML-136976	3TR85AF
ML-136980	3TR85DF
ML-136984	3TR85CF
ML-136950	4TR45AF
ML-136955	4TR45DF
ML-136960	4TR45CF
ML-136985	4TR65AF
ML-136986	4TR65DF
ML-136987	4TR65CF
ML-136988	4TR85AF
ML-136989	4TR85DF
ML-136990	4TR85CF

Table of Contents

5 BEHIND DOOR CONTROL BOX ASSEMBLY
7 CONTROL PANELS
9 POWER SUPPLY BOX (BEFORE 12/1/12)
11 POWER SUPPLY BOX (STARTING 12/1/12)
13 TANK AND GAS COMPONENTS
15 GAS INLET MANIFOLD
17 BODY UNIT (A/C/D SERIES) (NON- FILTER)
19 BODY UNIT (A/C/D SERIES) (FILTER)
21 DRAIN ASSEMBLY (SINGLE UNIT)
23 DRAIN ASSEMBLY (MULTIPLE UNITS)
25 OIL RETURN (SINGLE UNIT)
27 OIL RETURN (MULTIPLE UNITS)
29 FILTER ASSEMBLY (SINGLE UNIT)
31 FILTER ASSEMBLY (MULTIPLE UNITS)
33 BASKETLIFT COMPONENTS

- 13 00-956368-000G1 Control Box Assy. (LH) (W/Filter Switch)
- 14 00-956368-000G2 Control Box Assy. (RH) (W/Filter Switch)
- 15 00-956368-000G3 Control Box Assy. (LH) (W/O Filter Switch)

PARTS NOT ILLUSTRATED

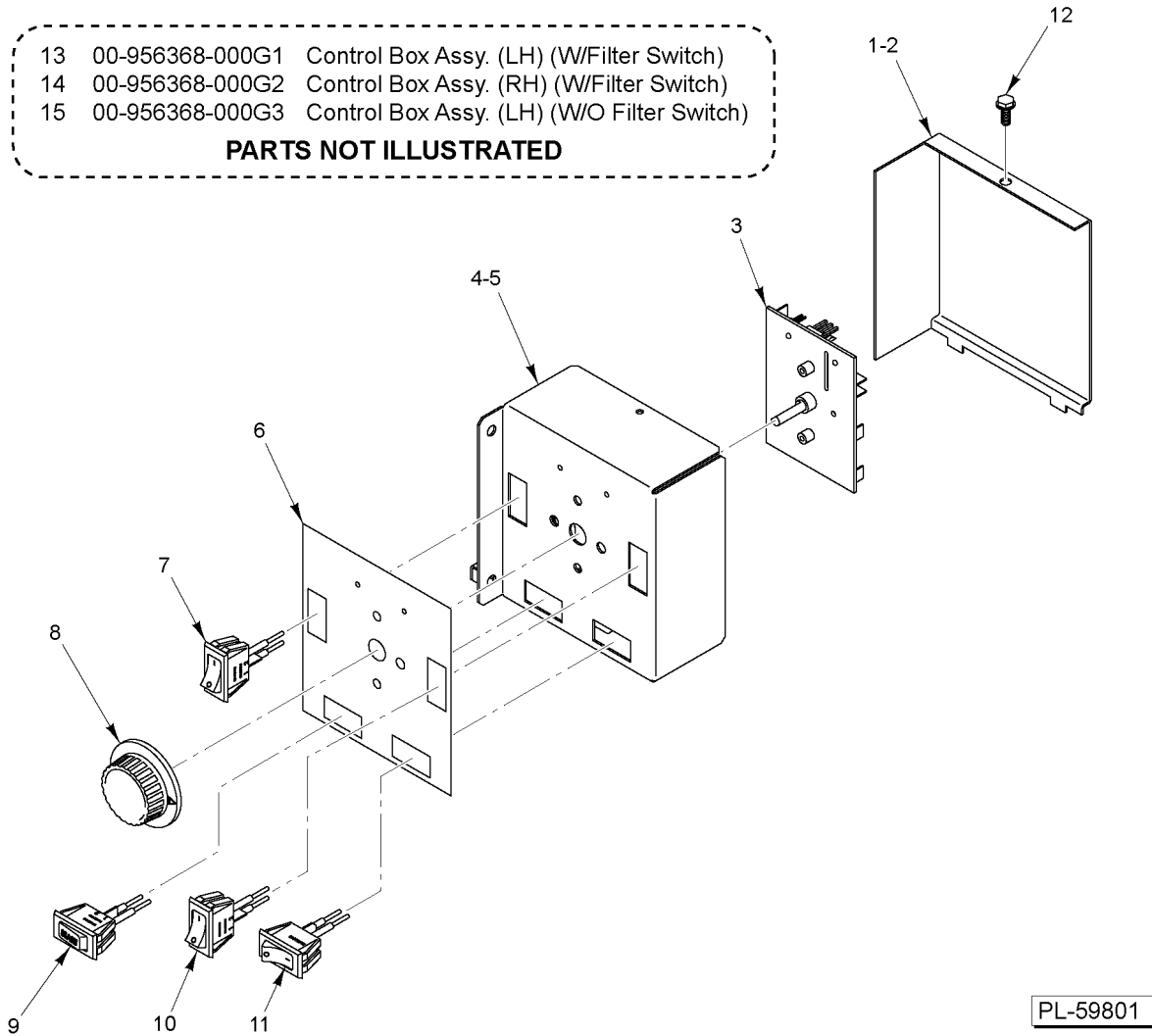

PL-59801

BEHIND DOOR CONTROL BOX ASSEMBLY

BEHIND DOOR CONTROL BOX ASSEMBLY

ILLUS.	PART NO.	NAME OF PART	AMT.
PL-59801			
1	00-957822-00004	Cover - Control Box (LH).....	1
2	00-957822-00005	Cover - Control Box (RH).....	1
3	00-956926-000G3	Control Assy. - Temperature (W/ LED's).....	1
4	00-499716-00001	Plate - Control Mounting (LH).....	1
5	00-499716-00002	Plate - Control Mounting (RH).....	1
6	00-956827-00002	Overlay.....	1
7	00-427755-000G1	Rocker Switch Assy. (Power).....	1
8	00-411242-00001	Knob.....	1
9	00-427755-000G2	Rocker Switch Assy. (Start).....	1
10	00-427755-000G1	Rocker Switch Assy. (Power).....	1
11	00-426251-00002	Plug (Non-Filter).....	1
12	SD-032-07	Self-Tapping Screw 10-24 x 1/2 Hex Washer Hd., Type TT.....	1
13	00-956368-000G1	Control Box Assy. (LH) (W/Filter Switch) (Incls. Items 1, 3, 4, 6 thru 10, & 12).....	1
14	00-956368-000G2	Control Box Assy. (RH) (W/Filter Switch) (Incls. Items 2, 3, 5 thru 10, & 12).....	1
15	00-956368-000G3	Control Box Assy. (LH) (W/O Filter Switch) (Incls. Items 1, 3, 4, & 6 thru 12).....	1

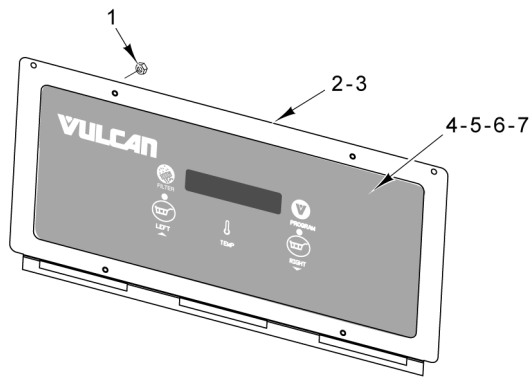

D SERIES

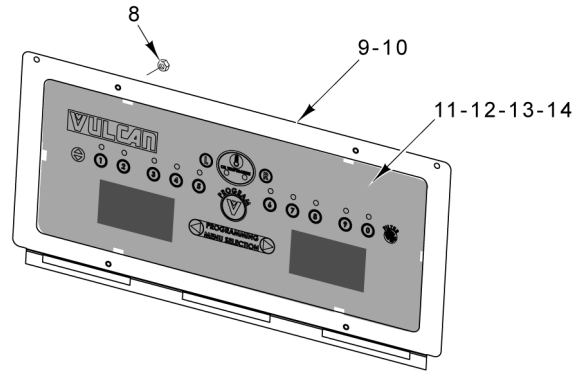

C SERIES

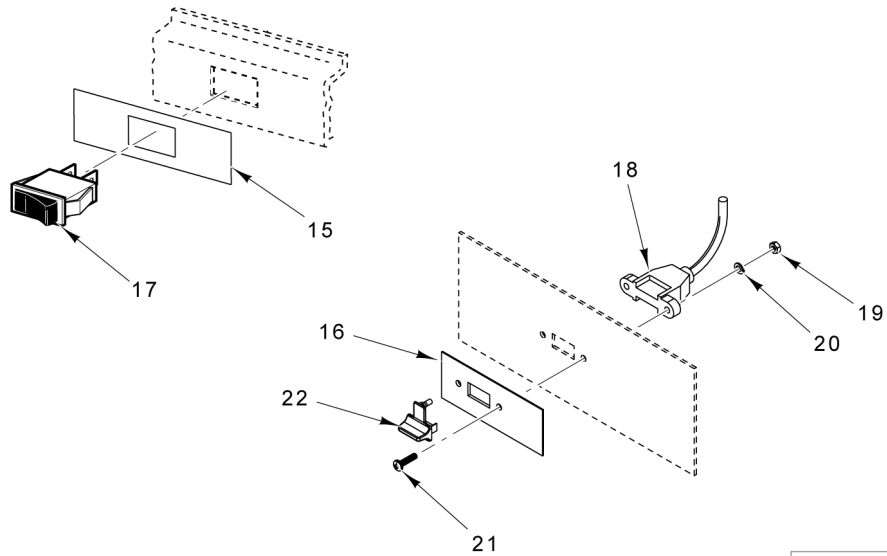

PL-59802

CONTROL PANELS

CONTROL PANELS

ILLUS.	PART NO.	NAME OF PART	AMT.
1	NS-046-89	Nut Assy. 6-32 Hex.....	4
2	00-426815-000G1	Plate Assy. - Mounting (45 Series).....	1
3	00-426815-000G2	Plate Assy. - Mounting (65/85 Series).....	1
4	00-497745-00001	Overlay - Vulcan (Filter).....	1
5	00-497745-00003	Overlay - Vulcan (Boil).....	1
6	00-913086-00004	Control Assy. - Solid State (Filter Button) (Incls. Item 4).....	1
7	00-913086-00003	Control Assy. - Solid State (Boil Button) (Incls. Item 5).....	1
8	NS-046-89	Nut Assy. 6-32 Hex.....	4
9	00-426815-000G1	Plate Assy. - Mounting (45 Series).....	1
10	00-426815-000G2	Plate Assy. - Mounting (65/85 Series).....	1
11	00-913086-00002	Computer Cooking Assy. (Filter Button) (Incls. Item 13).....	1
12	00-913086-00001	Computer Cooking Assy. (Boil Button) (Incls. Item 14).....	1
13	00-958620-00001	Overlay - Vulcan (Filter Button).....	1
14	00-958620-00002	Overlay - Vulcan (Boil Button).....	1
15	00-428906-00001	Overlay - Power.....	1
16	00-428906-00004	Overlay (USB Port).....	1
17	00-427755-000G1	Rocker Switch Assy.....	1
18	00-959000-000G1	Cable Assy. (USB) (1 Ft.) (Incls. Items 19 thru 22).....	1
19		Nut 4-40 Hex.....	2
20		Lockwasher #4.....	2
21		Screw 4-40 x 1/2.....	2
22	00-959000-00002	Cap (USB).....	1

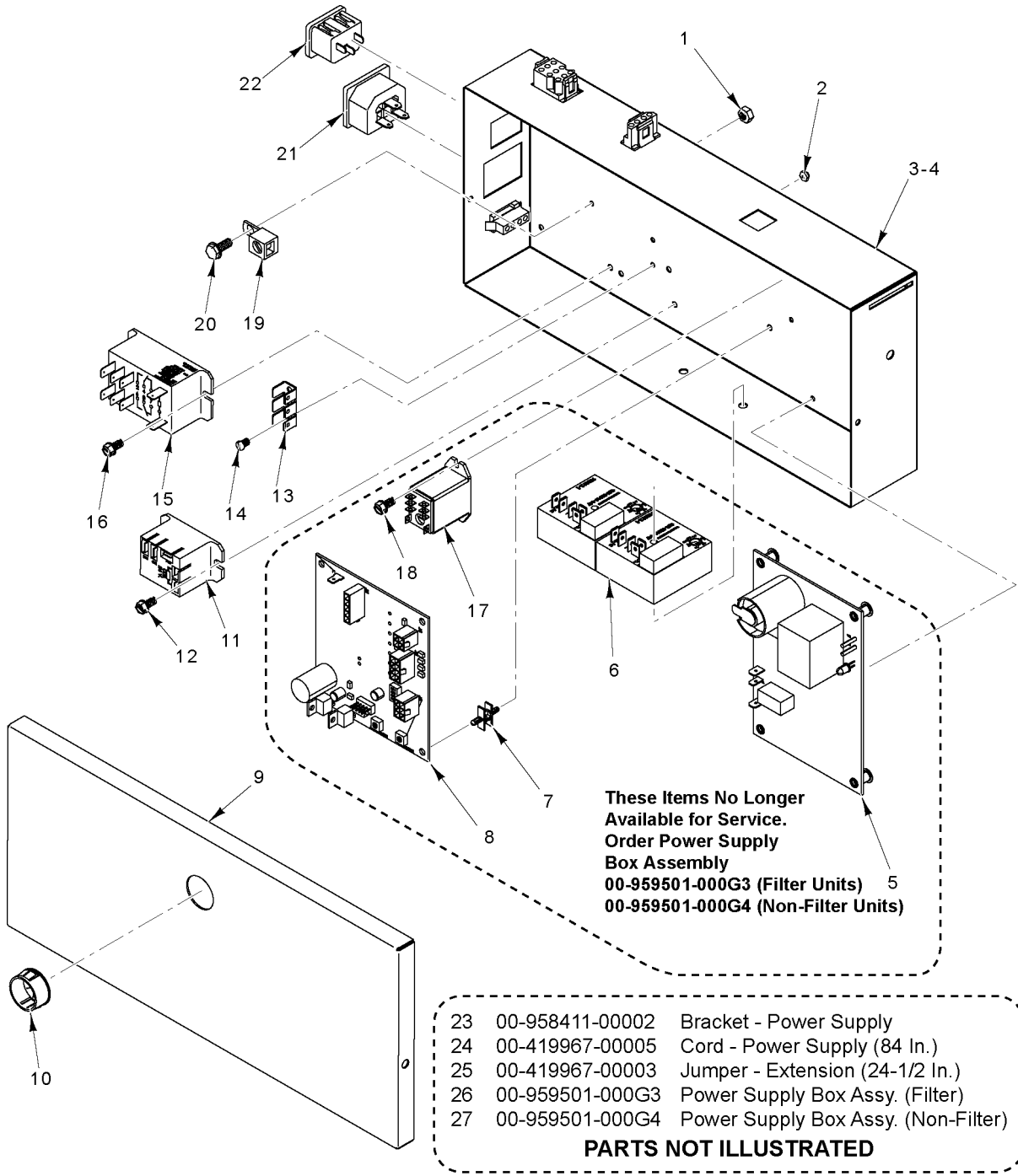

PL-59803

**POWER SUPPLY BOX
(BEFORE 12/1/12)**

**POWER SUPPLY BOX
(BEFORE 12/1/12)**

ILLUS.	PART NO.	NAME OF PART	AMT.
PL-59803			
1	NS-044-09	Nut Assy. 10-24 Hex KEPS.....	1
2	NS-047-32	Lock Nut 4-40.....	2
3	00-958404-000G1	Box - Power Supply (Filter).....	1
4	00-958404-000G2	Box - Power Supply (Non-Filter).....	1
*5		Module - Ignition.....	1
*6		Timer - Delay.....	2
*7		Standoff.....	4
*8		Board - Blower Control.....	1
9	00-958405-00001	Lid - Power Supply.....	1
10	FE-024-24	Bushing - Electrical Snap.....	1
11	00-497125-00001	Relay (SPDT, 24 VAC) (Filter - Solenoid Valve).....	1
12	SD-036-03	Self-Tapping Screw 8-18 x 3/8 Hex Washer Hd., Type AB.....	2
13	00-419317	Terminal - Stationary.....	1
14	SC-060-23	Mach. Screw 4-40 x 1/4 Slotted Rd. Hd.....	2
15	00-428864-00001	Relay (Filter - Pump Motor).....	1
16	SD-036-03	Self-Tapping Screw 8-18 x 3/8 Hex Washer Hd., Type AB.....	2
*17		Switch - Relay.....	1
18	SD-036-03	Self-Tapping Screw 8-18 x 3/8 Hex Washer Hd., Type AB.....	2
19	00-417856-00001	Lug - Grounding (With Set Screw).....	1
20	SD-032-07	Self-Tapping Screw 10-24 x 1/2 Hex Washer Hd., Type TT.....	1
21	00-419973-000G2	Receptacle - Female Power (Filter).....	1
22	00-419973-000G1	Receptacle - Male Power.....	1
23	00-958411-00002	Bracket - Power Supply.....	1
24	00-419967-00005	Cord - Power Supply (84 In.).....	1
25	00-419967-00003	Jumper - Extension (24-1/2 In.).....	1
26	00-959501-000G3	Power Supply Box Assy. (Filter).....	1
27	00-959501-000G4	Power Supply Box Assy. (Non-Filter).....	1

* (Item No Longer Available for Service on these Models. Order Item 26 or 27.)

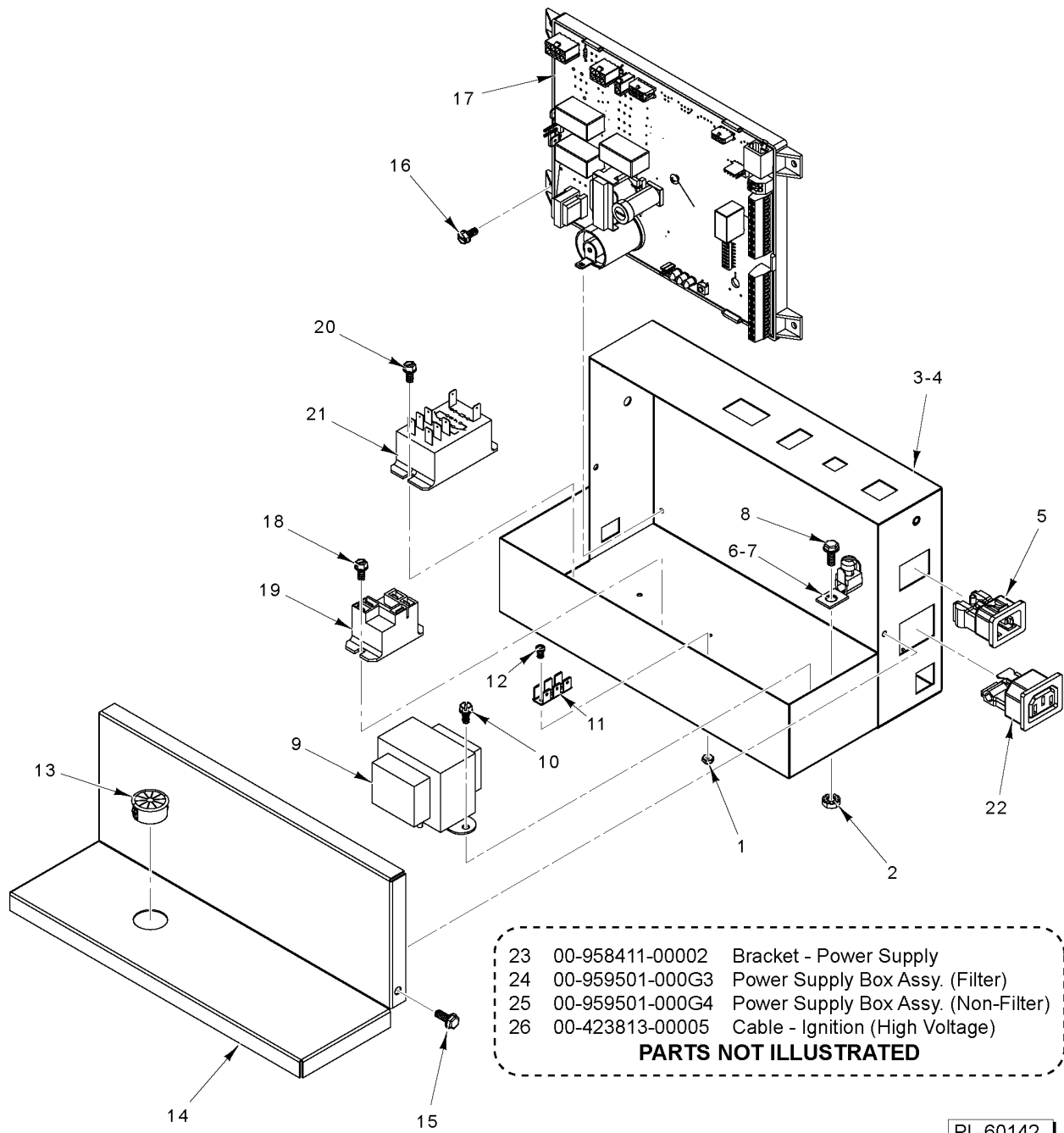

- | | | |
|----|-----------------|-------------------------------------|
| 23 | 00-958411-00002 | Bracket - Power Supply |
| 24 | 00-959501-000G3 | Power Supply Box Assy. (Filter) |
| 25 | 00-959501-000G4 | Power Supply Box Assy. (Non-Filter) |
| 26 | 00-423813-00005 | Cable - Ignition (High Voltage) |
- PARTS NOT ILLUSTRATED**

PL-60142

**POWER SUPPLY BOX
(STARTING 12/1/12)**

**POWER SUPPLY BOX
(STARTING 12/1/12)**

ILLUS. PL-60142	PART NO.	NAME OF PART	AMT.
1	NS-047-32	Lock Nut 4-40.....	2
2	NS-044-09	Nut Assy. 10-24 Hex KEPS.....	1
3	00-959498-000G3	Box - Power Supply (Filter).....	1
4	00-959498-000G4	Box - Power Supply (Non-Filter).....	1
5	00-419973-000G1	Receptacle - Male Power.....	1
6	00-417856-00001	Lug - Grounding (With Set Screw).....	1
7		Set Screw (Included With Item 6).....	1
8	SD-032-07	Self-Tapping Screw 10-24 x 1/2 Hex Washer Hd., Type TT.....	1
9	00-411500-00012	Transformer (120 VAC, 24 V., 40 VA).....	1
10	SD-036-03	Self-Tapping Screw 8-18 x 3/8 Hex Washer Hd., Type AB.....	2
11	00-419317	Terminal - Stationary.....	1
12	SC-060-23	Mach. Screw 4-40 x 1/4 Slotted Rd. Hd.....	2
13	FE-024-24	Bushing - Electrical Snap.....	1
14	00-959499-00002	Lid - Power Supply.....	1
15	SD-032-07	Self-Tapping Screw 10-24 x 1/2 Hex Washer Hd., Type TT.....	2
16	SD-036-03	Self-Tapping Screw 8-18 x 3/8 Hex Washer Hd., Type AB.....	4
17	00-959500-00001	Gas Ignitor - Board.....	1
18	SD-036-03	Self-Tapping Screw 8-18 x 3/8 Hex Washer Hd., Type AB.....	2
19	00-497125-00001	Relay (SPDT, 24 VAC) (Filter - Solenoid Valve).....	1
20	SD-036-03	Self-Tapping Screw 8-18 x 3/8 Hex Washer Hd., Type AB.....	2
21	00-428864-00001	Relay (Filter - Pump Motor).....	1
22	00-419973-000G2	Receptacle - Female Power (Filter).....	1
23	00-958411-00002	Bracket - Power Supply.....	1
24	00-959501-000G3	Power Supply Box Assy. (Filter) (Incls. Items 1, 2, 3, & 5 thru 22).....	1
25	00-959501-000G4	Power Supply Box Assy. (Non-Filter) (Incls. Items 1, 2, & 4 thru 17).....	1
26	00-423813-00005	Cable - Ignition (High Voltage).....	1

TANK AND GAS COMPONENTS

ILLUS.	PART NO.	NAME OF PART	AMT.
	PL-59804		
1	00-427882-000G3	Tube - Flex (Gas Inlet).....	1
2	00-958067-00001	Bracket - Heat Shield.....	1
3	NS-044-09	Nut Assy. 10-24 Hex KEPS.....	8
4	00-958691-00002	Burner - Ceramic.....	1
5	00-959046-00001	Filter - Blower (VK Series Only).....	1
6	00-976613-00002	Gasket - Transport Tube (Lower).....	1
7	00-958453-000G1	Harness - Gas Solenoid (Before 8/10/17, Used with Item 10).....	1
8	00-976589	Harness - Gas Solenoid (Starting 8/10/17, Used with Item 11).....	1
9	00-959080-00001	Bracket - High Limit.....	1
10	00-958475	Control - High Limit (Capillary Wire Type) (Before 8/10/17).....	1
11	00-976588	Control - High Limit (No Capillary Wire) (Starting 8/10/17).....	1
12	SD-032-07	Self-Tapping Screw 10-24 x 1/2 Hex Washer Hd., Type TT.....	6
13	SD-036-86	Self-Tapping Screw 10-24 x 3/4 Hex Hd. Type TT.....	4
14	00-959879-000G2	Tube - Transport.....	1
15	SC-127-31	Mach. Screw 1/4-20 x 3/4 Hex Hd. (SST).....	2
16	00-976641	Kit - Ignitor with Gaskets (Incls. Items 6, 14, 18, & 22) (Before 6/22/17).....	1
17	00-976568	Kit - Ignitor (Incls. Electrode & Gasket) (Starting 6/22/17).....	1
18	00-959100-00001	Gasket - Electrode.....	1
19	00-958505-00002	Plate - Orifice (45 Series).....	1
20	00-958505-00003	Plate - Orifice (65 Series).....	1
21	00-958505-00004	Plate - Orifice (85 Series).....	1
22	00-959100-00002	Gasket - Transport Tube (Upper).....	1
*23	00-958689-000G2	Tank Assy. (TR45 Series).....	1
**24	00-976558-000G2	Tank Assy. (TR45 Series).....	1
*25	00-958704-000G2	Tank Assy. (TR65 Series).....	1
**26	00-976562-000G2	Tank Assy. (TR65 Series).....	1
*27	00-958700-000G2	Tank Assy. (TR85 Series).....	1
**28	00-976564-000G2	Tank Assy. (TR85 Series).....	1
*29	00-958689-000G1	Tank Assy. (VK45 Series).....	1
**30	00-976558-000G1	Tank Assy. (VK45 Series).....	1
*31	00-958704-000G1	Tank Assy. (VK65 Series).....	1
**32	00-976562-000G1	Tank Assy. (VK65 Series).....	1
*33	00-958700-000G1	Tank Assy. (VK85 Series).....	1
**34	00-976564-000G1	Tank Assy. (VK85 Series).....	1
35	00-408279-00022	Regulator - Pressure (3/4 In.) (NAT) (On Units Before 4/17/16).....	1
36	00-408279-00021	Regulator - Pressure 3/4 In. (LP) (3/4 In.) (LP) (On Units Before 4/17/16).....	1
37	00-408279-00012	Regulator - Pressure (1-1/4 In.) (NAT) (On Units Before 4/17/16).....	1
38	00-408279-00013	Regulator - Pressure (1-1/4 In.) (LP) (On Units Before 4/17/16).....	1
39	00-944782-VK45N	Gas Valve & Blower Assy. (NAT) (VK45).....	1
40	00-944782-VK45P	Gas Valve & Blower Assy. (LP) (VK45).....	1
41	00-944782-VK65N	Gas Valve & Blower Assy. (NAT) (VK65).....	1
42	00-944782-VK65P	Gas Valve & Blower Assy. (LP) (VK65).....	1
43	00-944782-VK85N	Gas Valve & Blower Assy. (NAT) (VK85).....	1
44	00-944782-VK85P	Gas Valve & Blower Assy. (LP) (VK85).....	1
45	00-944782-TR45N	Gas Valve & Blower Assy. (NAT) (TR45).....	1
46	00-944782-TR45P	Gas Valve & Blower Assy. (LP) (TR45).....	1
47	00-944782-TR65N	Gas Valve & Blower Assy. (NAT) (TR65).....	1
48	00-944782-TR65P	Gas Valve & Blower Assy. (LP) (TR65).....	1
49	00-944782-TR85N	Gas Valve & Blower Assy. (NAT) (TR85).....	1
50	00-944782-TR85P	Gas Valve & Blower Assy. (LP) (TR85).....	1
51	00-958455-000G1	Harness - Main.....	1
52	00-427750-000G1	Harness (Interface to DVI).....	1
53	00-958452-000G1	Harness - Blower.....	1

* (Revision A - Manufactured before 8/1/17 with drain valve handle mounted at 12 o'clock position. The filter system drain manifolds are 2-1/4 In. diameter and painted black.)

** (Revision B - Manufactured after 8/1/17 with drain valve handle mounted at 10 o'clock position. The filter system drain manifolds are 3 In. diameter and painted red.)

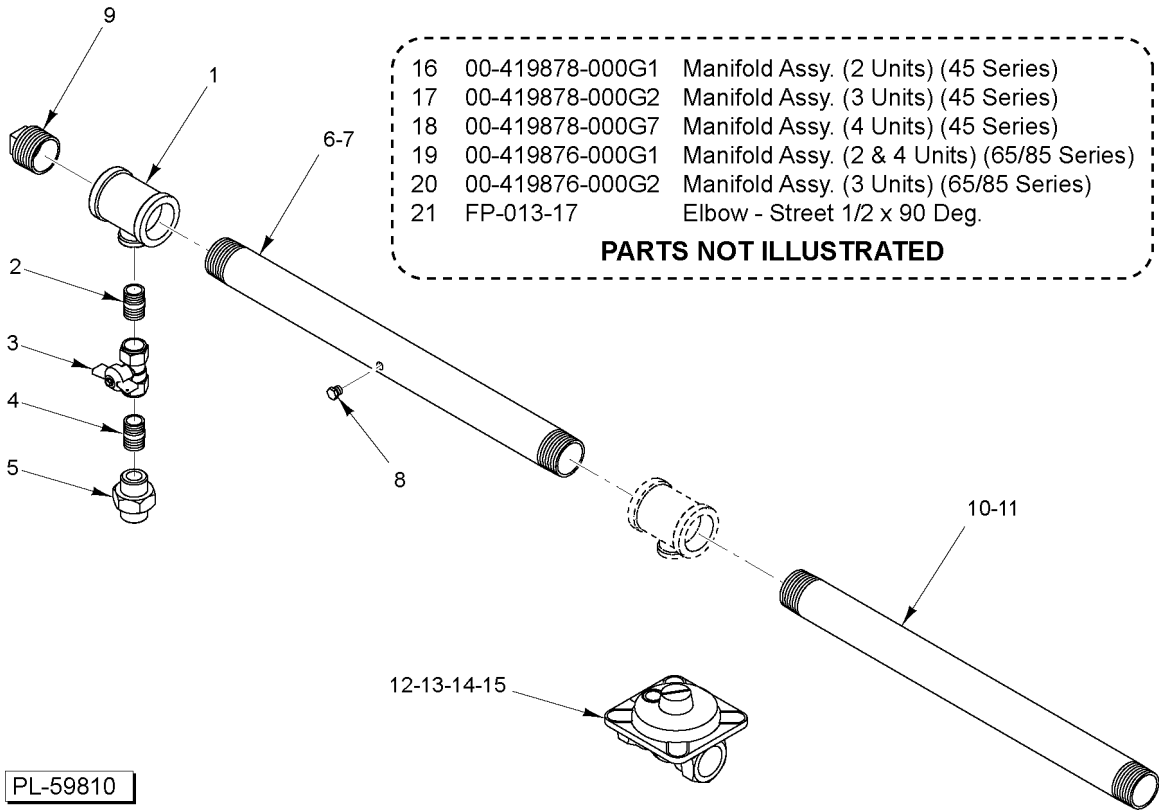

GAS INLET MANIFOLD

GAS INLET MANIFOLD

ILLUS.	PART NO.	NAME OF PART	AMT.
PL-59810			
1	FP-090-80	Tee 1-1/4 x 1-1/4 x 1/2.....	AR
2	FP-035-91	Pipe 1/2 x 1-1/8 TBE.....	AR
3	00-428472-00001	Valve - Ball.....	AR
4	FP-035-91	Pipe 1/2 x 1-1/8 TBE.....	AR
5	FP-022-11	Union - Pipe.....	AR
6	00-957744-00001	Pipe - Rear Gas (With Tap) (45 Series).....	AR
7	00-957744-00002	Pipe - Rear Gas (With Tap) (65/85 Series).....	AR
8	FP-085-53	Pipe Plug 1/8.....	AR
9	FP-028-26	Pipe Plug 1-1/4 Sq. Hd.....	AR
10	00-957744-00004	Pipe - Rear Gas (Without Tap) (45 Series).....	AR
11	00-957744-00003	Pipe - Rear Gas (Without Tap) (65/85 Series).....	AR
12	00-408279-00022	Regulator - Pressure (3/4 In.) (NAT) (On Units Before 4/17/16).....	AR
13	00-408279-00021	Regulator - Pressure 3/4 In. (LP) (3/4 In.) (LP) (On Units Before 4/17/16).....	AR
14	00-408279-00012	Regulator - Pressure (1-1/4 In.) (NAT) (On Units Before 4/17/16).....	AR
15	00-408279-00013	Regulator - Pressure (1-1/4 In.) (LP) (On Units Before 4/17/16).....	AR
16	00-419878-000G1	Manifold Assy. - Gas Inlet (2 Units) (45 Series) (Incls. Items 1 thru 6, 8, & 9).....	AR
17	00-419878-000G2	Manifold Assy. - Gas Inlet (3 Units) (45 Series) (Incls. Items 1 thru 6, 8, 9, & 10).....	AR
18	00-419878-000G7	Manifold Assy. - Gas Inlet (4 Units) (45 Series) (Incls. Items 1 thru 6, 8, 9, & 10).....	AR
19	00-419876-000G1	Manifold Assy. - Gas Inlet (2 & 4 Units) (65/85 Series) (Incls. Items 1 thru 5, 7, 8, 9, & 11).....	AR
20	00-419876-000G2	Manifold Assy. - Gas Inlet (3 Units) (65/85 Series) (Incls. Items 1 thru 5, 7, 8, 9, & 11).....	AR
21	FP-013-17	Elbow - Street 1/2 x 90 Deg.....	AR

44 00-421756-00001 Brush - Fryer Cleaning
PART NOT ILLUSTRATED

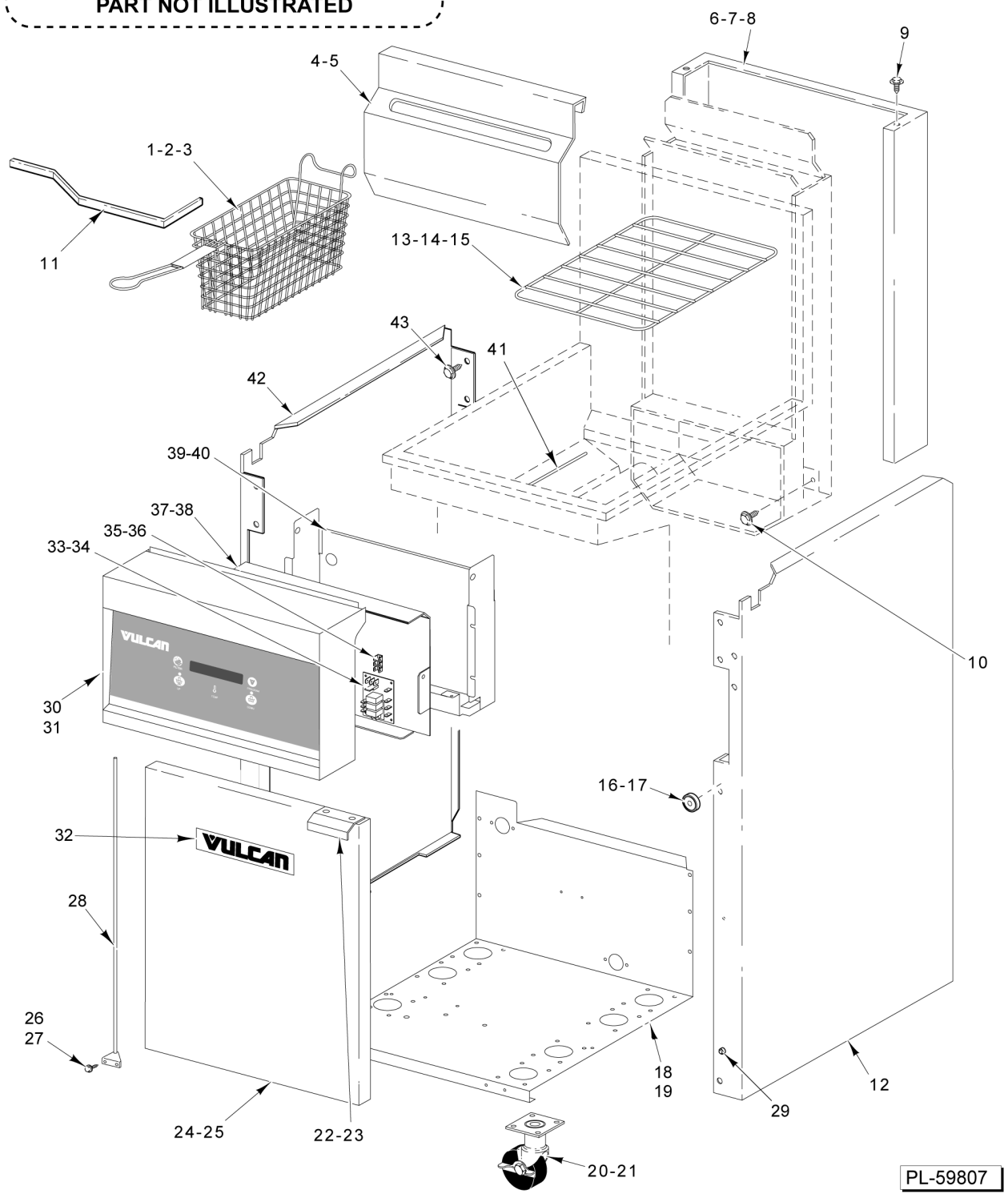

PL-59807

**BODY UNIT
(A/C/D SERIES)
(NON-FILTER)**

**BODY UNIT
(A/C/D SERIES)
(NON- FILTER)**

ILLUS. PL-59807	PART NO.	NAME OF PART	AMT.
1	00-499223-00001	Basket - Twin (45 Series).....	AR
2	00-499223-00002	Basket - Twin (65 Series).....	AR
3	00-499223-00004	Basket - Twin (85 Series).....	AR
4	00-417056-00002	Hanger - Basket (45 Series).....	1
5	00-418321-00002	Hanger - Basket (65/85 Series).....	1
6	00-958711-00001	Flue - Wrap (SST) (45 Series).....	1
7	00-958711-000G2	Flue - Wrap (SST) (65 Series).....	1
8	00-418336-00002	Flue - Wrap (SST) (85 Series).....	1
9	SD-032-07	Self-Tapping Screw 10-24 x 1/2 Hex Washer Hd., Type TT.....	2
10	SD-037-70	Self-Tapping Screw 1/4-20 x 1/2 Hex Washer Hd., Type TT.....	4
11	00-409300-00005	Rod - Clean-Out.....	1
12	00-420596-00004	Body - Side (SST) (RH).....	1
13	00-427883-00001	Screen - Basket Support (45 Series).....	1
14	00-427883-00003	Screen - Basket Support (65 Series).....	1
15	00-427883-00004	Screen - Basket Support (85 Series).....	1
16	RS-033-04	Rivet - Pop.....	1
17	00-497296-000G2	Magnet Assy.....	1
18	00-497428-00002	Body - Bottom (45 Series).....	1
19	00-497428-00004	Body - Bottom (65/85 Series).....	1
20	00-421893-00001	Caster - Plate Mount (W/ Brake).....	AR
21	00-421893-00002	Caster - Plate Mount (No Brake).....	AR
22	00-419653	Handle.....	1
23	RS-033-04	Rivet - Pop.....	2
24	00-499487-000G1	Door Assy. (LH) (45 Series).....	1
25	00-499487-000G5	Door Assy. (LH) (65/85 Series).....	1
26	SD-032-07	Self-Tapping Screw 10-24 x 1/2 Hex Washer Hd., Type TT.....	2
27	NS-044-09	Nut Assy. 10-24 Hex KEPS.....	2
28	00-428023-000G2	Hinge Assy.....	1
29	00-420769-00001	Bumper - Rubber.....	1
30	00-426806-000G1	Frame - Front Assy. (45 Series).....	1
31	00-426806-000G4	Frame - Front Assy. (65/85 Series).....	1
32	00-957916-00005	Nameplate - Vulcan.....	1
33	00-427759-00001	Control - Interface.....	1
34	SD-024-40	Self-Tapping Screw 6-32 x 5/8 Phil. Pan Hd., Type TT.....	4
35	00-419317	Terminal - Stationary.....	1
36	SC-060-23	Mach. Screw 4-40 x 1/4 Slotted Rd. Hd.....	2
37	00-428541-00001	Plate - Control Mounting.....	1
38	00-428541-00002	Extension - Control (65/85 Series).....	1
39	00-428542-00002	Deflector Assy. (45 Series).....	1
40	00-428689-00002	Deflector Assy. (65/85 Series).....	1
41	00-958474	Probe - Temperature.....	1
42	00-420596-00003	Body - Side (SST) (LH).....	1
43	SD-036-03	Self-Tapping Screw 8-18 x 3/8 Hex Washer Hd., Type AB.....	AR
44	00-421756-00001	Brush - Fryer Cleaning.....	1

- 51 00-410863-00002 Strip - Grease (45/65 Series)
- 52 00-410863-00006 Strip - Grease (85 Series)
- 53 00-421756-00001 Brush - Fryer Cleaning

PARTS NOT ILLUSTRATED

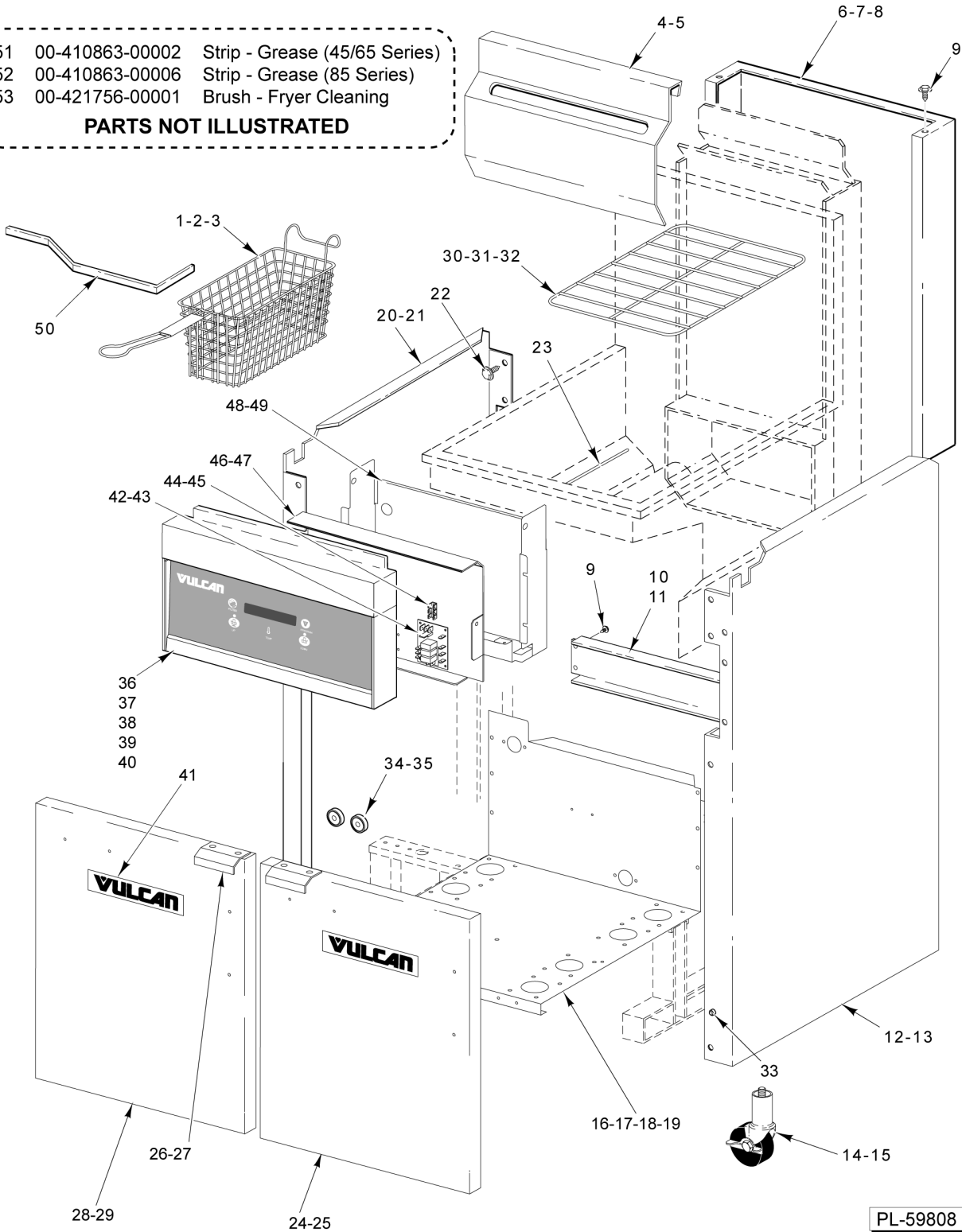

PL-59808

**BODY UNIT
(A/C/D SERIES) (FILTER)**

**BODY UNIT
(A/C/D SERIES) (FILTER)**

ILLUS.	PART NO.	NAME OF PART	AMT.
PL-59808			
1	00-499223-00001	Basket - Twin (45 Series).....	AR
2	00-499223-00002	Basket - Twin (65 Series).....	AR
3	00-499223-00004	Basket - Twin (85 Series).....	AR
4	00-417056-00002	Hanger - Basket (45 Series).....	2
5	00-418321-00002	Hanger - Basket (65/85 Series).....	2
6	00-958711-00001	Flue - Wrap (SST) (45 Series).....	1
7	00-958711-000G2	Flue - Wrap (SST) (65 Series).....	1
8	00-418336-00002	Flue - Wrap (SST) (85 Series).....	1
9	SD-032-07	Self-Tapping Screw 10-24 x 1/2 Hex Washer Hd., Type TT.....	AR
10	00-428699-00002	Brace - Rear (45 Series).....	1
11	00-428749-00002	NLA - Obsolete--Brace - Rear (65/85 Series).....	1
*12	00-419777-00004	Body - Side (SST) (RH).....	1
**13	00-420596-00004	Body - Side (SST) (RH).....	1
14	00-959832-00001	Caster - Screw-In Mount (W/ Brake).....	AR
15	00-959832-00003	Caster - Screw-In Mount (No Brake).....	AR
16	00-497428-00001	Body - Bottom (22-1/2 Deep) (45 Series) (Section W/O Filter).....	1
17	00-497428-00002	Body - Bottom (27-1/2 Deep) (45 Series) (Section W/O Filter).....	1
18	00-497428-00003	Body - Bottom (22-1/2 Deep) (65/85 Series) (Section W/O Filter).....	1
19	00-497428-00004	Body - Bottom (27-1/2 Deep) (65/85 Series) (Section W/O Filter).....	1
*20	00-419777-00003	Body - Side (SST) (LH).....	1
**21	00-420596-00003	Body - Side (SST) (LH).....	1
22	SD-036-03	Self-Tapping Screw 8-18 x 3/8 Hex Washer Hd., Type AB.....	AR
23	00-958474	Probe - Temperature.....	1
24	00-499487-000G4	Door Assy. (RH) (45 Series).....	1
25	00-499487-000G8	Door Assy. (RH) (65/85 Series).....	1
26	00-419653	Handle.....	2
27	RS-033-04	Rivet - Pop.....	4
28	00-499487-000G3	Door Assy. (LH) (45 Series).....	1
29	00-499487-000G7	Door Assy. (LH) (65/85 Series).....	1
30	00-427883-00001	Screen - Basket Support (45 Series).....	1
31	00-427883-00003	Screen - Basket Support (65 Series).....	1
32	00-427883-00004	Screen - Basket Support (85 Series).....	1
33	00-420769-00001	Bumper - Rubber.....	AR
34	00-497296-000G2	Magnet Assy.....	2
35	RS-033-04	Rivet - Pop.....	4
36	00-426806-000G2	Frame - Front Assy. (45 Series) (2 Units).....	1
37	00-426806-000G3	Frame - Front Assy. (45 Series) (3 Units).....	1
38	00-426806-000G5	Frame - Front Assy. (65/85 Series) (2 Units).....	1
39	00-426806-000G6	Frame - Front Assy. (65/85 Series) (3 Units).....	1
40	00-426806-000G7	Frame - Front Assy. (45 Series) (4 Units).....	1
41	00-957916-00005	Nameplate - Vulcan.....	2
42	00-427759-00001	Control - Interface.....	1
43	SD-024-40	Self-Tapping Screw 6-32 x 5/8 Phil. Pan Hd., Type TT.....	4
44	00-419317	Terminal - Stationary.....	1
45	SC-060-23	Mach. Screw 4-40 x 1/4 Slotted Rd. Hd.....	2
46	00-428541-00001	Plate - Control Mounting.....	1
47	00-428541-00002	Extension - Control (65/85 Series).....	1
48	00-428542-00002	Deflector Assy. (45 Series).....	1
49	00-428689-00002	Deflector Assy. (65/85 Series).....	1
50	00-409300-00005	Rod - Clean-Out.....	1
51	00-410863-00002	Strip - Grease (45/65 Series).....	1
52	00-410863-00006	Strip - Grease (85 Series).....	1
53	00-421756-00001	Brush - Fryer Cleaning.....	1

* Used if directly adjacent to the filter pan

** Used if not directly adjacent to the filter pan

- 19 00-497572-000G2 Pipe - Boil Out Bypass (Rev A)
- 20 00-497572-000G3 Pipe - Boil Out Bypass (Rev B)

PARTS NOT ILLUSTRATED

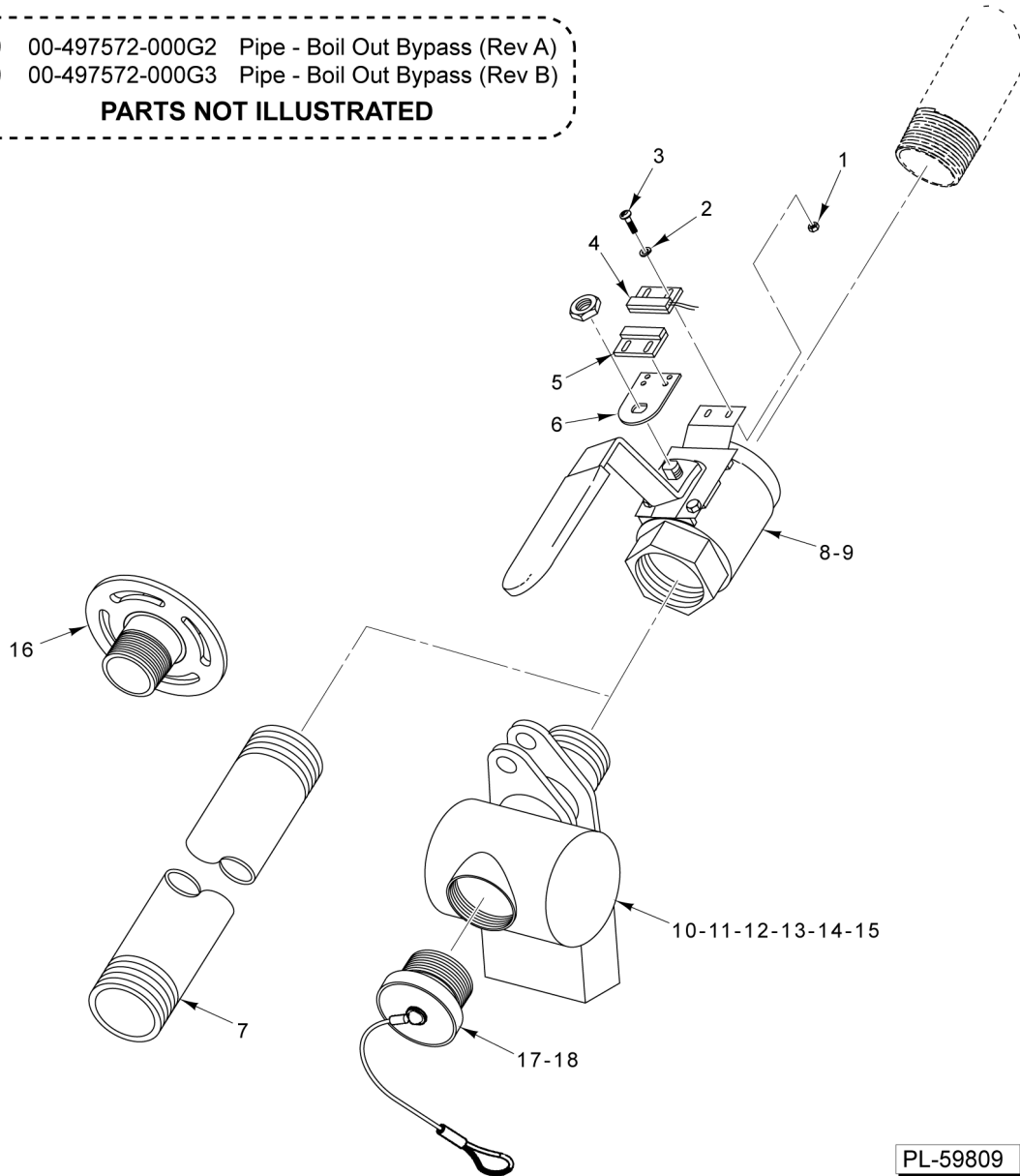

**DRAIN ASSEMBLY
(SINGLE UNIT)**

**DRAIN ASSEMBLY
(SINGLE UNIT)**

ILLUS. PL-59809	PART NO.	NAME OF PART	AMT.
1	NS-044-01	Nut Assy. 4-40 KEPS.....	4
2	WL-003-03	Lockwasher #4 Helical.....	4
3	SC-018-55	Mach. Screw 4-40 x 1/2 Phil. Pan Hd.....	4
4	00-426805-000G1	Switch Assy.....	1
5	00-426801-00002	Magnet - Switch Element Head.....	1
6	00-426798-00002	Plate - Switch.....	1
7	00-958713-00001	Pipe - Transition (No Filter).....	1
8	00-913111	Valve Assy. (1-1/4) (LH) (Incls. Items 1 thru 6) (Before 7/4/19).....	1
*9	00-976656-00002	Valve - Drain Assy. (1-1/4) (LH) (Incls. Items 1 thru 6) (Starting 7/4/19).....	1
**10	00-956829-000G2	Pipe - Drain (2-1/4 In.).....	1
*11	00-976518-00023	Pipe - Drain (3 In.).....	1
**12	00-420553-00002	Gasket - Silicone.....	1
*13	00-976617-00001	Gasket - Silicone.....	1
**14	00-420726-00003	Flange - Pipe (1-1/4) (Before 8/1/17).....	1
*15	00-976549	Flange - Pipe (Large) (8/1/17 thru 7/4/19).....	1
16	00-976693-00001	Drain Flange (Starting 7/4/19).....	1
**17	00-497571-000G1	Plug - Drain.....	1
*18	00-497571-000G2	Plug - Drain.....	1
**19	00-497572-000G2	Pipe - Boil Out Bypass.....	1
*20	00-497572-000G3	Pipe - Boil Out Bypass.....	1

* (Revision B - Manufactured after 8/1/17 with drain valve handle mounted at 10 o'clock position. The filter system drain manifolds are 3 In. diameter and painted red.)

** (Revision A - Manufactured before 8/1/17 with drain valve handle mounted at 12 o'clock position. The filter system drain manifolds are 2-1/4 In. diameter and painted black.)

36 00-497572-000G2 Pipe - Boil Out Bypass (Rev A)
 37 00-497572-000G3 Pipe - Boil Out Bypass (Rev B)
PARTS NOT ILLUSTRATED

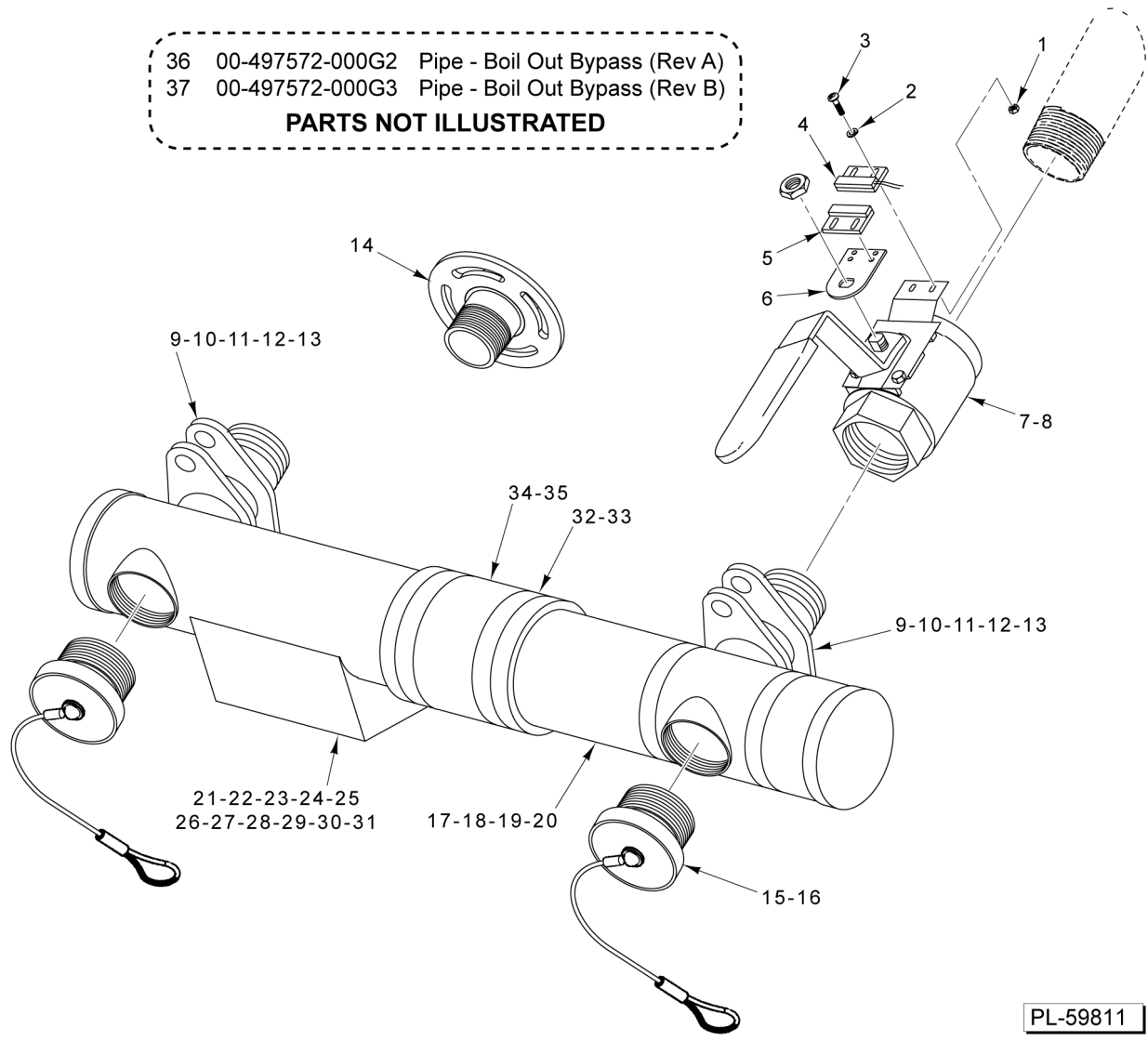

PL-59811

**DRAIN ASSEMBLY
 (MULTIPLE UNITS)**

DRAIN ASSEMBLY (MULTIPLE UNITS)

ILLUS. PL-59811	PART NO.	NAME OF PART	AMT.
1	NS-044-01	Nut Assy. 4-40 KEPS.....	4
2	WL-003-03	Lockwasher #4 Helical.....	4
3	SC-018-55	Mach. Screw 4-40 x 1/2 Phil. Pan Hd.....	4
4	00-426805-000G1	Switch Assy.....	1
5	00-426801-00002	Magnet - Switch Element Head.....	1
6	00-426798-00002	Plate - Switch.....	1
7	00-913111	Valve Assy. (1-1/4) (LH) (Incls. Items 1 thru 6) (Before 7/4/19).....	1
*8	00-976656-00002	Valve - Drain Assy. (1-1/4) (LH) (Incls. Items 1 thru 6) (Starting 7/4/19).....	1
*9	00-976617-00001	Gasket - Silicone.....	2
10	SC-036-13	Cap Screw 1/4-20 x 3/4 Hex Hd.....	4
**11	00-420553-00002	Gasket - Silicone.....	2
**12	00-420726-00003	Flange - Pipe (1-1/4) (Before 8/1/17).....	2
*13	00-976549	Flange - Pipe (Large) (8/1/17 thru 7/4/19).....	2
14	00-976693-00001	Drain Flange (Starting 7/4/19).....	1
**15	00-497571-000G1	Plug - Drain.....	2
*16	00-497571-000G2	Plug - Drain.....	2
**17	00-497566-000G1	Pipe - Drain (End) (45 Series).....	1
*18	00-976518-00013	Pipe - Drain (45 Series).....	1
**19	00-497566-000G4	Pipe - Drain (End) (65/85 Series).....	1
*20	00-976522-00013	Pipe - Drain (End) (65/85 Series).....	1
*21	00-976518-00A5V	Pipe - Drain (Entire Manifold) (45 Series) (2 Units).....	1
*22	00-976522-00A5V	Pipe - Drain With Spout (Entire Manifold) (65/85 Series) (2 Units).....	1
**23	00-497567-000G3	Pipe - Drain (End) With Spout (45 Series) (3 Units).....	1
*24	00-976518-00015	Pipe - Drain (45 Series) (3 Units).....	1
**25	00-497567-000G4	Pipe - LH Drain (End) With Spout (65/85 Series) (2 Units).....	1
*26	00-976518-00014	Pipe - Drain (Center) With Spout (45 Series) (4 Units).....	1
*27	00-976518-00015	Pipe - Drain (Center) With Spout (45 Series) (3 Units).....	1
**28	00-497569-000G4	Pipe - Drain (Center) With Spout (65/85 Series) (3 Units).....	1
*29	00-976522-00015	Pipe - Drain (Center) With Spout (65/85 Series) (3 Units).....	1
**30	00-497568-000G1	Pipe - Drain (Center) (45 Series) (4 Units).....	1
*31	00-976522-00014	Pipe - Drain (Center) With Spout (65/85 Series) (4 Units).....	1
**32	00-497409-00001	Clamp - Drain Tube (2-1/4 In.).....	AR
*33	00-497409-00002	Clamp - Drain Tube (3 In.).....	AR
**34	00-419351-00001	Hose - Connect.....	AR
*35	00-419351-00002	Hose - Connect.....	AR
**36	00-497572-000G2	Pipe - Boil Out Bypass.....	1
*37	00-497572-000G3	Pipe - Boil Out Bypass.....	1

* (Revision B - Manufactured after 8/1/17 with drain valve handle mounted at 10 o'clock position. The filter system drain manifolds are 3 In. diameter and painted red.)

** (Revision A - Manufactured before 8/1/17 with drain valve handle mounted at 12 o'clock position. The filter system drain manifolds are 2-1/4 In. diameter and painted black.)

23	00-521820	U-Bolt
24	NS-046-52	Nut Assy. 1/4-20 Hex
25	00-422281-00007	Hose - Discard (6 Ft.)
26	00-422281-00008	Hose - Discard (4 Ft.)
27	00-958681-00001	Support - Oil Return
28	00-428914-000G1	Harness - Pump
29	00-497320-00002	Harness - Extension (Filter Switch)
30	00-422304-000G5	Harness - Bat. Interplumb W/R
31	00-422297-000G1	Harness - Branch (D)
32	00-422299-000G1	Harness (Y)

PARTS NOT ILLUSTRATED

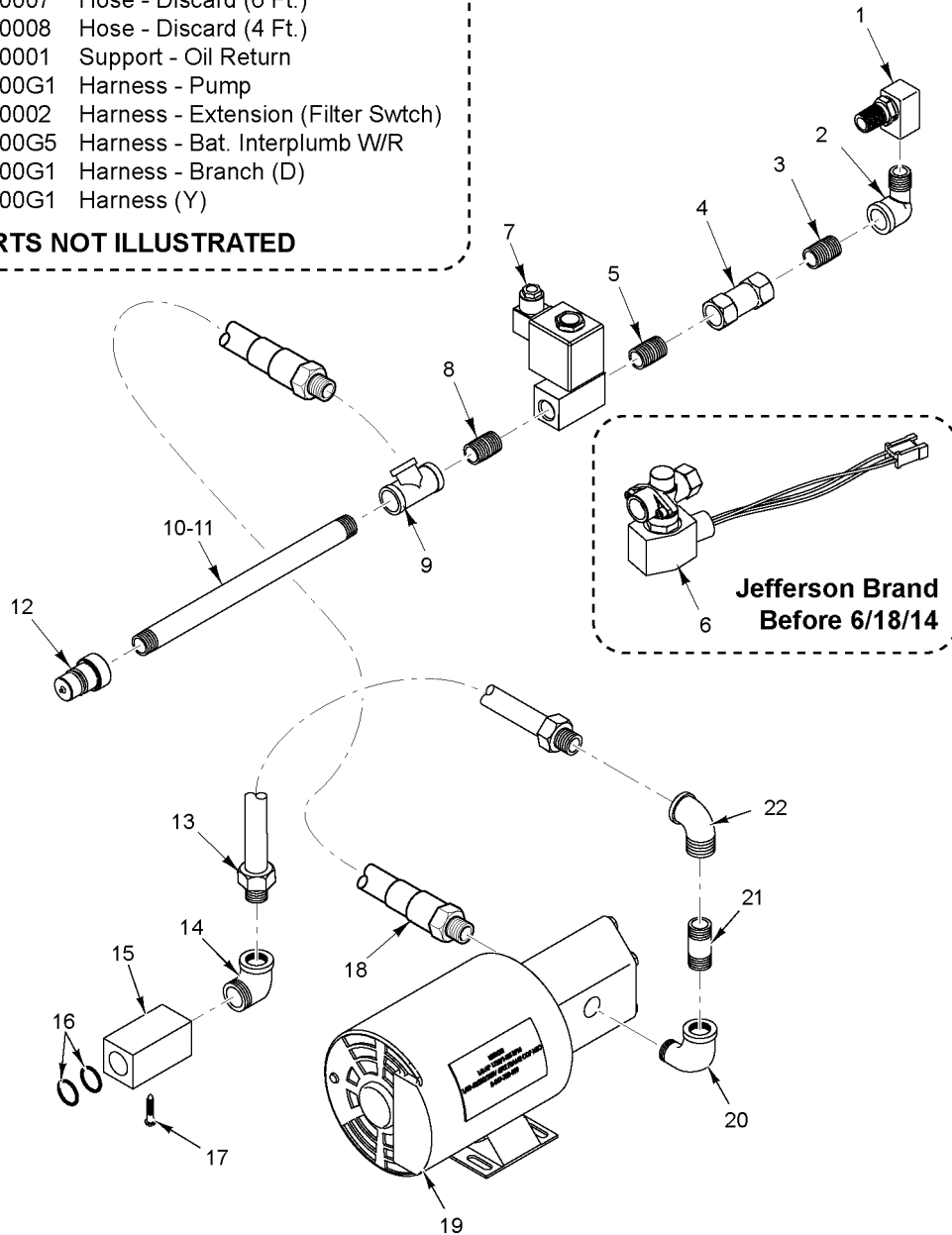

PL-59812

**OIL RETURN
(SINGLE UNIT)**

OIL RETURN (SINGLE UNIT)

ILLUS. PL-59812	PART NO.	NAME OF PART	AMT.
1	00-419251-00001	Fitting - 90 Deg. Swivel.....	1
2	FP-013-17	Elbow - Street 1/2 x 90 Deg.....	1
3	FP-035-91	Pipe 1/2 x 1-1/8 TBE.....	1
4	00-418786-00001	Valve - Check.....	1
5	FP-035-91	Pipe 1/2 x 1-1/8 TBE.....	1
6	00-428691-00002	Valve - Solenoid (120 V.) (Jefferson Brand) (Before 6/18/14).....	1
7	00-959909-00001	Valve - Solenoid (120 V.) (Bacarra Brand) (Starting 6/18/14).....	1
8	FP-035-91	Pipe 1/2 x 1-1/8 TBE.....	1
9	FP-019-25	Tee 1/2 x 1/2 x 1/2.....	1
10	FP-085-79	Pipe 1/2 x 14-1/4 TBE.....	1
11	FP-090-79	Pipe 1/2 x 19 TBE.....	1
12	00-418781-00001	Quick Disconnect.....	1
13	00-426602-00004	Tube - Flex (19 In.).....	1
14	FP-013-17	Elbow - Street 1/2 x 90 Deg.....	1
15	00-426567-00003	Receptacle - Oil Suction.....	1
16	00-426567-00002	O-Ring (Viton).....	2
17	SC-114-01	Mach. Screw 10-32 x 3/8 Hex Washer Hd.....	2
18	00-426602-00001	Tube - Flex (12 In.).....	1
19	00-417792-00008	Pump Motor Assy. (115/230 V., 60 Hz.) (8 G.P.M.).....	1
20	FP-077-68	Elbow 1/2 x 90 Deg.....	1
21	FP-035-95	Pipe 1/2 x 2 TBE.....	1
22	FP-077-68	Elbow 1/2 x 90 Deg.....	1
23	00-521820	U-Bolt.....	1
24	NS-046-52	Nut Assy. 1/4-20 Hex.....	2
25	00-422281-00007	Hose - Discard (6 Ft.).....	AR
26	00-422281-00008	Hose - Discard (4 Ft.).....	AR
27	00-958681-00001	Support - Oil Return.....	1
28	00-428914-000G1	Harness - Pump.....	1
29	00-497320-00001	Harness - Extension (Filter Switch).....	1
30	00-422304-000G5	Harness - Bat. Interplumb W/R.....	1
31	00-422297-000G1	Harness - Brand (D).....	1
32	00-422299-000G1	Harness (Y).....	1

22	00-521820	U-Bolt
23	NS-046-52	Nut Assy. 1/4-20 Hex
24	00-422281-00007	Hose - Discard (6 Ft.)
25	00-422281-00008	Hose - Discard (4 Ft.)
26	00-958681-00001	Support - Oil Return
27	00-428914-000G1	Harness - Pump
28	00-497320-00002	Harness - Extension (Filter Switch)
29	00-422304-000G7	Harness - Bat. Interplumb W/R
30	00-422304-000G8	Harness - Bat. Interplumb W/R
31	00-422297-000G1	Harness - Branch (D)
32	00-422298-000G1	Harness (T)

PARTS NOT ILLUSTRATED

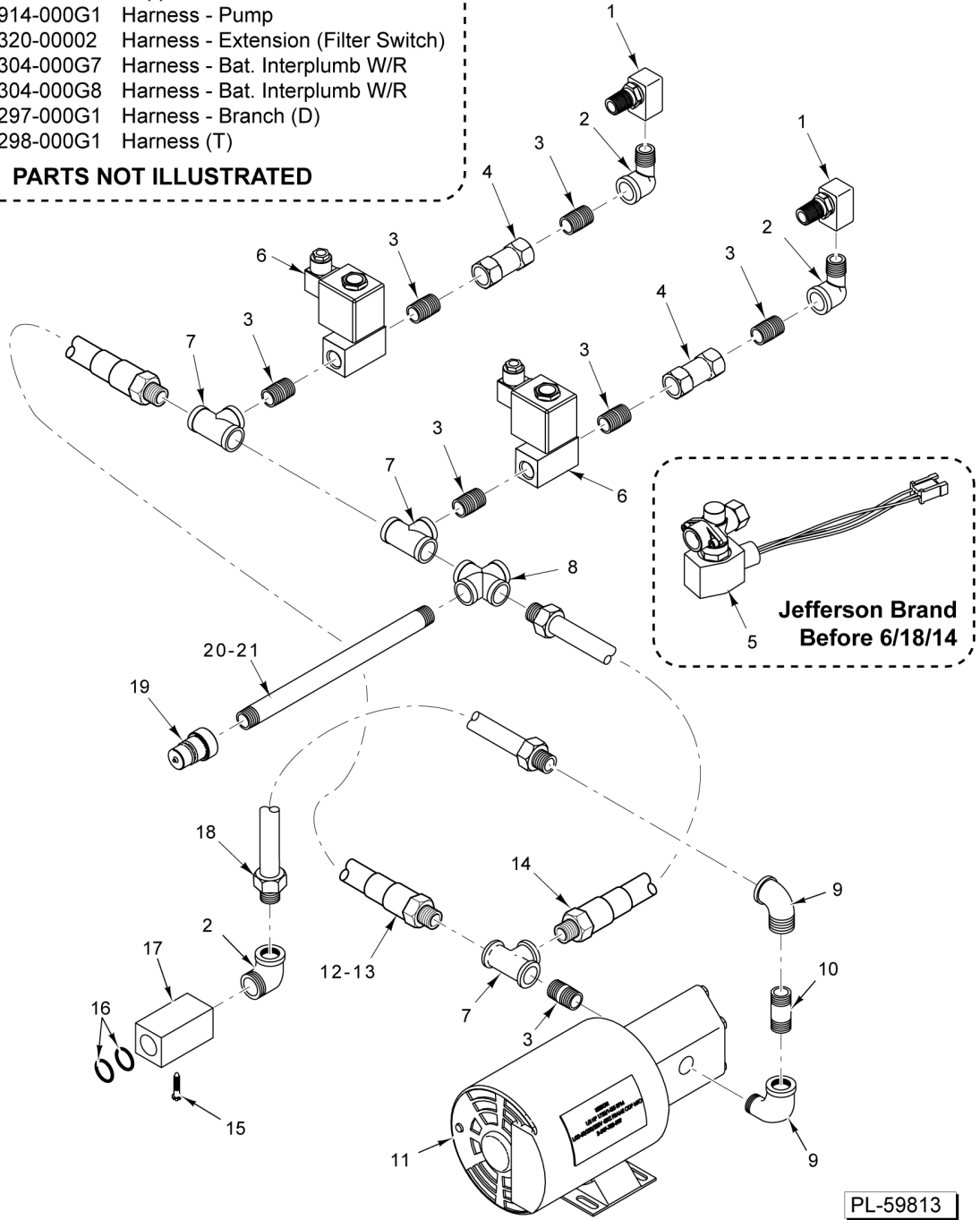

PL-59813

**OIL RETURN
(MULTIPLE UNITS)**

OIL RETURN (MULTIPLE UNITS)

ILLUS. PL-59813	PART NO.	NAME OF PART	AMT.
1	00-419251-00001	Fitting - 90 Deg. Swivel.....	2
2	FP-013-17	Elbow - Street 1/2 x 90 Deg.....	3
3	FP-035-91	Pipe 1/2 x 1-1/8 TBE.....	7
4	00-418786-00001	Valve - Check.....	2
5	00-428691-00002	Valve - Solenoid (120 V.) (Jefferson Brand) (Before 6/18/14).....	2
6	00-959909-00001	Valve - Solenoid (120 V.) (Bacarra Brand) (Starting 6/18/14).....	2
7	FP-019-25	Tee 1/2 x 1/2 x 1/2.....	3
8	FP-034-01	Pipe - Cross 1/2 NPT.....	1
9	FP-077-68	Elbow 1/2 x 90 Deg.....	2
10	FP-035-95	Pipe 1/2 x 2 TBE.....	1
11	00-417792-00008	Pump Motor Assy. (115/230 V., 60 Hz.) (8 G.P.M.).....	1
12	00-426602-00001	Tube - Flex (12 In.).....	1
13	00-426602-00004	Tube - Flex (19 In.).....	1
14	00-426602-00001	Tube - Flex (12 In.).....	1
15	SC-114-01	Mach. Screw 10-32 x 3/8 Hex Washer Hd.....	2
16	00-426567-00002	O-Ring (Viton).....	2
17	00-426567-00003	Receptacle - Oil Suction.....	1
18	00-426602-00002	Tube - Flex (29 In.).....	1
19	00-418781-00001	Quick Disconnect.....	1
20	FP-085-79	Pipe 1/2 x 14-1/4 TBE.....	1
21	FP-090-79	Pipe 1/2 x 19 TBE.....	1
22	00-521820	U-Bolt.....	1
23	NS-046-52	Nut Assy. 1/4-20 Hex.....	2
24	00-422281-00007	Hose - Discard (6 Ft.).....	AR
25	00-422281-00008	Hose - Discard (4 Ft.).....	AR
26	00-958681-00001	Support - Oil Return.....	1
27	00-428914-000G1	Harness - Pump.....	1
28	00-497320-00002	Harness - Extension (Filter Switch).....	1
29	00-422304-000G7	Harness - Bat. Interplumb W/R.....	1
30	00-422304-000G8	Harness - Bat. Interplumb W/R.....	1
31	00-422297-000G1	Harness - Brand (D).....	1
32	00-422298-000G1	Harness (T).....	1

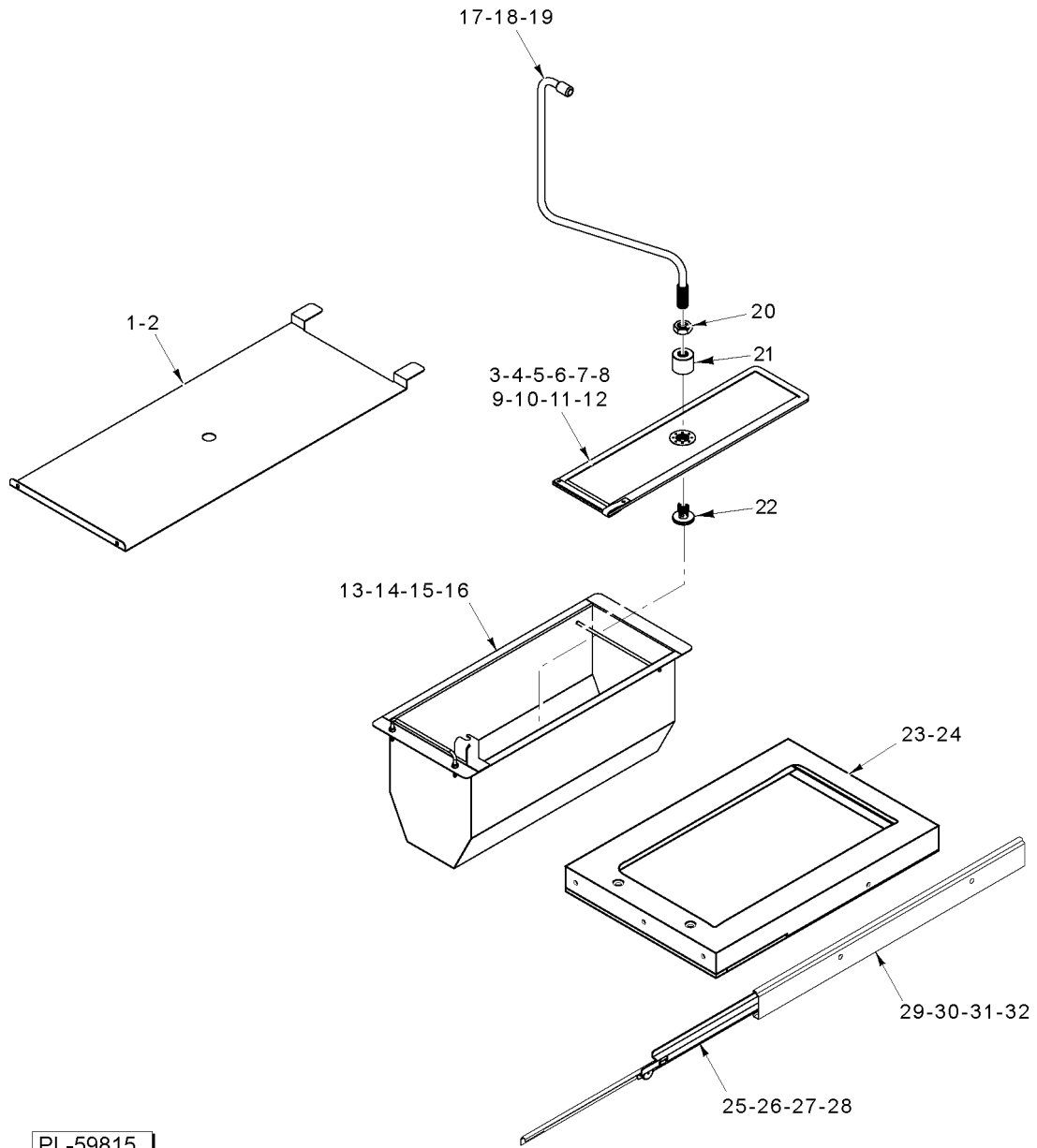

**FILTER ASSEMBLY
(SINGLE UNIT)**

FILTER ASSEMBLY (SINGLE UNIT)

ILLUS. PL-59815	PART NO.	NAME OF PART	AMT.
1	00-956904-00001	Splash Guard (11 x 22 In.) (45 Series).....	1
2	00-956904-00002	Splash Guard (16-1/2 x 22 In.) (65/85 Series).....	1
3	00-499087-00002	Screen - Fine Mesh Filter (Metal) (22 x 5 In.) (45 Series)	1
4	00-499087-00004	Screen - Fine Mesh Filter (Metal) (22 x 10-1/2 In.) (65/85 Series)	1
5	00-499085-00003	Insert - Filter Screen (2-1/4 x 19 In.) (45 Series).....	1
6	00-499085-00005	Insert - Fabric Envelope (3-3/4 x 22 In.) (45 Series).....	1
7	00-499085-00006	Insert - Fabric Envelope (9-1/4 x 22 In.) (65/85 Series).....	1
8	00-499085-00007	Insert - Filter Screen (7-3/4 x 19 In.) (65/85 Series).....	1
9	00-499086-00002	Filter - Envelope (23.5 x 5) (45 Series).....	1
10	00-499086-00003	Filter - Envelope (23.5 x 10.5) (65/85 Series).....	1
11	00-499089-00002	Clip - Filter, Envelope (5 In. Lg.) (45 Series).....	1
12	00-499089-00003	Clip - Filter, Envelope (10-1/2 In. Lg.) (65/85 Series).....	1
13	00-958000-000G5	Pan Assy. - Filter (11-1/8 Tall) (45 Series).....	1
14	00-958000-000G11	Pan Assy. - Filter (10-1/4 Tall) (45 Series).....	1
15	00-958000-000G6	Pan Assy. - Filter (11-1/8 Tall) (65/85 Series).....	1
16	00-958000-000G12	Pan Assy. - Filter (10-1/4 Tall) (65/85 Series).....	1
17	00-499081-00G10	Tube - Suction (Used With Item 13 & 15).....	1
18	00-956901-00G11	Suction Tube Assy. (Incls. Items 21 & 22) (Used With Item 13 & 15).....	1
19	00-956901-00G23	Suction Tube Assy. (Incls. Items 21 & 22) (Used With Item 14 & 16).....	1
20	NS-017-49	Jam Nut 3/4-16 Hex.....	1
21	00-499083-00002	Coupling - Suction.....	1
22	00-499084-00002	Knob - Port Suction.....	1
23	00-956907-000G3	Top - Counter Assy. (9.875 x 24 Cutout) (45 Series).....	1
24	00-956907-000G4	Top - Counter Assy. (15.375 x 24 Cutout) (65/85 Series).....	1
25	00-958026-00008	Roller (RH) (27-1/2 In.).....	1
26	00-958026-00002	Roller (RH) (21-1/2 In.).....	1
27	00-958026-00011	Roller (LH) (27-1/2 In.).....	1
28	00-958026-00005	Roller (LH) (21-1/2 In.).....	1
29	00-958026-000G3	Guide - Cabinet (RH) (21-1/2 In.).....	1
30	00-958026-000G5	Guide - Cabinet (RH) (27-1/2 In.).....	1
31	00-958026-000G4	Guide - Cabinet (LH) (21-1/2 In.).....	1
32	00-958026-000G6	Guide - Cabinet (LH) (27-1/2 In.).....	1

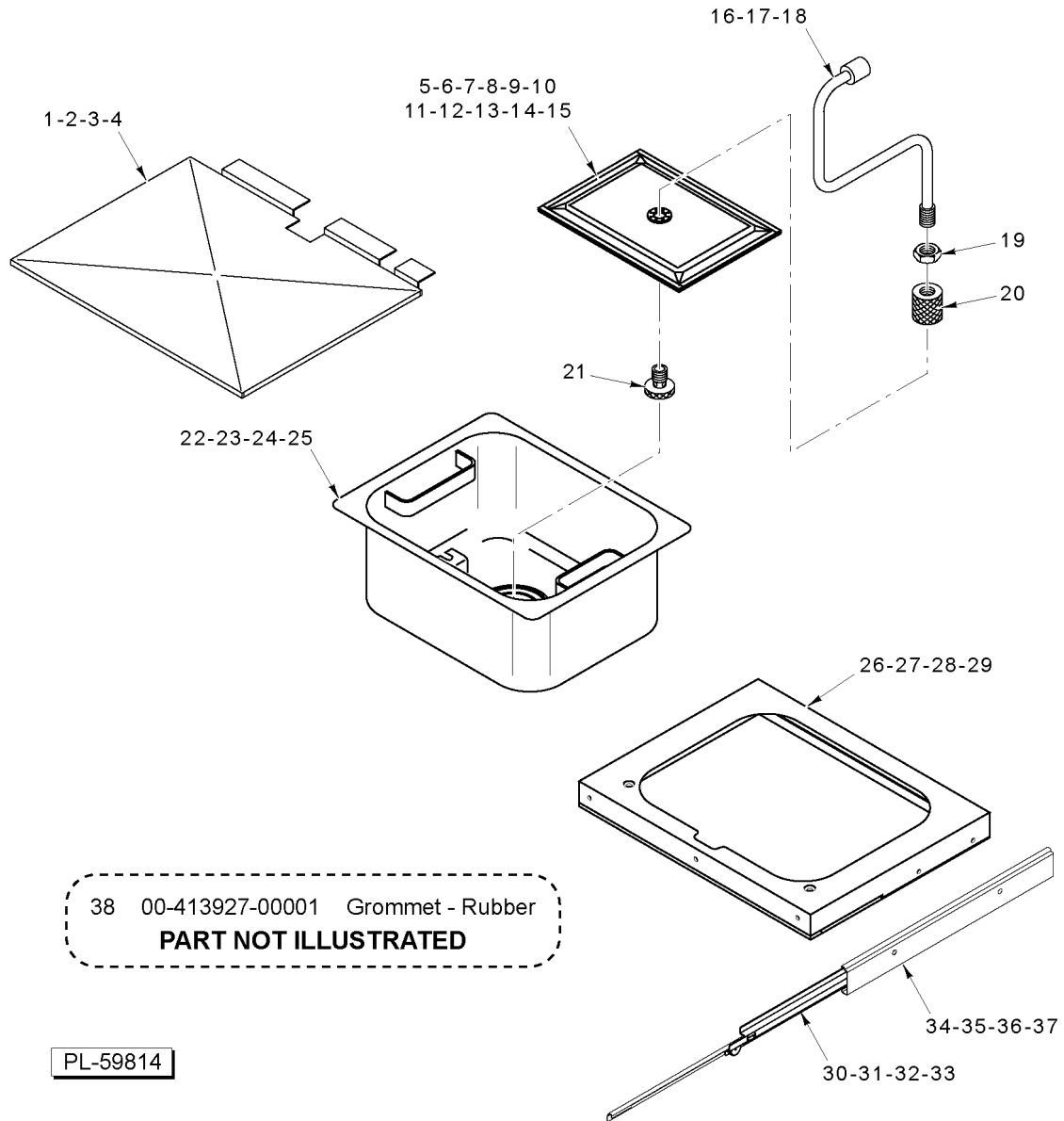

**FILTER ASSEMBLY
(MULTIPLE UNITS)**

**FILTER ASSEMBLY
(MULTIPLE UNITS)**

ILLUS. PL-59814	PART NO.	NAME OF PART	AMT.
1	00-428518-00001	Splash Guard (25.25 x 22.125) (45 Series).....	1
2	00-956904-00001	Splash Guard (11 x 22 In.) (45 Series).....	1
3	00-428519-00001	Splash Guard (36.25 x 22.125) (65/85 Series).....	1
4	00-956904-00002	Splash Guard (16-1/2 x 22 In.) (45/65/85 Series).....	1
5	00-499087-00002	Screen - Fine Mesh Filter (Metal) (22 x 5 In.).....	1
6	00-499087-00003	Screen - Fine Mesh Filter (Metal) (16 x 12-1/2 In.).....	1
7	00-499087-00004	Screen - Fine Mesh Filter (Metal) (22 x 10-1/2 In.).....	1
8	00-499085-00002	Insert - Fabric Envelope (11 x 15 In.).....	1
9	00-499085-00003	Insert - Filter Screen (2-1/4 x 19 In.).....	1
10	00-499085-00004	Insert - Filter Screen (10-1/2 x 13-1/2 In.).....	1
11	00-499085-00005	Insert - Fabric Envelope (3-3/4 x 22 In.).....	1
12	00-499085-00006	Insert - Fabric Envelope (9-1/4 x 22 In.).....	1
13	00-499085-00007	Insert - Filter Screen (7-3/4 x 19 In.).....	1
14	00-499089-00002	Clip - Filter, Envelope (5 In. Lg.).....	1
15	00-499089-00003	Clip - Filter, Envelope (10-1/2 In. Lg.).....	1
16	00-499081-000G3	Tube - Suction (Used With Item 22 & 24).....	1
17	00-499092-000G1	Suction Tube Assy. (Incls. Items 19 & 20) (Used With Items 22 & 24).....	1
18	00-956901-00G23	Suction Tube Assy. (Incls. Items 19 & 20) (Used With Items 23 & 25).....	1
19	NS-017-49	Jam Nut 3/4-16 Hex.....	1
20	00-499083-00002	Coupling - Suction.....	1
21	00-499084-00002	Knob - Port Suction.....	1
22	00-497374-000G1	Vessel Assy. (23 x 16 Bottom) (45 Series).....	1
23	00-958000-00G11	Pan Assy. - Filter (10-1/4 Tall) (23.5 x 5.25 Bottom) (45 Series).....	1
24	00-497374-000G2	Vessel Assy. (28 x 16 Bottom) (65/85 Series).....	1
25	00-958000-00G12	Pan Assy. Filter (23.5 x 10.75 Bottom) (45/65/85 Series).....	1
26	00-956907-000G1	Top - Counter (21 x 17 Cutout) (45 Series).....	1
27	00-956907-000G3	Top - Counter Assy. (24 x 9.875 Cutout) (45 Series).....	1
28	00-956907-000G2	Top - Counter (29-1/4 x 17 Cutout) (65/85 Series).....	1
29	00-956907-000G4	Top - Counter Assy. (24 x 15.375 Cutout) (45/65/85 Series).....	1
30	00-958026-00002	Roller (RH) (21-1/2 In.).....	1
31	00-958026-00008	Roller (RH) (27-1/2 In.).....	1
32	00-958026-00005	Roller (LH) (21-1/2 In.).....	1
33	00-958026-00011	Roller (LH) (27-1/2 In.).....	1
34	00-958026-000G3	Guide - Cabinet (RH) (21-1/2 In.).....	1
35	00-958026-000G5	Guide - Cabinet (RH) (27-1/2 In.).....	1
36	00-958026-000G4	Guide - Cabinet (LH) (21-1/2 In.).....	1
37	00-958026-000G6	Guide - Cabinet (LH) (27-1/2 In.).....	1
38	00-413927-00001	Grommet - Rubber.....	1

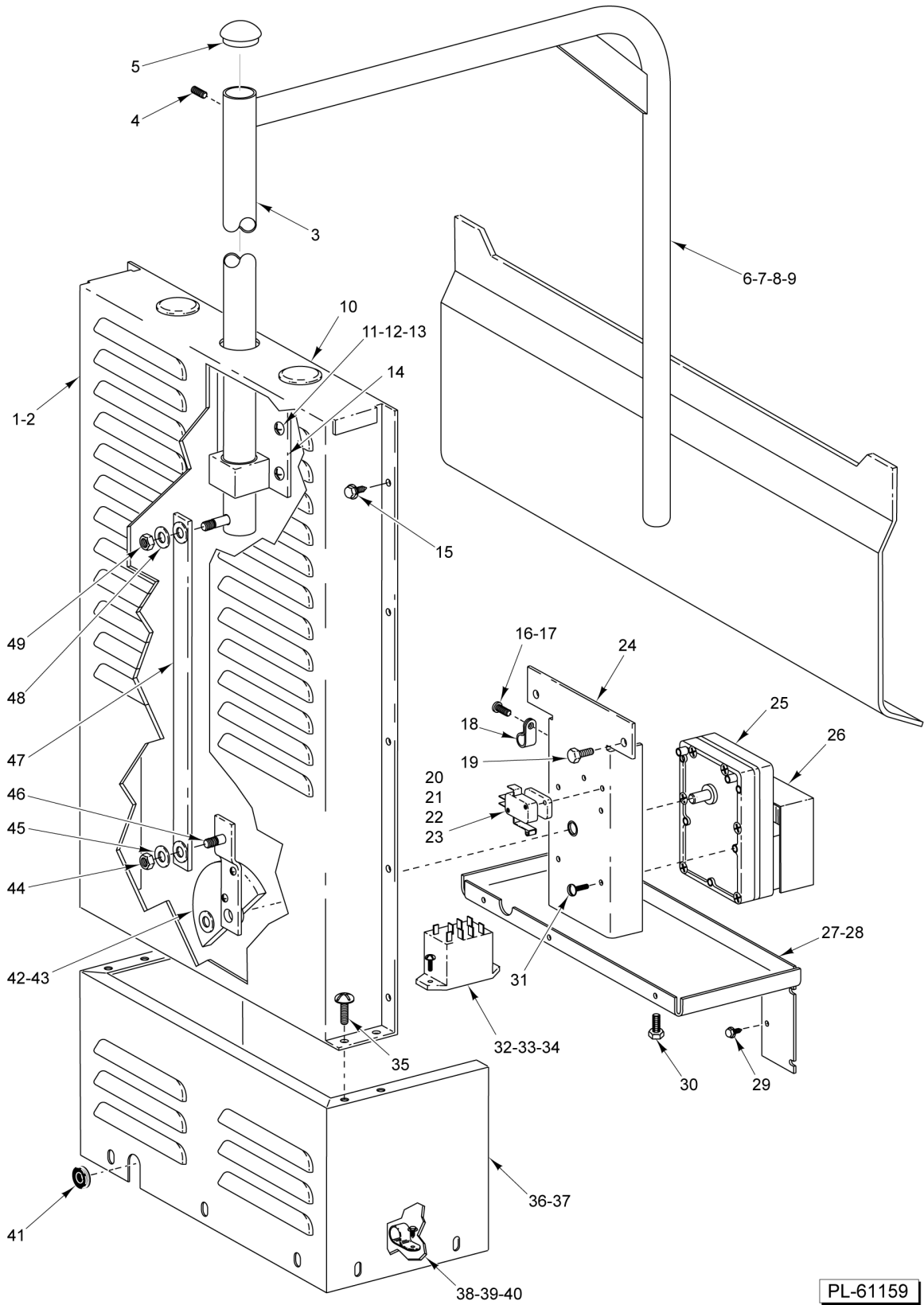

PL-61159

BASKETLIFT COMPONENTS

BASKETLIFT COMPONENTS

ILLUS.	PART NO.	NAME OF PART	AMT.
PL-61159			
1	00-418481-00001	Wrap - Top (45 Series).....	1
2	00-418511-00001	Wrap - Top (65/85 Series).....	1
3	00-418503-00001	Tube - Basketlift.....	1
4	SC-088-40	Set Screw 5/16-24 x 1/4 Hex Hdls., Cup Pt.....	1
5	PB-004-04	Plug Button (1-1/4).....	1
6	00-956914-00G10	Arm - Basket Assy. (Single) (45/65 Series).....	1
7	00-956914-00G2	Arm - Basket Assy. (Single) (85 Series).....	1
8	00-956914-00G11	Arm - Basket Assy. (Double) (45/65 Series).....	1
9	00-956914-00G3	Arm - Basket Assy. (Double) (85 Series).....	1
10	PB-004-04	Plug Button (1-1/4).....	2
11	SD-032-07	Self-Tapping Screw 10-24 x 1/2 Hex Washer Hd., Type TT.....	2
12	WS-004-33	Washer.....	6
13	NS-047-73	Lock Nut 5/16-18 Hex.....	6
14	00-418478-000G1	Bearing Support Assy.....	1
15	SD-036-03	Self-Tapping Screw 8-18 x 3/8 Hex Washer Hd., Type AB.....	10
16	SC-109-10	Mach. Screw 6-32 x 3/8 Slotted Pan Hd. (SST).....	1
17	NS-009-07	Nut 6-32 Hex.....	1
18	00-078752-00012	Clamp - Cable.....	1
19	SC-037-80	Cap Screw 10-24 x 1/2 Hex Hd.....	8
20	NS-009-02	Nut 4-40 Hex.....	2
21	SC-112-90	Mach. Screw 4-40 x 1 Slotted Pan Hd.....	2
22	00-411496-000F3	Microswitch.....	1
23	00-418159-00001	Block - Cam Switch.....	1
24	00-418123-000G1	Plate - Motor.....	1
25	00-418156-00001	Gear - Motor (115 V., 60 Hz.).....	1
26	00-418517-00001	Shroud - Motor.....	1
27	00-418484-00001	Base - Motor Mounting (45 Series).....	1
28	00-418513-00001	Base - Motor Mounting (65/85 Series).....	1
29	SD-032-07	Self-Tapping Screw 10-24 x 1/2 Hex Washer Hd., Type TT.....	2
30	SC-037-80	Cap Screw 10-24 x 1/2 Hex Hd.....	2
31	SC-018-47	Mach. Screw 10-32 x 3/4 Slotted Pan Hd.....	4
32	00-416535-00004	Switch - Relay S.P.D.T. 24 V.....	1
33	SC-109-10	Mach. Screw 6-32 x 3/8 Slotted Pan Hd. (SST).....	3
34	NS-009-07	Nut 6-32 Hex.....	3
35	SD-036-03	Self-Tapping Screw 8-18 x 3/8 Hex Washer Hd., Type AB.....	4
36	00-418480-00001	Wrap - Bottom (45 Series).....	1
37	00-418510-00001	Wrap - Bottom (65/85 Series).....	1
38	00-078752-00012	Clamp - Cable.....	1
39	SC-109-10	Mach. Screw 6-32 x 3/8 Slotted Pan Hd. (SST).....	1
40	NS-009-07	Nut 6-32 Hex.....	1
41	00-418482-00001	Grommet.....	1
42	00-418475-000G1	Crank - Arm Assy.....	1
43	SC-055-02	Set Screw 1/4-20 x 1/4 Hdls., Cup Pt. (SST).....	2
44	NS-047-73	Lock Nut 5/16-18 Hex.....	1
45	WS-004-33	Washer.....	1
46	SD-015-41	Self-Tapping Screw 8-32 x 1/2 Phil. Pan Hd., Type TT.....	2
47	00-418477-000G1	Coupler Assy.....	1
48	WS-004-33	Washer.....	1
49	NS-047-73	Lock Nut 5/16-18 Hex.....	1

