



# ***INSTALLATION & OPERATION MANUAL***

## **FOOD HOLDING & TRANSPORTATION CABINETS**

### **MODELS:**

**1220-3-BC  
1220-7  
1220-8-BC  
1220-15-BC  
1220-20-BC  
1826-5-BC-IS  
1826-7-BC-IS  
1826-7-DBL-IS  
1826-7-SCH  
1826-13-BC-IS  
1826-15-BC-IS  
1826-15-SCH  
2-90  
2-96  
2-150  
580**



## **IMPORTANT FOR YOUR SAFETY**

**THIS MANUAL HAS BEEN PREPARED FOR PERSONNEL QUALIFIED TO INSTALL ELECTRICAL EQUIPMENT, WHO SHOULD PERFORM THE INITIAL FIELD START-UP AND ADJUSTMENTS OF THE EQUIPMENT COVERED BY THIS MANUAL.**

### **FOR YOUR SAFETY**

**DO NOT STORE OR USE GASOLINE OR OTHER FLAMMABLE VAPORS OR LIQUIDS IN THE VICINITY OF THIS OR ANY OTHER APPLIANCE.**

### **WARNING**

**Improper installation, adjustment, alteration, service, or maintenance can cause property damage, injury, or death.**

**Read the installation, operating and maintenance instructions thoroughly before installing or servicing equipment.**

**IN THE EVENT OF A POWER FAILURE,**

**DO NOT ATTEMPT TO OPERATE THIS DEVICE.**

# TABLE OF CONTENTS

<b>IMPORTANT FOR YOUR SAFETY</b> .....	<b>1</b>
<b>GENERAL</b> .....	<b>3</b>
INTRODUCTION .....	<b>3</b>
INSTALLATION .....	<b>3</b>
ELECTRICAL REQUIREMENTS .....	<b>4</b>
<b>OPERATION</b> .....	<b>5</b>
CONTROLS .....	<b>5</b>
OPERATING INSTRUCTIONS .....	<b>6</b>
CLEANING .....	<b>6</b>
STAINLESS STEEL CARE .....	<b>7</b>
MAINTENANCE .....	<b>8</b>
<b>LOCKOUT / TAGOUT PROCEDURE</b> .....	<b>9</b>
<b>TROUBLESHOOTING</b> .....	<b>10</b>
<b>SERVICE &amp; PARTS INFORMATION</b> .....	<b>10</b>
<b>WIRING DIAGRAMS</b> .....	<b>11 – 15</b>
<b>WARRANTY</b> .....	<b>16</b>

# GENERAL

## INTRODUCTION

Wittco Holding & Transport Cabinets are produced with quality workmanship and material. Proper installation, usage, and maintenance of your cabinet will result in many years of satisfactory performance.

It is suggested that you thoroughly read this entire manual and carefully follow all of the instructions provided.

Wittco Holding & Transport Cabinets provide an efficient means of transporting and holding bulk prepared foods at proper serving temperatures.

## INSTALLATION

Before installing, verify that the electrical service agrees with the specifications on the rating plate located on the lower back corner of the cabinet. If the supply and equipment requirements do not agree, do not proceed with unpacking and installation, Contact Wittco Customer Service Department immediately. (Fig. 2)

### **UNPACKING:**

The Cabinet was inspected before leaving the factory. The transportation company assumes full responsibility for safe delivery upon acceptance of the shipment. Immediately after unpacking, check for possible shipping damage to the cabinet.

***If the cabinet is found to be damaged, save the packaging material and contact the carrier within 15 days of delivery.***

Carefully unpack and place in a work accessible area as near the installation position as possible.

1. Open the door and carefully remove any packaging materials and the retaining straps that hold the wire plate racks (Banquet Carts) or the tray slides and tray slide upright side supports (Holding & Transport Cabinets).
2. Peel off vinyl protection film.
3. **1826-7-DBL-IS ONLY:**  
This cabinet is simply two (2) 1826-7-IS cabinets stacked on top of each other. One (1) cabinet will come with casters and a stacking assembly on top. The other cabinet is without casters. This cabinet requires two people to lift and should be placed inside the stacking kit that was shipped with the bottom cabinet. Stacking kits fit only one way between the cabinets. If for any reason either one or both cabinets do not fit within the stacking kit provided, please contact the service department at 414-434-4716.

4. Remove cardboard element cover protector from cabinet bottom.  
Remove adjustable tray slides from box.  
Remove the tray slide supports and install them in the cabinet.
  - a. Hook the openings in the flat flange of the support over two vertical carriage bolts on the interior of the cabinet.
  - b. Make sure all flanges on the four supports face the door opening.
 Install tray slides in the cabinet.  
Make sure the hook on the end of the tray slide is up. (Fig. 1)



(Fig. 1)

**CLEANING:**

**The cabinet should be thoroughly cleaned prior to putting into service.**

Use a mild soap and water solution to clean the interior of the unit. Never use harsh chemicals or abrasive pads to clean the unit. **Refer to cleaning instructions on page 6 of this manual.**

**LOCATION:**

For efficient cabinet operation, choose a location that will provide easy loading and unloading without interfering with the final assembly of food orders.

The installation location must allow adequate clearances for servicing and proper operation.

## ELECTRICAL REQUIREMENTS

**ELECTRICAL CODES & STANDARDS:**

The cabinet must be installed in accordance with:

**In the United States of America:**

1. State and Local Codes.
2. National Electrical Code, ANSI/NFPA-70 (latest edition.) Copies may be obtained from: The National Fire Protection Association, 1 Batterymarch Park, Quincy, MA 02269.  
1-617-770-3000 [www.nfpa.org](http://www.nfpa.org)

**In Canada:**

1. Local Codes.
2. Canadian Electrical Code, CSA C22.1 (latest edition.) Copies

may be obtained from: The Canadian Standard Association.  
[www.csa.ca](http://www.csa.ca)

**ELECTRICAL CONNECTIONS:**

The cabinet is factory wired for either 110/120 volt or 208/240 volt, single phase operation. All 110/120 volt cabinets are equipped with a 8 foot cord and NEMA 5-15 plug as standard equipment. All 208/240 volt cabinets are equipped with a 8 foot cord and NEMA 6-15 plug. Refer to wiring diagrams in the back of this manual.

The cord and plug supplied is a suitable durable cord with a molded three-prong plug, and is provided with a proper strain relief.

**⚠ WARNING** All cabinets are equipped with a three-prong plug. It is imperative that this plug must be connected into a properly grounded three-prong receptacle. If the receptacle is not the proper grounding type, contact an electrician. *Do not remove the grounding prong from this plug.*

Verify that the power source matches the Serial Data Plate located on the lower back corner of the cabinet and the plug configuration before connection is made.

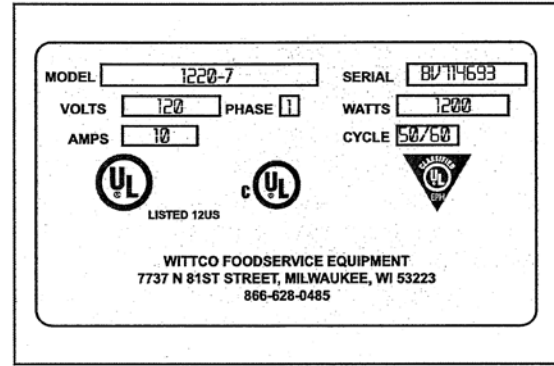

(Fig.2)

## OPERATION

### CONTROLS

**⚠ WARNING** The Cabinet and its parts are hot. Be very careful when operating, cleaning, or servicing the cabinet.

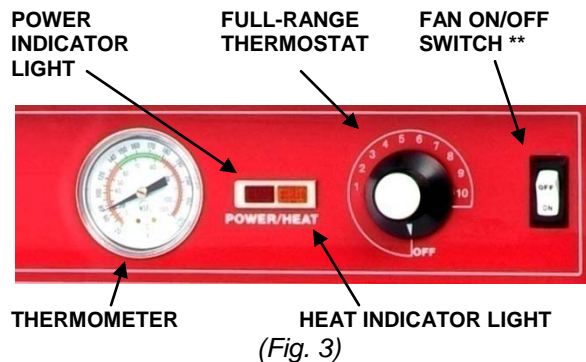

(Fig. 3)

#### Power Indicator Light:

The Red Power Indicator Light indicates power is supplied to the cabinet. The red light will stay lit as long as the cabinet is plugged in.

#### Heat Indicator Light:

The Amber Heat Indicator Light indicates the heating element(s) are heating. The amber light will stay lit as

long as the heating element(s) are engaged. Once the predetermined temperature is achieved, the heating element(s) will begin to cycle. During this period, the amber light will turn on and off.

#### Fan On/Off Switch:

##### \*\* Models manufactured after 2010

The Fan On/Off Switch turns the fan on only. The use of the fan is optional. Turn on fan if forced air holding is desired.

#### Thermometer:

The Thermometer indicates the interior temperature of the cabinet.

#### Thermostat:

The Thermostat turns power on to the heating element(s). The thermostat setting is from 1 to 10. The greater the thermostat setting number, the higher the temperature. (Fig. 4)

***It is recommended that prior to placing the cabinet in operation, that it be preheated at the highest temperature setting for a period of 30 to 45 minutes.***

**The operator should always monitor the food product to insure that it remains at a proper temperature.**

Thermostat Setting	Approximate Temperature
1	100°F (37°C)
2	110°F (43°C)
3	120°F (49°C)
4	130°F (54°C)
5	140°F (60°C)
6	150°F (66°C)
7	160°F (71°C)
8	170°F (77°C)
9	180°F (82°C)
10	190°F (88°C)

(Fig. 4)

## OPERATING INSTRUCTIONS

**⚠ WARNING** The Cabinet and its parts are hot. Be very careful when operating, cleaning, or servicing the cabinet.

Once the cabinet has been connected to the appropriate power source, the cabinet is ready for operation. Begin by turning the thermostat dial to the number **5**. This will cause the heating element(s) to start heating. Once the red light is lit, the thermostat dial can be turned to the desired setting.

When cooking is completed, turn the thermostat dial to the OFF position.

### HUMIDITY PAN (Option)

The humidity pan is designed to provide additional humidity to the holding cabinet interior when required. *It is suggested that the humidity pan only be used when a moist environment is required.*

- The humidity pan should only be used when filled with water.** Using the humidity pan without water will damage the black non-spill sponge material.
- Place the humidity pan directly on the bottom of the cabinet and fill with water. While in use monitor the humidity pan and refill when necessary.
- Remove humidity pan when not in use or when transporting cabinet.**

**CLEANING**

**⚠ WARNING** Always *unplug electrical power supply* before cleaning.

**⚠ WARNING** The Cabinet and its parts are hot. Be very careful when operating, cleaning, or servicing the cabinet.

**DAILY:**

1. Unplug electrical power supply.
2. Allow warmer to cool before cleaning.
3. Clean the interior of the cabinet with a mild soap and water. *Never use harsh chemicals or abrasive pads to clean the cabinet.*

4. Rinse and dry with a soft dry cloth.
5. Clean the exterior of the cabinet with a clean damp cloth.

**HEAVY-DUTY CLEANING:**

For heavy-duty cleaning, use warm water, a degreaser, and a plastic, stainless steel, or Scotch-Brite pad. Never rub in a circular motion -- rub gently in the direction of the steel grain. Always rinse thoroughly.

**STAINLESS STEEL CARE**

**CLEANING:**

Stainless Steel contains 70 – 80% iron, which will rust if not properly maintained. Stainless Steel also contains 12 – 30% chromium, which forms an invisible passive, protective film that shields against corrosion.

If the protective film remains intact, the stainless steel will remain intact. However, if the film is damaged, the stainless steel can break down and rust.

**PREVENTIVE CARE:**

To prevent stainless steel break-down, follow these steps:

1. Never use any metal tools, scrapers, files, wire brushes, or scouring pads (*except for*

*stainless steel scouring pads,*) which will mar the surface.

2. **Never use steel wool** – which will leave behind particles that will rust.
3. **Never use acid-based or chloride containing cleaning solutions** – which will break down the protective film.
4. **Never rub in a circular motion.** Always rub gently in the direction of the steel grain.
5. **Never leave any food products or salt on the surface.** Many foods are acidic. Salt contains chloride.

**PRESERVING & RESTORING:**

Special stainless steel polishing cleaners can preserve and restore the protective film.

Preserve the life of stainless steel with a regular application of a high-quality stainless steel polishing cleaner, as a final step to daily cleaning.

If signs of breakdown appear, restore the stainless steel surface. First, thoroughly clean, rinse, and dry the surface. Then, on a daily basis, apply a high-quality stainless steel polish according to manufacturer's instructions.

**HEAT TINT:**

Darkened areas, called "heat tint," may appear on stainless steel exposed to excessive heat. Excessive heat causes the protective film to thicken. This is unsightly, but is not a sign of permanent damage.

To remove heat tint, follow the routine cleaning procedure. Stubborn heat tint will require heavy-duty cleaning.

To reduce heat tint, limit the exposure of equipment to excessive heat.

## MAINTENANCE

**⚠ WARNING** The Cabinet and its parts are *HOT*. Be very careful when operating, cleaning, or servicing the cabinet.

**⚠ WARNING** Always unplug electrical power supply before servicing the cabinet.

## LOCKOUT / TAGOUT PROCEDURE

**⚠ WARNING**

Always perform the **LOCKOUT / TAGOUT Procedure** before removing any sheet metal panels or attempting to service this equipment.

The Lockout / Tagout Procedure is used to protect personnel working on an electrical appliance. Before performing any type of maintenance or service on an electrically operated appliance, follow these steps:

1. In electrical box, place unit's circuit breaker into OFF position.
2. Place a lock or other device on electrical box cover to prevent someone from placing circuit breaker ON.
3. Place a tag on electrical box cover to indicate that unit has been disconnected for service and power should not be restored until tag is removed by maintenance personnel.
4. Disconnect unit power cord from electrical outlet.
5. Place a tag on cord to indicate that unit has been disconnected for service and power should not be restored until tag is removed by maintenance personnel.

## TROUBLESHOOTING

SYMPTOMS	POSSIBLE CAUSES	REMEDY
Cabinet not operating	Cabinet not connected to power source.	Connect cabinet to power source.
	No power.	Check circuit breaker
		Check GFCI
Moisture problem.	Dry moisture problem.	
GFCI or Ground Fault Circuit Indicator tripped	Shorted element	Contact Authorized Service Provider.
	Pinched/damaged wire.	Contact Authorized Service Provider.
	Damaged power cord.	Contact Authorized Service Provider.
	Defective: element, thermometer, thermostat, etc.	Contact Authorized Service Provider.
Cabinet is connected to power source, switch is ON, circuit breaker is ON, but cabinet is not heating.	Light faulty	Contact Authorized Service Provider.
Power/Heat Indicator Light not lit.	Door not shut properly or needs adjustment	Check door seal and Contact Authorized Service Provider.
Cabinet does not heat properly	Defective: element, thermometer, thermostat, thermostat requires adjustment	Contact Authorized Service Provider.
Fan not operating	ON/OFF switch not ON	Turn ON/OFF switch on
	Defective fan	Contact Authorized Service Provider.

### SERVICE & PARTS INFORMATION

To obtain Service and Parts information concerning this model, contact Wittco Service Department at the address listed on the front cover of this manual or refer to our website: [www.wittco.com](http://www.wittco.com) for a complete listing of Authorized Service and Parts depots.

<b>Customer Service</b>	<b>414-434-4713</b>
<b>Technical Service</b>	<b>414-434-4716</b>
<b>Service Parts</b>	<b>414-434-4716</b>

**When calling for service, have the model number and serial number available.**

# WIRING DIAGRAMS

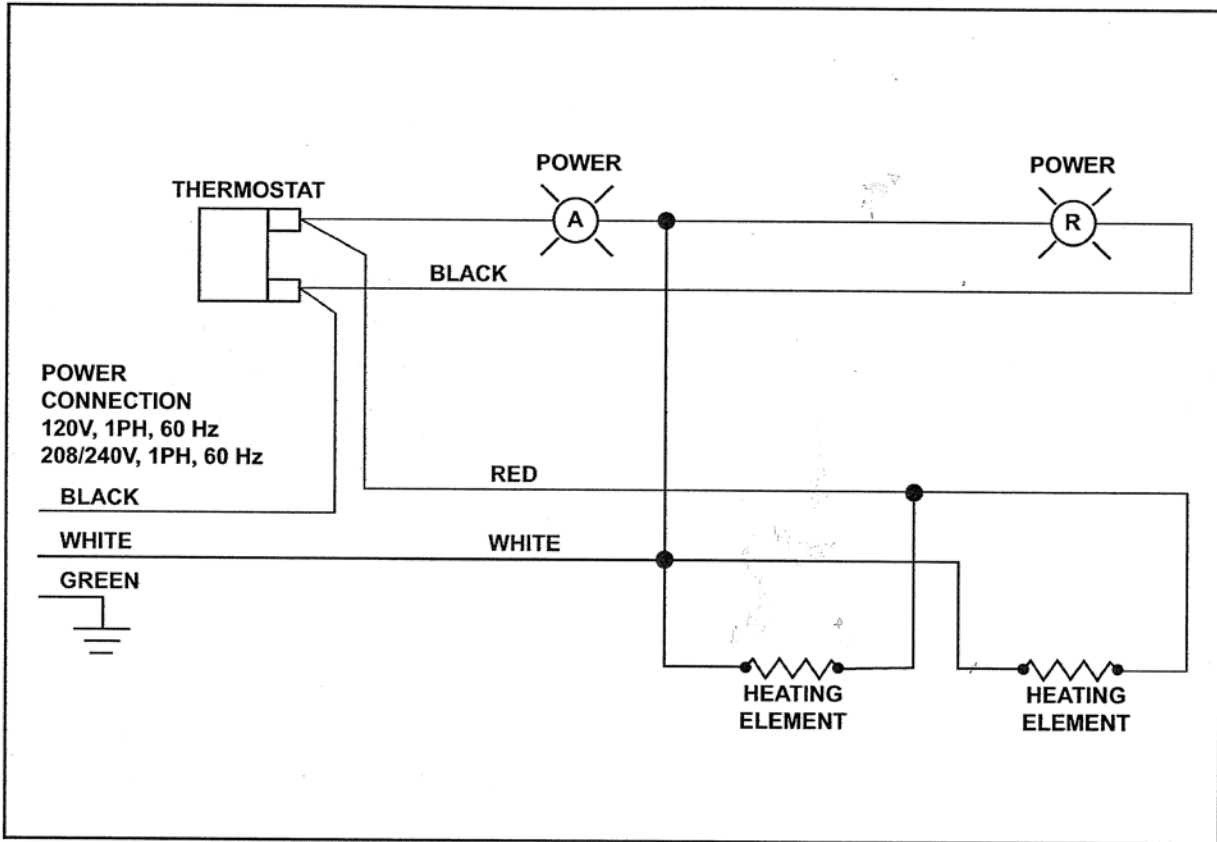

**Models Manufactured before 2010:**

2-90, 2-96, 2-150,  
1826-5-BC-IS, 1826-7-BC-IS, 1826-13-BC-IS, 1826-15-BC-IS,  
1826-7-SCH, 1826-15-SCH,  
1220-15 BC, 1220-20-BC  
580

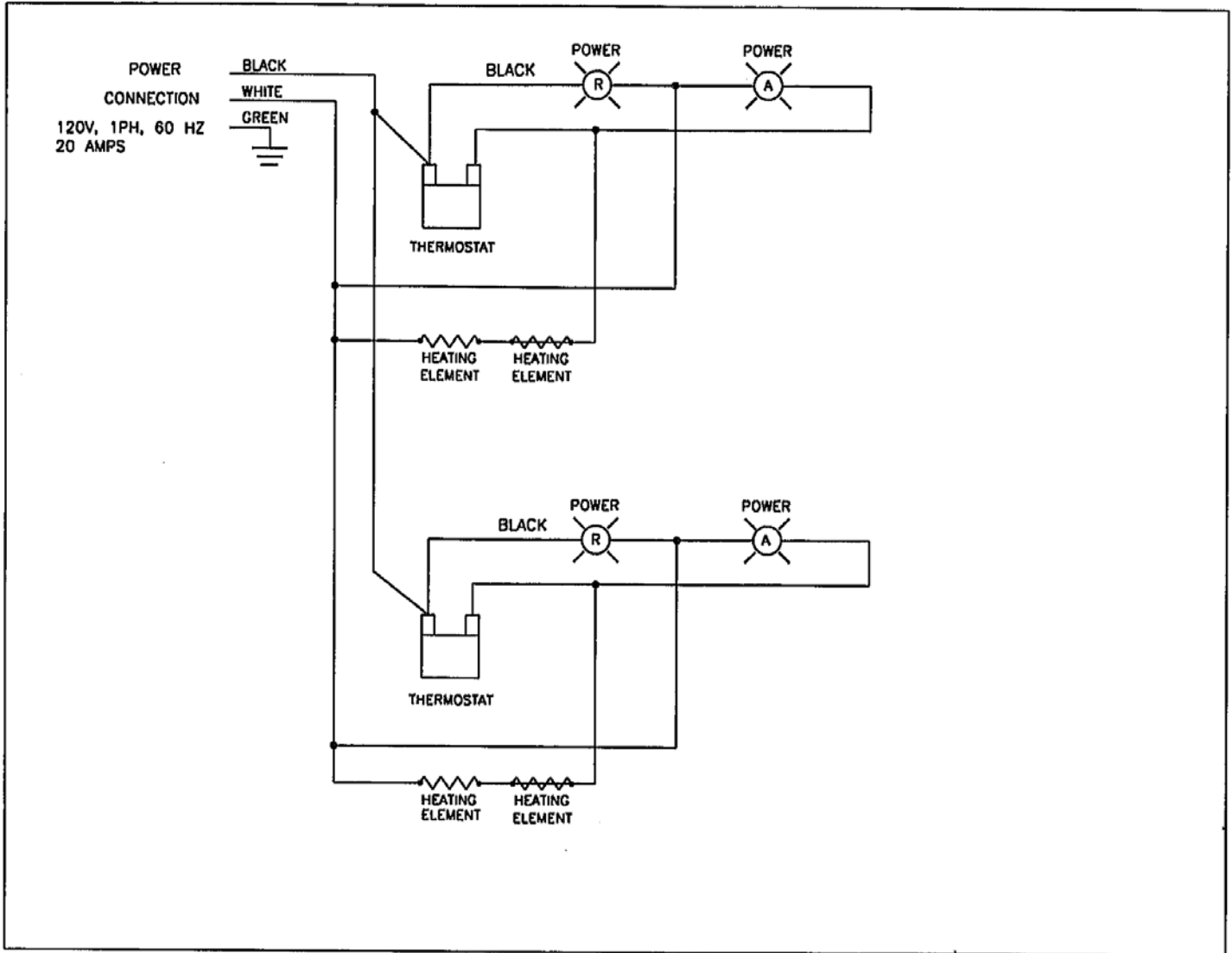

Model Manufactured before 2010

1826-7-DBL-IS

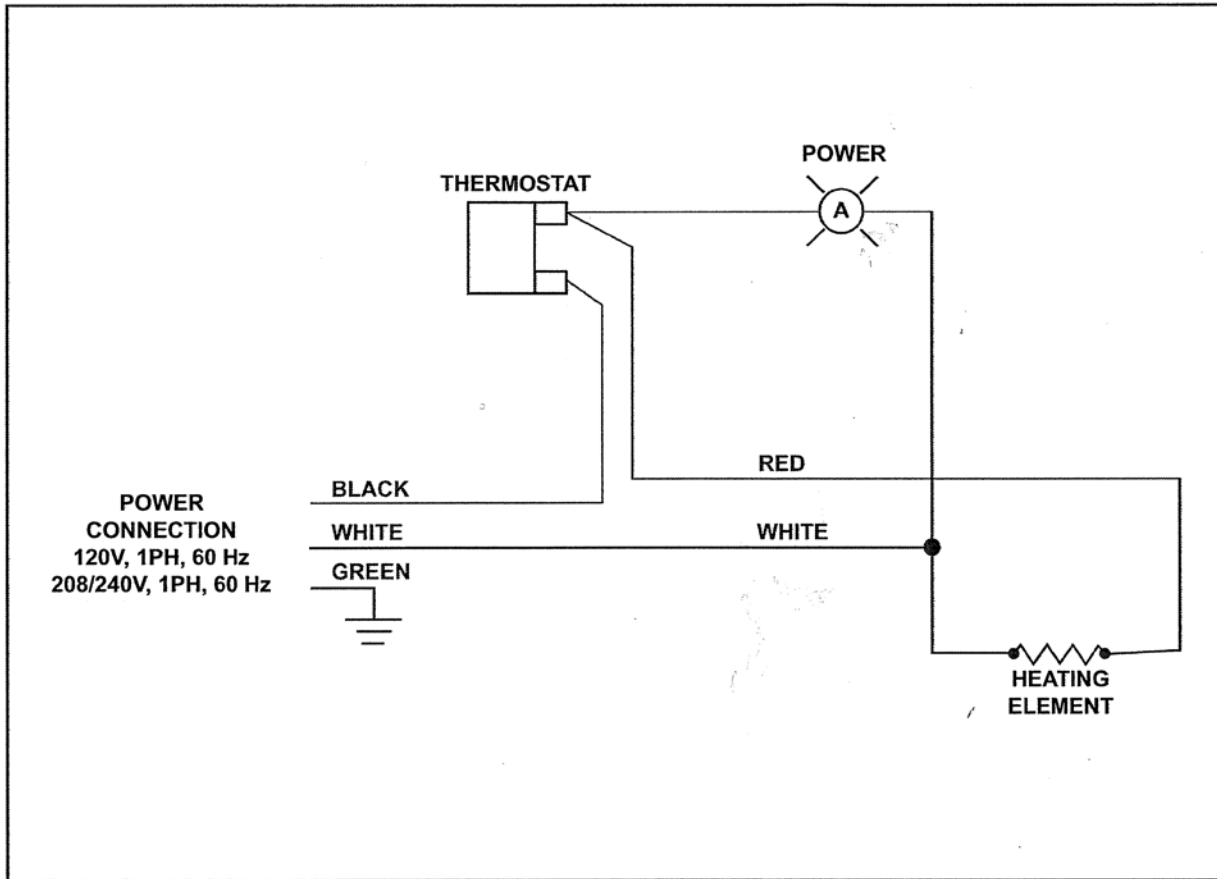

**Models Manufactured before 2010**

**1220-3-BC, 1220-7, 1220-8-BC**

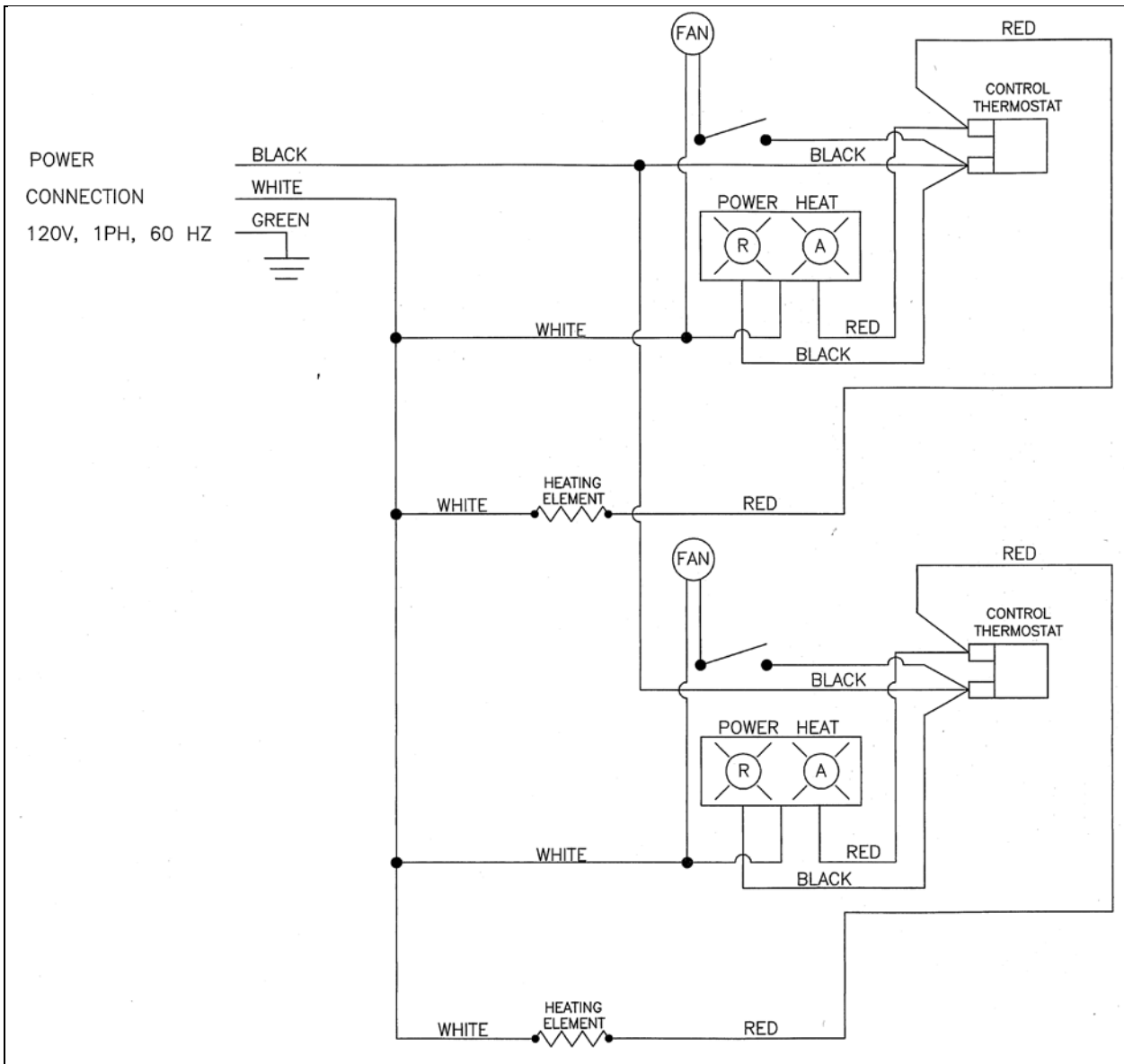

**Model Manufactured 01/01/2010 THROUGH 01/20/2011**

**1826-7-DBL-IS**

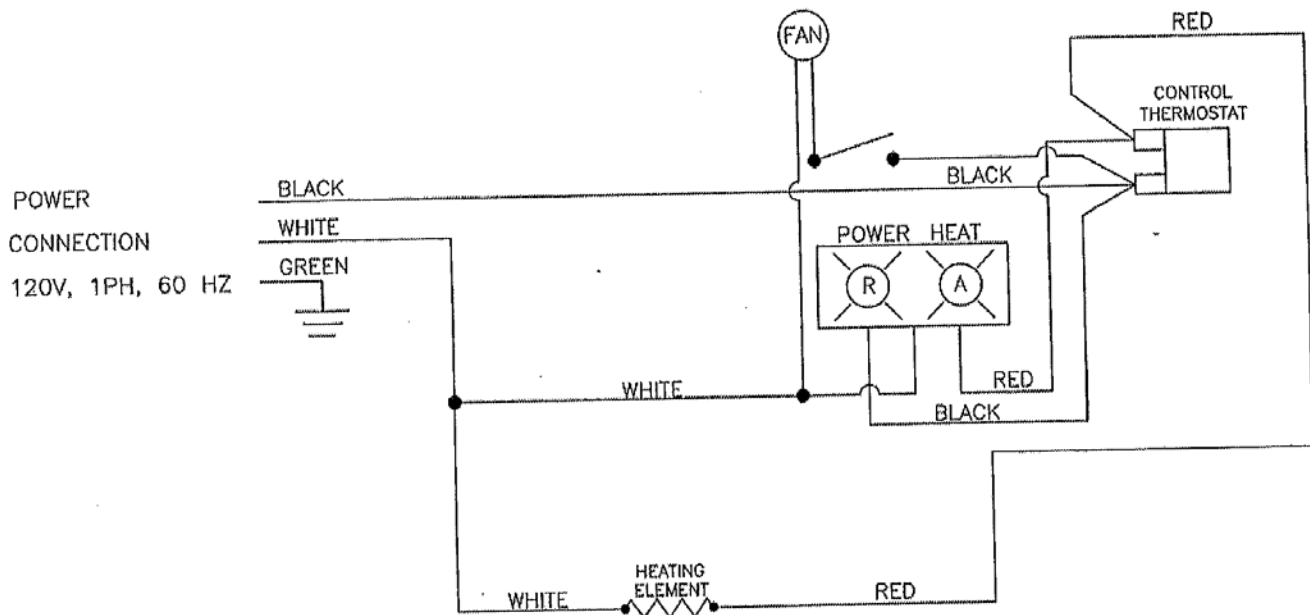

**Models Manufactured after 2010**

1826-5-BC-IS, 1826-7-BC-IS, 1826-13-BC-IS, 1826-15-BC-IS  
1826-7-SCH, 1826-15-SCH  
1220-7-BC, 1220-15-BC

**Model Manufactured after 01/20/2011**

1826-7-DBL-IS



### LIMITED ORIGINAL COMMERCIAL EQUIPMENT WARRANTY

Witco warrants its new product(s) (the "Products") to be free from defects in material and workmanship for a period of one (1) year from the date of original installation.

This warranty is subject to the following conditions and limitations:

1. This warranty is limited to Product(s) sold by Witco to the original user in the continental United States and Canada.
2. Original installation must occur within eighteen (18) months of the date of manufacture, and written proof of the installation date must be provided to Witco. The Products must be located at the original installation location.
3. Witco's sole liability shall be at Witco's option, for Witco to repair or replace any Product(s) found to be defective.
4. Witco will bear normal labor charges incurred in the repair or replacement of a warranted Product within 50 miles (80 kilometers) of an authorized service agency. Time and travel charges in excess of 50 miles (80 kilometers) will be the responsibility of the Buyer requesting the service.
5. This warranty does not apply to any Product(s) which have not been used, maintained or installed in accordance with the directions published in the appropriate installation and operation manuals. Witco will bear no responsibility or liability for any Product(s) which have been mishandled, abused, misapplied, misused, subjected to harsh chemical action or poor water quality, modified by unauthorized personnel, damaged by flood, fire or other acts of nature, or which have altered or missing serial numbers.
6. Witco does not recommend or authorize the use of any Product(s) in a non-commercial application, including but not limited to residential use. The use or installation of Product(s) in non-commercial applications renders all warranties, expressed or implied, including the warranties of MERCHANTABILITY and FITNESS FOR A PARTICULAR PURPOSE, null and void, including any responsibility for damage, costs and legal actions resulting from the use or installation of Product(s) in any non-commercial setting.
7. Adjustments such as calibrations, leveling, tightening of fasteners or utility connections normally associated with original installation are the responsibility of the installer and not that of Witco.
8. Exceptions to the one-year part warranty period are as listed:
  - Rubber seals, light bulbs and gaskets—90 days from installation.
  - Heating elements on drawer warmers cook & hold ovens and holding & transport cabinets have a lifetime warranty.
  - Drawer rollers in drawer and chip warmers have a lifetime warranty.
  - Labor, travel and mileage will be covered during the first year only.
9. Original purchased replacement parts manufactured by Witco will be warranted for 90 days from the parts invoice date. This warranty is for parts cost only, and does not include freight or labor charges.
10. This states the exclusive remedy against Witco relating to the Product(s), whether in contract or in tort or under any other legal theory, and whether arising out of warranties, representations, instructions, installations or defects from any cause. Witco shall not be liable, under any legal theory, for loss of use, revenue or profit, or for substitute use or performance, or for incidental, indirect, punitive or special or consequential damages or for any other loss of cost of similar type. In no event shall Witco's liability exceed the purchase price of the Products.
11. THIS WARRANTY AND THE LIABILITIES SET FORTH HEREIN ARE EXCLUSIVE AND IN LIEU OF ALL OF THEIR LIABILITIES AND WARRANTIES, EXPRESSED OR IMPLIED, INCLUDING BUT NOT LIMITED TO, IMPLIED WARRANTIES OR MERCHANTABILITY AND FITNESS FOR PARTICULAR PURPOSE AND CONSTITUTES THE ONLY WARRANTY OF WITCO WITH RESPECT TO THE PRODUCT(S).