

VULCAN

CATALOG OF REPLACEMENT PARTS

INDUCTION COOKERS

MODELS

<i>ML-114708</i>	<i>VI2 SINGLE 2KW</i>
<i>ML-114709</i>	<i>VI3 SINGLE 3KW</i>
<i>ML-114710</i>	<i>VI22 DOUBLE 2KW</i>
<i>ML-114711</i>	<i>VI33 DOUBLE 3KW</i>
<i>ML-114712</i>	<i>VI23 DOUBLE 2KW/3KW</i>



MODEL VI22

TABLE OF CONTENTS

PAGE	DESCRIPTION
5	SINGLE INDUCTION COOKER
7	DOUBLE INDUCTION COOKER

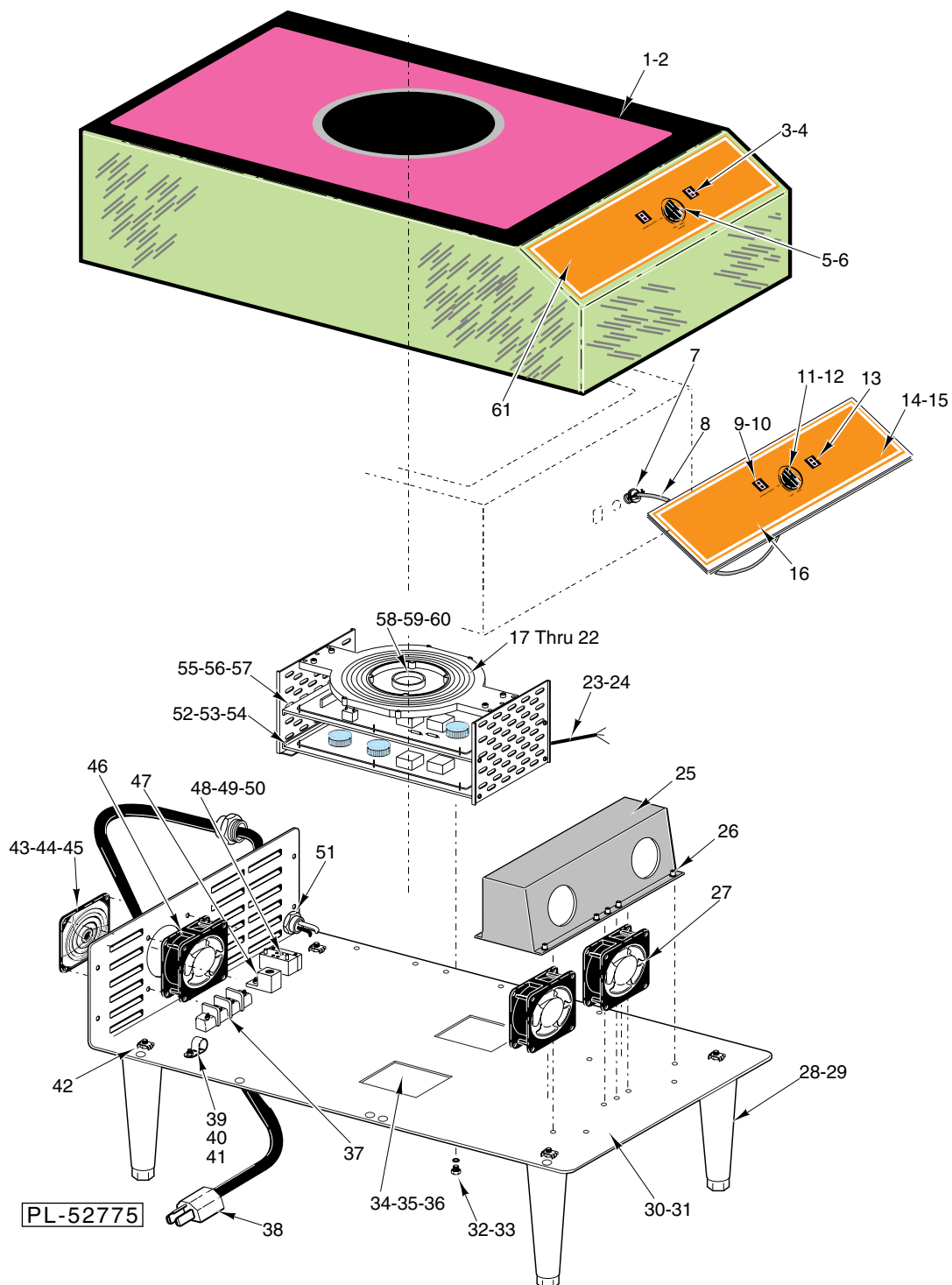

SINGLE INDUCTION COOKER

SINGLE INDUCTION COOKER

ILLUS. PL-52775	PART NO.	NAME OF PART	AMT.
1	00-422993-000G1	Top Induction Assy.	1
2	00-423532-000G1	Top Induction Assy. (Remote)	1
3	00-422842-00004	Controller - Induction (3KW)	1
4	00-422841-00004	Controller - Induction (2.2KW)	1
5	00-423177-00001	Knob	1
6	00-423177-00002	Gasket-Knob	1
7	FE-002-45	Connector - Conduit ½ TS (2 Screws Included)	1
8	00-423270-00001	Cord-Remote Control	1
9	00-422842-00008	Led	1
10	00-423045-00001	Spacer - Plastic 6-32 x ¼	AR
11	00-423177-00001	Knob	1
12	00-423177-00002	Gasket-Knob	1
13	00-422842-00007	Meter - Potentiometer	1
14	00-423124-000G1	Panel - Remote	1
15	00-423125-000G1	Box-Remote Control	1
16	00-422361-00001	Overlay (2KW)(3KW)	1
17	00-422841-000G1	Inverter Assy. (2KW, 220V)	1
18	00-422841-000G2	Inverter Assy. (2KW, 208V)	1
19	00-422842-000G2	Inverter Assy. (3KW, 208V)	1
20	00-422842-00010	Spacer - Plastic (208V. Only)	1
21	00-422841-00007	Transformer (220/240V., 2.2KW)	1
22	00-422841-00008	Transformer (208V., 2.2KW)	1
23	00-422842-00003	Cord - Controller (3KW)	1
24	00-422841-00003	Cord - Controller (2.2KW)	1
25	00-422393-000G1	Housing - Fan	1
26	SD-032-07	Self-Tapping Screw 10-24 x ½ Hex Washer Hd., Type TT	10
27	00-423041-00001	Fan	1
28	00-423042-00001	Leg-Adjustable 1"	4
29	00-423042-00002	Leg-Adjustable 4"	4
30	00-422366-000G1	Plate - Bottom	1
31	00-423424-000G1	Bottom Assy. (Remote)	1
32	SD-032-07	Self-Tapping Screw 10-24 x ½ Hex Washer Hd., Type TT	2
33	WS-028-20	Washer	2
34	00-423036-000G1	Air Filter Assy.	2
35	00-423036-00003	Filter - Media Air	2
36	SC-014-58	Mach. Screw 10-24 x ¾ Slotted Flat Hd.	8
37	00-422842-00009	Terminal Block	1
38	00-423037-00001	Cord-Power	1
39	00-415978-00002	Clamp-Nylon	1
40	SD-032-07	Self-Tapping Screw 10-24 x ½ Hex Washer Hd., Type TT	1
41	NS-044-09	Nut Assy. 10-24 Hex Keps	1
42	00-417853-00002	Nut-Retainer ¼-20	4
43	00-423176-00001	Guard-Fan	1
44	SC-013-40	Mach. Screw 8-32 x 2 Slotted Flat Hd.	4
45	NS-044-07	Nut Assy. 6-32 Hex Keps	4
46	00-423041-00001	Fan	1
47	00-417856-00001	Lug - Grounding (With Set Screw)	1
48	00-340195-00001	Terminal Block (200-240V.)	1
49	SC-121-75	Mach. Screw 8-32 x 1-½ Ful. Thd. Hex Hd.	2
50	NS-044-07	Nut Assy. 6-32 Hex Keps	2
51	00-850192-00001	Connector-Strain Relief	1
52	00-422842-00006	PC Board (3KW)	1
53	00-422842-00013	EMI Board	1
54	00-422841-00006	Board - Low Voltage (2.2KW)	1
55	00-422842-00005	Power Supply (3KW)	1
56	00-422842-00011	Standoff - Plastic	18
57	00-422841-00005	Board - High Voltage (2.2KW)	1
58	00-422842-00012	Thermistor Assy.	1
59	00-422841-00002	Coil (2.2KW)	1
60	00-422842-00002	Coil (3KW)	1
61	00-422361-00001	Overlay (2KW)(3KW)	1

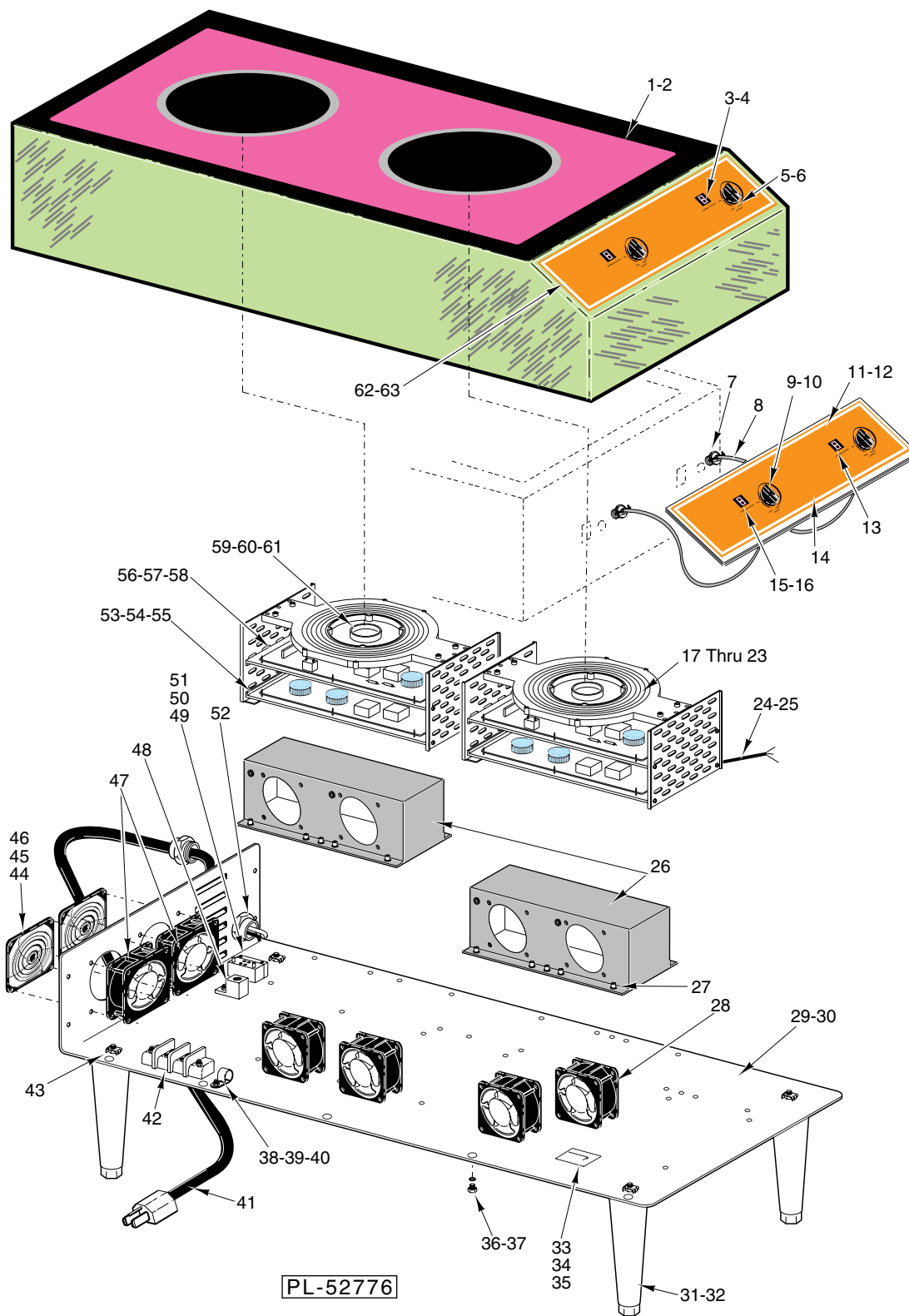

DOUBLE INDUCTION COOKER

DOUBLE INDUCTION COOKER

ILLUS. PL-52776	PART NO.	NAME OF PART	AMT.
1	00-422994-000G1	Top Induction Assy.	1
2	00-423533-000G1	Top Induction Assy. (Remote)	1
3	00-422841-00004	Controller - Induction (2.2KW)	1
4	00-422842-00004	Controller - Induction (3KW)	1
5	00-423177-00001	Knob	2
6	00-423177-00002	Gasket-Knob	2
7	FE-002-45	Connector - Conduit ½ TS (2 Screws Included)	4
8	00-423270-00001	Cord-Remote Control	2
9	00-423177-00001	Knob	2
10	00-423177-00002	Gasket-Knob	2
11	00-423124-000G2	Panel - Remote	2
12	00-423126-000G1	Box - Remote Control	1
13	00-422842-00007	Meter - Potentiometer	1
14	00-422360-00001	Overlay (2KW)(3KW)	1
15	00-423045-00001	Spacer - Plastic 6-32 x ¼	8
16	00-422842-00008	Led	1
17	00-422841-000G1	Inverter Assy. (2KW, 220V)	2
18	00-422842-000G1	Inverter Assy. (3KW, 220V)	2
19	00-422841-000G2	Inverter Assy. (2KW, 208V)	2
20	00-422842-000G2	Inverter Assy. (3KW, 208V)	2
21	00-422842-00010	Spacer - Plastic (208V. Only)	4
22	00-422841-00007	Transformer (220/240V., 2.2KW)	1
23	00-422841-00008	Transformer (208V., 2.2KW)	1
24	00-422841-00003	Cord - Controller (2.2KW)	1
25	00-422842-00003	Cord - Controller (3KW)	1
26	00-422393-000G1	Housing - Fan	2
27	SD-032-07	Self-Tapping Screw 10-24 x ½ Hex Washer Hd., Type TT	20
28	00-423041-00001	Fan	4
29	00-422363-000G1	Plate - Bottom	1
30	00-423422-000G1	Bottom Assy. (Remote)	1
31	00-423042-00001	Leg-Adjustable 1"	4
32	00-423042-00002	Leg-Adjustable 4"	4
33	00-423036-000G1	Air Filter Assy.	4
34	00-423036-00003	Filter - Media Air	4
35	SC-014-58	Mach. Screw 10-24 x ¾ Slotted Flat Hd.	16
36	WS-028-20	Washer	4
37	SD-032-07	Self-Tapping Screw 10-24 x ½ Hex Washer Hd., Type TT	4
38	00-415978-00002	Clamp-Nylon	2
39	SD-032-07	Self-Tapping Screw 10-24 x ½ Hex Washer Hd., Type TT	4
40	NS-044-09	Nut Assy. 10-24 Hex Keps	4
41	00-423038-00001	Cord-Power	1
42	00-422842-00009	Terminal Block	1
43	00-417853-00002	Nut-Retainer ¼-20	4
44	00-423176-00001	Guard-Fan	2
45	SC-013-40	Mach. Screw 8-32 x 2 Slotted Flat Hd.	8
46	NS-044-07	Nut Assy. 6-32 Hex Keps	8
47	00-423041-00001	Fan	2
48	00-417856-00001	Lug - Grounding (With Set Screw)	1
49	00-340195-00001	Terminal Block (200-240V.)	1
50	SC-121-75	Mach. Screw 8-32 x 1-½ Ful. Thd. Hex Hd.	2
51	NS-044-07	Nut Assy. 6-32 Hex Keps	2
52	00-850192-00002	Connector-Strain Relief	1
53	00-422842-00006	PC Board (3KW)	2
54	00-422841-00006	Board - Low Voltage (2.2KW)	2
55	00-422842-00013	EMI Board	2
56	00-422842-00005	Power Supply (3KW)	2
57	00-422841-00005	Board - High Voltage (2.2KW)	2
58	00-422842-00011	Standoff - Plastic	2
59	00-422842-00012	Thermistor Assy.	2
60	00-422841-00002	Coil (2.2KW)	2
61	00-422842-00002	Coil (3KW)	1
62	00-422360-00001	Overlay (2KW)(3KW)	1
63	00-423091-00001	Overlay (2KW)(3KW)	1

