



Outperform every day.™

Installation Instructions

Cheese Melter Wall Mount Brackets

ALL CHEESE MELTERS

NOTICE: Minimum wall mounting surface is 3/4" thick drywall with 16" stud spacing.

NOTICE: Wall material may require specific preparation. Refer to the wall surface manufacturer for instructions regarding proper installation into the material.

NOTICE: This equipment must installed by a qualified installer in accordance with all federal, state and local codes. Failure to install this equipment properly can result in injury or death.

1. Locate the studs.

Cheese Melter	Model	Overall Width	Stud Spacing
CM2-12020	JW1	19 1/4"	16"
CM2-12026	JW2	26 1/4"	32"
CM4-20835 CM4-24035	JW30	38 1/8"	32"
CM4-20835PA CM4-24035PA	JW30PA		

2. Use the included lag bolts to mount and level the brackets.

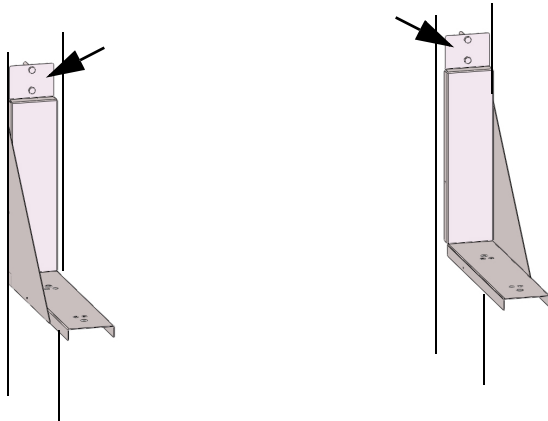

3. Remove the feet from the cheese melter.

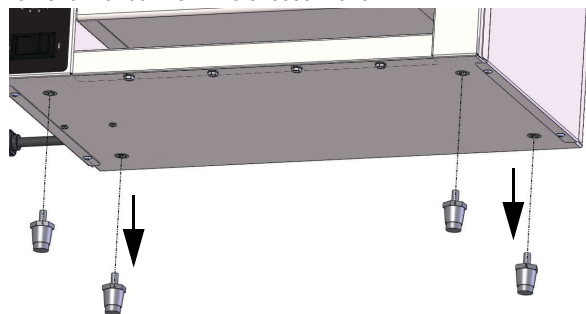

JW1 MODEL CHEESE MELTERS

1. Set the cheese melter onto the brackets. Align the holes on the bottom of the cheese melter with the holes in the brackets.

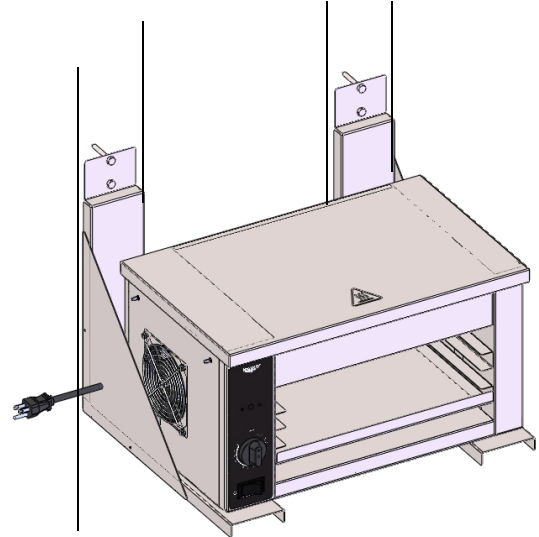

2. Insert and tighten four 1/4" thumb screws.

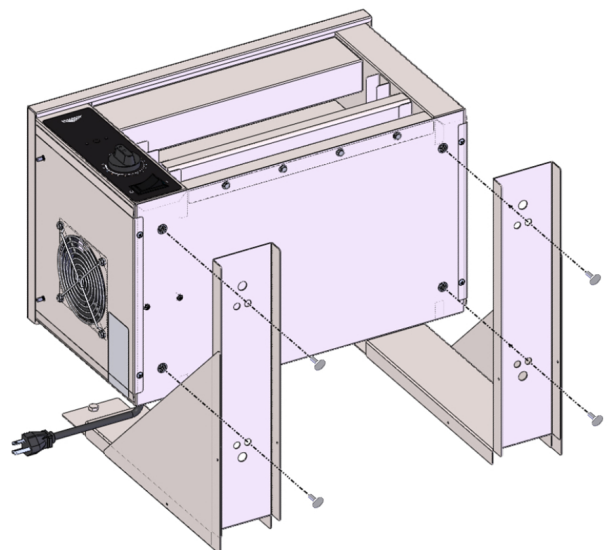

JW2 MODEL CHEESE MELTERS

1. Insert and tighten four $\frac{3}{8}$ " thumb screws and 4 nuts to attach the metal shelf.

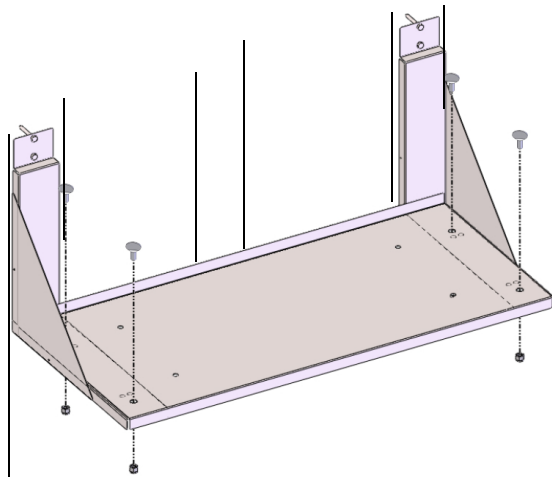

2. Set the cheese melter onto the brackets. Align the holes on the bottom of the cheese melter with the holes in the brackets.

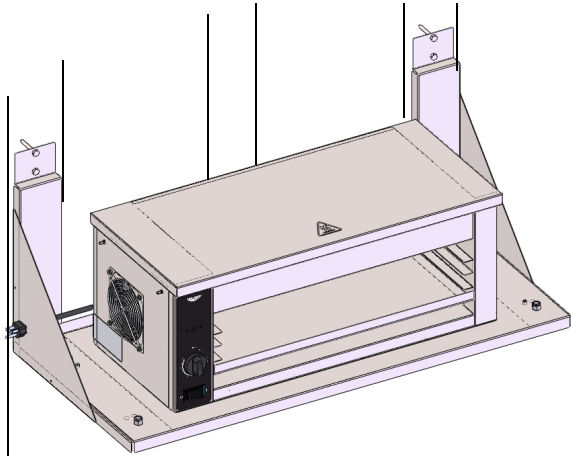

3. Insert and tighten four $\frac{1}{4}$ " thumb screws.

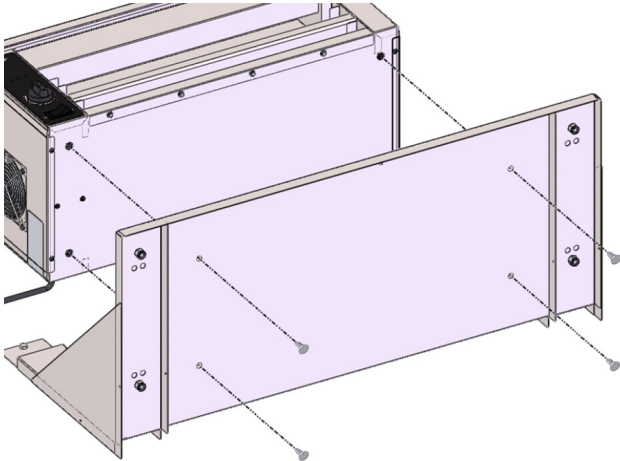

JW30 AND JW30PA MODEL CHEESE MELTERS

1. Set the cheese melter onto the brackets. Align the holes on the bottom of the cheese melter with the holes in the brackets.

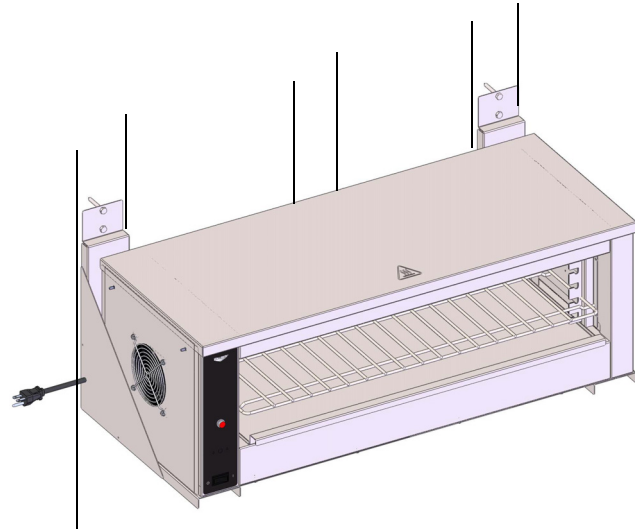

2. Insert and tighten four $\frac{3}{8}$ " thumb screws

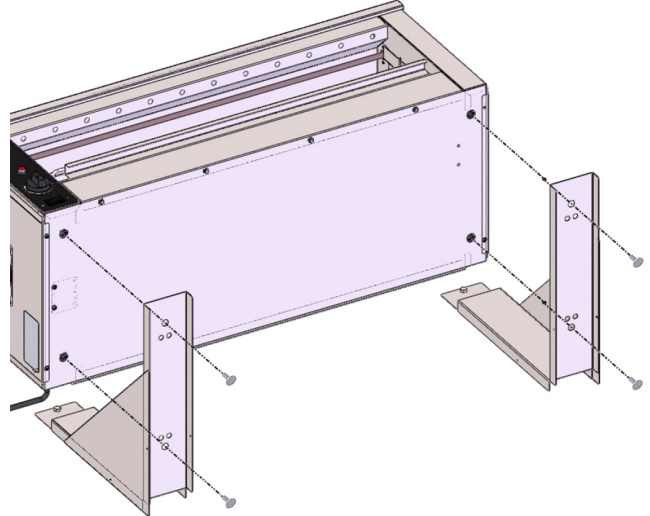

Outperform every day.™

www.vollrath.com

The Vollrath Company, L.L.C.

1236 North 18th Street
Sheboygan, WI 53081-3201 U.S.A.
Main Tel: 800.624.2051 or 920.457.4851
Main Fax: 800.752.5620 or 920.459.6573
Customer Service: 800.628.0830
Canada Customer Service: 800.695.8560

Technical Services

techservicereps@vollrathco.com
Induction Products: 800.825.6036
Countertop Warming Products: 800.354.1970
Toasters: 1-800-309-2250
All Other Products: 800.628.0832

Supports muraux de salamandre

TOUTES LES SALAMANDRES

AVIS : La surface de fixation murale est une cloison sèche de 3/4" (1,9 cm) d'épaisseur minimum pour des poteaux muraux espacés de 16"(40,6 cm).

AVIS : Le matériau du mur exige une préparation spécifique. Pour les instructions d'installation correcte de l'appareil dans le matériau, voir les consignes du fabricant de la surface murale.

AVIS : Cet appareil doit être installé par un installateur qualifié conformément à tous les codes locaux, provinciaux et nationaux. L'installation inadéquate de l'appareil peut causer des blessures, voire la mort.

1. Localisez les poteaux muraux.

Salamandre	Modèle	Largeur totale po / cm	Espacement des poteaux muraux
CM2-12020	JW1	19 1/4" (48,9)	16" (40,6)
CM2-12026	JW2	26 1/4" (66,7)	32" (81,2)
CM4-20835 CM4-24035	JW30	38 1/8" 96,8)	32" (81,2)
CM4-20835PA CM4-24035PA	JW30PA		

2. Utilisez les tire-fonds inclus pour fixer les supports et les mettre de niveau.

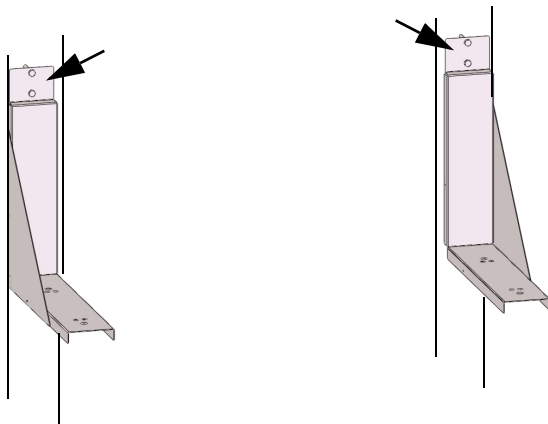

3. Enlevez les pieds de la salamandre.

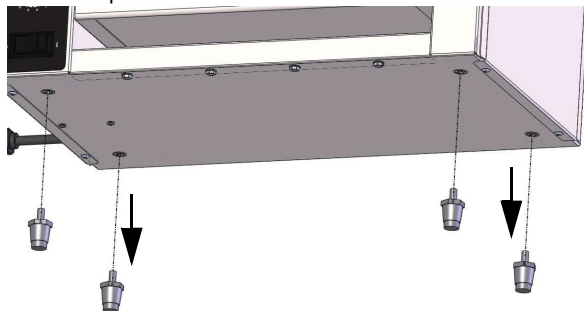

SALAMANDRE MODÈLE JW1

1. Placez la salamandre sur les supports. Alignez les trous en bas de la salamandre sur ceux des supports.

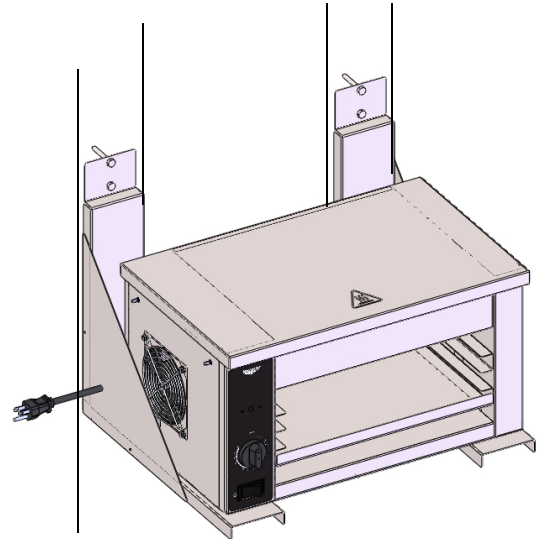

2. Insérez et serrez quatre vis à oreilles 1/4".

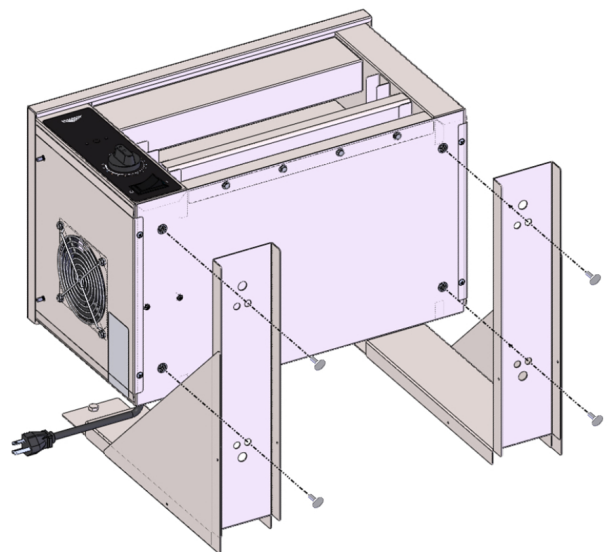

SALAMANDRE MODÈLE JW2

1. Insérez et serrez quatre vis à oreilles $\frac{3}{8}$ " et 4 écrous pour attacher l'étagère métallique.

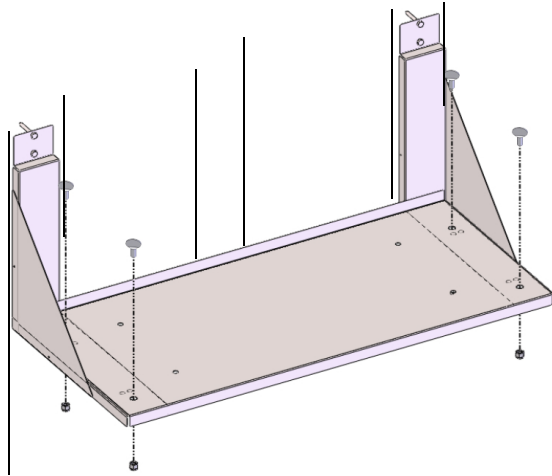

2. Placez la salamandre sur les supports. Alignez les trous en bas de la salamandre sur ceux des supports.

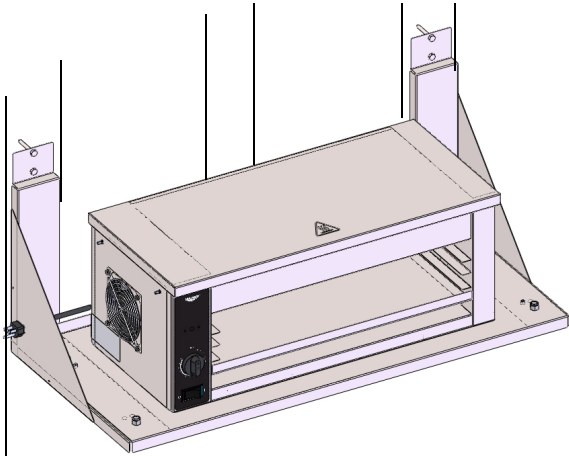

3. Insérez et serrez quatre vis à oreilles $\frac{1}{4}$ ".

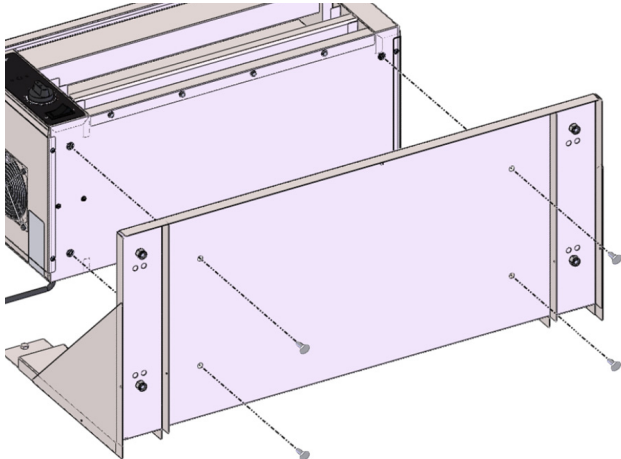

SALAMANDRES MODÈLES JW30 ET JW30PA

1. Placez la salamandre sur les supports. Alignez les trous en bas de la salamandre sur ceux des supports.

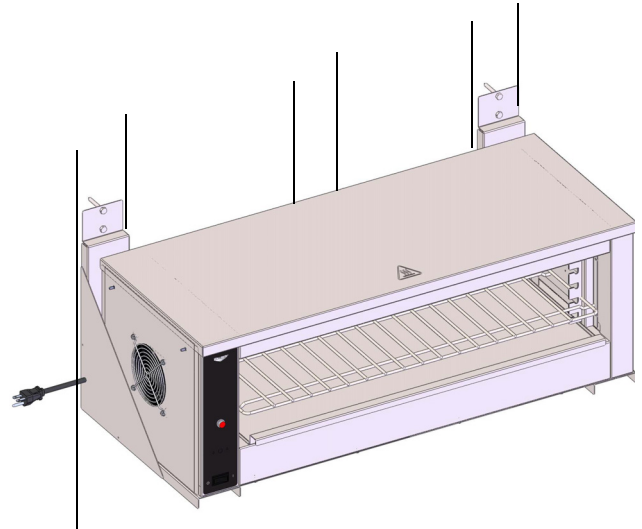

2. Insérez et serrez quatre vis à oreilles $\frac{3}{8}$ ".

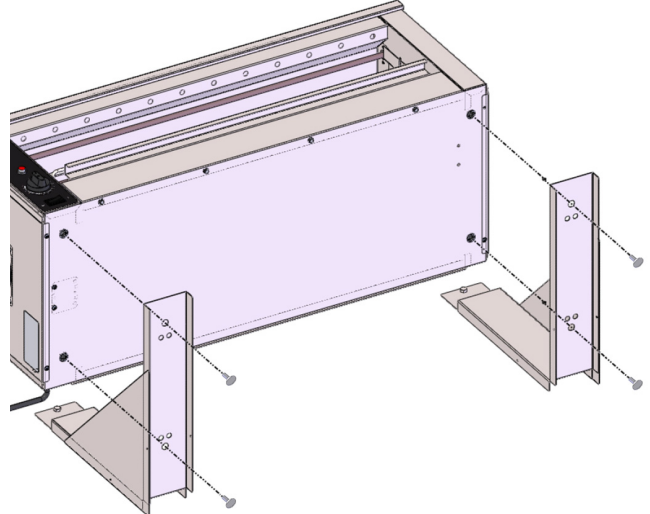

Outperform every day.™

www.vollrath.com

The Vollrath Company, L.L.C.

1236 North 18th Street
Sheboygan, WI 53081-3201 États-Unis
Standard : 800.624.2051 ou 920.457.4851
Télécopieur : 800.752.5620 ou 920.459.6573
Service clientèle : 800.628.0830
Service clientèle Canada : 800.695.8560

Services techniques

techservicereps@vollrathco.com
Produits à induction : 800.825.6036
Réchauds de comptoir : 800.354.1970
Tous les autres produits : 800.628.0832

Instrucciones de instalación

Soportes para el montaje mural de derretidores de queso

TODOS LOS DERRETIDORES DE QUESO

- AVISO:** La superficie mínima para el montaje mural consiste en una pared de yeso con espesor de 3/4" (1,9 cm) y espaciado de 16" (40,6 cm) entre montantes.
- AVISO:** El material de la pared puede requerir una preparación específica. Solicite al fabricante de la superficie de la pared las instrucciones relacionadas con la instalación adecuada del equipo en el material.
- AVISO:** Este equipo debe instalarlo personal calificado de acuerdo con todos los códigos federales, estatales y locales. El no instalar correctamente este equipo puede causar lesiones graves o letales.

1. Ubique los montantes.

Derretidor de queso	Modelo	Ancho general pulg (cm)	Espaciado entre montantes
CM2-12020	JW1	19 1/4" (48,9)	16" (40,6)
CM2-12026	JW2	26 1/4" (66,7)	32" (81,2)
CM4-20835 CM4-24035	JW30	38 1/8" 96,8)	32" (81,2)
CM4-20835PA CM4-24035PA	JW30PA		

2. Use los tirafondos incluidos para montar y nivelar los soportes.

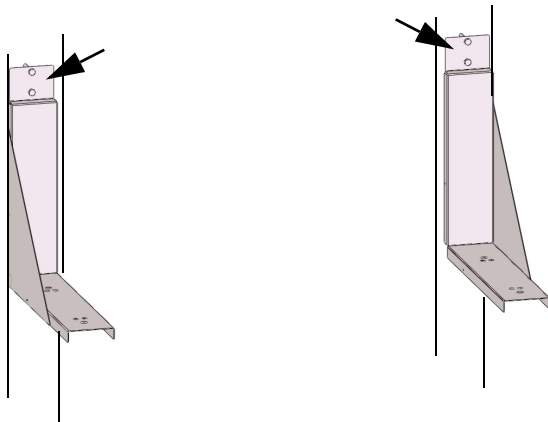

3. Retire las patas del derretidor de queso.

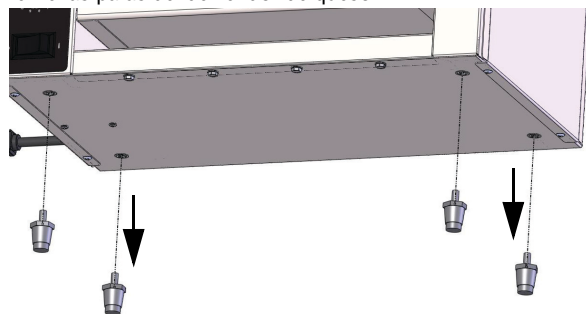

DERRETIDORES DE QUESO MODELO JW1

1. Fije el derretidor de queso en los soportes. Alinee los orificios en la parte inferior del derretidor de queso con los orificios en los soportes.

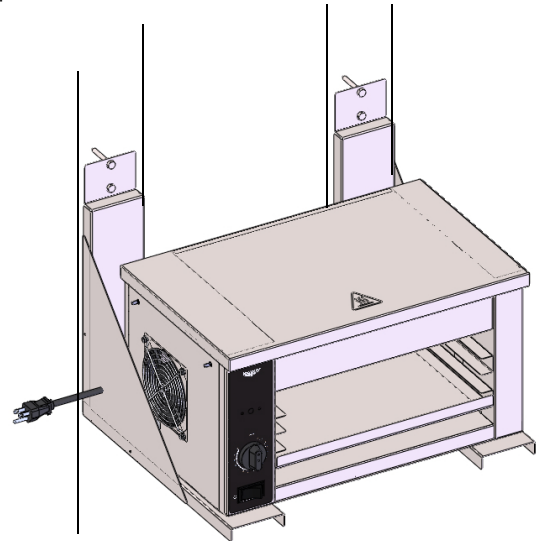

2. Introduzca y apriete cuatro tornillos de mano de 1/4".

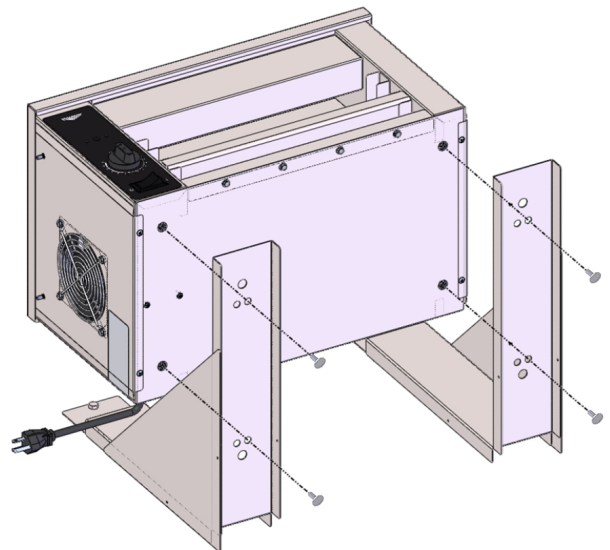

DERRETIDORES DE QUESO MODELO JW2

1. Introduzca y apriete cuatro tornillos de mano de $\frac{3}{8}$ " y 4 tuercas para fijar la repisa metálica.

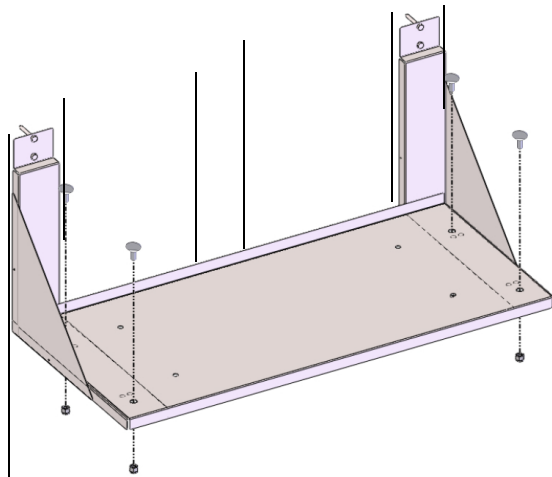

2. Fije el derretidor de queso en los soportes. Alinee los orificios en la parte inferior del derretidor de queso con los orificios en soportes.

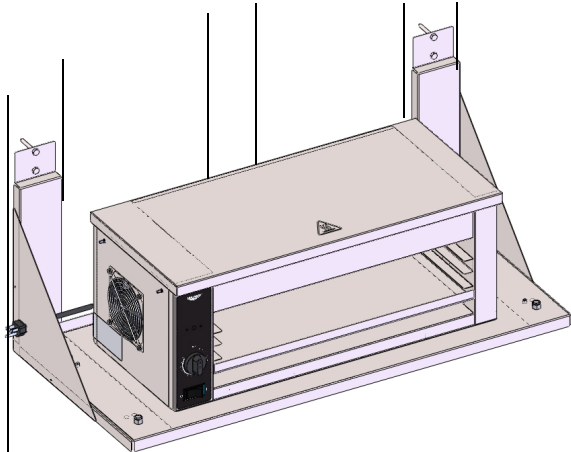

3. Introduzca y apriete cuatro tornillos de mano de $\frac{1}{4}$ ".

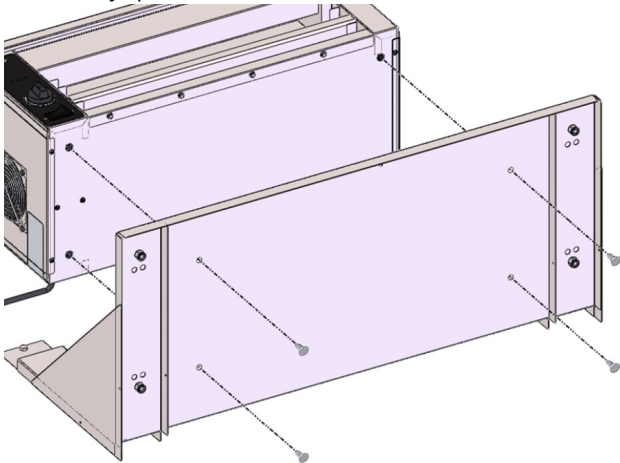

DERRETIDORES DE QUESO MODELOS JW30 Y JW30PA

1. Fije el derretidor de queso en los soportes. Alinee los orificios en la parte inferior del derretidor de queso con los orificios en los soportes.

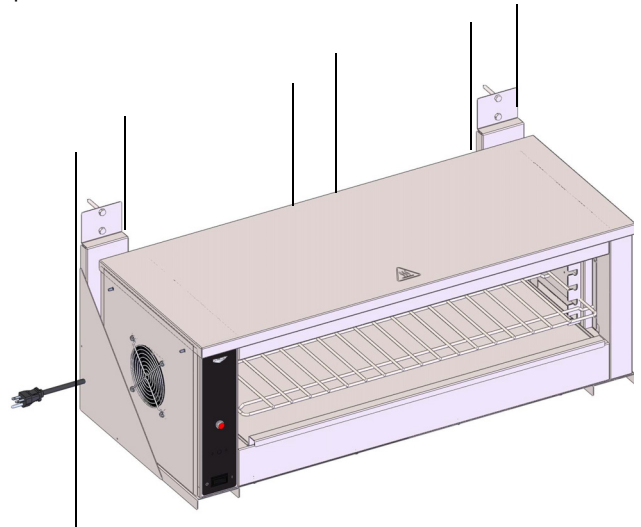

2. Introduzca y apriete cuatro tornillos de mano de $\frac{3}{8}$ ".

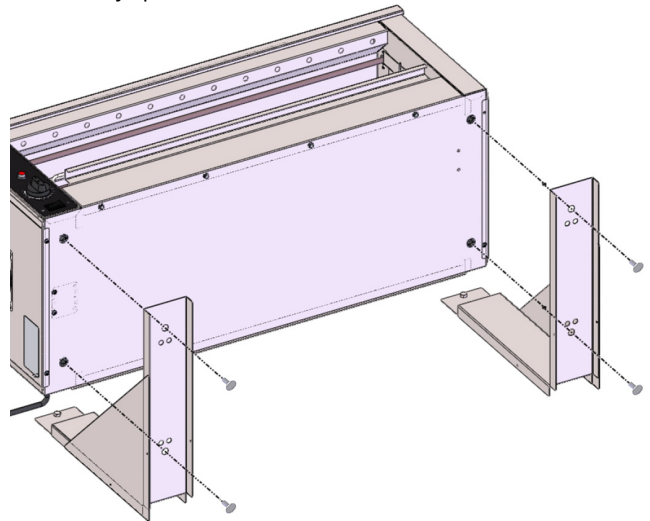

Outperform every day.™

www.vollrath.com

The Vollrath Company, L.L.C.

1236 North 18th Street
Sheboygan, WI 53081-3201 EE. UU.
Tel. principal: 800.624.2051 ó 920.457.4851
Fax principal: 800.752.5620 ó 920.459.6573
Servicio al cliente: 800.628.0830
Servicio al cliente en Canadá: 800.695.8560

Servicios de asistencia técnica:

techservicereps@vollrathco.com

Productos de inducción: 800.825.6036

Productos de calentamiento para mostrador:
800.354.1970

Todos los demás productos: 800.628.0832