

LETTUCE KING™ LETTUCE CUTTER

Thank you for purchasing this Vollrath® product! Save this manual for reference and the packaging in case shipping is necessary.

SAFETY PRECAUTIONS

To help ensure safe use, please read and fully understand this manual and all safety messages before operation!

WARNING

Warning indicates a hazardous situation which, if not avoided, could result in death or serious injury.

CAUTION

Caution indicates a hazardous situation which, if not avoided, could result in minor or moderate injury.

NOTICE: addresses practices not related to physical injury.

To reduce risk of injury or damage to the unit

- Before each use, inspect the unit to ensure it is clean.
- Use unit on a level, smooth, sturdy surface.
- Ensure Pusher Block and Blade Assemblies align and match.
- Ensure blades are sharp and not nicked; replace as necessary.
- **Only use unit if bumpers are in place** and the lowered Pusher Head rests completely on them.
- Lubricate Guide Rods lightly with mineral oil, Petro-Gel, or food-grade lubricant; **cooking oil becomes sticky and could permanently damage the unit.**
- Operate in non-public areas, away from children—and attend the unit during use.
- **Cutting cabbage or hard root vegetables will damage the unit and void the warranty.**
- Only operate if functioning properly and undamaged.

FUNCTION AND PURPOSE

These manual food processors are intended to consistently cut fruit, vegetables, and cooked chicken breasts. **Units are not intended to cut cabbage or hard root vegetables.**

Improved stainless-steel pusher fingers are durable and stay aligned, to give you confidence in a clean cut.



Lettuce King™ I



Lettuce King™ IV with Drum Ring

Item	Description	Replacement Blades Item #	Replacement Pusher Head Assembly
400N	Lettuce King™ I 3/16" (4.8 mm), 37 blades	435	379062
401N	Lettuce King™ I 3/4" (19 mm), 10 blades	434	452
402NC	Lettuce King™ I 3/8" (9.5 mm), 19 blades	484C	482
403N	Lettuce King™ I 1/4" (6.4 mm), 28 blades	485	483
4400N	Lettuce King™ IV 1" X 1" (25.4 X 25.4 mm)	4408	—
2900	Lettuce King™ IV Drum Ring	—	—
Accessory	Description		
4425	Manual Food Processor Blade-Cleaning Brush		

UNPACKING THE UNIT

1. Remove all packing material and tape, as well as any protective plastic; dispose of in an environmentally responsible way when no longer needed.
2. Clean any glue residue left over from the plastic or tape.

LEG INSTALLATION

Lettuce King™ I

1. Place the unit on a flat, stable surface.
2. Use the screws (A) and washers (B) to install legs (C), then tighten with the included Allen wrench (D).

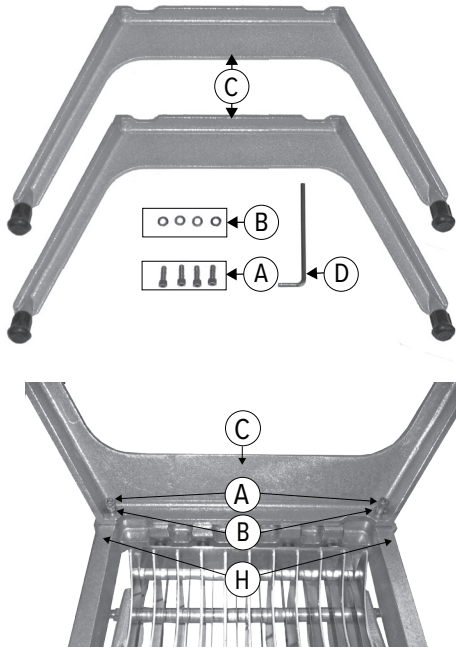

Lettuce King™ IV

1. Place the unit on a flat, stable surface.
2. Set legs (C) into the holes in the base assembly (H) so the angled part of the leg faces outward.
3. Secure legs (C) to base assembly (H) using cap screws (A) and rubber washers (B).
4. Tighten cap screws (A) slowly by rotating legs slightly so screw ends enter notches (E) in the leg (C).

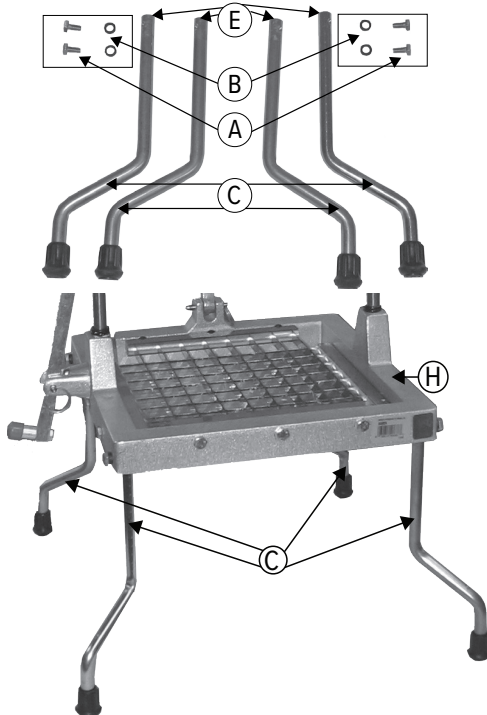

FEATURES AND CONTROLS

- A. GUIDE RODS—align the Pusher Head Assembly onto blades.
- B. HANDLE—Raises and lowers the Pusher Head Assembly.
- C. LEGS—support the equipment.
- D. PUSHER HEAD ASSEMBLY—includes Guides and Pusher Head Block and Handle.
- E. BUMPERS—cushion the stop of the Pusher Head Assembly.
- F. SAFETY LOCK HANDLE & ARM—holds Pusher Head Assembly up.
- G. BLADE ASSEMBLY—houses blades; paired to Pusher Head.
- H. BASE ASSEMBLY—holds Guide Rods and parts of the unit.
- I. LEG SCREWS—secure legs to Base Assembly.
- J. LOCKING PIN—secures Pusher Head Assembly to Base Assembly.

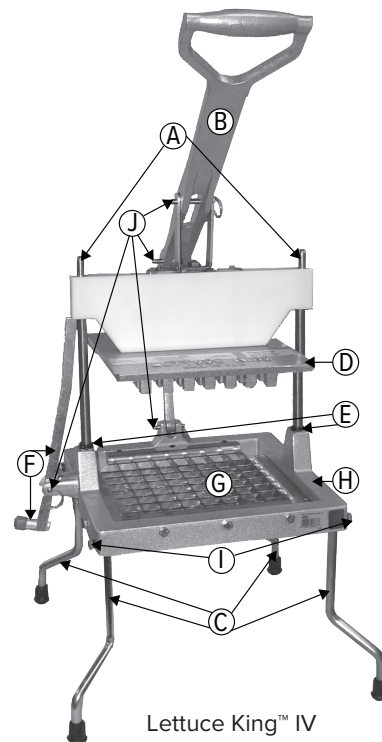
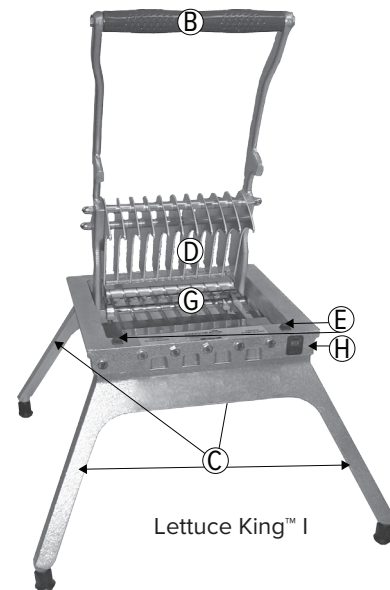

BEFORE FIRST USE



WARNING

Sharp Blade Hazard.

To avoid injury, handle with caution.

1. Keeping sharp edges away from you, carefully wash Blade Assembly in warm, soapy water and rinse thoroughly to remove the thin layer of protective oil.
2. Place the unit on a clean, flat surface.
3. Check blade alignment by slowly lowering Pusher Head Assembly onto Blade Assembly; they should slide smoothly together. If there is resistance, ensure Blade Assembly and Pusher Head Assembly are correctly matched and carefully remove obstructions as necessary.
NOTICE: Do not operate if unit or blades are misaligned or damaged.

TENSIONING BLADES

NOTICE: Blade tension must be checked before first and every use. Failure to inspect and tension Blade Assembly may lead to poor performance and blade damage not covered under warranty.

Tools You Will Need

- Cut-resistant gloves



- 3/8" (10 mm) socket and socket wrench (1/4" drive recommended)
- Torque wrench (optional)



NOTICE: HAND TIGHTEN ONLY; power tools could permanently damage the unit.



NOTICE: It is important to perform the following steps in order. Changing the sequence could damage the unit.

1. Inspect position of the Blade Assembly at the front and left sides of the Base Assembly frame. Blades should be evenly spaced against the inside of the frame. See image of compression spacing in the next column.
2. If the Blade Assembly is not evenly spaced against the frame, use a socket wrench to tighten the screws on the front and left sides as much as possible; corresponding O-rings between the Blade Assembly and the frame should be compressed to approximately 3/32" thick.

2. If you have a torque wrench, use it to verify the screws are tightened to 70 in lbs.

NOTICE: HAND TIGHTEN ONLY; power tools could permanently damage the unit.



OPERATION

NOTICE: Failure to inspect and tension blades before each use could lead to poor performance and blade damage that will void the warranty.

1. Verify unit is clean; check blades and replace and/or tension as needed. Do not use if blades are damaged, misaligned, or not properly tensioned.
2. Check blade alignment by slowly lowering Pusher Head on the Blade Assembly; head and blades should slide together smoothly. If they do not, examine pusher fingers for nicks, burrs, or rough edges and smooth with a small, flat file as needed; be sure to wash/rinse away debris. Also check for uniform space between pusher fingers and straighten the fingers as needed.
3. Prepare food, up to a quarter head of lettuce at once.
4. Lift handle and center food—flat side down—on blades.
5. If using the Lettuce King™ I, move hand from Blade assembly to a leg of the unit. If using the Lettuce King™ IV, hold the Handle, remove hand from Blade Assembly and push the Lock Arm in to release the Pusher Head Assembly.
6. While holding the Handle, use a strong, quick, downward motion to thrust the Pusher Head into the food so the blades cut through entirely.
7. Repeat steps 1–3 until you have enough wedges.
8. Clean and lubricate the unit after each use. Refer to the following CLEANING section for instructions.

CLEANING



WARNING

Sharp Blade Hazard.

To avoid injury, handle with caution.

NOTICE: Clean unit after every use to extend service life, maintain appearance, and avoid blade corrosion from food acids. Hand-wash only; dishwasher detergent and other alkaline chemicals can damage the unit.

1. Raise the handle to the highest position—see Features and Controls section.
2. Use the included brush to clean away larger pieces.
3. Carefully wipe, rinse, or spray unit, Pusher Head Assembly, and Blade Assembly with hot water. Do not wipe across blades or use scrub pads; this could cause injury and will dull the blades.
4. Clean Blade Assembly by spraying water through the unsharpened side; push out food pieces with a nylon brush as needed.
5. Let all parts air dry, then lubricate sliding parts with mineral oil or Petro Gel; **cooking oil becomes sticky and could permanently damage the unit.**

PREVENTATIVE MAINTENANCE

1. Clean unit immediately after every use.
2. Use for intended purposes only; unit is not meant to cut cabbage or hard root vegetables.
3. Change blades when nicked, dull, or damaged.
4. Check blades before each use and tension as necessary; see Tensioning Blades section.

REPLACING BLADE ASSEMBLY



1. Keeping sharp edges away from you, carefully wash Blade Assembly in warm, soapy water and rinse thoroughly to remove the thin layer of protective oil.
2. Refer to your parts diagram and ensure you have ample space to work on a flat, dry surface.
3. Raise the Handle and Pusher Head as far as they will go.
4. Remove Blade Assembly screws; carefully dispose of the old blade assembly.
5. Check for nicks, burrs, and rough edges on Pusher Head fingers; smooth with a small, flat file as needed. Straighten bent fingers to ensure spacing is equal.
6. Ensure Blade Shields are installed on Blade Assembly.

Lettuce King™ I

7. Verify Pusher Head Bumpers are installed; clean the surface and install new bumpers as needed.
8. Place Blade Assembly into Base Assembly so it is flush with the sharp side up.
9. Tighten screws into Base Assembly back until they make contact and are tight, not to exceed ½ turn or 40 in. lbs.
10. Place rubber washer between Base Assembly and Lower Blade Assembly. Insert screws through the frame and rubber washer into Blade Assembly and tighten, not to exceed ½ turn or 40 in. lbs.
11. Slowly lower Pusher Head onto Blade Assembly. If there is contact, check alignment and adjust by loosening the Locking Collar Set Screws and repositioning the Pusher Head fingers, then retightening the set screws.
12. Lubricate Pusher Head Pivot Rod with mineral oil or Petro Gel; **cooking oil gets sticky and could damage the unit.**

Lettuce King™ IV

7. Place the Lower Blade Assembly into the frame so it is flush with the sharp side up; tighten screws into left side of Base Assembly until contact is made and screws are tight, not to exceed ½ turn or 40 in. lbs.
8. Place rubber washer between the right side of the frame and the Lower Blade Assembly; insert screws through the frame and washer into the Blade Assembly and tighten, not to exceed ½ turn or 40 in. lbs.
9. Place Upper Blade Assembly into the frame so it is flush with the sharp side up; tighten screws into front of Blade Assembly until contact is made with the frame, not to exceed ½ turn or 40 in. lbs.
10. Place rubber washer between the back side of the frame and the Lower Blade Assembly; insert screws through the frame and washer into the Blade Assembly; tighten, not to exceed ½ turn or 40 in. lbs.
11. Slowly bring the Pusher Head down to the blades.
12. Lubricate Guide Rods with mineral oil or Petro Gel; **cooking oil gets sticky and could damage the unit.**

TROUBLESHOOTING

Problem	Potential Cause	Course of Action
Blade(s) broke.	Blades are dull.	Replace Blade Assembly and Pusher Block if damaged.
Pusher Head does not slide easily.	Pivot/Guide Rod(s) is/are not properly lubricated.	Clean & lubricate rods.
Food is damaged.	Blades are damaged/dull.	Replace Blade Assembly.
Food cannot be pushed through.	Blade Assembly & Pusher Head do not match.	Confirm Block & Blade Assembly are same size & cut and they glide smoothly. If not, install matching set.
	Blades are misaligned	If Block is correct, tension blades per that section.

SERVICE AND REPAIR

Serviceable parts are available on vollrathfoodservice.com.

To avoid serious injury or damage, never attempt to repair the unit or replace a damaged power cord yourself. Do not send units directly to The Vollrath Company LLC. Please contact Vollrath Technical Services for instructions.

When contacting Vollrath Technical Services, please be ready with item number, model number (if applicable), serial number, and proof of purchase showing the date the unit was purchased.

WARRANTY STATEMENT FOR THE VOLLRATH CO. L.L.C.

This warranty does not apply to products purchased for personal, family or household use, and The Vollrath Company LLC does not offer a written warranty to purchasers for such uses.

The Vollrath Company LLC warrants the products it manufactures or distributes against defects in materials and workmanship as specifically described in our full warranty statement. In all cases, the warranty runs from the date of the end user's original purchase date found on the receipt. Any damages from improper use, abuse, modification, or damage resulting from improper packaging during return shipment for warranty repair will not be covered under warranty.

For complete warranty information, product registration, and new product announcements, visit vollrathfoodservice.com.

United States
The Vollrath Company, L.L.C. Headquarters
1236 North 18th Street
Sheboygan, Wisconsin 53081-3201 USA
Main Tel: 800-319-9549 or 920-457-4851
Main Fax: 800-752-5620 or 920-459-6573
Canada Customer Service: 800-695-8560
Tech Services: techservices@vollrathco.com
vollrathfoodservice.com

Spain
Vollrath Pujadas Sau.
Ctra De Castanyet, 132
PO Box 121
17430 Santa Coloma De Farners
Girona
Spain
Tel: +34972843201
info@pujadas.es

China
Vollrath (Shanghai) Trading Limited
Rm 906, Building A
Hongwell Plaza
1308 Lianhua Road
Minhang District
Shanghai, 201102
Tel. 86-21-50589580
info@pujadas.es

Mexico
Vollrath de Mexico S. de R.L.
de C.V. Periferico Sur No.
7980 Edificio 2-C Col. Santa
Maria Tequepexpan 45601
Tlaquepaque, Jalisco | Mexico
Tel: +52-33-3133-6767
Tel: +52-33-3133-6769
Fax: +52-33-3133-6768