

Operator's Manual

COUNTERTOP SANDWICH PRESS



Item	Description	Voltage	HZ	Watts	Plug
40789	Sandwich Press, Ribbed Plate	120V	50/60	1800 (15 Amps)	5-15P
40790	Sandwich Press, Ribbed Plate, Coated	120V	50/60	1800 (15 Amps)	5-15P
40791	Sandwich Press, Flat Plate	120V	50/60	1800 (15 Amps)	5-15P
40792	Sandwich Press, Flat Plate, Coated	120V	50/60	1800 (15 Amps)	5-15P
40793	Sandwich Press, Flat Plate, Large	120V	50/60	1800 (15 Amps)	5-15P

Thank you for purchasing this Vollrath Counter Top Cooking Equipment. Before operating the unit, read and familiarize yourself with the following operating and safety instructions. **SAVE THE ORIGINAL BOX AND PACKAGING.** Use this packaging to ship the unit if repairs are needed. **SAVE THESE INSTRUCTIONS FOR FUTURE REFERENCE.**

SAFETY PRECAUTIONS

To ensure safe operation, read the following statements and understand their meaning. This manual contains safety precautions which are explained below. Please read carefully.

WARNING

Warning is used to indicate the presence of a hazard that *can* cause *severe* personal injury, death, or substantial property damage if the warning is ignored.

CAUTION

Caution is used to indicate the presence of a hazard that *will* or *can* cause *minor* personal injury or property damage if the caution is ignored.

NOTE

Note is used to notify people of installation, operation, or maintenance information that is important but not hazard-related.

For Your Safety!

These precautions should be followed at all times. Failure to follow these precautions could result in injury to yourself and others.

To reduce risk of injury or damage to the unit:

- Use only grounded electrical outlets matching the nameplate rated voltage.
- Have equipment installed by a qualified personal in accordance with local codes and ordinances.
- This unit must only be used in a flat, level position.
- Do not use an extension cord with this unit.
- Unplug the unit, turn off and let it cool before cleaning or moving.
- Do not spray controls or outside of the unit with liquids or cleaning agents.
- Do not clean the unit with steel wool.
- Keep the unit and power cord away from open flames, electric burners or excessive heat.
- Do not operate the unit unattended.
- Do not operate the unit in public areas and/or around children.
- The unit may be hot, even though the pilot light is not on.
- Do not operate if the unit has been damaged or is malfunctioning in any way.

FUNCTION AND PURPOSE

This unit is intended to be used for contact grilling foods in commercial foodservice operations only. It is not intended for household, industrial or laboratory use.

Before using this equipment it must be cleaned and dried thoroughly. Clean all surfaces before use. Failure to clean surfaces before using the unit could cause food contamination.

This sandwich press is a medium duty appliance capable of a wide variety of applications. The temperature is thermostatically controlled. The temperature range for non-coated surface models is between 120°F (49°C) and 550°F (288°C). The temperature range for coated surface models is between 120°F (49°C) and 470°F (243°C) The thermostat is also the ON/OFF switch. An indicator lamp adjacent to the thermostat dial indicates when the elements are heating.

UNPACKING THE EQUIPMENT AND INITIAL SETUP

Dispose of all packaging, materials in an environmentally responsible manner.

1. Remove all packing material and tape, as well as any protective plastic from the unit.
2. Clean any glue residue left over from the plastic or tape.
3. Place the unit in the desired position and height.
4. Plug the unit into a properly grounded electrical supply matching the nameplate rating. Damage to the unit can occur if incorrect power is supplied.

FEATURES AND CONTROLS

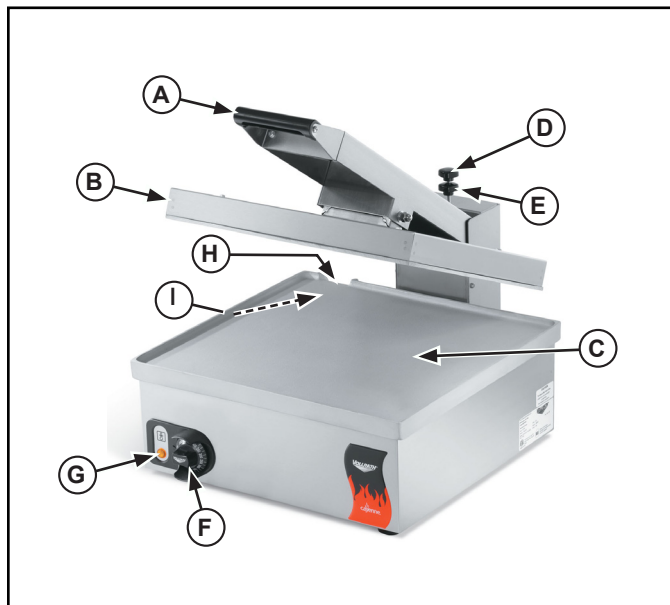

Figure 1. Features and Controls

- (A) HANDLE.** Used to control the up and down movement of the top grill plate.
- (B) TOP GRILL PLATE.** Contains a heating element and heats food.
- (C) BOTTOM GRILL PLATE.** Contains a heating element and heats food.



- D HEIGHT ADJUSTMENT.** This is an adjustable rod that limits or restricts the downward stop position of the top grill plate.
- E LOCK NUT.** Used to lock the position of the height adjustment.
- F THERMOSTAT CONTROL dial.** Used to set or adjust the temperature of the grill plates. The numbers on the dial correspond with the grill plate temperature. The “0” position is off.
- G PILOT LIGHT.** This light indicates that the element is heating. Once the set temperature has been reached the light will go out. Unit will continue to maintain heat and temperature with the light cycling on and off. This is not a power indicator light.
- H DRIP TROUGH.** Opening located on the bottom grill plate for grease or oil to drain out.
- I DRIP CUP.** A container under the grease trough that collects grease, oil and liquid from the grease trough.

- 3. At the end of each cooking cycle wipe down the cooking plates. Never allow excess fat, oil, or grease to build up as this will result in a build-up of carbon on the plates.
- 4. Ensure the drip cup provided is in place on the back of the unit during operation. Empty the grease cup periodically to ensure it does not overflow.

CLEANING

To maintain the appearance and increase the service life, clean your unit daily.

	WARNING
	Burn Hazard. Do not touch hot food, liquid or heating surfaces while unit is heating or operating.
Hot surfaces and food can burn skin. Allow the hot surfaces to cool before handling. Do not drop or spill water into the cooking surface as it can spray or splatter.	

NOTE:
Do not clean the unit with steel wool.

- 1. Allow the unit to cool completely before cleaning.

OPERATION

	WARNING
	Burn Hazard. Do not touch hot food, liquid or heating surfaces while unit is heating or operating.
Hot surfaces and food can burn skin. Allow the hot surfaces to cool before handling. Do not drop or spill water into the cooking surface as it can spray or splatter.	

Before initial use, turn the thermostat control to the maximum setting, close the lid and allow unit to burn in for 30 minutes. You may notice smoke appearing due to the cooking surface burning in. This is normal. After 30 minute burn in period the unit is ready for use.

To adjust the self leveling grill plates:

- 1. Center the food product on the bottom grill plate (C) and lower the top grill plate (B). See Figure 1.
- 2. Adjust the height adjustment (D) until the desired level is reached. Turn the lock nut (E) to set the position of the height adjustment (D).

To begin heating or cooking:

- 1. Preheat unit to desired temperature.
- 2. Use handle (A) to lower top grill plate (B) to desired height. Heat or cook for desired length of time.

	WARNING
	Electrical Shock Hazard. Keep water and other liquids from entering the inside of the unit. Liquid inside the unit could cause an electrical shock.
Do not spray water or cleaning products. Liquid could contact the electrical components and cause a short circuit or an electrical shock. Do not use unit if power cord is damaged or has been modified	

- 2. Unplug the unit.
- 3. Do not immerse the cord, plug or unit in water or any other liquid.
- 4. Wipe grease or oil to the drip trough (H) and into the drip cup (I). See Figure 1.
- 5. Using a damp cloth or sponge dipped in soapy water, clean the unit and plates; rinse thoroughly.
- 6. Dry thoroughly after cleaning.
- 7. Empty and clean the drip cup (I).

	WARNING
	Electrical Shock Hazard. Keep water and other liquids from entering the inside of the unit. Liquid inside the unit could cause an electrical shock.
Do not spray water or cleaning products. Liquid could contact the electrical components and cause a short circuit or an electrical shock. Do not use unit if power cord is damaged or has been modified	

ENGLISH

TROUBLESHOOTING

TROUBLESHOOTING CHART

Problem	It might be caused by	Course of Action
Pilot Light does not come on when the temperature control is turned up.	Unit is not plugged in.	Plug unit in.
	Pilot Light malfunction.	Replace Pilot Light.
Grill Plates do not get hot.	Low or no voltage from power source (wall outlet).	Verify correct voltage is being provided to unit. If not, have qualified personnel correct power problem.
	Heating Element is faulty.	Replace Heating Element.

SERVICE AND REPAIR

There are no user serviceable parts within this appliance. To avoid serious injury or damage, never attempt to repair the unit or replace a damaged power cord yourself. Do not send units directly to the Vollrath Company. Please contact the qualified professional repair service listed below.

VOLLRATH Technical Services • 1-800-628-0832



ELECTRICAL DRAWING - COUNTERTOP SANDWICH PRESS, MODEL ~ 40789, 40790, 40791, 40792, 40793

120V ~ 1800Watt

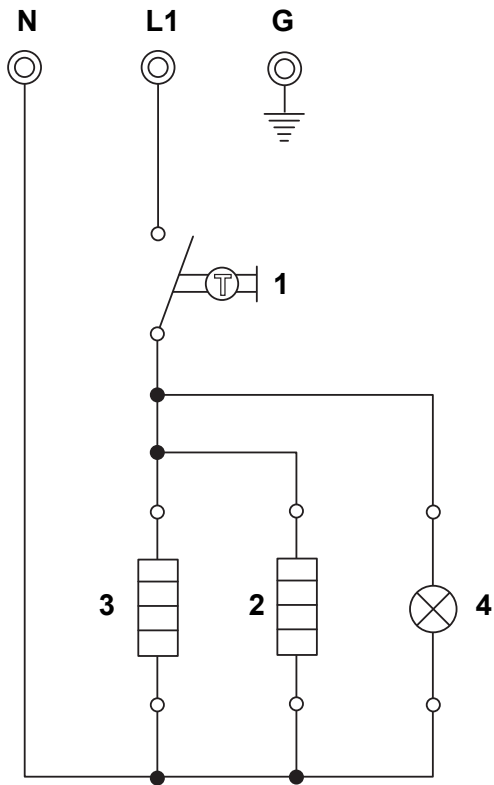

Callout	Part Number	Description
1	XTSA0007	Thermostat Control
2		Heating Element, Top, 120V ~ 800 Watt
3		Heating Element, Bottom, 120V ~ 1000 Watt
4	XAA0011	Pilot Light, 120V, Amber

ENGLISH

SPARE PARTS LIST - COUNTERTOP SANDWICH PRESS, MODELS ~ 40789, 40790, 40791, 40792

Callout	Part Number	Description
1	XTSA0013	Handle Pivot Hardware
2	N/A	Top Arm
3	XTSA0050	Handle Bracket
4	XTSA0003	Plastic Handle Grip
5	N/A	Top Cover
6	XTSA0052	Spacer, Hex
7	N/A	Element Retainer Clamp
8	XTSA0026	Fiber Heat Shield (5MM)
9	XTSA0012	Top Heating Element, 120V ~ 800 Watt
10	XTSA0028	Top Plate, Ribbed, Non-Coated (Model 40789)
10	XTSA0035	Top Plate, Ribbed, Coated (Model 40790)
10	XTSA0009	Top Plate, Flat, Non-Coated (Model 40791)
10	XTSA0033	Top Plate, Flat, Coated (Model 40792)
11	XTSA0011	Bottom Heating Element 120V ~ 1000 Watt
12	XAA0011	Pilot Light, 120V, Amber
13	N/A	Light Facia
14	XTSA0015	Thermostat Control Knob, Non-Coated Models 40789 and 40791
14	XTSA0014	Thermostat Control Knob, Coated Models 40790 and 40792
15	XAA0009	Control Panel Facia
16	N/A	Vollrath Logo Decal
17	XTSA0007	Thermostat, Non-Coated Models 40789 and 40791
17	XTSA0023	Thermostat, Coated Models 40790 and 40792
18	N/A	Press Body
19	XTSA0006	Eye Bolt, Plated
20	XTSA0004	Foot, Rubber
21	N/A	Cover, Bottom, Vented
22	XTSA0025	Cover, Bottom
23	N/A	Insulation Pad
24	XTSA0043	Handle Assembly, Complete (Includes Ref. No. 1, 2, 3, 4, [qty. 2 of 34])
25	XCOA1013	Power Cord Restraint
26	XAA0005	Power Cord, 120V, NEMA 5-15P Plug
27	XTSA0032	Height adjustment Screw and Knob Assembly (6MM)
28	N/A	Handle Base
29	XTSA0027	Bottom Plate, Ribbed, Non-Coated (Model 40789)
29	XTSA0036	Bottom Plate, Ribbed, Coated (Model 40790)
29	XTSA0008	Bottom Plate, Flat, Non-Coated (Model 40791)
29	XTSA0034	Bottom Plate, Flat, Coated (Model 40792)
30	XTSA0001	Handle Spring
31	XTSA0002	Drip Cup
32	XTSA0057	Spring Support Bracket
33	XTSA0005	Connector Block
34	XTSA0051	Screw, for Handle



EXPLODED VIEW - COUNTERTOP SANDWICH PRESS, MODELS ~ 40789, 40790, 40791, 40792

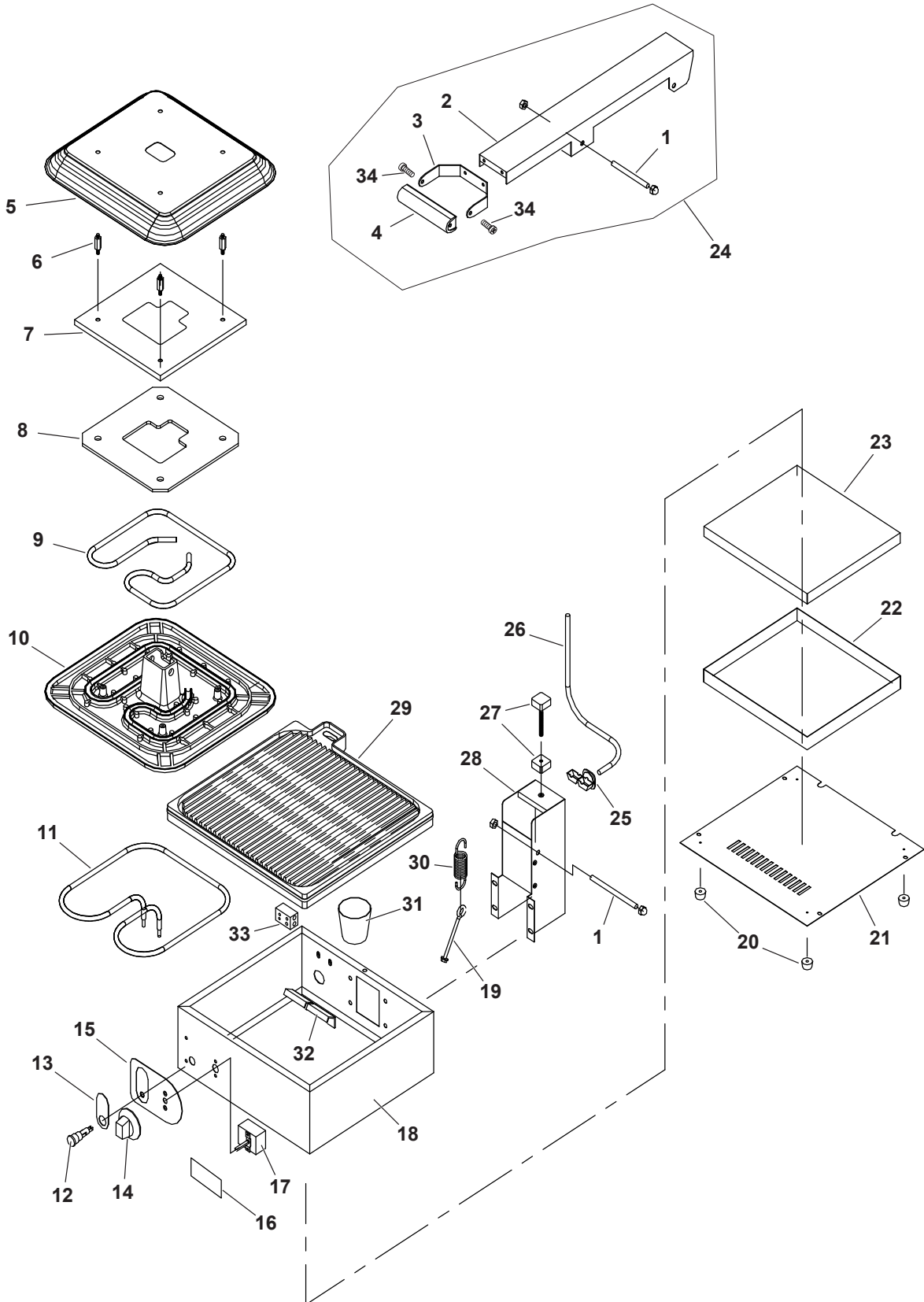

ENGLISH

SPARE PARTS LIST - COUNTERTOP SANDWICH PRESS, MODEL ~ 40793

Callout	Part Number	Description
1	XTSA0013	Handle Pivot Hardware
2	N/A	Top Arm
3	XTSA0050	Handle Bracket
4	XTSA0003	Plastic Handle Grip
5	N/A	Top Cover
6	XTSA0044	Top Plate, Flat, Non-Coated (Model 40793)
7	XTSA0040	Top Heating Element, 120V ~ 800 Watts
8	XTSA0038	Bottom Heating Element 120V ~ 1000 Watts
9	N/A	Light Facia
10	XAA0011	Pilot Light, 120V, Amber
11	XTSA0015	Thermostat Control Knob, Non-Coated (Model 40793)
12	XAA0009	Control Panel Facia
13	XTSA0007	Thermostat, Non-Coated Model 40793
14	N/A	Cover, Bottom, Vented
15	XTSA0004	Foot, Rubber
16	N/A	Press Body
17	XTSA2003	Eye Bolt, Plated
18	N/A	Handle Base
19	XCOA1013	Power Cord Restraint
20	XAA0005	Power Cord, 120V, NEMA 5-15P Plug
21	XTSA0031	Bottom Plate
22	XTSA0001	Handle Spring
23	XTSA0002	Drip Cup
24	N/A	Spring Support Bracket
25	XTSA0051	Screw, for Handle
26	XTSA0029	Handle Assembly, Complete (Includes Ref. No. 1, 2, 3, 4, [qty. 2 of Ref. 25])
26	N/A	Vollrath Logo Decal



EXPLODED VIEW - COUNTERTOP SANDWICH PRESS, MODEL ~ 40793

ENGLISH

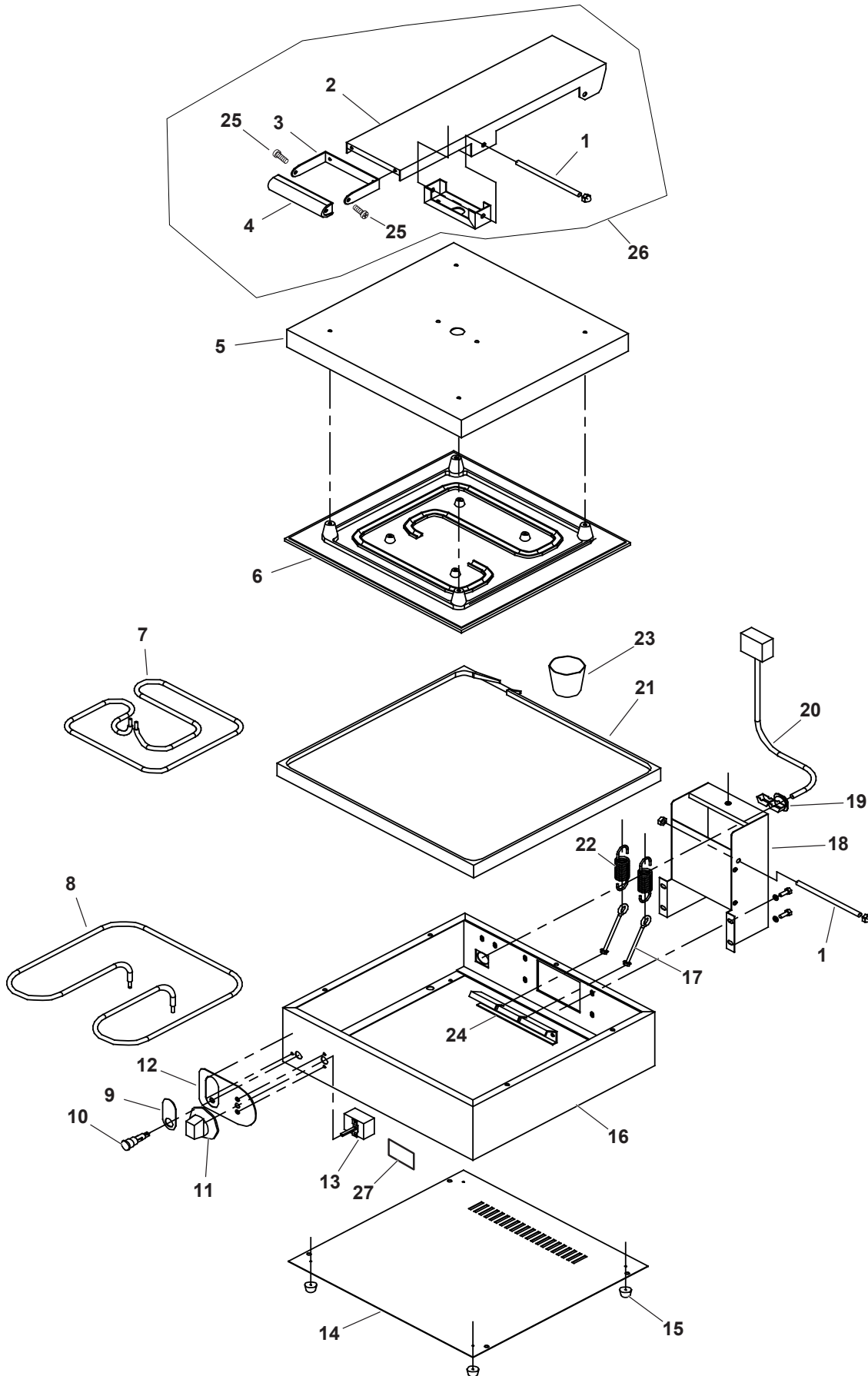

WARRANTY STATEMENT FOR THE VOLLRATH Co. L.L.C.

The Vollrath Company LLC warrants the products it manufactures and distributes against defects in materials and workmanship for a period of one year, except as specifically provided below. The warranty runs 12 months from the date of original installation. (End user receipt)

1. Refrigeration compressors – The warranty period is 5 years.
2. Replacement parts – The warranty period is 90 days.
3. Fry pans and coated cookware – The warranty period is 90 days
4. EverTite™ Riveting System – The warranty covers loose rivets only, forever.
5. Cayenne® Heat Strips – The warranty period is 1 year plus an additional 1 year period on heating element parts only.
6. Intrigue™ Ultra and Professional Induction Ranges – The warranty period is 2 years
7. ServeWell® Induction Workstations – The warranty period is one year on the workstation table and 2 years on induction hobs
8. Slicers – The warranty period is 10 years on gears and 5 years on belts
9. Mixers – The warranty period is 2 years
10. Extended warranties are available at the time of sale.
11. Boxer Mixers – (Vollrath customer base) – 1 Year exchange Warranty
12. Boxer Mixers – (Avantco – Clark Brand) – 3 month replacement
13. Boxer Slicers – (Avantco – Clark Brand) – 3 month replacement

All products in the Jacob's Pride® collection, including the following, have a lifetime warranty:

- NSF Certified One-Piece Dishers
- NSF Certified Spoodle® Utensils
- NSF Certified Heavy-Duty Spoons with Ergonomic Handle
- NSF Certified Heavy-Duty Basting Spoons
- Heavy duty Turners with Ergonomic handle
- One-Piece Tongs*
- Heavy-Duty One-Piece Ladles*
- Nylon Handle Whips
- One-Piece Skimmers
- Tribute®, Intrigue®, and Classic Select® Cookware*

*Jacob's Pride® warranty does not cover Kool-Touch®, non stick coatings and silicone handles.

Items sold having no warranty:

- Meat Grinder Knives
- Light Bulbs in Convection Ovens and Hot Food Merchandiser
- Oven Door Seals
- Oven Door Glass
- Hot Food Merchandisers / Display Case Glass
- Calibration and set up of gas equipment

THIS WARRANTY IS IN LIEU OF ANY OTHER WARRANTIES, EXPRESS OR IMPLIED, INCLUDING ANY IMPLIED WARRANTY OF MERCHANTABILITY OR FITNESS FOR A PARTICULAR PURPOSE

As The Vollrath Company LLC's only responsibility and the purchaser's only remedy, for any breach of warranty, The Vollrath Company LLC will repair or, at its option, replace the defective product or part without charge, except as otherwise provided below:

- For refrigeration compressors and the second year of the warranty on Cayenne® Heat Strips and mixers, The Vollrath Company LLC will provide the repaired or replacement part only; and the buyer will be responsible for all labor charges incurred in performing the repair or replacement.
- To obtain warranty service, the buyer will be responsible to return to The Vollrath Company LLC any product (other than gas equipment that is permanently installed) weighing less than 110 lbs. or located outside of a 50-mile radius of a certified technician designated by The Vollrath Company LLC to perform warranty repairs. If a Vollrath Technician cannot be contacted check the website for service contact points. (Please refer to the Product Catalogue for weights and sizes of product)
- No remedy will be available for products that have been damaged by accident, carelessness, improper installation, lack of proper setup or supervision when required, neglect, improper use, installation or operation contrary to installation and operating instructions or other causes not arising out of defects in materials or workmanship. At the buyer's request, The Vollrath Company LLC will repair and or replace such products at a reasonable cost.
- No remedy will be available for slicers where blade has not been sharpened (Refer to owner's manual for sharpening instructions)
- No remedy will be available for mixers damaged by changing gears while unit is running or overloading, in either case as determined by a Vollrath Certified Technician
- Warranty work must be authorized in advance by The Vollrath Company LLC. See the operating and safety instructions for each product for detailed warranty claim procedures.
- No remedy will be available for product returned and found to be acceptable to the product specification.
- No remedy will be available under any warranty not registered as required below.

LIMITATION OF LIABILITY:

THE VOLLRATH COMPANY LLC SHALL HAVE NO LIABILITY FOR INCIDENTAL OR CONSEQUENTIAL DAMAGES OF ANY KIND, WHETHER BASED UPON NEGLIGENCE OR OTHER TORT, BREACH OF WARRANTY, OR ANY OTHER THEORY.



WARRANTY PROCEDURE

On all warranty calls, the following process and information is required:

- All warranty claims will start with a call to Vollrath Technical Service support line.(800-628-0832).
- A technical support professional will work to diagnose the issues, and provide the details for the service solution.
- Name and phone number of person calling
- Business name, street address, city, state and zip
- Model and serial number
- Date of purchase and proof of purchase (Receipt)
- Name of dealer where unit was purchased

NOTE: Vollrath will not accept products sent without the proper procedure being followed.

Important:

TO MAKE A CLAIM FOR ANY REMEDY UNDER THIS WARRANTY, YOU MUST REGISTER YOUR WARRANTY.

REGISTER TODAY

ONLINE: Register your warranty on-line now at www.Vollrathco.com

NO WEB ACCESS: If you do not have access to the web, kindly register by completing the warranty registration form and faxing it to The Vollrath Co. LLC office in the country of purchase.

WARRANTY REGISTRATION			
BUSINESS NAME			
KEY CONTACT NAME		EMAIL	
STREET ADDRESS			
CITY	STATE	ZIP CODE	
COUNTRY	PHONE	FAX	
MODEL		ITEM NUMBER	
SERIAL NUMBER	<input type="text"/>	-	<input type="text"/>
OPERATION TYPE			
<input type="checkbox"/> Limited Service Restaurant	<input type="checkbox"/> Full Service Restaurant	<input type="checkbox"/> Bars and Taverns	<input type="checkbox"/> Supermarket
<input type="checkbox"/> Convenience Store	<input type="checkbox"/> Recreation	<input type="checkbox"/> Hotel/Lodging	<input type="checkbox"/> Airlines
<input type="checkbox"/> Business/Industry	<input type="checkbox"/> Primary/Secondary School	<input type="checkbox"/> Colleges/University	<input type="checkbox"/> Hospitals
<input type="checkbox"/> Long-Term Care	<input type="checkbox"/> Senior Living	<input type="checkbox"/> Military	<input type="checkbox"/> Corrections
REASON FOR SELECTING OUR PRODUCT			
<input type="checkbox"/> Appearance	<input type="checkbox"/> Full Service Restaurant	<input type="checkbox"/> Availability	<input type="checkbox"/> Sellers Recommendation
<input type="checkbox"/> Ease of Operation	<input type="checkbox"/> Versatility of Use	<input type="checkbox"/> Price	<input type="checkbox"/> Brand
WOULD YOU LIKE TO RECEIVE OUR FULL-LINE CATALOG AND REMAIN ON OUR MAILING LIST?			<input type="checkbox"/> Yes <input type="checkbox"/> No

ENGLISH



www.vollrathco.com

The Vollrath Company, L.L.C.
1236 North 18th Street
Sheboygan, WI 53081-3201
U.S.A.
Main Tel: 800.628.0830
Service Tel: 800.628.0832
FAX: 800.752.5620

Vollrath of Canada, Co.
Tel: 800.695.8560
FAX: 800.752.5620

© 2010 The Vollrath Company, L.L.C.

