



The Vollrath Company, L.L.C.  
1236 North 18<sup>th</sup> Street  
P.O. Box 611  
Sheboygan, WI 53082-0611  
Telephone 920 457-4851

# Operating and Safety Instructions

## TW 27R & TSM 27

### Model Numbers:

72028 - TW 27R, 1400 Watts, 120 Volts

72030 – TSM 27, 1400 Watts, 120 Volts

72031 – TSM 27, 1400 Watts, 120 Volts, With Canopy

72032 – TSM 27, 1470 Watts, 120 Volts, With Canopy and Lights



## TW 27 R & TSM 27

Thank you for purchasing this Vollrath food rethermalizer/warmer. Before operating this unit, read and familiarize yourself with the following operating and safety instructions. SAVE THESE INSTRUCTIONS FOR FUTURE REFERENCE.

### WARNING

**ELECTRIC SHOCK, FIRE OR BURN INJURIES CAN OCCUR IF THIS EQUIPMENT IS NOT USED PROPERLY. TO REDUCE RISK OF INJURY:**

- Plug only into grounded electrical outlets matching the nameplate rated voltage.
- Unit should only be used in a flat, level position.
- Unplug warmer and let cool before cleaning or moving.
- Do not spray controls or outside of unit with liquids or cleaning agents.
- Handle hot water carefully.
- Do not immerse
- Unplug warmer when not in use
- Do not operate unattended

**IMPORTANT:** Always operate this unit with water in the well

### **Function and Purpose:**

This unit is intended to rethermalize containers of previously cooked food and hold containers of hot food at a safe serving temperature. This unit is not intended or designed to cook raw food product.

### **Installation:**

This unit is to be used on a countertop. This unit is not designed be enclosed or built into any area.

### **Operation :**

1. Place the food merchandiser on a flat, level surface. This unit is not designed to be enclosed or built in any area.
2. Fill each well with **1 quart of water**. Do not overfill wells. **Always maintain water in well.**

### WARNING

#### **ELECTRICAL SHOCK HAZARD**

**Keep water level at approx. 1 quart. If level is too high, water may overflow when the food container is inserted. The overflow could enter the electrical compartment and cause a short circuit or electric shock.**

3. Plug power cord into grounded electrical outlet with the nameplate rated voltage.

** WARNING  
BURN HAZARD**

**Hot water and steam in the well can burn skin.  
Use protective gloves, mitts or potholders when removing  
food containers or covers. Hot food can also cause burns. Handle hot food carefully.**

4. Operation of:

**Hot Food Holding**

1. Preheat the water in the wells by covering wells with empty food containers or covers, and then setting the heat control to the maximum heat setting.  
***Preheat for 15 minutes***
2. Place container of hot food product into preheated food merchandiser. Reduce heat setting and monitor food temperatures closely for food safety. (See food safety precautionary note below)
3. Maintain water level at or near water level mark. Periodically (approximately 2 hours) remove container of food and check the water level. Add hot water if needed.

**Rethermalizing refrigerated food that has been previously cooked**

1. Preheat the water in the wells by covering wells with empty food containers or covers, and then setting the heat control to the maximum heat setting.  
***Preheat for 1 hour***
2. Set the timer to 1 (one) hour for rethermalizing. (TW 27R Only)
3. During the rethermalization process, monitor food temperatures closely for food safety. The United States Public Health Service recommends that the entire food product reaches and maintains a minimum of 165°F (74°C) for at least 15 seconds to be properly rethermalized. In addition, rethermalized food must pass through the danger zone of 41°F (5°C) to 165°F (74°C) in less than 2 hours to prevent growth of organisms of public health concern. **Do not add cold food for rethermalizing while holding hot food; the merchandiser will cool down and not hold the hot food at proper serving temperature.** To reach the required safe food temperature as quickly as possible, do not add water or remove food pan during the rethermalization process.

5. Reduce heat setting to a level that will maintain a safe holding temperature and maintain food quality. (See Food Safety Precautionary Note)

### **FOOD SAFETY PRECAUTIONARY NOTE**

*Monitor food temperatures closely for food safety. The United States Public Health Service recommends that food be held at a minimum of 140°F (60°C) to help prevent bacteria growth. Maintain water level at approximately 1 quart. Water level MUST be sufficient to completely submerge the element. Periodically (approx. 2 hours) remove container of food and check the water level. Add hot water if needed.*

#### **Cleaning:**

To maintain appearance and increase the service life, the food warmer should be cleaned at least daily.

1. Before cleaning unplug the unit and let it and any liquid in the unit cool completely.



#### **WARNING BURN HAZARD**

**Hot water and hot parts can burn skin.  
Allow hot wells and water to cool before handling.**

2. Carefully empty water from the wells.
3. Wipe the entire well interiors with a clean, damp cloth.
4. To avoid damaging the finish, do not use abrasive materials, scratching cleaners or scouring pads to clean water deposits from the wells.
5. If soap or chemical cleaners are used, be sure they are completely rinsed away with clear water, immediately after cleansing. Chemical residue could corrode surface of unit.



#### **WARNING ELECTRICAL SHOCK HAZARD**

**Do not spray outside of unit or controls with liquid or cleaning product. Liquid could enter the electrical compartment and cause a short circuit or electric shock.**

**Trouble Shooting:**

<b>Symptom</b>	<b>Probable Cause</b>
Unit operates on HIGH continuously	When the timers are used to rethermalize cold food (TW 27R only), the unit will operate on high and not respond to changes in the thermostat. When the timers cycle off and rethermalization is complete, the thermostat will then regulate the temperature of the unit to the setting of the thermostat. The timers should not be used for hot holding operation.
The pilot light turns off when the unit should be working	The light indicates when there is power to the element. It will cycle on and off with the element.
The lights on the TSM 27 do not turn on	The lights have an independent ON/OFF Switch and power cord that can be plugged into the back of the unit or into another source. Be sure the lights are plugged in and the switch is turned on.

**Repair:**

There are no user serviceable parts within this appliance. To avoid serious injury or damage, never attempt to repair the food warmer/rethermalizer or replace a damaged power cord yourself. Contact a qualified professional repair service.

**Exploded View TSM 27:**

ITEM NO.	QTY.	PART NO.	DESCRIPTION	ITEM NO.	QTY.	PART NO.	DESCRIPTION
1	1	144171	Bottom Plate	34	2	13744	EDGING
2	1	144172	Back Panel Assy	35	2	13772	Label - Control
3	1	144172	Front Panel Assy	36	2	13782	Ferrule Ring (Not Shown)
4	2	144174	Side Panel Assy	37	2	13783	SLEEVING (NOT SHOWN)
5	2	17559	Power Indicator Lmbd 120vac	38	3	25181	#6 INTERNAL LOCK WASHER
6	2	17074	THERMOSTAT, SHORT CAPILLARY	39	6	13704	SCREW, #10-32 X .625 THREAD ROLLING
7	4	17416	Phenolic Foot	40	1	13748	RATING LABEL - NSF
8	1	17045	Strain Relief	41	4	23475	TRICNUT, 1/4-20 UNC
9	12	23095	Rivet, Pop - .125 Dia.				
10	1	26549	Power Receptacle				
11	4	17686	SCREW, M6-0.7 X 5MM				
12	5	17020	SCREW, #6-32 X .500				
13	7	17039	Nut, 6-32 Kep				
14	2	17507	WELL, GREY PLASTIC				
15	2	17504	Thermostat, High Limit				
16	2	23090	RIVET, POP - .125 DIA.				
17	12	45835	Well Mount Bracket				
18	14	17018	SCREW, 8-32 X .5				
19	1	17747	WIRE HARNESS (NOT SHOWN)				
20	1	17305	LABEL - HOT SURFACE				
21	1	17799	Label, Outlet				
22	1	17774	Label, Rating				
23	1	17023	CORD SET				
24	1	144170	Top Plate				
25	10	17118	NUT, HEX, 10-32 ZINC PLATED				
26	2	17021	O-Ring				
27	2	44459	Hi-Limit Plate				
28	4	17741	LOOP CLAMP				
29	2	17388	KNOB, CONTROL				
30	2	44204	HEATER ELEMENT, 700W				
31	10	17307	SCREW, #8-32 X .25 LG.				
32	4	21775	#8-32 TRUSS HEAD .500 LG.				
33	4	17496	SCREW, #6-32 X .250				

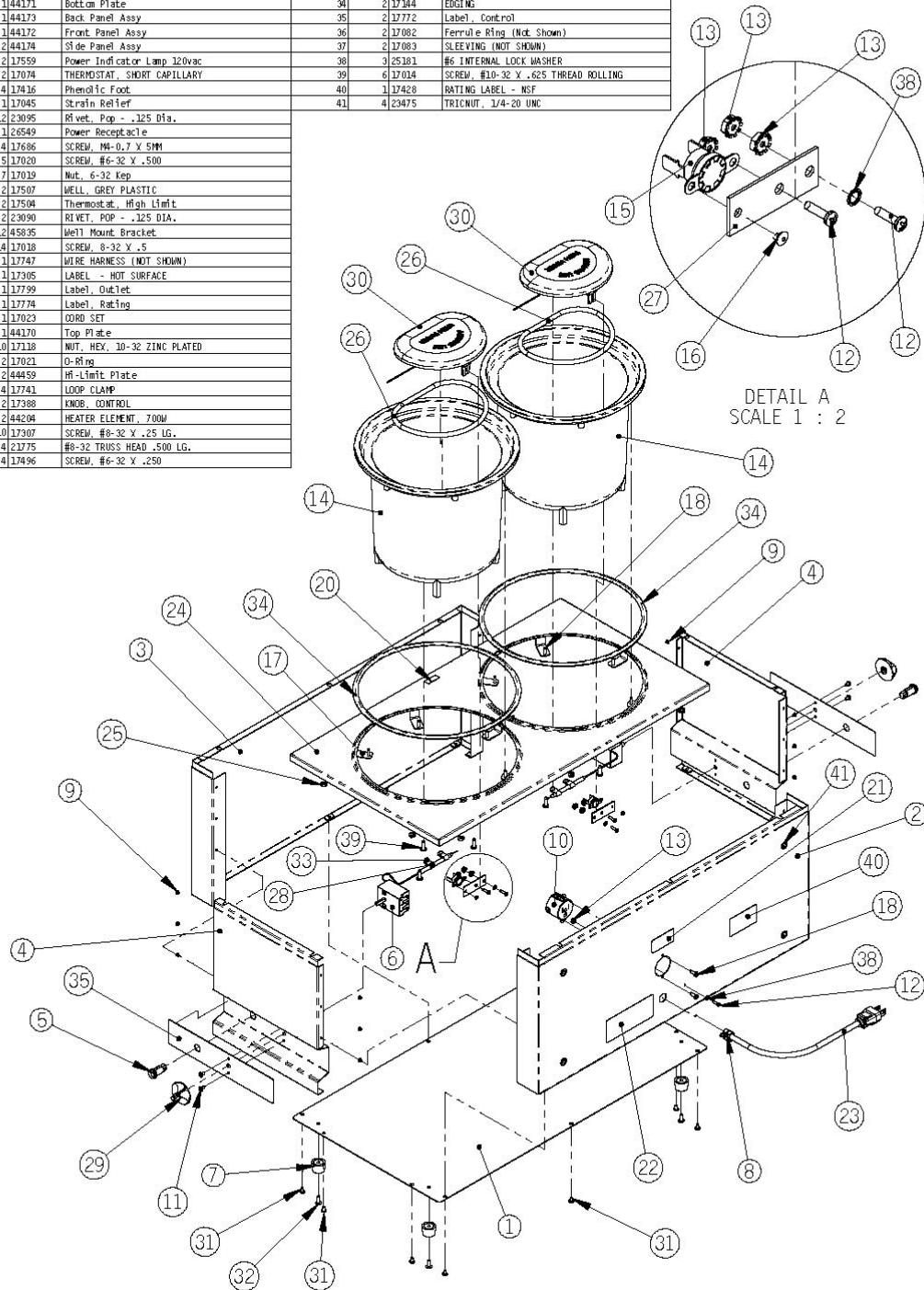

## Exploded View TW 27

ITEM NO.	QTY.	PART NO.	DESCRIPTION	ITEM NO.	QTY.	PART NO.	DESCRIPTION
1	1	144261	TOP PLATE ASSEMBLY	34	1	17747	WIRE HARNESS (NOT SHOWN)
2	2	17091	WELL, BLACK PLASTIC	35	2	17074	THERMOSTAT, SHORT CAPILLARY
3	2	45835	MOUNTING BRACKET	36	4	17388	KNOB, CONTROL
4	24	17018	SCRBJ, 8-32 X .500	37	2	17741	LOOP CLAMP
5	2	44204	HEATER ELEMENT, 700W	38	4	17686	SCREW, #8-0.7 X 5MM
6	2	17021	O-ring	39	2	17082	FERRULE RING (NOT SHOWN)
7	2	17344	EDGING	40	2	17083	SLEEVING (NOT SHOWN)
8	2	44314	THERMOSTAT DISSIPATOR BRACKET, LEFT	41	6	17014	SCREW, #10-32 X .625 THREAD ROLLING
9	2	25438	Thermostat, Regulating	42	2	17117	SCREW, #10-32 X .25 LG.
10	2	17504	SWITCH, HIGH LIMIT				
11	3	25181	#6 INTERNAL STAR				
12	4	17222	SCRBJ, #4-40 X .375				
13	4	21323	#4-40 KEPS LOCK NUT				
14	2	26674	WASHER, SPLIT LOCK				
15	2	17492	SCRBJ, #8-32 X .5 LG.				
16	2	23685	NUT, LOCK - #8-32				
17	3	17020	SCRBJ, #10-32 X .25 LG.				
18	7	17019	#6-32 KEPS NUT				
19	1	44374	BACK PANEL				
20	1	44251	FRONT PANEL				
21	2	44270	SIDE PANEL				
22	2	17342	KNOB GUARD				
23	2	17620	TIMER				
24	1	44252	BOTTOM PANEL				
25	16	23090	RIVET, POP - .325 DIA.				
26	4	17416	LEG, PHENOLIC (BLACK)				
27	4	23097	RIVET, POP - .387 DIA, ALUMINUM				
28	1	17045	STRAIN RELIEF				
29	1	17023	CORD SET				
30	1	17827	PANEL LABEL				
31	4	17307	SCRBJ, #8-32 X .25 LG.				
32	2	17559	LIGHT, PILOT				
33	6	17118	NUT, HEX, 10-32 ZINC PLATED				

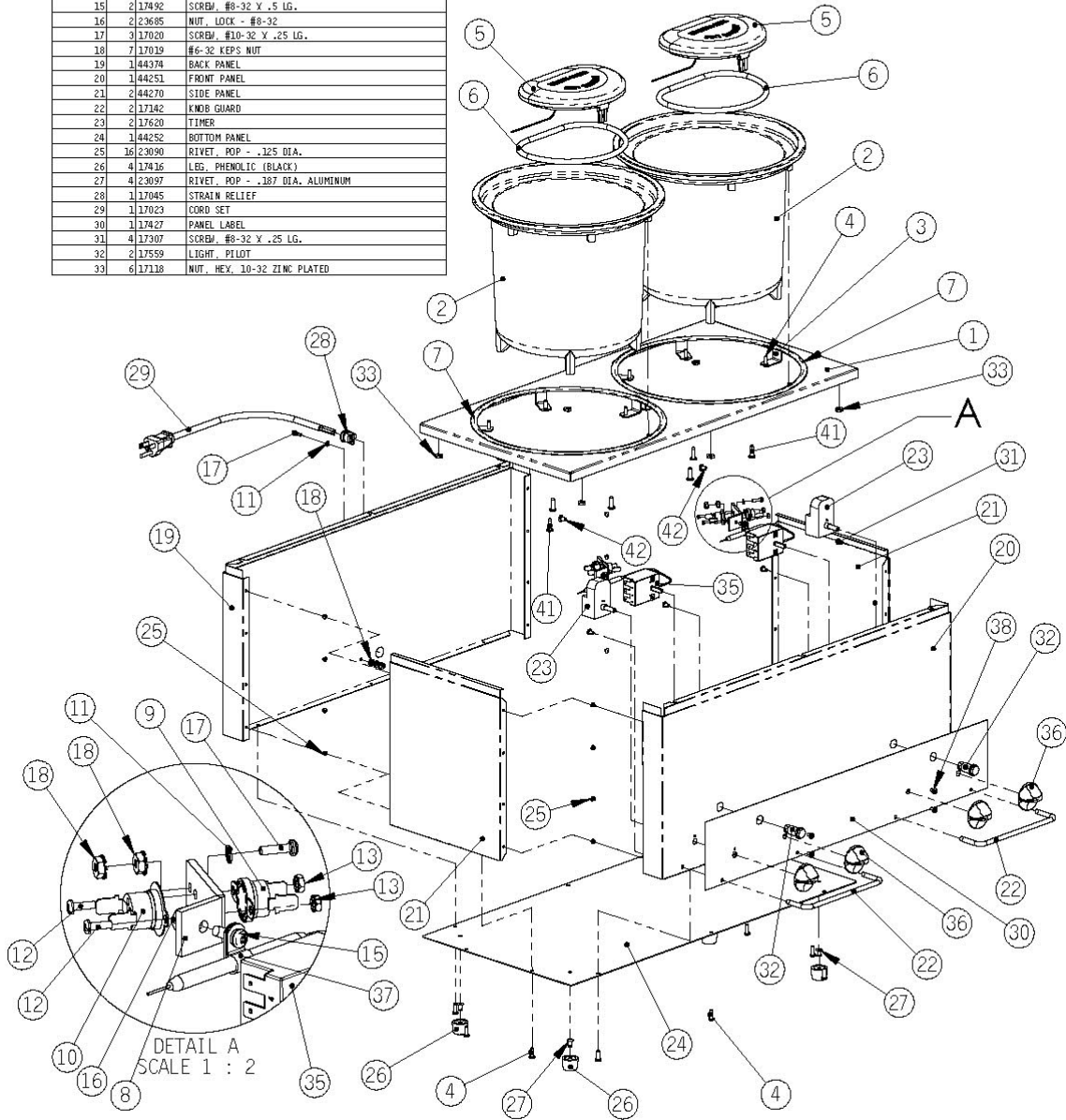

### 72031 Menu Board Assembly

#### Parts List:

1. Mounting bracket (Assembled to Menu Board, 4 places)
2. Menu Board with Decal
3. Decal (Not Shown), Affixed to Menu Board
4. Washer 1/4"
5. Bolt 1/4" x 20 x 1.5"
6. Straight Post
7. End Cap 4 pcs (Already Assembled)

#### Installation and Assembly:

1. Mount straight posts to warmer back with bolts and washers. Tighten bolts finger tight only.
2. Make sure there is no dirt, oil or grease on the posts. Remove backing from double sided tape that is in the mounting bracket sections. Position menu board so top is slightly above the plastic caps on the top end of the posts. Press menu board assembly to the posts securely.
3. Tighten bolts with wrench.

---

## 72032 Lighted Canopy Assembly Instructions

### Parts List:

1. Canopy Decal, Not Shown
2. Canopy
3. Light Bracket (Assembled to light and canopy)
4. Halogen Light (Assembled to Bracket)
5. Menu Board Decal, Not Shown
6. Menu Board
7. Posts (2)
8. Mounting bracket (Assembled to menu board, 4 places)
9. Post End Caps, (4) (Assembled to Posts)
10. Bolt,  $\frac{1}{4}$ " x 20 x 1.5", (4)
11. Washer,  $\frac{1}{4}$ ", (4)

### Assembly:

1. Assemble posts to back of warmer unit with bolts and washers. Tighten finger tight only.
2. Make sure there is no grease, oil or dirt on the posts. Remove backing from double sided tape from the inside of the light bracket channels (2 places). Mount canopy assembly to posts by pressing bracket down over the posts. Position canopy so front edge is closest to the post end caps.
3. Remove the backing from the double sided tape on the menu board. Position menu board approximately 1" (25 mm) above top edge of warmer. Press firmly into place.
4. Tighten bolts from step #1 with wrench.

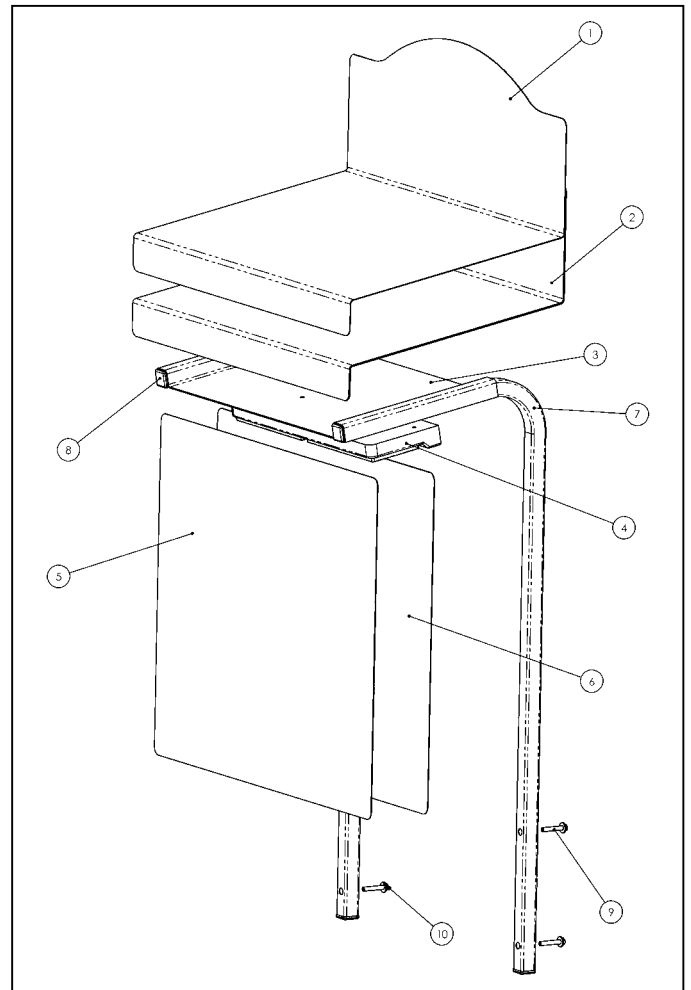

## Warranty Policy for The Vollrath Co. L.L.C.

The Vollrath Company L.L.C. warranties all products it manufactures and distributes against defects in materials and workmanship for a period of one year - except as listed below, from the date of purchase to the original purchaser under normal use and service. All warranties are void if the product has been damaged by accident, neglect, improper use or other causes not arising out of defects in materials or workmanship.

- Refrigeration compressors – 5 year warranty
- Intrigue & Classic Select cookware – Limited lifetime warranty
- Replacement parts – 90 (ninety days) on the part only
- Fry pans and coated cookware – 90 (ninety days)

The Vollrath Company shall not be liable for loss of use of the product or other incidental or consequential costs, expenses or damage incurred by the purchaser.

Warranty work must have prior approval from The Vollrath Company.

## Warranty Procedure for Countertop Equipment

During the warranty period the food warmer will be replaced without charge to the original purchaser when returned prepaid and insured, with proof of purchase date, to the dealer who originally sold the unit. Should it become necessary to return this product to The Vollrath Company, **you must first obtain return authorization and shipping instructions from The Vollrath Company Customer Service Department.** Please have model number and serial number information available when calling.

- Carefully pack the item in its original carton or other suitable box to avoid shipping damage.
- Attach a tag to the item before packing with your name, complete address and phone number, model and serial number, purchase information and an explanation of the problem. Include **RETURN AUTHORIZATION PACKING SLIP.**
- We recommend you insure the package, as shipping damage is not covered under warranty.

Mailing address:  
The Vollrath Company L.L.C.  
1236 N. 18<sup>th</sup> Street  
Sheboygan, WI 53081

PLEASE ALLOW 30 – 45 DAYS FOR REPLACEMENT WARMER

RETURNS WITHOUT PRIOR AUTHORIZATION WILL NOT BE ACCEPTED