

**VOLLRATH** GAS HOT PLATE, 12"

ITEM NO./MODEL NO.	DESCRIPTION
HPG2-12	GAS HOT PLATE, 12"

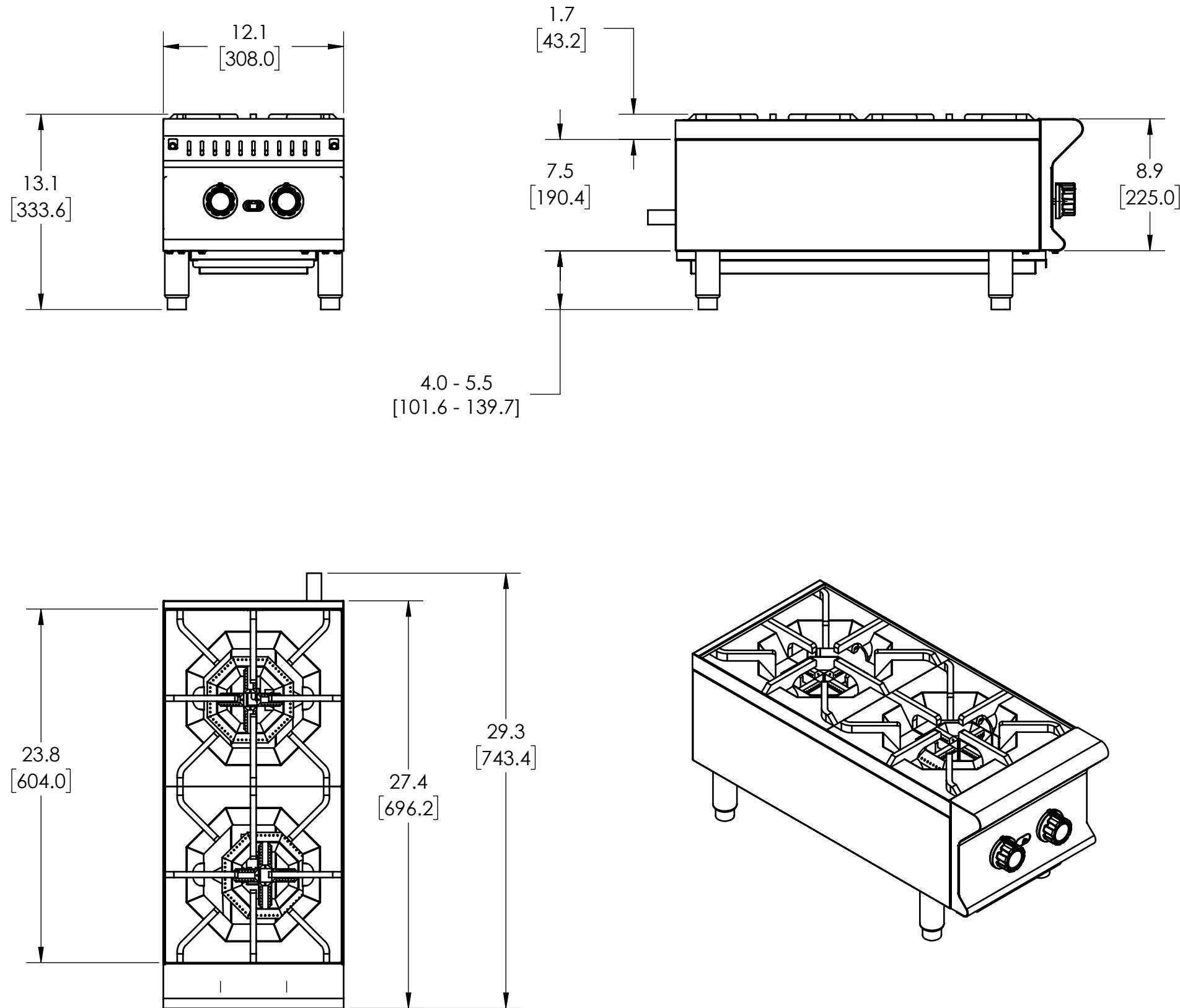

NOTE:

1. OUTPUT IS 52,000 BTU.
2. UNIT SHOULD BE INSTALLED UNDER A HOOD IN ACCORDANCE WITH THE LATEST EDITION OF THE STANDARD FOR VENTILATION CONTROL AND FIRE PROTECTION OF COMMERCIAL COOKING OPERATIONS, NFPA 96.
3. STANDING PILOTS WITH A MANUAL BURNER CONTROL VALVE FOR EACH BURNER. 3/4" NPT GAS INLET.
4. UNIT WEIGHT IS: 55.1 LBS.
5. MATERIALS: STAINLESS STEEL AND PRE-SEASONED CAST IRON.
6. CERTIFICATIONS:
  1. ANSI Z83.11:2016.
  2. CSA 1.8:2016.
  3. NSF/ANSI 4.



DIMENSIONS ARE IN INCHES (IN) UNLESS OTHERWISE NOTED.  
 DIMENSIONS IN BRACKETS ARE IN MILLIMETERS (MM) AND ARE FOR REFERENCE ONLY.

ITEM NO./MODEL NO.	DESCRIPTION
HPG2-12	GAS HOT PLATE, 12"

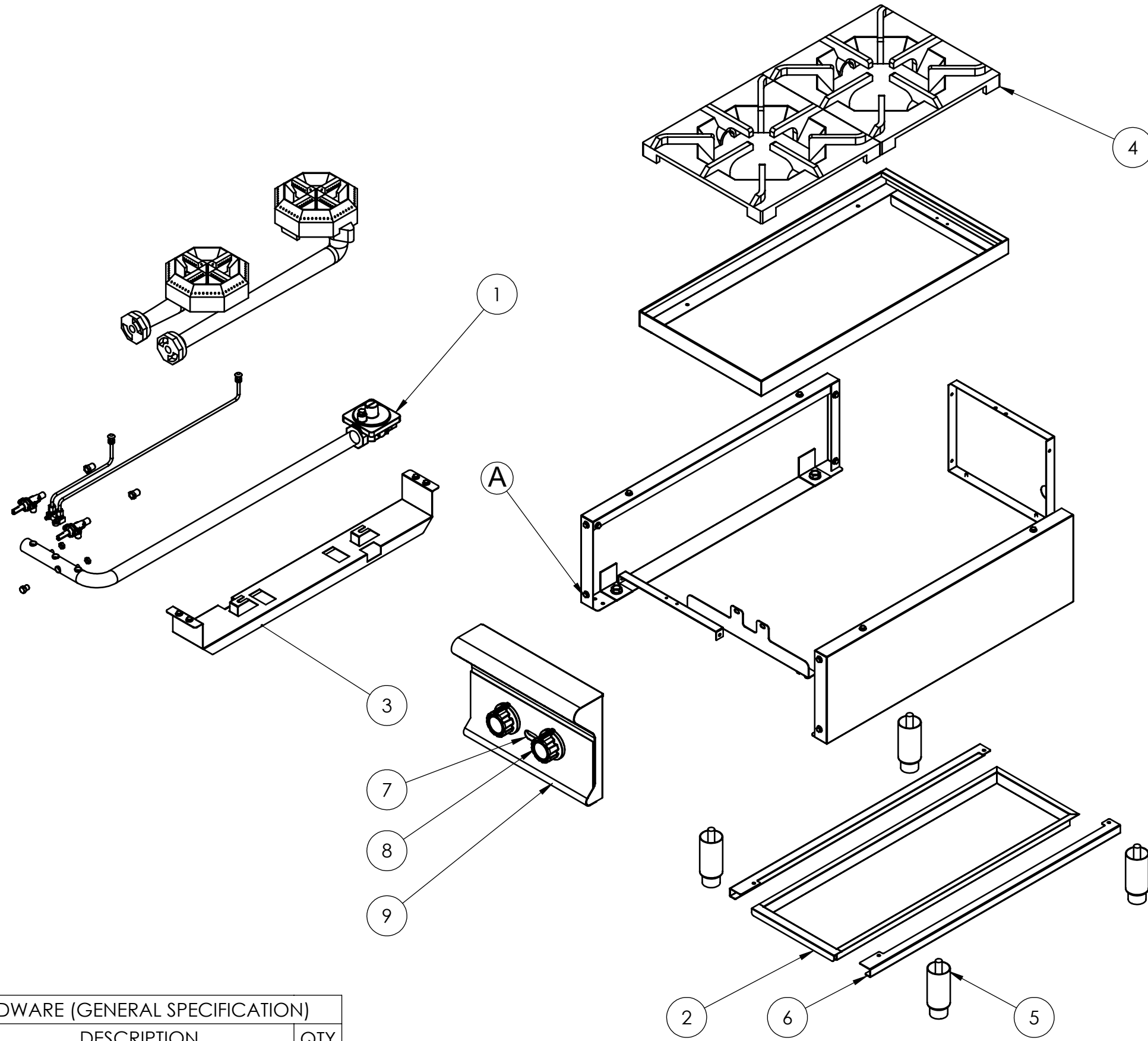

HARDWARE (GENERAL SPECIFICATION)		
SN	DESCRIPTION	QTY
A	M5X0.8X10 SS TAP SCREW, FL HEX	32

SN	PART NO	DESCRIPTION	QTY
1	353374-1	REGULATOR 4IN WC	1
2	353365-1	DRIP TRAY - 12IN HP-MDCB	1
3	353363-1	BURNER SUPPORT - HOT PLATE	1
4	353362-1	HOT PLATE TOP GRATE	2
5	353376-1	LEG, GAS APPLIANCE	4
6	353366-1	DRIP TRAY SUPPORTS - HP	1
7	353361-1	FASCIA - OVERLAY 12IN HOT PLATE	1
8	353373-1	CONTROL KNOB LG INSERT	2
9	354215-1	HPG2-12 FRONT PANEL ASSY	1

ITEM NO./MODEL NO.	DESCRIPTION
HPG2-12	GAS HOT PLATE, 12"

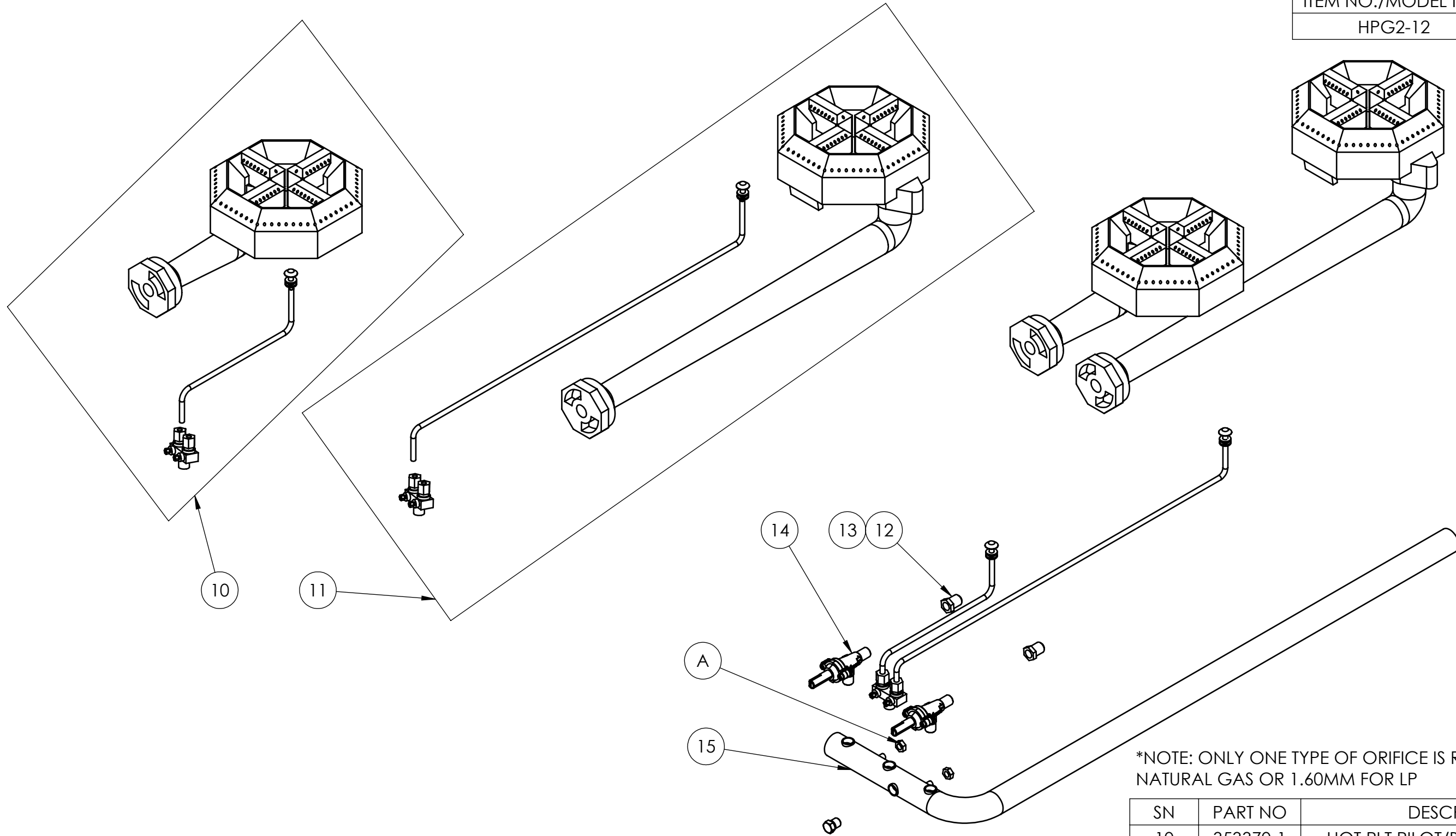

\*NOTE: ONLY ONE TYPE OF ORIFICE IS REQUIRED, 2.40MM FOR NATURAL GAS OR 1.60MM FOR LP

HARDWARE (GENERAL SPECIFICATION)		
SN	DESCRIPTION	QTY
A	M6X1X5 SS HEX NUT	2

SN	PART NO	DESCRIPTION	QTY
10	353370-1	HOT PLT PILOT/BRN ASSY - FRONT	1
11	353371-1	HOT PLT PILOT/BRN ASSY - REAR	1
12	353368-1	2.40MM BRASS ORIFICE *	2
13	353369-1	1.60MM BRASS ORIFICE *	2
14	353367-1	MANUAL CONTROL VALVE	2
15	353372-1	12" HOT PLATE MANIFOLD	1