



Frozen Beverage Dispensers
EVERYONE LOVES FROZEN™

FBD Partnership, LP

- P.O. BOX 18597 • SAN ANTONIO, TX 78218 USA •
- 210-637-2800 • FAX 210-637-2844 • www.fbdfrozen.com •
- FBD TECHNICAL SUPPORT • 1-866-323-2777 •
- TECHNICAL SUPPORT FAX 1-210-637-2832 •

INSTALLATION AND OPERATION MANUAL FOR THE MODEL FBD56X SERIES FROZEN BEVERAGE DISPENSERS

***THIS MANUAL APPLIES TO FROZEN BEVERAGE DISPENSERS
IN THE 562, 563 AND 564 SERIES.***

THIS DOCUMENT CONTAINS IMPORTANT INFORMATION.

***This manual must be read and understood
BEFORE the installation and operation of the dispenser.***

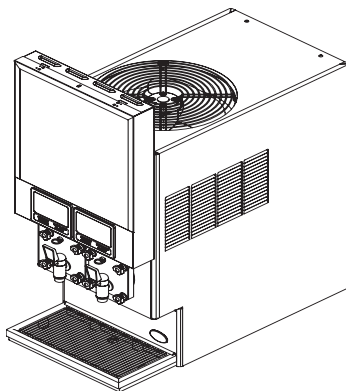

FBD562

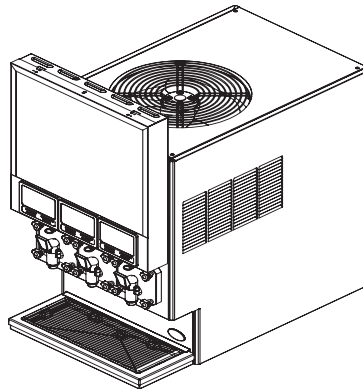

FBD563

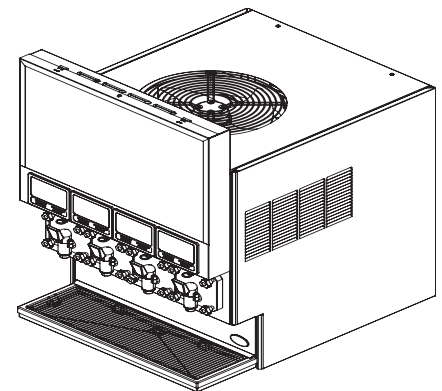

FBD564

NOTICE:

The information contained in this document is subject to change without notice.

FBD MAKES NO WARRANTY OF ANY KIND WITH REGARD TO THIS MATERIAL, INCLUDING, BUT NOT LIMITED TO, THE IMPLIED WARRANTIES OF MERCHANTABILITY AND FITNESS FOR A PARTICULAR PURPOSE. FBD shall not be liable for errors contained herein or for incidental consequential damages in connection with the furnishings, performance, or use of this material.

This document contains proprietary information which is protected by copyright. All rights reserved.

©2014 FBD Partnership, LP. All Rights Reserved.

***This manual supersedes and replaces 24-2280-0001/Rev 03, dated 03/27/12,
and is designated as Revision 04.***

Please refer to the FBD web site (www.fbdfrozen.com) for information relating to FBD Installation, Operation and Service Manuals, Instruction Sheets, Technical Bulletins, Service Bulletins, etc.

REV LEVEL 04: 02/25/14
FBD Part Number: 24-2280-0001

SPECIFICATIONS FOR THE FBD562 DISPENSER

DIMENSIONS

Width	17.0 inches	(432 mm)
Depth	32.3 inches	(820 mm)
Height (Standard Countertop Unit)	41.4 inches	(1054 mm)
Height (Optional Roll Around Unit/Stand)	75.4 inches	(1918 mm)

WEIGHT

Shipping	395 pounds	(179.2 kg)
Empty	318 pounds	(144.2 kg)
Operational	345 pounds	(156.5 kg)

WATER REQUIREMENTS

Minimum flowing pressure	30 psig	(207.0 kPag)
Maximum static pressure	70 psig	(483.0 kPag)

CARBON DIOXIDE (CO₂) REQUIREMENTS

Minimum pressure	70 psig	(482.6 kPag)
Maximum pressure	72 psig	(496.4 kPag)

SPECIFICATIONS FOR THE FBD563 DISPENSER

DIMENSIONS

Width	20.3 inches	(516 mm)
Depth	32.3 inches	(820 mm)
Height (Standard Countertop Unit)	41.4 inches	(1054 mm)
Height (Optional Roll Around Unit/Stand)	75.4 inches	(1918 mm)

WEIGHT

Shipping	415 pounds	(188.2 kg)
Empty	365 pounds	(166.0 kg)
Operational	390 pounds	(177.0 kg)

WATER REQUIREMENTS

Minimum flowing pressure	30 psig	(207.0 kPag)
Maximum static pressure	70 psig	(483.0 kPag)

CARBON DIOXIDE (CO₂) REQUIREMENTS

Minimum pressure	70 psig	(482.6 kPag)
Maximum pressure	72 psig	(496.4 kPag)

SPECIFICATIONS FOR THE FBD564 DISPENSER

DIMENSIONS

Width	26.0 inches	(660 mm)
Depth	32.3 inches	(820 mm)
Height (Standard Countertop Unit)	41.4 inches	(1054 mm)
Height (Optional Roll Around Unit/Stand)	75.4 inches	(1918 mm)

WEIGHT

Shipping	500 pounds	(226.8 kg)
Empty	410 pounds	(185.9 kg)
Operational	460 pounds	(208.7 kg)

WATER REQUIREMENTS

Minimum flowing pressure	30 psig	(207.0 kPag)
Maximum static pressure	70 psig	(483.0 kPag)

CARBON DIOXIDE (CO₂) REQUIREMENTS

Minimum pressure	70 psig	(482.6 kPag)
Maximum pressure	72 psig	(496.4 kPag)

SAFETY PRECAUTIONS

We at FBD are concerned about your safety. Please carefully read the following precautions before working with the FBD56x units. This will familiarize you with proper equipment handling techniques.

LIFTING

- To avoid personal injury or damage, do not attempt to lift the unit without help. The use of a mechanical lift is recommended
 - The empty **FBD562** unit weighs approximately 318 pounds (144.2 kg).
 - The empty **FBD563** unit weighs approximately 365 pounds (166.0 kg).
 - The empty **FBD564** unit weighs approximately 410 pounds (185.9 kg).
- Use gloves to protect hands from being injured by the edges of cross bracing if lifting by hand.
- Use proper equipment and lifting techniques when lifting or moving equipment. *The unit is top heavy.* Maintain unit in a vertical, upright position when lifting and positioning the unit.

ELECTRICAL

- This unit must be properly electrically grounded to avoid possible fatal electrical shock or serious injury to the operator. The power cord is provided with a three prong grounded plug. If a three-hole grounded electrical outlet is not available, use an approved method to ground the unit. *Only qualified electricians should perform this task and the work performed should meet all applicable codes.*
- Always disconnect electrical power to the unit to prevent personal injury before attempting any internal maintenance. Only qualified personnel should service internal components of electrical wiring.

CARBON DIOXIDE (CO₂)

- CO₂ (carbon dioxide) displaces oxygen. Strict attention must be observed in the prevention of CO₂ gas leaks in the entire CO₂ and soft drink system. If a CO₂ gas leak is suspected, immediately ventilate the contaminated area before attempting to repair the leak. Personnel exposed to high concentrations of CO₂ gas will experience tremors which are followed rapidly by loss of consciousness and suffocation.
- To avoid personal injury and/or property damage, always secure CO₂ cylinders in an upright position with a safety chain to prevent cylinders from falling over. Should the valve become accidentally damaged or broken off, a CO₂ cylinder can cause serious personal injury.

QUICK REFERENCE SHEET FOR INSTALLING FBD UNITS

NOTE:

This guide is for quick reference only. It is not intended to replace important detailed information contained in this Installation, Operation and Service Manual. Thoroughly read the entire manual before attempting installation.

Checkpoints

- Verify the line voltage is between 215 VAC and 245 VAC.
- Adjust the voltage offset to make the line voltage and the voltage on the display match.
- Adjust the CO2 secondary regulator to between 28 and 32 psig.

NOTE:

If this is a low carbonation application, the CO2 secondary regulator should be set to between 17 and 19 psig and requires special software.

- Verify on the unit's display that the CO2 and syrup pressures are at about 70 psig static.
- Verify the water pressure is about 70 psig static for a SHURflo pump and between 85 and 90 psig for a Flojet pump.
- Adjust the water flow rate to 1.5 ounces per second.
- Adjust the Brix to between 13.5 and 15.0.
- Fill barrels with product.
- Press "DEF" and then "RUN" for each barrel. There will be a two (2) minute delay before the compressor starts. The freeze down will take between 8 to 10 minutes.

See Sections 4 through 6 of this manual for further details on each of these checkpoints and dispenser installation.

NOTE:

If the unit has been in storage for longer than 90 days, FBD recommends that the rear seals be replaced.

OPERATING REQUIREMENTS

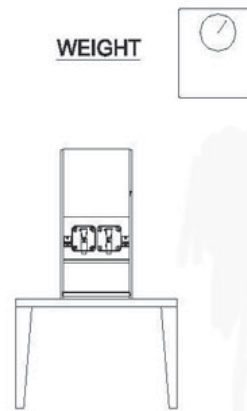
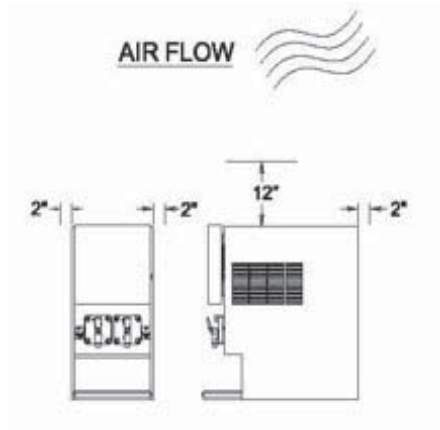

- 550: 345 LB (156 Kg)
- 562: 345 LB (156 Kg)
- 553: 370 LB (168 Kg)
- 563: 390 LB (177 Kg)
- 564: 460 LB (209 Kg)
- 554: 634 LB (288 Kg)

POWER 

- 550: 215-245 VAC, 30 A, 1 PH
- 562: 215-245 VAC, 20 A, 1 PH
- 553: 215-245 VAC, 30 A, 1 PH
- 563: 215-245 VAC, 20 A, 1 PH
- 564: 215-245 VAC, 30 A, 1 PH
- 554: 215-245 VAC, 50 A, 1 PH

C02 

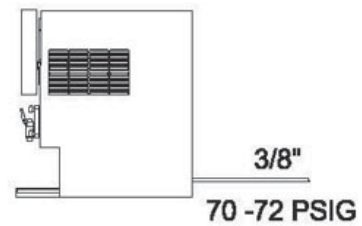

SYRUP 

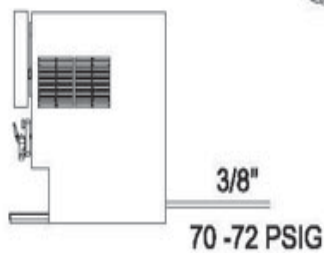

H2O 

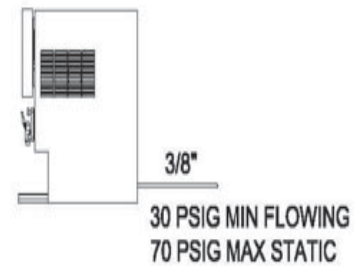

TABLE OF CONTENTS

SPECIFICATIONS	2-3
SAFETY PRECAUTIONS	3
QUICK REFERENCE SHEET FOR INSTALLING FBD UNITS	4-5
TABLE OF CONTENTS	6-7
1. PREPARING THE LOCATION	7
1.1 LOCATION REQUIREMENTS	7
1.2 ADDITIONAL REQUIREMENTS	7
2. RECEIVING AND UNPACKING UNIT	7
2.1 RECEIVING	7
2.2 UNPACKING	7
3. INSTALLING THE UNIT	8
3.1 FLUSH MOUNTING	8
3.2 ROLL AROUND CART	8
4. CONNECTING TO ELECTRICAL POWER	8
5. CONNECTING WATER, CO₂, AND SYRUP SUPPLIES	9
5.1 WATER SUPPLY	9
5.2 CO ₂ SUPPLY	10
5.3 SYRUP SUPPLY	10
6. STARTING THE UNIT	11
6.1 INITIAL POWER-UP	11
6.2 BRIXING	12
6.3 FILLING THE CHAMBER	13
CRITICAL REGULATOR AND FLOW CONTROL SETTINGS	14
7. OPERATION OF THE DISPENSER	15
7.1 OPERATING ELECTRONIC CONTROLS	15
7.2 MACHINE ACCESS	19
7.3 MACHINE SETTINGS	20
7.4 READOUTS	21
8. CLEANING AND SANITIZING THE UNIT	21
8.1 GENERAL INFORMATION	21
8.2 REQUIRED CLEANING EQUIPMENT	22
8.3 DAILY CLEANING OF THE UNIT	22
8.4 SANITIZING THE SYRUP SYSTEMS	22
8.5 PREVENTIVE MAINTENANCE	23
8.6 CLEANING THE AIR FILTER	23
9. BASICS OF OPERATION	23
9.1 MAKING ADJUSTMENTS TO THE FBD56X SERIES UNITS	23
10. CHANGING FACTORY SET “LEVEL CONTROL”	25
10.1 BEFORE CHANGING “LEVEL CONTROL” SETTINGS	25
10.2 DRINK TOO HARD AND COLD	25
10.3 DRINK TOO LIQUID	25
10.4 CHANGING THE DEFAULT LEVEL CONTROL SETTING	26
11. CHANGING FACTORY THAW AND FREEZE SETTINGS	26
11.1 BEFORE CHANGING THAW AND FREEZE SETTINGS	26
11.2 CHANGING THAW AND FREEZE SETTINGS	27
12. CRITICAL INFORMATION	27
12.1 CHAMBERS 90% FULL ON INITIAL SET UP	27
12.2 LINE VOLTAGE DROP	27
12.3 LONG TUBING RUNS	27
13. TROUBLESHOOTING GUIDE	28
MECHANICAL	28
ELECTRICAL	30
ELECTRONIC CONTROLS	31
REFRIGERATION	32
DRINK QUALITY	34
LCD DISPLAY ERROR MESSAGES	35
LCD DISPLAY MESSAGES	39
LCD DISPLAY ERROR MESSAGES	40
WARNING LIGHTS STATUS	41
14. ILLUSTRATIONS, PARTS LISTINGS, AND DIAGRAMS	42
14.1 MOUNTING DIAGRAM - FBD562	42

TABLE OF CONTENTS (CONTINUED)

14.2 MOUNTING DIAGRAM - FBD563	43
14.3 MOUNTING DIAGRAM - FBD564	44
14.4 FLOW DIAGRAM/SCHEMATIC - FBD562	45
14.5 FLOW DIAGRAM/SCHEMATIC - FBD563	46
14.6 FLOW DIAGRAM/SCHEMATIC - FBD564	47
14.7 UPPER BOARD SCHEMATIC - FBD562	48
14.8 LOWER BOARD SCHEMATIC - FBD562	49
14.9 UPPER BOARD SCHEMATIC - FBD563	50
14.10 LOWER BOARD SCHEMATIC - FBD563	51
14.11 UPPER BOARD SCHEMATIC - FBD564.....	52
14.12 LOWER BOARD SCHEMATIC - FBD564.....	53
14.13 LOWER BOARD SCHEMATIC (INCLUDES AUXILIARY BOARD AND DIO BOARD) - FBD564	54

1. PREPARING THE LOCATION

1.1 LOCATION REQUIREMENTS

- The operational FBD56X countertop units range in weight from 345 pounds (156.5 kg) to 460 pounds (208.7 kg) and each unit requires a sturdy, level surface for placement (*see Safety Precautions, page 3*). When selecting a counter location, ensure the counter will support the unit weight plus the weight of any additional equipment placed near it.
- Adequate space above and behind a unit (See Figure 1.1) is required to allow:
 - Removal of side panels, if service is necessary.
 - Air circulation around vents on sides, back, and top of unit.
- A well-ventilated room is required with a temperature of 50°F to 90°F (10°C to 32.5°C). The environment, however, should be stable and not subject to abrupt changes in temperature.
- The unit should not be exposed to direct sunlight or chemicals.

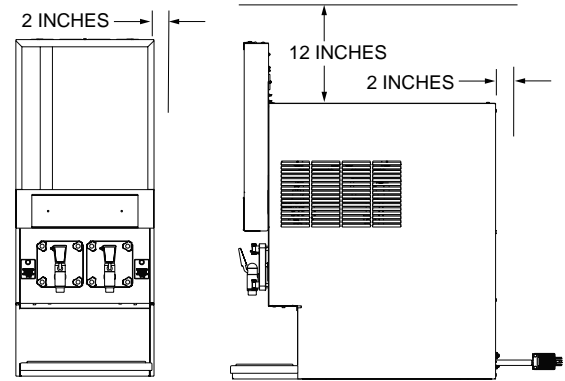

Figure 1.1
(FBD562 Unit Displayed)

1.2 ADDITIONAL REQUIREMENTS (TO BE PROVIDED BY THE CUSTOMER)

- CO₂ supply with a pressure of 70-72 psig (482.6 to 496.4 kPag). ***If a bulk CO₂ supply is used, the pressure should be set at 115 to 120 psig (792.9 to 827.4 kPag) and a secondary regulator installed at the unit to reduce the pressure to 70-72 psig.***
- Syrup supply - Bag-in-Box or five (5) gallon syrup tank (figal).
- Water supply with a minimum flowing pressure of 30 psig (206.8 kPag) and a maximum static pressure of 70 psig (482.6 kPag).

2. RECEIVING AND UNPACKING UNIT

2.1 RECEIVING

Each unit is tested and thoroughly inspected before shipment. At the time of shipment, the carrier accepts the unit and any claim for damages must be made with the carrier. Upon receiving the unit from the delivering carrier, carefully inspect carton for visible indication of damage. If damage exists, have carrier note same on bill of lading and file a claim with the carrier.

2.2 UNPACKING

- Cut banding from shipping carton and remove carton by lifting up. Remove protective side panels and four corner protectors.
- Remove drip tray assembly, accessory kit and manual from top packaging. Contact the dealer if any parts are missing or damaged.
- Remove side panels from unit.
- Inspect unit for concealed damage. If evident, immediately notify delivering carrier and file a claim against same.

- E. Lift unit up by the frame cross bracing and remove lower portion of carton.
- F. If unit is received with a shipping board attached to the bottom, remove shipping board from bottom of unit by accessing and removing the bolts located on the underside of the shipping board.

3. INSTALLING THE UNIT

There are several ways to install the unit. Follow the appropriate directions for the method you are using. Ensure that there is a minimum of twelve (12) inches (30.48 cm) open space ABOVE and two (2) inches (5.08 cm) open space on at least one side and BEHIND the unit (see Figure 1.1 above) for proper ventilation.

3.1 FLUSH MOUNTING

Flush mounting is when the unit is mounted on a countertop. Follow the following guidelines to ensure a proper installation.

- A. Be sure the counter will support the weight of the specific FBD unit being installed and the full length of the unit (including the drip tray). If permanently mounting the unit to a countertop, use the information in Section 15.1 or 15.2 to mark and drill the four (4) mounting holes in the countertop.
- B. Place unit on the counter using a lift (*see Safety Precautions, page 3*).
- C. If permanently mounting the unit to a countertop, install four (4) 3/8-16 UNC bolts (not included) through the underside of the counter [through the four (4) mounting holes drilled in the step just above], and into the frame.
- D. When the dispenser is to be permanently mounted to the counter top, seal dispenser base to counter top with a bead of clear silicone caulk or sealant which provides a smooth and easily cleaned bond to the counter.

3.2 ROLL AROUND CART

A roll around cart is used when a suitable countertop is not available and allows the unit to be moved for cleaning. These can be purchased from the dealer.

- A. Lock the wheels on the roll around cart.
- B. Place the unit on the cart (*see Safety Precautions, page 3*).
- C. Secure the unit to the cart by installing four (4) 3/8-16 UNC bolts (not included) through the cart mounting holes and into the frame of the unit.

4. CONNECTING TO ELECTRICAL POWER

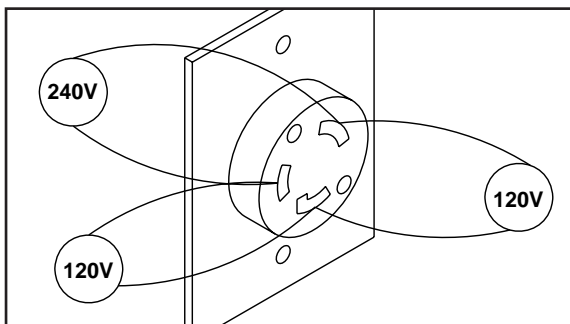

Figure 4.1

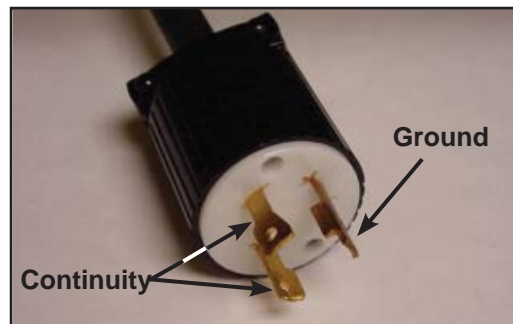

Figure 4.2

Use the following guidelines to connect electrical power to the machine for both 50 and 60 Hz service.

- A. The machine requires single phase 230VAC. *If line voltage is below 215VAC or above 245VAC, a 10% buck and boost transformer must be used. Operation below 215VAC or above 245VAC may damage the unit and cause inconsistent performance. **This also voids all warranties.***
- B. If connected to a “delta” three phase electrical system, use the two low voltage legs (check each leg to ground to insure the low voltage legs are used). **Using the high voltage leg will cause the machine to malfunction.** *In some locations, the power supply may have only one 230 volt hot leg. If so, ensure the hot leg goes to the L1 contactor in the electrical box.*
- C. This unit will not work properly if there is more than a 10V voltage drop in the power supply line between the power source and the machine. A drop of more than 10V indicates undersized wiring or excessively long runs.

- D. The unit must be installed on a “single branch” circuit (on a circuit by itself), installed as follows:
1. The **FBD564** Unit must be protected by 30 Amp service and a 30 Amp fuse (or circuit breaker). It is recommended that a 3 conductor, 30 Amp receptacle (NEMA #L630-R) be used. Using a voltmeter, check voltage across both “hot legs” (240VAC) and between ground and each “hot leg” (120VAC) to ensure proper wiring and voltage (see Figure 4.1).
 2. The **FBD562** and **FBD563** Units must be protected by 20 Amp service and a 20 Amp fuse (or circuit breaker). It is recommended that a 3 conductor, 20 Amp receptacle (NEMA #L620-R) be used. Using a voltmeter, check voltage across both “hot legs” (240VAC) and between ground and each “hot leg” (120VAC) to ensure proper wiring and voltage (see Figure 4.1).
- E. Remove the plug from the power cord and feed the cord through the strain relief located at the back of the unit. Tighten the strain relief securely. Reinstall the plug on the power cord and check for continuity on the plug across both “hot legs” and no continuity between each “hot leg” and ground (see Figure 4.2).
- F. **Do not connect the unit to power at this time.**

5. CONNECTING WATER, CO₂, AND SYRUP SUPPLIES (SEE FIGURES 5.1 THROUGH 5.5)

5.1 WATER SUPPLY

IMPORTANT

A WATER PUMP AND WATER REGULATOR ARE INSTALLED IN THE BASE OF THE MACHINE. A WATER FILTER SHOULD BE INSTALLED IN THE WATER LINE BEFORE BEING CONNECTED TO THE MACHINE. FLUSH THE FILTER WITH SEVERAL GALLONS (12-15 LITERS) OF WATER PRIOR TO USE TO INSURE BLACK CARBON “FINES” ARE NOT FED INTO THE FREEZING CHAMBER.

CAUTION:

THE BACKFLOW PREVENTION DEVICE (FBD PN 12-2272-0001) MUST HAVE A DRAIN LINE CONNECTED TO THE VENT (SEE FIGURE 5.1). THIS IS REQUIRED TO DRAIN AWAY WATER IN THE EVENT OF A BACKFLOW SITUATION OR A FAILURE OF THE BACKFLOW DEVICE. FAILURE TO DO SO MAY RESULT IN FLOODING OF THE ESTABLISHMENT.

NOTE:

Water pipe connections and fixtures directly connected to a potable water supply shall be sized, installed, and maintained in accordance with federal, state and local codes.

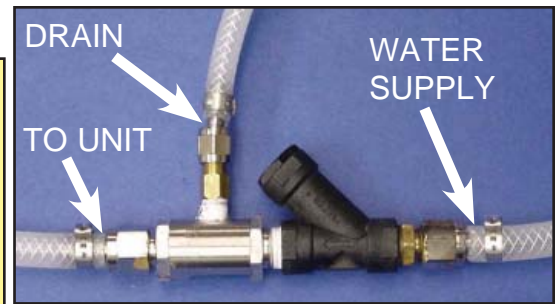

Backflow Prevention - Water Connections
Figure 5.1

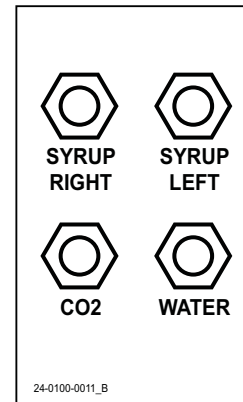

Bulkhead Fittings, FBD562
Figure 5.2

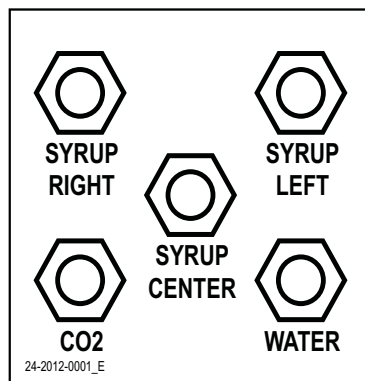

Bulkhead Fittings, FBD563
Figure 5.3

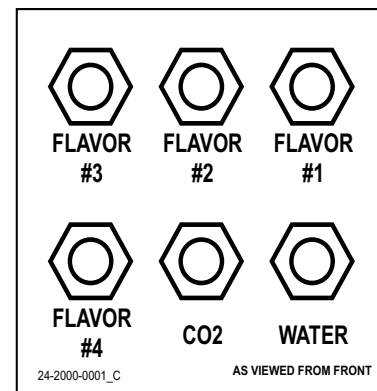

Bulkhead Fittings, FBD564
Figure 5.4

- A. Connect a backflow prevention assembly to the water inlet of the unit (see Figure 5.2). A backflow prevention assembly is available from FBD under PN 12-2272-0001.
- B. Fabricate a 3/8 inch supply line for connecting the unit to a potable water supply (a 3/8" barb by 1/4" flare nut fitting will be required).
- C. Install a shutoff valve in the water line as close to the unit as practical and convenient. *The use of a water filter is recommended.*
- D. Clear the line by running a minimum of two (2) gallons (7.57 liters) of water through the line before attaching the line to the unit.
- E. Connect the line to the bulkhead fitting labeled "WATER IN" located at the rear of the unit (see Figures 5.2, 5.3 or 5.4, as appropriate).
- F. For water cooled units:
 1. Fabricate another water line from the main water line and connect to the bulkhead fitting labeled "Condenser In" (a 3/8" barb by 3/8" flare nut fitting will be required) (see Figure 5.5).
 2. Fabricate a 3/8 inch drain line for connecting to the location labeled "Condenser Out" (a 3/8" barb by 3/8" flare nut fitting will be required) (see Figure 5.5).
- G. Route the drain line to a drain location.
- H. **Do not turn water on at this time.**

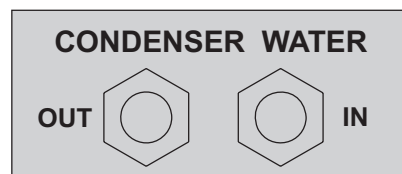

Bulkhead Fittings, Condenser
Figure 5.5

5.2 CO₂ SUPPLY

NOTE:

The CO₂ supply may come from either an independent tank/regulator or a bulk CO₂ system. If connected to a bulk CO₂ system, install a shutoff valve and a secondary supply regulator [to be set at 70-72 psig (482.6-496.4 kPag)] in the line. **Ensure that the CO₂ line comes directly from the main branch on the bulk supply and is not branched off down line. Failure to do so may starve the unit of CO₂ flow and cause performance problems.**

- A. Fabricate a 3/8 inch supply line for connecting the unit to a CO₂ supply.
- B. Connect the supply line to the CO₂ bulkhead fitting labeled "CO₂ IN" located at the rear of the unit (see Figure 5.2). A 3/8" barb by 1/4" flare nut fitting will be required to make connection.
- C. Splice a barb "cross" into the CO₂ supply line and run two (2) lines to the syrup pump CO₂ inlets.

Or

If Figal tank will be utilized, splice a barb "cross" into the CO₂ supply line and run two (2) lines to tank location and install CO₂ tank couplers to end of lines.

- D. **Do not turn on the CO₂ at this time.**

5.3 SYRUP SUPPLY

The unit may be connected to either a BIB (Bag-in-Box) or a five-gallon syrup supply (figal). Use the appropriate connection method below.

NOTE

Installations requiring long runs of tubing [25 feet or more (7.62 meters)] may encounter pressure fluctuation problems. The machine's sensors may indicate that the machine is out of syrup, water, or CO₂. To avoid pressure fluctuations, consider the following solutions.

- A. Increase the tubing size to 1/2 inch diameter.
- B. Install booster pumps in the supply lines. Use a vacuum regulating valve with syrup booster pumps.
- C. Increase primary CO₂ regulator pressure from bulk or tank CO₂ to 105 - 120 psig (723.9 to 827.4 kPag). A secondary regulator **will** be necessary for syrup pumps to avoid exceeding manufacturer's recommended operating pressures. Set the secondary regulator to 70-72 psig (482.6-496.4 kPag).

BIB SUPPLY

- A. Fabricate the appropriate number of 3/8 inch supply lines for connecting the unit to the syrup pumps.
- B. Connect the syrup lines to the bulkhead fittings as follows:
 1. For the **FBD562** Unit - to the appropriate bulkhead syrup fittings located at the rear of the unit (see Figure 5.2).
 2. For the **FBD563** Unit - to the appropriate bulkhead syrup fittings located at the rear of the unit (see Figure 5.3).
 3. For the **FBD564** Unit - to the appropriate bulkhead syrup fittings located at the rear of the unit (see Figure 5.4).
- C. **Do not turn on the CO₂ at this time.**

FIVE GALLON (FIGAL) TANK SUPPLY

- A. Fabricate the appropriate number of 3/8 inch supply lines for connecting the unit to the syrup tanks.
- B. Connect the syrup lines to the bulkhead fittings as follows:
 1. For the **FBD562** Unit - to bulkhead fittings labeled "SYRUP LEFT" and "SYRUP RIGHT" located at the rear of the unit (see Figure 5.2).
 2. For the **FBD563** Unit - to bulkhead fittings labeled "SYRUP LEFT", "SYRUP CENTER", and "SYRUP RIGHT" located at the rear of the unit (see Figure 5.3).
 3. For the **FBD564** Unit - to bulkhead fittings labeled "FLAVOR #1", "FLAVOR #2", "FLAVOR #3", and "FLAVOR #4" located at the rear of the unit (see Figure 5.4).
- C. **When using five gallon (figal) syrup tanks, a Syrup Restart Valve (SRV) and tank couplers must be used on each line. Warranties will be void if an SRV is not installed.**
 1. The "OUT OF" devices in the machine will not function properly without the use of a Syrup Restart Valve. If the "OUT OF" devices do not function, the machine will supply only water to the product cylinder and it will freeze up.
 2. When replacing a figal, insure that the syrup line to the dispenser is attached to the figal before the CO₂ line is attached to the figal. This will allow the SRV to work properly.
 3. To operate the SRV, press the restart button after syrup tank is changed. The red light beside each chamber will then go out and product will refreeze.
- D. **Do not turn on the CO₂ at this time.**

6. STARTING THE UNIT

6.1 INITIAL POWER-UP

- A. Insure the electrical power is disconnected from the unit.
- B. Using a Phillips head screwdriver, remove the stainless steel access panel located below the keypad (see Figure 6.1).
- C. Remove the splash plate and electric box cover (see Figure 6.2).
- D. Plug unit in to the electrical power. The graphics display should illuminate. Check for the display of information on the LCD control panel (this will read "COPYRIGHT" on bottom line of LCD display).
- E. With voltage meter, check voltage at contactor between L1 & L2 and record (see Figure 6.3 and the applicable Upper Board schematic in Section 14).
- F. Access the "Line Voltage" readout in the "SERVICE MENU\READOUTS\COMMON READOUTS" section of the LCD menu. **If the "Readout" voltage is more than two (2) volts different than the voltage across L1 and L2, the "Voltage Offset" must be changed.** Failure to do so will cause performance loss of the unit. To change the "voltage offset", go to "SERVICE MENU\MACHINE SETTINGS\COMMON SETTINGS" and enter the difference between the meter reading and the "Line Voltage" readout to make the LCD voltage reading match the L1 and L2 voltage. Reinstall the splash plate and electric box cover.



Typical Access Panel
Figure 6.1



Typical Electrical Box Cover
Figure 6.2

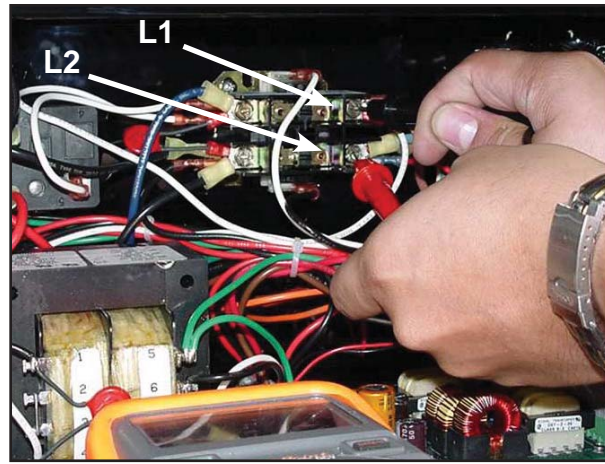

Figure 6.3

6.2 BRIXING

- A. With the unit powered up, press both of the “OFF” buttons on the display to ensure the unit is in the OFF state.

CAUTION

CHECK ALL SUPPLY LINES TO ENSURE THAT THEY ARE CONNECTED TO THE CORRECT FITTINGS. IF LINES ARE NOT CONNECTED PROPERLY, COMPONENTS WILL BE DAMAGED.

- B. Open the water supply valve and check all water line connections for leaks.
 C. Connect the BIB connectors, or the syrup and CO₂ couplers, to figal tanks. Check all syrup supply connections at the rear of the machine for leaks.
 D. Open the CO₂ tank valve and adjust the primary tank regulator until the “CO₂ Pressure” readout in the “SERVICE MENU\ READOUTS\ COMMON READOUTS” reads 70-72 psig (482.6 kPag to 496.4 kPag). Check all CO₂ line connections for leaks.
 E. Adjust the CO₂ secondary regulator (located inside the machine) to read 28-32 psig (193.1 to 220.6 kPag) according to the LCD readout found in the “REGULATED CO₂” readout in the “SERVICE MENU\ READOUTS\ COMMON READOUTS” section of the LCD menu.

NOTE

For low carbonation applications, see Quick Reference Sheet on page 4 for settings information.

IMPORTANT!

SET ALL PRESSURES USING THE LCD READOUTS ON THE UNIT - NOT BY THE GAUGES ON THE REGULATORS!

- F. Close Syrup flow controls by backing (turning counter-clockwise) the Right adjustment screw all the way out (see Figure 6.4).
 G. Open the sample valve and check the water flow rate and set to provide a flow of 15 ounces in 10 seconds using a graduated container. Do this for every solution module. Turn the Left adjustment screw *clockwise to increase flow or counter-clock-wise to decrease flow*.
 H. Pre-set Syrup flow by turning Syrup flow controls in three (3) turns (turning clockwise).
 I. Place a container under the sample tube and turn the sample valve until a good water and syrup mixture is obtained (see Figure 6.4). ***This sample should be discarded.***
 J. Place a sixteen (16) ounce (0.473 l) cup under sample tube and open the sample valve ***until 9 - 12 ounces (0.266 - 0.355 liter) have been dispensed into cup.***

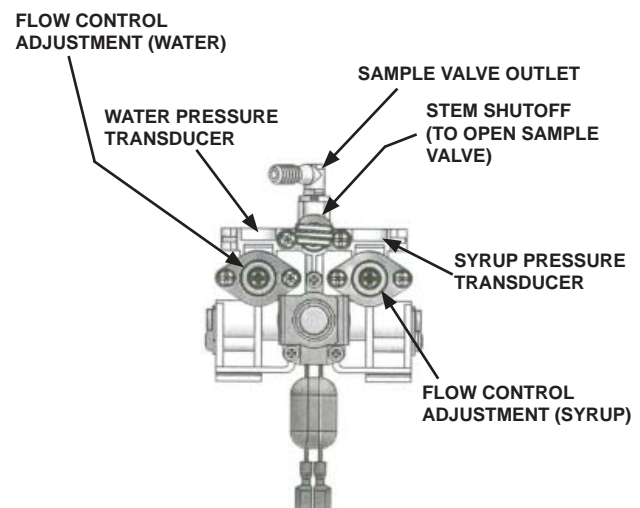

Figure 6.4

- K. Measure the brix with a refractometer. Set brix to between 13.5 and 15.0 by adjusting the syrup brix flow controller *clockwise to increase brix level or counter-clockwise to decrease brix level. If the brix requires adjustment, discard a sample before checking the brix again.*

NOTE

Do not adjust the brix with the water flow control setting unless you are unable to obtain the desired brix with adjustments to the syrup flow control.

Brix reading is affected by temperature. Samples taken from the chamber should be at the same temperature as from the sample valve.

- L. Repeat steps I, J, and K for other chambers.

6.3 FILLING THE CHAMBER

- A. Access “CO₂ SOL” by going to the “SERVICE MENU\MANUAL ON/OFF” section of the service menu.
- B. Displace the air in the chamber with CO₂ by activating the CO₂ solenoid.
1. Pull and hold the relief ring until the escaping, rushing air sound almost stops; then release the ring. Allow the pressure to rebuild in the tank.
 2. Repeat this procedure at least two more times until the air has been displaced by the CO₂. ***Remember to deactivate the CO₂ solenoid upon completion.***
- C. Repeat steps A and B above for the other chambers. ***Remember to deactivate the CO₂ solenoid upon completion.***
- D. With CO₂ in the chamber, press a “FILL” button to begin filling the chamber with product. If the chamber does not fill, gently pull the Relief Ring until filling begins and then release. As the chamber fills, the pressure in the chamber will increase until it rises above the psi fill point. At this point, the chamber will stop filling and the LCD will readout “Fill Hold”. It will then be necessary to pull the relief ring to relieve the pressure and allow filling to continue. Slowly pull the relief ring until the pumps activate, then release. Repeat the venting process **until the chamber is 90% full (level with relief valve), then press Fill button to turn OFF. Fill one (1) chamber at a time.**
- E. Repeat steps A, B, C, and D for the remaining chambers.
- F. Press the “DEFROST” and then the “RUN” buttons on both sides of the control panel to begin the freezing process. The beater motors will begin to run but the compressor ***will wait for two (2) minutes before starting.*** After the two (2) minute waiting period, the machine will defrost and then begin the freeze cycle.
- G. After an initial freeze down, the product will be frozen and ready to dispense.

NOTE

On an initial freeze down, products must be given adequate time to absorb CO₂. Until CO₂ is properly and adequately absorbed, drinks could be too “wet” or too “heavy”. If adjustments are necessary, refer to section 9.

- H. Re-check CO₂, Water, and Syrup lines for leaks.

CRITICAL REGULATOR AND FLOW CONTROL SETTINGS	
SET ALL PRESSURES USING THE LCD READOUTS ON THE UNIT - NOT BY THE GAUGES ON THE REGULATORS!	
CO₂ PRIMARY REGULATOR	The CO ₂ Primary Regulator <u>MUST BE SET TO 70-72 psig (482.6 TO 496.4 kPag).</u>
CO₂ SECONDARY REGULATOR	The CO ₂ Secondary Regulator <u>SHOULD BE SET AT 28-32 psig (Secondary Regulator) (193.1 TO 220.6 kPag) STATIC PRESSURE.</u> For low carbonation applications, see Quick Reference Sheet on page 4 for settings information. The CO ₂ Secondary Regulator is on the header assembly which is behind the access panel. This regulator is a “non-vent” regulator. This means that if you lower the regulator setting, you will need to dispense drinks (with “Fill” activated) until cylinder begins to refill before the new setting will register on the gauge.
FLOW CONTROLLERS	WATER FLOW MUST BE SET TO PROVIDE A FLOW OF 15 OUNCES IN 10 SECONDS BEFORE ADJUSTING THE BRIX. <u>BRIX MUST BE SET BETWEEN 13.5 - 15.</u> Flow controllers are on the header assembly. A sample may be taken by fully opening the sample valve, by turning it clockwise until it stops.

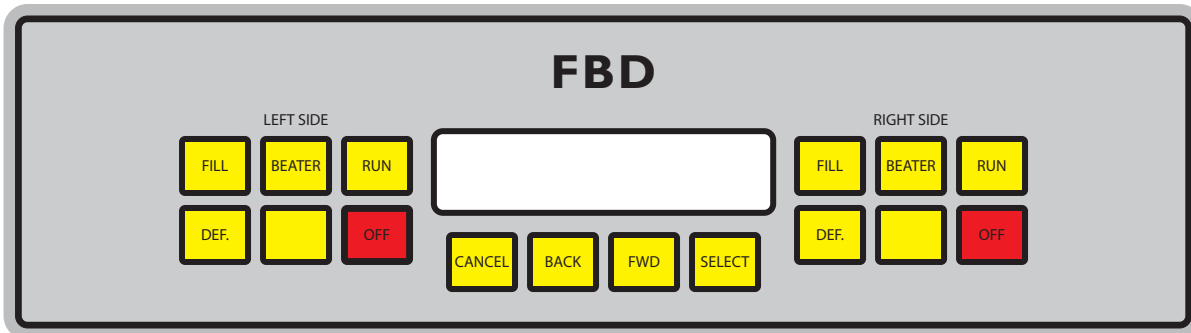

FBD562 Contols
Figure 7.1a

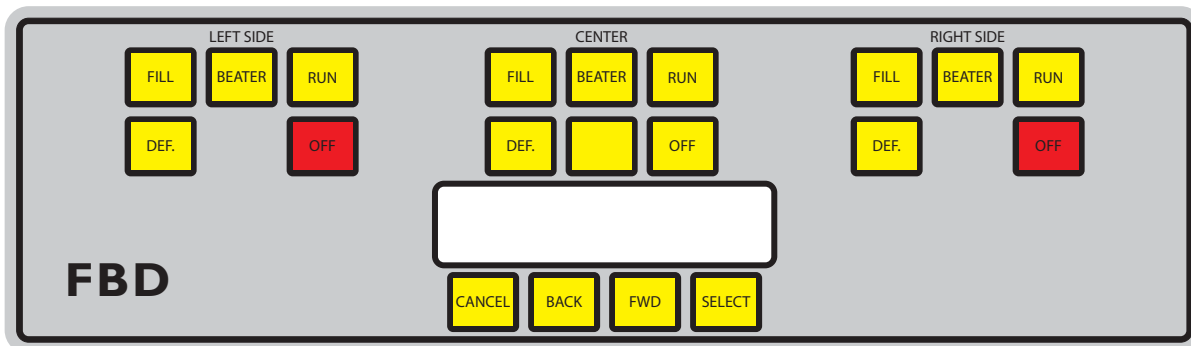

FBD563 Contols
Figure 7.1b

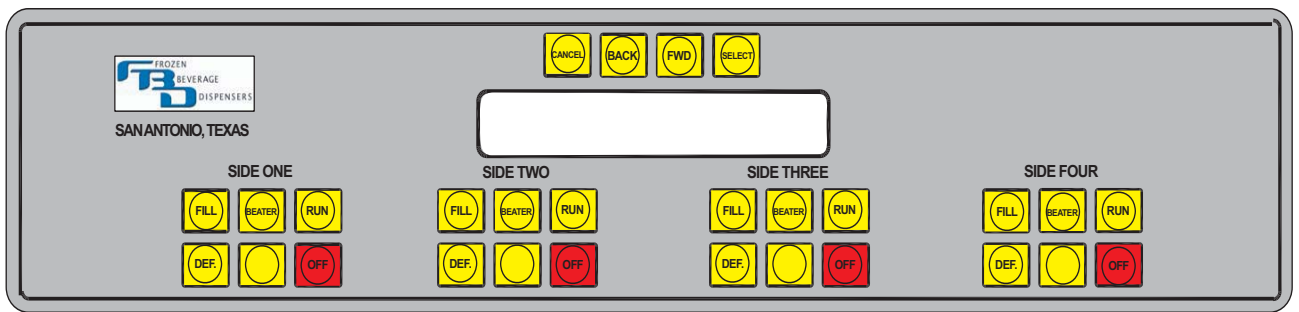

FBD564 Contols
Figure 7.1c

7. OPERATION OF THE DISPENSER

7.1 OPERATING ELECTRONIC CONTROLS

- A. The electronic machine controls are designed to provide a logical sequence of operation with a minimum of written instruction. System operating parameters are selected and set from a menu.
- B. Buttons (see Figures 7.1a, 7.1b and 7.1c).
 1. Each chamber has five (5) active buttons. They are labeled FILL, BEATER, RUN, DEF (defrost), and OFF.
 2. **Each button operates a double acting switch.** Pressing the button once activates the process. Pressing the button a second time deactivates the process. *Take care not to double press the buttons when first activating a process.*

RUN The RUN button initiates the freeze process. After pressing this button, the beater motors will run for five (5) seconds before the compressor starts. Run also maintains the flow of product into the chambers when needed. You should always press the DEFROST button first to baseline the unit.

OFF The OFF button turns off all the machine's refrigeration and chamber refill systems. All of the electronic controls are still active.

BEATER The BEATER button activates the beaters inside the freezing chambers. The beaters can be activated to mix the slurry.

NOTE:

The beaters start automatically when the RUN or DEF buttons are pressed.

DEF The DEF button allows the user to manually defrost chamber. Because the unit automatically defrosts during the day, it is not necessary to defrost manually. However, this button provides the option to do so if desired.

FILL The FILL button activates the solenoid valves that allow product to flow into the freezing chambers (providing the pressure in the barrel is low enough to allow a fill). Each chamber should be filled to 90% of chamber capacity (level with the relief vent valves) prior to start-up.

C. Common Controls and Displays

1. The four (4) control buttons, located below the LCD display, allow access to the various menu levels for the machine (see Figures 7.1a, 7.1b and 7.1c)

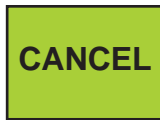

The CANCEL button cancels any current operation and steps the operator *back* one (1) level in the menu.



The BACK button steps the operator backwards within the current level. This button also allows the operator to decrease or lower values (numbers).



The FWD button steps the operator forward within the current level. This button also allows the operator to increase or raise values.



The SELECT button allows the operator to enter changes in the unit programming and it also allows the operator to move into different levels in the menu.

2. The LCD display screen in the center of the control panel allows the operator access to unit status, settings, and operational information (see Figures 7.2a, 7.2b and 7.2c). The screen is divided into an upper and lower section. The upper section of the screen will show the current status of each chamber. The lower half of the screen displays a mode that can be changed or monitored.

D. Explanation of the Menu Structure (See Figure 7.3)

1. *Access to the control panel is separated into two (2) levels. These levels have been established to make certain information available to the operators and other information available to service personnel.*

Level One This **CUSTOMER MENU** level is designed for the machine operator at the store level. *The store operator should **only** access this level of information, and should **NOT** access or make changes in the **SERVICE MENU** without prior authorization and approval.*

Level Two *The **SERVICE MENU** has been established for the use of authorized service technicians **ONLY**. This level provides access to all setup values that will optimize the operation of the machine. Incorrect settings at this level could prevent the machine from operating properly or cause damage to the unit. Included in this level are various accumulated totals and diagnostic tools that help the technician evaluate problems.*

NOTE

To access the Service Menu, press the FWD button on the control panel until "SERVICE MENU" displays. Press the unmarked button on the Left side of the panel (center blank button for the 563). The service menu has been accessed when "MACHINE SETTINGS" displays. Press FWD to access other options.

E. How to Access and Change Values

The same procedure for changing values applies to all access levels. The following steps allow the parameters of the control system to be monitored and changed.

1. The current mode is displayed in the lower half of the LCD. Press the FWD button to step to the next mode. Continue pressing the FWD or BACK button until the desired mode is displayed. When the desired mode is displayed, press SELECT to enter the mode.
2. To make changes to the displayed mode, press the SELECT button. When a value in the lower half of the display begins to flash, this indicates that the value can be changed.

- To change the value, press the FWD button to increase the value or the BACK button to decrease the value. Any on/off functions can be changed by pressing the SELECT button.
- Once the desired value is displayed, press the SELECT button to enter the value into the computer. Pressing the SELECT button will stop the display from flashing. When the value stops flashing, it has been changed.

NOTE:
 When entering TIME, WAKE, or SLEEP functions, both the hours and minutes must be selected before the computer will accept the change. For the Defrost Times, days in upper case (capitals) are selected. Days in lower case are NOT selected.

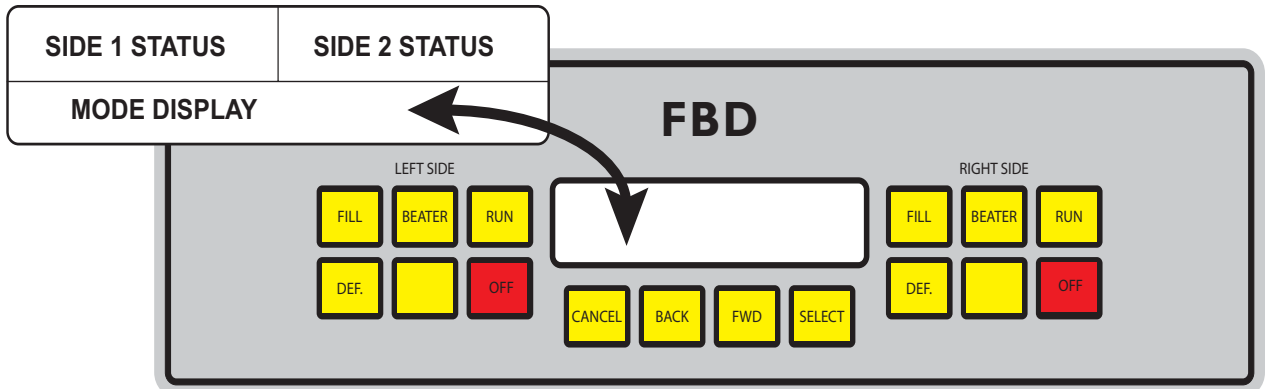

FBD562, Access and Change
 Figure 7.2a

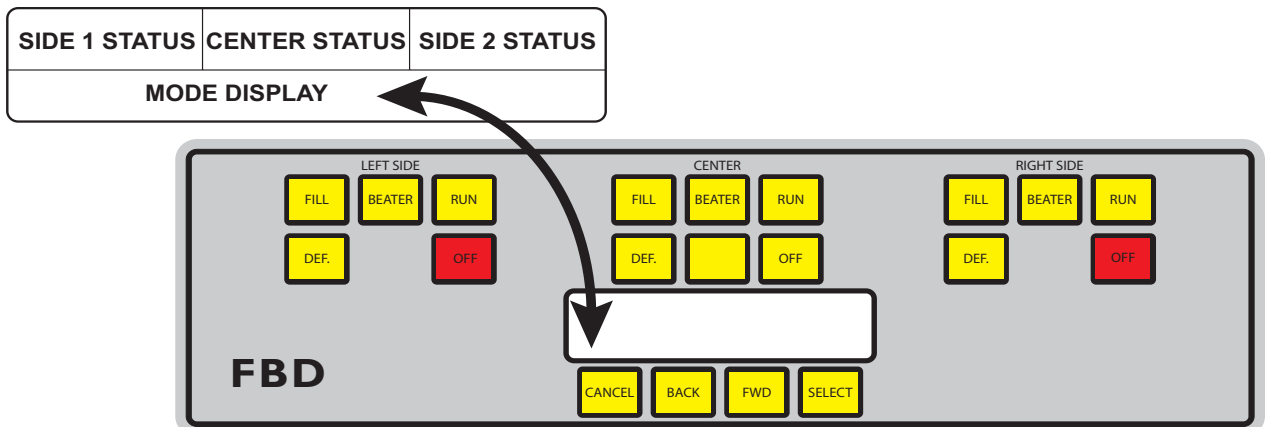

FBD563, Access and Change
 Figure 7.2b

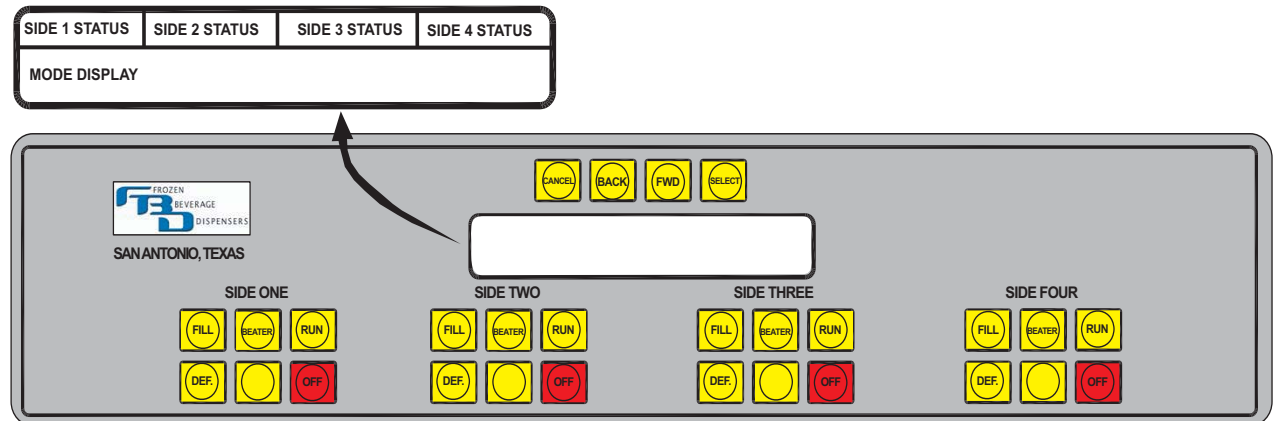

FBD564, Access and Change
 Figure 7.2c

56X SERIES MENU STRUCTURE

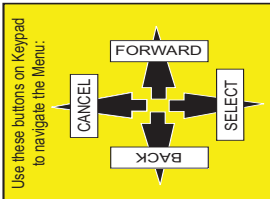
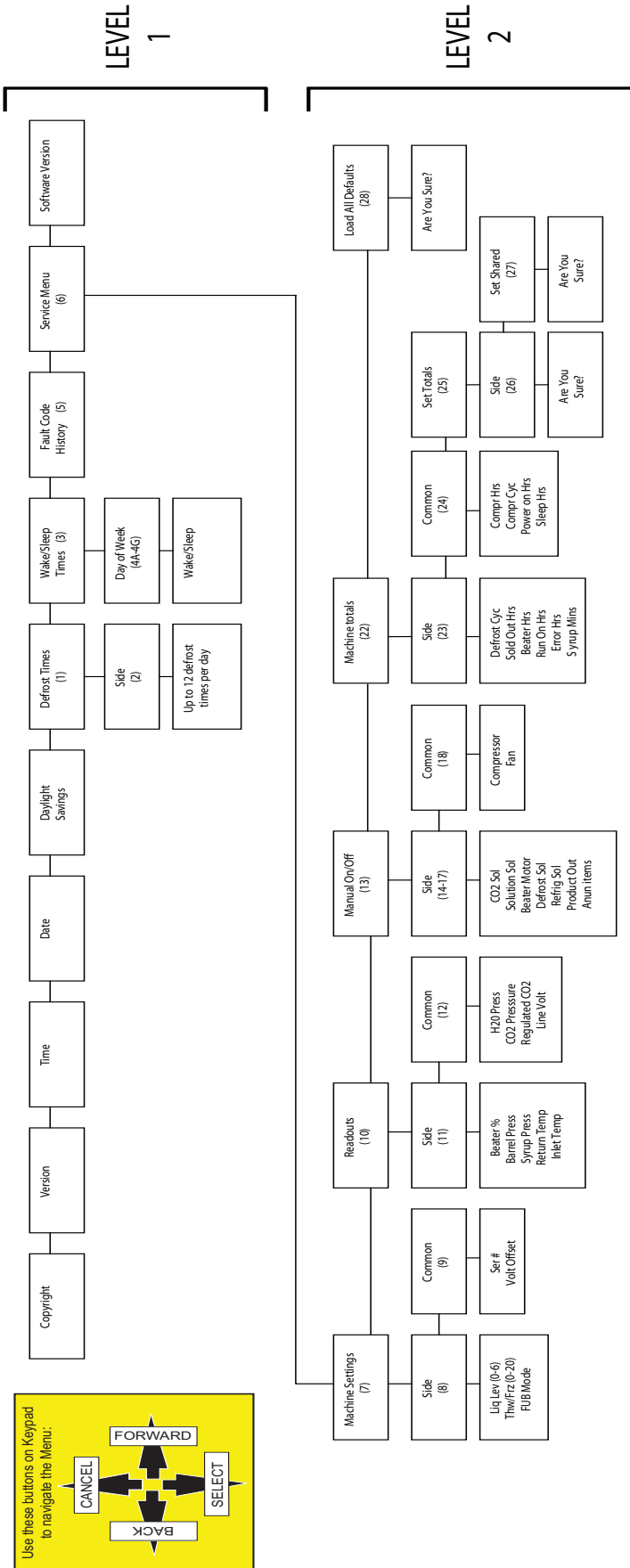

FBD56X Series, Menu Structure
Figure 7.3

7.2 MACHINE ACCESS (SEE FIGURES 7.2.A, 7.2.B AND 7.2.C)

A. Machine Operator Display

Mode Display	Description	Preset Value
1. VERSION	Shows current version of the software installed.	
2. TIME	Used to set the time of day. The machine uses a 24 hour format (military time) clock. The clock has a battery backup which maintains correct time even if not plugged into electrical power.	
3. DATE	Used to set the date and day of the week.	mmm-dd dow
4. DAYLIGHT SAVING	Sets Daylight Saving Time (DST) option. ON for use of DST; OFF for use of Standard time.	
5. DEFROST TIMES	Each side can defrost itself up to 12 times a day. Set the defrost times so the machine does not defrost during periods of high demand. Low demand, every 3 hours. High demand, every 4-5 hours. Offset Left Side and Right Side defrost times by 60 minutes.	4 hours
6. WAKE/SLEEP TIME	Sets the machine wake and sleep times. <u>To manually wake-up and operate the unit, press DEFROST, then RUN.</u>	00:00
7. FAULT CODE HISTORY	This feature stores the last 10 error codes and helps the service agent to readily diagnose a problem. The readout is formatted as shown in the two examples below. <div style="margin-left: 40px;"> 0 : Out of syrup (first error is an out of syrup error) 0S:04/03/00 12:31:05 (error started at 12:31 PM on 4/3/00) 0E:04/03/00 13:33:56 (error ended at 1:33 PM on 4/3/00) 1 : Out of CO₂ (second error is an out of CO₂ error) 1S:04/07/00 15:03:55 (error started at 3:03 PM on 4/7/00) 1E:04/08/00 10:26:01 (error ended at 10:26 AM on 4/8/00) </div> The same format continues on for errors 2 through 9.	
8. SERVICE MENU	Authorized technician access.	N/A
Service Note: Press “DEF” and then “RUN” on the control panel to start a machine that has been turned off manually. This allows the machine to automatically reset the baseline.		

7.3 MACHINE SETTINGS

These settings are preset by the machine. **DO NOT change unless there is a problem with drink quality.**

Mode		
1 Side Settings 2 Side Settings 3 Side Settings 4 Side Settings	Level Control = 3 Thaw/Freeze = 10 FUB MODE = OFF	The higher the value, the less expansion in the drink. The lower the value, the greater the expansion in the drink. The lower the value, the harder and colder the drink. The higher the value, the higher the drink temperature. The lower the value, the lower the drink temperature. For more frozen, use lower values. For more liquid or less frozen, use higher values. Test for proper drink temperature (24°F to 28°F) before adjusting. This will allow customer to use a FUB product and not inject CO2 into product. Default setting is "OFF". Select "ON" to initiate the mode.
Common Settings	Serial # Voltage Offset = 0	Default setting is 999999. Serial number of the unit will be placed inside menu if Bevtrak is to be used on the unit. Use this offset to match the "Line Voltage" readout (in "Common Readouts") to the actual incoming voltage measured with a voltmeter at L1 and L2 of the contactor (see Section 6.1 and Figure 6.3).
<p align="center"><i>This must be completed prior to starting machine for operation.</i></p> <ol style="list-style-type: none"> Measure, with a voltmeter, incoming line voltage at L1 and L2 of contactor and record. Read LCD "Line Voltage" reading under READOUTS - Common Readouts and compare with voltmeter reading. [If within two (2) volts, skip Steps 3 and 4.] Using Voltage Offset, enter value that will allow LCD Line Voltage readout to match the voltmeter reading. Once this is set, the machine is ready to run. 		
<p align="center"><u>NOTE:</u></p> <p>In the FBD562 unit, the 1 Side and 2 Side equate respectively to the Left Side and Right Side; and in the FBD563 unit, the 1 Side, 2 Side, and 3 Side equate respectively to the Left Side, Center, and Right Side. In the FBD564 unit, the 1,2, 3 and 4 sides are from left to right. (See Figures 7.1.a and 7.1.b and 7.1.c.)</p>		

7.4. Readouts

For information and diagnostics.

Mode		
1 Side Readouts 2 Side Readouts 3 Side Readouts 4 Side Readouts	Allows user to view information about each side individually.	Beater % = This percentage represents frozen and thaw status. Tank Pressure = This represents current pressure in the chamber (tank). Syrup Pressure = This represents current pressure of the syrup at the header. Return Temp. = This represents the current temperature of the return refrigerant line to the compressor. Inlet Temp. = This represents the current temperature of the refrigerant line entering the cold pac.
Common Readouts	Allows user to view information common to both sides.	H ₂ O Pressure = This represents the current incoming water pressure. CO ₂ Pressure = This represents the current incoming CO ₂ pressure. Regulated CO ₂ = This represents the current internally REGULATED CO ₂ as set by the secondary CO ₂ regulator. Line Voltage = This represents the current incoming line voltage.
<u>NOTE:</u> In the FBD562 unit, the 1 Side and 2 Side equate respectively to the Left Side and Right Side; and in the FBD563 unit, the 1 Side, 2 Side, and 3 Side equate respectively to the Left Side, Center, and Right Side. In the FBD564 unit, the 1,2, 3 and 4 sides are from left to right. (See Figures 7.1.a and 7.1.b and 7.1.c.)		

8. CLEANING AND SANITIZING THE UNIT

8.1 GENERAL INFORMATION

NOTE

The following cleaning and sanitizing procedures pertain to the FBD equipment identified by this manual. *If other equipment is being cleaned, follow the guidelines established for that equipment.*

- A. FBD equipment (new or reconditioned) is shipped from the factory, cleaned and sanitized in accordance with NSF guidelines. After installation is complete, the operator of the equipment must provide continuous maintenance as required by this manual and/or state and local health department guidelines to ensure proper operation and sanitation requirements are maintained.
- B. Cleaning and sanitizing should be accomplished only by trained personnel. Sanitary gloves are to be used during cleaning and sanitizing operations. Applicable safety precautions must be observed. Instruction warnings on the product being used must be followed.

- C. Water lines are **NOT** to be disconnected during the cleaning and sanitizing of syrup lines to avoid contamination.
- D. Do **NOT** use strong bleaches or detergents. They tend to discolor and corrode various materials.
- E. Do **NOT** use metal scrapers, sharp objects, steel wool, scouring pads, abrasives, solvents, etc., on the dispenser.
- F. Do **NOT** use hot water above 140°F (60°C). This may damage certain materials.

8.2 REQUIRED CLEANING EQUIPMENT

- A. A mild soap solution (for example, Ivory Liquid, Calgon, etc.) mixed with clean, potable water at a temperature of 90 to 110°F (32 to 44°C) should be used to clean the external components of the equipment. Any equivalent mild soap solution may be used as long as it provides a caustic based, non-perfumed, easily rinsed mixture containing at least two (2) percent sodium hydroxide (NaOH). Rinsing must be thorough and use clean, potable water which is also at a temperature of 90 to 110°F (32 to 44°C).
- B. Sanitizing solutions should be prepared in accordance with the manufacturer's written recommendations and safety guidelines. Any sanitizing solution may be used as long as it is prepared in accordance with the manufacturer's written recommendations and safety guidelines, and provides 200 parts per million (PPM) available chlorine. Sanitizing solution is to be purged from line(s) and equipment by flushing with product only until there is no after taste. **Do not rinse with water.**

NOTE

Please note that a fresh water rinse cannot follow sanitization of equipment. Purge only with the end use product until there is no after taste in the product. **This is an NSF requirement.**

8.3 DAILY CLEANING OF THE UNIT

CAUTION

DO NOT USE ABRASIVE TYPE CLEANERS.

- A. On a daily basis, or more often if necessary, wash all exterior surfaces of unit with a mild soap solution. Rinse with clean water. Wipe dry with a clean soft cloth.
- B. Remove and wash drip tray in mild soap solution. Rinse with clean water. Reinstall drip tray on unit.

8.4 SANITIZING THE SYRUP SYSTEMS

The 56X units should be sanitized annually during a regularly scheduled Preventive Maintenance Program as recommended by FBD. Follow the sanitizer manufacturer's recommendation in preparing the sanitizing solution. The following procedure takes about one (1) hour.

- A. Press the "OFF" button followed by the "DEF" button for both chambers.
- B. After defrost, activate the CO₂ solenoids by going to the "SERVICE MENU\MANUAL ON/OFF" section of the service menu.
- C. Place a container under the valve and empty the barrels. Activate the beaters to facilitate removal of product.
- D. Turn off the CO₂ solenoids and beaters after the barrels are empty.
- E. Prepare five (5) gallons of sanitizing solution following manufacturer's directions. The water temperature should be 110 to 115°F (44 to 46°C). **Stir the solution until sanitizing agent has completely dissolved.**
- F. Disconnect all BIB connectors from syrup boxes, then install BIB Adapters (FBD PN 05-0249) onto BIB connectors.
- G. Turn off the water at source.
- H. Place a container under the sample valve tube and open the sample valve tube to purge syrup and water from lines. When the Tygon BIB tubing is clear of syrup, lower sanitizing adapters into sanitizing solution. Continue purging lines until any foam in the line clears.
- I. Activate the solution solenoids at the "SERVICE MENU\MANUAL ON/OFF" section of the service menu.
- J. Fill each chamber approximately **2/3 full** with sanitizing solution/water mixture then deactivate the solution solenoids.
- K. Activate the CO₂ solenoids to evacuate the solution from the chambers. Once the chambers are evacuated, deactivate the CO₂ solenoids and **purge pressure from cylinders by pulling faceplate relief valve.**

- L. Again, activate the solution solenoid and allow the chamber to fill **1/2 full** of sanitizing solution. Deactivate the solution solenoid and turn on beaters. Let solution agitate for **three (3) minutes**.
- M. Activate the CO₂ solenoids and evacuate the sanitizing solution from chamber. Then turn off beater, deactivate the CO₂ solenoids and purge pressure from chamber.
- N. Remove sanitizing adapters from the BIB lines and reconnect the lines to the syrup supplies.
- O. Turn on water at source.
- P. Partially refill the chambers (1/3 full) with syrup and water by activating the solution solenoids. Turn off the solenoids. Run the beaters for a few seconds.
- Q. Drain the product by activating the CO₂ solenoids.
- R. Partially refill the chamber again and test the product for off taste. Repeat the drain/fill process until no off taste exists.
- S. When there is no more off taste, fill the unit following the procedure outlined in Section 6.3.

8.5 PREVENTIVE MAINTENANCE

An annual Preventive Maintenance schedule is recommended by FBD and should include the following steps.

- A. Clean Air Filter – refer to Section 8.6.
- B. Check Brix – refer to Section 6.2.
- C. Replace rear seals (seals are replaced from the front and do not require removal of the beater motor).
- D. Inspect and replace scraper blades if necessary.
- E. Sanitize according to manufacturer’s recommended procedure in Section 8.4.
- F. Check all fittings and components for leaks. Repair if necessary.
- G. Verify Time, Date, Sleep, and Defrost settings. Adjust as necessary.

NOTE:

Refer to the 56X Series Training Seminar for detailed Preventive Maintenance instructions and checklist.

8.6 CLEANING THE AIR FILTER

The air filter should be cleaned every 90 days, or more frequently as required by the installation environment. A dirty air filter can reduce performance of the machine.

- A. Open merchandiser.
- B. If the filter protrudes from a slot in the front cover, remove the filter by grasping the edge and sliding it out. If there is not a slot in the front cover, remove the cover by first removing the screws and then with the cover removed, use the same procedure listed above to remove the filter.
- C. Wash filter with clean water, shake off excess.
- D. Allow filter to dry.
- E. Reinstall filter and front cover as necessary.
- F. Close merchandiser.

9. BASICS OF OPERATION

NOTE

On an initial freeze down, products must be given adequate time to stabilize. Making adjustments too quickly may negatively affect drink quality.

9.1 MAKING ADJUSTMENTS TO THE FBD56X SERIES UNITS

- A. In order to produce a consistent, quality beverage with the FBD56X Series Frozen Beverage Dispensers, there are a few critical settings that must be maintained. These settings are preset when you receive the machine from the factory, but, due to variations that occur (e.g., in operating environments, syrups, and individual machines, etc.), it may be necessary to make minor adjustments to these critical settings. Adjustments are easily made using the keypad located behind the door at the front of the machine, or by adjusting the CO₂ regulator located behind the access panel below the keypad.
- B. *The settings that control product quality and production rate are:*
 - 1. **Beverage Syrup Content or Brix Level (Set on Syrup Flow Control)**
 - 2. **Chamber “Level Control”**
 - 3. **Regulated CO₂ Injection Pressure**
 - 4. **Freeze and Thaw Settings**

C. In Sections 4 through 7 of this manual are instructions on machine installation and initial operation. These instructions should be followed for initial setup of the machine. If the product quality is not as desired after allowing time for stabilization, the critical settings should be checked and adjusted as necessary. *The following sections discuss the sequence and method to verify these settings. **These four (4) critical settings are explained here to help better your understanding of how the machine operates so you can make adjustments, if necessary.***

1. Adjusting the Brix Level

- a. Consistent, high quality beverages require adjusting and maintaining the syrup content of the drink or brix level between 13.5 and 15. A brix level lower than 13.0 may cause operational problems. A low brix level (lower than 13.0) will produce a weak tasting drink and tends to freeze product around the beater shaft. A high brix level (higher than 15.0) causes freezedown times to be longer and produces a more liquid drink. *Water flow rate must be set to provide a flow of 15 ounces in 10 seconds prior to adjusting brix.*

2. "Level Control"

- a. The FBD56X Series frozen beverage dispenser utilizes a proprietary liquid level control system (patented) to hold a constant liquid level. A constant liquid level assures a quality frozen product.
- b. If a more "wet" product is desired, the numerical setting (0-6) should be increased. If a "drier" and colder product is desired, the numerical setting should be decreased.
- c. The default value set at the factory is 3. This setting should produce an excellent quality product. (See Section 10 for instructions on changing settings.)

3. Regulated CO₂ Injection Pressure

The CO₂ injection pressure is set by adjusting the secondary regulator, located behind the access panel below the control panel in the front of the machine. The CO₂ regulator should be set at 28-32 psig (193.1 to 220.6 kPag). The unit then automatically sets the chamber pressure between 25 and 30 psig (172.4 and 206.8 kPag).

NOTE

Some "cola syrups" have been shown to produce a better quality drink with a lower chamber pressure. However, lowering the "Regulated CO₂ regulator" will affect all chambers. For adjusting individual chamber pressures, refer to Section 10.

4. Thaw and Freeze Settings

- a. The Thaw and Freeze settings signal the refrigeration system when to start freezing and when to stop freezing. The liquid in the chamber freezes until it reaches the desired frozen consistency; then the refrigeration system shuts off and the chamber begins to thaw. The liquid continues to thaw until it reaches a consistency specified by the Thaw value. The Thaw value is the point at which the refrigeration system turns back on and refreezes the product. This assures the product is maintained in a good acceptable quality frozen drink range.
- b. Prior to changing any Thaw or Freeze settings, make sure the brix and water flow rate are correct and the liquid level control settings are properly set. Also assure the chambers stay filled to the proper levels with the proper amount of CO₂. **The optimum frozen drink temperature is 24 to 28°F (-4.4 to -2.2°C) and should be checked prior to making any adjustments.** (See Section 10 for instructions on changing settings.)

CAUTION

IF THE THAW - FREEZE IS SET AT A LOWER SETTING, COMPRESSOR "SHORT CYCLE" CAN OCCUR THAT WILL CAUSE THE COMPRESSOR TO OVERHEAT. IF A LOWER SETTING IS USED, THE *DISPENSER OPERATION MUST BE MONITORED* TO INSURE THE COMPRESSOR DOES NOT "SHORT CYCLE".

- c. The Thaw and Freeze settings may be raised or lowered to change the temperature of the product. A default setting of 10 is set at the factory. To decrease the temperature, decrease the numerical setting; to increase the temperature, increase the numerical setting.

10. CHANGING FACTORY SET “LEVEL CONTROL”

NOTE

Always check brix and water flow rates before adjusting “Level Control.”

The factory setting of the liquid “Level Control” may be changed to alter the consistency of the product. Adjusting the liquid “Level Control” will change a drink that is too liquid or one that is frozen too hard. A product that is frozen too hard will not allow the chamber to stay full and the drink will dispense with sudden releases of CO₂ (“spitting”). A “too full” chamber may cause a “too wet” drink.

10.1 BEFORE CHANGING “LEVEL CONTROL” SETTINGS

- A. Each machine ships with preset level control values. These values should be correct for normal operation of the machine and should not have to be modified.
- B. **Before making any changes to the level control settings, defrost both chambers by pressing the “DEF” buttons located on the control panel. The machine may automatically correct any problems with drink quality after going through a defrost cycle.**
- C. After the defrost cycle, the compressor may cycle on and off several times to ensure that the product is uniformly frozen. *Wait several minutes before judging the quality of the product.*
- D. If factory level control settings are correct, the product should freeze, thaw and then refreeze to an acceptable consistency range. *Remember, drinks poured directly after a freeze cycle will appear more frozen than the last drink poured before the unit begins to refreeze the cylinder.*
- E. The level control settings of each drink chamber are preset to a default value of 3. If the secondary regulator inside the unit is properly set to 28-32 psig (193.1 to 220.6 kPag), the chamber pressure will be “set” automatically. For low carbonation applications, set CO₂ secondary regulator to read 17-19 psig (117.2-131.0 kPag).
- F. After the machine is installed and each chamber is properly filled, press the “DEF” button to allow the machine to automatically “baseline”. Baseline indicates to the machine that the chamber contains liquid. As a result, the machine sensors determine how much to freeze the product.
- G. The display will flash “DEFROSTING” until baselining is complete. The machine will automatically start running if the machine was running when the defrost cycle was started. If the machine was not running before the defrost cycle started, the “RUN” button must be pressed.

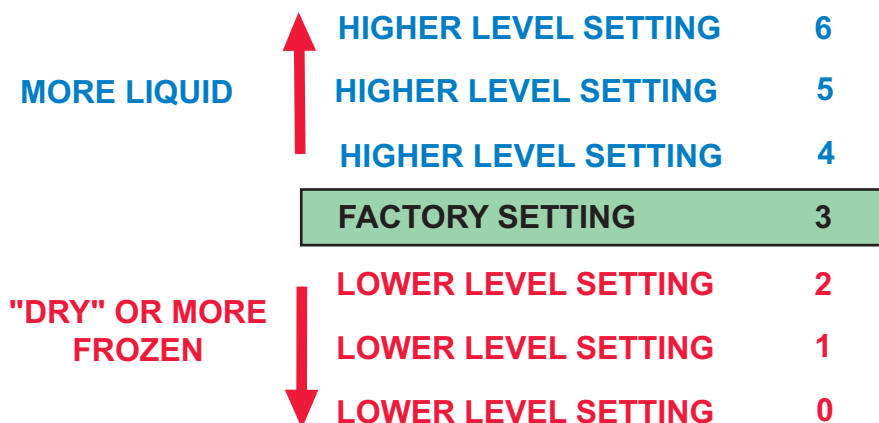

Recommended “Level Control” Settings

Figure 10.1

10.2 DRINK TOO HARD AND COLD

- A. If the drink is too hard and cold or the chamber is not full, adjust the “level control” to a higher level setting. Use the recommended settings that follow to properly adjust the liquid level control settings.
- B. It will be necessary to drain off several drinks to allow the chamber to fill and rebalance. It is also then necessary to defrost the chamber and allow the product to refreeze. If the drink is still too hard, repeat the process taking the level control setting to the next higher value.

10.3 DRINK TOO LIQUID

- A. If the drink is cold, but is still a liquid, adjust the level control to a lower level setting. Use the recommended settings that follow to properly adjust the level control.

- B. It will be necessary to drain off several drinks to allow the chamber to fill and rebalance. It is then necessary to defrost the chamber and allow the product to refreeze. If the drink is still too liquid, repeat the process taking the level control to the next lower setting.
- C. Drink temperature should be between 24°F and 28°F (-4.4°C to -2.2°C).

NOTE

If “Wet” or “Dry” drinks are common to both chambers, adjust “Regulated CO₂” up to lighten drink or down to make drink wetter before adjusting level controls!

10.4 CHANGING THE DEFAULT LEVEL CONTROL SETTING

- A. The level control setting is preset at the factory at a value of 3.
- B. If the drink is not frozen enough, or if the drink is too hard and too cold and dispenses slowly, after the machine has been running for 10 to 15 minutes, it may be necessary to adjust the level control settings.
- C. To change the machine’s level control settings, access the level two **service menu**.
 1. Access the service level by pressing the “FWD” button on the control panel until the “SERVICE MENU” displays. Press the unmarked button on the left side of the panel (press the unmarked button in the center of the panel for the 563). “Machine Settings” displays.
 2. Press the “SELECT” button, and then press “FWD” until you see the chamber you want to change.
 3. Press “SELECT” and “Level Control” displays.
 4. Press the “SELECT” button and the default setting of “3” begins to flash. The level is raised by pressing the “FWD” button and lowered by pressing the “BACK” button. When the desired number is reached, press “SELECT” and the new setting stops flashing and is set into the computer.
- D. When settings are complete, press the “CANCEL” button until “Copyright” displays.

NOTE

If the machine continues to yield a drink that is too liquid or too hard after changing level control settings, it may be necessary to adjust the THAW and FREEZE settings (refer to Section 11, Changing Factory Thaw And Freeze Settings).

11. CHANGING FACTORY THAW AND FREEZE SETTINGS

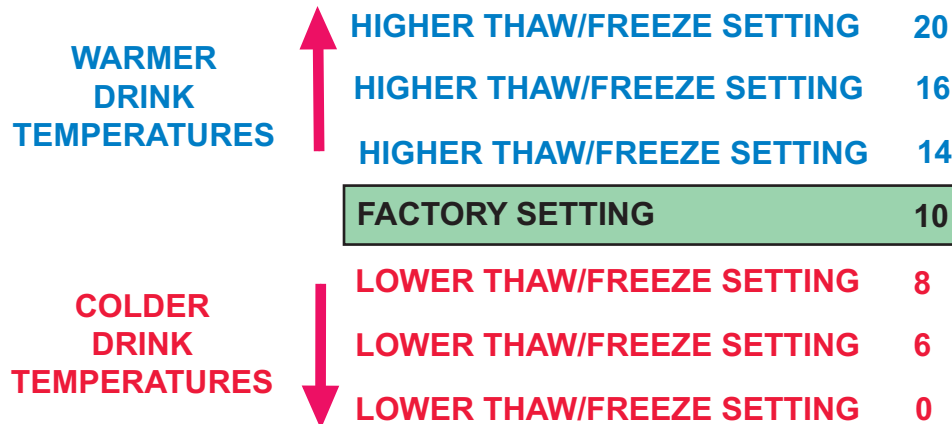

Recommended “THAW-FREEZE” Settings
Figure 11.1

11.1 BEFORE CHANGING THAW AND FREEZE SETTINGS

- A. *Each machine ships with THAW and FREEZE values preset. **These values should be correct for normal operation of the machine and are designed to produce a drink temperature between 24 and 28 degrees. Before making any changes to THAW AND FREEZE settings, check drink temperature. If drink temperature is within correct range, DO NOT CHANGE THAW-FREEZE SETTINGS.***
- B. *Before changing the THAW or FREEZE settings, verify that the level control and Brix settings are properly set. After verifying the “Level Control”, defrost all chambers by pressing the “DEF”*

buttons located on the control panel. The machine may correct any problems with drink quality after going through a defrost cycle.

1. After the defrost and refreeze cycle, the compressor may cycle on and off several times to ensure that the product is uniformly frozen. *Wait several minutes, and dispense several drinks, before judging the quality of the product.*
2. The product should freeze to a proper frozen texture, thaw, and refreeze to the same general texture. The compressor turns on when the thawed product requires refreezing and shuts off when the product is frozen enough.
3. If the product is freezing too cold (below 24°F), the THAW - FREEZE value may be increased. If the product is not cold enough (above 28°F), the THAW - FREEZE value may be decreased. *Use the recommended settings that follow when making adjustments to the THAW - FREEZE value.*

11.2 CHANGING THAW AND FREEZE SETTINGS

The THAW-FREEZE values should only be changed if the drink quality is not as expected. Use the following steps to change THAW-FREEZE settings as necessary. Before changing the THAW-FREEZE settings, verify that the brix and level control settings (see Section 10.1) are properly set. THAW-FREEZE settings may not need changing if corrections are made to the level control settings.

A. Changing the THAW-FREEZE values

1. Access the service level by pressing the “FWD” button on the control panel until the “SERVICE MENU” displays. Press the unmarked button on the left side of the panel (press the unmarked button in the center of the panel for the 563). “Machine Settings” displays.
2. Press “SELECT” and the “FWD” until you see the chamber you want to change.
3. Press “SELECT” and “LEVEL CONTROL” displays.
4. Press the “FWD” button until “THAW-FREEZE” displays.
5. To change the THAW-FREEZE values, press “SELECT” and the number starts to flash.
6. Press “FWD” to change to a higher setting or press the “BACK” button to change to a lower setting.
7. Once the desired setting displays, press “SELECT” to save the new value.
8. To change settings for the other chambers, press “CANCEL” and the “FWD” until desired chamber is displayed and press “SELECT.” Repeat Steps 3-7 above. Repeat for all chambers to be adjusted.
9. When settings are complete, press the “CANCEL” button until “Copyright” displays.

12. CRITICAL INFORMATION

The following information is critical to proper machine operation. Prior to troubleshooting problems with the unit, review the following information.

12.1 CHAMBERS 90% FULL ON INITIAL SET UP

Before beginning a RUN-FREEZE cycle, the chambers should be filled approximately 90% full (up to relief valve). If the chambers are above the 90% level, with Fill Off, open the dispensing valve and allow a small amount of liquid to drain out. If the chambers are not 90% full, press “OFF”, then “FILL”, and then slowly pull the vent ring on the faceplate to vent gas, and allow liquid to fill. The screen will display “Filling”. *Fill slowly and do **NOT** let the pressure drop more than three to four (3-4) psi.*

12.2 LINE VOLTAGE DROP

The **FBD562** and **FBD563** units require a separate electrical circuit complete with a 20 Amp breaker or fuse on a 20 Amp service. The **FBD564** unit requires a separate electrical circuit complete with a 30 Amp breaker or fuse on a 30 Amp service. The units will not function properly if the line voltage drops more than 10 volts between the power source and the machine.

12.3 LONG TUBING RUNS

A. Long runs of supply tubing can cause problems if the pressure drop (between the CO₂ tank or syrup source and the unit) is too much. Runs longer than 25 feet (7.62 m) will require special attention. The machine’s sensors may indicate that the machine is out of syrup, water, or CO₂. Consider the following solutions:

1. Increase the tubing size from 3/8 inch diameter to 1/2 inch diameter.

2. Install booster pumps in the supply lines. Use a vacuum regulating valve with syrup booster pumps.
3. Increase primary CO₂ regulator pressure from bulk or tank CO₂ to 105 - 120 psig (723.9 to 827.4 kPag). A secondary regulator will be necessary for pumps (syrup, water) to avoid exceeding manufacturer's recommended operating pressures.

13. TROUBLESHOOTING GUIDE

The following information is a listing of the most common problems that could keep the FBD56X Series Dispenser from operating properly. Contact the factory for details, when necessary.

<u>TROUBLE</u>	<u>CAUSE</u>	<u>REMEDY</u>
MECHANICAL		
<p>13.1 Chamber will not fill.</p> <div style="background-color: #c6e0b4; padding: 5px; margin-top: 10px;"> <p>NOTE: H₂O readout will be 15-20 psi higher on the readouts. Keep regulated pressure at 70-72 psig.</p> </div>	<p>A. "Fill" off.</p> <p>B. Pressure in chamber above "RFill" (refill) point.</p> <p>C. "Defrosting" or "Sleeping".</p> <p>D. Out of CO₂, Syrup or Water.</p> <p>E. Tank Pressure readout not moving between 18 and 40 psig or doesn't lower when chamber pressure is reduced.</p> <p>F. Solution or CO₂ solenoid valve won't open.</p> <p>G. Relay board not sending power to solenoid coils.</p> <p>H. Lower Board problem.</p> <p>I. 192 VA Transformer problem.</p>	<p>A. Press "Fill" button. "Filling" or "Fill Hold" will appear on LCD display.</p> <p>B. Gently pull faceplate relief valve ring to relieve pressure in chamber.</p> <p>C. Press "Def," then "Run." Wait for unit to freeze and red light to go out.</p> <p>D. Check LCD messages for "Out of" condition.</p> <p>E. Observe "Tank Transducer" in "Readouts". Check transducer and replace if necessary.</p> <p>F. In "Manual On/Off, energize solenoid and check for 24VAC at coil. Clean or replace solenoid if necessary</p> <p>G. Test solenoid relay on relay board for 24VAC output and 5VDC input. Replace Relay Board, if necessary.</p> <p>H. Check Lower Power Board for +5, +15, and -15 indicator lights. If green lights are not energized, replace board, if necessary.</p> <p>I. Test transformer for 220VAC input. Also check for 24VAC and 12VAC output (see Figures 14.7-14.13). Replace transformer if necessary.</p>
<p>13.2 Chamber fills even when turned off</p>	<p>A. Solution solenoid plunger sticking.</p> <p>B. Solution solenoid energized.</p> <p>C. Solution solenoid left "ON" in "Manual".</p>	<p>A. In "Manual On/Off", energize solenoid and check for 24VAC at coil. Clean or replace solenoid, if necessary.</p> <p>B. Test solenoid relay on relay board for 24VAC output and 5VDC relay coil input. Replace Relay Board, if necessary.</p> <p>C. In "Manual On/Off", turn solenoid off.</p>
<p>13.3 Out of Product displayed (Out of Water, Syrup or CO₂).</p>	<p>A. Unit receiving no water, syrup and/or CO₂.</p> <p>B. Restriction in lines.</p> <p>C. Regulator pressures (unit and syrup pumps) too low.</p>	<p>A. Assure water is on and CO₂ supply is not empty or turned off. Also check to see that syrup container is not empty and is hooked up.</p> <p>B. Assure all lines are free of crimps or restrictions.</p> <p>C. Check pressure readouts (H₂O, CO₂ and Syrups) for 70-72 psig. Adjust regulators, if necessary.</p>

(Item 13.3 continued on next page.)

TROUBLE	CAUSE	REMEDY
<i>(Item 13.3 continued from previous page.)</i>	<p>D. Syrup or Water Pump failure.</p> <p>E. CO₂ or water can't keep up with unit demand.</p> <p>F. Excessive pressure drops in syrup lines.</p> <p>G. Transducer problem (H₂O, CO₂ or Syrup).</p> <p>H. Lower Board problem</p> <p>I. Upper Board Problem</p>	<p>D. Check all pumps and replace, if necessary.</p> <p>E. Reroute water or CO₂ lines to maximize supply pressure. Install Water Booster if necessary.</p> <p>F. Observe "Syrup Press" readouts as chamber fills to verify. Increase line diameter or relocate syrup source closer to unit. Syrup pressures may only be raised (by increasing pump CO₂ pressure) if separate regulators are installed for unit and syrup pumps. Never exceed pump manufacturer's recommended maximum CO₂ inlet pressure (see Section 12.4).</p> <p>G. Check pressure readouts (H₂O, CO₂ and Syrup) for 70-72 psig. If not within 2 psi, adjust regulator and/or check transducer. Replace transducer, if necessary.</p> <p>H. Check Lower Power Board for +5, +15, and -15 indicator lights. If green lights are not energized, replace board, if necessary.</p> <p>I. Circuits within Main Control (Upper) Board electronics read transducer pressures. Replace Main Control (Upper) Board, if necessary</p>
<p>13.4 Product does not flow freely or does not flow at all from dispensing valve.</p>	<p>A. Faulty CO₂ check valve.</p> <p>B. CO₂ solenoid valve won't open.</p> <p>C. Solution solenoid valve won't open.</p> <p>D. Ice particles in dispensing valve.</p> <p>E. Product in cylinder is frozen too hard or solid.</p>	<p>A. Inspect CO₂ check valve. Clean or replace.</p> <p>B. In "Manual On/Off, energize solenoid and check for 24VAC at coil. Clean or replace solenoid, if necessary.</p> <p>C. In "Manual On/Off", energize solenoid and check for 24VAC at coil. Clean or replace solenoid, if necessary.</p> <p>D. Run defrost cycle. If necessary, open and close dispensing valve several times or run warm water over valve.</p> <p>E. 1. Check water/syrup flow rates and brix. Adjust, if necessary (see Section 6.2). 2. Check Level Control setting. Adjust if necessary (see Section 10). 3. Check Thaw/Freeze settings. Adjust if necessary (see Section 11). 4. Defrost chamber. Assure chamber is filled to 90%, then press "Run".</p>
<p>13.5 Product leaking from rear of cold pack.</p>	<p>A. Beater drive seal is worn or damaged.</p> <p>B. Beater drive coupling is worn.</p> <p>C. Seal is not positioned correctly.</p>	<p>A. Replace with new seal.</p> <p>B. Replace coupling.</p> <p>C. From inside chamber, reseal seal, making sure it is flush with back of chamber.</p>

TROUBLE	CAUSE	REMEDY
13.6 Brix sample valve leaks.	<ul style="list-style-type: none"> A. Damaged or failed seal or o-ring on valve. B. Inside of solution module is scratched or damaged. 	<ul style="list-style-type: none"> A. Turn off CO₂, water and disconnect syrup. Depressurize by opening sample valve. Remove clamp from sample valve. Remove sample valve, change o-ring and washer and reinstall. B. Replace solution module.
13.7 Low water pressure or no water pressure. <div style="background-color: #d9ead3; padding: 5px; border: 1px solid #d9ead3;"> <p>NOTE: H₂O readout will be 15-20 psi higher on the readouts. Keep regulated pressure at 70-72 psig.</p> </div>	<ul style="list-style-type: none"> A. Water not turned on or line restriction. B. CO₂ not turned on or too low. C. Water pressure transducer failure. D. Water pump failure. 	<ul style="list-style-type: none"> A. Turn on water. Check for line restrictions. B. Assure CO₂ is turned on and verify "CO₂ Press" readout is 70-72 psig. C. Verify "H₂O Pressure" readout at 70-72 psig. Check transducer and replace, if needed. D. Check water pump and replace, if necessary.
13.8 Noisy condenser fan.	<ul style="list-style-type: none"> A. Fan contacting condenser, fan blade guard, or other part. B. Loose fan bracket fasteners. 	<ul style="list-style-type: none"> A. Remove fan guard and adjust fan up or down as required. Remove obstruction as necessary. Reinstall fan guard. B. Tighten loose fasteners.
ELECTRICAL		
13.9 Solenoids not activating.	<ul style="list-style-type: none"> A. Solenoid plunger not lifting. B. Relay Board failure. C. Connectors not plugged in at board or solenoid. 	<ul style="list-style-type: none"> A. In "Manual On/Off", energize solenoid on and off checking for plunger movement and 24VAC at coil. Clean or replace solenoid, if necessary. B. Test solenoid relay on Relay Board for 24VAC output and 5VDC input. Replace, if necessary. C. Assure connections are clean and secure at P7, P8 and solenoid coils.
13.10 Solenoids continuously activated.	<ul style="list-style-type: none"> A. Solenoid plunger not dropping. B. Solenoid Relay stuck. C. Transducer failure. 	<ul style="list-style-type: none"> A. In "Manual On/Off", energize solenoid on and off checking for plunger movement and 24VAC at coil. Clean or replace solenoid, if necessary. B. Test solenoid relay on Relay Board for 24VAC output and 5VDC relay coil input. Replace, if necessary. C. Observe "Tank Pressure" readouts and check corresponding transducer. Replace transducer, if necessary.
13.11 Line voltage low on LCD.	<ul style="list-style-type: none"> A. Low voltage to unit (below 215 volts). B. Incorrect voltage offset. C. Voltage Offset transformer problem. 	<ul style="list-style-type: none"> A. Check voltage at L1 & L2 of contactor and at wall receptacle. Install Buck/Boost transformer, if necessary (see Section 4). B. Access "Machine Settings" menu and adjust voltage offset so "Line Voltage" readout equals L1 and L2 contactor voltage (see Section 6.1). C. Check CTRL_P6 on upper board for 24VAC. Replace transformer, if necessary.

TROUBLE	CAUSE	REMEDY
13.12 Low beater counts.	A. Chamber is frozen too hard or solid. B. Lower motor control board failure. C. Beater motor capacitor. D. Beater motor problem.	A. Verify correct brix, Level Control and Thaw/Freeze settings. Defrost chamber, refill to 90% and refreeze (see Sections 9.1, 10 and 11). B. Replace board. C. Check motor capacitor and replace, if necessary. D. Replace beater motor.
13.13 Excessively rapid rising/falling beater counts.	A. Lower Board problem. B. Buck/Boost transformer problem (if used).	A. Replace lower board. B. Disconnect and replace Buck/Boost transformer.
13.14 Display door light out or flickering.	A. Failed fluorescent tube. B. Blown fuse. C. Failed or failing fluorescent ballast. D. Failed LEDs.	A. Replace fluorescent tube. B. Check inline fuse (in electrical box.) Check wiring from contactor, through ballast, to lamp connection. C. Replace ballast. D. Replace failed LED strip.
13.15 Ammonia smell in electrical box.	A. Start capacitor has failed.	A. Verify blown capacitor. Replace start capacitor and check start relay. Replace if necessary.
13.16 Fan motor not running.	A. Unit in "Defrost" cycle. B. Failed compressor or fan relay on relay board. C. Lower motor control board failure. D. Contactor not engaging. E. Bad fan motor.	A. Check fan after completion of defrost cycle. B. Test compressor or fan relays on Relay Board for 24VAC output and 5VDC input. Replace Relay Board, if necessary. C. Replace lower board. D. Check for 24 volt at coil and 220 volt at T1 and T2. Replace contactor, if necessary. E. Replace fan.

ELECTRONIC CONTROLS

13.17 LCD readout garbled or blank.	A. Voltage spike or noise. B. Low or no voltage to unit or loss of 5VDC signal.	A. Press "CANCEL" several times. B. Check L1 & L2 of contactor for 220 VAC and indicator light on the lower board for +5 VDC. Install Buck/Boost transformer or replace lower board, if necessary.
13.18 One or more keypad buttons will not function.	A. Cable connecting Main Control (upper) board to keypad not connected properly. B. Faulty control cable.	A. Check for loose or incorrect connections. B. Replace keypad.
13.19 Clock shows incorrect time/date.	A. Initial setting incorrect. B. Clock battery failure.	A. Change clock settings as described in Section 7.2 of this manual. B. Replace clock battery on upper board.
13.20 Faulty tank pressure reading on LCD.	A. Pressure transducer failure. B. Possible short in wiring from transducer to PC board. C. Poor contact within connector.	A. Check transducer and replace, if necessary. B. Clean and dry both ends of cable, and check for loose connections. C. Reposition or replace transducer.

(Item 13.20 continued on next page.)

TROUBLE	CAUSE	REMEDY
<i>(Item 13.20 continued from previous page.)</i>		
	D. Low 15VDC from Lower Board. E. Upper board failure.	D. Check indicator light for 15VDC on lower power board. Replace lower board, if necessary. E. Replace main control (Upper) board.
REFRIGERATION		
<p>13.21 Compressor won't start.</p> <div data-bbox="99 520 451 703" style="background-color: #d9ead3; padding: 5px;"> <p>NOTE: H2O readout will be 15-20 psi higher on the readouts. Keep regulated pressure at 70-72 psig.</p> </div> <div data-bbox="99 863 695 995" style="background-color: #fff2cc; padding: 5px; margin-top: 10px;"> <p>NOTE: Contact FBD Customer Service at 866-323-2777 for questions concerning compressors and operational issues.</p> </div>	A. Incorrect start procedure. B. Out of CO ₂ , Syrup or Water. C. Run capacitor problem. D. Contactor failure. E. Relay board not sending power to contactor coil. F. Lower Board problem. G. 192 VA Transformer problem. H. Compressor failure, or overheated.	A. Press "Def", then "Run" to start. B. Check pressure readouts for 70-72 psig, adjust regulators, if necessary. C. Test run capacitor. Replace, if necessary. D. 1. In Manual On/Off, activate "Compressor." DO NOT RUN COMPRESSOR FOR MORE THAN 10 SECONDS! If contactor energizes, quickly check voltage across contactor T1 and T2 for 220 volt. If no voltage reading, replace contactor. " 2. In Manual On/Off, activate "Compressor." DO NOT RUN COMPRESSOR FOR MORE THAN 10 SECONDS! If contactor does not energize, quickly check voltage across contactor coil terminals for 24VAC. If voltage is present, replace contactor. E. Test relay board for 24VAC output and 5VDC input on contactor relay. Replace relay board, if necessary. F. Check lower board for +5, +15, and -15 indicator lights. If green lights are not energized, replace board, if necessary. G. Test transformer for 220VAC input and 24VAC and 12VAC output (see Section 14, Board Schematics). H. Wait for compressor to cool. Check amperage draw on compressor. Check compressor wiring and terminals. Replace compressor,
Contact FBD Warranty Dept. at 866-323-2777 before tapping system if unit is under warranty!		
<p>13.22 Compressor runs long time but won't freeze down.</p>	A. Return temperature not dropping. B. Airflow through condenser is blocked. Dirty filter. C. Hot gas valve is activated in Manual On/Off	A. Verify that Return Temperature drops below 25°F. Return Temperature should achieve 20-25°F within 7 to 25 minutes of startup (no drinks dispensed). B. Clear condenser of blockage. Clean air filter. C. Select "Defrost Sol" in "Manual ON/OFF"; test solenoid, then turn off.

(Item 13.22 continued on next page.)

TROUBLE	CAUSE	REMEDY
<p><i>(Item 13.22 continued from previous page.)</i></p>	D. Base refrigeration settings.	D. Load all Defaults to ensure factory settings.
	E. Hot gas valve is stuck open, or debris is preventing valve from closing.	E. Recover refrigerant and remove blockage or replace valve, if necessary. Recharge system with R404-A, using the specifications label on the backside of the machine.
	F. Expansion valve not opening.	F. 1. Test expansion valve coil to ensure it is receiving 24VAC. Replace expansion valve if plunger inside doesn't move. Contact FBD Warranty Dept. before tapping system if unit is under warranty! Recover refrigerant and replace valve. Recharge system with R404-A, using the specifications label on the backside of the machine. 2. Test relay board for 24VAC output and 5VDC relay coil input. Replace, if necessary.
	G. Expansion valve restriction.	G. Contact FBD Warranty Dept. before tapping system if unit is under warranty! Recover refrigerant and remove blockage or replace valve, if necessary. Recharge system with R404-A, using the specifications label on the backside of the machine.
	H. Refrigeration leak or low refrigerant charge.	H. Contact FBD Warranty Dept. before tapping system if unit is under warranty! Put gages on system and check pressures. Single side suction should be 32-35 psig , dual side 42-45 psig. Single and dual side discharge should be 275-300 psig . Check for and repair leaks, recharge system with R404-A, using the specifications label on the backside of the machine.
<p>NOTE: Contact FBD Customer Service at 866-323-2777 for questions concerning compressors and operational issues.</p>	I. Water is not turned on for water condenser inlet.	I. Ensure water is turned on for the water condenser inlet.
	CAUTION DO NOT PRESSURIZE LOW SIDE (EVAPORATOR AND COMPRESSOR SUCTION) ABOVE 150 psig FOR ANY REASON! COMPONENTS WILL FAIL AND WARRANTIES WILL BE VOID.	
13.23 High head/suction pressure.	A. Condensor air flow restricted. B. Compressor damage C. High ambient temperature. D. Water is not turned on for water condenser inlet.	A. Check for air flow restriction, clean condensor and air filter. B. Check amp draw on compressor. C. Temperature surrounding unit should be less than 90°F. D. Ensure water is turned on for the water condenser inlet.

Contact FBD Warranty Dept. at 866-323-2777 before tapping system if unit is under warranty!

TROUBLE	CAUSE	REMEDY
13.24 Low head/suction pressure.	A. Low refrigerant level.	A. See item 13.22.H above.

Contact FBD Warranty Dept. at 866-323-2777 before tapping system if unit is under warranty!

DRINK QUALITY

<p>NOTE: For low carbonation applications, see Quick Reference Sheet on page 4 for settings information.</p>	<p>13.25 Drink too "Wet" or "Liquid".</p>	<p>A. Chamber not filled properly. B. CO₂ check valve clogged. C. CO₂ solenoid not opening. D. CO₂ level in drink too low. E. Secondary CO₂ regulator malfunctioning. F. Reg'd CO₂ Transducer malfunctioning. G. Incorrect Brix or water/syrup flow rates. H. Tank Pressure readout not moving between 18 and 40 psig or doesn't lower when chamber pressure is reduced. I. Relay board not sending power to CO₂ solenoid coil. J. "THAW/FREEZE" settings are set too high. K. CO₂ orifice is blocked.</p>	<p>A. Defrost, then assure chamber is 90% full. B. Clean or replace check valve. C. Activate "CO₂ Sol" in "Manual On/Off". Check for 24VAC at coil. Clean solenoid or replace, if necessary. D. 1. To affect ALL chambers, raise "Reg.CO₂" within 28-32 psig range. 2. To affect ONE chamber, lower the level control settings using the instructions in Section 10.2 of this manual E. Check Secondary Regulator. Repair or replace secondary regulator if necessary. F. Check "Reg'd CO₂" in readouts, compare with regulator gauge. Test transducer, replace if necessary. G. Check water and syrup flows and adjust if necessary. Then check brix (see Section 6.2). H. Observe Tank Transducer, check and replace, if necessary. I. Test relay board for 24VAC output and 5VDC input on solenoid relay. Replace Relay Board, if necessary. J. Lower the "THAW/FREEZE" settings, using the instructions in Section 11.2, this manual. K. Remove blockage.</p>
---	--	---	--

<p>NOTE: For low carbonation applications, see Quick Reference Sheet on page 4 for settings information.</p>	<p>13.26 Drink quality is too light.</p>	<p>A. Chamber not filled properly. B. Incorrect Brix or water/syrup flow rates. C. CO₂ level in drink too high. D. Secondary Regulator pressure rise. E. "THAW/FREEZE" settings set too low.</p>	<p>A. Defrost and assure chamber is 90% full.. B. Check water and syrup flows and adjust if necessary. Then check brix (see Section 6.2). C. 1. To affect ALL chambers, lower "Reg.CO₂" within 28-32 psig range. 2. To affect ONE chamber, raise the level control settings using the instructions in Section 10.2 of this manual D. Pressure rising out of 28-32 psig range. Repair or replace the secondary regulator if necessary. E. Raise the "THAW/FREEZE" settings using the instructions in Section 11.2 of this manual.</p>
---	---	--	---

(Item 13.26 continued on next page.)

TROUBLE	CAUSE	REMEDY
<i>(Item 13.26 continued from previous page.)</i>		
	F. Solution Solenoid malfunctioning and not allowing the chamber to fill. G. Relay board not sending power to solution solenoid coil.	F. Activate "Solution Sol" in Manual On/Off. Check for 24VAC at coil. Clean solenoid or replace, if necessary. G. Test relay board for 24VAC output and 5VDC input on solenoid relay. Replace Relay Board, if necessary.
13.27 Drinks "collapse" or "fall". (CO ₂ is escaping from the drink.) <div style="background-color: #d4edda; padding: 5px; border: 1px solid #c3e6cb;"> <p>NOTE: For low carbonation applications, see Quick Reference Sheet on page 4 for settings information.</p> </div>	A. Chamber not filled properly. B. CO ₂ level in drink too high. C. "THAW/FREEZE" settings are set too low. D. Air not cleared from chamber prior to filling chamber. E. Contaminated Syrup supply. F. Contaminants in product from excessive lubrication of valve or seal. G. Contaminated CO ₂ or water supply.	A. Defrost and assure chamber is 90% full. Then press "Run". B. 1. To affect ALL chambers , lower "Reg.CO ₂ " within 28-32 psig range. 2. To affect ONE chamber , raise the level control settings (using the instructions in Section 10.2 of this manual). C. Raise the "THAW/FREEZE" using the instructions in Section 11.2. D. Follow "Filling the chamber" instructions in Section 6.3. E. Syrup being used is more than three (3) months old, or is not an FCB syrup. F. Flush chamber and remove excess lubrication contaminants. G. Contact CO ₂ supplier or plumber.
13.28 Drink tends to "grow" or continue to expand in volume after drawn into cup. <div style="background-color: #d4edda; padding: 5px; border: 1px solid #c3e6cb;"> <p>NOTE: For low carbonation applications, see Quick Reference Sheet on page 4 for settings information.</p> </div>	A. "THAW/FREEZE" settings are set too high. B. Incorrect Brix or water/syrup flow rates. C. CO ₂ level in drink too high.	A. Lower the "THAW/FREEZE" settings using the instructions in Section 11.2, this manual. B. Check water and syrup flows and adjust if necessary. Then check brix (see Section 6.2). C. 1. To affect ALL chambers , lower "Reg.CO ₂ " within 28-32 psig range. 2. To affect ONE chamber , raise the level control settings using the instructions in Section 10.2 of this manual.

LCD DISPLAY ERROR MESSAGES

13.29 PresMx, Pressure Maximum	A. Chamber pressure above 55 psig. B. Expansion tank pressure system not working properly. C. Tank transducer shorted at 99 psig. D. Level Control set too high.	A. Dispense one (1) drink; see if PMAX recurs. B. Replace expansion tank active charge regulator. <div style="background-color: #d4edda; padding: 5px; border: 1px solid #c3e6cb;"> <p>NOTE: <i>This is not the same regulator as used on the header.</i></p> </div> C. Replace transducer. D. Level Control settings may need to be lowered. Set the Level Control using the instructions in Section 10.2 of this manual.
--	---	--

(Item 13.29 continued on next page.)

TROUBLE	CAUSE	REMEDY
<p><i>(Item 13.29 continued from previous page.)</i></p> <div data-bbox="105 401 456 594" style="background-color: #d9ead3; padding: 5px;"> <p>NOTE: For low carbonation applications, see Quick Reference Sheet on page 4 for settings information.</p> </div>	<p>E. Level Control too low.</p> <p>F. “Regulated CO2” transducer reading inaccurately.</p> <p>G. Secondary regulator pressure creeping up.</p> <p>H. CO2 check valve problem.</p>	<p>E. Level Control settings may need to be raised due to excessive CO2 in the chamber. Raise the Level Control settings using the instructions in Section 10.2 of this manual.</p> <p>F. Insure that the tank transducers are reading the CO2 regulated pressure correctly [i.e., filling about 5-7 psi (34.5-48.3 kPa) below “REG CO2”].</p> <p>G. Insure CO2 regulator has not climbed above preset 28-32 psig (193.1-220.6 kPag).</p> <p>H. Inspect CO2 check valve. Clean or replace if necessary.</p>
<p>13.30 MaxFil, Maximum Fill</p> <div data-bbox="105 722 456 869" style="background-color: #d9ead3; padding: 5px;"> <p>NOTE: For low carbonation applications, see Quick Reference Sheet on page 4 for settings information.</p> </div>	<p>A. Secondary CO2 pressure is set above 40 psig.</p> <p>B. Secondary regulator pressure creeping up.</p>	<p>A. Check Secondary CO2 for correct setting of 28-32 psig (193.1-220.6 kPag).</p> <p>B. Insure CO2 regulator has not climbed above 32 psig (220.6 kPag). Clean or repair or replace regulator, if necessary.</p>
<p>13.31 DefPMax, Defrost Pressure Maximum</p>	<p>A. Tank pressure above 55 psig.</p>	<p>A. See Section 13.29.</p>
<p>13.32 DefPrO, Defrost Product Out</p>	<p>A. Product supply is out during defrost stage.</p>	<p>A. Replenish product supply (i.e., water, CO2, syrup).</p>
<p>13.33 BTR-LO, Beater Count Low</p>	<p>A. Product freezing too hard. Beater % below 450.</p> <p>B. Bad capacitor on motor.</p> <p>C. Motor control board failure.</p>	<p>A. 1. Check brix and correct, if necessary. 2. Check Level Control and correct, if necessary. 3. Check for restriction of beater blades. 4. Check for failed beater motor.</p> <p>B. Check capacitor and replace as required.</p> <p>C. 1. Check connector from Beater Motor to lower control board. 2. Change lower control board if necessary.</p>
<p>13.34 SYROUT, Syrup Out</p>	<p>A. Unit receiving no syrup.</p> <p>B. Restriction in lines.</p> <p>C. Regulator pressures (unit and syrup pumps) too low.</p> <p>D. Syrup Pump failure.</p> <p>E. Excessive pressure drops in syrup lines.</p>	<p>A. Check to see that syrup container is not empty and is hooked up.</p> <p>B. Assure all lines are free of crimps or restrictions.</p> <p>C. Check Syrups pressure readouts for 70-72 psig. Adjust regulators, if necessary.</p> <p>D. Check pump and replace, if necessary.</p> <p>E. Observe “Syrup Press” readouts as chamber fills to verify. Increase line diameter or relocate syrup source closer to unit. Syrup pressures may only be raised (by increasing pump CO2 pressure) if separate regulators are installed for unit and syrup pumps. Never exceed pump manufacturer’s recommended maximum CO2 inlet pressure (see Section 12.3).</p>

(Item 13.34 continued on next page.)

TROUBLE	CAUSE	REMEDY
<i>(Item 13.34 continued from previous page.)</i>		
	F. Syrup Transducer problem. G. Lower Board problem. H. Upper Board Problem.	F. Check syrup pressure readouts for 70-72 psig. If not within 2 psi, adjust regulator and/or check transducer. Replace transducer, if necessary. G. Check lower power board for +5, +15, and -15 indicator lights. If green lights are not energized, replace board, if necessary. H. Circuits within Main Control (Upper) Board electronics read transducer pressures. Replace Main Control (Upper) Board, if necessary.
13.35 H2OOUT, Water Out <div data-bbox="191 747 561 928" style="background-color: #d9ead3; padding: 5px;"> <p>NOTE: H2O readout will be 15-20 psi higher on the readouts. Keep regulated pressure at 70-72 psig.</p> </div>	A. Unit receiving no water. B. Restriction in lines. C. Regulator pressures (unit water pump) too low or CO ₂ out. D. Water Pump failure. E. Water pressure too low, can't keep up with unit demand. F. Water Transducer problem. G. Lower Board problem. H. Upper Board Problem.	A. Assure water is turned on. B. Assure all lines are free of crimps or restrictions. C. Check pressure readouts (H ₂ O and CO ₂) for 70-72 psig. Adjust regulators, if necessary. Replenish CO ₂ supply. D. Check pump and replace, if necessary. E. Reroute water to maximize supply pressure. Install Water Booster, if necessary. F. Check water pressure readout for 70-75 psig. If not within 2 psi, adjust regulator and/or check transducer. Replace transducer, if necessary. G. Check lower power board for +5, +15, and -15 indicator lights. If green lights are not energized, replace board if necessary. H. Circuits within Main Control (Upper) Board electronics read transducer pressures. Replace Main Control (Upper) Board, if necessary.
13.36 CO2OUT, CO2 Out	A. Unit receiving no CO ₂ . B. Restriction in lines. C. Regulator pressures (to unit and syrup pumps) too low. D. CO ₂ can't keep up with unit demand. E. CO ₂ Transducer problem. F. Lower Board problem.	A. Assure CO ₂ supply is not empty or turned off. B. Assure all lines are free of crimps or restrictions. C. Check pressure readout (CO ₂) for 70-72 psig. Adjust regulators, if necessary. D. Increase CO ₂ line size to maximize supply pressure or supply unit dedicated CO ₂ source. Bulk regulator must be 105 psig minimum, CO ₂ line must be tied to main branch of bulk system, with step down regulator (set 70-72 psig) between tie-in and unit E. Check CO ₂ pressure readout for 70-72 psig. If not within 2 psi, adjust regulator and/or check transducer. Replace transducer, if necessary. F. Check lower power board for +5, +15, and -15 indicator lights. If green lights are not energized, replace board if necessary.

(Item 13.36 continued on next page.)

TROUBLE	CAUSE	REMEDY
<i>(Item 13.36 continued from previous page.)</i>	G. Upper Board Problem.	G. Circuits within Main Control (Upper) Board electronics read transducer pressures. Replace Main Control (Upper) Board, if necessary.
13.37 RTempE , Return Temperature Error	A. Temperature Sensor error or failure.	A. 1. Check for short in sensor and cable. LED on Main Control board goes bright if short occurs, goes out if open circuit and stays dim if working properly. 2. Check for poor connection in sensor plug. 3. Replace temperature sensor.
13.38 InTmpE , Inlet Temperature Error	A. Temperature Sensor error or failure.	A. 1. Check for short in sensor and cable. LED on Main Control board goes bright if short occurs, goes out if open circuit and stays dim if working properly. 2. Check for poor connection in sensor plug. 3. Replace temperature sensor.

NOTES

LCD DISPLAY MESSAGES

(# stands for the barrel number which is L, C, R, or 1, 2, 3, 4)

FBD56X SERIES FROZEN BEVERAGE DISPENSERS

MESSAGE	DESCRIPTION
Sleep	Unit in "Sleep" mode. Unit is shut down.
CmpSDI	This delay is before compressor starts. The time period varies from 1 to 20 seconds.
CmpStr	This is displayed when compressor starts freezing or defrosting.
CmpRun	This is displayed only on Left Side, when compressor is running.
DEF-WT	This side is waiting to defrost.
DEFBtr	If "DEF" is pressed and if the beater has not been running, then this is displayed.
DEF CWt	Time delay while the compressor is starting.
Defrst	This is displayed when side is DEFROSTING.
DEFSpd	This is displayed when a side has been interrupted by the other side freezing. After the other side has frozen down, then defrost is resumed.
RunOff	This is displayed when freeze is off or when the side is turned off.
RunHGW	This is displayed on the opposite side when a side has defrosted and is waiting to refreeze or when one side is defrosting and the other side is in Run Thaw Mode.
RunCWt	This is displayed, prior to starting a freeze down; this is a time delay when the compressor is starting.
RunFW	This is displayed after the freeze down has finished.
RunFrz	This is displayed when a side is freezing down.
RunThW	This is displayed after the Thaw percent has been reached.
RunTha	This is displayed when a side is Thawing before refreezing.
RunB	If "Run" is pressed and if the beater has not been running then this is displayed for a maximum time delay of two (2) minutes.
FIOff	The unit will not fill with product when this is displayed.
LFIH	This is displayed during first freeze. The pressure in the chamber has not dropped below the fill pressure.
Fill H	This is displayed during normal operations when the pressure in the chamber has not dropped below the fill pressure.
LfPCO2	This is displayed prior to filling the chamber with solution. This only allows CO ₂ into the chamber for a specified time period.
LfCO2S	This is displayed prior to filling the chamber with solution. This only allows CO ₂ and solution to fill the chamber until four (4) psig is reached in the chamber.
LFill	This is displayed during first freeze. The unit is filling the chamber.
Filling	This is displayed during normal operations when the chamber is filling.

LCD DISPLAY ERROR MESSAGES

(# stands for the barrel number which is L, C, R, or 1, 2, 3, 4)

FBD56X SERIES FROZEN BEVERAGE DISPENSERS

MESSAGE	DESCRIPTION	WILL CAUSE
DefPMx	Chamber pressure is above 55 psig during defrost only.	
DefPrO	Product is out during defrost only.	
BTR-LO	Low beater percent. Below 450%.	Fault Code History.
BTR-HI	High beater percent. Above 1200%.	
SYROUT	Syrup pressure is below 35 psig.	Fault Code History.
H2OOUT	Water pressure is below 35 psig.	Fault Code History.
CO2OUT	CO2 pressure is below 45 psig.	Fault Code History.
PresMx	Chamber pressure is above 55 psig during normal operations only.	Fault Code History.
RunPrO	Product out during normal operations.	
RTempE	High return temperature detected or temperature sensor broken (-40 to 97). Unit still functions.	
MaxFil	Regulated CO2 pressure is at or above 40 psig limit.	
Tnk Psi=0 #	Filling has been on for 30 seconds and chamber pressure equals to zero (0).	Fault Code History.
SFil Error #	Filling on for four (4) minutes but chamber pressure between one (1) psig and fill psig.	Fault Code History.
ProdOt	Product out when side needs to be filled.	
InTempE	High inlet temperature detected or temperature sensor broken (-40 to 97). Unit still functions. This error will occur during the DEFROST CYCLE.	
Cmp ran too long OFF	The compressor has run for more than one hour straight in a 562 or 563 dispenser (one hour and 20 minutes for the 564 dispenser). Check the air filter or the refrigeration charge.	All barrels go to OFF.
HOT PRODUCT SHUT DOWN	This means the product in the barrel is getting hot. A bad return temperature sensor may also be at fault.	All barrels go to OFF.
Stop BTR Long PMAX	The beater shuts off after fifteen (15) minutes of a PMAX error. It will restart automatically when the error is cleared.	This barrel goes to OFF.
Stop BTR LongPrd Out	The beater shuts off after fifteen (15) minutes of a sold-out condition. It will restart automatically when the sold-out has been cleared.	This barrel goes to OFF.

WARNING LIGHTS STATUS		SOLUTIONS		
		CAUSE	LCD DISPLAY	SOLUTION
RED light flashing (Any single barrel)	Lights flashing Any single barrel	Out of syrup for barrel	SYRUP OUT	Replace empty syrup (BIB) container.
All RED lights flashing (All barrels)	Lights flashing All barrels	(A) Out of CO ₂ (B) Out of water (H ₂ O)	(A) CO ₂ OUT (B) H ₂ OOUT	(A) Replace empty CO ₂ tank. (B) Check water (H ₂ O) supply.
RED light continuously on (any barrel)	Lights flashing Light flashing	Unit defrosting	DEFROSTING	If on defrost during peak draw, cancel defrost by pushing " Def ", then push " Run ". Wait until unit completes defrost and freeze down cycle.
All RED lights on and beaters not turning	All barrels light flashing and beaters not turning	Unit in first freeze after defrost (A) Unit is in "sleep" mode (B) Unit is turned off	No message on display (A) SLEEPING (B) RUN OFF	(A, B) Restart unit by pushing " Def " button, then " Run " button on both sides.
No lights and unit is not running	No lights and unit is not running	Unit is not plugged in or breaker has been tripped	No message on display	Plug in unit or reset circuit breaker. Then restart unit.

14. DIAGRAMS AND SCHEMATICS

14.1 MOUNTING DIAGRAM - FBD 562

This Figure illustrates the locations of threaded mounting holes in the base of the FBD562 units.

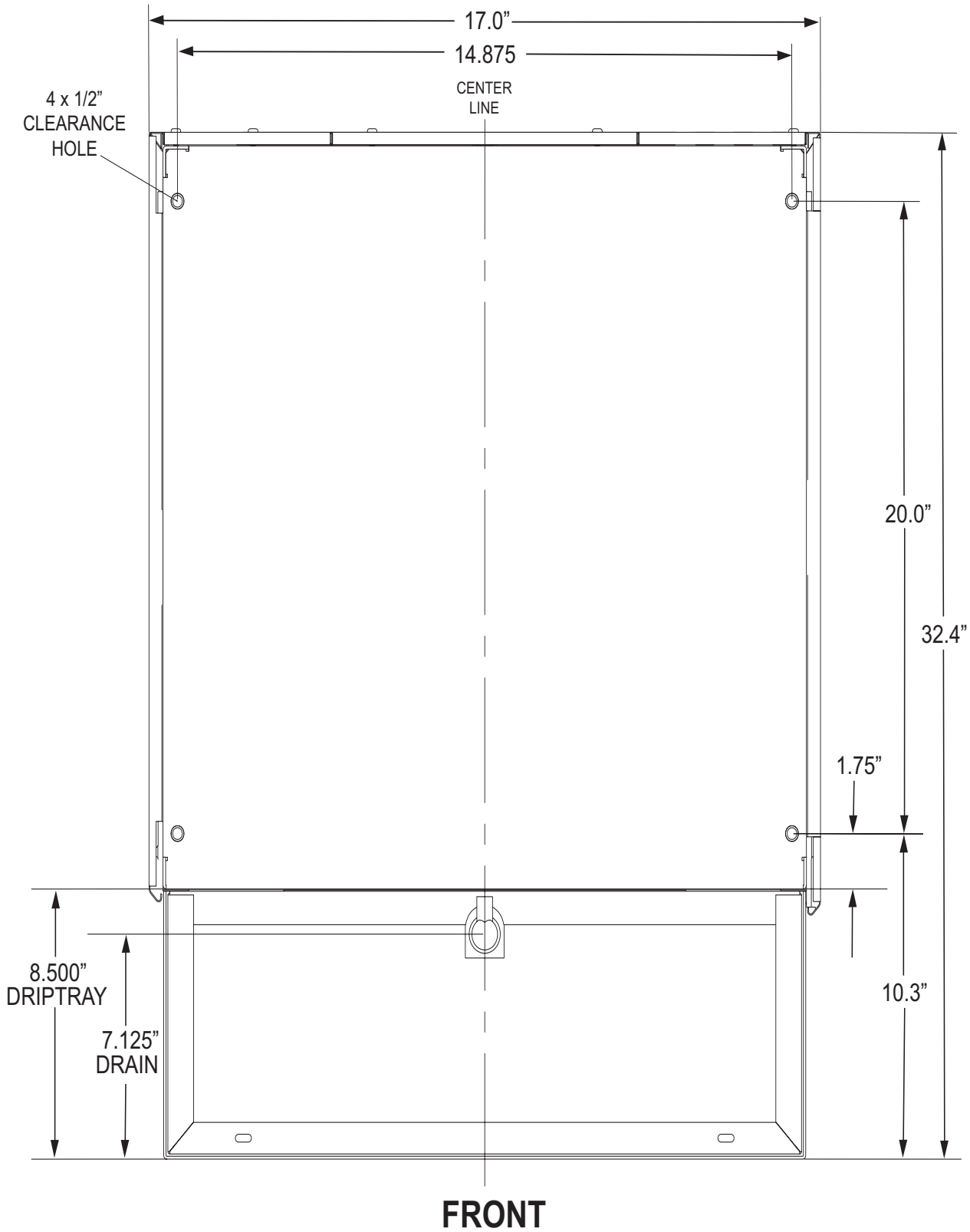

EDITOR'S NOTE: NOT DRAWN TO SCALE

14.2 MOUNTING DIAGRAM - FBD 563

This Figure illustrates the locations of threaded mounting holes in the base of the FBD563 unit.

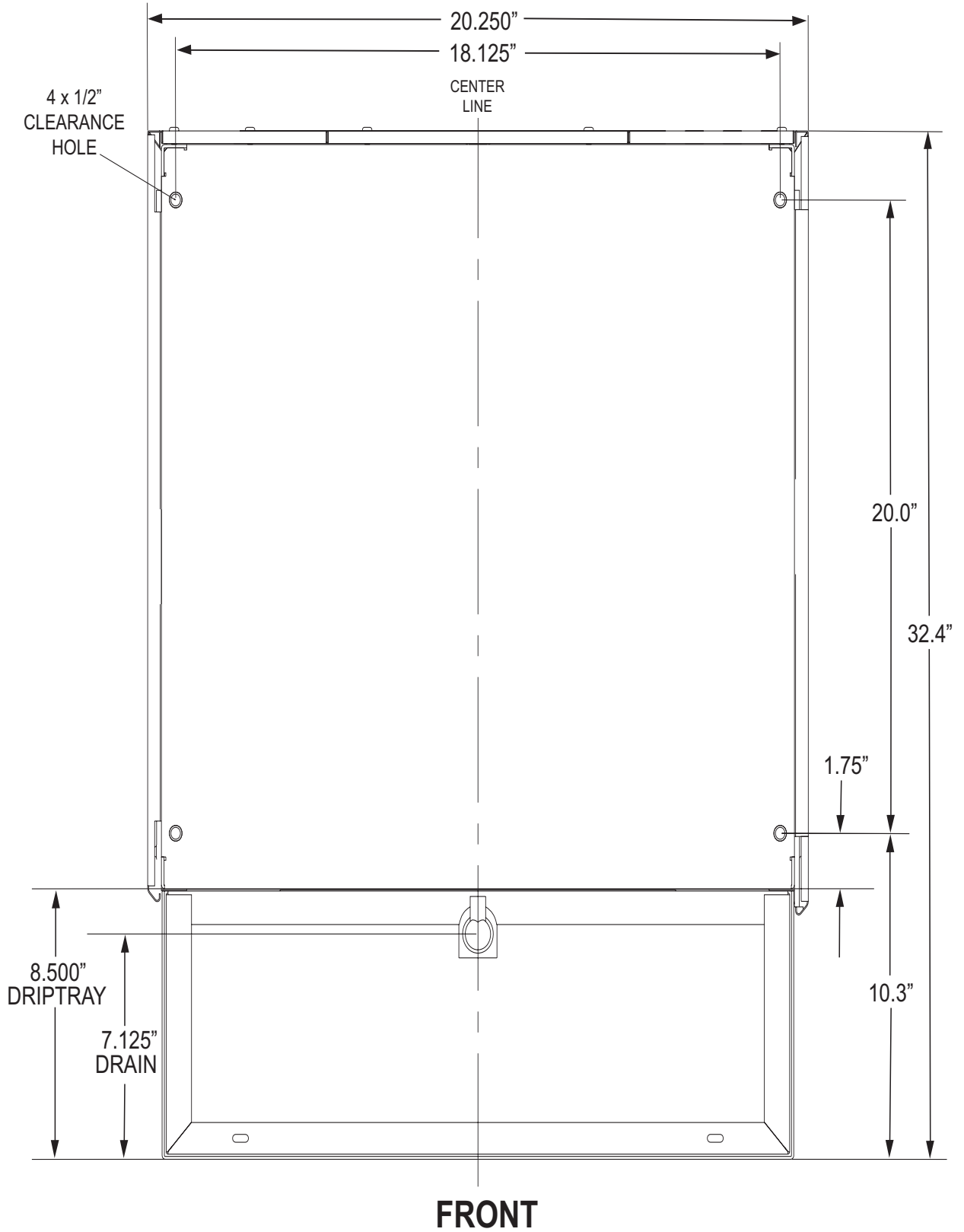

EDITOR'S NOTE: NOT DRAWN TO SCALE

14.3 MOUNTING DIAGRAM - FBD 564

This Figure illustrates the locations of threaded mounting holes in the base of the FBD564 unit.

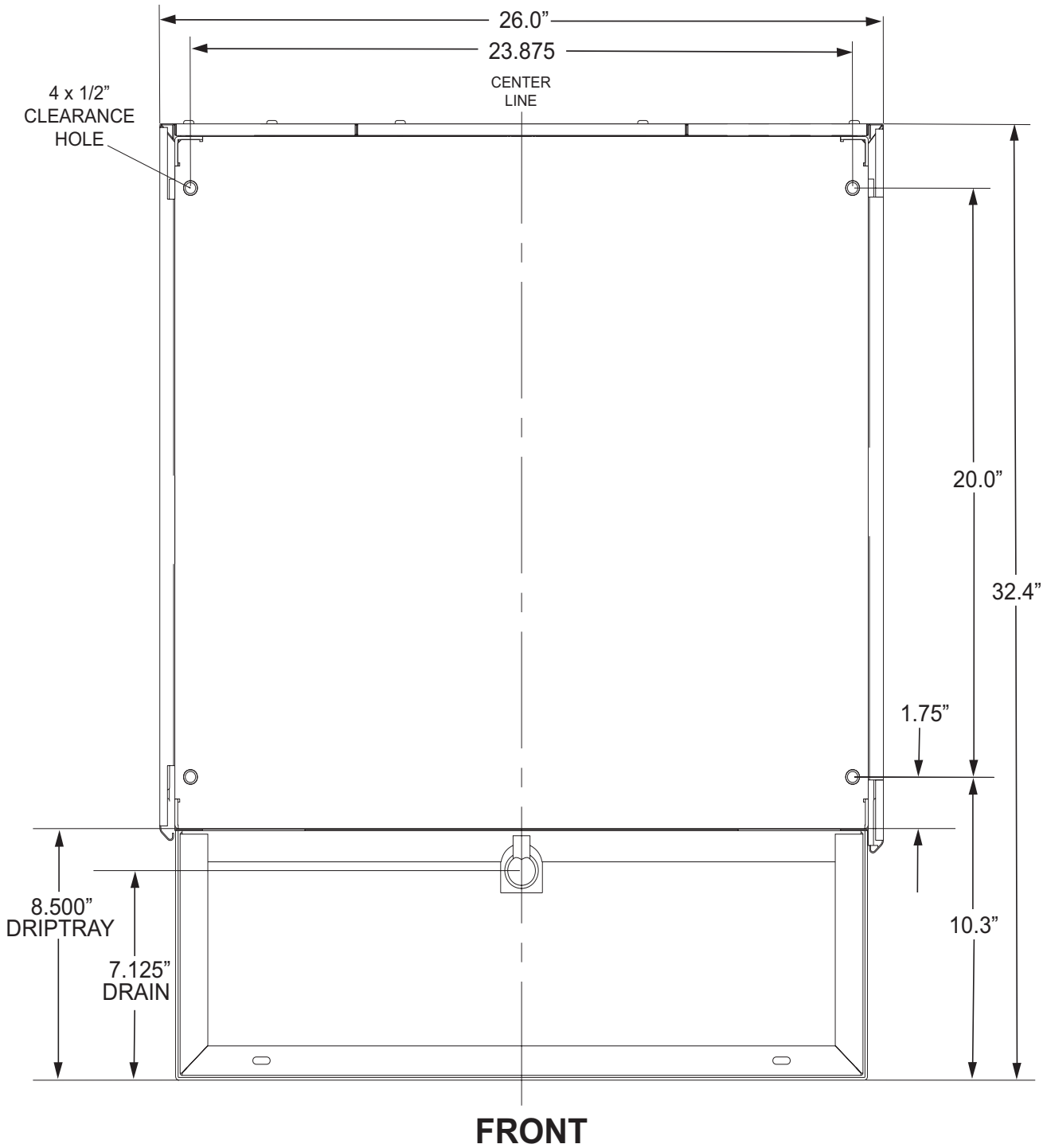

EDITOR'S NOTE: NOT DRAWN TO SCALE

14.4 FLOW DIAGRAM/SCHEMATIC - FBD 562

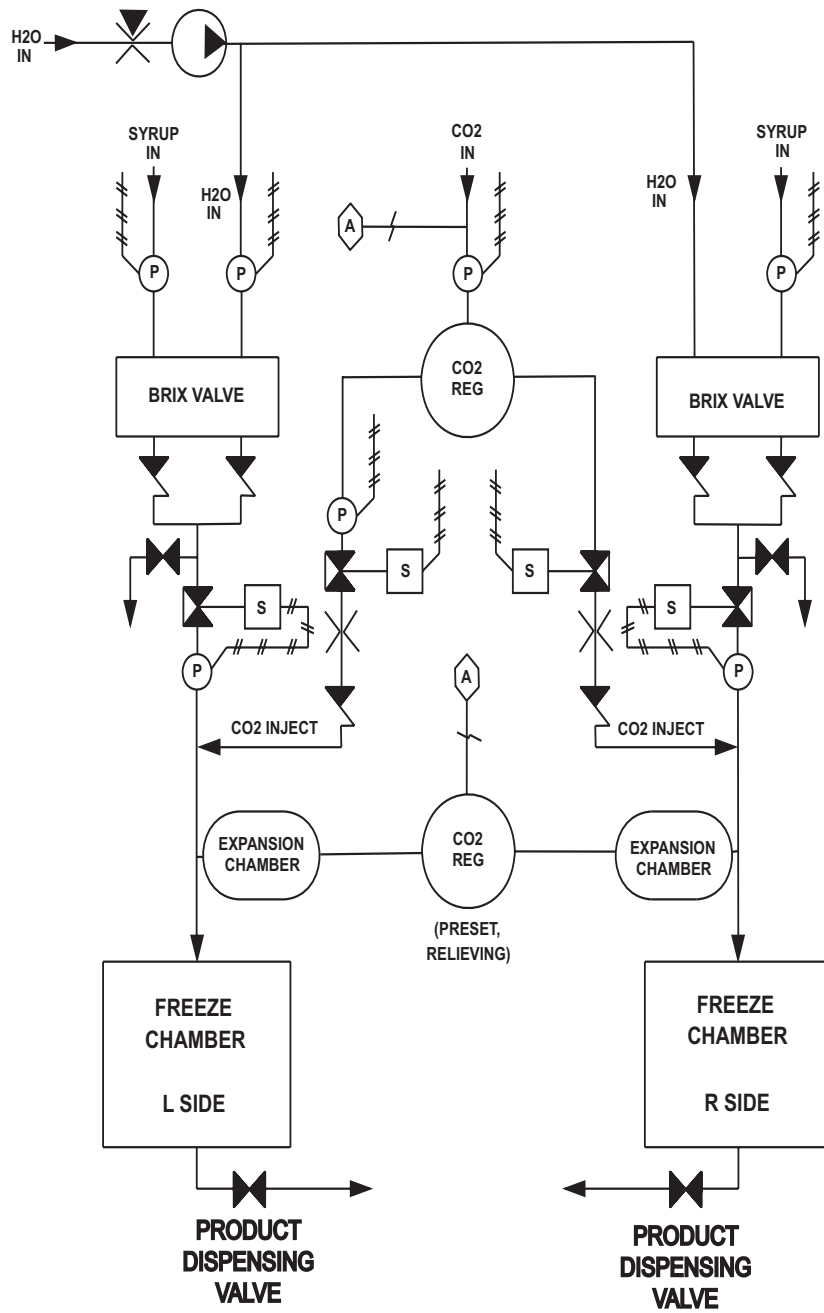

LEGEND		FIXED RESTRICTION		PRESSURE TRANSDUCER
		VARIABLE RESTRICTION		SOLENOID VALVE
		PUMP		DISPENSING VALVE
		CHECK VALVE		CO2 REGULATOR

NOTE:
PORT LOCATIONS AT
REAR OF EQUIPMENT

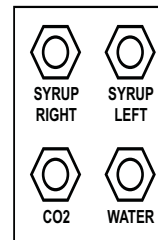

14.5 FLOW DIAGRAM/SCHEMATIC - FBD 563

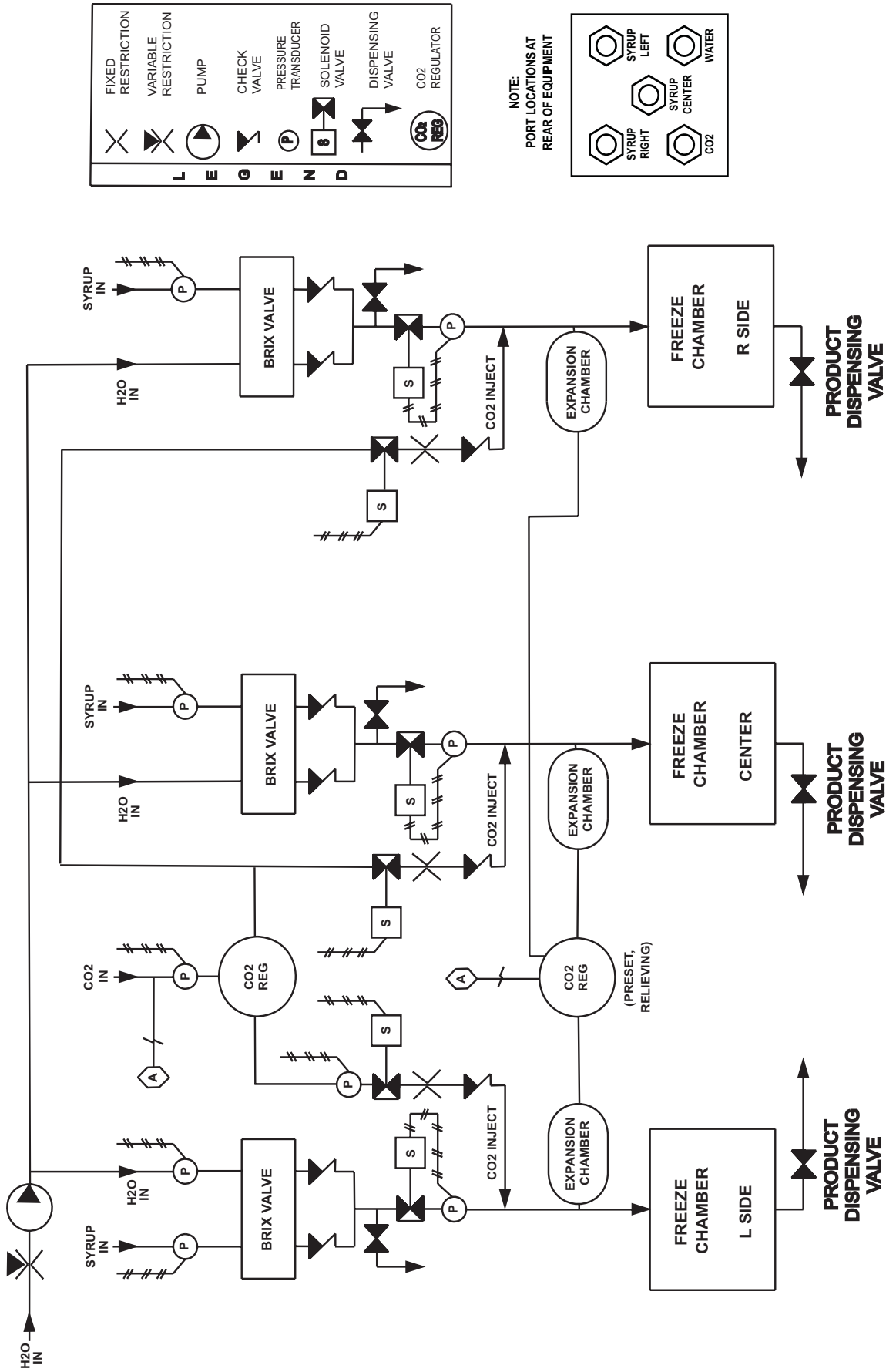

14.6 FLOW DIAGRAM/SCHEMATIC - FBD 564

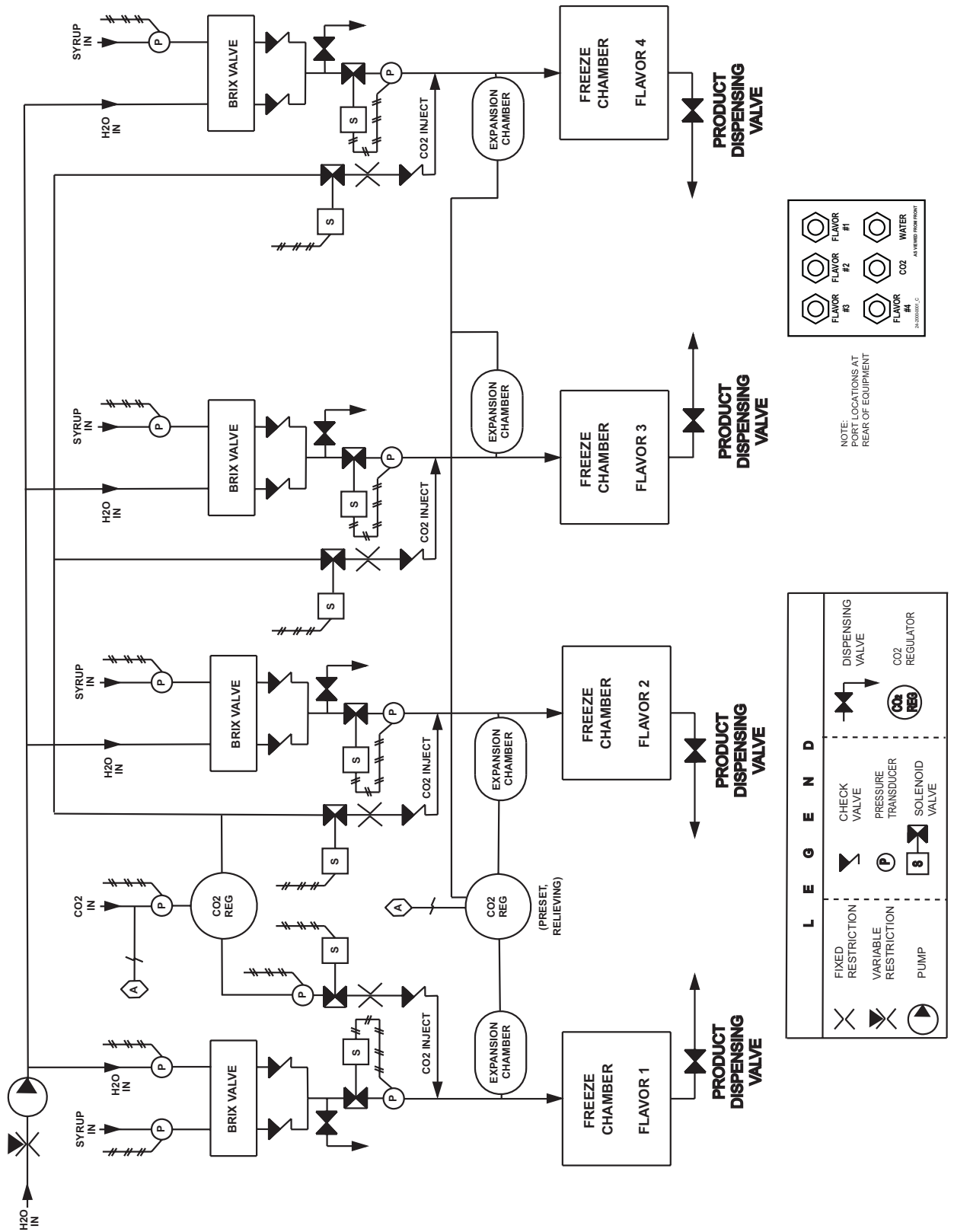

14.7 UPPER BOARD SCHEMATIC - FBD 562

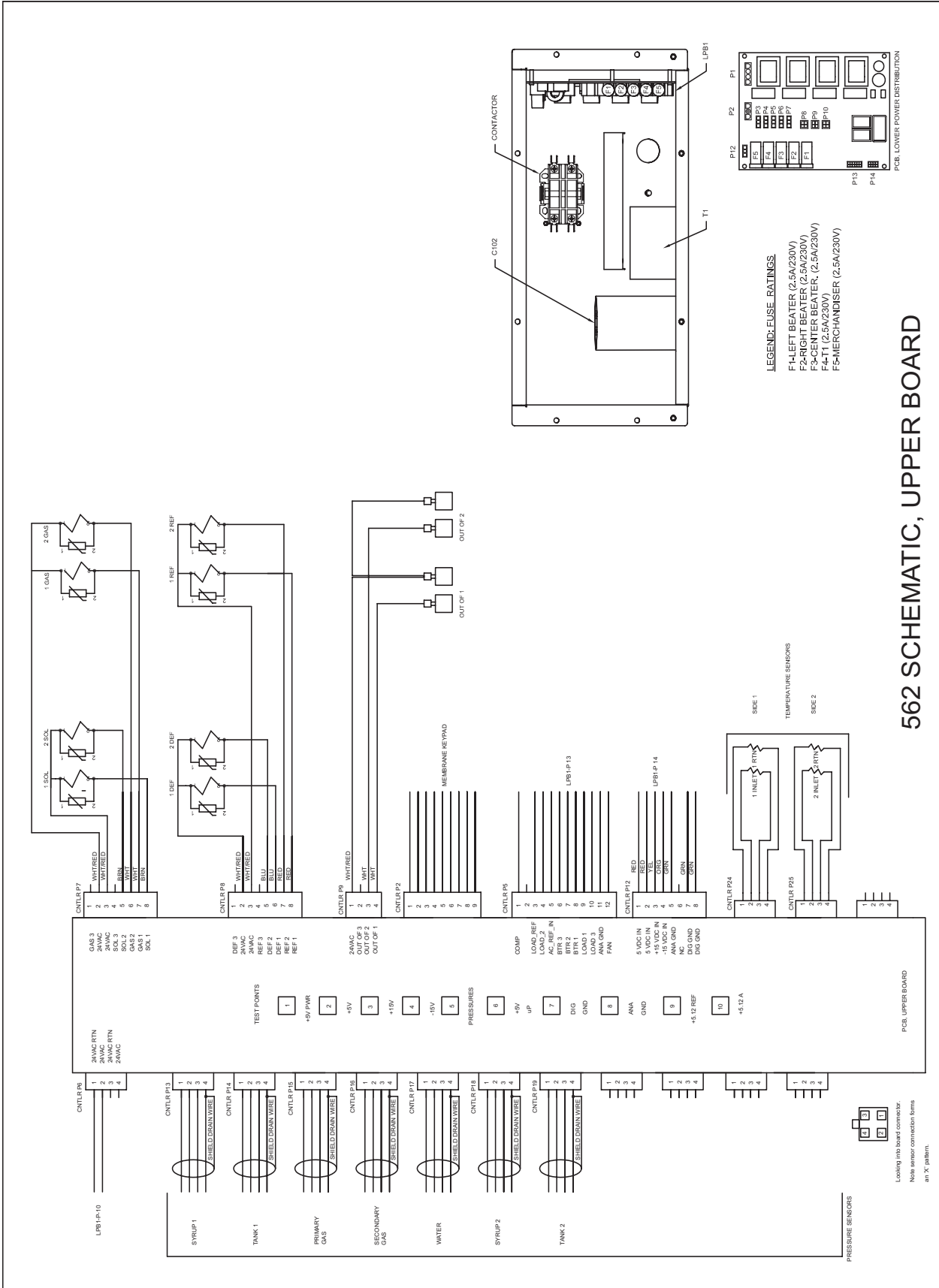

562 SCHEMATIC, UPPER BOARD

14.8 LOWER BOARD SCHEMATIC - FBD 562

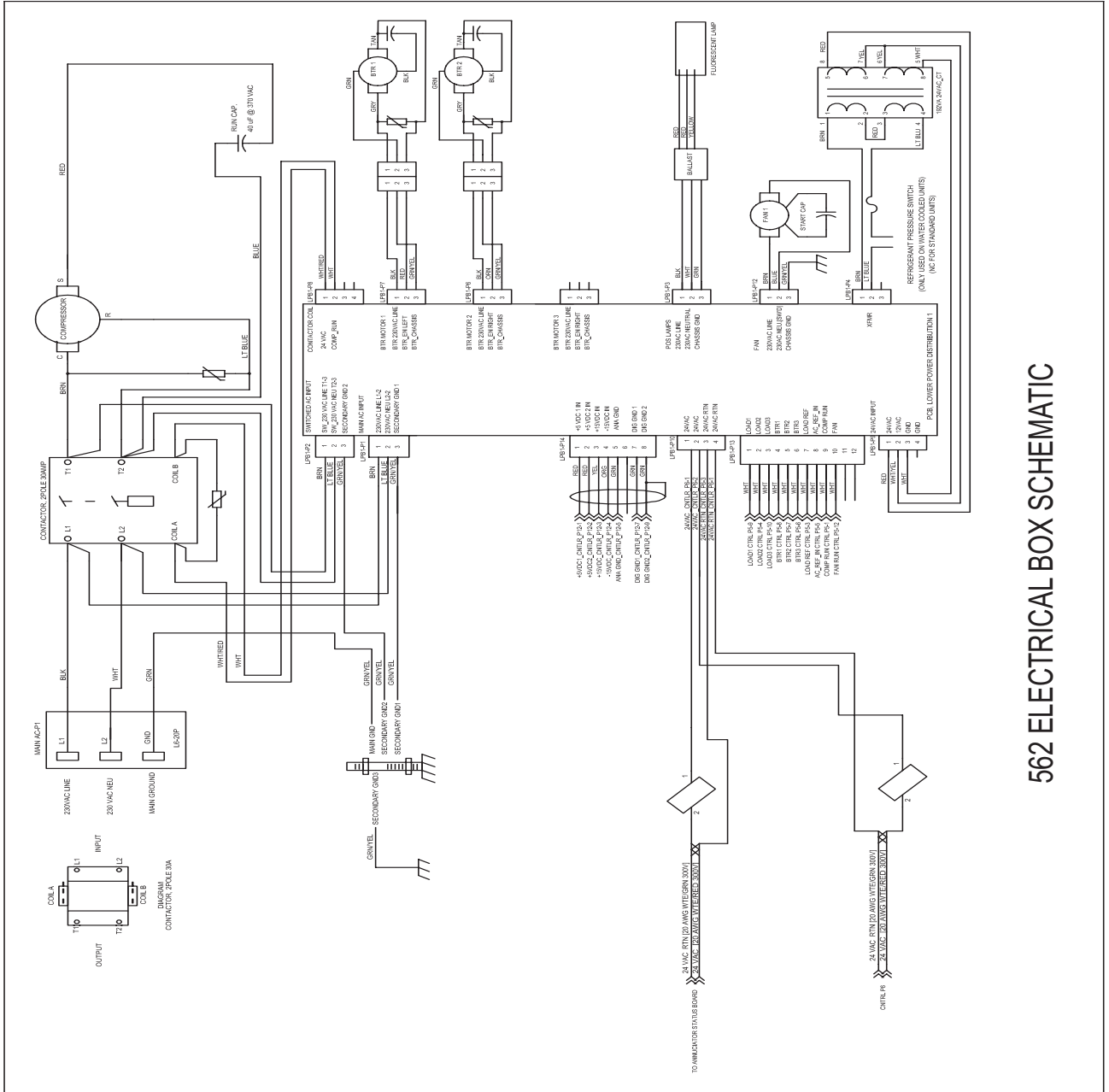

562 ELECTRICAL BOX SCHEMATIC

14.9 UPPER BOARD SCHEMATIC - FBD 563

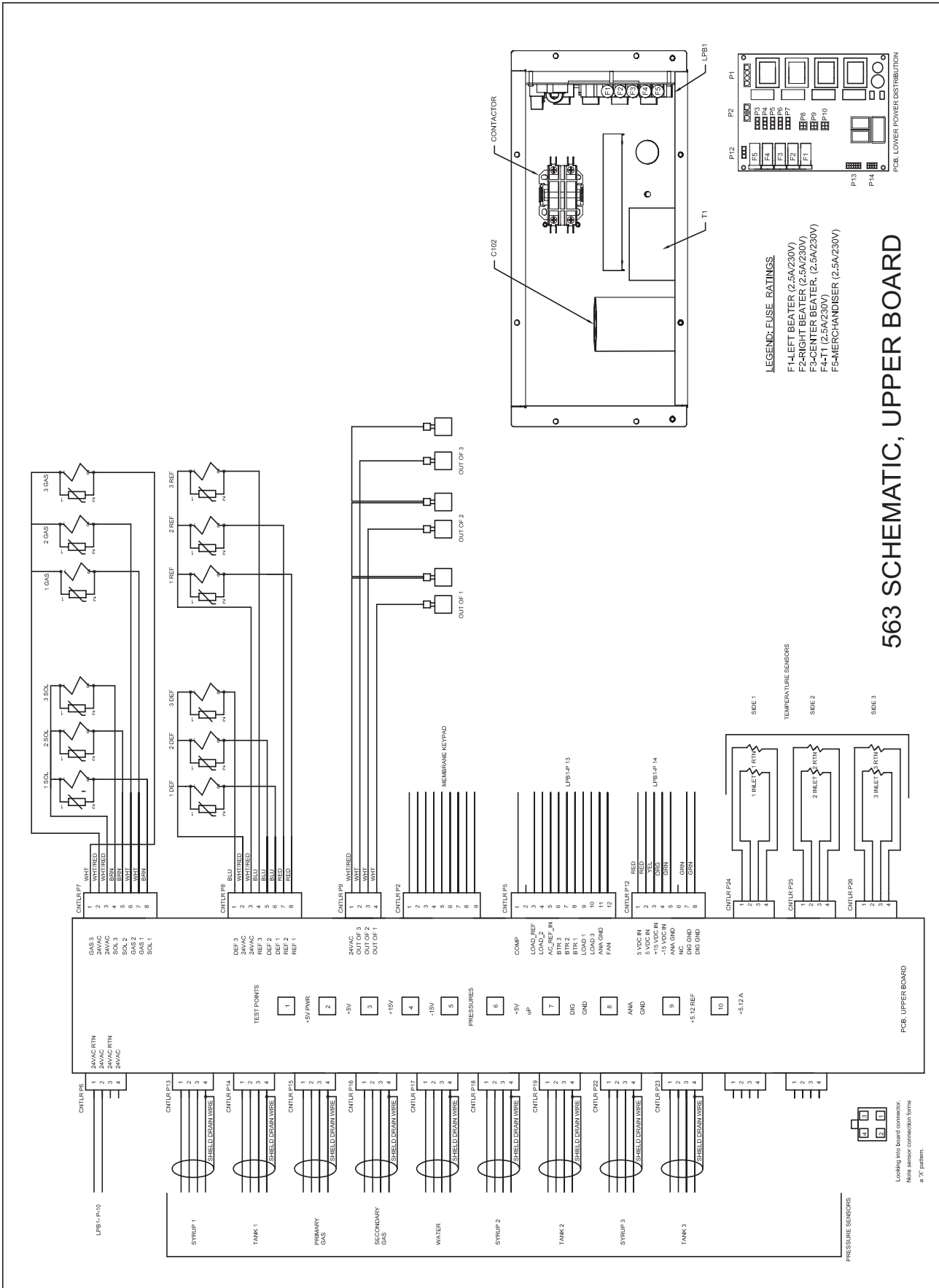

14.10 LOWER BOARD SCHEMATIC - FBD 563

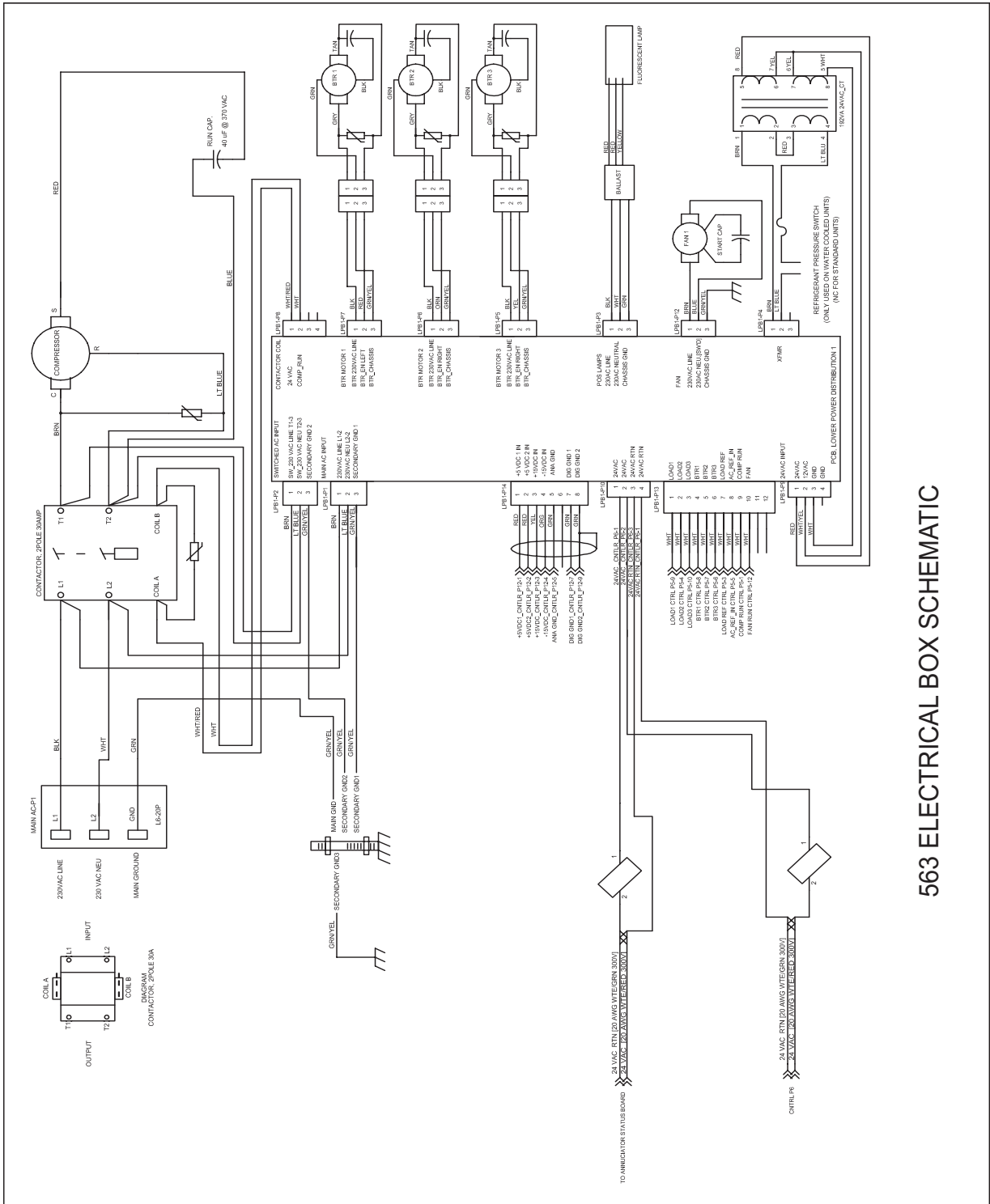

563 ELECTRICAL BOX SCHEMATIC

14.11 UPPER BOARD SCHEMATIC - FBD 564

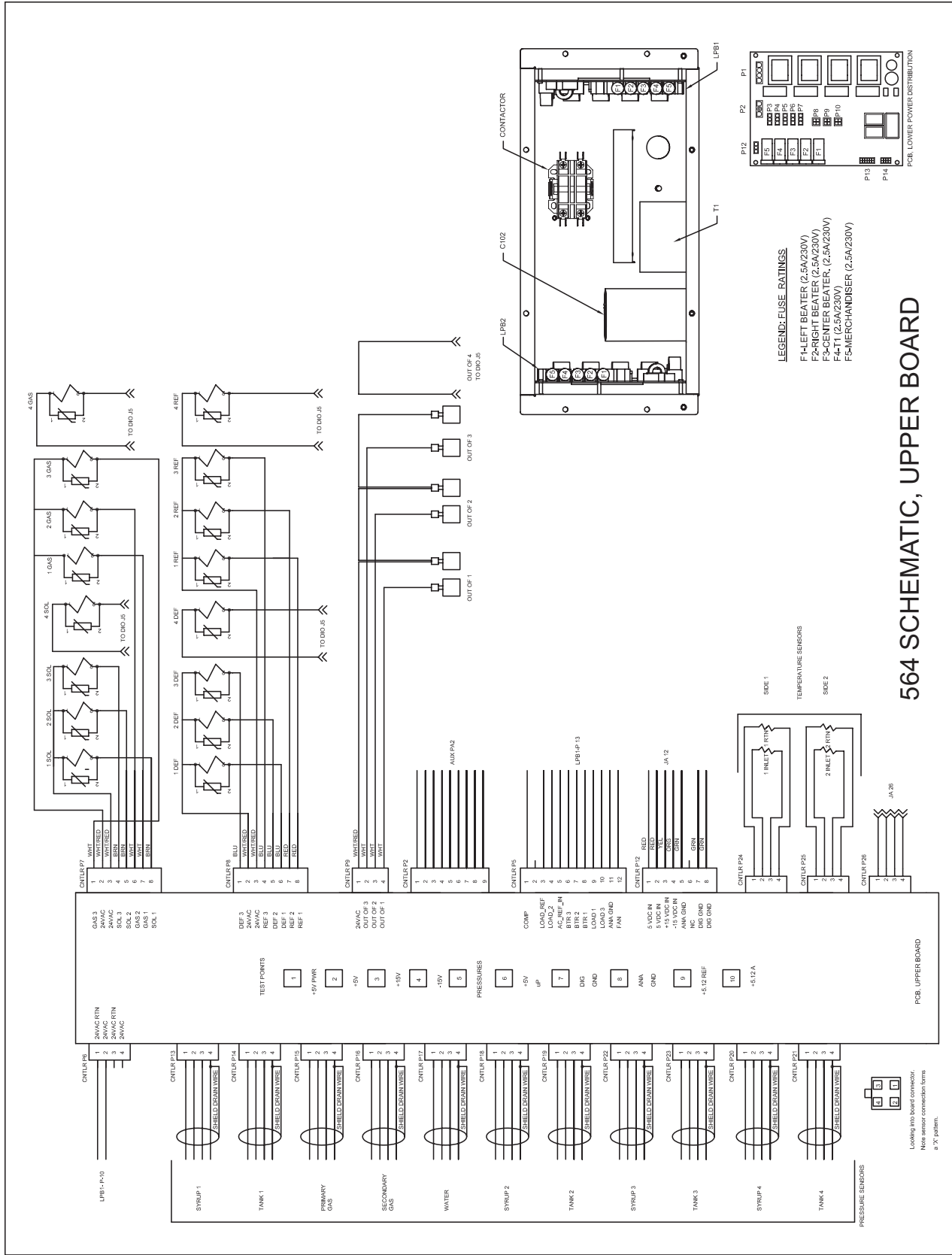

564 SCHEMATIC, UPPER BOARD

14.12 LOWER BOARD SCHEMATIC - FBD 564

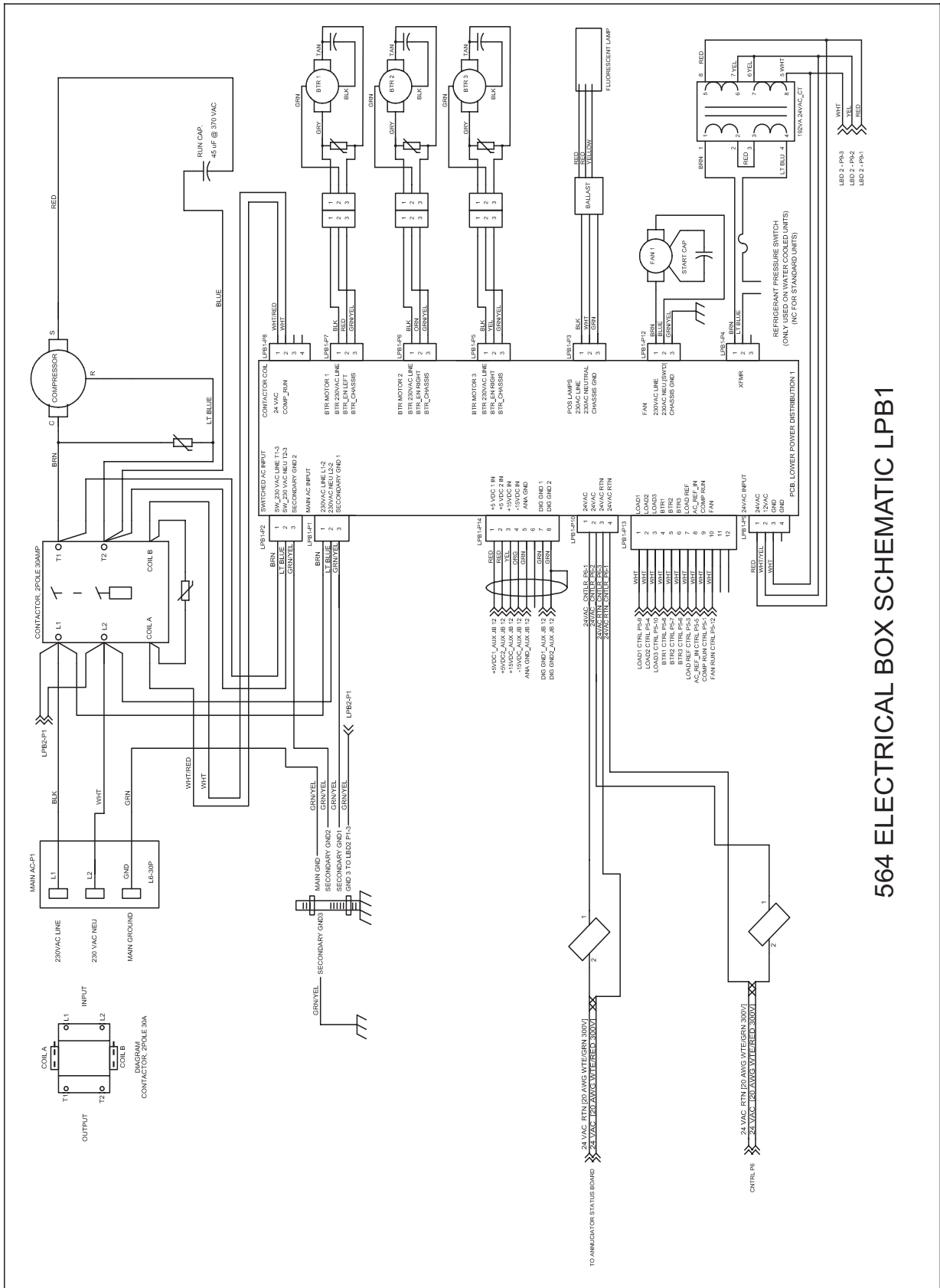

564 ELECTRICAL BOX SCHEMATIC LPB1

14.13 LOWER BOARD SCHEMATIC (INCLUDES AUXILIARY BOARD AND DIO BOARD) - FBD 564

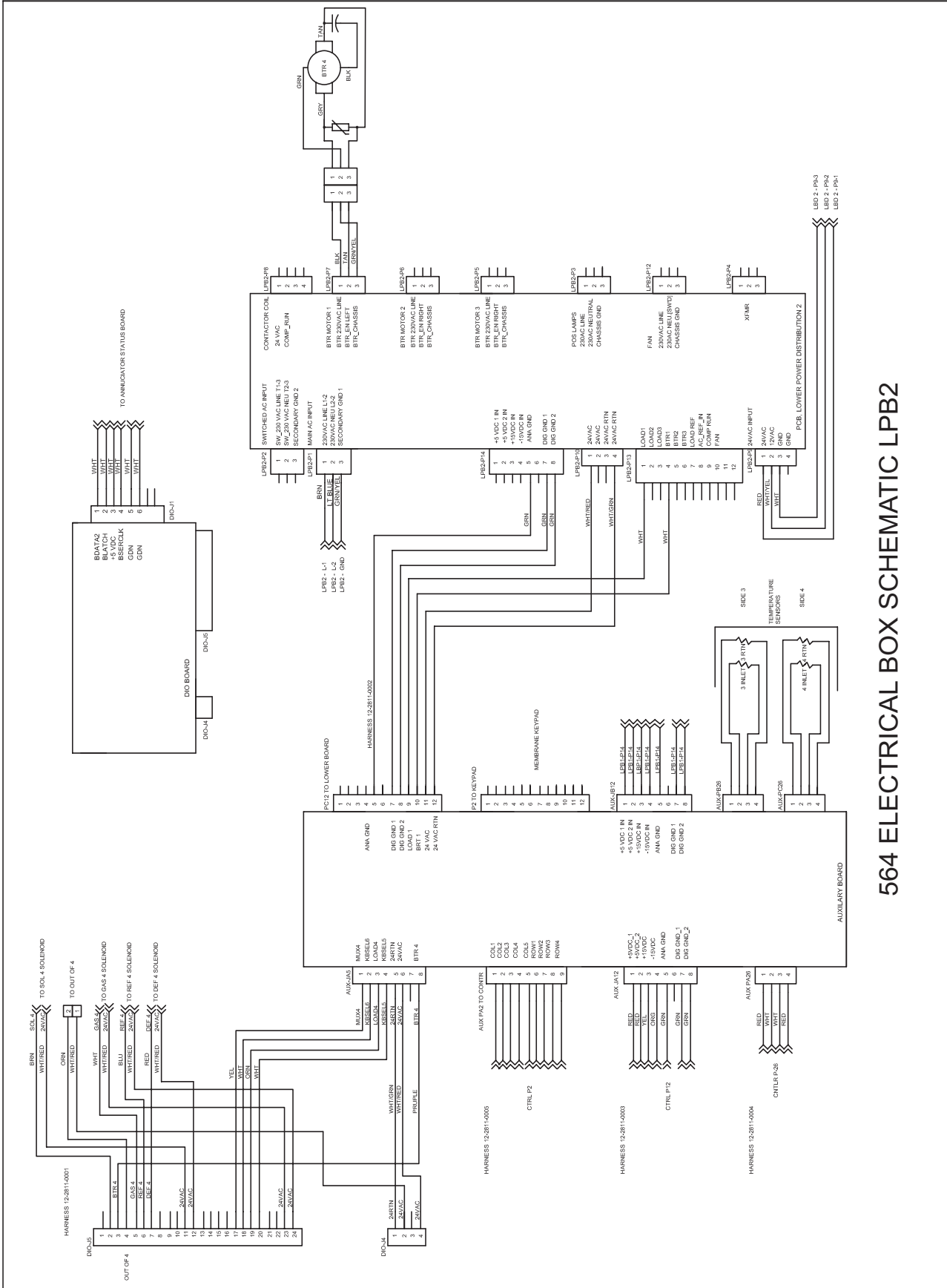

564 ELECTRICAL BOX SCHEMATIC LPB2

THIS PAGE INTENTIONALLY LEFT BLANK

NOTES:



Frozen Beverage Dispensers
EVERYONE LOVES FROZEN™

FBD Partnership, LP

- P.O. BOX 18597 • SAN ANTONIO, TX 78218 USA •
- 210-637-2800 • FAX 210-637-2844 • www.fbdfrozen.com •
- FBD TECHNICAL SUPPORT • 1-866-323-2777 •
- TECHNICAL SUPPORT FAX 1-210-637-2832 •

Please contact FBD Technical Support at 1-866-323-2777 for assistance.

Please refer to the FBD web site (www.fbdfrozen.com) for information relating to FBD Installation, Operation and Service Manuals, Instruction Sheets, Technical Bulletins, Service Bulletins, etc.