



# CAFE Series Airpot/ Thermal Decanter Pourover Coffee Brewing System



## READ AND SAVE THESE INSTRUCTIONS

**NOTICE TO INSTALLER:** Please leave this booklet with the machine.

Key Features/Specifications/System Requirements..... FS36

Important Safeguards..... IS2

Installation Instructions (General).....II4

Installation Instructions (Leveling, Electrical).....II5

Operating Instructions .....OI29

Cleaning Instructions (Brewers) ..... CI1

Cleaning Instructions (Thermal Dispensers) ..... CI9

Cleaning Instructions (De-liming) ..... CI12

Programming Guide ..... PG11

Rough-In Drawing..... RD42

Illustrated Parts/Recommended Parts ..... IP65

Illustrated Parts/Recommended Parts (Tank Assembly, Domestic)..... IP66

Illustrated Parts/Recommended Parts (Tank Assembly, Export) ..... IP192

Electrical Schematic (Domestic)..... ES68

Electrical Schematic (Export) ..... ES69

Troubleshooting Guide .....TG19

Product Warranty.....PW1

**Contact Information**

**Wilbur Curtis Co., Inc.**

6913 Acco Street | Montebello, CA 90640 US  
 Phone: 323-837-2300 | Toll Free: 800-421-6150  
 Email: [csrcassistance@wilburcurtis.com](mailto:csrcassistance@wilburcurtis.com) | Web: [www.wilburcurtis.com](http://www.wilburcurtis.com)

For the latest specifications and information go to [www.wilburcurtis.com](http://www.wilburcurtis.com)  
 Toll Free: 800-995-0417 | Monday - Friday 5:30 A.M. - 4:00 P.M. PT  
 Email: [techsupport@wilburcurtis.com](mailto:techsupport@wilburcurtis.com)

Due to continued product improvement, the products illustrated/photographed in this guide may vary slightly from the actual product.

## Key Features

- Pour-over operation – No plumbing required.
- Powerful heating element provides quick recovery for faster brewing.
- Large-volume water tank for greater brewing capacity.
- Space-saving design.
- Stainless steel construction with textured black powder coating.

## Specifications (Selected Models)

### Electrical Supply Requirements

MODEL #	DESCRIPTION	PHASE	VOLTS	AMPS	HEATING CONFIG	WIRE	WATTS	HERTZ	CAPACITY
CAFE0AP10A000	Pour-over Airpot Brewer	1 PH	120 V	12.1 A	1 x 1450 W	2W + G	1450 W	50/60 Hz	4.2 gal/hr [15.9 l/hr]
CAFE0PP10A000	Pour-over Pourpot Brewer	1 PH	120 V	12.1 A	1 x 1450 W	2W + G	1450 W	50/60 Hz	4.2 gal/hr [15.9 l/hr]

### EXPORT

CAFE0AP30Ax/ CAFE0AP31Ax	Pour-over Airpot Brewer, Export	1 PH	220-240 V	8.3-9.9 A	1 x 2000 W	2W + G (1/N/PE)	2000-2380 W	50/60 Hz	6.0 gal/hr [22.7 l/hr]
CAFE0PP30Ax/ CAFE0PP31Ax	Pour-over Pourpot Brewer, Export	1 PH	220-240 V	8.3-9.9 A	1 x 2000 W	2W + G (1/N/PE)	2000-2380 W	50/60 Hz	6.0 gal/hr [22.7 l/hr]

### Dimensions

MODEL #	HEIGHT	WIDTH	DEPTH	SHIP WEIGHT	SHIP CUBE
CAFE0AP10A000	24.97" [63.4 cm]	9.25" [23.5 cm]	17.93" [45.5 cm]	31.0 lbs [14.1 kg]	5.59 cu. ft. [0.16 m <sup>3</sup> ]
CAFE0PP10A000	17.61" [44.7 cm]	9.25" [23.5 cm]	17.93" [45.5 cm]	23.0 lbs [10.4 kg]	3.92 cu. ft. [0.11 m <sup>3</sup> ]

### EXPORT

CAFE0AP30Ax/ CAFE0AP31Ax	24.97" [63.4 cm]	9.25" [23.5 cm]	19.00" [48.3 cm]	31.0 lbs [14.1 kg]	5.59 cu. ft. [0.16 m <sup>3</sup> ]
CAFE0PP30Ax/ CAFE0PP31Ax	17.61" [44.7 cm]	9.25" [23.5 cm]	19.00" [48.3 cm]	23.0 lbs [10.4 kg]	3.92 cu. ft. [0.11 m <sup>3</sup> ]

**Symbols**



This is the safety alert symbol. It is used to alert you to potential physical injury hazards. Obey all safety messages that follow this symbol to avoid possible injury or death.



**DANGER** - Indicates a hazardous situation which, if not avoided, will result in death or serious injury.



**WARNING** - Indicates a hazardous situation which, if not avoided, could result in death or serious injury.



**CAUTION** - Indicates a hazardous situation which, if not avoided, could result in minor or moderate injury.



**NOTICE** - Indicates a situation which, if not avoided, could result in property damage.



**IMPORTANT** - Provides information and tips for proper operation.



**SANITATION REQUIREMENTS**



**WARNING** - This product can expose you to chemicals including Acrylamide and Bisphenol A (BPA), which are known to the State of California to cause cancer and birth defects or other reproductive harm. For more information visit [www.P65Warnings.ca.gov](http://www.P65Warnings.ca.gov).

**Important Safeguards/Conventions**



**WARNING:**

- Make sure that this appliance is installed and grounded according to the INSTALLATION INSTRUCTIONS by qualified personnel before attempting to use it. Failure to follow the INSTALLATION INSTRUCTIONS could result in personal injury or void the warranty.
- This appliance is designed for commercial use. Any service other than cleaning and preventive maintenance should be performed by an authorized Wilbur Curtis service technician.
- To reduce the risk of fire or electric shock, DO NOT open the service panels. There are no user serviceable parts inside.
- Keep hands, arms and other items away from hot surfaces of the unit during operation.
- Clean the appliance and any dispensers completely before using them for the first time according to the CLEANING INSTRUCTIONS. Clean them regularly as instructed in the CLEANING INSTRUCTIONS.
- Use this appliance only for its intended use, brewing/dispensing hot and/or cold beverages/water.
- This appliance is not intended for use by persons (including children) with reduced physical, sensory or mental capabilities or lack of experience and knowledge, unless they have been given supervision or instruction concerning use of the appliance by a person responsible for their safety. Children should be supervised to ensure that they do not play with the appliance.
- Avoid spillage onto the power (mains) connector.

## CE Requirements

- This appliance must be installed in locations where it can be overseen by trained personnel.
- For proper operation, this appliance must be installed where the temperature is between 5°C to 35°C.
- This appliance is not suitable for outdoor use.
- This appliance shall not be tilted more than 10° for safe operation.
- An electrician must provide electrical service as specified in conformance with all local and national codes. For safe use, an all-pole disconnection must be incorporated into the fixed wiring in accordance with the wiring rules outlined in clause 7.12.2 of IEC 60335 for meeting the minimum electrical safety of this standard.
- This appliance must not be cleaned by water jet.
- This appliance can be used by persons aged from 18 years and above if they have been given supervision or instruction concerning use of the appliance in a safe way and if they understand the hazards involved.
- Keep the appliance and its cord out of reach of children aged less than 18 years.
- Appliances can be used by persons 18 years and above with reduced physical, sensory or mental capabilities or lack of experience and knowledge if they have been given supervision or instruction concerning use of the appliance in a safe way and understand the hazards involved.
- Children under the age of 18 years should be supervised to ensure they do not play with the appliance.
- If the power cord is ever damaged, it must be replaced by the manufacturer or authorized service personnel with a special cord available from the manufacturer or its authorized service personnel in order to avoid a hazard.
- Machine must not be immersed for cleaning.
- Cleaning and user maintenance shall not be made by children unless they are older than 18 years and supervised.
- This appliance is intended to be used in household and similar applications such as:
  - staff kitchen areas in shops, offices and other working environments;
  - by clients in hotels, motels and other residential type environments;
  - bed and breakfast type environments.
- This appliance not intended to be used in applications such as:
  - farm houses
- Access to the service areas permitted by Authorized Service personnel only.
- The A-Weighted sound pressure level is below 70 dBA.

## Disposal of Equipment

- This product contains plastic, metal and electronic components and is considered e-waste. At the end of its life, this product must not be disposed of in normal household waste but can be instead delivered to a collection point for recycling electric and electronic appliances, consult with the local municipality for proper disposal guidelines.



**WARNING:** Improper electrical connection may result in an electric shock hazard. This appliance must be properly grounded.



**WARNING:** If installation of a power plug is required, it must be installed only by a qualified installer.



**IMPORTANT:** Observe all governing codes and ordinances.

## Installation Instructions

### Installation Requirements

- A secure surface capable of supporting the weight of the appliance.
- For appliances without an attached cord set: Appropriately sized, UL listed, grounding type power cable to meet the electrical specifications for the unit. If you have questions about the correct cable size and length, consult a qualified installer. For appliances that will be hard wired to a junction box, the power cable must be long enough so that the brewer can be moved for cleaning underneath.
- A grounded electrical connection to an electrical circuit that meets the electrical specifications of the appliance (see **SPECIFICATIONS**). The circuit must be protected by the appropriate sized circuit breaker. If you are not certain that the existing circuit meets the requirements for your brewer, consult a licensed electrician.

**NOTICE** - This brewer is shipped with the thermostat turned ON. DO NOT plug in the brewer before pouring 3 pots/192 oz. of water into the opening as instructed below; damage to the heating element and/or thermostat will result.

**Installation**

**Leveling**

**WARNING:** Use the leveling legs to level the brewer only. Do not use them to adjust brewer height. Do not extend them higher than necessary.

- 1 Position the brewer on the countertop near an electrical outlet that meets the **SPECIFICATIONS**. Level the brewer left to right and front to back by turning the bottom of the legs.

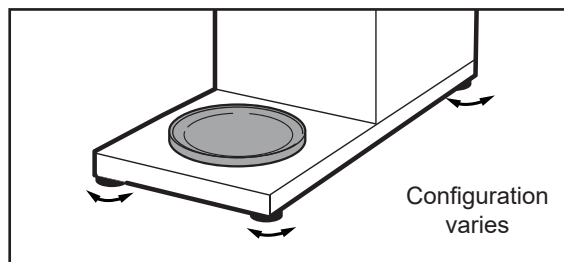

**Connecting the Brewer Power Plug - Export Units**

- 2 Connect the appropriate type of grounded power plug to the end of the power cord coming from the back of the unit.

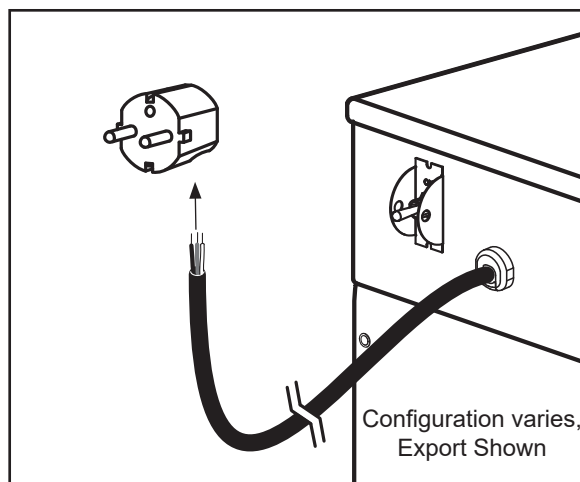

**Prepare the Brewer for Use**

- 3 Place an empty glass decanter on the warmer deck, under the spray head.
- 4 Insert the empty brew basket into the brew rails of the brewer, below the control panel.
- 5 Fill the water tank by slowly pouring room temperature water through the opening on the top cover, until water starts running in a steady stream from the brew basket. It takes approximately three pots or 192 ounces to fill the tank, indicated by water coming out of the brew basket.



**Powering Up the Brewer**



**WARNING:** Connect the power cords only to the appropriate type and size electrical outlet. If the electrical outlet is not compatible with the power cords, have it upgraded by a licensed electrician. Do not modify the power plug. Do not use an extension cord. Do not use a power cord/plug that is damaged.



**IMPORTANT:** When operating the brewer at elevations higher than 4000 feet (1200 meters), have a qualified installer adjust the thermostat inside the unit. See the *PROGRAMMING GUIDE* section.

- 6 Connect the power cord to the electrical outlet.
- 7 Make sure that the circuit breaker supplying power to the brewer is on.
- 8 Some brewers are equipped with a main power switch on the back or front of the unit. Turn it to the ON position.
- 9 Depending on the water temperature and the electrical specifications, the water tank typically requires 20 to 30 minutes to reach operating temperature. When the water has heated, the **READY TO BREW** light will come on.

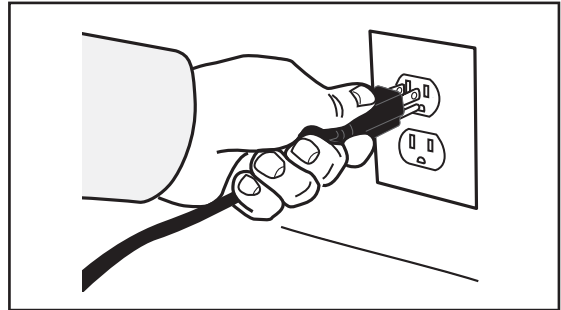

Configuration varies,  
Export Shown

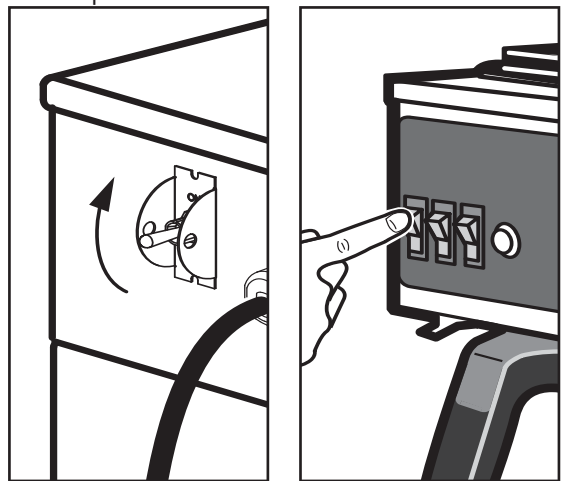

**Power Switch (some units)**

## Brewing Instructions



**WARNING - TO AVOID SCALDING, AVOID SPLASHING.** The brew basket contains hot coffee grounds. Keep body parts clear of the brewer during brewing. Allow the brew basket to drain before removing it. Be careful not to pour more water into the pourover opening that will fill the container below.



**NOTICE** - Before plugging the brewer in for the first time, fill the water tank according to the *INSTALLATION INSTRUCTIONS* section. Connecting the power without a full water tank will damage the brewer.

### Before Brewing:

- A pitcher with a volume less than or equal to the volume of the airpot/thermal dispenser is required for brewing.
- Some water in the water tank may evaporate if the brewer is left on for long periods of time. When this occurs, pour in enough water to refill the tank (until water comes out of the spray head) before brewing.

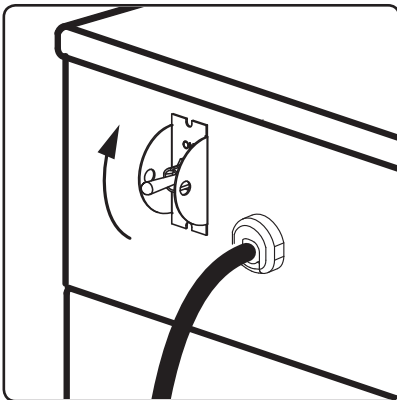

- 1 The brewer should be plugged in and the "READY TO BREW" light should be lit. On units with a rear toggle switch, make sure it is in the ON position.

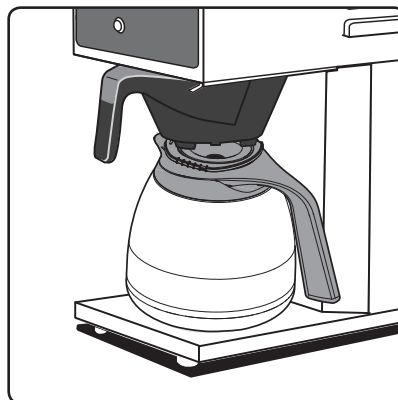

- 2 Center an empty airpot or thermal decanter under the brew basket.

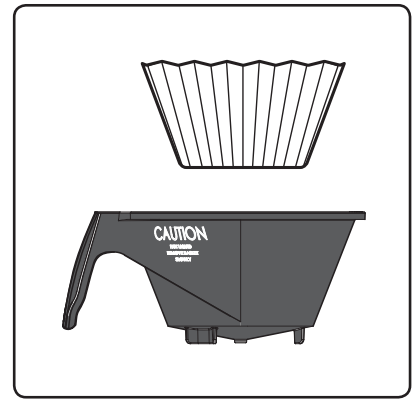

- 3 Insert a clean paper filter into the brew basket.

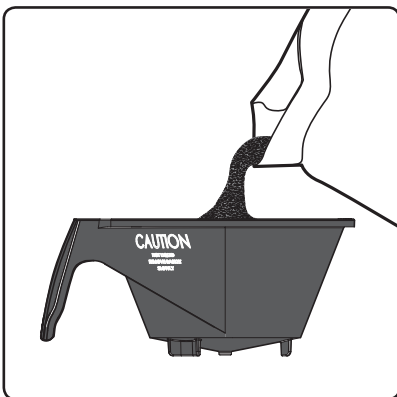

- 4 Fill the brew basket with the proper amount of ground coffee. Level the coffee in the filter.

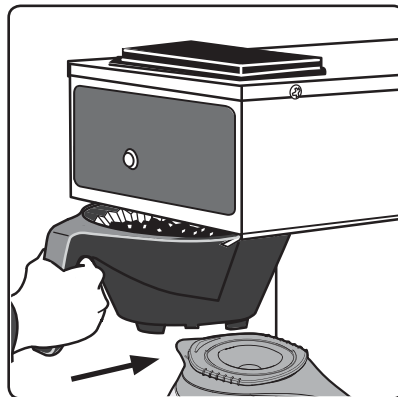

- 5 Slide the filled brew basket into the brew rails under the control panel. Slide it all the way back until it stops.

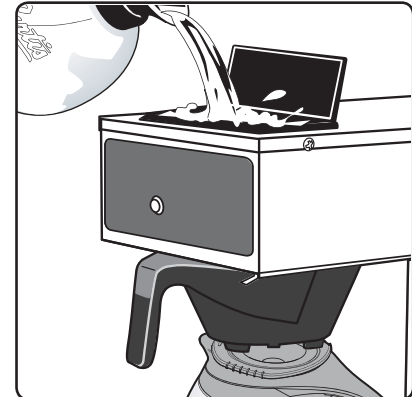

- 6 Using a pitcher, pour room temperature water into the pourover opening on the top. DO NOT overfill. The brew time will be about three minutes.



**WARNING: HOT SURFACES** - To avoid injury, allow the brewer and dispenser(s) to cool before cleaning.



**NOTICE** - Do not use cleaning liquids, compounds or powders containing chlorine (bleach) or corrosives. These products promote corrosion and will damage the finishes. **USE OF THESE PRODUCTS WILL VOID THE WARRANTY.**

---

### Cleaning The Brewer - Daily

---



**WARNING:** DO NOT immerse the brewer in water or any other liquid.

---

**The brewer should be OFF.** Turn the brewer off by flipping the rear toggle switch to the OFF position.

- 1 Remove the dispenser(s). Wipe exterior brewer surfaces with a damp cloth to remove spills and debris.
- 2 Remove the brew basket(s) and clean them in a mild detergent solution. Use a soft bristled brush for hard to clean areas. Rinse with clean water, then dry.
- 3 Wipe the spray head area with a cloth soaked in a mild detergent solution. Rinse with a cloth soaked with clean water removing any residual detergent. Use a clean, soft cloth to dry.
- 4 Dump out the drip tray(s) (if applicable). Rinse with clean water, then dry with a soft, clean cloth.

### Cleaning The Brewer - Weekly

**The brewer should be OFF.** Turn the brewer off by flipping the rear toggle switch to the OFF position.

- 1 Remove the spray head(s), unscrewing counterclockwise from the dome plate.
- 2 Thoroughly clean and rinse the dome plate area.
- 3 Clean the brew basket rails with a brush soaked with a mild detergent solution. Rinse the area with a cloth soaked with clean water, removing any residual detergent.
- 4 Dry the area with a soft, clean cloth.
- 5 Reattach the spray head(s).

## Cleaning the Airpot/Pour Pot (Daily)



**WARNING:** DO NOT immerse the airpot/pour pot or lid assembly in water or any other liquid. Do not place the airpot/pour pot or lid in a dishwasher. Placing a airpot or pour pot in a dishwasher will void the warranty.

Start by preparing a mild solution of detergent and warm water. Remove the airpot/pour pot from the brewer and remove/open the lid. On airpots, remove the nozzle assembly. Rinse.

### Cleaning Airpots

- 1 Wash** - Wipe the exterior surfaces of the airpot and lid with a sponge soaked with the detergent solution to remove spills and debris. Fill the liner with the detergent solution. Use a sponge cleaning brush to clean inside. Clean the spout/siphon tube with the detergent solution.
- 2 Rinse** - Rinse the airpot and the spout/siphon tube with clean, warm water.
- 3 Sanitize** - Sanitize the interior of the airpot, the spout/siphon tube and the lid, using a commercial sanitizer suitable for food grade applications. Swab, brush or pressure spray the sanitizing solution according to the directions on the package.
- 4 Air Dry** - Turn the airpot and lid upside down. Allow all parts to air dry.

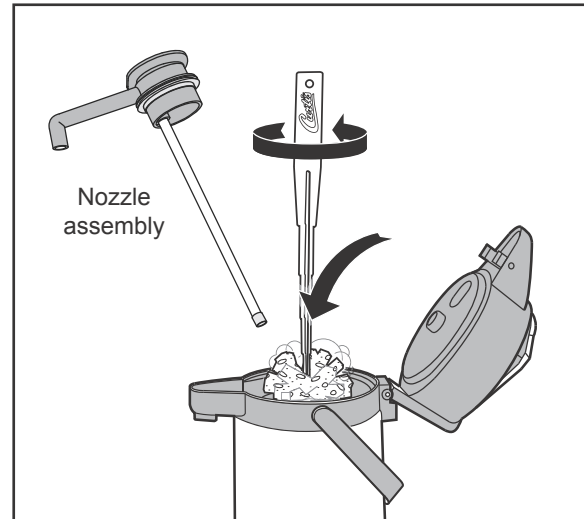

TLXA2201G000 shown. Appearance and size varies with model number.

### Cleaning Pour Pots

- 1 Wash** - Wipe the exterior surfaces of the pour pot and lid with a sponge soaked with the detergent solution to remove spills and debris. Fill the liner with the detergent solution. Use a sponge cleaning brush to clean inside.
- 2 Rinse** - Rinse the pour pot and the lid with clean, warm water.
- 3 Sanitize** - Sanitize the interior of the pour pot and the lid, using a commercial sanitizer suitable for food grade applications. Swab, brush or pressure spray the sanitizing solution according to the directions on the package.
- 4 Air Dry** - Turn the pour pot and lid upside down and allow to air dry.

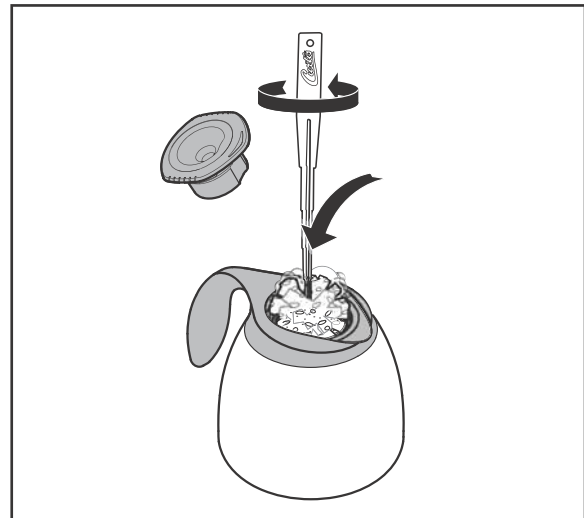

CLXP6401S100 shown. Appearance and size varies with model number.



**NOTE:** The stem on the bottom of TFT series pour pot lids have a built-in sensor used for the FreshTrac® feature. Keep this stem free from coffee oil build-up for proper operation. After cleaning, inverting the lid for 30 seconds resets the FreshTrac timer.

## De-liming Procedure\*



**NOTICE** - The deliming procedure must be performed by a qualified service technician.

The deliming spring, provided with the brewer, is for cleaning lime deposits from within the siphon tube.

- 1 Remove the spray head.
- 2 Insert spring into the siphon tube. Twist the spring clockwise as you push inward. Once past the bend in the tubing, you can slide it back and forth to remove hard lime deposits.

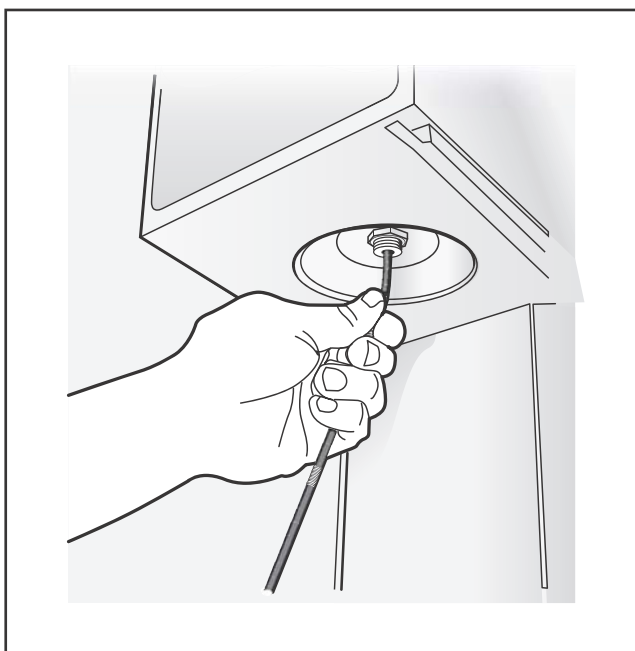

\* This procedure may need to be performed daily in areas with extremely hard water.

## Thermostat Adjustment



**WARNING** - The following procedures are to be performed only by a qualified installer or service technician.

The brewer is equipped with either an electronic or mechanical (capillary) type thermostat. The tank temperature (thermostat) adjustment procedure is different for each type.

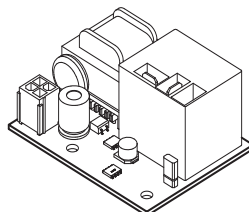

**Electronic Thermostat**

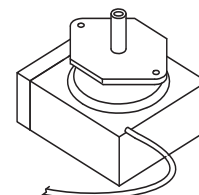

**Mechanical Thermostat**

### Electronic Thermostat

The electronic thermostat has two settings; 200°F (93°C) and 190°F (88°C). The factory default setting is 200°F. If operating the brewer at altitudes higher than 4000 feet (1200 m), set it to 190°F.

- 1 Unplug the brewer power cord.
- 2 Remove the back cover.
- 3 Locate the thermostat, attached to a bracket near the top of the compartment.
- 4 Locate the temperature setting jumper pins. It is labeled “200°F” on the printed circuit board.
- 5 When jumpered, the board is set to 200°F. When the jumper is removed, it is set to 190°F. When setting the thermostat to 190°F, slip the jumper over (only) one of the pins, in the event that the board needs to be changed back.
- 6 Replace the back cover and reconnect power.

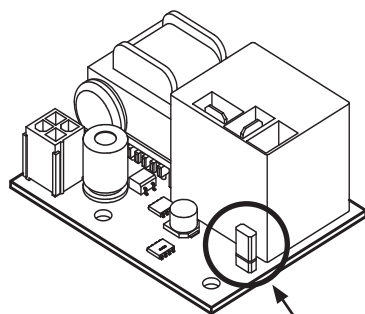

Jumper in 200°F position (default)

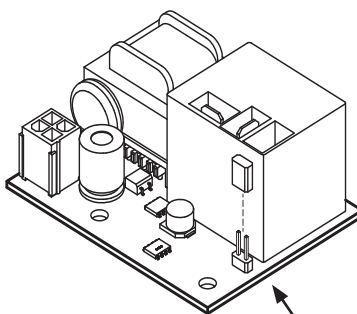

Remove jumper to change setting

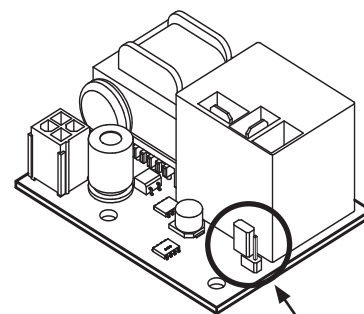

Jumper in 190°F position

continued...

## Mechanical Thermostat

The mechanical thermostat has an adjustment screw used to set the temperature. The factory default setting is 200°F (93°C). When operating the brewer at higher elevations, reduce the operating temperature by 2°F for each 1000 feet of elevation above 4000 feet (1200 m).

- 1 Unplug the brewer power cord.
- 2 Remove the top cover.
- 3 Locate the thermostat, attached to a bracket near the back of the compartment.
- 4 Using a flat blade screwdriver, turn the adjustment screw on top of the thermostat counterclockwise to lower the temperature. 1/8 of a turn on the screw, lowers the temperature approximately 30°F (17°C). When the screw is turned all the way clockwise, the thermostat is set to 200°F.
- 5 Replace the back cover and reconnect power.
- 6 If the brew temperature of the water is too cool, readjust following the above steps, keeping in mind that too high a temperature setting at higher altitudes may cause the water in the tank to boil.

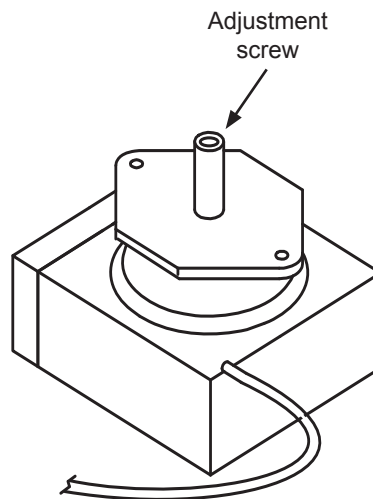

CAFE0AP Series Coffee Brewers

---

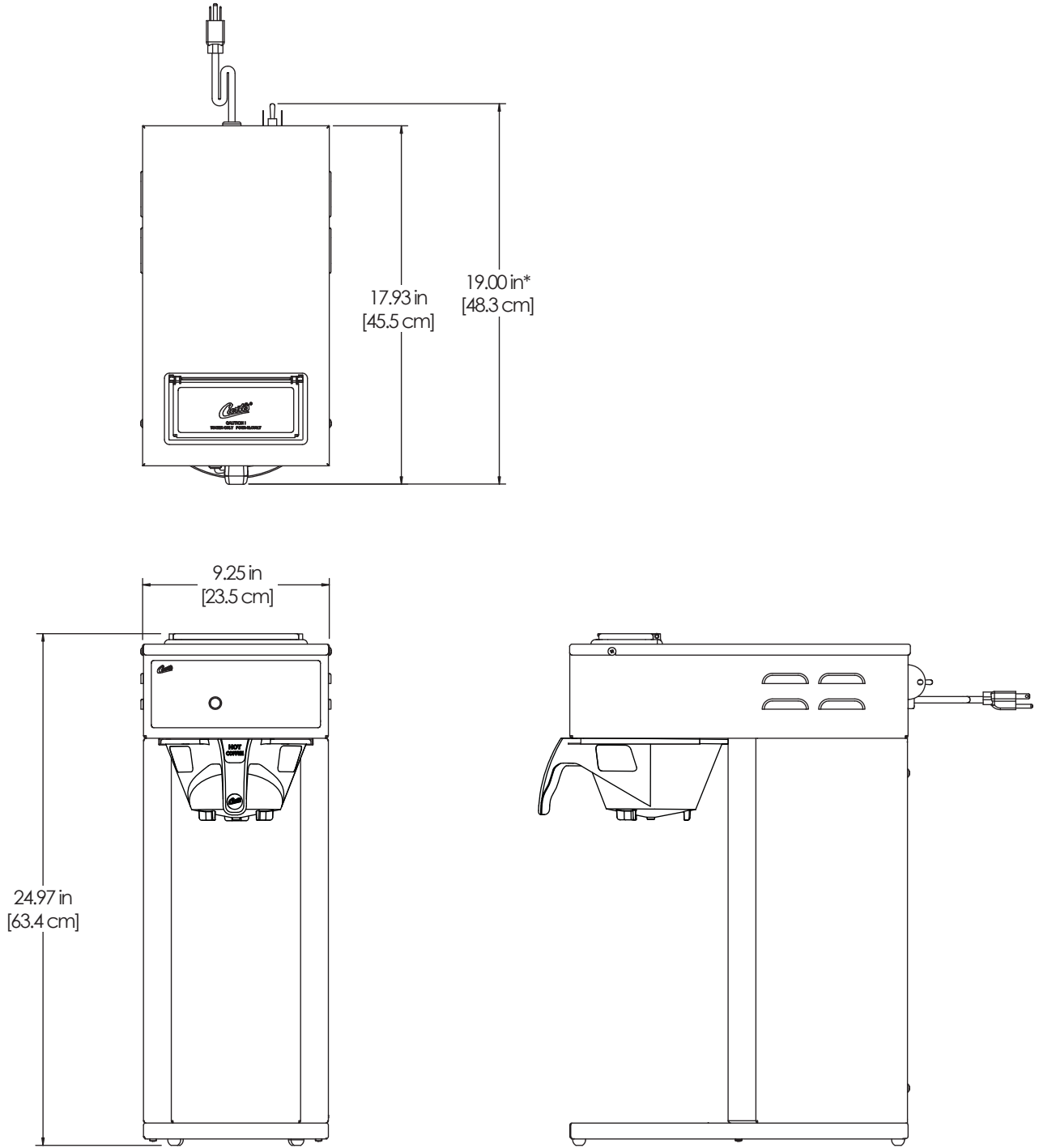

\* Units equipped with a toggle switch only

CAFE0PP Series Coffee Brewers

---

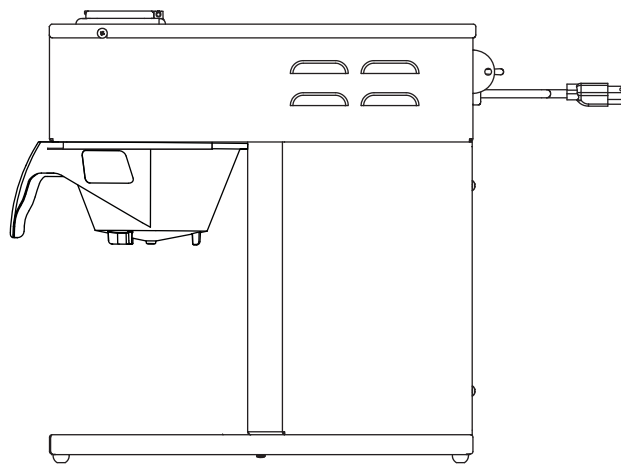
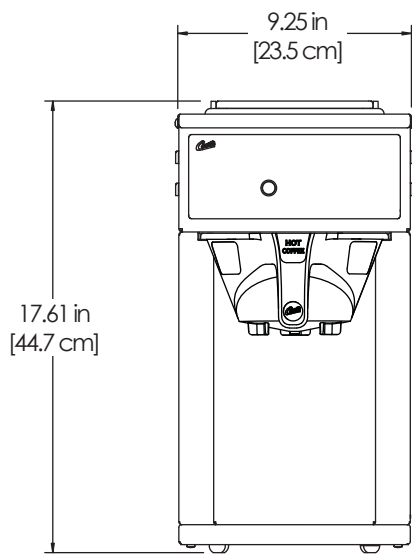
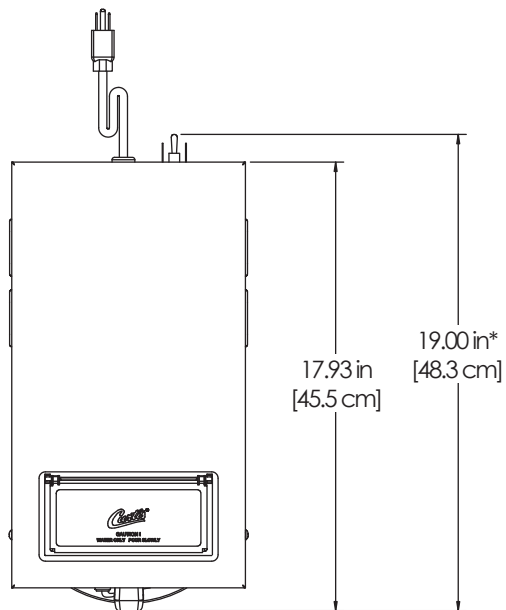

\* Units equipped with a toggle switch only

CAFE0AP, CAFE0PP - Main Chassis - Exploded View

Chassis configuration varies with model

Water tank assemblies:  
 - Domestic, see section IP66  
 - Export, see section IP192

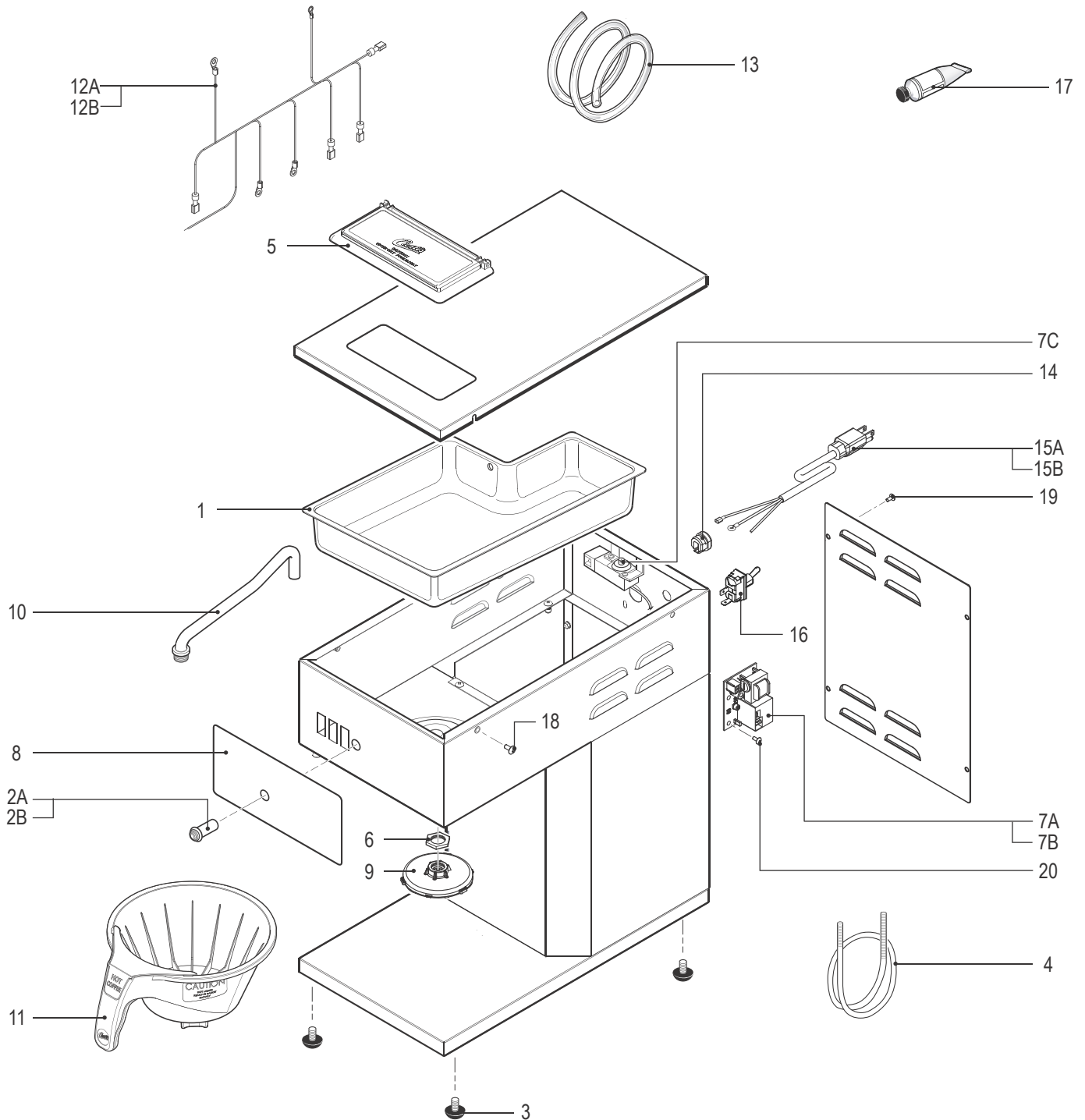

## CAFE0AP, CAFE0PP - Main Chassis - Parts List

ITEM #	PART #	DESCRIPTION
1	<a href="#">WC-54121</a>	PAN, POUR CAFÉ
2A	<a href="#">WC-207</a> <sup>1,3</sup>	LIGHT, BREW 115V GREEN
2B	<a href="#">WC-208</a> <sup>2,4</sup>	LIGHT, BREW 250V GREEN
3	<a href="#">WC-3502</a>	LEG, 8-32 STUD SCREW BUMPER
4	<a href="#">WC-3645</a>	SPRING, DELIMITING .041 X 20" GALVANIZED WIRE HARD DRAWN
5	<a href="#">WC-54118</a>	TRAY, ASSY CAFE POUR OVER
6	<a href="#">WC-4213-P</a>	NUT, 5/8 LOCK PLATED
7A	<a href="#">WC-735-101K</a> <sup>1,3*</sup>	KIT, CONTROL MODULE RETROFIT
7B	<a href="#">WC-735-101</a> <sup>1,3*</sup>	THERMOSTAT, TEMPERATURE CONTROL 120VAC POUROVER CAFE
7C	<a href="#">WC-504</a> <sup>2,4</sup>	THERMOSTAT, CAPILLARY SPST 250V 25A GEM
8	<a href="#">WC-39371</a>	LABEL, SW PANEL CAFÉ AP CURTIS
9	<a href="#">WC-29025</a>	SPRAYHEAD, PURPLE ADVANCE FLOW
10	<a href="#">WC-29054</a>	TUBE, W/A CAFE POUR OVERS

<sup>1</sup> CAFE0AP10A000, <sup>2</sup> CAFE0AP30A000, <sup>3</sup> CAFE0PP10A000, <sup>4</sup> CAFE0PP30A000

\* **IMPORTANT:** The mounting location of the temperature control module was changed on newer units to increase reliability. If replacing a control module that is mounted near the top of the water tank, order item 7A (includes parts and instructions for installing the replacement module in the new location). If the module is mounted just above the base of the chassis, order item 7B.

ITEM #	PART #	DESCRIPTION
11	<a href="#">WC-3621-101</a>	BREW CONE, NON-METAL UNIVERSAL (WITH SPLASH POCKET)
12A	<a href="#">WC-13301-101</a> <sup>1,3</sup>	HARNESS ASSY, CAFE AP 120V FOR ELECTRONIC THERMOSTAT
12B	<a href="#">WC-13301</a> <sup>2,4</sup>	HARNESS ASSY, CAFÉ AP 220V
13	<a href="#">WC-5310</a>	TUBE, 5/16 ID x 1/8W SILICONE GEN USE
14	<a href="#">WC-1408</a>	CORD GRIP, 7/8" O.D.
15A	<a href="#">WC-1200</a> <sup>1,3</sup>	CORD, 14/3 SJTO 6' BLK W/PLUG
15B	<a href="#">WC-1231-103</a> <sup>2,4</sup>	CORD, 2.5 mm <sup>2</sup> PRE-CUT W/ CONNECTORS
16	<a href="#">WC-103</a> <sup>2,4</sup>	SWITCH, TOGGLE NON-LIT DPST 25A 125/250VAC RESISTIVE
17	<a href="#">WC-5231</a>	COMPOUND, HEAT SINK 5OZ
18	<a href="#">WC-4426</a>	SCREW, 8-32x3/8 PH HEAD TRUSS
19	<a href="#">WC-4442</a>	SCREW, 8-32x3/8 PH HD TRUSS BLACK
20	<a href="#">WC-4514</a>	SCREW, 8-32x3/8 PAN HEAD PH SS

## CAFE0AP, CAFE0PP - Main Chassis - Recommended Parts to Stock

ITEM #	PART #	DESCRIPTION
9	<a href="#">WC-29025</a>	SPRAYHEAD, PURPLE ADVANCE FLOW
13	<a href="#">WC-5310</a>	TUBE, 5/16 ID x 1/8W SILICONE GEN USE
16	<a href="#">WC-103</a>	SWITCH, TOGGLE NON-LIT DPST 25A 125/250VAC RESISTIVE

ITEM #	PART #	DESCRIPTION
17	<a href="#">WC-5231</a>	COMPOUND, HEAT SINK 5OZ

WC-54117 - Tank Assembly

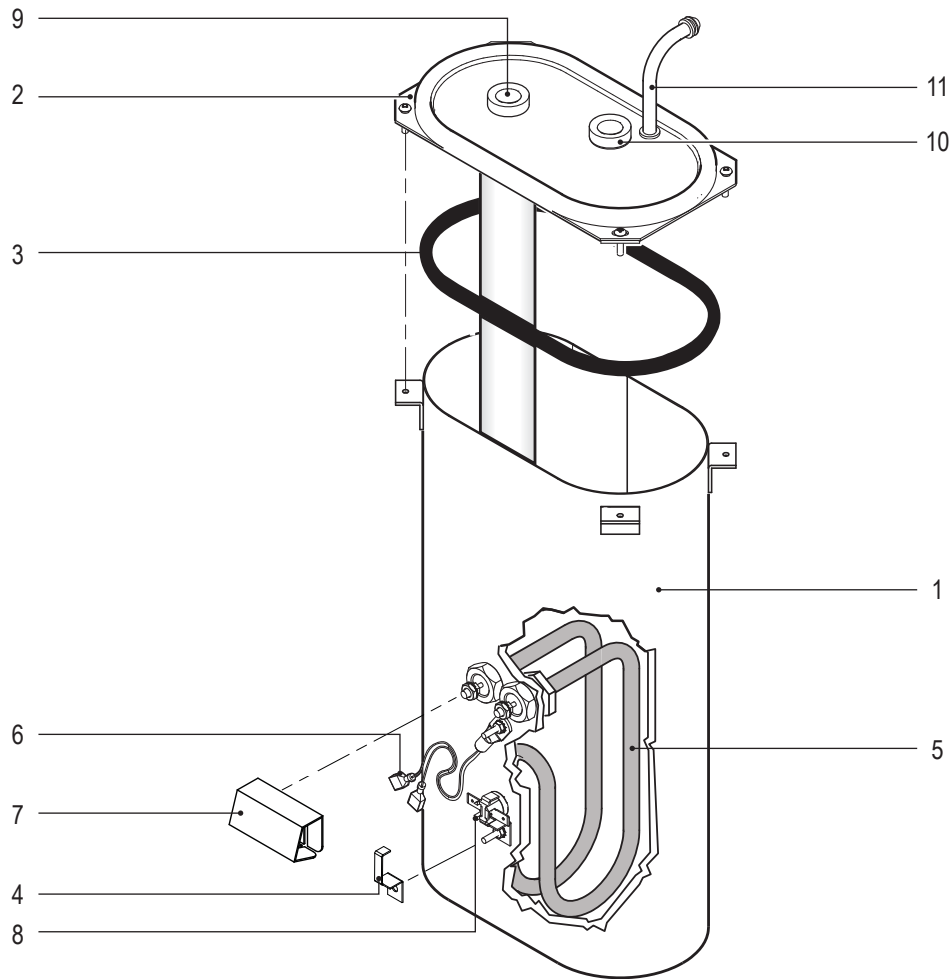

WC-54117 - Tank Assembly - Parts List

ITEM #	PART #	DESCRIPTION
1	<a href="#">WC-54117</a>	TANK, COMPLETE 1450W 120V CAFÉ
2	<a href="#">WC-54125-101</a>	COVER, W/A HEATING TANK CAFÉ
3	<a href="#">WC-43062</a>	GASKET, TANK LID
4	<a href="#">WC-5418</a>	CLIP, RESET THERMOSTAT GEN USE
5	<a href="#">WC-917-04</a>	ELEMENT, HEATING 1.45KW 120V W/JAM NUTS & SILICONE O-RING
6	<a href="#">WC-1438-101</a>	SENSOR, TEMPERATURE TANK
7	<a href="#">WC-4394</a>	GUARD, SHOCK/HEATING ELEMENT FOR SINGLE HEATING ELEMENT

ITEM #	PART #	DESCRIPTION
8	<a href="#">WC-521</a>	THERMOSTAT, HI-LIMIT SPST 120V 15A AUTO-RE-SET
9	<a href="#">WC-2627</a>	BUSHING, CONICAL .583ID X .945 OD .886LG 12mm GEN USE
10	<a href="#">WC-2628</a>	BUSHING, CONICAL.469 ID X .945 OD X .986 LG 8mm GEN USE
11	<a href="#">WC-29042</a>	HOSE, VENTILATION HEATING TANK CAFÉ

WC-54117 - Recommended Parts to Stock

ITEM #	PART #	DESCRIPTION
3	<a href="#">WC-43062</a>	GASKET, TANK LID
5	<a href="#">WC-917-04</a>	ELEMENT, HEATING 1.45KW 120V W/JAM NUTS & SILICONE O-RING
6	<a href="#">WC-1438-101</a>	SENSOR, TEMPERATURE TANK
7	<a href="#">WC-4394</a>	GUARD, SHOCK/HEATING ELEMENT FOR SINGLE HEATING ELEMENT

ITEM #	PART #	DESCRIPTION
8	<a href="#">WC-521</a>	THERMOSTAT, HI-LIMIT SPST 120V 15A AUTO-RE-SET
9	<a href="#">WC-2627</a>	BUSHING, CONICAL .583ID X .945 OD .886LG 12mm GEN USE
10	<a href="#">WC-2628</a>	BUSHING, CONICAL.469 ID X .945 OD X .986 LG 8mm GEN USE

WC-53043-30 - Tank Assembly

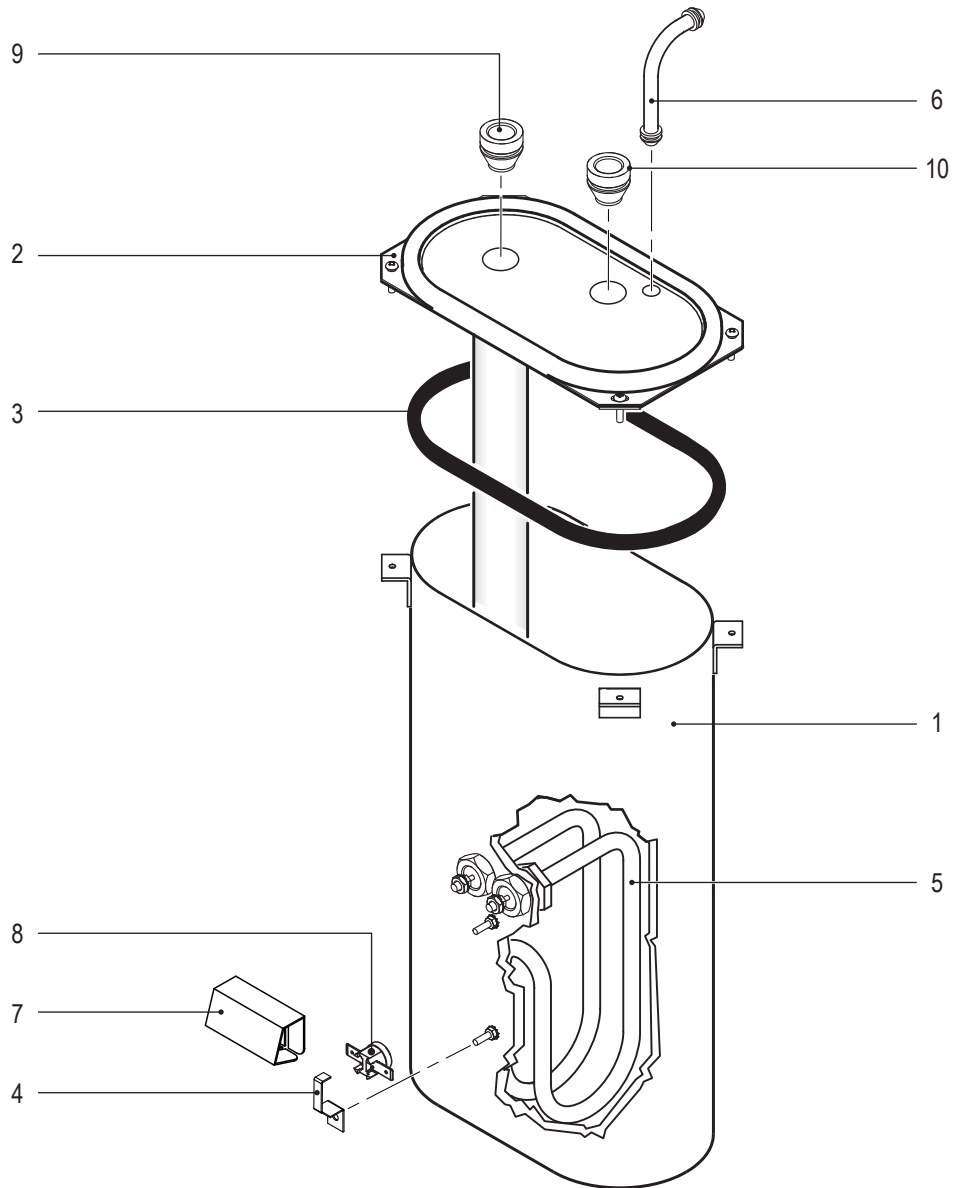

WC-53043-30 - Tank Assembly - Parts List

ITEM #	PART #	DESCRIPTION
1	WC-53043	TANK, HEATING ASSY CAFÉ 1/2/3 2000W 220V
2	WC-54125-101	COVER, W/A HEATING TANK CAFÉ
3	WC-43062*	GASKET, TANK LID
4	WC-5418	CLIP, RESET THERMOSTAT GEN USE
5	WC-906-04	KIT, ELEMENT, HEATING 2KW 220V W/ JAM NUT & SILICONE O-RING
6	WC-29042	HOSE, VENTILATION HEATING TANK CAFÉ

ITEM #	PART #	DESCRIPTION
7	WC-4394*	GUARD, SHOCK/HEATING ELEMENT FOR SINGLE HEATING ELEMENT
8	WC-521*	THERMOSTAT, HI-LIMIT SPST 120V 15A AUTO-RE-SET
9	WC-2627*	BUSHING, CONICAL .583ID X .945 OD .886LG 12mm GEN USE
10	WC-2628*	BUSHING, CONICAL.469 ID X .945 OD X .986 LG 8mm GEN USE

\* Recommended parts to stock.

CAFE Pourover Brewers - 120 Volt

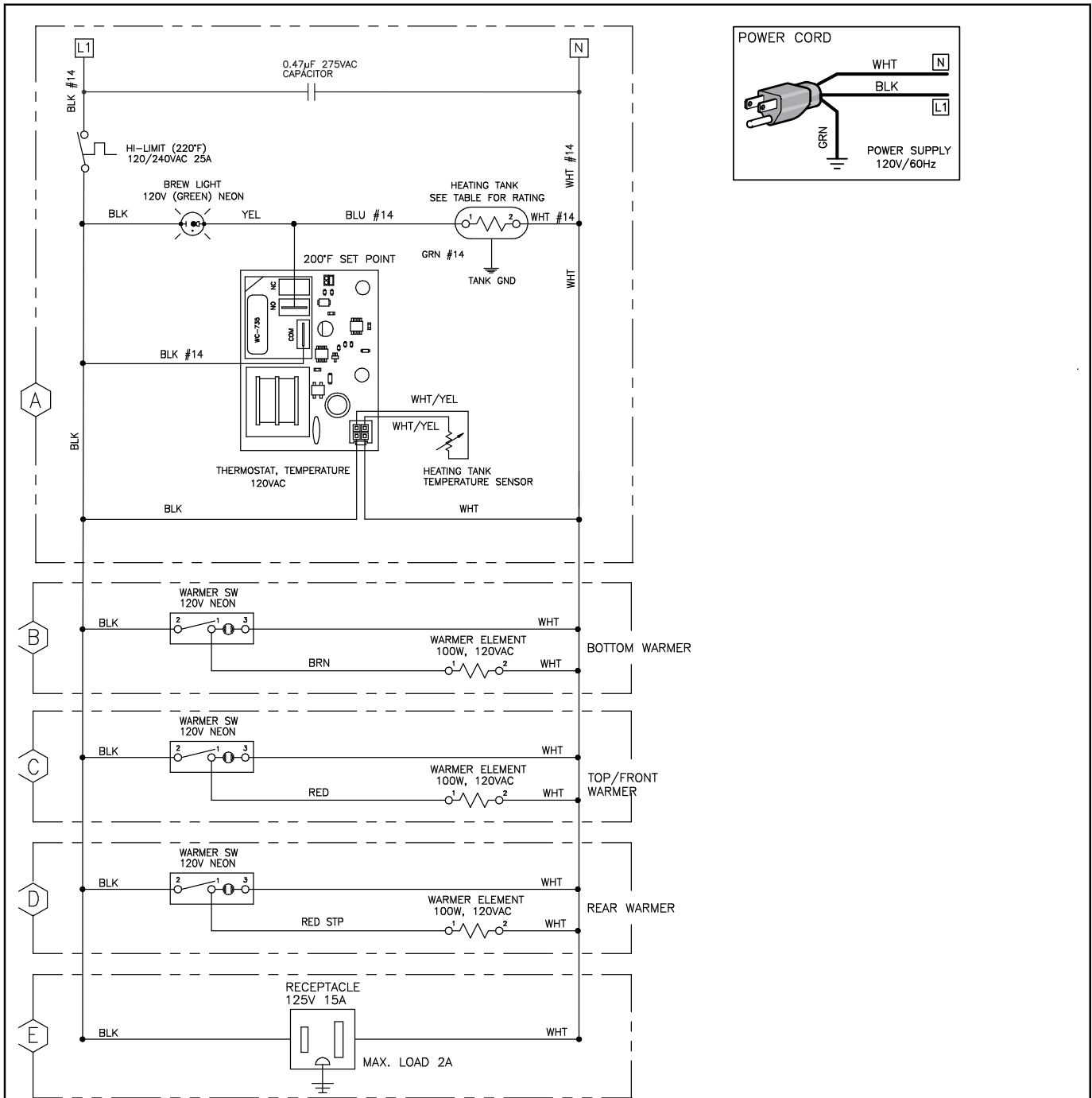

MODEL AND ELECTRICAL TABLE								
MODEL	HEATING ELEMENT	CIRCUIT	VOLTS	WATTS	AMPS	HERTZ	WIRE	PHASE
CAFE0AP10	WC-917	A	120VAC	1450W	12.1A	50/60HZ	2W + G	1-PHASE
CAFE1DB10	WC-917	A + B	120VAC	1550W	12.9A	50/60HZ	2W + G	1-PHASE
CAFE2DB10	WC-917	A + B + C	120VAC	1650W	13.8A	50/60HZ	2W + G	1-PHASE
CAFE2DBS10	WC-917	A + B + C + E	120VAC	1650W	13.8A	50/60HZ	2W + G	1-PHASE
CAFE3DB10	WC-917	A + B + C + D	120VAC	1750W	14.6A	50/60HZ	2W + G	1-PHASE
CAFE1DB20	WC-933	A + B	120VAC	1250W	10.4A	50/60HZ	2W + G	1-PHASE
CAFE2DB20	WC-933	A + B + C	120VAC	1350W	11.3A	50/60HZ	2W + G	1-PHASE
CAFE3DB20	WC-933	A + B + C + D	120VAC	1450W	12.1A	50/60HZ	2W + G	1-PHASE

1. ALL WIRES SHALL BE 18AWG PVC-105C.  
 NOTES: UNLESS OTHERWISE SPECIFIED.

VOLTAGE: SEE TABLE	TITLE:
WATTAGE: SEE TABLE	LADDER DIAGRAM
AMPERAGE: SEE TABLE	PART NUMBER:
HERTZ: SEE TABLE	LD-CAFE-10
WIRE: SEE TABLE	REVISION:
PHASE: SEE TABLE	T



**WARNING:**

**Electric Shock Hazard** - the following procedures are to be performed only by a qualified service technician. Disconnect power when replacing components. Neither Wilbur Curtis Co., Inc. nor the seller can be held responsible for the interpretation of this information, or any liability in connection with its use.

**Scald and Burn Hazard** - keep body parts clear of hot surfaces during troubleshooting.

**Troubleshooting Guidelines**

- A brewer that is not level may not function properly. Make sure the brewer is properly leveled before proceeding.
- This troubleshooting guide identifies some, but not all, of the possible causes for common problems that can occur.
- Use this troubleshooting guide along with the appropriate *ELECTRICAL SCHEMATIC*.

**No Power, Nothing Works**

- 1 Make sure the circuit breaker to the circuit supplying power to the brewer is not tripped and is turned on.
- 2 Make sure the power plug is connected to the power receptacle.
- 3 On units equipped with a main power toggle switch on the back, make sure that it is in the ON position.
- 4 Verify that all wires from the power cord are properly connected inside the unit. Check to make sure the wires are not burned/overheated. Loose connections can create heat. Check chassis ground.
- 5 Check for power into and out of the thermostat reset (HI-LIMIT) switch. If there is power into the HI-LIMIT switch, but not out, check to make sure that the water tank is not empty. If the tank is empty, refill the water tank according to the *INSTALLATION INSTRUCTIONS* and push the HI-LIMIT reset button.
- 6 If there is water in the tank, but no power out, push in on the HI-LIMIT reset button when the water is cool, to see if it restores power. If power is restored, check to make sure that the switch is not opening up at the wrong temperature (the switch should not open up at normal water temperatures).
- 7 If there is still no power through the switch after pushing the button, replace the HI-LIMIT switch.

**Water Does Not Heat At All**

If the water heats, but is not hot enough, see *Water Not Hot Enough*.

**READY TO BREW indicator lights, but the water does not heat, units with electronic thermostat**

- 1 Check all of the power and neutral connections to the thermostat board. Check the wire from the thermostat board to the heating element. Note that there are two hot connections to the board.
- 2 Check the resistance across the leads of the temperature sensor. If the resistance is less than 10 k and the water is not hot, replace the temperature sensor. If the sensor resistance is above 10 k when the water is cool, replace the thermostat board.

**READY TO BREW indicator lights, but the water does not heat, units with mechanical (capillary) thermostat**

- 1 Check the electrical connections to and from the thermostat module. Check wire from the thermostat board to the heating element.
- 2 Check the thermostat setting. Make sure that it is not turned off.
- 3 If the wiring is OK and the thermostat is properly set, replace the thermostat.

## Water Does Not Heat At All (cont.)

### READY TO BREW indicator not lit, all units

- 1 Make sure power is being supplied to the unit. See *No Power, Nothing Works* section.
- 2 Check the water temperature. If the water is hot, check the wiring to the READY TO BREW light and the light itself.
- 3 Check for power across the terminals of the heating element. If power is being supplied, remove the wires and check for an open heating element.
- 4 If there is no power to the heating element, trace the circuit back (using the *ELECTRICAL SCHEMATIC*) to find out where power is lost.

### Water Not Hot Enough

- 1 If the water heats, but is not hot enough, first check for the correct thermostat temperature setting. See the *PROGRAMMING GUIDE* section.

If the temperature setting is OK, measure the water temperature when the READY TO BREW light is on with a thermometer.

Units with an Electronic Thermostat: If the temperature is cooler than the thermostat setting replace the temperature sensor.

Units with an Mechanical Thermostat: If the temperature is cooler than the thermostat setting replace the thermostat.

### Water Too Hot (Boiling or Excessive Steaming)

---



**IMPORTANT:** Before proceeding, make sure that the thermostat is adjusted to compensate for higher elevations. See the *PROGRAMMING GUIDE* section.

---

Units with an Electronic Thermostat:

- 1 First check to make sure that the temperature sensor is attached tightly to the tank and that heat sink compound was used. A properly mounted sensor should have a resistance of around 7 k when the water is hot. If not, replace the sensor.
- 2 Check to see if the thermostat constantly supplies power output to the heating element, regardless of the resistance of the temperature sensor. If so, the thermostat board is probably bad.

Units with an Mechanical Thermostat:

- 1 Check to see if the thermostat constantly supplies power output to the heating element, regardless of the thermostat setting. If so, the thermostat is bad.

### Water Heats More Slowly Than Usual

See *Water Not Hot Enough*.

### Slow Flow From the Spray Head

- 1 Delime the brewer according to the *CLEANING* section.
- 2 Check for a clogged spray head.

Wilbur Curtis Co., Inc. certifies that its products are free from defects in material and workmanship under normal use. The following limited warranties and conditions apply:

- 3 years, parts and labor, from original date of purchase on digital control boards
- 2 years, parts, from original date of purchase on all other electrical components, fittings and tubing
- 1 year, labor, from original date of purchase on all other electrical components, fittings and tubing

Additionally, Wilbur Curtis Co., Inc. warrants its grinding burrs for four (4) years from the date of purchase. Stainless steel components are warranted for two (2) years from the date of purchase against leaking or pitting. Replacement parts are warranted for ninety (90) days from the date of purchase or for the remainder of the limited warranty period of the equipment in which the component is installed.

All in-warranty service calls must have prior authorization. For authorization, call the Technical Support Department at 800-995-0417. Additional conditions may apply. Go to [www.wilburcurtis.com](http://www.wilburcurtis.com) to view the full product warranty information.

## CONDITIONS & EXCEPTIONS

The warranty covers original equipment at time of purchase only. Wilbur Curtis Co., Inc., assumes no responsibility for substitute replacement parts installed on Curtis equipment that have not been purchased from Wilbur Curtis Co., Inc. Wilbur Curtis Co., Inc. will not accept any responsibility if the following conditions are not met. The warranty does not cover:

- **Adjustments and cleaning:** *The resetting of safety thermostats and circuit breakers, programming and temperature adjustments are the responsibility of the equipment owner. The owner is responsible for proper cleaning and regular maintenance of this equipment.*
- **Replacement of items subject to normal use and wear:** *This shall include, but is not limited to, spray heads, faucets, light bulbs, shear disks, "O" rings, gaskets, silicone tubing, silicone elbows, canister assemblies, whipper chambers and plates, mixing bowls, agitation assemblies and whipper propellers.*

The warranty is void under the following circumstances:

- **Improper operation of equipment:** *The equipment must be used for its designed and intended purpose and function.*
- **Improper installation of equipment:** *This equipment must be installed by a professional technician and must comply with all local electrical, mechanical and plumbing codes.*
- **Improper voltage:** *Equipment must be installed at the voltage stated on the serial plate supplied with this equipment.*
- **Improper water supply:** *This includes, but is not limited to, excessive or low water pressure and inadequate or fluctuating water flow rate.*
- **Damaged in transit:** *Equipment damaged in transit is the responsibility of the freight company and a claim should be made with the carrier.*
- **Abuse or neglect (including failure to periodically clean or remove lime accumulations):** *The manufacturer is not responsible for variation in equipment operation due to excessive lime or local water conditions. The equipment must be maintained according to the manufacturer's recommendations.*
- **Unauthorized repair or modification:** *This equipment must be serviced only by qualified service technicians, using factory specified parts to factory specifications.*
- **Modified/Missing Serial Tag:** *The serial number label (tag) must not be defaced or removed.*

**Repairs and/or Replacements** are subject to Curtis' decision that the workmanship or parts were faulty and the defects showed up under normal use. All labor shall be performed during regular working hours. Overtime charges are the responsibility of the owner. Charges incurred by delays, waiting time, or operating restrictions that hinder the service technician's ability to perform service is the responsibility of the owner of the equipment. This includes institutional and correctional facilities. Wilbur Curtis Co., Inc. will allow up to 100 miles, round trip, per in-warranty service call.

**Return Merchandise Authorization (RMA):** All claims under this warranty must be submitted to the Wilbur Curtis Technical Support Department prior to performing any repair work or return of this equipment to the factory. **All returned equipment must be properly re-packaged in the original carton and received by Curtis within 45 days following the issuance of a RMA.** No units will be accepted if they are damaged in transit due to improper packaging. **NO UNITS OR PARTS WILL BE ACCEPTED WITHOUT A RETURN MERCHANDISE AUTHORIZATION (RMA). THE RMA NUMBER MUST BE MARKED ON THE CARTON OR SHIPPING LABEL. All warranty claims must be submitted within 60 days of service. Invoices will not be processed or accepted without a RMA number. Any defective parts must be returned in order for warranty invoices to be processed and approved.** All in-warranty service calls must be performed by an authorized service agent. Call the Wilbur Curtis Technical Support Department to find an agent near you.