

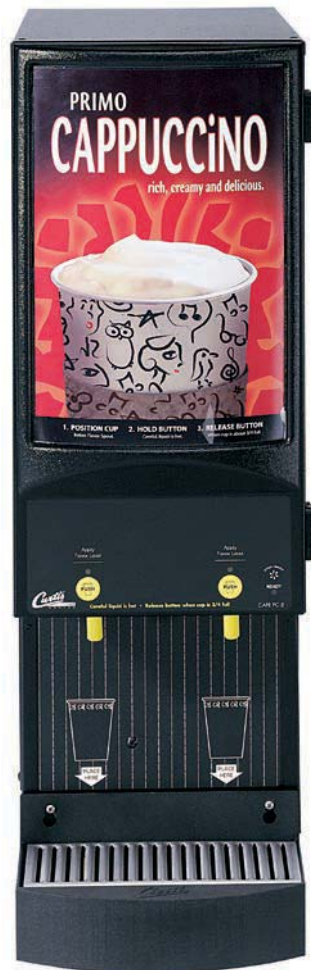

Cafe Primo Cappuccino™ 2 Station Dispensing System



Style Varies - Model CAFEP2CS10000 Shown

READ AND SAVE THESE INSTRUCTIONS

NOTICE TO INSTALLER: Please leave this booklet with the machine.

Key Features/Specifications/System Requirements..... FS45

Important Safeguards..... IS2

Installation Instructions (General).....II2

Installation Instructions (Leveling, Water Supply, Electrical).....II23

Operating InstructionsOI34

Cleaning Instructions (General)..... CI19

Cleaning Instructions (Whipper Plate Assembly) CI20

Programming Guide PG14

Rough-In Drawing..... RD51

Illustrated Parts/Recommended Parts (Main Chassis)..... IP87

Illustrated Parts/Recommended Parts (Tank Assembly, Domestic)..... IP85

Illustrated Parts/Recommended Parts (Tank Assembly, Export) IP86

Electrical SchematicsES89

Troubleshooting Guide (General).....TG25

Troubleshooting Guide (Dump Valve Calibration).....TG24

Error CodesEC8

Product Warranty.....PW1

Contact Information

Wilbur Curtis Co., Inc.

6913 Acco Street | Montebello, CA 90640 US
 Phone: 323-837-2300 | Toll Free: 800-421-6150
 Email: csrcassistance@wilburcurtis.com | Web: www.wilburcurtis.com

For the latest specifications and information go to www.wilburcurtis.com
 Toll Free: 800-995-0417 | Monday - Friday 5:30 A.M. - 4:00 P.M. PT
 Email: techsupport@wilburcurtis.com

Due to continued product improvement, the products illustrated/photographed in this guide may vary slightly from the actual product.

Key Features

- Fits Anywhere – The Café PC's compact size lets you place it virtually anywhere. A close water connection and standard 120VAC power allows use of any available outlet.
- Low Maintenance Costs – The key components that ensure reliable operation in the Café PC are same heavy-duty components used in our top-of-the-line PCGT models. Many components are shared across all four models within the Cafe Series.
- Consistent Drink Quality – Café models utilize Curtis' proven advanced digital control module that allows precision blending for consistently great beverages. Powder-to-water ratio is set right from the front panel, so there's never a need to manually adjust internal valves. Plus, Café series machines can be set for continuous or portion control dispensing.

Specifications (Selected Models)

Electrical Supply Requirements

MODEL #	DESCRIPTION	PHASE	VOLTS	AMPS	HEATING CONFIG	WIRE	WATTS	HERTZ	GAL/HR
CAFEP2CL10000	2 Station with light box	1 PH	120 V	15.0 A	1 x 1600 W	2W + G	1800 W	50/60 Hz	5.3
CAFEP2CS10000	2 Station	1 PH	120 V	15.0 A	1 x 1600 W	2W + G	1800 W	50/60 Hz	5.3
EXPORT									
CAFEP2CL3x	2 Station, export with light box	1 PH	220-240V	9.9-10.8 A	1 x 2000 W	2W + G (1/N/PE)	2175-2592 W	50/60 Hz	5.3
CAFEP2CS3x	2 Station, export	1 PH	220-240V	9.9-10.8 A	1 x 2000 W	2W + G (1/N/PE)	2175-2592 W	50/60 Hz	5.3

Dimensions

Water Supply Requirements

MODEL #	HEIGHT	WIDTH	DEPTH	SHIP WEIGHT	SHIP CUBE	WATER CONNECTOR	WATER PRESSURE	MIN. FLOW RATE
CAFEP2CL10000	31.13"	10.00"	23.43"	64.00 lbs	9.44 cu ft	1/4" flare	20 - 90 psi	1.0 gpm
CAFEP2CS10000	31.13"	10.00"	21.75"	63.00 lbs	9.44 cu ft	1/4" flare	20 - 90 psi	1.0 gpm
EXPORT								
CAFEP2CL3x	31.13"	10.00"	23.43"	64.00 lbs	9.44 cu ft	1/4" flare	20 - 90 psi	1.0 gpm
CAFEP2CS3x	31.13"	10.00"	21.75"	63.00 lbs	9.44 cu ft	1/4" flare	20 - 90 psi	1.0 gpm

Following are the factory default settings for the Cafe Primo Cappuccino dispenser:

- Water Temperature = 190°F (standard units)
- Dispensing = Manual

Symbols



This is the safety alert symbol. It is used to alert you to potential physical injury hazards. Obey all safety messages that follow this symbol to avoid possible injury or death.



DANGER - Indicates a hazardous situation which, if not avoided, will result in death or serious injury.



WARNING - Indicates a hazardous situation which, if not avoided, could result in death or serious injury.



CAUTION - Indicates a hazardous situation which, if not avoided, could result in minor or moderate injury.



NOTICE - Indicates a situation which, if not avoided, could result in property damage.



IMPORTANT - Provides information and tips for proper operation.



SANITATION REQUIREMENTS



WARNING - This product can expose you to chemicals including Acrylamide and Bisphenol A (BPA), which are known to the State of California to cause cancer and birth defects or other reproductive harm. For more information visit www.P65Warnings.ca.gov.

Important Safeguards/Conventions



WARNING:

- Make sure that this appliance is installed and grounded according to the INSTALLATION INSTRUCTIONS by qualified personnel before attempting to use it. Failure to follow the INSTALLATION INSTRUCTIONS could result in personal injury or void the warranty.
- This appliance is designed for commercial use. Any service other than cleaning and preventive maintenance should be performed by an authorized Wilbur Curtis service technician.
- To reduce the risk of fire or electric shock, DO NOT open the service panels. There are no user serviceable parts inside.
- Keep hands, arms and other items away from hot surfaces of the unit during operation.
- Clean the appliance and any dispensers completely before using them for the first time according to the CLEANING INSTRUCTIONS. Clean them regularly as instructed in the CLEANING INSTRUCTIONS.
- Use this appliance only for its intended use, brewing/dispensing hot and/or cold beverages/water.
- This appliance is not intended for use by persons (including children) with reduced physical, sensory or mental capabilities or lack of experience and knowledge, unless they have been given supervision or instruction concerning use of the appliance by a person responsible for their safety. Children should be supervised to ensure that they do not play with the appliance.
- Avoid spillage onto the power (mains) connector.

CE Requirements

- This appliance must be installed in locations where it can be overseen by trained personnel.
- For proper operation, this appliance must be installed where the temperature is between 5°C to 35°C.
- This appliance is not suitable for outdoor use.
- This appliance shall not be tilted more than 10° for safe operation.
- An electrician must provide electrical service as specified in conformance with all local and national codes. For safe use, an all-pole disconnection must be incorporated into the fixed wiring in accordance with the wiring rules outlined in clause 7.12.2 of IEC 60335 for meeting the minimum electrical safety of this standard.
- This appliance must not be cleaned by water jet.
- This appliance can be used by persons aged from 18 years and above if they have been given supervision or instruction concerning use of the appliance in a safe way and if they understand the hazards involved.
- Keep the appliance and its cord out of reach of children aged less than 18 years.
- Appliances can be used by persons 18 years and above with reduced physical, sensory or mental capabilities or lack of experience and knowledge if they have been given supervision or instruction concerning use of the appliance in a safe way and understand the hazards involved.
- Children under the age of 18 years should be supervised to ensure they do not play with the appliance.
- If the power cord is ever damaged, it must be replaced by the manufacturer or authorized service personnel with a special cord available from the manufacturer or its authorized service personnel in order to avoid a hazard.
- Machine must not be immersed for cleaning.
- Cleaning and user maintenance shall not be made by children unless they are older than 18 years and supervised.
- This appliance is intended to be used in household and similar applications such as:
 - staff kitchen areas in shops, offices and other working environments;
 - by clients in hotels, motels and other residential type environments;
 - bed and breakfast type environments.
- This appliance not intended to be used in applications such as:
 - farm houses
- Access to the service areas permitted by Authorized Service personnel only.
- The A-Weighted sound pressure level is below 70 dBA.

Disposal of Equipment

- This product contains plastic, metal and electronic components and is considered e-waste. At the end of its life, this product must not be disposed of in normal household waste but can be instead delivered to a collection point for recycling electric and electronic appliances, consult with the local municipality for proper disposal guidelines.



WARNING: Installation is to be performed only by a qualified installer.



WARNING: Improper electrical connection may result in an electric shock hazard or damage the unit. This appliance must be properly grounded.



NOTICE: DO NOT connect this appliance to a hot water supply. The water inlet valve is not rated for hot water. Do not exceed the maximum water pressure stated in the **SPECIFICATIONS** section.



IMPORTANT: Observe all governing codes and ordinances.

Installation Instructions

Installation Requirements

- A secure surface capable of supporting the weight of the appliance.
- For units without an attached cord set attached or dual voltage units set up for use with 220 - 240 Volts: Appropriately sized, UL listed, grounding type power cable to meet the electrical specifications for the appliance. If you have questions about the correct cable size and length, consult a qualified installer. If the appliance will be hard wired to a junction box, the power cable must be long enough so that the unit can be moved for cleaning underneath.
- A grounded electrical connection to an electrical circuit that meets the electrical specifications of the appliance (see **SPECIFICATIONS**). The circuit must be protected by the appropriate sized circuit breaker. If you are not certain that the existing circuit meets the requirements for your unit, consult a licensed electrician.
- A water filtration system is required to maintain trouble-free operation. Wilbur Curtis Co., Inc. recommends a Wilbur Curtis approved water filter. See the Curtis Equipment Catalog for a full line of Wilbur Curtis approved water filters.
- Potable water supply line connection from the water filter capable of supplying the minimum flow rate required by the specifications. The water supply line must be able to connect to the flare fitting on the back of the unit. See the **SPECIFICATIONS** section for the correct size. The water line should also be capable of being controlled by a shut off valve. Do not connect the water line to a saddle valve or needle valve.

IEC requires the following water connection:

- 1 A quick disconnect or additional coiled tubing (at least two times the depth of the appliance) is required so that it can be moved for cleaning underneath.
- 2 This equipment is to be installed with adequate back-flow protection to comply with applicable federal, state and local codes.
- 3 Water pipe connections and fixtures directly connected to a potable water supply shall be sized, installed and maintained in accordance with federal, state and local codes.

The International Plumbing Code of the International Code Council and the Food and Drug Administration (FDA) Food Code manual, direct that this equipment must be installed with adequate back-flow prevention in compliance with federal, state and local codes. For units installed outside of the U.S.A., make sure that the installation is in compliance with the applicable plumbing/sanitation code for your area.

Installation

Leveling



WARNING: Use the leveling legs to level the dispenser only. Do not use them to adjust dispenser height. Do not extend them higher than necessary.

- 1 Position the dispenser on the counter top. Level it left to right and front to back by turning the bottom of the legs.

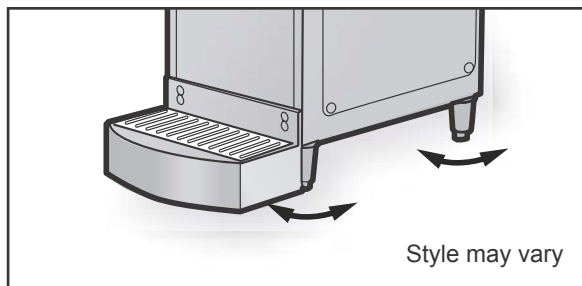

Connect the Water Supply

- 2 Flush the water supply line prior to installation to purge air and debris from the water filter and tubing.
- 3 Connect the water supply line to the flare fitting on the back of the unit. Leave the water supply valve closed until power is connected.

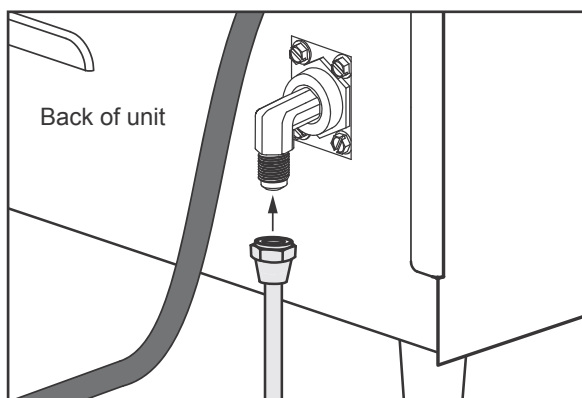

Connect the Power Cable - 120 Volt Units



WARNING: Connect the power cord to the appropriate type and size electrical outlet. If the electrical outlet is not compatible with the power cord, have it upgraded by a licensed electrician. Do not modify the power plug. Do not use an extension cord. Do not use a power cord/plug that is damaged.

- 4 Connect the power cord to the appropriate type of electrical outlet.

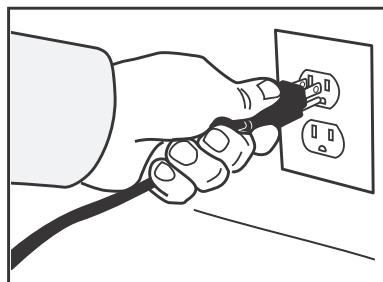

Power Up the Unit

- 5 Turn on the water supply valve.
- 6 Make sure that the circuit breaker supplying power to the dispenser is on.
- 7 Turn the toggle switch on the back of the dispenser to the ON position. The water tank will start to fill.* While the tank is filling, inspect the water supply line for leaks.

*The STOP/WASH light comes on while the tank is filling and the water is heating up.

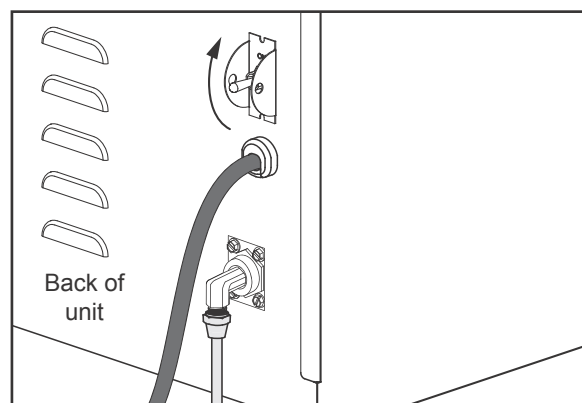

8 When the water level in the tank rises to the correct volume, the heating element will turn on automatically. Depending on the incoming water temperature and the electrical specifications, the water tank typically requires 30 minutes to reach the factory set operating temperature. When the water has heated, the STOP/WASH light will turn off and the ready light(s) will turn on.

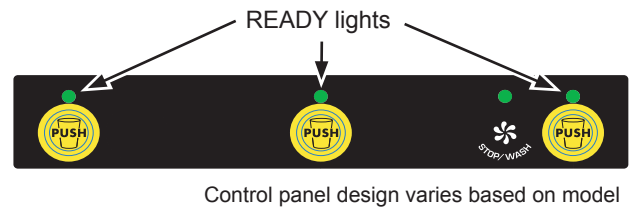

9 Dispense at least 12 ounces from each spout, to purge any remaining air from the tubing. See **OPERATING INSTRUCTIONS**. During initial dispensing, and whenever the filter is replaced, you may hear the sounds of air being purged from the filter, tubing and water tank.

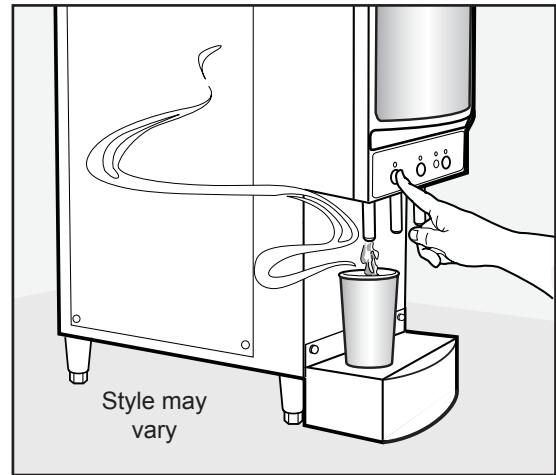

Dispensing

⚠ WARNING - TO AVOID SCALDING, AVOID SPLASHING. Keep body parts clear of the spout during dispensing. Do not remove the cup during dispensing.

The dispenser is factory preset for optimal performance.

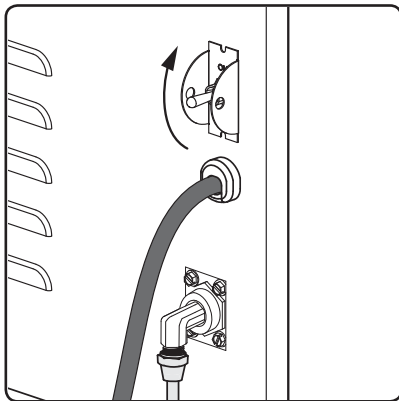

1 The unit should be ON. Confirm this at the rear toggle switch. The ready lights* should be on.

* The light(s) above the dispense (PUSH) button(s).

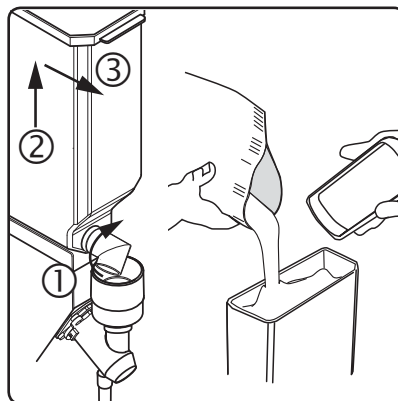

2 Open the front panel. Turn the elbow on each canister to be filled upward, then lift each canister up and out. Fill with powdered cappuccino product.

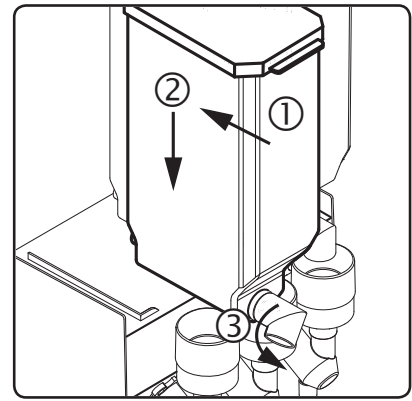

3 Reinstall each canister in the same spot it was removed from. Properly mate the gear socket on the back of each canister with the gear inside the dispenser. Turn the canister elbows downward and close the door.

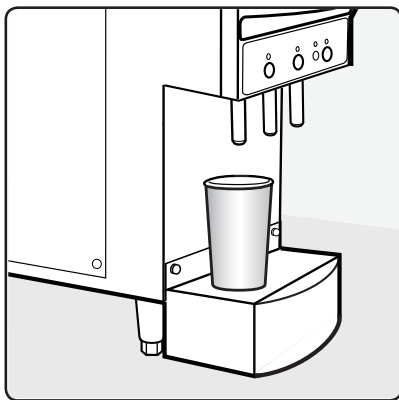

4 Place a cup under the spout for the desired flavor. If the unit is set to dispense iced cappuccino, put ice in the cup first.

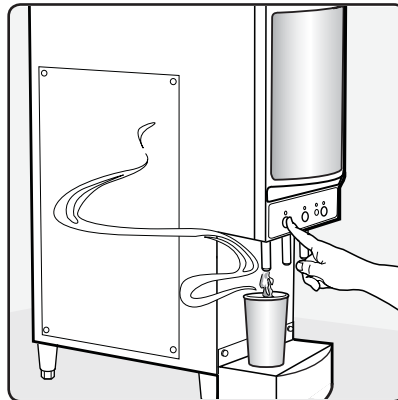

If Set Preset Dispense Mode:**

5 Push and release the dispensing button for the desired flavor and cup size. Remove the cup when product stops flowing.

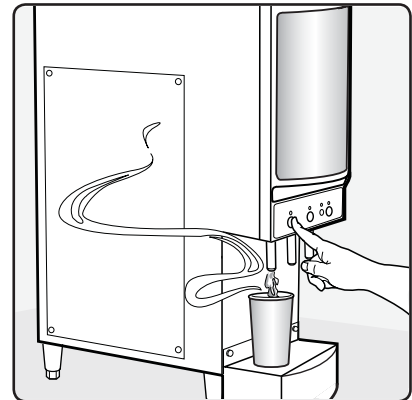

Manual Dispense Mode:

5 Push and hold the dispensing button for the desired flavor. Release the button when the cup is 3/4 full. Remove the cup when product stops flowing.

** See *Programming Guide*.

Spout Cleaning - Every 3 or 4 Hours

- 1 Make sure power is ON.
- 2 Place a container under the dispense spout to catch the rinse water.
- 3 Rinse each flavor by pressing and holding the WASH button, while at the same time pressing one of the PUSH dispensing buttons on the control panel. Continue holding the WASH button until the water running from the spout runs clear.

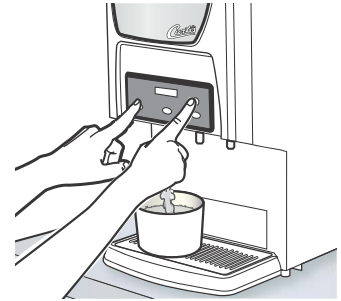

Cleaning the Exterior - Daily



WARNING: HOT SURFACES - To avoid injury, allow the dispenser to cool before cleaning.



WARNING: DO NOT immerse the dispenser in water or any other liquid.



NOTICE - Do not use cleaning liquids, compounds or powders containing chlorine (bleach) or corrosives. These products promote corrosion and will damage the finishes. **USE OF THESE PRODUCTS WILL VOID THE WARRANTY.**

The dispenser should be OFF. Turn the brewer off by flipping the rear toggle switch to the OFF position.

- 1 Wipe the exterior dispenser surfaces with a damp cloth to remove spills and debris.
- 2 Lift the drip tray up to remove. Remove the louvered grill from the drip tray, then wash out the tray with the detergent solution. Wash the louvered grill, then rinse both pieces with water and dry.
- 3 Wipe and clean the dispensing area with the detergent solution, then reinstall the drip tray.

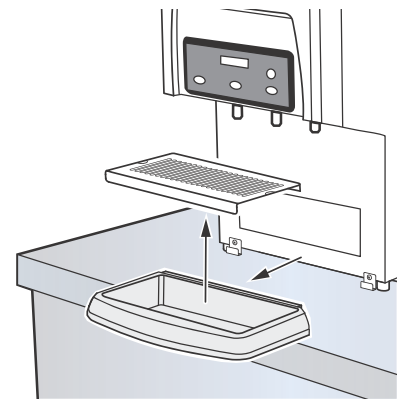

Cleaning The Whipper Plate Assembly CAFEPCC and PCGT Series - Weekly or As Needed

The following cleaning process requires a mild solution of dish-washing detergent and warm water, One-Pro Beverage Equipment Cleaner (Curtis PN WC-79001) and food grade lubricant (Curtis PN WC-4916). Mix the One-Pro cleaner at a ratio of 1 oz. (28 g.) per 5 gal. (19 L) of hot water (122°F/50°C min.).

The dispenser should be OFF. Turn the dispenser off by turning the rear toggle switch to the OFF position.

- 1 Remove the dispensing spout from the whipper chamber. Clean the inside using a narrow brush.
- 2 Pull the upper mixing cup forward and twist it up and to the left to separate it from the lower mixing cup.
- 3 To remove the lower mixing cup, pull it up and forward to free it from the hot water inlet.
- 4 Take hold of the whipper chamber. Turn it clock-wise to free it from the mounting plate.
- 5 Pull the whipper propeller off of the motor shaft.
- 6 Wash, rinse, sanitize and air dry the whipper assembly parts using the 3-sink method. Wash in the mild detergent solution, rinse in warm clean water. Place the faucet parts in the One-Pro solution and allow them to soak for 15 minutes. Then rinse thoroughly and air dry.
- 7 Clean the motor shaft with a cloth and mild detergent before removing the mounting plate.
- 8 Twist the mounting plate clockwise and pull it off of the motor shaft.
IMPORTANT - Do not remove the mounting pillars to remove the mounting plate.
- 9 Clean the area behind the mounting plate and the water inlet fitting.
- 10 Lubricate the center seal of the mounting plate with food grade lubricant before reinstalling.

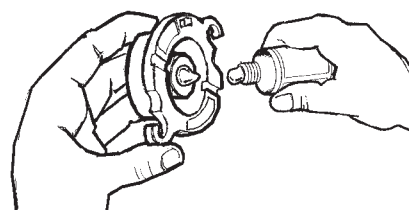
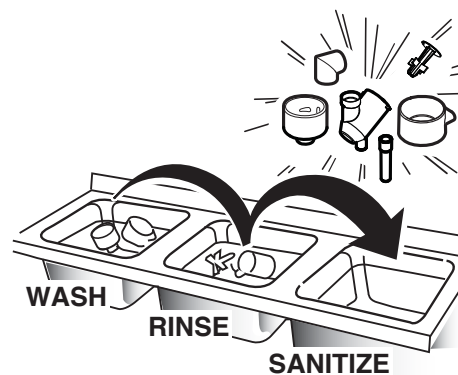
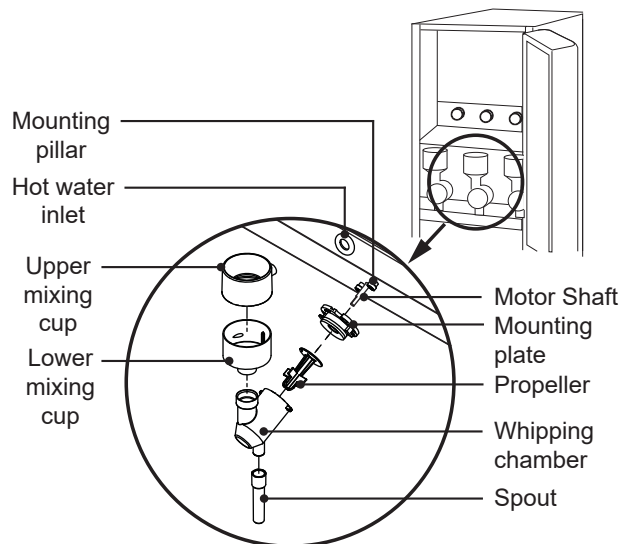

- 11 Reassemble the cleaned whipper assembly parts into the unit in reverse order.



CAUTION: When replacing the propeller, line up the “D” shaped mark on the propeller with the “D” shape on the motor shaft. Failure to line up the propeller properly will cause it to fuse with the shaft. This condition is not covered under the warranty.

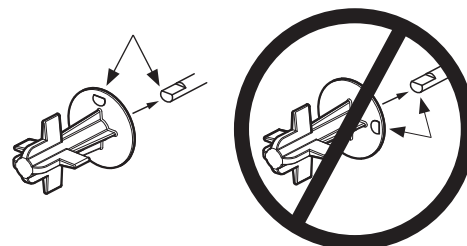

Programming Options

Your Curtis CAFEPc dispenser is factory preset for optimal performance. Generally, there will not be a need to change the programming. If necessary, the following operating parameters can be changed:

- Water temperature
- Manual Dispense Mode/Preset Dispense Mode
- Product % Ratio

Changing the Water Temperature (Factory Default: 190°F-standard units, 100°F-iced cappuccino units)

The following steps can also be used to read the existing temperature setting. The water temperature range is 80° to 206°F.

- 1 The rear toggle switch must be in the ON position and the ready light(s) must be on.
- 2 Press and hold the STOP/WASH button (for about 10 seconds) until all the lights start blinking, then release.
- 3 Press the STOP/WASH button a second time (for about a seconds. The STOP/WASH light will begin to flash a repeated pattern.

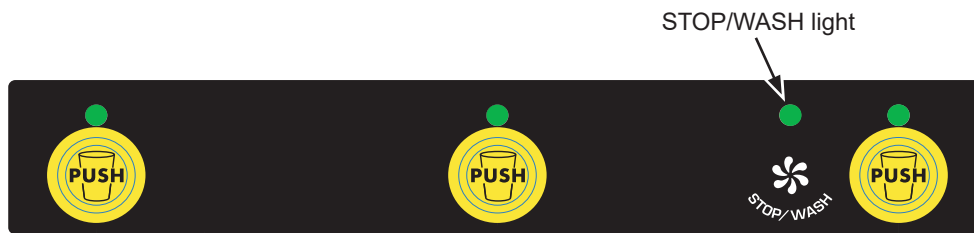

Control panel design varies based on model

- 4 Read the existing temperature setting according to TABLE 1. After a periodic pause, the number of (quick) flashes represents the temperature setting, starting at 80°F. 24 flashes represents the maximum temperature of 206°F.

# of Flashes	Temperature	# of Flashes	Temperature
1	80°F/27°C	13	170°F/77°C
2	85°F/29°C	14	175°F/79°C
3	90°F/32°C	15	185°F/85°C
4	95°F/35°C	16	190°F/88°C
5	100°F/38°C	17	192°F/89°C
6	105°F/41°C	18	194°F/90°C
7	110°F/43°C	19	196°F/91°C
8	120°F/49°C	20	198°F/92°C
9	130°F/54°C	21	200°F/93°C
10	140°F/60°C	22	202°F/94°C
11	150°F/66°C	23	204°F/96°C
12	160°F/71°C	24	206°F/97°C

- 5 To exit without changing the temperature, press one of the PUSH buttons. To change the temperature, press and hold the STOP/WASH button, while watching the number of flashes. Release the STOP/WASH button when the desired temperature is indicated according to TABLE 1.
- 6 Press one of the PUSH buttons to set and exit.

Preset Dispense Mode



WARNING: These steps involve working with hot water. Avoid splashing and spilling.

Preset dispense sets the buttons to dispense the amount of product by time rather than holding the button until the desired amount is dispensed (manual dispense mode). The dispense buttons are set to manual dispense mode at the factory. After being changed to preset dispense, the buttons may be reset to manual dispense according to the section below. To set a button to preset dispense mode:

- 1 Make sure the rear toggle switch is in the ON position and the ready light(s) are on.
- 2 Press and hold the STOP/WASH button (for about 10 seconds) until all the lights start blinking, then release.
- 3 Press and hold the PUSH button to preset until the liquid begins to flow, then release. Preset timing starts when liquid begins to flow.
- 4 When the cup is filled to 3/4 volume, press the PUSH button once again to stop dispensing. The preset volume for the button has now been set.
- 5 Repeat the above process for any other button(s) you wish to set to preset dispense.



Control panel design varies based on model

Manual Dispense Mode

Resets a button set to preset dispense mode, back to manual dispense.



WARNING: These steps involve working with hot water. Avoid splashing and spilling.

- 1 Make sure the rear toggle switch is in the ON position and the ready light(s) are on.
- 2 Press and hold the STOP/WASH button (for about 10 seconds) until all the lights start blinking, then release.
- 3 Press and hold the PUSH button to be set back to manual dispense mode. Hot liquid will start to flow. Continue to hold down the PUSH button until liquid stops flowing, then release. The button has now been reset to manual dispense mode.
- 4 Repeat the above process for any other button(s) you wish to reset to manual dispense mode.

continued...

Product % Ratio

- 1 This function sets the ratio of product powder dispensed. The higher the powder ratio, the richer the product dispensed. The range is from 10% to 100% (7 grams per 10%). The powder ratio for each button is set independent of the others.
- 2 Make sure the rear toggle switch is in the ON position and the ready light(s) are on.
- 3 Press and hold the STOP/WASH button (for about 10 seconds) until all the lights start blinking, then release.
- 4 Press and hold the desired PUSH button for approximately one second, then release.
- 5 The current setting will be indicated by the number of times the light flashes, separated by a pause. See TABLE 2.
- 6 To exit without changing the powder ratio, press one of the other PUSH buttons.
- 7 To change the product throw, press and hold the desired PUSH button again. Read the number of flashes on the light and release when the number of flashes corresponds to the desired setting.
- 8 Press any other PUSH button to set and exit.

# of Flashes	Ratio
1	10% (7 gm)
2	20% (14 gm)
3	30% (21 gm)
4	40% (28 gm)
5	50% (35 gm)
6	60% (42 gm)
7	70% (49 gm)
8	80% (56 gm)
9	90% (63 gm)
10	100% (70 gm)

TABLE 2

CAFEP2

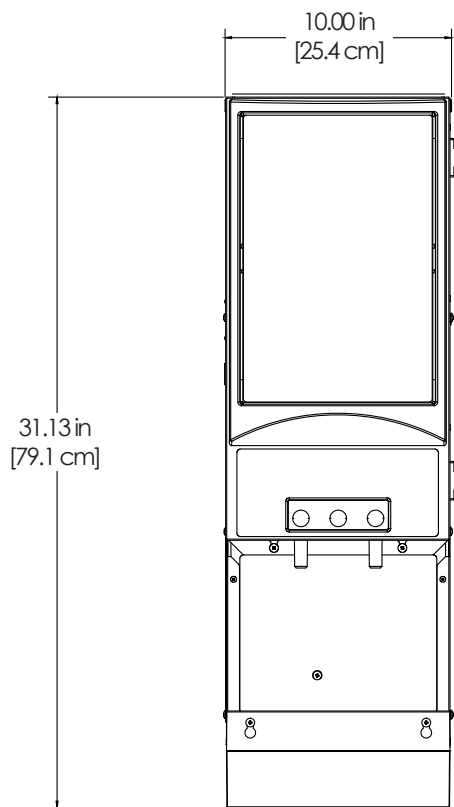
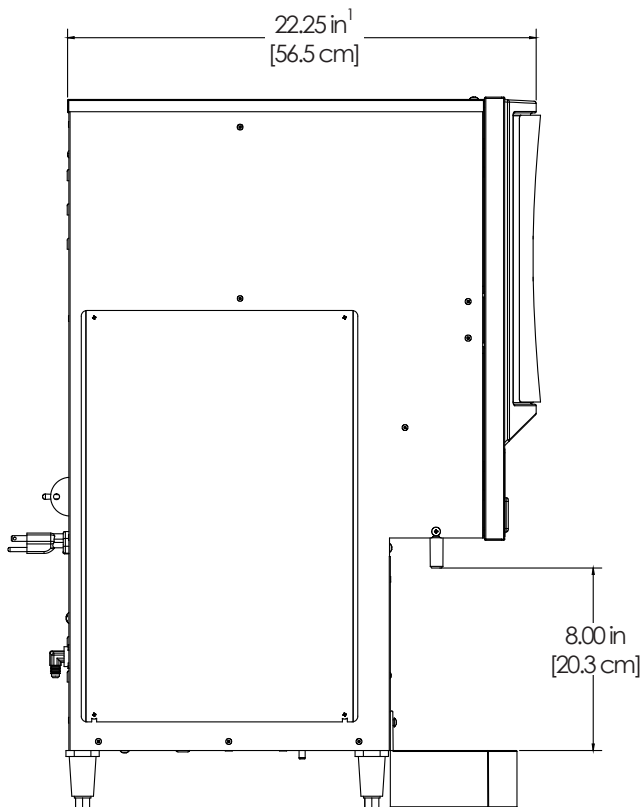
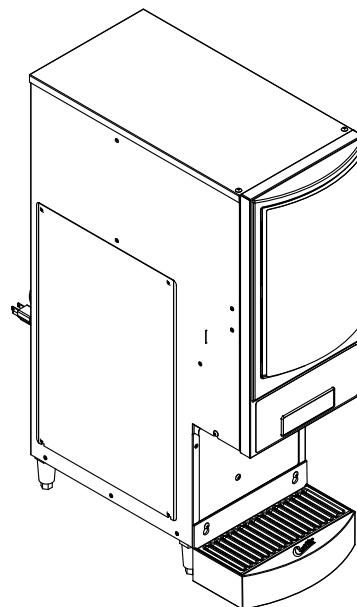
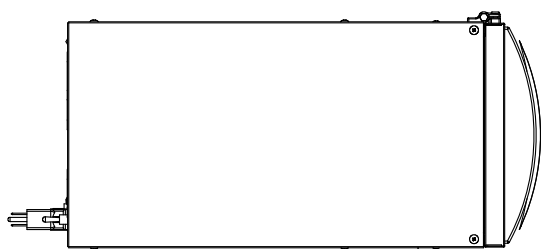

¹EXPORT MODELS:
20.5 in [52.1 cm]

CAFEP2 - Door Assemblies - Exploded View

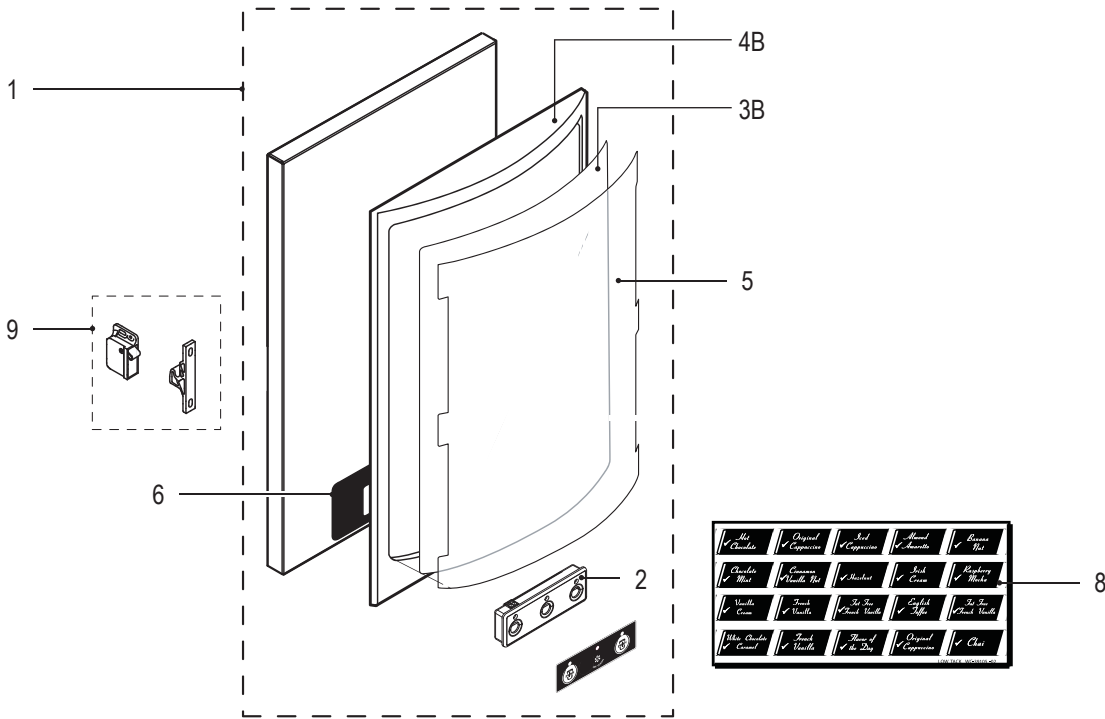

Door Assembly Without Light Box

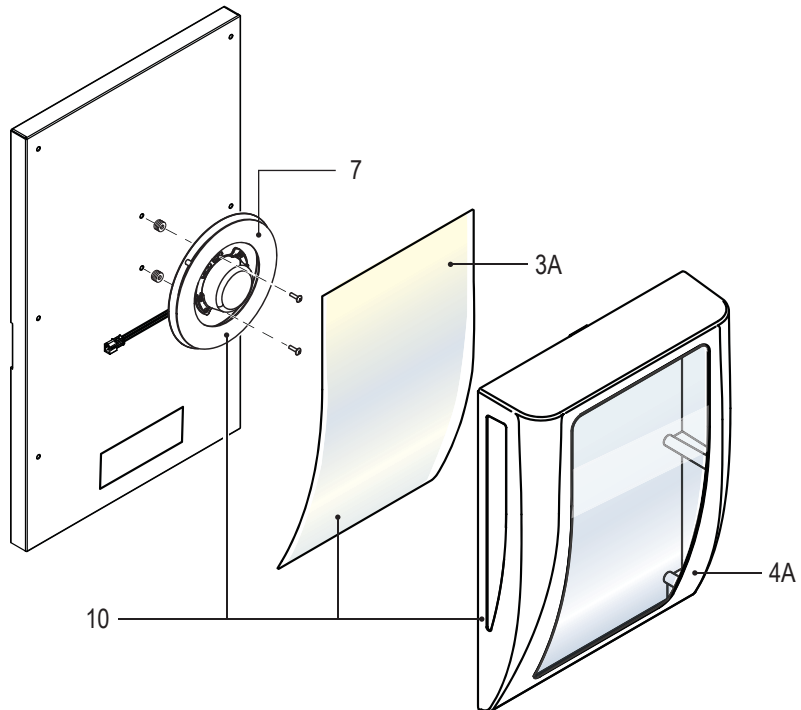

Optional Light Box

CAFEP2 - Door Assemblies - Parts List

ITEM #	PART #	DESCRIPTION
1	WC-58186	DOOR, COMPLETE CAFEP2 (NEW)*
2	WC-732	CONTROL BOARD, SMART CARD SWITCH ASSY COMPLETE CAFEP1/2/4
3A	WC-39481 ^{1,3}	FILM, LIGHT BOX CAFE PC1/PC2 CURTIS
3B	WC-39455 ^{2,4}	FILM, DOOR DISPLAY CAFE PC1&2
4A	CA-1137 ^{1,2}	LIGHT BOX ASSY CAFEP1/CAFEP2
4B	CA-1129 ^{3,4}	COVER, DOOR SKIN CAFEP1/2
5	CA-1132 ^{2,4}	WINDOW, CLEAR FRONT CAFEP1&2

¹CAFEP2CL10000, ²CAFEP2CS10000, ³CAFEP3CL31000, ⁴CAFEP3CS31000

*Does not include item 3, door film/label

Recommended Parts to Stock

ITEM #	PART #	DESCRIPTION
3A	WC-39481	FILM, LIGHT BOX CAFE PC1/PC2 CURTIS
3B	WC-39455	FILM, DOOR DISPLAY CAFE PC1&2

ITEM #	PART #	DESCRIPTION
6	WC-39498	LABEL, ASSY CONTROL PANEL SMART BOARD & OUTER PANEL CAFEP2
7	CA-1176K ^{1,3}	KIT, LAMP ASSY LED 120V 9W CAFEP's
7A	CA-1174K ^{1,3}	KIT, (1)CA-1174 (1) CA-1174-101 CAFEP's
8	WC-39105-02	LABEL, FLAVOR LOW TACK DOOR GEN USE
9	CA-1135	LATCH ASSY, DOOR SIDE MOUNT PCGT'S/CAFEP'S/SD2'S
10	WC-37272 ^{1,3}	KIT, ADD-ON LIGHT BOX ASSY CAFEP1/2

ITEM #	PART #	DESCRIPTION
7	CA-1176K	KIT, LAMP ASSY LED 120V 9W CAFEP's
7A	CA-1174K	KIT, (1)CA-1174 (1) CA-1174-101 CAFEP's

CAFEP2 - Main Chassis - Exploded View

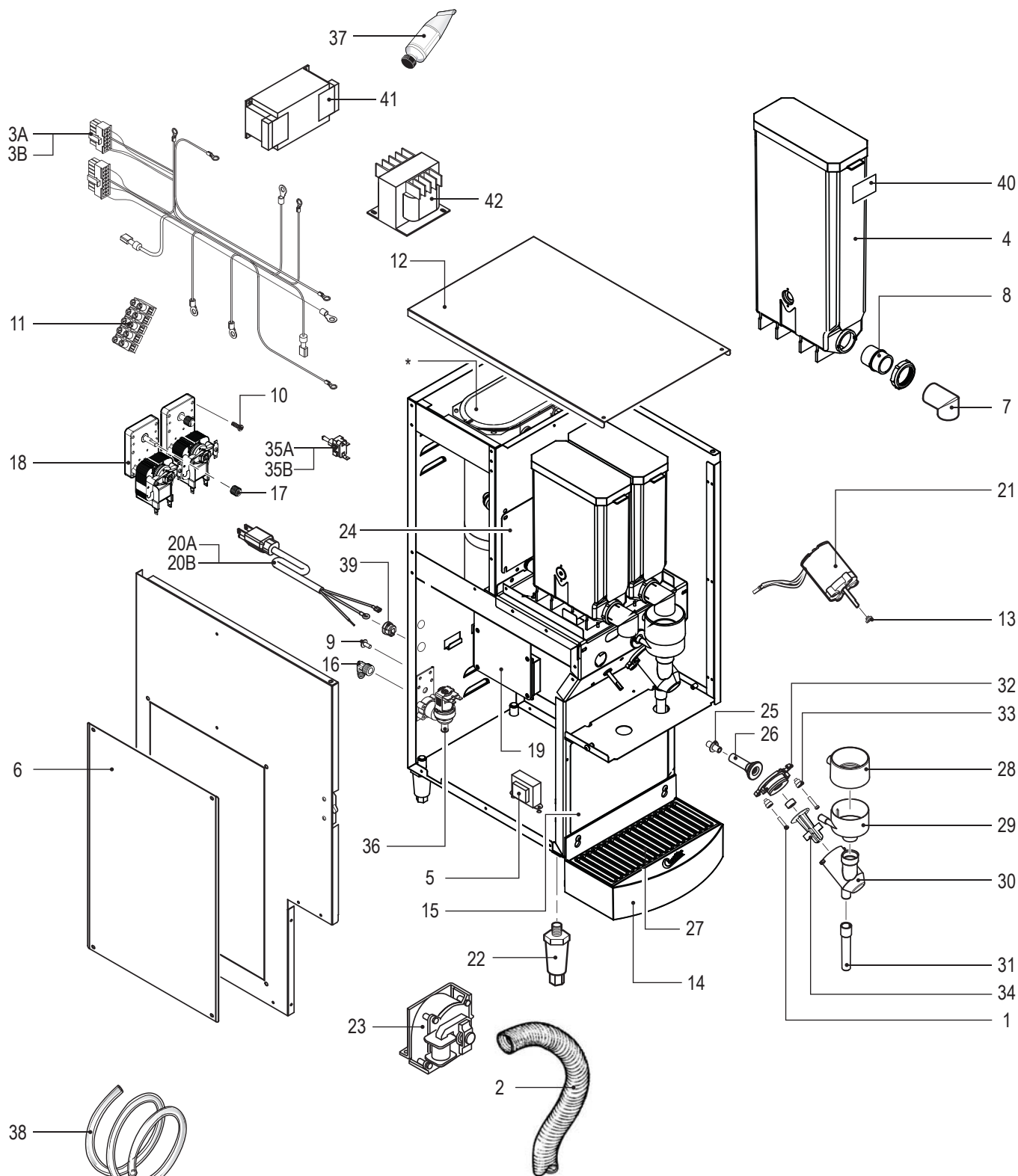

* Water tanks assemblies
 - See section IP85 for domestic models
 - See section IP86 for export models

CAFEP2 - Main Chassis - Parts List

ITEM #	PART #	DESCRIPTION
1	WC-4440	SCREW, 8-32x 3/4" LONG PHILLIP
2	CA-1030-17	HOSE, EXTRACTOR FAN 17" LONG ALL PC'S
3A	WC-13353 ^{1,2}	HARNES ASSY, COMPLETE CAFEP2 FOR SMART CARD VERSION
3B	WC-13414 ^{3,4}	HARNES ASSY, CAFEP2-1/2-31'S (INCLUDES POWER BLOCK AND POWER CABLE)
4	CA-1111-06	CANISTER, ASSY 4LB CAFEP2'S
5	WC-718	TRANSFORMER, 120VAC-12VAC
6	WC-58127	COVER, ACCESS SIDE CAFEP2'S
7	CA-1026-03	ELBOW, PC/CK/HC
8	CA-1065-03-P	BUSHING, DISCHARGE PC/CK/HC
9	WC-4616	SCREW, 1/4-20 x 1/2 PHILLIPS PAN HEAD STAINLESS STEEL
10	WC-4525	SCREW, 8-32x1/4PHILLIPS TRUSS HD SS
11	WC-314 ^{3,4}	POWER BLOCK, 5 STATION
12	WC-58137	COVER, TOP CAFE PC1 & 2
13	WC-43791	RING, MOTOR SHAFT PLASTIC PC'S
14	WC-66035	PAN, DRIP TRAY PLASTIC CAFEP1 CAFEP2
15	WC-38338	LABEL, SPLASH PANEL CAFE PC2 (NEW)
16	WC-2401-P	ELBOW 3/8 NPT X 1/4 FLARE PLTD
17	CA-1036	GEAR, PLASTIC PC'S USE ON CA-1013
18	WC-37174	KIT, GEAR MOTOR AND GEAR PCGT
19	WC-782K	CONTROL POWER MODULE CAFEP2'S 120V USE W/SMART CARD SW CARD
20A	WC-1200 ^{1,2}	CORD, 14/3 SJTO 6' BLK W/PLUG
20B	WC-1231-102 ^{3,4}	CORD, 2.5 mm ² 90°C 36A 450/750 V STRIPPED W/FERRULES ONE END
21	WC-3739	KIT, MOTOR WHIPPER ASSY PC'S MOTOR SCREWS & INSTRUCTIONS
22	WC-3504	LEG, 2-1/2" TO 3" ADJUSTABLE BLACK 3/8-16 THRD

¹CAFEP2CL10000, ²CAFEP2CS10000, ³CAFEP2CL31000, ⁴CAFEP2CS31000

Recommended Parts to Stock

ITEM #	PART #	DESCRIPTION
2	CA-1030-19	HOSE, EXTRACTOR FAN 19" LONG ALL PC'S
13	WC-43791	RING, MOTOR SHAFT PLASTIC PC'S
17	CA-1036	GEAR, PLASTIC PC'S USE ON CA-1013
21	WC-3739	KIT, MOTOR WHIPPER ASSY PC'S MOTOR SCREWS & INSTRUCTIONS
22	WC-3504	LEG, 2-1/2" TO 3" ADJUSTABLE BLACK 3/8-16 THRD
27	WC-66032	SCREEN, DRIP TRAY CAFEP1 & 2
28	CA-1005-03	STEAM TRAP, PC/CK/HC
29	CA-1009-03	BOWL, MIXING PC/CK/HC

ITEM #	PART #	DESCRIPTION
23	WC-37123	KIT, FAN EXTRACT 120V 29 CFM & BRACKET
24	WC-58142	COVER, DUMP VALVE CAFEP1 CAFEP2
25	CA-1095	CONNECTOR, ORIFICE WATER PLASTIC
26	CA-1011-05	BULKHEAD, WATER FITTING PCGT'S
27	WC-66032	SCREEN, DRIP TRAY CAFEP1 & 2
28	CA-1005-03	STEAM TRAP, PC/CK/HC
29	CA-1009-03	BOWL, MIXING PC/CK/HC
30	CA-1006-06	CHAMBER, WHIPPER OFFSET PCGT'S
31	CA-1037-3Y	TUBE, EXTENSION 3.0" LONG YELLOW ALL PCGT'S
32	WC-37118	KIT, WHIPPER PLATE (3/PKG)
33	CA-1024-05	PILLAR, LOCATION BLACK ALL PC'S
34	CA-1008-07K	KIT, PROPELLER WHIPPER PKG/6 OFFSET BLADES PCGT'S/CAFEP2'S
35A	WC-102 ^{1,2,4}	SWITCH, TOGGLE NON-LIT SPST 15A 125/6A 250VAC RESISTIVE
35B	WC-103 ³	SWITCH, TOGGLE NON-LIT DPST 25A 125/250VAC RESISTIVE
36	WC-826L	VALVE, INLET 1 GPM 120V 9W
37	WC-5231	COMPOUND, SILICONE 5 OZ
38	WC-5310	TUBE, 5/16 ID x 1/8W SILICONE GEN USE
39	WC-1408	CORD GRIP, 7/8" O.D.
40	WC-39107-02	LABEL, FLAVOR ADHESIVE CANISTR GEN USE (SET OF 40 DIFFERENT FLAVORS)
41	WC-596K ^{3,4}	KIT, NOISE FILTER EMI 250V/30A
42	WC-710 ^{3,4}	TRANSFORMER,240/480 120V,500VA RU/PCGT/CAFEP2

ITEM #	PART #	DESCRIPTION
30	CA-1006-06	CHAMBER, WHIPPER OFFSET PCGT'S
31	CA-1037-3Y	TUBE, EXTENSION 3.0" LONG YELLOW ALL PCGT'S
32	WC-37118	KIT, WHIPPER PLATE (3/PKG)
34	CA-1008-07K	KIT, PROPELLER WHIPPER PKG/6 OFFSET BLADES PCGT'S/CAFEP2'S
35	WC-102	SWITCH, TOGGLE NON-LIT SPST 15A 125/6A 250VAC RESISTIVE
36	WC-826L	VALVE, INLET 1 GPM 120V 9W
38	WC-5310	TUBE, 5/16 ID x 1/8W SILICONE GEN USE

WC-6291/62019/62020 - Tank Assembly (Domestic)

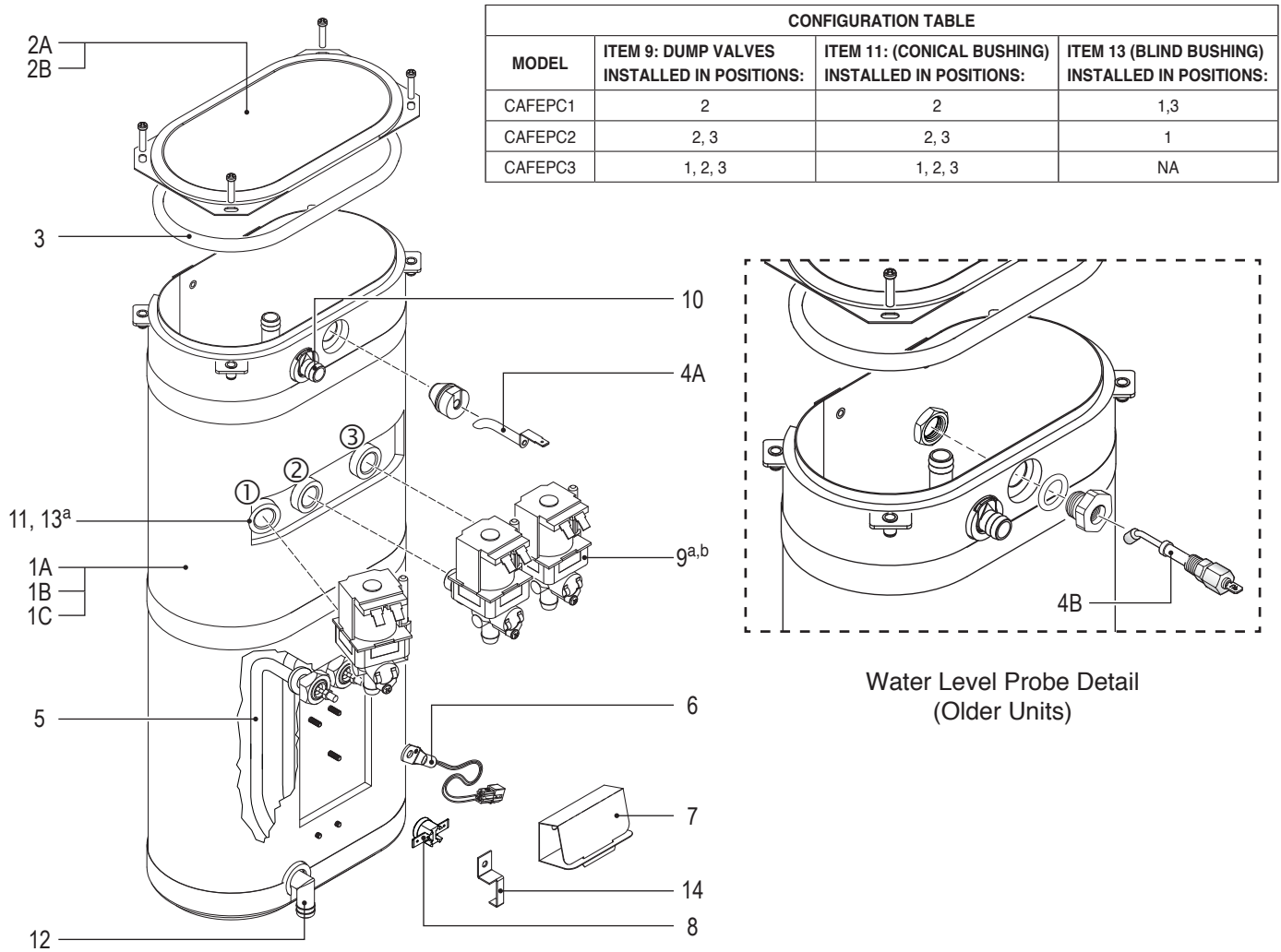

CONFIGURATION TABLE			
MODEL	ITEM 9: DUMP VALVES INSTALLED IN POSITIONS:	ITEM 11: (CONICAL BUSHING) INSTALLED IN POSITIONS:	ITEM 13 (BLIND BUSHING) INSTALLED IN POSITIONS:
CAFEP1	2	2	1,3
CAFEP2	2, 3	2, 3	1
CAFEP3	1, 2, 3	1, 2, 3	NA

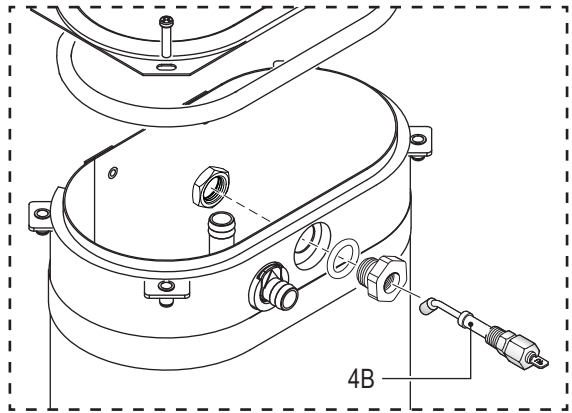

Water Level Probe Detail (Older Units)

^a See CONFIGURATION TABLE.
^b Valve must be calibrated when replaced. See instructions with kit.

WC-6291/62019/62020 - Tank Assembly - Parts List

ITEM #	PART #	DESCRIPTION	ITEM #	PART #	DESCRIPTION
1A	WC-62019	TANK, COMPLETE CAFEP1 1600W 120V	8	WC-521*	THERMOSTAT, HI-LIMIT SPST 120V 15A AUTO-RESET
1B	WC-62020	TANK, COMPLETE CAFEP2 1600W 120V	9	WC-880E*	VALVE, DUMP 120V 12W PC'S
1C	WC-6291	TANK, COMPLETE CAFEP3 1600W 120V	10	WC-37266*	KIT, FITTING TANK OVERFLOW
2A	WC-5853-102	COVER, TOP HEATING TANK GEN USE	11	WC-2627*	BUSHING, CONICAL .583ID X .945 OD .886LG 12mm GEN USE
2B	WC-5851	COVER, TANK W/NOTCHES (UNITS BEFORE 3/08)	12	WC-37365*	KIT, FITTING TANK INLET
3	WC-43062*	GASKET, TANK LID	13	WC-2630*	BUSHING, CONICAL BLIND GEN USE
4A ¹	WC-5528K*	KIT, WATER LEVEL PROBE, SILICONE	14	WC-5418	CLIP, RESET THERMOSTAT GEN USE
4B ²	WC-5502-01*	KIT, PROBE, ASSY WATER LEVEL W/HEX FITTING, O-RING & NUT			
5	WC-904-04*	KIT, ELEMENT, HEATING 1.6KW120V W/ JAM NUT & SILICONE O-RING			
6	WC-1438-101*	SENSOR, TEMPERATURE TANK			
7	WC-4394*	GUARD, SHOCK/HEATING ELEMENT FOR SINGLE HEATING ELEMENT			

¹ Units built 01/04/2019 and later.
² Units built before 01/04/2019. Replaces WC-5527.
 * Recommended parts to stock.

WC-62039/62040/62041 - Tank Assembly (Export)

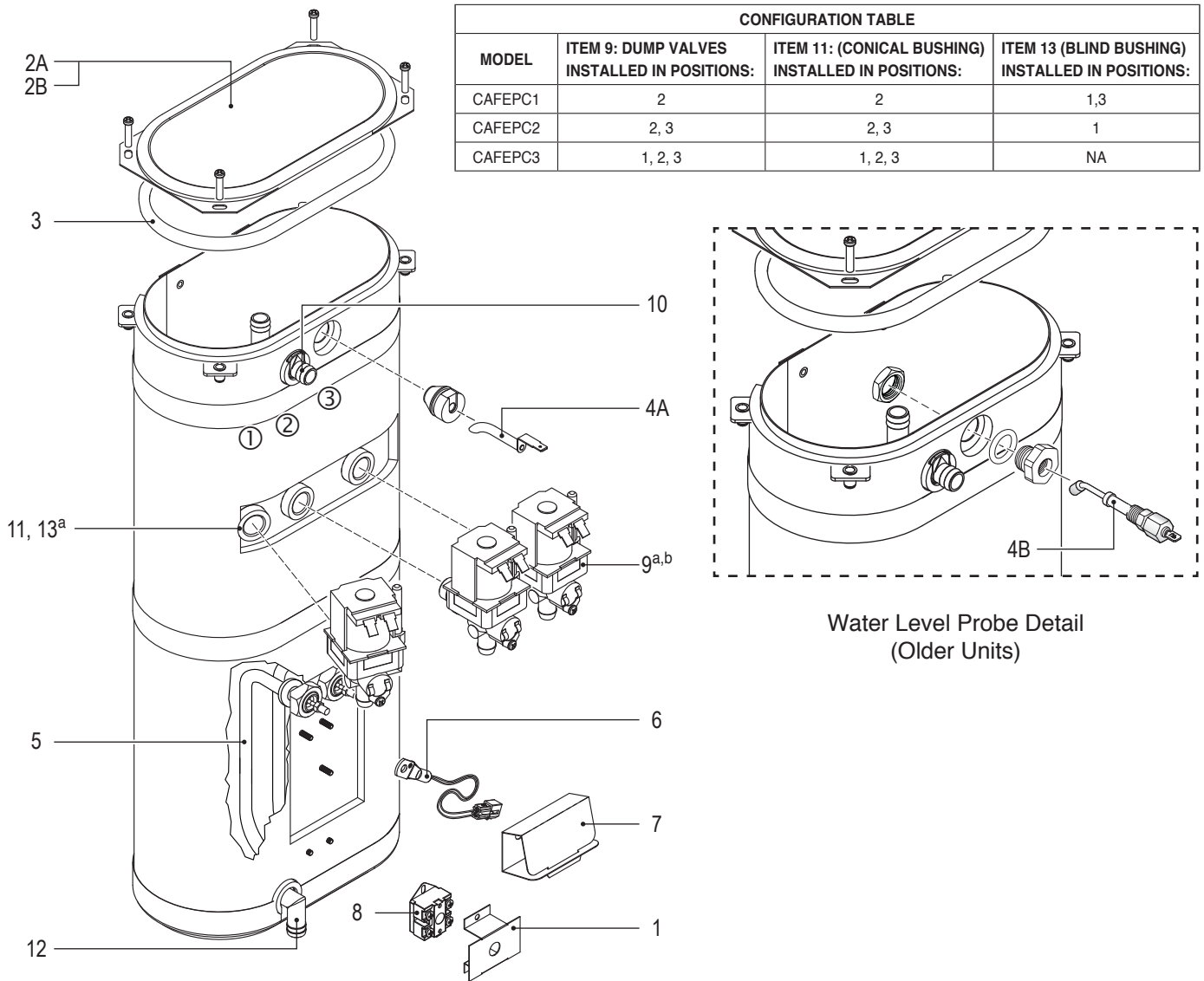

CONFIGURATION TABLE			
MODEL	ITEM 9: DUMP VALVES INSTALLED IN POSITIONS:	ITEM 11: (CONICAL BUSHING) INSTALLED IN POSITIONS:	ITEM 13 (BLIND BUSHING) INSTALLED IN POSITIONS:
CAFEP1	2	2	1,3
CAFEP2	2, 3	2, 3	1
CAFEP3	1, 2, 3	1, 2, 3	NA

^a See CONFIGURATION TABLE.
^b Valve must be calibrated when replaced. See instructions with kit.

WC-62039/62040/62041 - Tank Assembly - Parts List

ITEM #	PART #	DESCRIPTION
1	WC-43055	GUARD, SHOCK RESET THERMOSTAT (WC-522)
2A	WC-5853-102	COVER, TOP HEATING TANK GEN USE
2B	WC-5851	COVER, TANK W/NOTCHES (UNITS BEFORE 3/08)
3	WC-43062*	GASKET, TANK LID
4A ¹	WC-5528K*	KIT, WATER LEVEL PROBE, SILICONE
4B ²	WC-5502-01*	KIT, PROBE, ASSY WATER LEVEL W/HEX FITTING, O-RING & NUT
5	WC-906-04*	KIT, ELEMENT, HEATING 2KW 220V W/ JAM NUT & SILICONE O-RING
6	WC-1438-101*	SENSOR, TEMPERATURE TANK
7	WC-4394*	GUARD, SHOCK/HEATING ELEMENT FOR SINGLE HEATING ELEMENT

ITEM #	PART #	DESCRIPTION
8	WC-522*	THERMOSTAT, HI LIMIT HEATER CONTROL DPST 277V 40A
9	WC-880E*	VALVE, DUMP 120V 12W PC'S
10	WC-37266*	KIT, FITTING TANK OVERFLOW
11	WC-2627*	BUSHING, CONICAL .583ID X .945 OD .886LG 12mm GEN USE
12	WC-37365*	KIT, FITTING TANK INLET
13	WC-2630*	BUSHING, CONICAL BLIND GEN USE

¹ Units built 01/04/2019 and later.
² Units built before 01/04/2019.Replaces WC-5527.
 * Recommended parts to stock.

Domestic Models

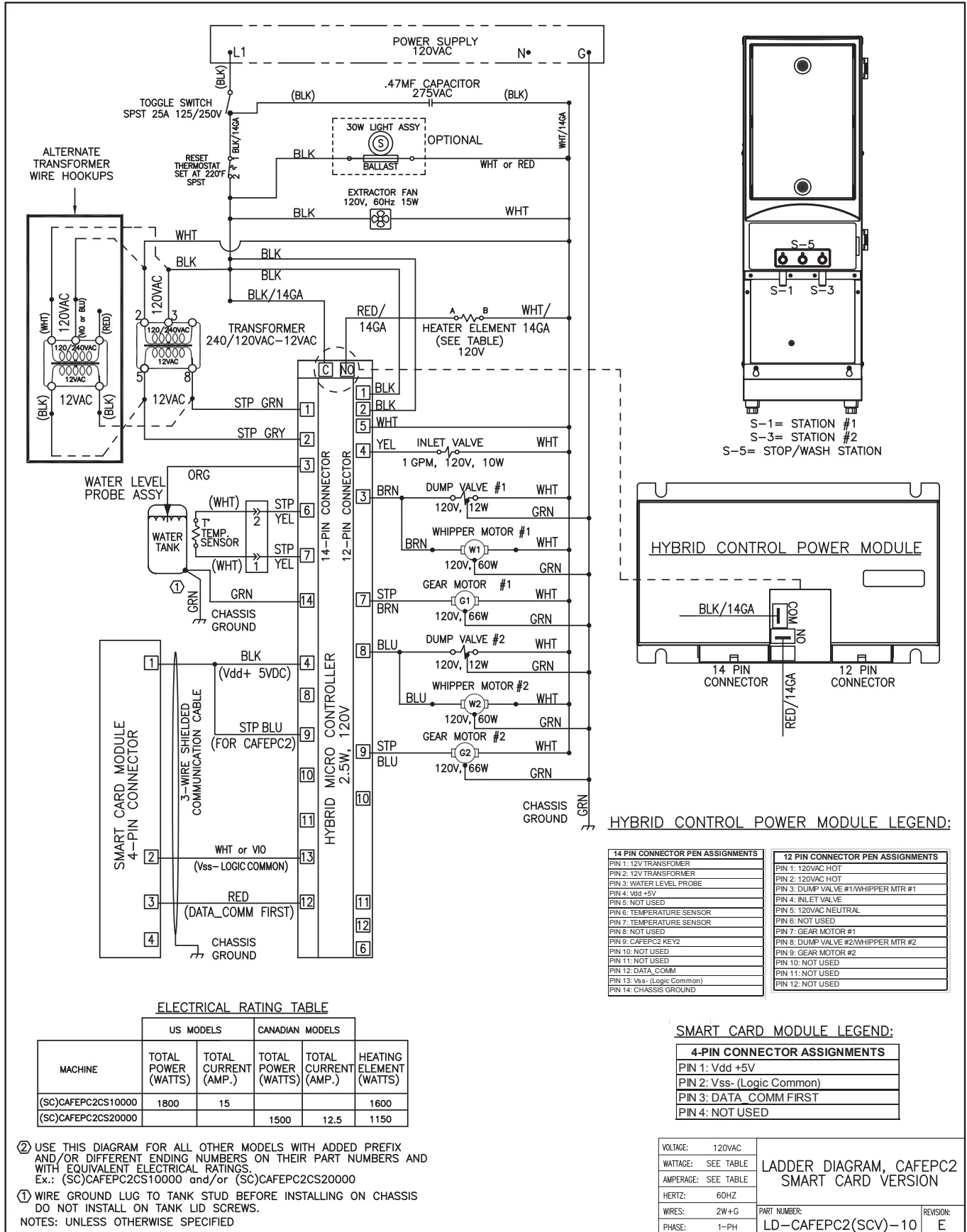

Export Models

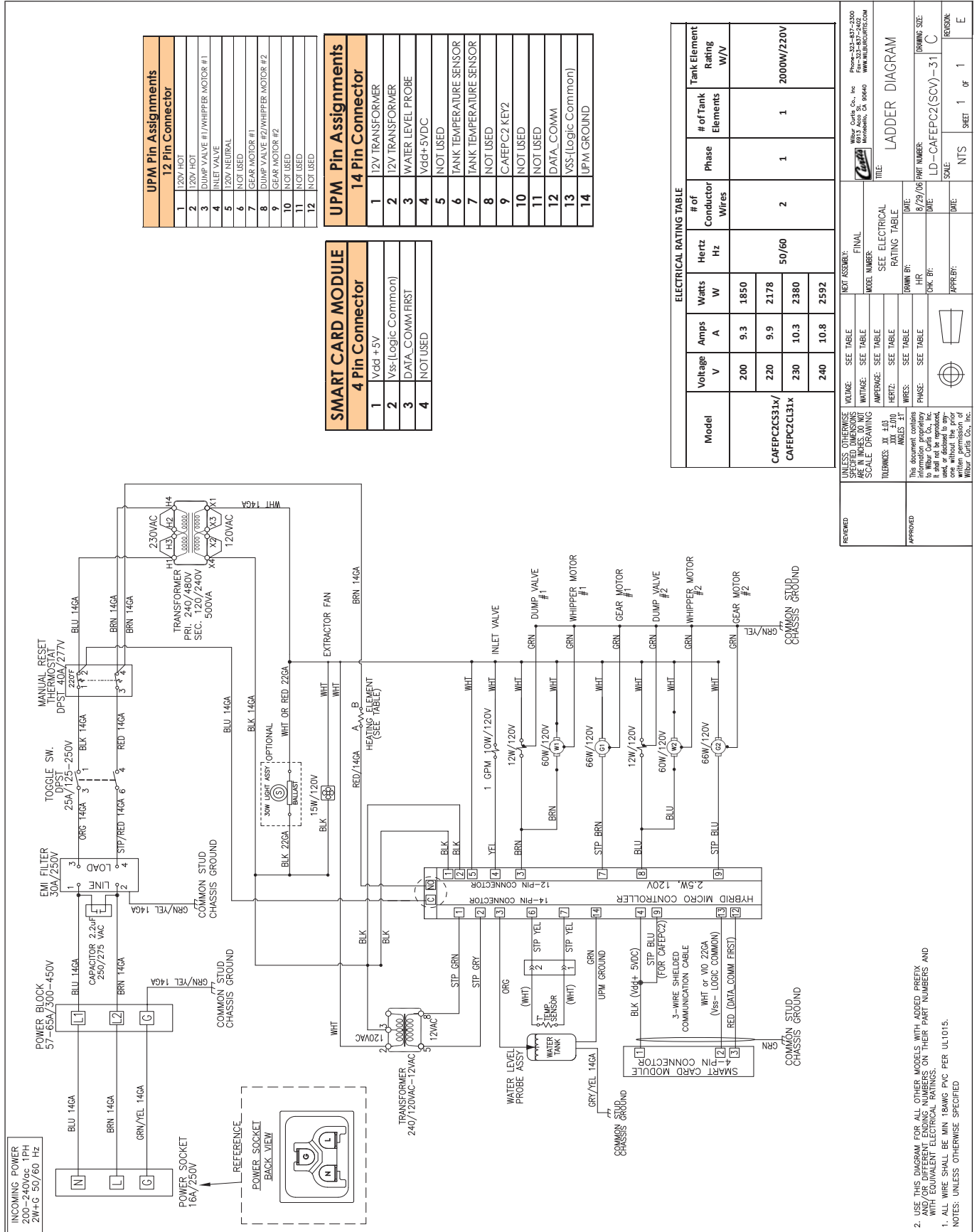

UPM Pin Assignments

12 Pin Connector	
1	120V HOT
2	120V HOT
3	DUMP VALVE #1/WHIPPER MOTOR #1
4	INLET VALVE
5	120V NEUTRAL
6	NOT USED
7	GEAR MOTOR #1
8	DUMP VALVE #2/WHIPPER MOTOR #2
9	GEAR MOTOR #2
10	NOT USED
11	NOT USED
12	NOT USED

UPM Pin Assignments

14 Pin Connector	
1	12V TRANSFORMER
2	12V TRANSFORMER
3	WATER LEVEL PROBE
4	VGGH+5VDC
5	NOT USED
6	TANK TEMPERATURE SENSOR
7	TANK TEMPERATURE SENSOR
8	NOT USED
9	CAFEPC2 KEY2
10	NOT USED
11	NOT USED
12	DATA_COMM
13	VSS-(Logic Common)
14	UPM GROUND

SMART CARD MODULE

4 Pin Connector	
1	VGGH+5V
2	Vss-(Logic Common)
3	DATA_COMM FIRST
4	NOT USED

ELECTRICAL RATING TABLE

Model	Voltage V	Amps A	Watts W	Hertz Hz	# of Conductor Wires	Phase	# of Tank Elements	Tank Element Rating W/V
CAFEPC2CS31X/ CAFEPC2CL31X	200	9.3	1850	50/60	2	1	1	2000W/220V
	220	9.9	2178					
	230	10.3	2380					
	240	10.8	2592					

REVISION

1	INIT ASSEMBLY	FINAL
2	VOLTAGE: SEE TABLE	MODE NUMBER: SEE ELECTRICAL RATING TABLE
3	WATTAGE: SEE TABLE	SCALE: DRAWING
4	AMPERAGE: SEE TABLE	TOLERANCES: XX, ±0.01, ANGLES: 3:1
5	WIRE GAUGE: SEE TABLE	DATE: 8/29/06
6	PHASE: SEE TABLE	CHK. BY: [Signature]
7	APPROVED: [Signature]	DATE: [Date]

APPROVED

UNLESS OTHERWISE SPECIFIED: ALL DIMENSIONS ARE IN INCHES, UNLESS NOTED OTHERWISE. SCALE: DRAWING. TOLERANCES: XX, ±0.01, ANGLES: 3:1. THIS DOCUMENT CONTAINS PROPRIETARY INFORMATION OF WILBUR CORP. CO., INC. IT SHALL NOT BE REPRODUCED, COPIED, OR TRANSMITTED IN ANY FORM OR BY ANY MEANS WITHOUT THE WRITTEN PERMISSION OF WILBUR CORP. CO., INC.

NOTE: USE THIS DIAGRAM FOR ALL OTHER MODELS WITH ADDED PREFIX AND/OR DIFFERENT ENDING NUMBERS ON THEIR PART NUMBERS AND WITH EQUIVALENT ELECTRICAL RATINGS. ALL WIRE SHALL BE MIN 18AWG PVC PER UL1015. NOTES: UNLESS OTHERWISE SPECIFIED

WILBUR CORP. CO., INC.
 8013 Alico St.
 Birmingham, AL 35246
 Phone: 205-837-2300
 Fax: 205-837-5407
 WWW.WILBURCORP.COM

TITLE: LADDER DIAGRAM

DRAWING SIZE: C

SCALE: LD-CAFEPC2(SCV)-31

SHEET: 1 of 1

REVISION: E

**WARNING:**

Electric Shock Hazard - the following procedures are to be performed only by a qualified service technician. Disconnect power when replacing components. Lock out and tag the circuit breaker. Neither Wilbur Curtis Co., Inc. nor the seller can be held responsible for the interpretation of this information, or any liability in connection with its use.

Scald and Burn Hazard - keep body parts clear of hot surfaces during troubleshooting.



IMPORTANT: If it is necessary to replace the micro-controller (HMC)*, always check all inlet and dump valve coils for a short and replace the valve as necessary, before replacing the module. See the **Valve Test Procedure**, below to test for defective valves.

*Referred to as the control power module in the parts list.

Troubleshooting Guidelines

- If the STOP/WASH light is blinking, consult the **ERROR CODES** section before troubleshooting.
- A dispenser that is not level may not function properly. Make sure the unit is properly leveled before proceeding.
- This troubleshooting guide identifies some, but not all, of the possible causes for common problems that can occur.
- Use this troubleshooting guide along with the appropriate **ELECTRICAL SCHEMATIC**.

Valve Test Procedure

Use a digital multi-meter to measure the resistance of valve coils.

Measure the resistance across the valve coil terminals with the wiring harness disconnected. Reverse the meter leads on the terminals and measure the resistance in the opposite direction. A resistance of less than 100 ohms, in either direction, indicates a shorted coil. The valve must be replaced.

If a shorted coil is not detected, test for an open coil:

- 1 Reconnect the valve terminals to the wiring harness.
- 2 Power up the dispenser with the appropriate cover(s) removed to allow access to the valve.
- 3 Run a dispense cycle while monitoring the voltage at the valve coil terminals. If voltage is present on the terminals, you should hear the valve click open/closed at the moment power is applied or removed from the terminals. The inlet valve should open any time the water tank is not full. If the valve does not open, replace it. If voltage is not detected, first check the wiring. If the wiring is OK, check the HMC.

Water Not Hot Enough

- 1 If the water heats, but is not hot enough, first check for the correct temperature setting. See **PROGRAMMING GUIDE**. Reprogram as necessary.
- 2 If the temperature setting is OK, but the actual water temperature does not match the setting on the control panel, replace the temperature sensor.

Water Heats More Slowly Than Usual

- 1 Check for power across the terminals of the heating element(s). If power is being supplied, disconnect the heating element(s) and check for continuity. Replace a heating element if the resistance is too high (nominal resistance is 13 Ohms).
- 2 If there is no power to the heating element(s), check the wiring to any element that does not have the proper voltage across it. Also check for corroded connections anywhere between the power cord and the heating element(s).

Water Does Not Heat At All

- Check to see if the water level in the tank is in contact with the water level probe. If not, see *Tank Does Not Fill*. The water will not heat unless it is in contact with the probe.
- If the water heats, but is not hot enough, see *Water Not Hot Enough*.
- If the ready lights are on above the dispense (PUSH) buttons, but the water is not hot, check the resistance across the leads of the temperature sensor. If the resistance is less than 10 k and the water is not hot, replace the temperature sensor. If the sensor resistance is above 10 k when the water is cool, replace the micro-controller (HMC).

If the STOP/WASH light is on constantly, but the water does not heat, follow the steps below. The following steps are performed with the rear toggle switch in the ON position.

- 1 Check for power across the terminals of the heating element(s). If power is being supplied, remove the wires and check for an open heating element.
- 2 If there is no power to the element(s), trace the circuit back (using the *ELECTRICAL SCHEMATIC*) to the power cord to find out where power is lost.
- 3 If there is power into the HMC, but not out, and the STOP/WASH light is on, replace the HMC.

Water Too Hot (Boiling or Excessive Steaming)



IMPORTANT: If the unit is being operated at elevations above 2000 feet (600 m), before proceeding, make sure that the control panel temperature is set to the factory default setting of 190°F/88°C (100°F/38°C on iced cappuccino units). The boiling point of water goes down with increases in elevation.

- 1 If the STOP/WASH light is on constantly, first check to make sure that the temperature sensor is attached tightly to the tank and that heat sink compound was used. A properly mounted sensor should have a resistance of around 7 k when the water is hot. If not, replace the sensor.
- 2 Check to see if the micro-controller (HMC) constantly supplies power to the heating element, regardless of the resistance of the temperature sensor. If so, the HMC is probably bad.

Temperature Sensor Error

This error indicates a malfunction (open circuit) in the temperature sensor system. Once the malfunction is corrected, the error indication (flashing light) must be cleared. To reset the dispenser and return to normal operation, turn the toggle switch on the back of the unit to the OFF position for 5 seconds, then back ON.

- 1 Check the resistance across the leads of the temperature sensor while it is disconnected from the micro-controller (HMC). If an open circuit is measured (resistance above 200 k), replace the sensor.
- 2 If the sensor resistance is less than 200 k check the sensor wires for corrosion and reconnect them to the HMC. Afterward, if the error indication comes back after resetting the unit, replace the HMC.

No Power - No Lights on Control Panel Come On

- 1 Make sure the circuit breaker to the circuit supplying power to the unit is not tripped and is turned on.
- 2 Make sure the power plug on the unit is connected to the power receptacle.
- 3 Make sure that the main power toggle switch on the back panel is turned ON.
- 4 Verify that all wires from the power cord are properly connected inside the unit. Loose connections create heat. Check to make sure the wires are not burned/overheated. Check chassis ground.
- 5 Check to make sure power and ground are being supplied to the micro-controller (HMC). If there is power into the HMC, but no lights on the smart card module (SCM), check the wiring between the SCM and the HMC. If the wiring is OK, the SCM or HMC may be bad.
- 6 If there is no power into the HMC, trace the circuit back (using the *ELECTRICAL SCHEMATIC*) to the power cord to find out where power is lost. If there is power into the thermostat reset switch, but not out, see step 7.
- 7 If there is power into the thermostat reset switch, but not out, check to make sure that the water tank is not empty. If the tank is empty, the reset switch has probably opened up due to a low water level, go to *Water Tank Does Not Fill*. If there is water in the tank, but no power out of the reset switch, push in on the reset switch button to see if it restores power. If power is restored, check to make sure that the switch is not opening up at the wrong temperature (the switch should not open up at normal operating water temperatures). If there is still no power through the switch after pushing the button, replace the thermostat reset switch.

Water Tank Overfills

- 1 Turn the toggle switch on the back of the unit ON and OFF. If water continues to flow when the switch is in both positions, replace the inlet valve.
- 2 If water stops flowing to the water tank when the toggle switch is turned OFF and continues when the switch is turned back ON, remove the orange wire from the water probe on the tank. While power is ON, short the end of the orange wire to the metal surface on the outside of the tank. If the water tank stops filling when the orange wire is shorted to the tank, check for a corroded connection at the water probe.
- 3 If water does not stop flowing when the orange wire is shorted to the tank, check the tank ground connection and the continuity of the orange wire connecting to the micro-controller (HMC). If both are OK, replace the HMC.

Water Tank Does Not Fill

IMPORTANT: No water or low water in the tank can cause the tank to overheat, resulting in the thermostat reset switch opening. If after correcting a tank fill problem there is no power to the control panel, push the reset switch button to reset.

- 1 Check to make sure the water supply is turned on. Check for a plugged water supply line, clogged water filter or plugged inlet valve.
- 2 If there are no plugs in the water supply line, check for power across the inlet valve terminals. If power is being supplied, but there is no water flow, replace the inlet valve.
- 3 If power is not being supplied to the inlet valve, check the wires between the micro-controller (HMC) and the inlet valve. Check for corroded connections.
- 4 If the wiring between the HMC and the inlet valve is OK, but there is no power to the inlet valve, remove the orange wire from the water tank probe. If the water tank starts to fill, replace the water probe. If the water tank does not start to fill, replace the HMC.

Water Level Error

Water level fill error or overflow. This error occurs when the inlet valve solenoid has been on too long during initial fill or tank refill. See the **ERROR CODES** section for the maximum times allowed. Once the malfunction is corrected, the error message must be cleared. To reset the unit and return to normal operation, turn the toggle switch on the back of the unit to the OFF position for 5 seconds, then back ON.

- 1 Make sure that the water supply valve is completely open and that the water filter is not clogged. Check to make sure that the flow rate from the water supply line meets the minimum flow rate specifications for the dispenser. Also check the water pressure. See the **SPECIFICATIONS** section.
- 2 Check for blockage at the inlet valve inlet or outlet. Check for blockage in the tubing between the inlet valve and the water tank.
- 3 Check the water probe wire for an open condition or corroded connections.
- 4 If the probe connections are OK, cycle power to the unit by turning the rear toggle switch OFF, then ON. Check to see if power is applied to the inlet valve terminals. If power is applied to the terminals, but there is no water flow, replace the inlet valve.
- 5 Check for power from the micro-controller (HMC) to the inlet valve. If the wiring is OK, replace the HMC.

Water Flows From Dispenser Spout Constantly

- 1 Check to see if water continues to flow from the spout when the toggle switch is turned OFF. Replace any valve that is stuck open.
- 2 If one or more of the valves mentioned in step 1 turns on when the toggle switch on the back is ON and turns off when the switch is OFF, replace the micro-controller (HMC).

No Water Flows From the Spout While PUSH Button is Pushed

Condition: Whipper motor runs and powder comes out of the spout, but no water:

- 1 Check to see if power is being supplied to the associated dump valve when the dispense button is pushed. If power is being supplied, but there is no water flow, replace the valve.
- 2 If power is not being supplied to the dump valve during the dispense cycle, first check the wiring from the micro-controller (HMC) to the valve.
- 3 If the wiring is OK, check for power output from the HMC while the dispense button is being pushed. Replace the HMC if there is no power out.

Cup Not Filled To Normal Level During Dispensing or Overflows

Check to make sure that the smart card module (SCM) preset dispense setting is correct. See **PROGRAMMING GUIDE**.

Only Water is Dispensed

Condition: Water flows and whipper motor runs, but NO powder is dispensed.

- 1 Check to see if the canister is empty.
- 2 Check to see if the powder is damp, which will inhibit powder flow. Moisture build up inside the canister can be due to an exhaust fan not working. Check to make sure that the fan is getting power and/or that the fan is turning.
- 3 Check to make sure that the Powder % Ratio is not set too low. See **PROGRAMMING GUIDE**.
- 4 Remove the canister. Push the dispense button and check to make sure that the canister gear at the back of the compartment is turning. If it is, check for a stripped gear on both the canister and on the gear motor shaft. If the gears are OK, check the canister auger assembly and make sure that the auger motor is getting power from the micro-controller (HMC).

Product Dispensed Into Cup is Weak



IMPORTANT: Dump valves should NOT be field adjusted to change product strength. Product strength adjustments should be done through programming on the front panel only. See *PROGRAMMING GUIDE*.

Condition: Water flows and whipper motor runs, but amount of powder flow is too low.

- 1 Check to see if the canister is full.
- 2 Check to see if the powder is damp, which will inhibit powder flow. Moisture build up inside the canister can be due to an exhaust fan not working. Check to make sure that the fan is getting power and/or that the fan is turning.
- 3 Check to make sure that the Powder % Ratio is properly set. See the *PROGRAMMING GUIDE* section.
- 4 Check for a stripped gear on both the canister and on the gear motor shaft. If the gears are OK, check the canister auger assembly and make sure the auger motor is getting power from the micro-controller (HMC).

Whipper Motor Does Not Run During Dispensing

Condition: Whipper motor does not run, but water and powder are flowing when the dispense button is pushed.

- 1 Check to see if power is being supplied to the associated whipper motor when the dispense button is pushed. If power is being supplied, but the motor does not run, replace it.
- 2 If power is not being supplied to the whipper motor during the dispense cycle, first check the wiring from the micro-controller (HMC) to the motor.
- 3 If the wiring is OK, check for power output from the HMC while the dispense button is being pressed. Replace the HMC if there is no power out.

Ready Lights are On, But Dispenser Does Not Respond (at all) When Dispense Button is Pushed

Check for faulty wiring and connections between the smart card module (SCM) and the micro-controller (HMC). If the wiring is OK, but NOTHING happens suspect the smart card (SCM) or the HMC.

Dispenser Overflows During Dispensing

Units set to manual dispense mode: Make sure that the operation is releasing the dispense button when the cup is 3/4 full.

Units set to preset dispense mode: Check the preset dispense setting. See *PROGRAMMING GUIDE*.

Front Panel Light Not Working (Units Equipped with a Light Box)

Check to make sure power is being supplied to the light fixture (power switch on back of unit must be on). If power is being supplied to the light but it does not come on, replace the light assembly.

Dump Valve Calibration

After installing a new dump valve, do not reinstall the dump valve cover and canisters, so that you can perform the calibration steps below:

- 1 Turn the toggle switch on the back of the unit to the ON position. Wait for the ready light to come on.
- 2 Place a measuring cup below the spout connected to the dump valve that was replaced.
- 3 Push the DISPENSE button for the spout connected to the dump valve that was replaced. Time the flow rate.* Water should flow at a rate of 7 oz. (8 oz. Max) in 10 seconds. If the flow rate is OK, skip to step 6. If the flow rate is too high or too low, perform the steps that follow.
- 4 Open the door on the front of the unit. Using a 6 mm hex wrench, turn the adjustment screw on the front of the valve one half turn. Turn counterclockwise to increase the flow rate or clockwise to decrease.
- 5 Close the door and recheck the flow rate. If the flow rate is 7 oz. (8 oz. Max) in 10 seconds, replace the dump valve cover and canisters. If the flow rate is still out of calibration, repeat steps 4 and 5 until the flow rate is correct.
- 6 Replace the dump valve cover and canisters when the flow rate is correct to return the unit to normal use.

*All PCGT series units, except Pre-Set Dispense models, are equipped with a valve calibration feature that dispenses water for 10 seconds, eliminating the need for manual timing. See the *Programming Guide* section.

System Fault Messages

- The control board is equipped with an error code system. It is designed to quickly advise you of certain problems the dispenser may experience, expediting service or repair. Error codes are indicated by the STOP/WASH light on the control panel flashing one of the patterns shown below. Any dispenser service must be performed by a qualified service technician.
- Error codes are reset by turning the rear toggle switch to the OFF position for a minimum of 10 seconds, then back ON.
- Occasionally, an error code may be caused by a problem with the water supply or electrical power that is NOT directly associated with a fault in the unit itself. For example, a clogged water filter may cause a water level error code.

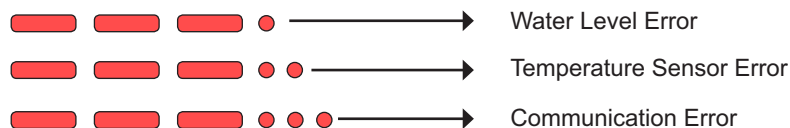

**Error Codes
(STOP/WASH Light)**

ERROR MESSAGE	WARNING DESCRIPTION	CAUSE
Water Level Error	Fill run error/overflow	The water inlet valve has either been open for more than 10 minutes on the initial tank fill or has been open for more than 30 seconds in normal operation.
Temperature Sensor Error	Open temperature sensor	Break in the temperature thermistor.
Communication Error	Communication error	Break in the communication wires between the control boards.

Wilbur Curtis Co., Inc. certifies that its products are free from defects in material and workmanship under normal use. The following limited warranties and conditions apply:

- 3 years, parts and labor, from original date of purchase on digital control boards
- 2 years, parts, from original date of purchase on all other electrical components, fittings and tubing
- 1 year, labor, from original date of purchase on all other electrical components, fittings and tubing

Additionally, Wilbur Curtis Co., Inc. warrants its grinding burrs for four (4) years from the date of purchase. Stainless steel components are warranted for two (2) years from the date of purchase against leaking or pitting. Replacement parts are warranted for ninety (90) days from the date of purchase or for the remainder of the limited warranty period of the equipment in which the component is installed.

All in-warranty service calls must have prior authorization. For authorization, call the Technical Support Department at 800-995-0417. Additional conditions may apply. Go to www.wilburcurtis.com to view the full product warranty information.

CONDITIONS & EXCEPTIONS

The warranty covers original equipment at time of purchase only. Wilbur Curtis Co., Inc., assumes no responsibility for substitute replacement parts installed on Curtis equipment that have not been purchased from Wilbur Curtis Co., Inc. Wilbur Curtis Co., Inc. will not accept any responsibility if the following conditions are not met. The warranty does not cover:

- **Adjustments and cleaning:** *The resetting of safety thermostats and circuit breakers, programming and temperature adjustments are the responsibility of the equipment owner. The owner is responsible for proper cleaning and regular maintenance of this equipment.*
- **Replacement of items subject to normal use and wear:** *This shall include, but is not limited to, spray heads, faucets, light bulbs, shear disks, "O" rings, gaskets, silicone tubing, silicone elbows, canister assemblies, whipper chambers and plates, mixing bowls, agitation assemblies and whipper propellers.*

The warranty is void under the following circumstances:

- **Improper operation of equipment:** *The equipment must be used for its designed and intended purpose and function.*
- **Improper installation of equipment:** *This equipment must be installed by a professional technician and must comply with all local electrical, mechanical and plumbing codes.*
- **Improper voltage:** *Equipment must be installed at the voltage stated on the serial plate supplied with this equipment.*
- **Improper water supply:** *This includes, but is not limited to, excessive or low water pressure and inadequate or fluctuating water flow rate.*
- **Damaged in transit:** *Equipment damaged in transit is the responsibility of the freight company and a claim should be made with the carrier.*
- **Abuse or neglect (including failure to periodically clean or remove lime accumulations):** *The manufacturer is not responsible for variation in equipment operation due to excessive lime or local water conditions. The equipment must be maintained according to the manufacturer's recommendations.*
- **Unauthorized repair or modification:** *This equipment must be serviced only by qualified service technicians, using factory specified parts to factory specifications.*
- **Modified/Missing Serial Tag:** *The serial number label (tag) must not be defaced or removed.*

Repairs and/or Replacements are subject to Curtis' decision that the workmanship or parts were faulty and the defects showed up under normal use. All labor shall be performed during regular working hours. Overtime charges are the responsibility of the owner. Charges incurred by delays, waiting time, or operating restrictions that hinder the service technician's ability to perform service is the responsibility of the owner of the equipment. This includes institutional and correctional facilities. Wilbur Curtis Co., Inc. will allow up to 100 miles, round trip, per in-warranty service call.

Return Merchandise Authorization (RMA): All claims under this warranty must be submitted to the Wilbur Curtis Technical Support Department prior to performing any repair work or return of this equipment to the factory. **All returned equipment must be properly re-packaged in the original carton and received by Curtis within 45 days following the issuance of a RMA.** No units will be accepted if they are damaged in transit due to improper packaging. **NO UNITS OR PARTS WILL BE ACCEPTED WITHOUT A RETURN MERCHANDISE AUTHORIZATION (RMA). THE RMA NUMBER MUST BE MARKED ON THE CARTON OR SHIPPING LABEL. All warranty claims must be submitted within 60 days of service. Invoices will not be processed or accepted without a RMA number. Any defective parts must be returned in order for warranty invoices to be processed and approved.** All in-warranty service calls must be performed by an authorized service agent. Call the Wilbur Curtis Technical Support Department to find an agent near you.