



CAFE PRIMO CAPPUCCINO SYSTEMS

TROUBLESHOOTING GUIDE



PARTS IDENTIFICATION

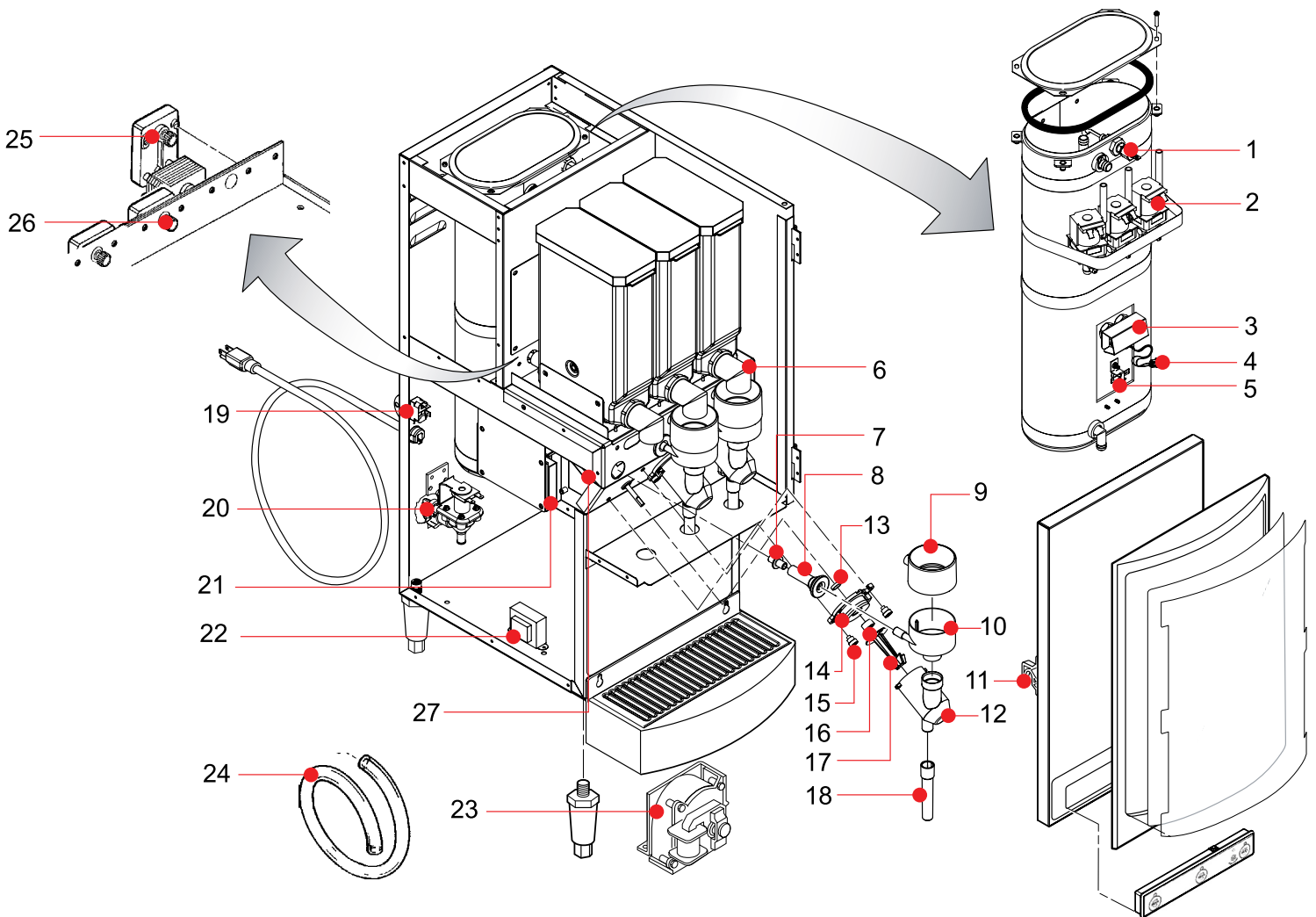

PART #	DESCRIPTION	PART #	DESCRIPTION
1. WC-5502-01	KIT, PROBE, ASSY WATER LEVEL W/HEX FITTING, O-RING & NUT	14. WC-37118	KIT, WHIPPER PLATE (3/PKG)
2. WC-3734	KIT, DUMP VALVE 120V 12W	15. CA-1024-05	PILLAR, LOCATION BLACK
3. WC-904-04	HEATING ELEMENT 1600W 120V W/JMNUT	16. CA-1076-04	SEAL, WHIPPER PLATE 20/PKG
4. WC-1438-101	SENSOR, TEMPERATURE TANK	17. CA-1008-07K	KIT, PROPELLER WHIPPER 6/PKG OFFSET BLD
5. WC-521	SWITCH, #4680 VESSEL LIMIT	18. CA-1037-3Y	TUBE, EXTENSION YELLOW
6. CA-1026-03	ELBOW, CANSITER	19. WC-102	SWITCH, TOGGLE NON-LIT 25A 120/240VAC
7. CA-1095	CONNECTOR, ORIFICE WATER	20. WC-826L	VALVE, INLET 1GPM 120V 10W
8. CA-1011-05	BULKHEAD, WATER FITTING	21. WC-782K	CONTROL POWER MODULE CAFE PC
9. CA-1005-03	STEAM TRAP	22. WC-718-101	TRNSFRMR ASSY, 240/120VAC-12VAC 500mA
10. CA-1009-03	MIXING BOWL	23. WC-37123	FAN, EXTRACT 120V 29 CFM & BRACKET
11. CA-1135	LATCH ASSEMBLY DOOR SIDE MOUNT	24. WC-5310	TUBING, 5/16" ID x 1/8" W SILICONE
12. CA-1006-06	CHAMBER, WHIPPER OFFSET PCGTs	25. WC-37174	KIT, GEAR MOTOR & GEAR
13. WC-43791	RING, MOTOR SHAFT PLASTIC	26. CA-1036	GEAR, PLASTIC
		27. WC-3739	WHIPPING MOTOR

PARTS IMAGES

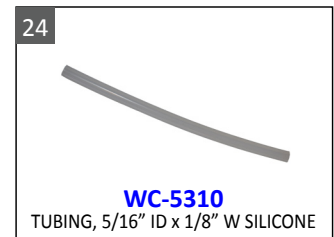
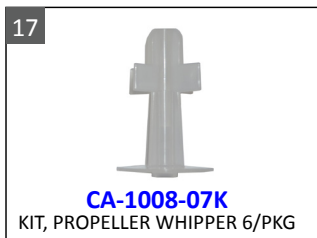
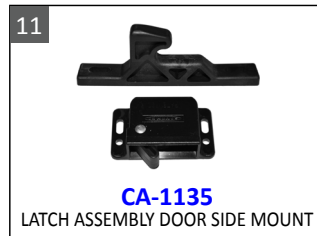
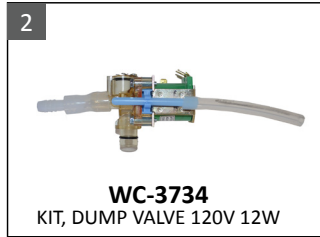

TROUBLESHOOTING INSTRUCTIONS

POWER ISSUES

The LED light on the front door are not lit:

- 1 Verify that the panel breaker is turned on. If okay, proceed STEP 2.
- 2 Verify that the voltage at the receptacle is correct: L1-N = 120 vac, N-G = 0 vac. if okay, proceed to STEP 3.
- 3 Verify that the toggle switch is turned on. Verify 120 vac on both terminals.

No: Replace Toggle Switch
Yes: Proceed to STEP 4
- 4 Verify that there is 120 vac on both sides of the Reset Thermostat, measuring between L1-N.

No: Replace Reset Thermostat
Yes: Proceed to #5

- 5 Verify that there is 12 vac between pins 1 & 2 on the 14 pin connector at the UPM and 120 vac between pins 1 & 2 on the 12 pin connector at the UPM.

No: Replace transformer.
Yes: Verify 5 vdc between pins 1 & 2 on the 4 pin connector at the Smart Card Module.

No: Replace UPM
Yes: Replace Smart Card Module

HEATING ISSUES

Not heating:

Is the water level in the tank in contact with the water level probe?

Yes: Verify 120 volts at the Heating Element.

Yes: Replace the element. If there is not 120 volts at the heating element:

Verify that the tank is calling for heat. Is the Wash light illuminated? If yes, replace the UPM. If the Wash light is not illuminated:

Verify that the resistance on the temp sensor is over 100k Ohm, if not, replace the temp sensor.

i If the water in the tank is not in contact with the probe – refer to tank filling issues. The unit will not heat until the water in the tank has contacted the probe.

Overheating:

Is the “Stop/Wash” light on?

Yes: Check relay on UPM for continuity and replace UPM if relay is closed.

No: Verify that resistance on temp Sensor reads less than 10k ohm. Verify correct mounting to tank. Replace sensor.

TANK FILLING ISSUES

Not filling:

Is the water turned on?

Yes: Verify 120 volts at inlet valve coil

Yes: Replace Inlet Valve

No: Remove Orange wire from the Water Level Probe. Does the Tank Fill?

Yes: Replace Water Level Probe.

No: Replace UPM

Overfilling:

Does the tank continue to fill after the toggle switch has been turned off ?

Yes: Replace Water Inlet Valve.

No: Remove the Orange wire from the Water Level Probe and connect it to ground. Does the tank stop filling?

Yes: Replace the Water Level Probe

No: Replace the UPM

DISPENSING ISSUES

Powder not being dispensed on any selection:

Verify that the wiring to the Auger Motors is correct. If the wiring is correct and unbroken, replace the UCM / Smart Card (shorted wash button)

Powder not being dispensed from a single selection:

Verify that the canister has sufficient product.

Verify that the Auger Motor has 120 volts.

If yes, replace the Auger Motor. If the Auger Motor does not have 120 Volts, replace the UPM.

Not dispensing water on a single selection:

Verify that the dispense valve has 120 volts.

If yes, replace the dispense valve. If the dispense valve does not have 120 volts, replace the UPM.

Whipper Motor not running:

Verify that the propeller and chamber are assembled correctly (not binding).

Verify that the Whipper Motor has 120 volts. If yes, replace the whipper motor. If the Whipper Motor does not have 120 volts, verify that the wiring is correct and unbroken. If so, replace the UPM.

i If the Dispense valve on the same selection is operating, the UPM does not need to be replaced. The Whipper Motor and Dispense valve are powered together by the UPM.



Wilbur Curtis Co., Inc.

6913 Acco Street, Montebello CA 90640
Customer Service: 800.421.6150 | 323.837.2300
csrassistance@wilburcurtis.com
Tech Support: 800.995.0417
www.wilburcurtis.com