



Service Manual – Combo Brewer High Volume Single

Models

- CBHVS
- CBHVS200

Important Safeguards/Conventions

This appliance is designed for commercial use. Any servicing other than cleaning and preventive maintenance should be performed by an authorized Wilbur Curtis service technician.

- Do NOT immerse the unit in water or any other liquid
- To reduce the risk of fire or electric shock, do NOT open service panels. No user serviceable parts inside.
- Keep hands and other items away from hot surfaces of unit during operation.
- Never clean with scouring powders, bleach or harsh chemicals.

Symbols



WARNINGS – To help avoid personal injury



Important Notes/Cautions – from the factory



Sanitation Requirements

The Curtis High Volume Combo Brewer is Factory Pre-Set and Ready to Go... Right from the Box.

Following are the Factory Settings for the High Volume Combo Brewer:

- Brew Temperature = 200°F
- Water Bypass = On LARGE & MEDIUM brew only
- Brew Volume = Large set to vessel requirements.

System Requirements:

- Water Source 20 – 90 PSI (Minimum Flow Rate of 1 GPM)
- Electrical: See schematic on page 9.

SETUP STEPS

The unit should be level (left to right and front to back), and located on a secure counter top. Connect a water line from the water filter to the brewer.

NOTE: A water filtration device must be used to maintain a trouble-free operation. (In areas with extremely hard water, we suggest that a sedimentary and taste & odor filter be installed.) This will prolong the life of your brewing system and enhance coffee quality.





NSF International requires the following water connection:

1. A quick disconnect or additional coiled tubing (at least 2x the depth of the unit) so that the machine can be moved for cleaning underneath.
2. In some areas an approved backflow prevention device may be required between the brewer and the water supply.
3. Water pipe connections and fixtures directly connected to a potable water supply shall be sized, installed and maintained in accordance with federal, state, and local codes.

1. A 1/4" Flare x 3/8" Male pipe elbow is supplied with the brewer for water line connection. Use tubing sized sufficiently to provide a minimum of 1.0 GPM.
2. Connect the unit to an appropriate electrical power circuit.
3. Turn on the toggle (STANDBY/ON) switch behind the unit. The heating tank will start to fill. When the water level in the tank rises to the correct volume, the heating elements will energize automatically. With this coffee brewer, there is no risk of heating element burnout caused by overheating an empty tank.
4. The heating tank will require 20 to 30 minutes to reach operating temperature (200°F), indicated when READY TO BREW is displayed on the LCD screen.
5. Prior to brewing, dispense 12 ounces of hot water through the hot water faucet.
6. Brew a cycle of at least 12 ounces, to purge the water lines of any air that may be trapped after filling.

 **CAUTION:** Please use this setup procedure before attempting to use this brewer. Failure to follow the instructions can result in injury or the voiding of the warranty.

 **IMPORTANT:** Equipment to be installed to comply with applicable federal, state, or local plumbing/electrical codes having jurisdiction.

 **CAUTION:** DO NOT connect this brewer to hot water. The inlet valve is not rated for hot water.

ISO 9001:2008 REGISTERED

WILBUR CURTIS CO.
Montebello, CA 90640
For the latest information go to
www.wilburcurtis.com
Tel: 800/421-6150

Coffee Brewing Instructions

1. Brewer should be ON (Confirm at rear toggle switch, then press the ON/OFF button). Ready-to-Brew should be on the display.
2. Place an empty coffee container under the brewcone.

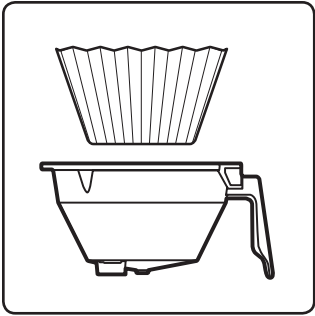

3. Place a clean filter into the brewcone marked "COFFEE".

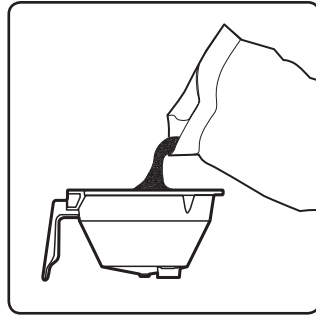

4. Fill brewcone with the proper amount of ground coffee.

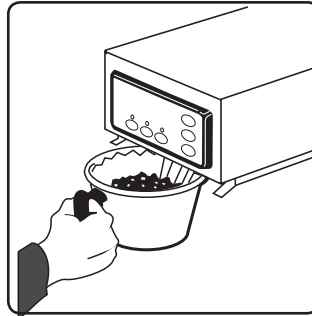

5. Slide brewcone into brew rails. Place a Satellite under brewcone

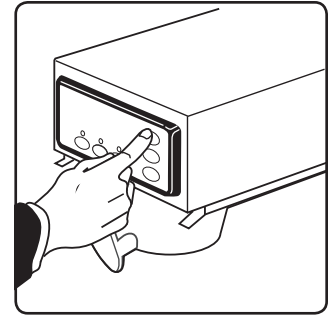

6. Press Brew button. Brewing will begin immediately.



WARNING TO AVOID SCALDING, Do not remove brewcone while brew light is flashing.

Tea Brewing Instructions

1. Brewer should be ON (Confirm at rear toggle switch, then press ON/OFF button) and Ready-to-Brew displayed.
2. Make sure tea container is in place.

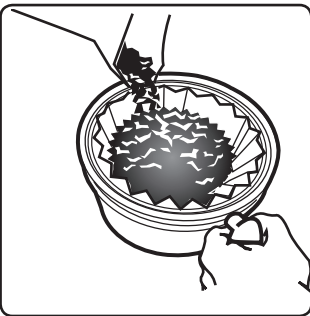

3. Place filter in brew basket. Pour leaf tea into basket marked ICED TEA.

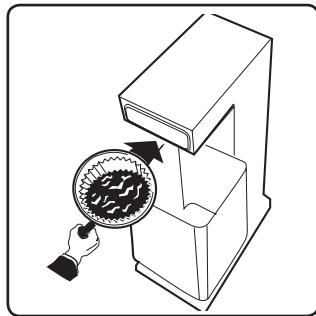

4. Slide brew cone into brew rails. Place tea container under brew cone.

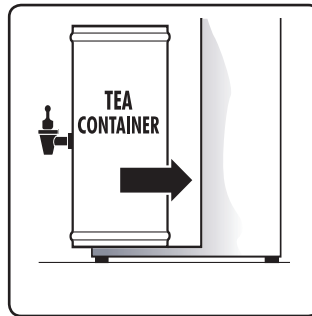

5. Slide container all the way in against the center wrap.

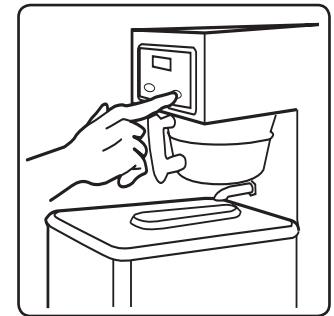

6. Press the TEA BREW button.

Quick Start

CBHVS

Your Curtis G3/Gold Cup Series is Factory Pre-Set for Optimum Performance.

After connection to water and power; the rear toggle switch must be on. You will hear a beep sound, indicating power is available to the controller.

The control displays **CURTIS** Press ON/OFF button and the screen will display **<CBHVS> CURTIS** After three seconds, **CURTIS FILLING** displayed.

Water will fill the tank (approximately 2-3 minutes depending on water flow rate). When the proper level is reached **CURTIS HEATING** will appear on the screen. It takes approximately 20 minutes to reach set point temperature.

Control will display **CURTIS READY TO BREW** when temperature reaches the set point. Unit is now ready to brew.

Programming with the Universal Control Module (UCM)

Turn off the control panel by pressing ON/OFF button. Press and hold bottom/right coffee brew button (#4 in illustration) and then press and release the ON/OFF button.

Continue holding the bottom-right brew button. The screen will display **ENTERING PROGRAM MODE**, wait until **ENTER CODE** is displayed. Enter the 4-digit access code, the code corresponds to the buttons illustrated below. The default code set at the factory is 1-2-3-4.

After the 4-digit code is entered, **PROGRAM MENUS < SELECT >** will be displayed. You can now enter the program menu features.

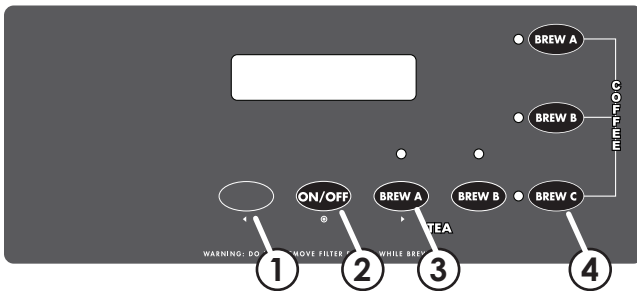

All programming selections are performed with the three center buttons. The symbols near the buttons are:

- ◀ Scroll LEFT
- ⊙ SELECTION or ENTER to save new parameter
- ▶ Scroll RIGHT

Program Menus Combo Brewer

Program Menus

From **Program Menus** press > display will show the next feature Global Recipes.

Global Recipes

Global Recipes (Factory set to Gourmet STD)

This is a coffee option. Press ⊙ to select. If selected, press < or > to chose a coffee recipe: Gourmet STD, Light Roast, Dark Roast, High Yield, Filter Pack, or Decaf. Press ⊙ to select the desired recipe.

Non-Brew Program

Non-Brew Program

Press ⊙ to Select or < > to pass by these options and continue to the next group. The selections for Non-Brew Program are listed below.

Coffee Temperature

Coffee Temperature (Factory set to 200°F)

Press ⊙ to Select. Press < or > to move to desired temperature and then ⊙ to set. Temperature is programmable from 170°F to 208°F in 2-degree increments.

Tea Temperature

Tea Temperature (Factory set to 204°F)

Press ⊙ to Select. Press < or > to move to desired temperature and then ⊙ to set. Temperature is programmable from 170°F to 208°F in 2-degree increments.

Energy Save Mode

Energy Save Mode (Factory set to OFF)

Press ⊙ to Select, < or > ON, OFF or ON 140°F, ⊙ to set. When in ON, unit will automatically shut off 4 hours from last brew. When feature is OFF, unit does not utilize the energy saving mode.

In the ON 140°F position, temperature lowers to 140°F, if unit has not brewed in 4 hours. This feature will save energy by maintaining a lower temperature in the tank in periods of non-operation.

Brew Count Odom

Brew Count Odom

Press ⊙ to display total brew cycles. Press EX or Reset.

Brew Count Total	<p>Brew Count Total Press ⊙ to Select, Shows total gallons and total brew cycles on the unit. Not resettable.</p>
Cold Brew Lock	<p>Cold Brew Lock . . . (Factory set to 5°) Press ⊙ to select, < or > to select desired setting (CBL 5, 15 or OFF), ⊙ to set. The Cold Brew Lock feature allows the brewer to brew at three different temperature levels from the actual set point. The first setting is within 5 degrees of set point, next is within 15 degrees of set point, OFF is within 30 degrees of set point for the Ready to Brew message, however, it will brew at any temperature.</p>
Master Reset	<p>Master Reset Press ⊙ to display Are You Sure? Then < for Yes, > for No. Brewer factory defaults are then reset.</p>
Service Call	<p>Service Call (Phone number Factory set to 1-800-000-0000 X0000) Press ⊙ to display number and change number or < to move place and EX to exit when complete. This number will be displayed during a Heating system SENSOR ERROR or during a WATER ERROR.</p>
Access Code	<p>Access Code (Factory set to 1-2-3-4) Press ⊙ to display number and change number, (the number can be changed 1 to 4) or < to move place and EX to exit when complete.</p>
Banner Name	<p>Banner Name (Factory set to CURTIS) Press ⊙ to display letters and change letters or < to move place and EX to exit when complete This feature allows up to 14 letters to be programmed for company name or regional name. Programming all blanks disables Banner Name. If programmed, Banner Name is displayed every 5 sec. on and off.</p>
P-Maintenance	<p>P-Maintenance (Factory set to OFF) Press ⊙ to Select, Set gallons brewed to indicate P-Maintenance. Press < or > to adjust from Off to 9500 gallons. This feature advances in 500 gallon increments. Press ⊙ to exit.</p>
Beeper On/Off	<p>Beeper On/Off (Factory set to ON) Press ⊙ to display ON or OFF. Pressing either < or > toggles between on and off. ⊙ to set. When ON, this feature allows you to hear a short beep each time a button is pressed.</p>
Coffee Drip-out Mode	<p>Coffee Drip-out Mode (Factory set to 2 minutes) Press ⊙ to Select. Press < or > to move to desired time. Settings are OFF, 1, 2, 3, 4 and 5 minutes. Press ⊙ to Select time.</p>
Tea Drip-out Mode	<p>Tea Drip-out Mode (Factory set to 2 minutes) Press ⊙ to Select. Press < or > to move to desired time. Settings are OFF, 1, 2, 3, 4 and 5 minutes. Press ⊙ to Select time.</p>
Displ. Brew Time	<p>Displ. Brew Time (Factory set to ON) Press ⊙ to display ON or OFF. Pressing either < or > toggles between on and off. After Display Brew Time an EXIT screen will return you to Brew Button Prog.</p>
Brew Button Prog	<p>Brew Button Program This is the next group of options in the sequence. The screen will prompt you to choose tea or coffee. Coffee options are shown below. Tea option are shown on page 5.</p>
Select Button	<p>Select Button This is a temporary screen message indicating you are in the coffee brew button programming mode. Select a coffee brew button on the control module.</p>
Brew By Volume	<p>Brew by Volume (Factory settings: LARGE 200oz ±8oz. MEDIUM 132oz±4oz. SMALL 64oz±4oz.) Press ⊙ to Select. Display will ask you to select a brew button, Large, Medium or Small. Press the desired brew button to begin... when desired volume is reached press the same brew button to stop the flow. Now the volume has been set.</p>
Brew By Time	<p>Brew by Time (Factory settings: LARGE 5min-25sec. MEDIUM 3min-32sec. SMALL 1min-52sec.) Next item in the sequence is Brew by Time. Press ⊙ to Select to change the brew time. Display will now show the current time. By pressing < or > you can toggle back and forth from minutes to seconds to exit (ex). Change the time or set and exit by pressing the ⊙ button.</p>

Pre-infusion	<p>Pre-Infusion (Factory Disabled) Press ⊙ to Select. Current setting in seconds is displayed < to decrease or select > to increase (range from OFF to 10 through 60 seconds), ⊙ to set. If Pre-infusion is selected (ON), Cold Brew Lock is set to Delta 1 within 5°F of set point and Cold Brew Lock disappears from the list of program selections. When Pre-infusion is ON, Pulse Brew disappears from the list of program selections.</p>
Pulse Brew	<p>Pulse Brew (Factory setting C) Press ⊙ to select, < or > to select OFF or one of five pulse patterns (A to E) . The five Pulse Brew options help “tune” or change the coffee flavor. Guidelines for Pulse Brew: Filter Pack type coffees typically extract better with the A and B pulse setting. Decaf coffees typically extract better with the B pulse setting. High-Yield coffees typically extract better with the C pulse setting. Of course, any of the A, B or C settings may be used to suit your taste profile. Settings D and E are manual pulse counts. To exit from the Pulse Brew mode, select 0 for the time. If Pulse Brew is on, Cold Brew Lock is set to Delta 1 within 5°F of set point and Cold Brew Lock disappears from the list of program selections. When Pulse Brew is on, Pre-infusion disappears from the list of program selections.</p>
By-Pass	<p>By-Pass (Factory settings: LARGE 35%. MEDIUM 10%. SMALL Off.) The By-Pass option helps with controlling extraction with larger brews. Contact time that is too long will extract undesirable bitter, harsh flavor compounds. By-passing some of the brew water around the coffee bed will balance the extraction. Press ⊙ to display current setting. Press < or > to change settings; OFF, 5% to 50%, in 5% increments. Press ⊙ to set.</p>
Select Button	<p>Select Button – You may select a tea brew button to program from the buttons on the control module.</p>
Tea By Volume	<p>Tea by Volume: Press ⊙ to Select. The display will read Select Brew Button! Once the desired brew button is selected, the display will read Press BREW to Start and hot water starts dispensing. When the desired volume is reached, press FULL BREW again to stop the flow. The brew volume has now been set. When EXIT is displayed, Press ⊙ to select and exit.</p>
Tea By Time	<p>Tea by Time. Press ⊙ to Select. Press < or > to increase or decrease time. Tea by Time has a range of 0:00 to 9:59 (Increments are minutes and seconds). The HALF BREW button will be set at half the brew time.</p>
Tea Dilut. Delay	<p>Dilution Delay Press ⊙ to Select. Press < or > to toggle between Standard-Gray (30 sec), Standard-Purple (30 sec), Tropical-Gray (9 min), Tropical-Purple (9 min), 76/308-Gray (4 min) and 76/308-Purple (4 min). Range is from 0 seconds, 30 seconds to 10 minutes; in 30 second increments.</p>
Tea Dilut. Volume	<p>Dilution Volume Press ⊙ to Select, Display will now show Push START To Begin... Press the BREW button then water starts running, when desired volume is reached press BREW button again to stop the flow. Now the volume has been set. Pressing > button will display the subsequent menu features.</p>
Tea Dilut. Time	<p>Dilution Time Press ⊙ to Select. Press < or > to toggle between Standard-Gray (4min-5sec), Standard-Purple (4min-5sec), Tropical-Gray (4min-26sec), Tropical-Purple (4min-26sec), 76/308-Gray (4min-55sec) and 76/308-Purple (4min-55sec). Dilution Time is from 30 sec to 9 min, 59 sec.</p>
Tea Pulse Brew	<p>Tea Pulse Brew (Factory set to OFF). Press ⊙ to Select, press < or > to choose ON, OFF, or D. Selecting ON will give a pulsing pattern of 1 to 20 pulses. In D, the pulse time can be set for ON, 5 to 150 seconds (adjustable in 5 sec increments). Off time 5 to 150 seconds, adjustable in 5 second increments.</p>
Sweetener Time	<p>Sweetener Time Sweetener Time is only for brewers with the optional tea sweetening system. Press ⊙ to Select. Press < or > to toggle between minutes, seconds or exit. Pressing select ⊙ to choose minutes will increase the minutes. Press ⊙ to add minutes. Press < or > to move to seconds or exit. Setting the time to zero (0) will disable the Sweetener Time feature.</p>

Model Select

Model Select (Factory set to CBHV-Single)

Press **⊙** to select, < or > to select model. The selections are: CBHV-Twin, CBHV-Single, CBHV-Twin SW, and CBHV-SingleSW. Press **⊙** to set. When the Model Select feature is changed, all settings are reset to the defaults of the newly selected model.

Batch Select (Coffee)

Batch Select (Factory set to Three Batch)

This feature will give you a choice to select one, two, or three active brew buttons per brew head. At this time, select only Three Batch. The selections are: One Batch, Two Batch or Three Batch.

Tea Recipes

Tea Recipes (Factory set to Standard - Amber)

This is a tea feature. Press **⊙** to select. If selected, press < or > to chose a tea recipe: Standard - Amber, Tropical - Amber, or 76/308 - Amber. Press **⊙** to select the desired recipe.

Control Module Menu Tree

The flow chart displays the sequence of menu item that can be accessed through the UCM. Various menu items will immediately exit the programming mode when selected. Other menu items, when selected, will continue to the next item in the menu list.

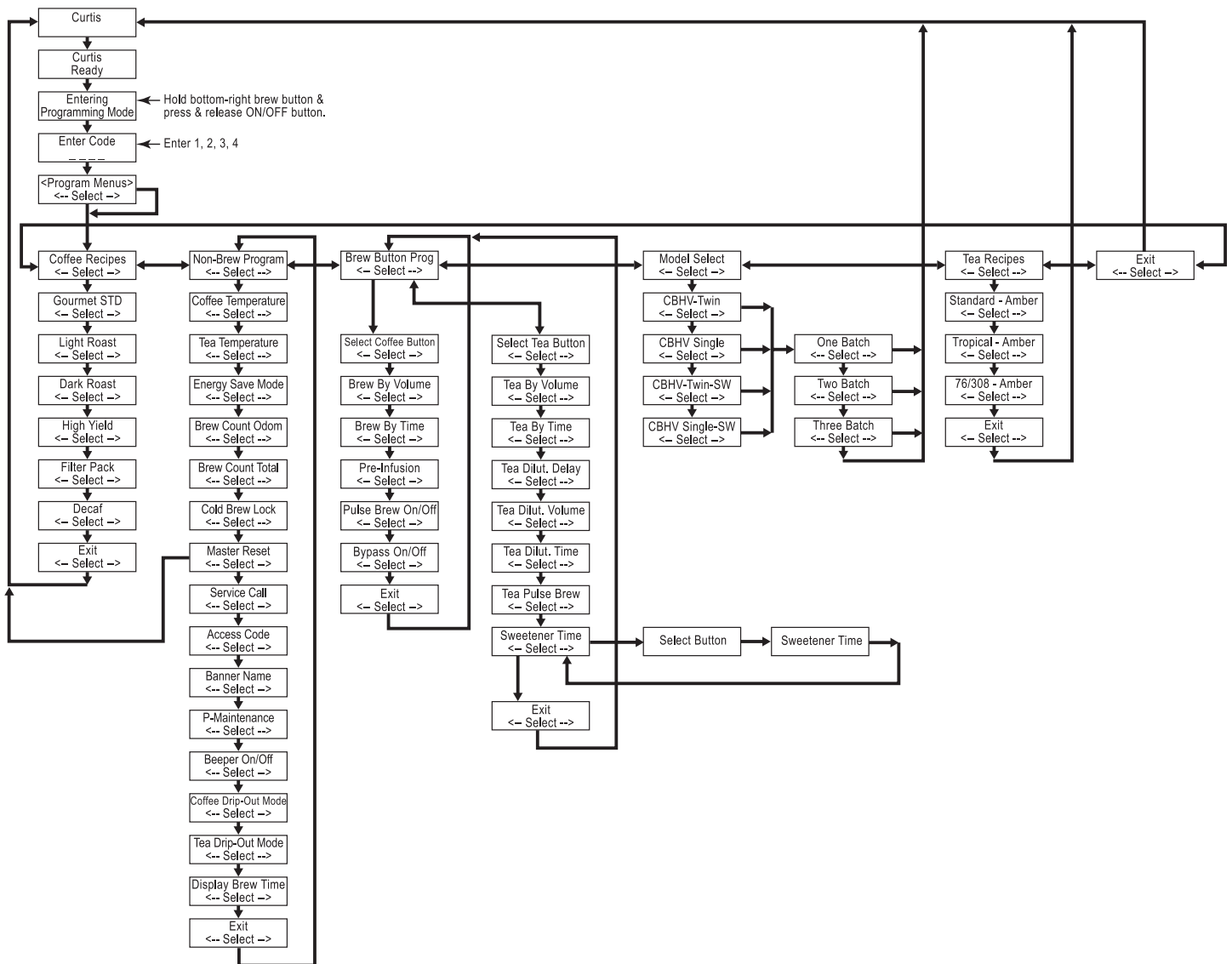

Illustrated Parts List

Curtis High Volume Combo Coffee & Tea Brewer

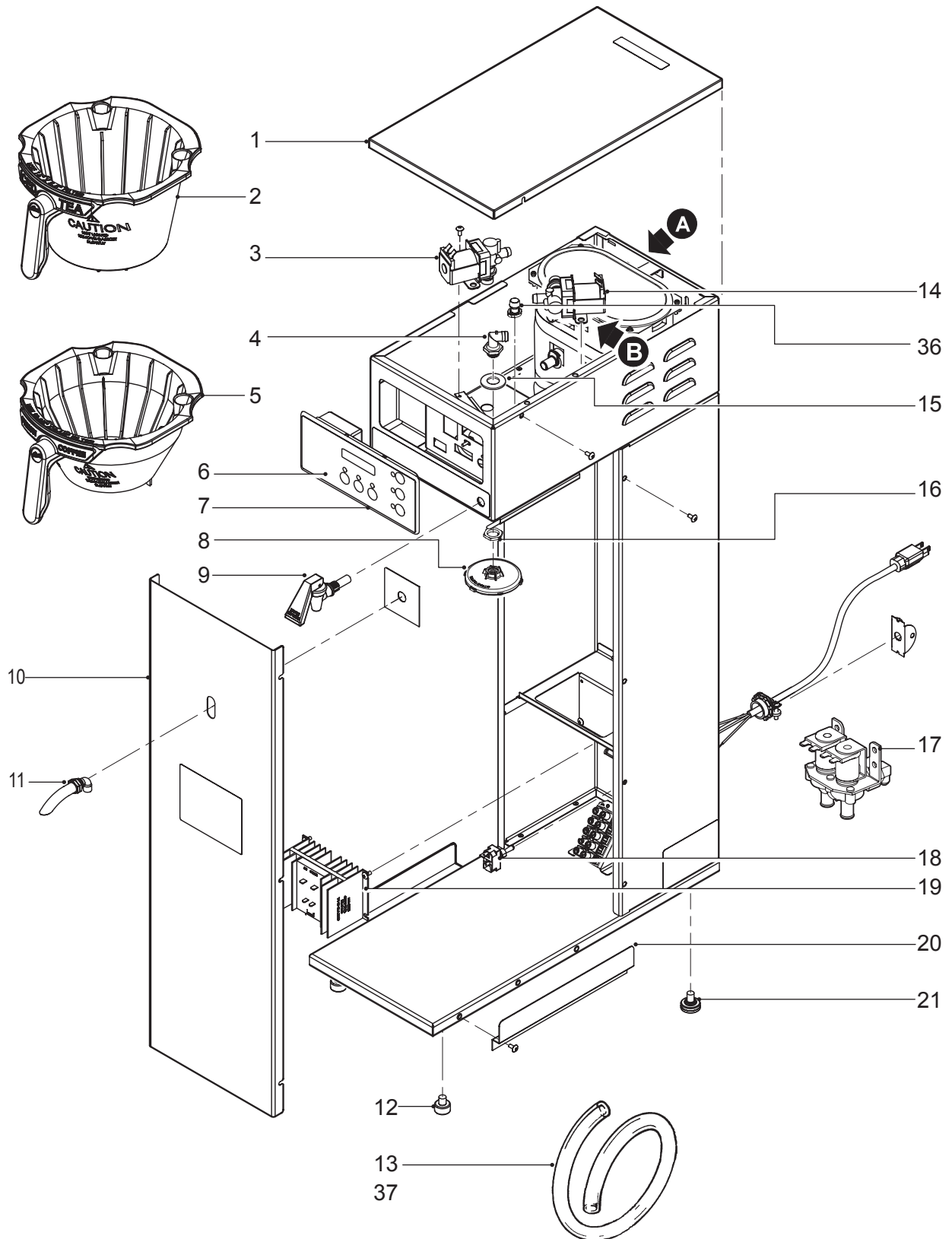

Illustrated Parts List – Detail Bubbles

Curtis High Volume Combo Coffee & Tea Brewer

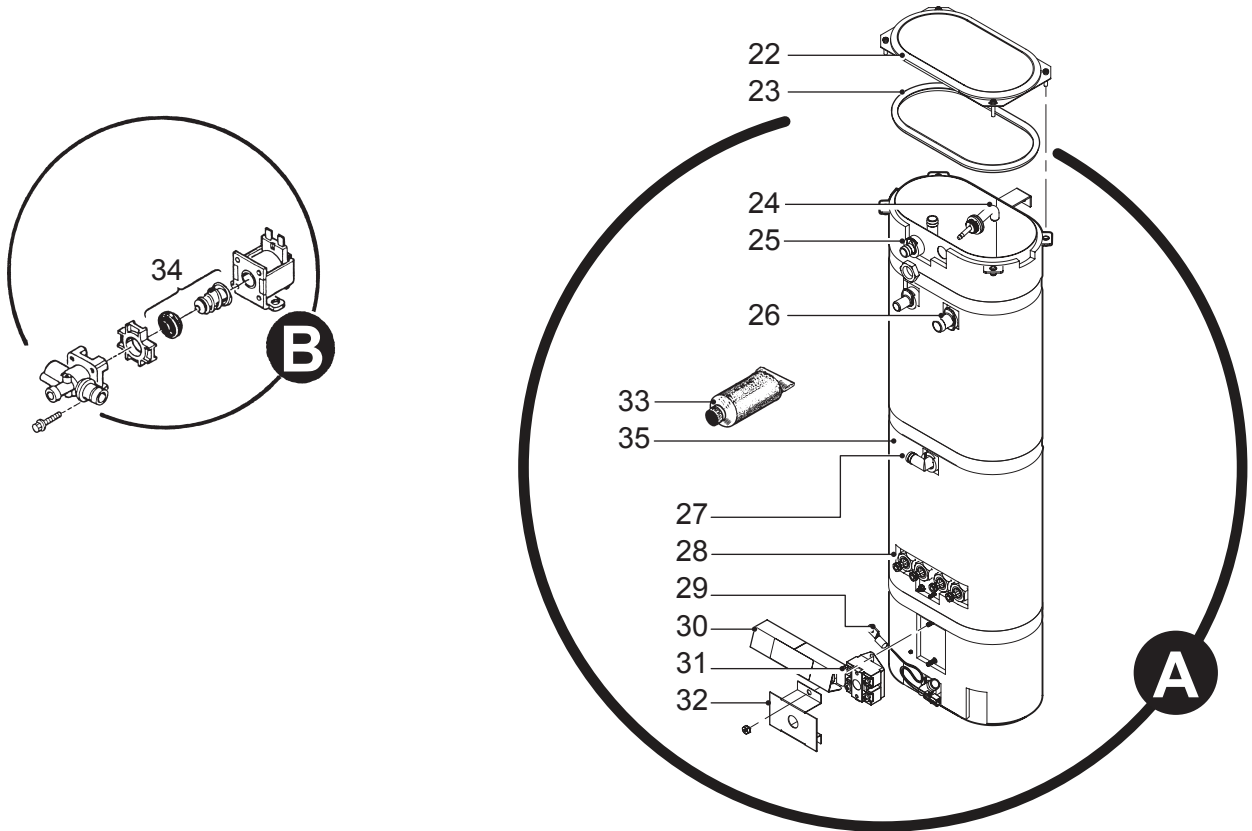

Illustrated Parts List

Curtis High Volume Combo Coffee & Tea Brewer

ITEM	PART N ^o	DESCRIPTION
1	WC-58117	COVER, TOP BREWER
2	WC-37256	BREW CONE, GOURMET NON-METAL TEA UNITS
3	WC- 844-101*	VALVE, BY-PASS 120V-14W NON-ADJUST W/RESTRICTOR
4	WC-2977-101*	FITTING, SPRAYHEAD ULTEM
5	WC-37308*	BREW CONE, BLACK NON-METAL W/COFFEE LABELS
6	WC-39846	LABEL, UCM OVERLAY COMBO SINGLE
7	WC-37403*	KIT, UCM & LABEL CBHVS 3-BATCH
8	WC-29050*	SPRAYHEAD, AMBER ADVANCED FLOW
9	WC-1809	FAUCET, HOT WATER
10	WC-61607	COVER, FRONT
11	WC-2965	SPOUT, BY-PASS ASSEMBLY
12	WC-3503	LEG, 3/8"-16 STUD SCREW BUMPER
13	WC-5310*	TUBING, 5/16" ID x 1/8"W SILICONE
14	WC-37122*	KIT, DUMP VALVE RIGHT 120V 12W
15	WC-43089*	GASKET, 1.00 OD X .625 ID X .030" THK RED SILICONE
16	WC-4212-02	NUT, 5/8-18 JAM PLASTIC ULTEM
17	WC- 895-105*	VALVE, INLET DUAL 120V 10W 2 GPM X .5 GPM
18	WC- 102*	SWITCH, TOGGLE SPST 15A 125VAC RESISTIVE
19	WC-8559*	RELAY, SOLID STATE W/INTEGRATED HEATSINK

ITEM	PART N ^o	DESCRIPTION
20	WC-8531	RAIL, BASE
21	WC-3518*	LEG, GLIDE 3/8"-16 STUD SCREW
22	WC-5853-102	COVER, TOP HEATING TANK
23	WC-43062*	GASKET, TANK LID
24	WC-37406*	KIT, LIQUID LEVEL PROBE FAIL-SAFE, NON-METAL
25	WC-37266	KIT, TANK OVERFLOW FITTING INCLUDES BUSHING
26	WC-37317	KIT, STRAIGHT FITTING INCLUDES BUSHING
27	WC-37365	KIT, TANK INLET FITTING INCLUDES BUSHING
28	WC- 904-04*	KIT,ELEMENT, HEATING 1.6KW/120V W/JAM NUTS
29	WC-1438-101*	SENSOR, TEMPERATURE TANK
30	WC-4394	SHOCK GUARD, HEATING ELEMENT
31	WC- 522*	THERMOSTAT, HI LIMIT HEATER CNTRL DPST 277V 40A
32	WC-43055	SHOCK GUARD, THERMOSTAT
33	WC-5231*	COMPOUND SILICONE 5 OZ
34	WC-37132*	KIT, VALVE (FOR WC-820WDR,WC-821WDR, WC-844WDR)
35	WC-62031	TANK, COMPLETE TP2S DV ULTEM FITTINGS
36	WC-29044	SLEEVE, OVERFLOW ASSY GEN USE
37	WC-5350	TUBE, SILICONE Ø1/2" ID x Ø3/4" OD x 1/8" WALL

* Recommended parts to stock

Illustrated Parts List – Sweet Tea Option
 Curtis High Volume Combo Coffee & Tea Brewer

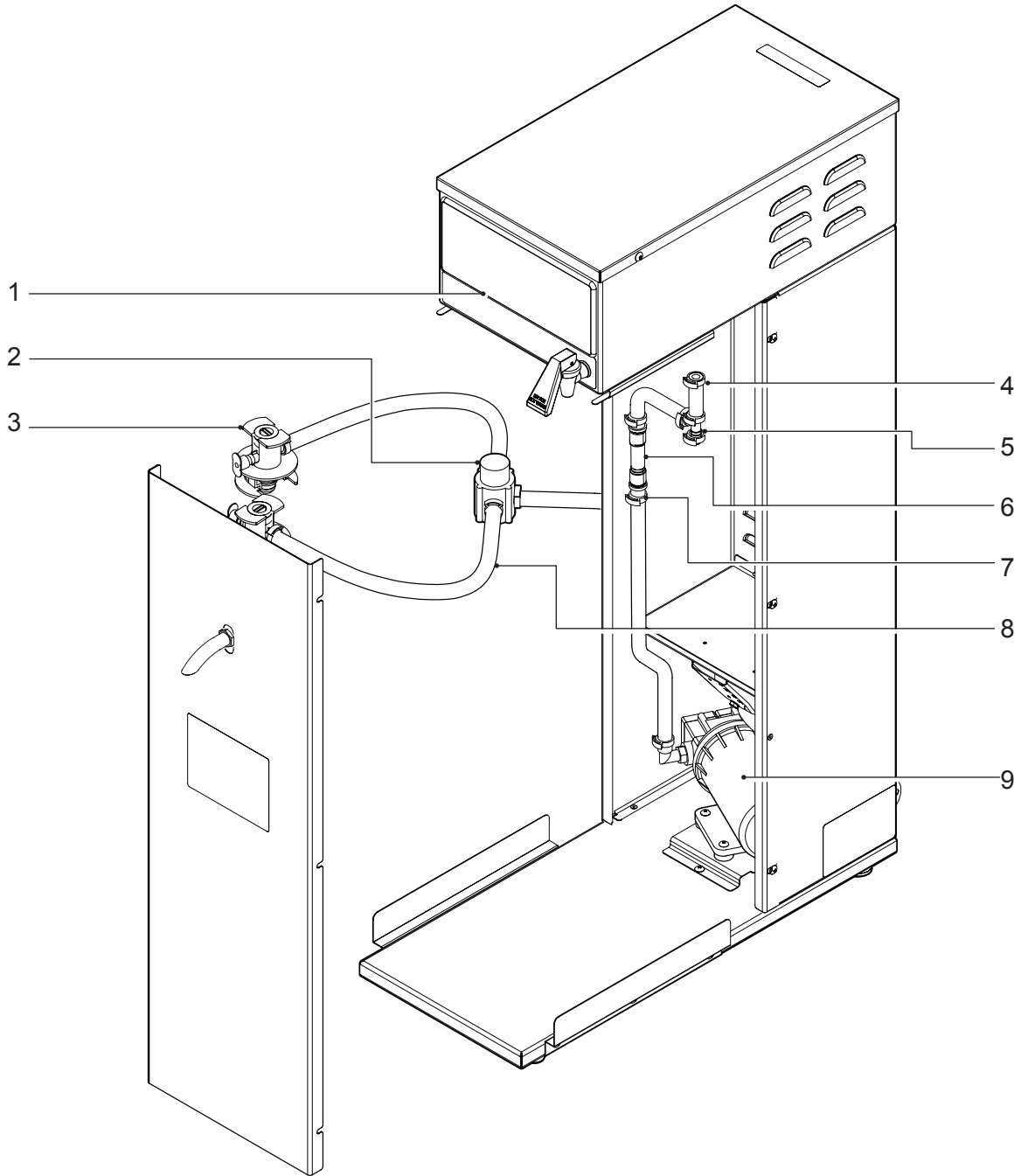

Parts List – Sweet Tea Option
 Curtis High Volume Combo Coffee & Tea Brewer

ITEM	PART N°	DESCRIPTION
1	WC-37405	KIT, UCM & LABEL CBHV SWEET TEA
2	WC-800	VALVE, TRANSFER FLOJET SWEET TEA OPTION
3	WC-8653	QCD, LIQUID BOX BAG CONNECTOR
4	WC-43059	CLAMP, HOSE SNAP NYLON .616-.707
5	WC-29046	TEE, PLASTIC INLET

ITEM	PART N°	DESCRIPTION
6	WC-2452	VALVE, CHECK 3/8 OD TUBE x 3/8 OD TUBE JOHN GUEST
7	WC-2445	STEM, 3/8 BARB x 3/8 STEM
8	WC-53116	TUBE, CLEAR BEV 3/8 SWEETENER SYSTEMS
9	WC-37313	KIT, SWEETENER PUMP AND FITTINGS

Electrical Schematic

Combo Brewer

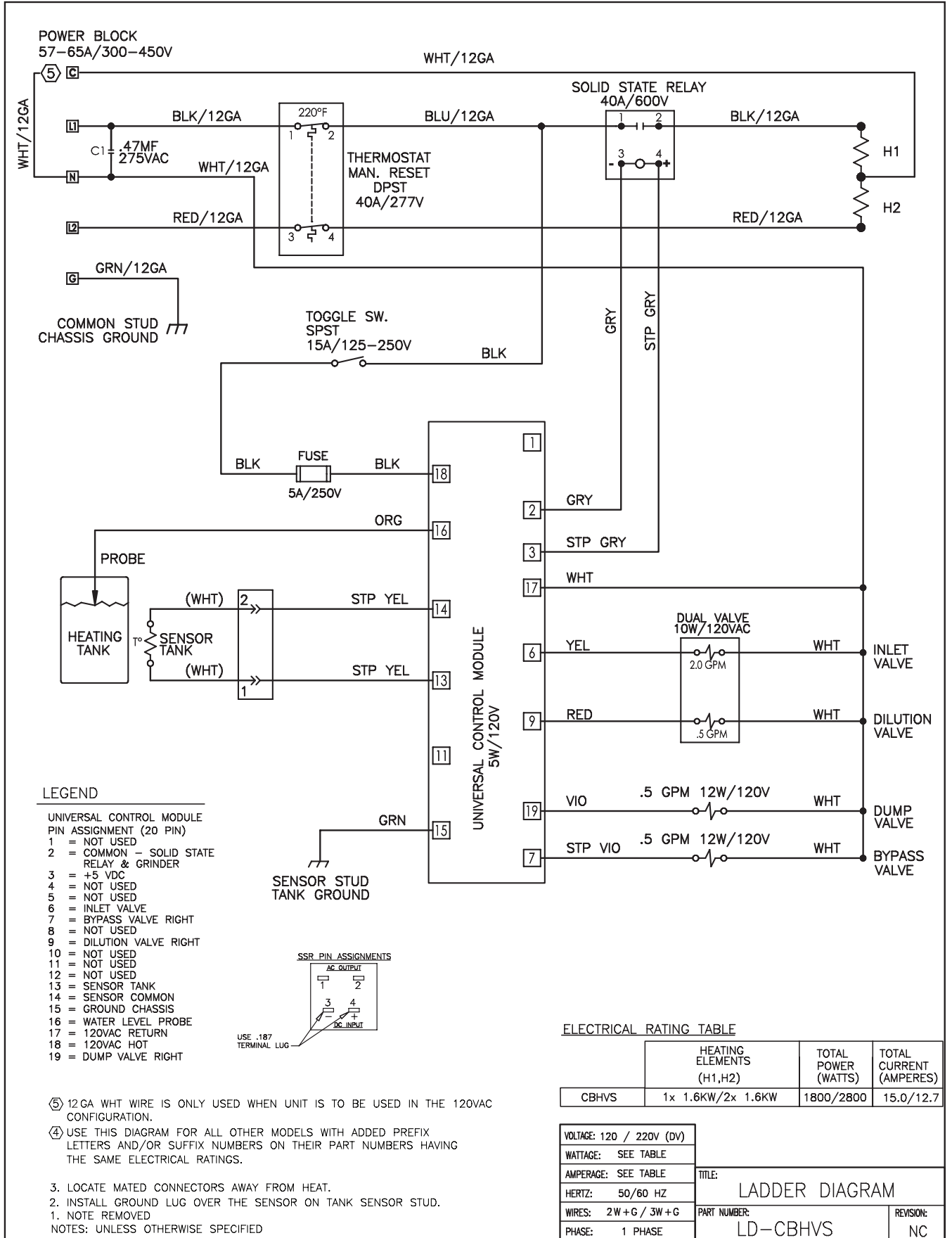

Electrical Schematic

Combo Brewer With Sweet Tea Option

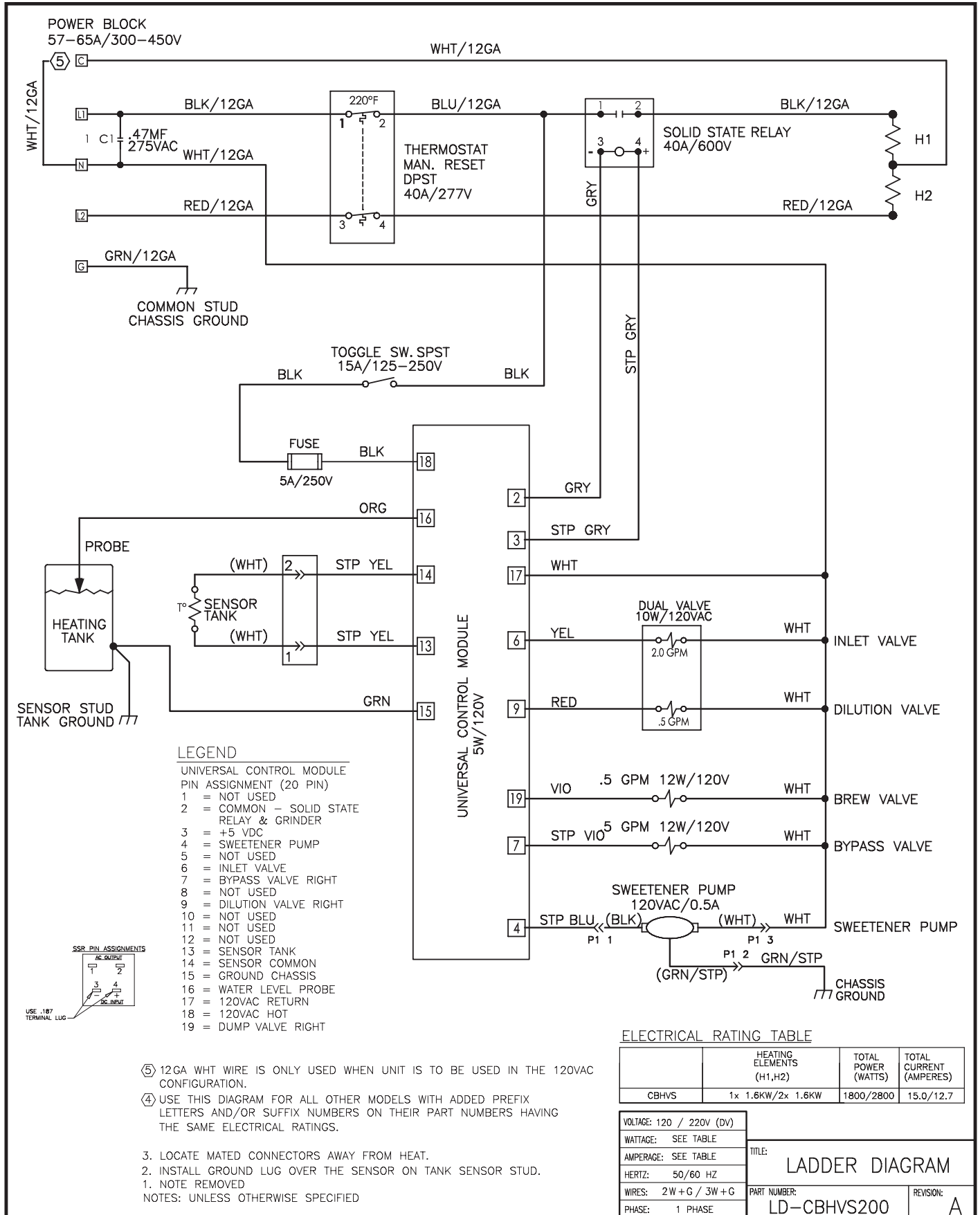

Rough-In Drawing

Curtis High Volume Combo Coffee & Tea Brewer

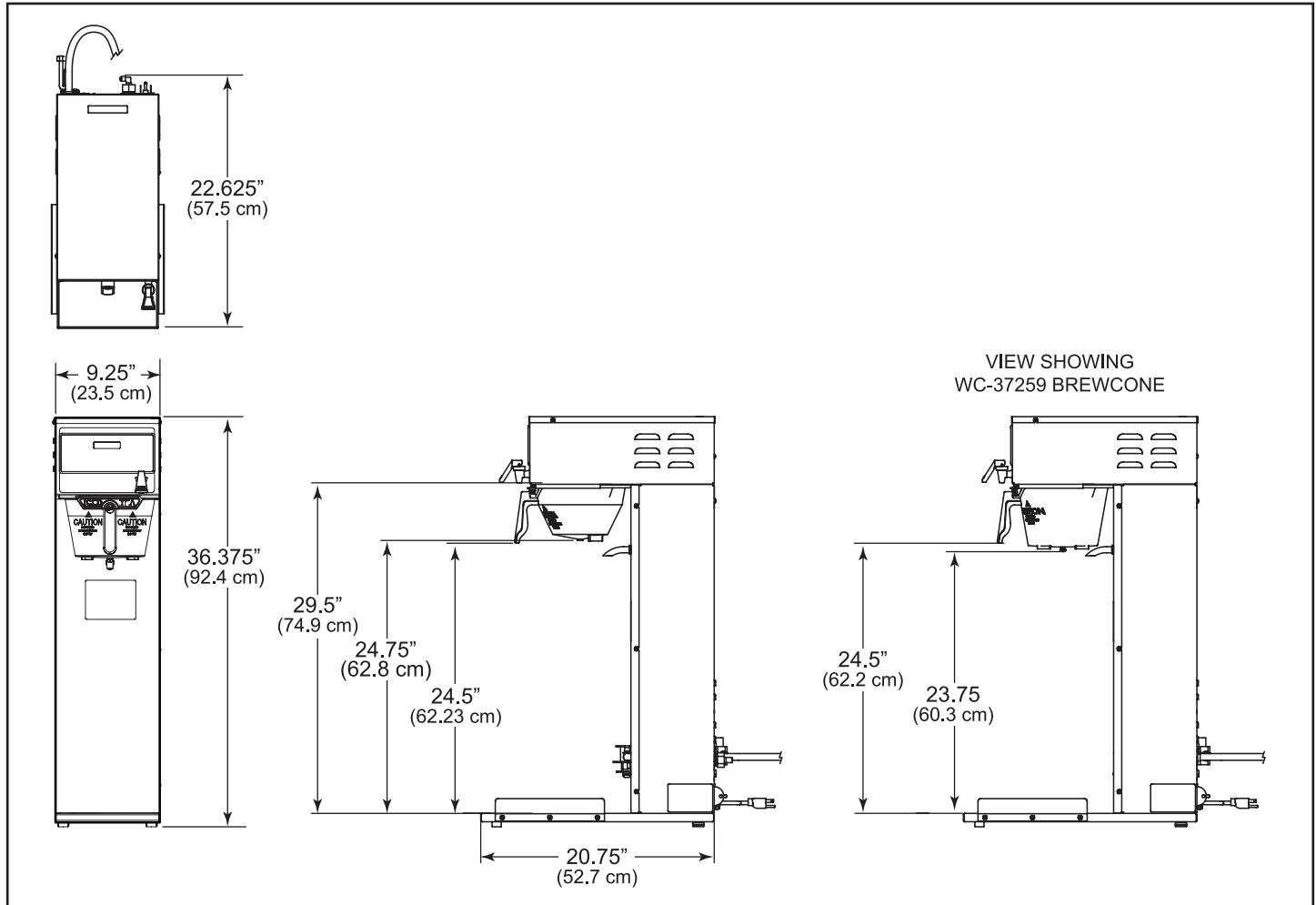

Cleaning The Brewer



IMPORTANT: Clean out the screen, within the brewcone, to maintain the flow of brewed tea. Neglecting this screen will eventually cause the brewcone to overflow, spilling hot liquid over the unit.



CAUTION: DO NOT use undiluted bleach or chlorine.



CAUTION: Never remove faucet when container is full. Drain container first.

DAILY

1. Wipe any spills, dust or debris from the exterior surfaces with a damp cloth. The outside surfaces of the brewer should be cleaned with stainless steel polish only, to prevent scratches.
2. Clean the sprayhead and domed area around the sprayhead with a mild detergent and warm water solution. Scrub well to remove residue. Rinse with and clear water. Dry with clean cloth.
3. Remove the plastic brewcone and wash with a detergent solution or put through a dishwasher.
4. Wash the beverage container.
 - A. Clean container and top cover with a detergent solution.
 - B. Remove the faucet assembly. Unscrew the handle assembly from the faucet and remove. Clean the faucet shank with a gauge glass brush (circular bristle) by pushing the brush through the shank.
 - C. Unscrew the bonnet assembly from the faucet. Brush clean the faucet body inlet and outlet. Clean the faucet cap and silicone seat cup. Dry and assemble parts.

Sweet Tea Mixing System Cleaning & Sanitizing

WEEKLY CLEANING & SANITIZING

Use a concentrated cleaning solution to simplify the cleaning procedure. This procedure requires a one gallon bucket of a cleaning solution of hot water (minimum 160°F) and a granulated concentrated cleaner (a cleaner like Coffee Dispenser Cleaner Corporation JavaClean3), diluted at 1.5 oz per gallon and a one gallon bucket of clean hot water (minimum 165°F).

1. Make sure brewer is on and water supply is hooked up.
2. Remove the quick disconnect from the tea sweetener bag-in-box product.
3. Pull the cap off of the QCD and place this end of the line into the container containing the cleaning solution (see illustration below).

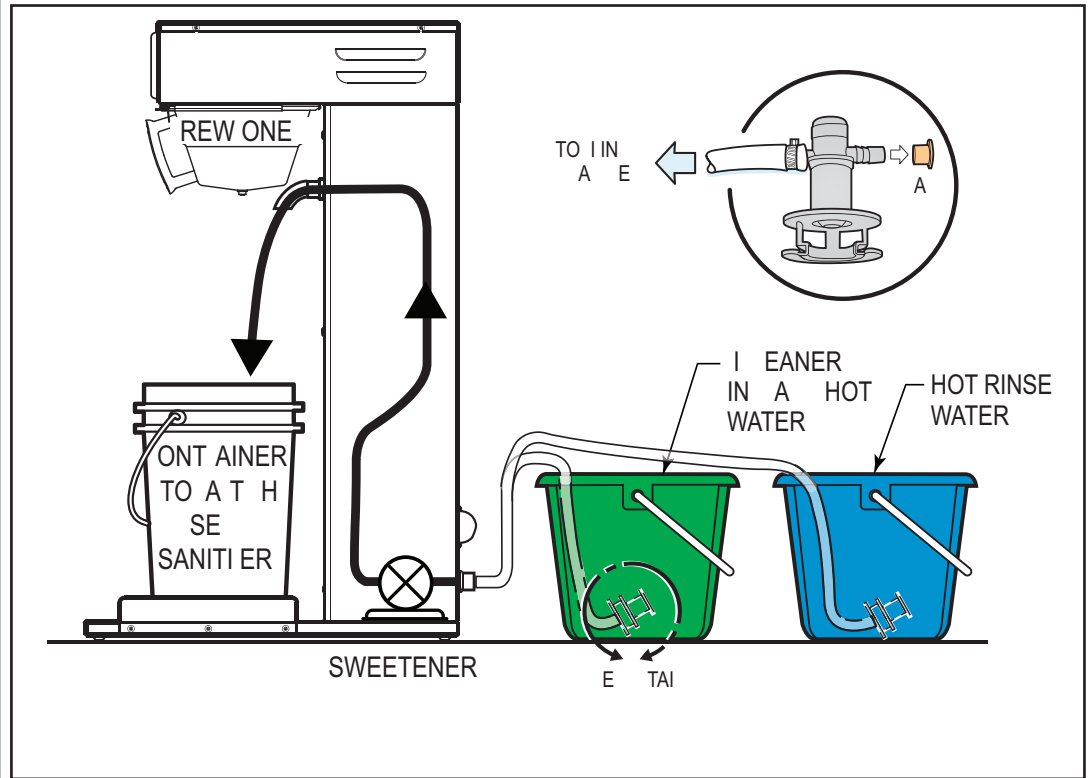

4. Place an empty tea container on the brew deck and an empty brewcone into the rails below the sprayhead.
5. Press the SWEET TEA brew button to run one complete brewcycle.
6. Allow the brewer to sit overnight with the cleaning solution in the sweetener line before flushing cleaning solution.
7. Flush the system by filling a one gallon container with clean hot water (no cleaning solution) and press the SWEET TEA brew button to run a brewcycle until all the cleaning solution has been flushed from the system.
8. Discard solution that poured into the container.
9. Remove the QCD from the flushing container and replace the cap. Reconnect the QCD to the Bag in the Box sweetener.
10. The unit is ready to resume brewing.

Sweetener Schematic Layout

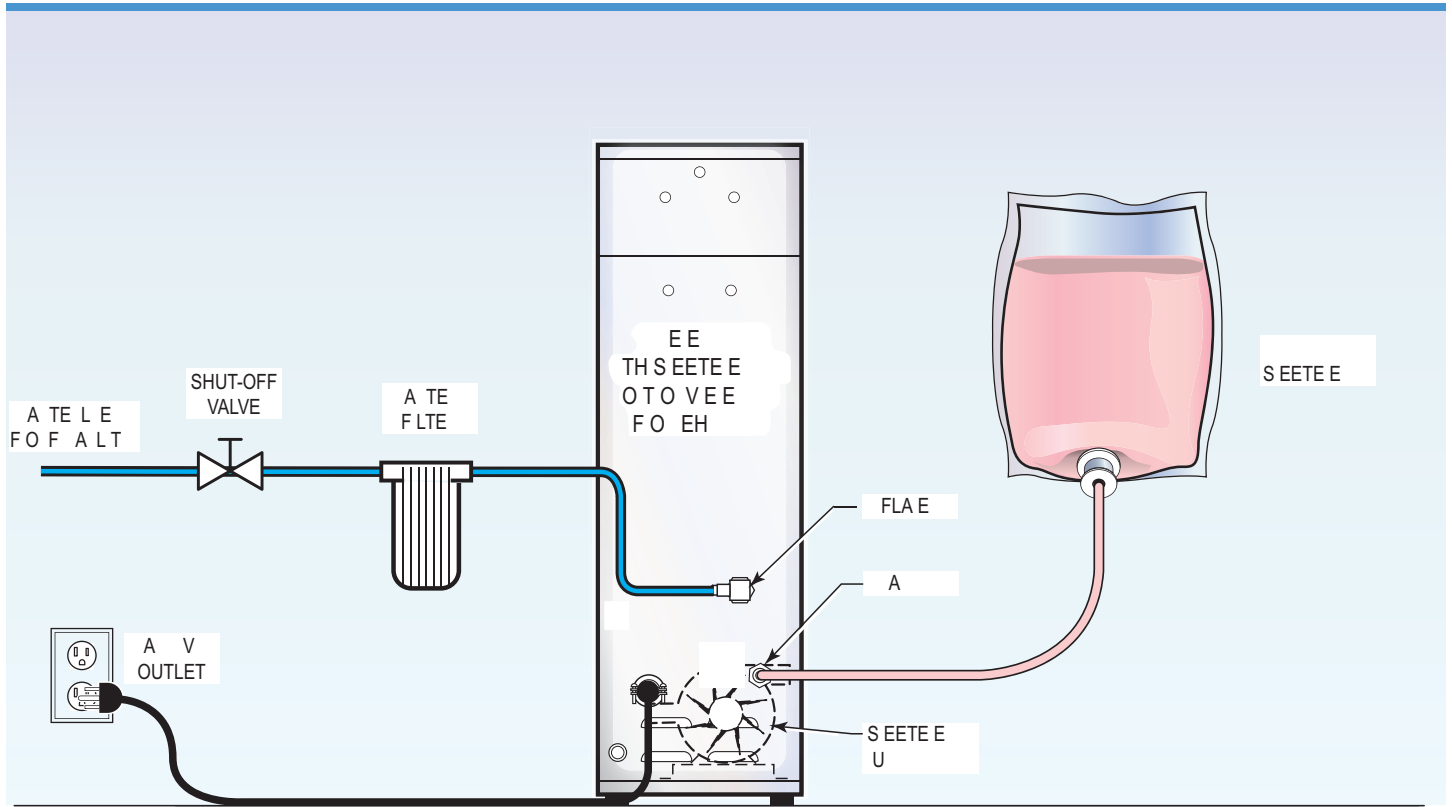

WARNING DO NOT refrigerate unused tea overnight for later consumption.

TEA TIPS

- Store tea bags in a dark, cool and dry place away from strong odors and moisture. Do not refrigerate.
- Do not hold brewed tea overnight.
- Make sure your equipment is clean at all times. Clean tea-brewing equipment at least once a day.
- Sanitize equipment at least once per week.
- Do not let fresh-brewed iced tea sit at room temperature for more than 8 hours.

As with other food products, if you adhere to proper preparation, holding and sanitation procedures, fresh-brewed iced tea is a safe beverage.

The primary cause for high bacteria counts found in tea from food service businesses is related to excessive holding times and/or poor cleaning and sanitizing procedures.

Page Intentionally Left Blank

Product Warranty Information

The Wilbur Curtis Company certifies that its products are free from defects in material and workmanship under normal use. The following limited warranties and conditions apply:

- 3 Years, Parts and Labor, from Original Date of Purchase on digital control boards.
- 2 Years, Parts, from Original Date of Purchase on all other electrical components, fittings and tubing.
- 1 Year, Labor, from Original Date of Purchase on all electrical components, fittings and tubing.

Additionally, the Wilbur Curtis Company warrants its Grinding Burrs for Forty (40) months from date of purchase or 40,000 pounds of coffee, whichever comes first. Stainless Steel components are warranted for two (2) years from date of purchase against leaking or pitting and replacement parts are warranted for ninety (90) days from date of purchase or for the remainder of the limited warranty period of the equipment in which the component is installed.

All in-warranty service calls must have prior authorization. For Authorization, call the Technical Support Department at 1-800-995-0417. Effective date of this policy is April 1, 2003.

Additional conditions may apply. Go to www.wilburcurtis.com to view the full product warranty information.

CONDITIONS & EXCEPTIONS

The warranty covers original equipment at time of purchase only. The Wilbur Curtis Company, Inc., assumes no responsibility for substitute replacement parts installed on Curtis equipment that have not been purchased from the Wilbur Curtis Company, Inc. The Wilbur Curtis Company will not accept any responsibility if the following conditions are not met. The warranty does not cover and is void under the following circumstances:

- 1) **Improper operation of equipment:** *The equipment must be used for its designed and intended purpose and function.*
- 2) **Improper installation of equipment:** *This equipment must be installed by a professional technician and must comply with all local electrical, mechanical and plumbing codes.*
- 3) **Improper voltage:** *Equipment must be installed at the voltage stated on the serial plate supplied with this equipment.*
- 4) **Improper water supply:** *This includes, but is not limited to, excessive or low water pressure, and inadequate or fluctuating water flow rate.*
- 5) **Adjustments and cleaning:** *The resetting of safety thermostats and circuit breakers, programming and temperature adjustments are the responsibility of the equipment owner. The owner is responsible for proper cleaning and regular maintenance of this equipment.*
- 6) **Damaged in transit:** *Equipment damaged in transit is the responsibility of the freight company and a claim should be made with the carrier.*
- 7) **Abuse or neglect (including failure to periodically clean or remove lime accumulations):** *Manufacturer is not responsible for variation in equipment operation due to excessive lime or local water conditions. The equipment must be maintained according to the manufacturer's recommendations.*
- 8) **Replacement of items subject to normal use and wear:** *This shall include, but is not limited to, light bulbs, shear disks, "O" rings, gaskets, silicone tube, canister assemblies, whipper chambers and plates, mixing bowls, agitation assemblies and whipper propellers.*
- 9) **Repairs and/or Replacements** *are subject to our decision that the workmanship or parts were faulty and the defects showed up under normal use. All labor shall be performed during regular working hours. Overtime charges are the responsibility of the owner. Charges incurred by delays, waiting time, or operating restrictions that hinder the service technician's ability to perform service is the responsibility of the owner of the equipment. This includes institutional and correctional facilities. The Wilbur Curtis Company will allow up to 100 miles, round trip, per in-warranty service call.*

RETURN MERCHANDISE AUTHORIZATION: *All claims under this warranty must be submitted to the Wilbur Curtis Company Technical Support Department prior to performing any repair work or return of this equipment to the factory. All returned equipment must be repackaged properly in the original carton. No units will be accepted if they are damaged in transit due to improper packaging. **NO UNITS OR PARTS WILL BE ACCEPTED WITHOUT A RETURN MERCHANDISE AUTHORIZATION (RMA). RMA NUMBER MUST BE MARKED ON THE CARTON OR SHIPPING LABEL.** All in-warranty service calls must be performed by an authorized service agent. Call the Wilbur Curtis Technical Support Department to find an agent near you.*



WILBUR CURTIS CO., INC.

6913 Acco St., Montebello, CA 90640-5403 USA

Phone: 800/421-6150 ♦ Fax: 323-837-2410

♦ Technical Support Phone: 800/995-0417 (M-F 5:30A - 4:00P PST)

♦ Web Site: www.wilburcurtis.com

✉-Mail: techsupport@wilburcurtis.com