



# Three Bowl Frozen Beverage Machine



## READ AND SAVE THESE INSTRUCTIONS

**NOTICE TO INSTALLER:** Please leave this booklet with the machine.

Key Features/Specifications/System Requirements..... FS98

Important Safeguards ..... IS10

Installation Instructions (General) .....II41

Installation Instructions (Layout, Electrical) .....II42

Operating Instructions .....OI60

Cleaning Instructions ..... CI31

Rough-In Drawing..... RD98

Illustrated Parts/Recommended Parts..... IP176

Electrical Schematics .....ES136

Troubleshooting Guide .....TG42

Error Codes .....EC13

Product Warranty.....PW2

**Contact Information**

**Wilbur Curtis Co., Inc.**

6913 Acco Street | Montebello, CA 90640 US  
Phone: 323-837-2300 | Toll Free: 800-421-6150  
Email: [cstrassistance@wilburcurtis.com](mailto:cstrassistance@wilburcurtis.com) | Web: [www.wilburcurtis.com](http://www.wilburcurtis.com)

For the latest specifications and information go to [www.wilburcurtis.com](http://www.wilburcurtis.com)  
Toll Free: 800-995-0417 | Monday - Friday 5:30 A.M. - 4:00 P.M. PT  
Email: [techsupport@wilburcurtis.com](mailto:techsupport@wilburcurtis.com)

Due to continued product improvement, the products illustrated/photographed in this guide may vary slightly from the actual product.

## Key Features

- Patented Ergonomically Designed Push & Pull Handles - Pull the top handle or push the bottom handle to easily dispense beverages.
- Large Capacity - 3.0 gallon bowls merchandise popular frozen beverages such as frozen cappuccino and frozen fruit flavors.
- Lighted Cover - With safety lock system.
- Standby Mode - Keeps product cool/refrigerated for overnight storage.
- Built-in Timer - Set to freeze product at specific time.
- Drip Tray Full Indicator - Prevents spills by warning when drip tray is full and needs to be emptied.
- Easy to Clean - No tools required.

## Specifications

### Electrical Supply Requirements

MODEL #	DESCRIPTION	PHASE	VOLTS	AMPS	MIN. CIRCUIT	WIRE	WATTS	HERTZ
CFB3	Three Bowl Frozen Beverage Machine	1 PH	115 V	14.8 A	20 A	2W + G	1800 W	50/60 Hz
CFB3A30	Three Bowl Frozen Beverage Machine Export, 50 Hz.	1 PH	230 V	9.0 A	12 A	2W + G	1200 W	50 Hz
CFB3A31	Three Bowl Frozen Beverage Machine Export, 60 Hz.	1 PH	230 V	9.0 A	12 A	2W + G	1200 W	60 Hz

### Dimensions - Weight

### Operating Temperature

MODEL #	HEIGHT	WIDTH	DEPTH	CUP CLEARANCE	BOWL CAPACITY	SHIP CUBE	SHIP WEIGHT	MINIMUM	MAXIMUM
CFB3 CFB3A30 CFB3A31	35.51"	24.53"	19.57"	11.75"	3 gal (12 lit.) each	14.20 cu ft	165.0 lbs	68°F/20°C	90°F/30°C

### Refrigerant\*

MODEL #	TYPE	AMOUNT	HIGH DESIGN PRESSURE	LOW DESIGN PRESSURE
CFB3 CFB3A30 CFB3A31	R404A	16.68 ounces	397 psig	175 psig

\* For reference only. Check the serial number label on the product for the refrigerant specifications for the unit being serviced.

**Symbols**



This is the safety alert symbol. It is used to alert you to potential physical injury hazards. Obey all safety messages that follow this symbol to avoid possible injury or death.



**DANGER** - Indicates a hazardous situation which, if not avoided, will result in death or serious injury.



**WARNING** - Indicates a hazardous situation which, if not avoided, could result in death or serious injury.



**CAUTION** - Indicates a hazardous situation which, if not avoided, could result in minor or moderate injury.



**NOTICE** - Indicates a situation which, if not avoided, could result in property damage.



**IMPORTANT** - Provides information and tips for proper operation.



**SANITATION REQUIREMENTS**



**WARNING** - This product can expose you to chemicals including Acrylamide and Bisphenol A (BPA), which are known to the State of California to cause cancer and birth defects or other reproductive harm. For more information visit [www.P65Warnings.ca.gov](http://www.P65Warnings.ca.gov).

**Important Safeguards/Conventions**







**WARNING:**

- Make sure that this appliance is installed and grounded according to the INSTALLATION INSTRUCTIONS by qualified personnel before attempting to use it. Failure to follow the INSTALLATION INSTRUCTIONS could result in personal injury or void the warranty.
- This appliance is designed for commercial use. Any service other than cleaning and preventive maintenance should be performed by an authorized Wilbur Curtis service technician.
- To reduce the risk of fire or electric shock, DO NOT open the service panels. There are no user serviceable parts inside.
- Do not put hands, arms and other items inside the mixing bowl when the main power switch is ON (I). Keep the mixing switch in the OFF (O) position, whenever the lid is removed.
- Clean the appliance completely before using it for the first time according to the CLEANING INSTRUCTIONS. Perform cleaning and preventive maintenance regularly as specified in the CLEANING INSTRUCTIONS section.
- Use this appliance only for its intended use, preparing and dispensing frozen beverages.
- This appliance is not intended for use by persons (including children) with reduced physical, sensory or mental capabilities or lack of experience and knowledge, unless they have been given supervision or instruction concerning use of the appliance by a person responsible for their safety. Children should be supervised to ensure that they do not play with the appliance.
- Avoid spillage onto the power (mains) connector.

## CE Requirements

- This appliance must be installed in locations where it can be overseen by trained personnel.
- For proper operation, this appliance must be installed where the temperature is between 20°C to 32°C (68°F to 90°F).
- Appliance shall not be tilted more than 10° for safe operation.
- An electrician must provide electrical service as specified in conformance with all local and national codes. For safe use, an all-pole disconnection must be incorporated into the fixed wiring in accordance with the wiring rules outlined in clause 7.12.2 of IEC 6.335-1 for meeting the minimum electrical safety of this standard.
- This appliance must not be cleaned by water jet.
- This appliance can be used by persons aged from 18 years and above if they have been given supervision or instruction concerning use of the appliance in a safe way and if they understand the hazards involved.
- Keep the appliance and its cord out of reach of children aged less than 18 years.
- Appliances can be used by persons 18 years and above with reduced physical, sensory or mental capabilities or lack of experience and knowledge if they have been given supervision or instruction concerning use of the appliance in a safe way and understand the hazards involved.
- Children under the age of 18 years should be supervised to ensure they do not play with the appliance.
- If the power cord is ever damaged, it must be replaced by the manufacturer or authorized service personnel with a special cord available from the manufacturer or its authorized service personnel in order to avoid a hazard.
- Machine must not be immersed for cleaning.
- Cleaning and user maintenance shall not be made by children unless they are older than 18 years and supervised.
- This appliance is intended to be used in household and similar applications such as:
  - staff kitchen areas in shops, offices and other working environments;
  - by clients in hotels, motels and other residential type environments;
  - bed and breakfast type environments.
- This appliance not intended to be used in applications such as:
  - farm houses
- Access to the service areas permitted by Authorized Service personnel only.
- The A-Weighted sound pressure level is below 70 dBA.

-  **WARNING:** Installation is to be performed only by a qualified installer.
-  **WARNING:** Improper electrical connection may result in an electric shock hazard. This unit must be properly grounded. Do not install a damaged unit or a unit with a damaged power cord.
-  **EXCESSIVE WEIGHT WARNING:** Due to weight, this unit requires a minimum of two people to lift or reposition.
-  **NOTICE:** Dispose of refrigeration equipment and refrigerants in accordance with current local environmental protection regulations and laws. This applies to an appliance that is being replaced and to this unit, when it has reached the end of its service life. DO NOT dispose of refrigeration equipment in a landfill or urban waste. Contact your local governing authorities for information on disposal requirements.
-  **IMPORTANT:** Observe all governing codes and ordinances.

## Installation Instructions

### Installation Requirements

- Install on a secure surface capable of supporting the weight of the appliance (see **SPECIFICATIONS** section). The unit must be installed indoors away from sources of moisture and heat. The clearances shown below are the minimum distances from obstructions, from other equipment and between units, when more than one unit is installed. These are the minimum distances required for proper operation. Do not obstruct the ventilation grills on the back and sides.
- Locate the unit on a secure, level surface. Install it so that it can be easily removed if service is needed.
- A grounded electrical connection to an electrical circuit that meets the electrical specifications of the appliance (see **SPECIFICATIONS**). The circuit must be protected by the appropriate sized circuit breaker. If you are not certain that the existing circuit meets the requirements for your unit, consult a licensed electrician.
- The electrical outlet must be in a location that allows the unit to be easily disconnected for service or cleaning.

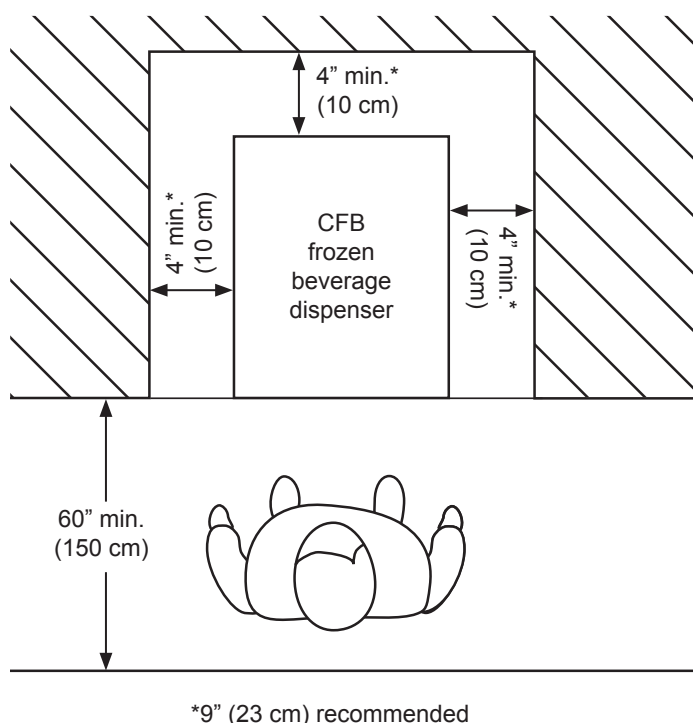

### Installation

#### Unpack the unit

- 1 When unpacking the unit, keep the original packaging materials in the event the unit needs to be returned to the manufacturer.

**i IMPORTANT:** RMAs will not be accepted unless the unit is packaged in the original packaging material.

#### Leveling

- 2 Locate the legs, packaged inside the bowls. Thread them into the mounts on the bottom of the unit. Hand tighten into place.

**! WARNING:** Use the leveling legs to level the machine only. Do not use them to adjust the height of the unit. Do not extend them higher than necessary.

- 3 Position the machine on the counter top. Level it left to right and front to back by turning the bottom of the legs.

#### Attach Drip Trays and Handles

- 4 Locate the drip trays, packaged inside the bowls.
- 5 Position the drain hose in the opening in the top of each tray. Then, insert the tabs on the back of the drip tray into the holes on the front of the chassis. Push down gently to secure in place.

- 6 Prepare to install the dispensing levers by removing the handles from the taps. Push in on the top of the handle with your thumb while pulling up on the bottom with your index finger.

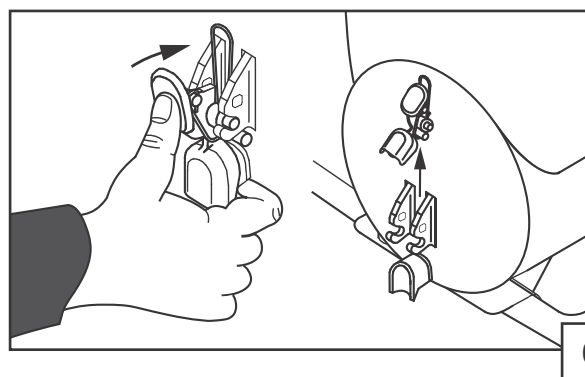
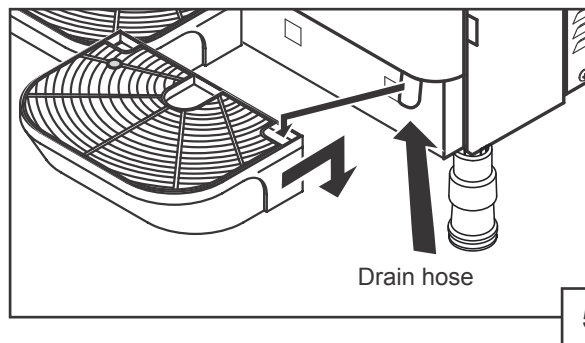
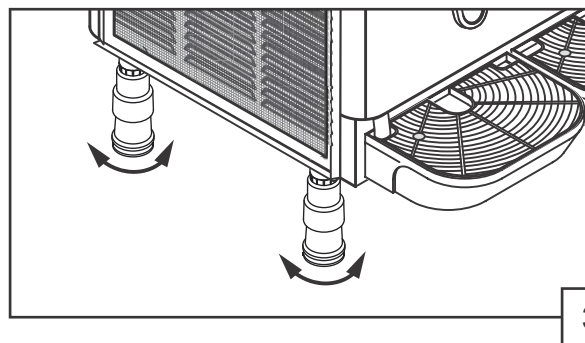
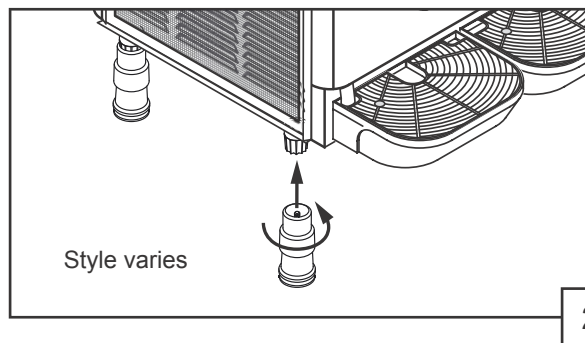

**Attach Drip Trays and Handles (cont.)**

- 7 Locate the dispensing levers, packaged inside the bowls. Install them on the tap handles. While pulling outward on both sides of the base of the dispensing lever, insert the pins on the bottom of the handle into the base holes on the lever.



- 8 Lubricate the tap mounting slots using food grade lubricant.
- 9 Prepare the tap handle assembly for attachment. Lubricate the red rubber seal on the back of the tap handle assembly with food grade lubricant (1 tube included). Insert the seal into the tap hole on the bottom of the bowl. Line up the spring and the middle pins on the handle, as shown. **NOTE:** Later versions of the mixing bowl have a hook to help line up the spring.

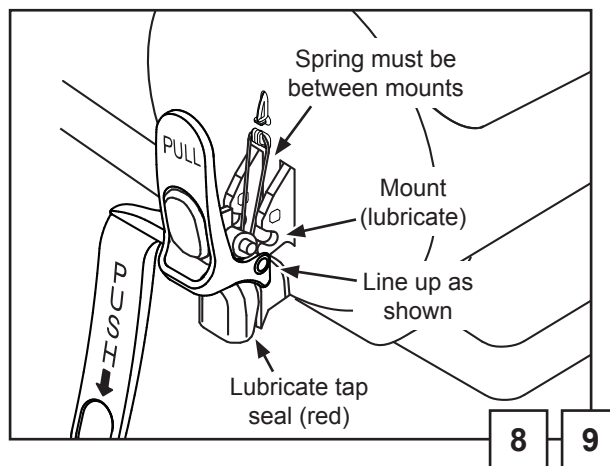

- 10 Attach the tap handle assembly. Push in with your thumb on the center of the handle until the tap handle assembly pops into place.

continued...

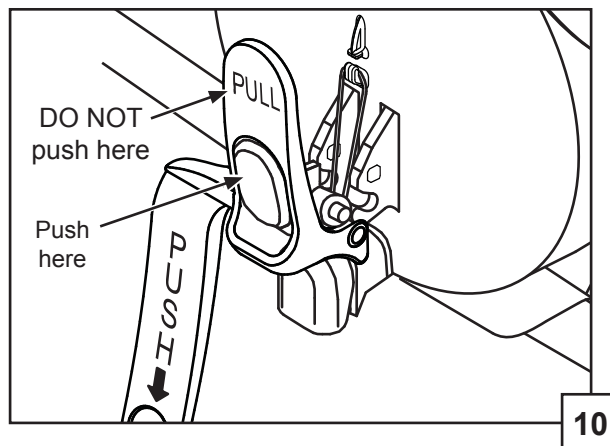

**Set the Timer Clock for Initial Operation (some models)**



**NOTICE:**

- Set the timer only with the main power switch in the OFF (O) position.
- Turn the timer wheel only by hand and only in the clockwise direction.



**IMPORTANT:** The unit may not operate as desired if the timer clock is not set properly.

- 11 With the main power switch off, turn the outer wheel on the timer clockwise until the correct time (AM or PM) lines up with the arrow on the clock face.
- 12 Check to make sure that all of the timer tabs are rotated to the “freeze” position (see diagram).

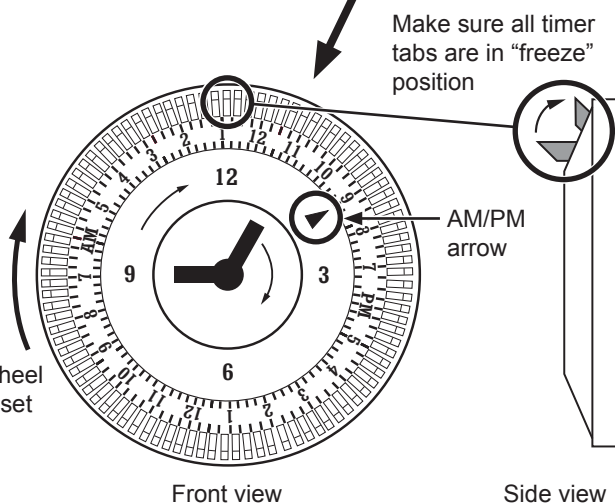
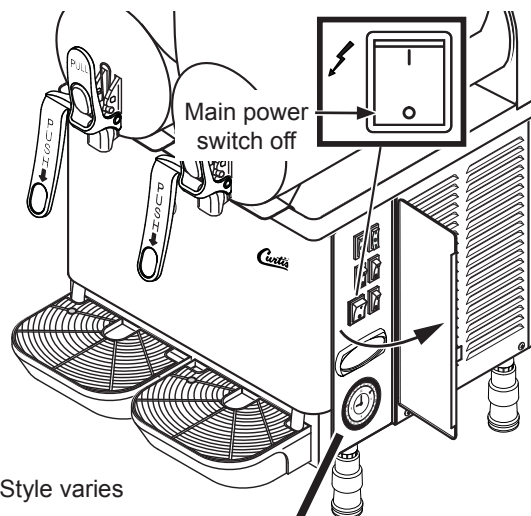

**Power Up the Unit**



**WARNING:** Connect the power cord to the appropriate type and size electrical outlet. If the electrical outlet is not compatible with the power cord, have it upgraded by a licensed electrician. Do not modify the power plug. Do not use an extension cord.

- 13 Connect the power cord to the appropriate type of electrical outlet.
- 14 Make sure that the circuit breaker supplying power to the unit is on.
- 15 Turn ON (I) the main power switch.
- 16 Clean and sanitize the unit before using it for the first time as instructed in the **CLEANING INSTRUCTIONS** section. Verify that the unit is operating properly according to the **OPERATING INSTRUCTIONS** section.

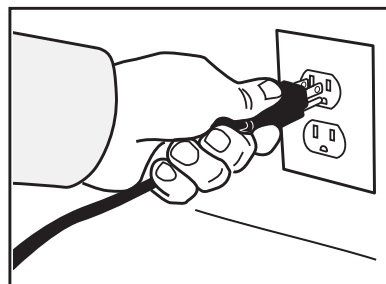

**WARNING** - Do not use this unit with milk/dairy based mixes unless it is equipped with a temperature display. Do not leave milk/dairy based mixtures in the unit without the main power switch on and the refrigeration switch set to standby (||) or freeze (I).



**WARNING** - If the tank is filled with a milk or dairy based mix, dispense a small amount of the product from the tap into a separate container before dispensing the serving for the customer.

**NOTICE**

- Use only slush mixtures with the required sugar content.\* Do not freeze water alone.
- Never pour hot liquids (above 77°F/25°C) into the mixing bowl.
- Do not fill the mixing bowl higher than the MAX LEVEL indicator.

**Freezing Instructions**

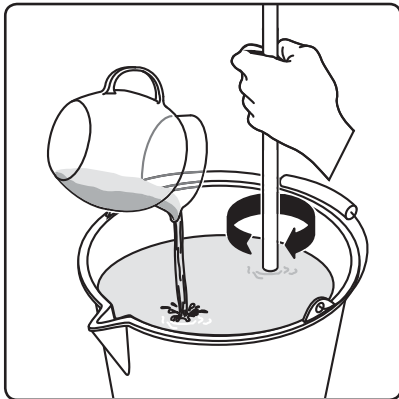

1. For slush type frozen beverages, mix slush concentrate with water in a clean container, according to manufacturer's directions.\* Each mixing bowl has a 3 gallon (12 liter) capacity. For milk/dairy based mixes, use according to instructions on package.

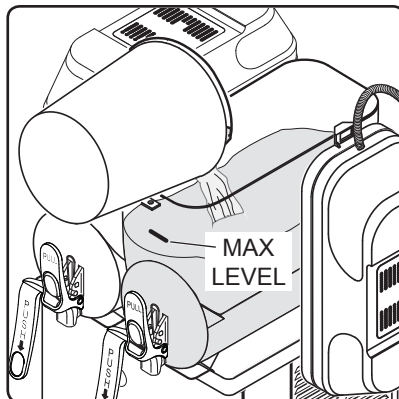

2. With mixing switch in OFF (O) position, remove mixing bowl lid and hang it on side. Pour in mix up to, or below MAX LEVEL indicator. Minimum level is just above plastic mixing auger.

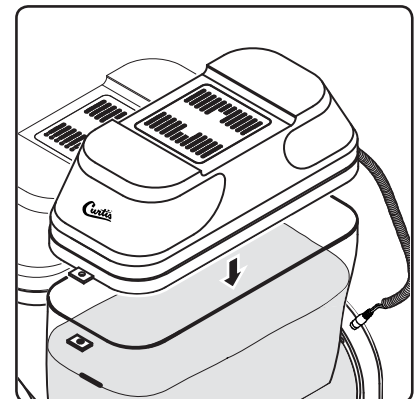

3. Replace mixing bowl lid.

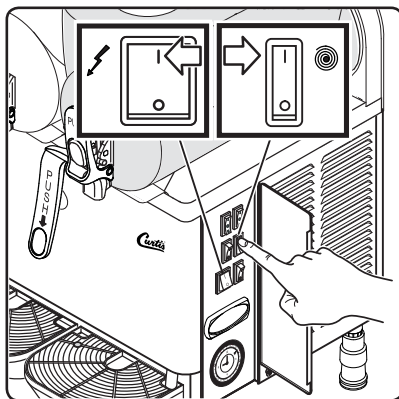

4. Make sure that main power switch is ON (I). Push (I) on mixing switch for desired mixing bowl to turn on mixer. **NOTE:** When the main power switch is turned on, it may take up to 5 minutes for all internal system components to initialize.

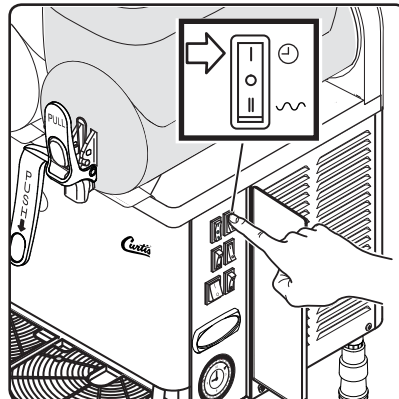

5. Push (I) on refrigeration switch for desired mixing bowl to begin freezing. Standby mode, position (||) on refrigeration switch, saves energy, keeping mixture cool without freezing. **NOTE:** On units equipped with a timer, see **Timer Operation** for timer instructions.

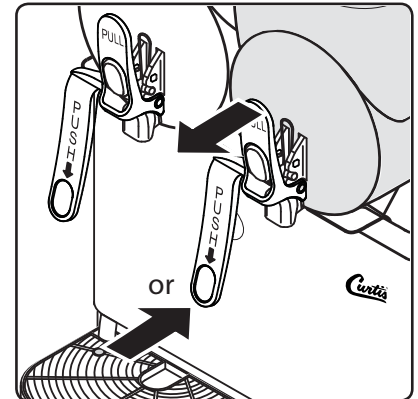

6. Once mixture is frozen (40 to 90 minutes), pull out on top of dispenser lever or push bottom of lever to dispense.

\* The mixture obtained MUST have a sugar content between 13°Bx and 22°Bx (11 to 20% sugar by weight).

### Bowl Lights

Push (I) on the light switch to turn on the integral lid lights.

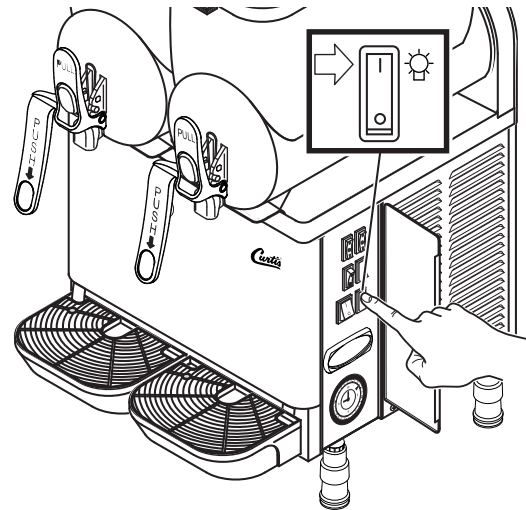

### Adjusting Beverage Thickness

Use the adjustment screws at the back of each mixing bowl to adjust beverage thickness. The recommended (factory default) setting is 2. Insert a flat blade screwdriver into the adjustment hole as shown and turn to adjust. The indicator on the back will move to indicate the thickness level. The higher the number, the thicker the frozen beverage consistency.

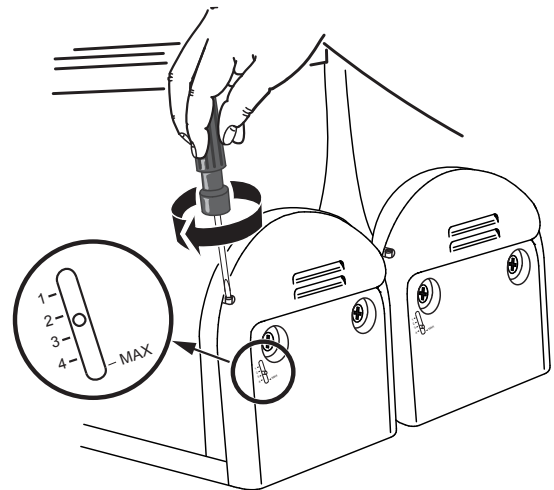

**i IMPORTANT:** When the thickness level is set to higher levels, (around 4) the lid should be fastened to prevent it from coming off during operation.

### How to Read the Digital Temperature Display (some models)

The temperature display indicates the temperature in the mixing bowls. The display changes every three seconds to show the temperature in a different bowl. The dot at the bottom of the display indicates the bowl temperature that is currently being displayed. See the diagrams below for more information. The bowls are numbered 1, 2 and 3\*, left to right, when facing the front of the unit.

**i NOTE:** If the display shuts off, it can be reset by pushing the down arrow button (▼).

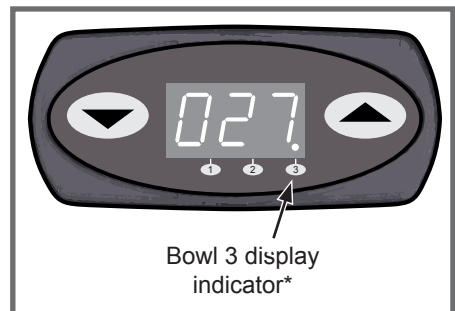
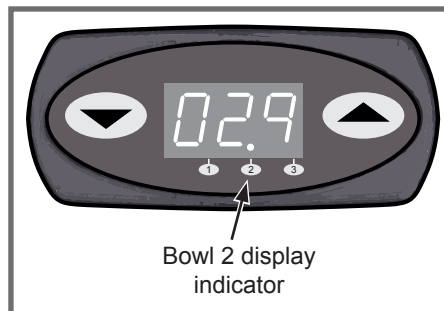
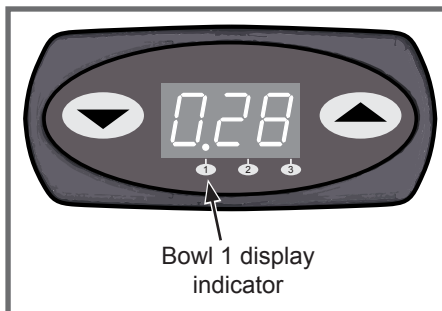

\* CFB3 only

### Setting the Timer Clock (some models)



**NOTICE**

- Set the timer only with the main power switch in the OFF (O) position.
- Turn the timer wheel only by hand and only in the clockwise direction.

- 1 With the main power switch off, turn the outer wheel on the timer clockwise until the correct time (AM or PM) lines up with the arrow on the clock face (Figure 1).
- 2 Turn on the main power switch to start the clock.



**IMPORTANT:** The clock/timer is equipped with a backup circuit and continues to keep time for 10 to 15 minutes after power is interrupted. If the power cord is disconnected or the main power switch is turned off for a longer period of time, the clock will need to be reset when power is restored.

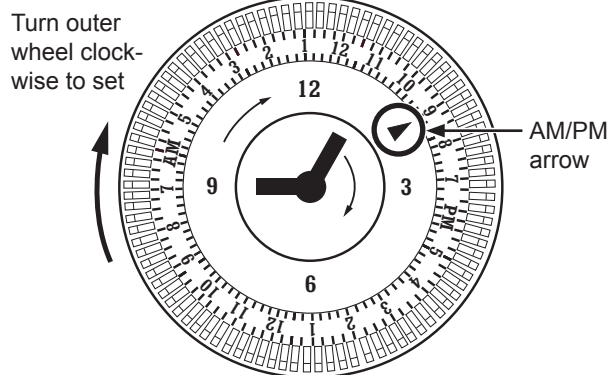
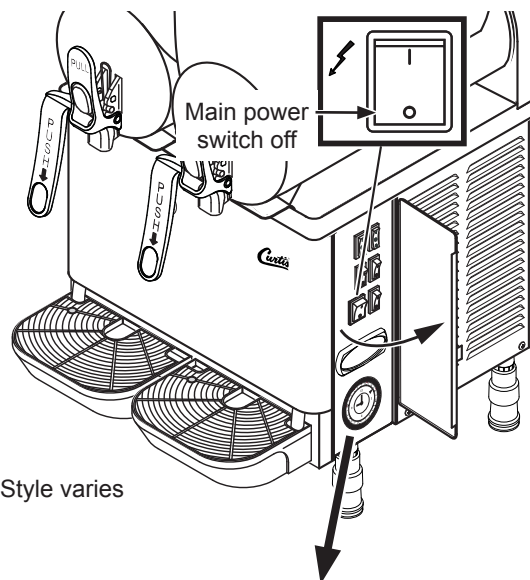

Figure 1

### Timer Operation (some models)

Use the timer to start the unit automatically. This feature allows you to pour the mix in ahead of time and have the frozen beverage ready to serve at the programmed time (unattended operation). The timer determines when the unit is in standby (night) mode or freeze mode. In standby mode the mixture is kept cool, but does not freeze.

The unit comes from the factory set for manual (non-timer) operation. When all of the timer tabs are flipped outward (see diagram, right), the timer is disabled and the unit will freeze the mixture any time the refrigeration switch is set to ON (I).

### Setting Up the Timer

- 1 With the main power switch off, flip the timer tabs next to the time marks on the timer to either the standby or freeze position (Figure 2). The unit will operate in the mode selected during the corresponding time period.
- 2 Check to make sure the clock is set to the current time, then turn ON (I) the main power switch.

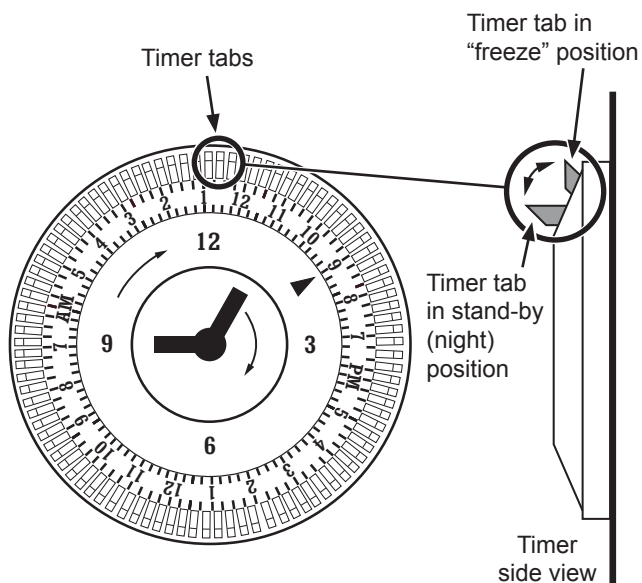

Figure 2



- WARNING**
- Turn off the main power switch before disassembly. Wear protective glasses and gloves.
  - Never spray water on the unit to clean it. Do not use cleaning liquids, compounds or powders containing chlorine (bleach), solvents, scouring powder, flammable materials or corrosives. These products promote corrosion and will damage the surfaces. USE OF THESE PRODUCTS WILL VOID THE WARRANTY.
  - DO NOT immerse the unit or parts in water or any other liquid, unless specifically instructed to do so. Do not wash any of the components in a dishwasher. Hand or air dry the parts only.

**Daily Cleaning**

Clean and sanitize all of the bowl assemblies at least once a day according to the following steps. These operations may need to be performed more frequently based on the mix used. Contact the concentrate/mix supplier for more details. If the machine is not used continuously throughout the day, wipe the tap areas with a clean cloth and sanitizing fluid. If the dispenser has not been used for a long period of time, clean the unit before returning it to use.

- 1 For cleaning, prepare a mild solution of detergent and warm water.

**Empty the Drip Tray**

- 2 Drain the drip trays every time the red full indicator pops up.
- 3 Empty and clean the drip trays every day. Remove them by lifting them up and out.
- 4 Wash the trays and grills with the detergent solution. Hand dry all of the pieces, then reinstall the grills. Set the drip trays aside.

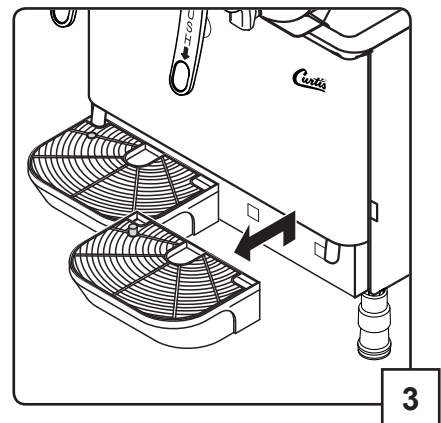
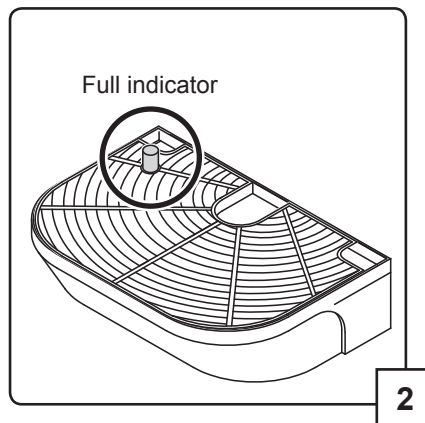

**Empty the Bowls**

Skip to step 8 if the bowls are empty.

- 5 Place a large empty container under each dispenser tap.
- 6 Turn the main power switch to the ON position. Turn the mixing switches to the ON (I) and the refrigeration switches to the OFF (O) position. Pull out on each dispenser lever to drain the contents out of each bowl. If the mixture is not frozen, hold the container up to the tap to reduce splashing.
- 7 Once the bowls are empty, turn the main power switch to the OFF (O) position.

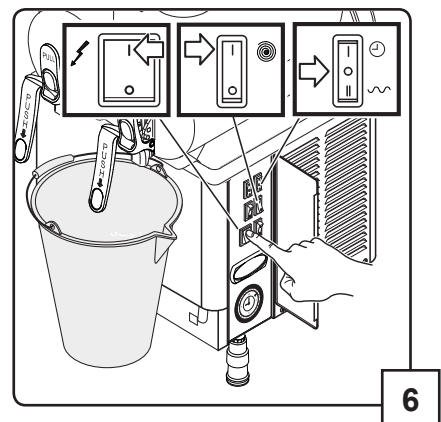
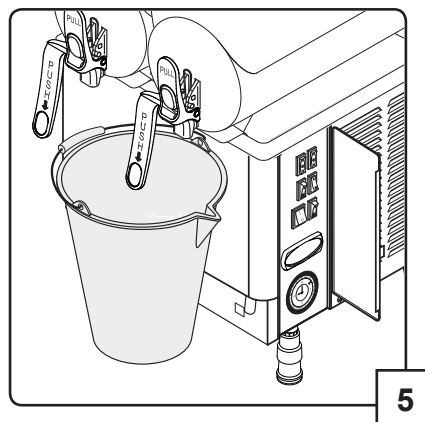

continued...

**Daily Cleaning (cont.)**

**Remove the Mixing Bowls and Lids**

- 8 Remove the handle assemblies from the bowl taps by pushing in on the top of the handle with your thumb while pulling up on the bottom with your index finger.
- 9 Disconnect the light plugs from the sockets behind the mixing bowls. Do not allow the plugs to come into contact with liquids while removed.

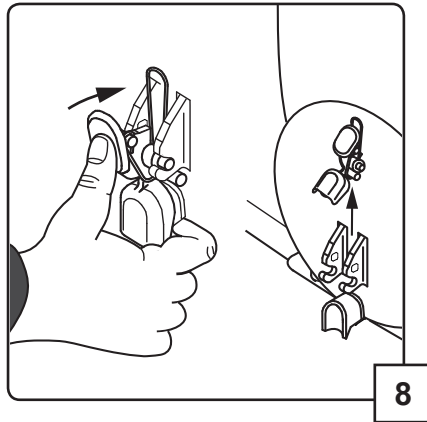

- 10 Lift off the lids. Raise the front part of each bowl to release. Remove each bowl from its seat by pushing and tapping lightly on the rear.
- 11 Pull the bottom part of the lids free from the top part.

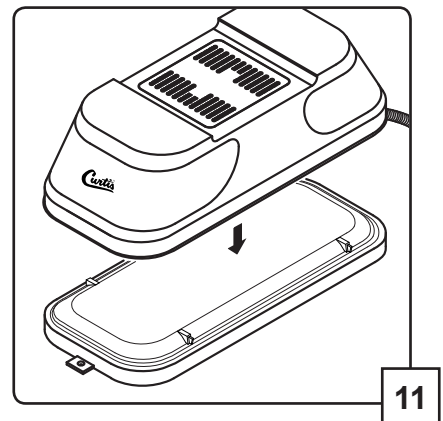
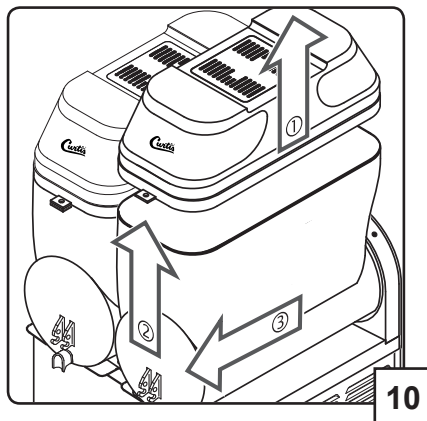

**NOTICE:** To prevent damage, DO NOT immerse the top portion of the lid in fluids of any kind.

- 12 Pull forward on each auger to remove it from the drum. Remove the auger seal.
- 13 Remove the bowl seals.

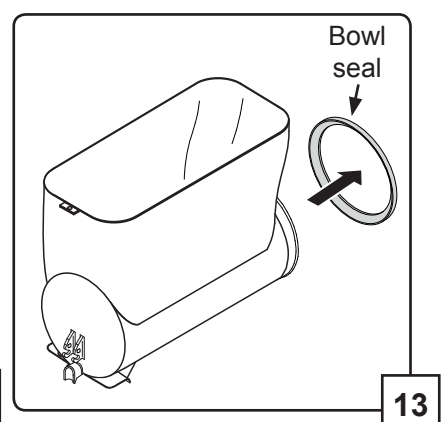
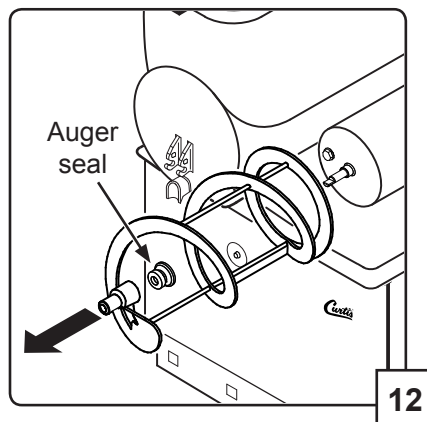

- 14 Inspect all auger, bowl and tap seals. Replace all worn or damaged seals with new ones. Replace the auger seals (Curtis PN WC-100196K) every 3 months, regardless of condition.



**NOTICE:** Failure to replace worn seals may result in leaks.

**Clean the Mixing Bowl Parts**

- 15 Soak the bottom part of the lids, removed in step 11, the tap parts and auger in the detergent solution and scrub with a soft cloth. Rinse in fresh water.
- 16 To clean the top portions (lighted part) of the lids, use a clean, damp cloth soaked with detergent solution. Using a clean, damp cloth, wipe clean the outside portion of the lid top. Wipe with a clean, damp cloth soaked in fresh water.
- 17 Clean the mixing bowls and drums with a clean damp cloth soaked with detergent solution. Wipe with a clean, damp cloth soaked in fresh water.

continued...

**Daily Cleaning (cont.)**

**Sanitizing**

- 18 Fill a container with a sanitizer solution mixed in water (2% of sodium hypochlorite mixed in water).
- 19 Using a sponge dipped in sanitizing solution, sanitize the underside of the bottom portion of the lids. Allow 30 minutes for the solution to act.
- 20 Rinse the underside of the lid bottoms with a clean sponge soaked in fresh water. Place the lids on a clean surface and hand dry, first the underside, then the outside, using a clean cloth.
- 21 Thoroughly wash the bowl and drum with a sponge soaked in the sanitizer solution. Rinse thoroughly with clean water.
- 22 Fill another container with sanitizer solution and submerge the tap parts, augers and seals in the sanitizer solution. Leave them to soak in the solution for 30 minutes. Rinse thoroughly with clean water, then air dry.

**Reassemble the Unit**

- 23 Install each auger seal on each auger.

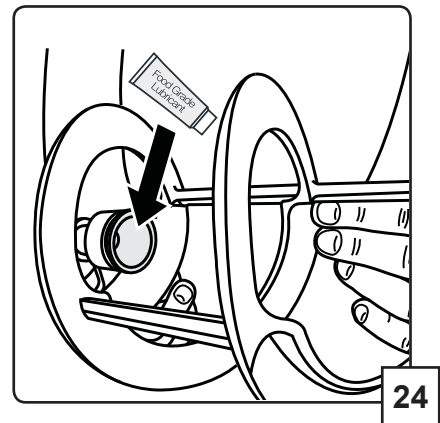
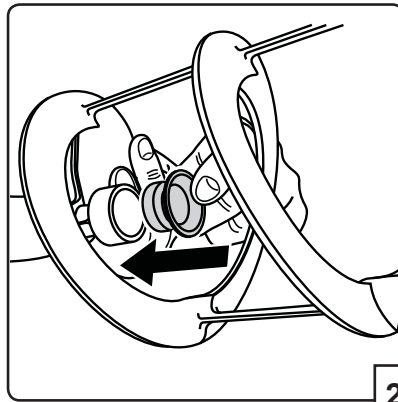

**NOTICE:** Failure to lubricate seals may result in leaks.

- 24 Using food grade lubricant (Curtis PN [WC-4916](#)), lubricate the inside of the auger seal.

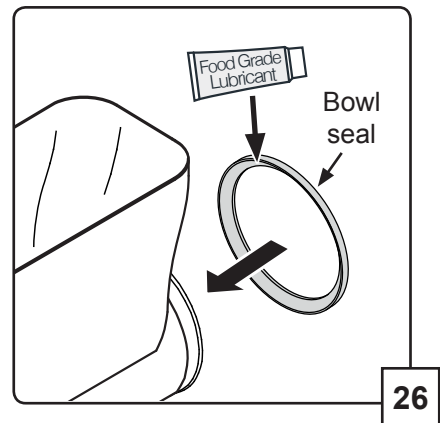
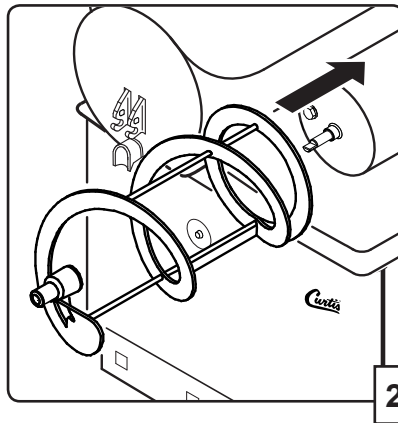

- 25 Reinstall the augers. Rotate each auger until it engages completely.
- 26 Lubricate the inner surface on each bowl seal with food grade lubricant. Install a bowl seal on the back of each bowl.

- 27 Set the mixing bowls back in place. Make sure that the lip on the bottom of each bowl rests inside the front trim on the top of the chassis.

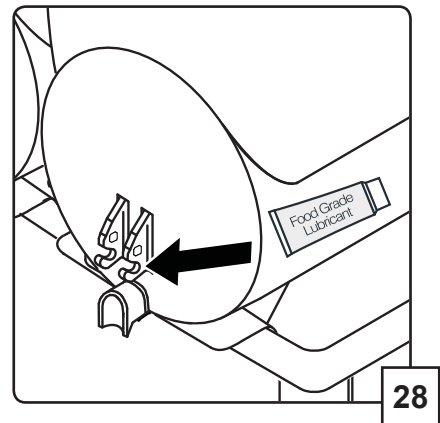
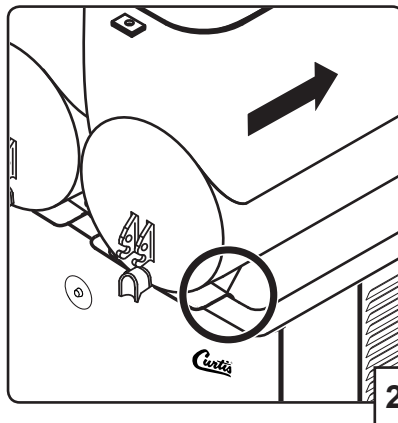

- 28 Lubricate the tap mounting slots on the front of each mixing bowl with food grade lubricant.

continued...

**Cleaning - Reassemble the Unit (cont.)**

29 Prepare the tap handle assembly for attachment. Lubricate the red rubber seal on the back of the tap handle assembly with food grade lubricant (Curtis PN [WC-4916](#)). Insert the seal into the tap hole on the bottom of the bowl. Line up the spring and the middle pins on the handle, as shown. **NOTE:** Later versions of the mixing bowl have a hook to help line up the spring.

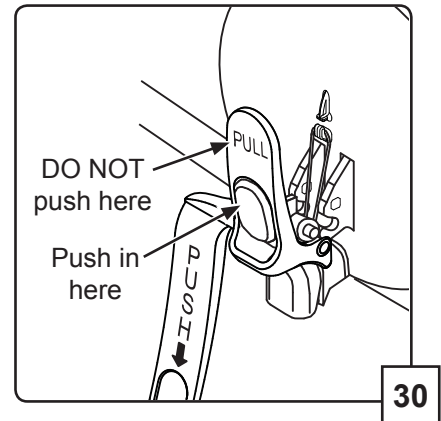
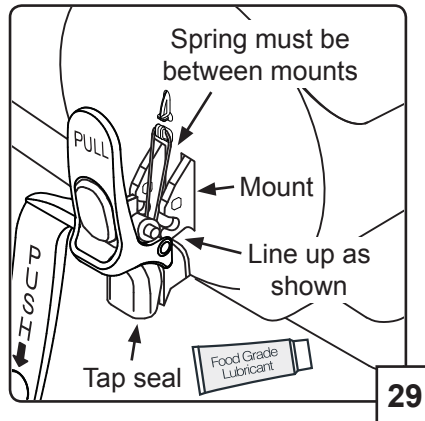

30 Attach the tap handle assembly. Push in with your thumb on the center of the handle until the handle assembly pops into place.

31 Reassemble and reinstall each lid and insert the light plug into the socket behind each bowl.

Before starting up the unit again after cleaning, rinse it out as follows:

32 Fill the mixing bowls with clean water.

33 Turn the main power switch to the ON (I) position. Push (I) on the mixing switches for all of the mixing bowls. Make sure the refrigeration switches are OFF (O).

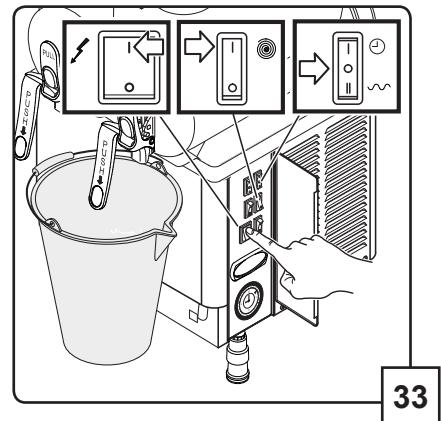
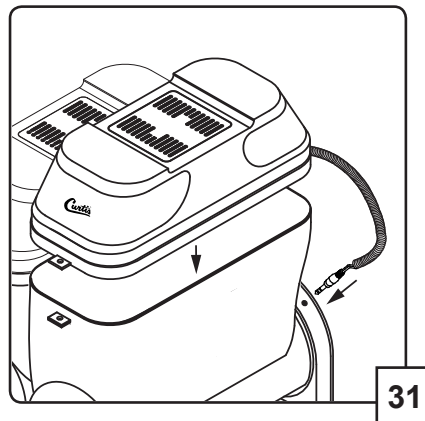

34 Leave the unit on for five minutes.

35 Drain the water from each of the mixing bowls by placing a container under the tap and pulling the lever.

**Reinstall the Drip Trays and Wipe Up**

36 Position the drain hose in the opening in the top of each tray. Then, insert the tabs on the back of the drip tray into the holes on the front of the chassis. Push down gently to secure in place.

37 Wipe any dust or debris from the exterior surfaces of the unit with a damp cloth. Wipe up any spills/liquids in the surrounding area.

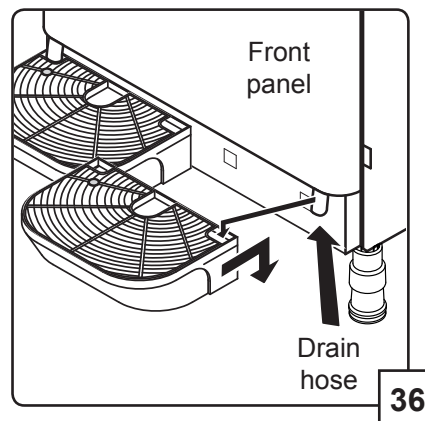

**Clean the Filter (Weekly)**

- 1 Make sure the main power switch is in the OFF (O) position.
- 2 Lift the filter up and out of the slot on the left side of the unit.\*
- 3 Clean the ventilation louvers on the outside of the unit and the filter with a vacuum or soft bristled brush.
- 4 Reinstall the filter.

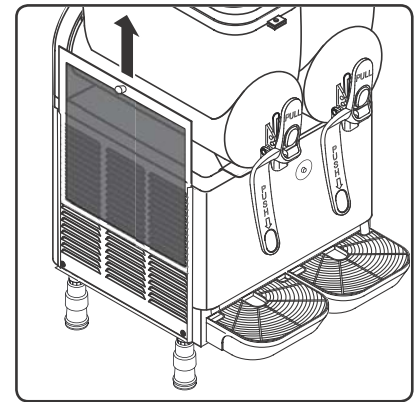

\* For units equipped with a filter

**Preventive Maintenance - (Perform Every 6 Months)**



- WARNING**
- The following procedure is to be performed only by a qualified service technician.
  - Failure to perform preventive maintenance as required, may result in leaks and/or damage to the unit. Damage resulting from failure to perform required maintenance and/or leaks is not covered by the warranty.
  - Turn off the main power switch before disassembly.

**Seal and Bushing Replacement**

WC-100196K - Auger seal<sup>1</sup>

WC-100195K - Drum bushing

WC-100010 - Tap seal

WC-100253 - Bowl seal

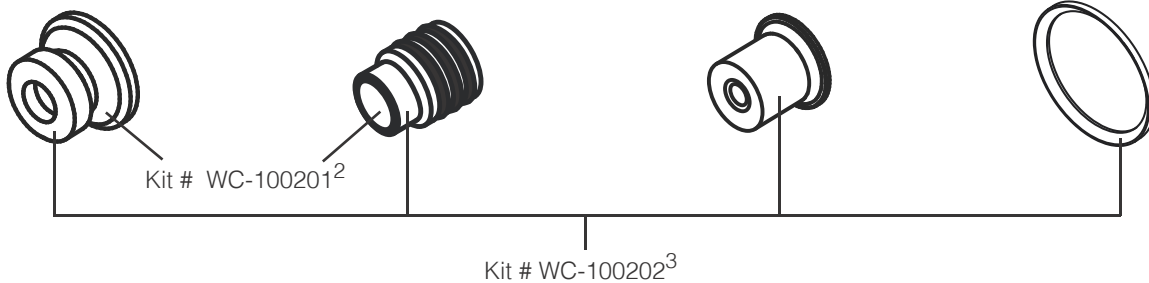

<sup>1</sup> Replace every 3 months, or as needed.

<sup>2</sup> Replace every 6 months, or as needed. Use kit # WC-100201 (2 sets per kit).

<sup>3</sup> Replace once a year, or as needed. Use kit # WC-100202 (2 sets per kit).

Also required: Curtis Part # WC-4916, food grade lubricant (sold separately)

**Empty the Bowls** (Skip to step 3 if the bowls are already empty)

- 1 Place a large empty container under each dispenser tap. Turn the main power switch to the ON position. Turn the mixing switches to the ON (I) and the refrigeration switches to the OFF (O) position. Pull out on each dispenser lever to drain the contents out of each bowl. If the mixture is not frozen, hold the container up to the tap to reduce splashing.
- 2 Once the bowls are empty, turn the main power switch to the OFF (O) position.

continued...

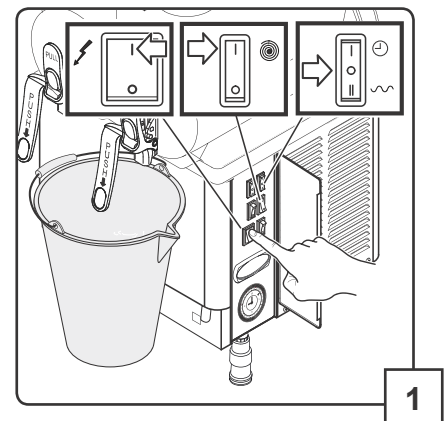

**Preventive Maintenance (cont.)**

**Remove the Mixing Bowls and Lids**

- 3 Remove the handle assemblies from the bowl taps by pushing in on the top of the handle with your thumb while pulling up on the bottom with your index finger.
- 4 Disconnect the lid light plugs from the sockets behind the mixing bowls.
- 5 Lift off the lids. Raise the front part of each bowl to release. Remove each bowl from its seat by pushing and tapping lightly on the rear.
- 6 Pull the bowl seal off of the back of each bowl and discard.
- 7 Pull forward on each auger to remove it from the drum. Remove and discard the auger seals.

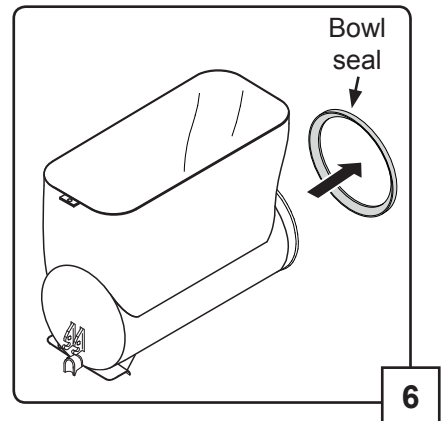
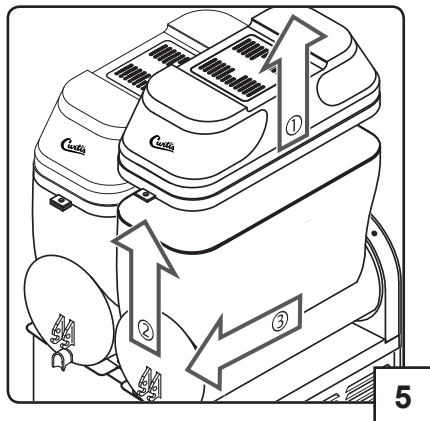
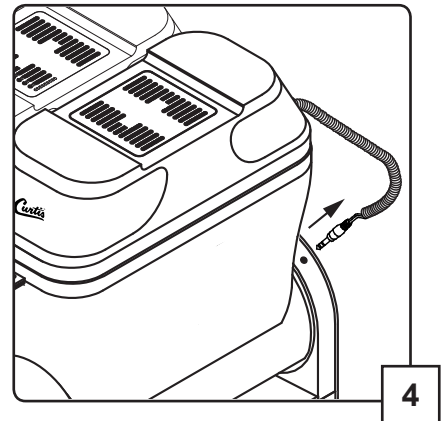
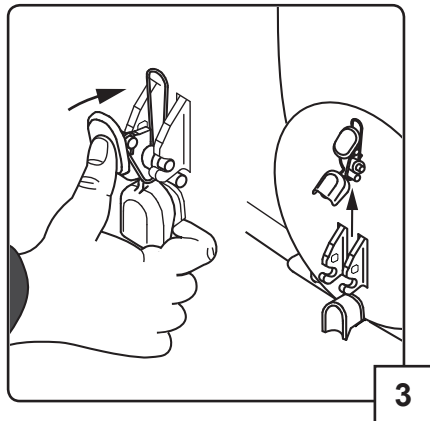

**Replace Seals and Reassemble**

- 8 Using a pair of pliers, grasp the outside of each drum bushing. While rocking it back and forth, pull out on the bushing, until it comes free from the drum. Discard the bushings.
- 9 Lubricate the inside of the new bushings with food grade lubricant (Curtis PN [WC-4916](#)).
- 10 Install the new bushings in place of the old ones removed in step 8.

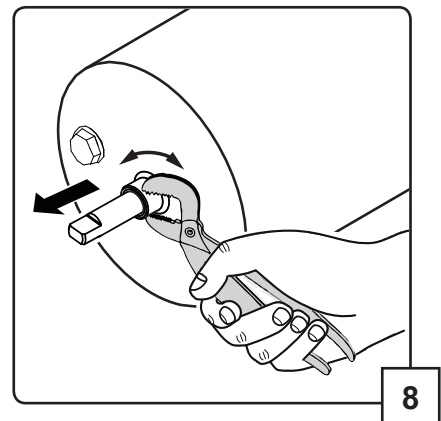
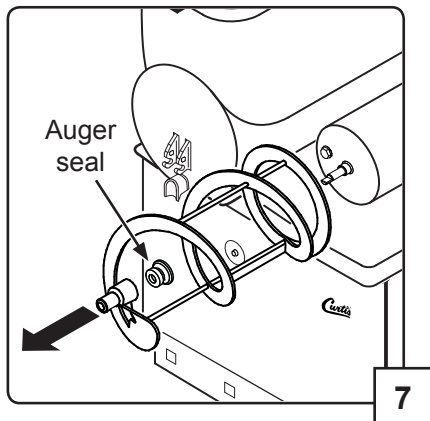

continued...

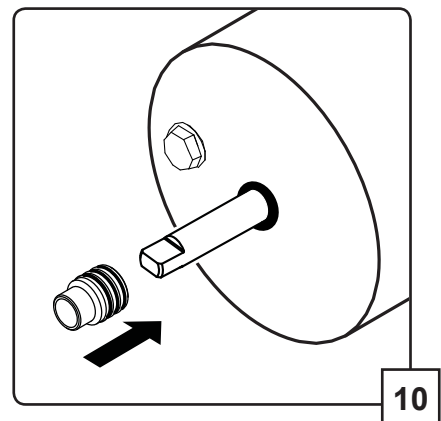
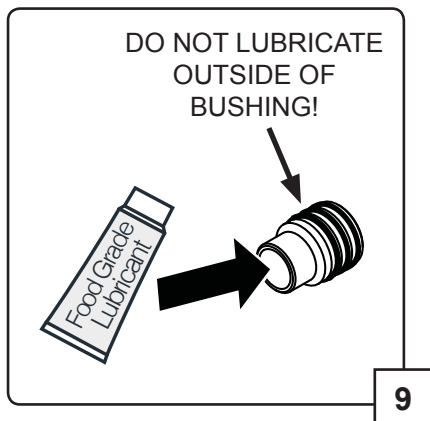

**Replace Seals and Reassemble (cont.)**

11 Install new auger seals on each auger.

12 Using food grade lubricant (Curtis PN WC-4916), lubricate the inside of each auger seal.

13 Reinstall the augers. Rotate each auger until it engages completely.

14 Lubricate the inner surface on each bowl seal with food grade lubricant. Install a bowl seal on the back of each bowl.

15 Set the mixing bowls back in place. Make sure that the lip on the bottom of each bowl rests inside the front trim on the top of the chassis.

16 Lubricate the tap mounting slots on the front of each mixing bowl with food grade lubricant.

17 Remove and discard the existing tap seals from the tap handle assemblies.

18 Install new tap seals.

continued...

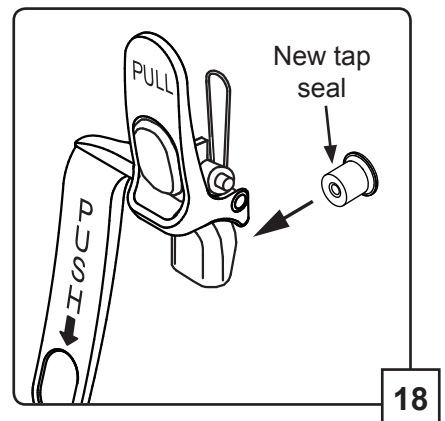
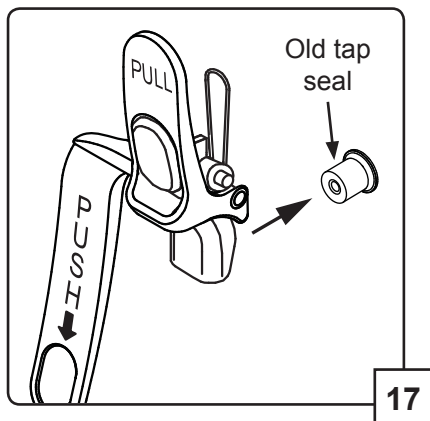
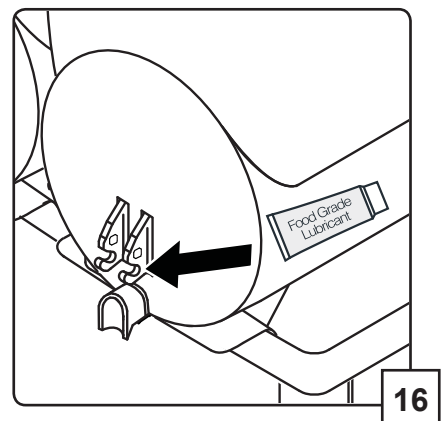
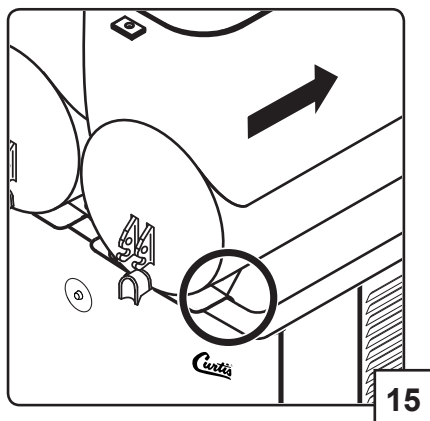
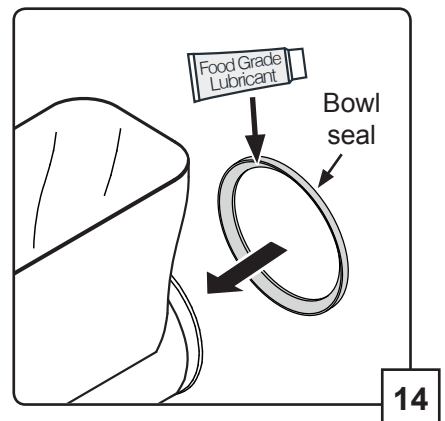
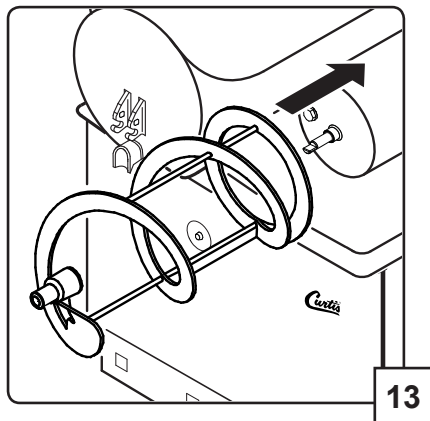
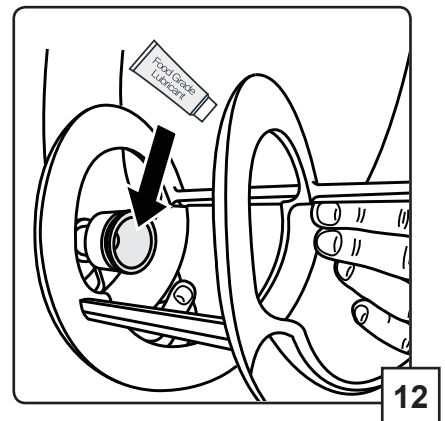
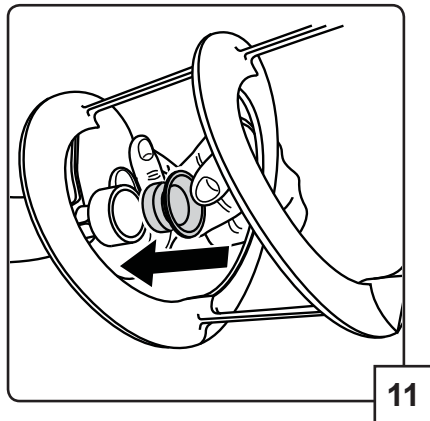

**Replace Seals and Reassemble (cont.)**

19 Prepare the tap handle assembly for attachment. Lubricate the red rubber seal on the back of the tap handle assembly with food grade lubricant (Curtis PN [WC-4916](#)). Insert the seal into the tap hole on the bottom of the bowl. Line up the spring and the middle pins on the handle, as shown. **NOTE:** Later versions of the mixing bowl have a hook to help line up the spring.

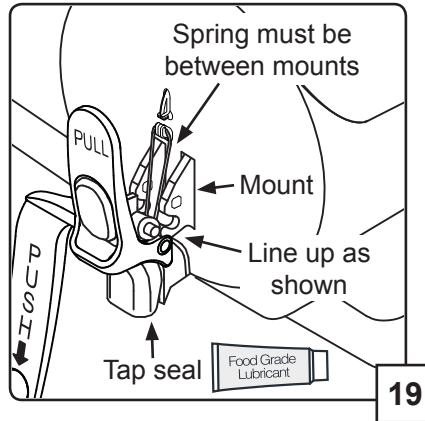

20 Attach the tap handle assembly. Push in with your thumb on the center of the handle until the handle assembly pops into place.

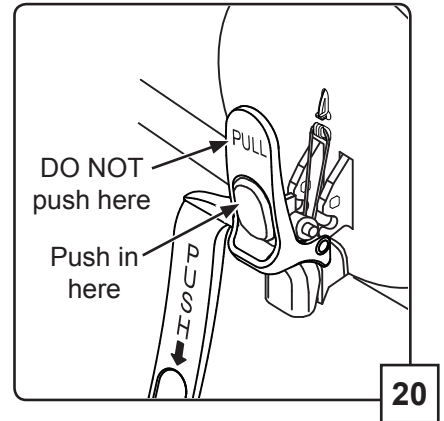

21 Reinstall each lid and insert the light plug into the socket behind each mixing bowl.

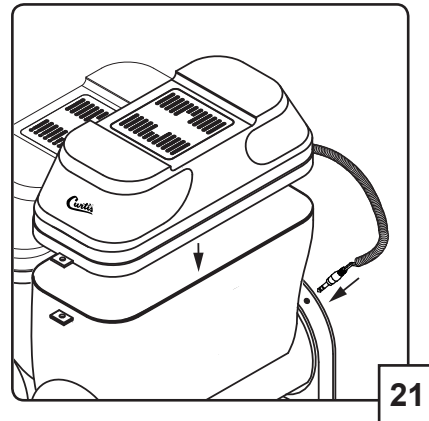

CFB3 - Three Bowl Frozen Beverage Machine

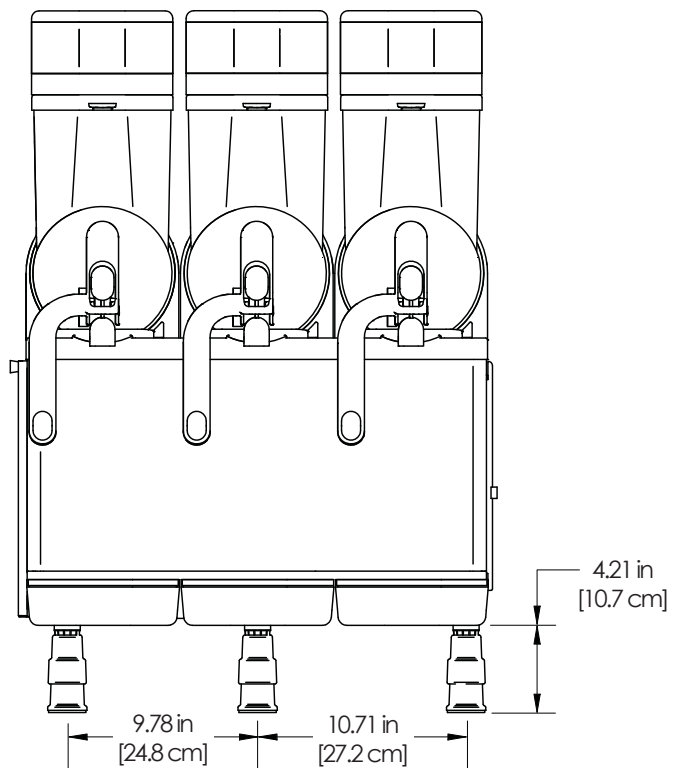
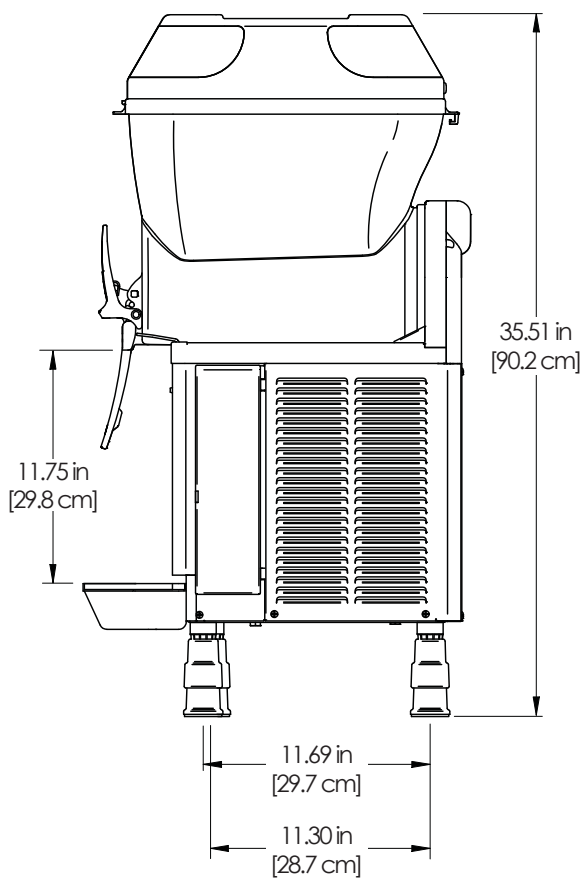
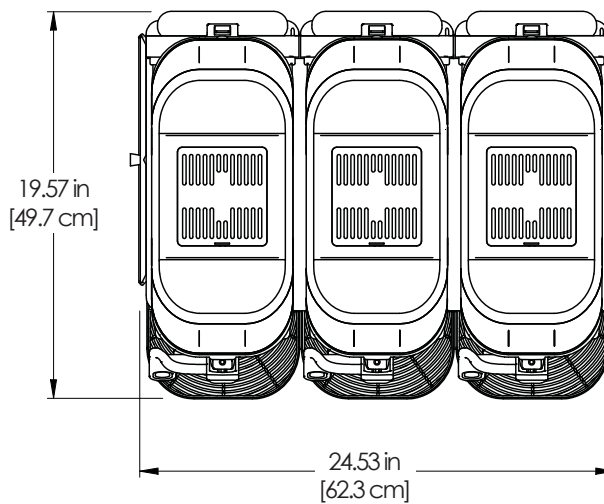

CFB3 - Main Chassis - Exploded View

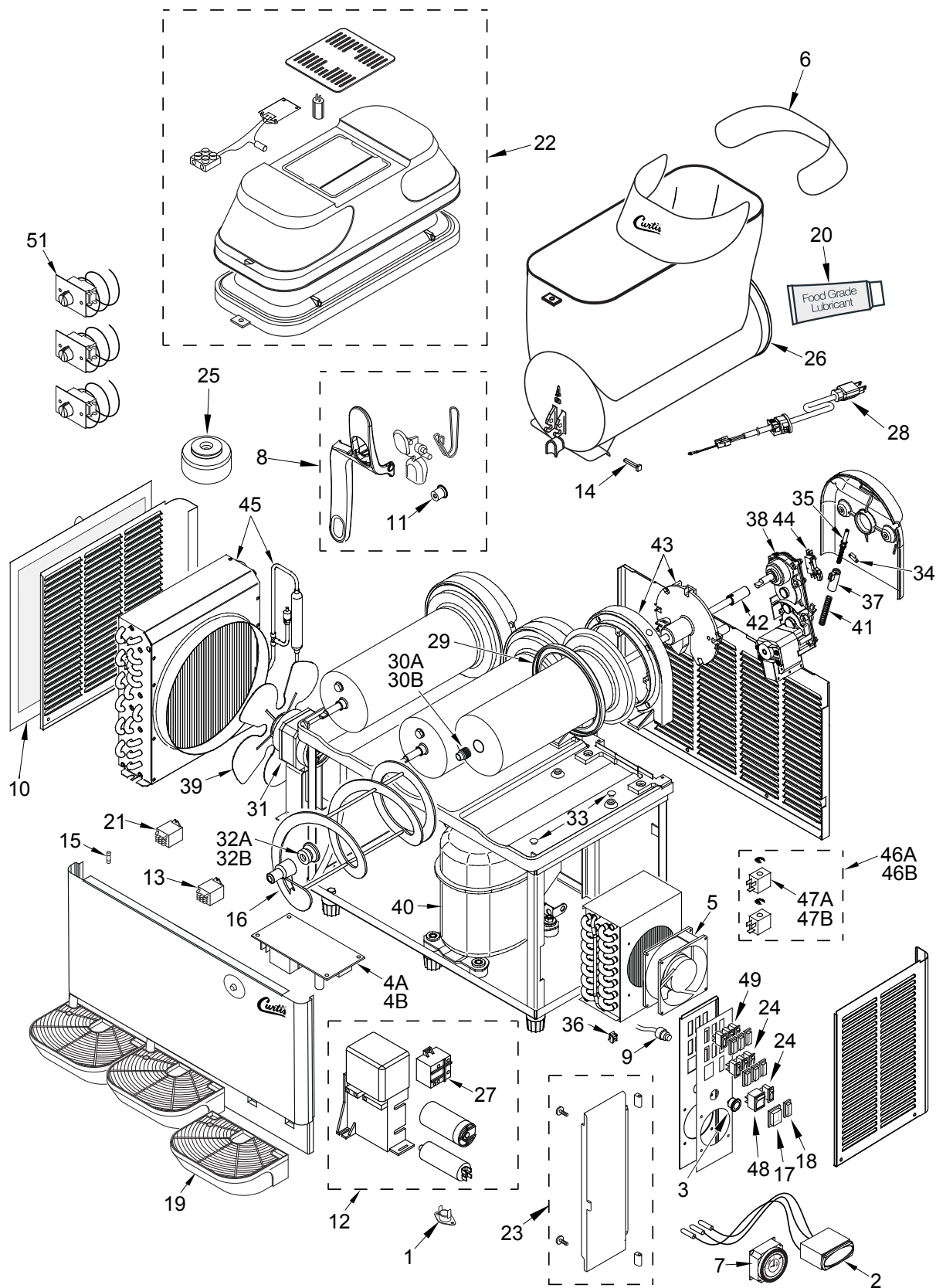

## CFB3 - Main Chassis - Parts List

ITEM #	PART #	DESCRIPTION
1 <sup>a</sup>	WC-100186	THERMAL PROTECTOR
2 <sup>a</sup>	WC-100192	ELECTRONIC TEMPERATURE VISUAL DISPLAY
3	WC-100100	DRAIN RACOR (DRAIN PIPE FITTING)
4A <sup>a</sup>	WC-100151&	ELECTRONIC REGULATOR (UNITS BUILT BEFORE 08/18)
4B <sup>a</sup>	WC-100199	ELECTRONIC REGULATOR 12V.V10+ TOR (UNITS BUILT 08/18 AND LATER)
5	WC-100129	FAN MOTOR 120X120X38 115V CFB
6	WC-100005	TRANSPARENCY
7	WC-100103*	MECHANICAL TIMER
8	WC-100001*	TAP SET GNW - BLACK (ADA-LONG HANDLE)
9 <sup>b</sup>	WC-100097*	CUT OFF PRESSURE CFB
10	WC-100094*	FILTER EXT. CONDENS. COMP. USA 05 CFB
11	WC-100010*	TAP SEAL, CFB
12	WC-100123	COMPRESSOR OPERATION BOX
13	WC-100109*	RELE FINDER 60.63 110V/60HZ (10A)
14	WC-100013*	TAP LOCK ROD - BLACK
15	WC-100088*	FUSE 5A
16	WC-100015*	AUGER, CFB
17	WC-100087*	SWITCH PROTECTION 22 X 30
18	WC-100086*	SWITCH PROTECTION 11 X 30
19	WC-100018*	DRIPPING TRAY+GRATING GT BLACK
20	WC-4916	LUBRICANT, GREASE HEAVY DUTY PC'S 4oz
21	WC-100023*	RELAY (30 AMP)
22	WC-100024	BOWL COVER SET GT - BLACK (COMPLETE)
23	WC-100025*	COMMAND COVER+ TECH SUPPORT ADH + HINGES+ SCREW
24	WC-100084*	SWITCH-BLACK
25	WC-100079*	COMPLETE TRANSFORMER
26	WC-100028*	BOWL SET GNW
27	WC-100120*	COMPRESSOR RELAY
28	WC-100171*	POWER CABLE
29	WC-100253*	BOWL SEAL, CFB/CFBX
30A	WC-100195	DRUM BUSHING, CFB (COMES WITH O-RINGS INSTALLED)
30B	WC-100195K*	KIT, BUSHING AND LUBRICANT, WC-100195, WC-4917

ITEM #	PART #	DESCRIPTION
31	WC-100074*	FAN MOTOR 16W 115/60
32A	WC-100196	AUGER SEAL, CFB
32B	WC-100196K*	KIT, SEAL AND LUBRICANT, WC-100196, WC-4917
33	WC-100035*	UPPER TRAY CAP - BLACK
34	WC-100036*	REGULATION SYSTEM SUBJECTION (ADJUSTMENT PIN RETAINER)
35	WC-100037*	REGULATION ROD
36	WC-100073*	SPECIAL NUT TYPE CWP M4
37	WC-100039*	REGULATION SYSTEM SPRING GUIDE
38	WC-100040*	GEAR MOTOR ELCO MONO 115/60HZ
39	WC-100072*	FAN MOTOR BLADES Ø250 X 28
40	WC-100119	COMPRESSOR CFB3
41	WC-100043*	REGULATION SPRING
42	WC-100044*	TRANSMISSION SHAFT SET
43	WC-100045	EVAPORATOR SUPPORT SET PZ-1+ PZ-2 - BLACK
44	WC-100046*	MINIRRUPTOR (CONTROL SWITCH)
45	WC-100069	CONDENSER + FILTER
46A	WC-100115	TRIPLE ELECTROVALVE CEME 115V/60HZ
46B	WC-100116	TRIPLE ELECTROVALVE OLAB 115V/60HZ
47A	WC-100064	COIL, SOLENOID 115V 60HZ, CFB
47B	WC-100063	GAS ELECTROVALVE BOBBIN OLAB 1
48	WC-100061*	GREEN MAIN SWITCH
49	WC-100060*	SWITCH-BLACK
50	WC-100078*	COMPRESSOR CAPACITOR
51	WC-100057*	MECHANICAL THERMOSTAT
52	WC-100201	KIT. PREVENTIVE MAINTENANCE, CFB, 6 MONTH (CONSISTS OF 2 EACH OF ITEMS 30A AND 32A)
53	WC-100202	KIT. PREVENTIVE MAINTENANCE, CFB, 1 YEAR (CONSISTS OF 2 EACH OF ITEMS 11, 29, 30A AND 32A)

\* Recommended parts to stock

<sup>a</sup> Units equipped with a temperature display only

<sup>b</sup> Units equipped without a temperature display only

& Supersedes PN WC-100187

CFB3 - Three Bowl Without Digital Temperature Display

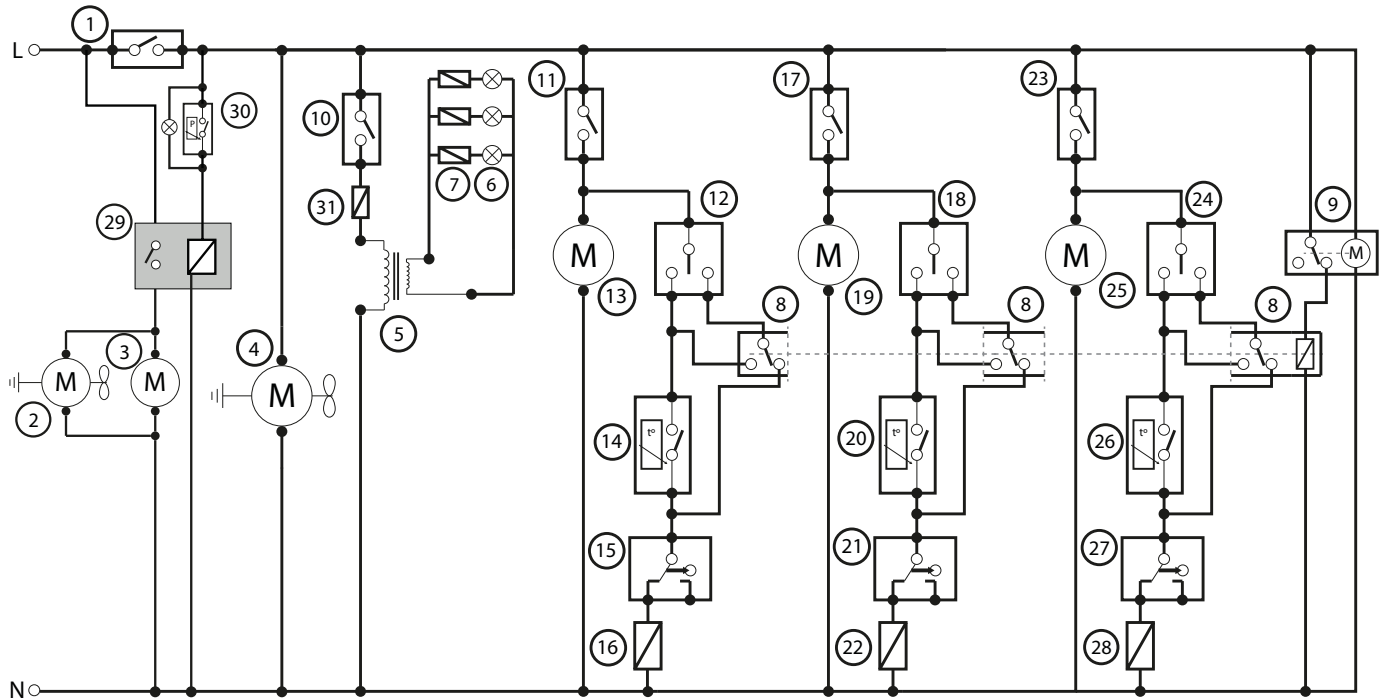

Power Consumption:  
115 Vac, 60 Hz., 14.8 A

N°	Description
1	Main power switch
2	Fan motor 1
3	Compressor
4	Fan motor 2
5	Transformer
6	Tank cover light
7	Fuse
8	Relay
9	Timer
10	Tank lights switch
11	Left mixing switch
12	Left refrigeration switch
13	Left auger motor
14	Left thermostat
15	Left micro regulation
16	Left electrovalve

N°	Description
17	Middle mixing switch
18	Middle refrigeration switch
19	Middle auger motor
20	Middle thermostat
21	Middle micro regulation
22	Middle electrovalve
23	Right mixing switch
24	Right refrigeration switch
25	Right auger motor
26	Right thermostat
27	Right micro regulation
28	Right electrovalve
29	Relay
30	Compressor cutoff (reset) switch
31	Fuse

CFB3 - Three Bowl With Digital Temperature Display - built before 08/18

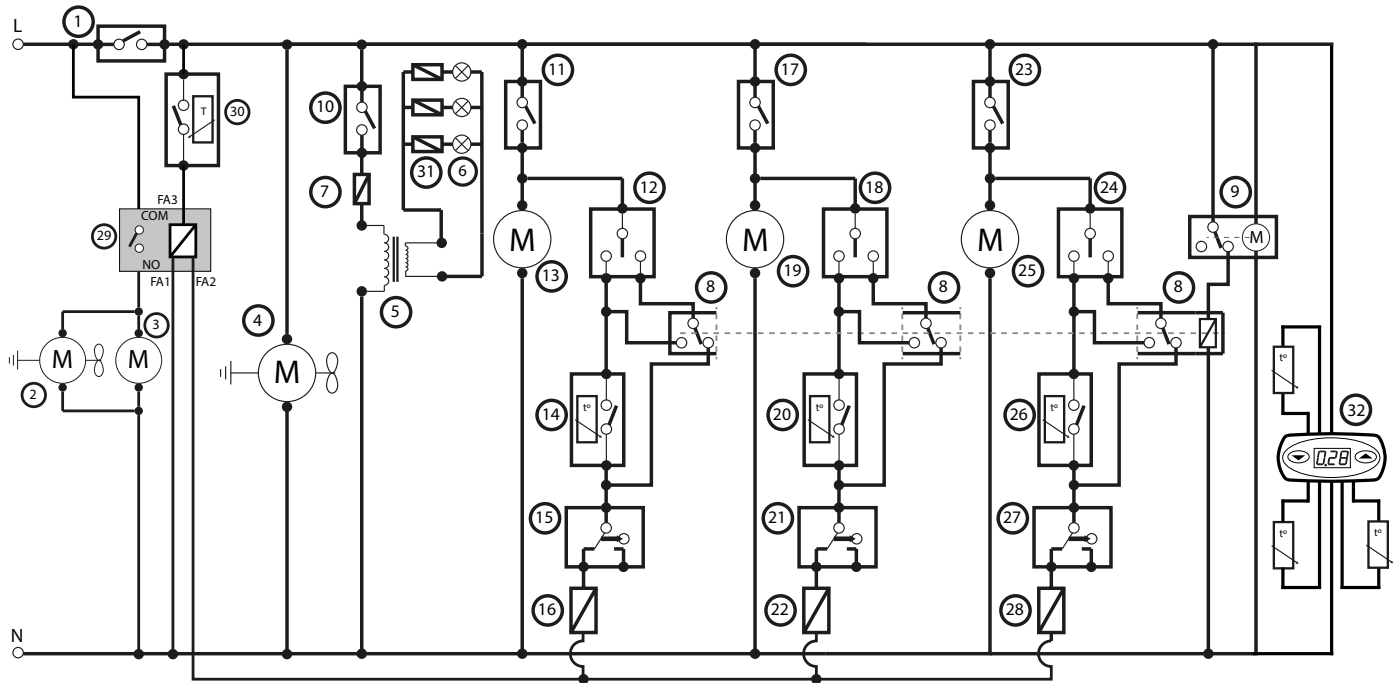

Power Consumption:  
115 Vac, 60 Hz., 14.8 A

N°	Description
1	Main power switch
2	Fan motor 2
3	Compressor
4	Fan motor 1
5	Transformer
6	Tank cover light
7	Fuse
8	Relay
9	Timer
10	Tank lights switch
11	Left mixing switch
12	Left refrigeration switch
13	Left auger motor
14	Left thermostat
15	Left micro regulation
16	Left electrovalve

N°	Description
17	Middle mixing switch
18	Middle refrigeration switch
19	Middle auger motor
20	Middle thermostat
21	Middle micro regulation
22	Middle electrovalve
23	Right mixing switch
24	Right refrigeration switch
25	Right auger motor
26	Right thermostat
27	Right micro regulation
28	Right electrovalve
29	Electronic regulator
30	Thermal protector
31	Fuse holder
32	Temperature Display

CFB3 - Three Bowl With Digital Temperature Display - built 08/18 and later

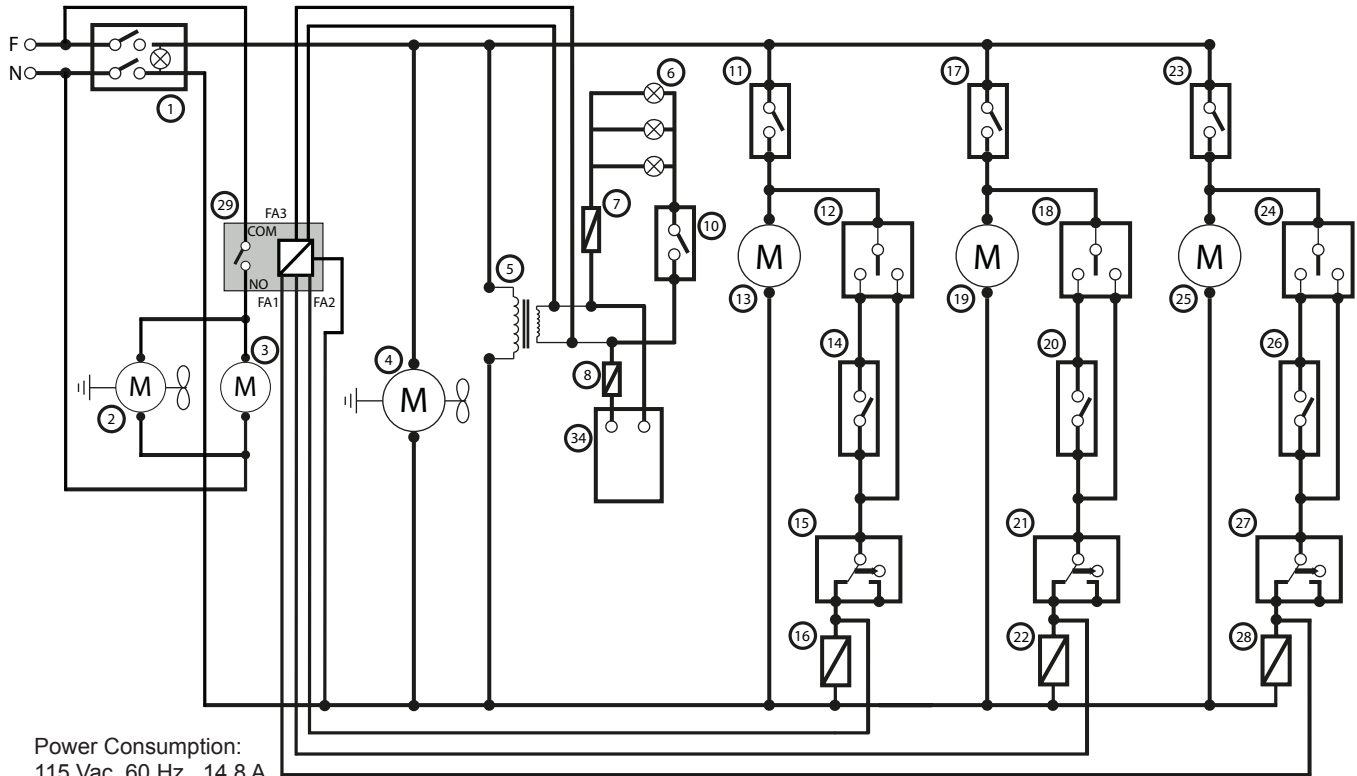

Power Consumption:  
115 Vac, 60 Hz., 14.8 A

N°	Description
1	Main power switch
2	Fan motor 2
3	Compressor
4	Fan motor 1
5	Transformer
6	Tank cover light
7	Fuse
8	Relay
9	Timer
10	Tank lights switch
11	Left mixing switch
12	Left refrigeration switch
13	Left auger motor
14	Left thermostat
15	Left micro regulation
16	Left electrovalve
17	Middle mixing switch

N°	Description
18	Middle refrigeration switch
19	Middle auger motor
20	Middle thermostat
21	Middle micro regulation
22	Middle electrovalve
23	Right mixing switch
24	Right refrigeration switch
25	Right auger motor
26	Right thermostat
27	Right micro regulation
28	Right electrovalve
29	Compressor control
30	Thermal disk
31	Fuse holder
32	Thermal disk pilot
33	Temperature display fuse
34	Temperature display

**Unit Does Not Turn ON**

- 1 Make sure that the circuit breaker for the electrical outlet is not tripped and is turned on.
- 2 Make sure that the power cord is properly connected to the electrical outlet.
- 3 Make sure that the main power switch is on.

**Mixture Does Not Freeze**

**NOTE:** When the main power switch is turned from the off to the on position, it can take up to 5 minutes for the compressor and related fans to come on. This is normal operation and is designed to increase the life of the compressor.

- 1 Make sure that temperature of the operating environment is within minimum and maximum specified in the *SPECIFICATIONS* section.
- 2 See *Check for Proper Ventilation* later in this section.
- 3 Make sure that the refrigeration switch is in the ON (I) position.
- 4 If using a slush mixture, make sure that it is properly diluted. Proper sugar content is 11 - 20%.
- 5 Make sure that the clock is set to the current time and that the timer is set to freeze at the current time. See *Setting the Timer Clock* (CFB2 and CFB3 only).
- 6 Make sure that the thickness setting is not set too low. See *Adjusting Beverage Thickness*.
- 7 Check to see if the compressor reset switch inside the control panel is "popped out" (CFB2 and CFB3 without temperature display only). Push in to reset (see diagram below) and allow the sealed system to cool before restarting the unit. If the reset switch continues to pop out, call for service.

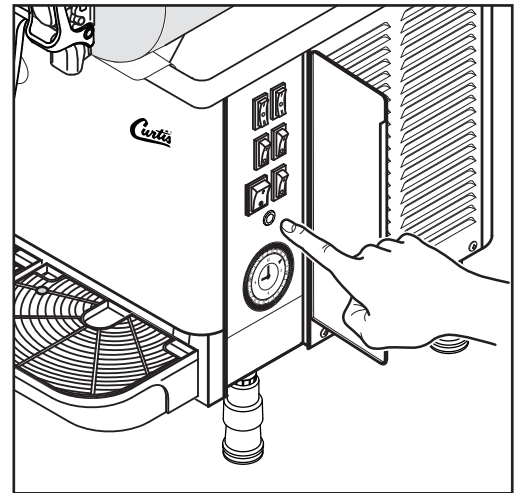

**Compressor Reset Switch  
(some models)**

**Tap Leaks**

- 1 Make sure that the (red) tap gasket is properly lubricated and is not worn out.
- 2 Make sure that the tap handle assembly is properly seated.

**Beverage Does Not Come Out of Tap**

This problem is usually caused by a mixture that is too thick or ice chunks forming in the bowl.

- 1 If using a slush mixture, make sure that it is properly diluted. Proper sugar content is 11 - 20%.
- 2 Make sure the thickness setting on the back of unit is not set too high.

**Leak at Back of Mixing Bowl**

- 1 Make sure that the mixing bowl seal is properly lubricated and is not worn out.
- 2 Make sure that the mixing bowl is properly seated

**Auger Does Not Turn or is Noisy**

- 1 Make sure the mixing switch is turned on.
- 2 If using a slush mixture, make sure that it is properly diluted. Proper sugar content is 11 - 20%. An improperly diluted slush mixture can cause ice chunks that can interfere with proper auger operation.
- 3 Make sure the auger seal is properly installed and lubricated.

continued...

**High Pressure/Temperature Light On**

CFB2 and CFB3 only. Turn off the main power switch\* and check the following:

- 1 See *Check for Proper Ventilation* below.
- 2 If the light still comes on during operation, turn off the main power switch and call for service.

\* On units equipped with a temperature display, the system is designed to reset itself automatically after the main power switch has been off for 5 minutes.

**Check for Proper Ventilation**

- 1 The unit will not function properly if there is not sufficient air space (4 inches minimum on back and sides).
- 2 Make sure that the filter (CFB2 and CFB3 only) is clean and that all ventilation grills are not blocked or dirty. See the *CLEANING INSTRUCTIONS* section.
- 3 Make sure that the unit is not close to sources of heat that could affect proper operation (heaters, cooking grills, etc.)

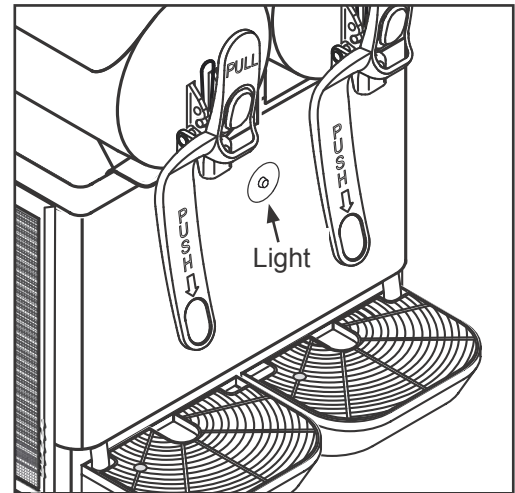

Models CFB2 and CFB3 with temperature display only. See list below to determine possible problem when an error code appears on the display.

ERROR CODE	PROBLEM	REMEDY
A1	Temperature probe for bowl 1 disconnected	Call for service.
A2	Bowl 1 too hot or temperature probe shorted	See "Check for Proper Ventilation" in <i>TROUBLESHOOTING</i> section. If ventilation is OK, call for service.
A3	Temperature probe for bowl 2 disconnected	Call for service.
A4	Bowl 2 too hot or temperature probe shorted	See "Check for Proper Ventilation" in <i>TROUBLESHOOTING</i> section. If ventilation is OK, call for service.
A5	Temperature probe for bowl 3 disconnected	Call for service.
A6	Bowl 3 too hot or temperature probe shorted	See "Check for Proper Ventilation" in <i>TROUBLESHOOTING</i> section. If ventilation is OK, call for service.

Wilbur Curtis Co., Inc. certifies that its products are free from defects in material and workmanship under normal use. The following limited warranties and conditions apply:

- 5** years, parts and 1 year labor, from the original date of purchase on compressors on refrigeration equipment
- 3** years, parts and labor, from original date of purchase on digital control boards
- 2** years, parts, from original date of purchase on all other electrical components, fittings and tubing
- 1** year, labor, from original date of purchase on all other electrical components, fittings and tubing

Additionally, Wilbur Curtis Co., Inc. warrants its grinding burrs for forty (40) months from the date of purchase or 40,000 pounds of coffee, whichever comes first. Stainless steel components are warranted for two (2) years from the date of purchase against leaking or pitting. Replacement parts are warranted for ninety (90) days from the date of purchase or for the remainder of the limited warranty period of the equipment in which the component is installed.

All in-warranty service calls must have prior authorization. For authorization, call the Technical Support Department at 800-995-0417. Additional conditions may apply. Go to [www.wilburcurtis.com](http://www.wilburcurtis.com) to view the full product warranty information.

## CONDITIONS & EXCEPTIONS

The warranty covers original equipment at time of purchase only. Wilbur Curtis Co., Inc., assumes no responsibility for substitute replacement parts installed on Curtis equipment that have not been purchased from Wilbur Curtis Co., Inc. Wilbur Curtis Co., Inc. will not accept any responsibility if the following conditions are not met. The warranty does not cover:

- **Adjustments and cleaning:** *The resetting of safety thermostats and circuit breakers, programming and temperature adjustments are the responsibility of the equipment owner. The owner is responsible for proper cleaning and regular maintenance of this equipment.*
- **Replacement of items subject to normal use and wear:** *This shall include, but is not limited to, spray heads, faucets, light bulbs, shear disks, "O" rings, gaskets, silicone tubing, silicone elbows, canister assemblies, whipper chambers and plates, mixing bowls, agitation assemblies and whipper propellers.*

The warranty is void under the following circumstances:

- **Improper operation of equipment:** *The equipment must be used for its designed and intended purpose and function.*
- **Improper installation of equipment:** *This equipment must be installed by a professional technician and must comply with all local electrical, mechanical and plumbing codes.*
- **Improper voltage:** *Equipment must be installed at the voltage stated on the serial plate supplied with this equipment.*
- **Improper water supply:** *This includes, but is not limited to, excessive or low water pressure and inadequate or fluctuating water flow rate.*
- **Damaged in transit:** *Equipment damaged in transit is the responsibility of the freight company and a claim should be made with the carrier.*
- **Abuse or neglect (including failure to periodically clean or remove lime accumulations):** *The manufacturer is not responsible for variation in equipment operation due to excessive lime or local water conditions. The equipment must be maintained according to the manufacturer's recommendations.*

**Repairs and/or Replacements** are subject to Curtis' decision that the workmanship or parts were faulty and the defects showed up under normal use. All labor shall be performed during regular working hours. Overtime charges are the responsibility of the owner. Charges incurred by delays, waiting time, or operating restrictions that hinder the service technician's ability to perform service is the responsibility of the owner of the equipment. This includes institutional and correctional facilities. Wilbur Curtis Co., Inc. will allow up to 100 miles, round trip, per in-warranty service call.

**Return Merchandise Authorization (RMA):** All claims under this warranty must be submitted to the Wilbur Curtis Technical Support Department prior to performing any repair work or return of this equipment to the factory. **All returned equipment must be properly re-packaged in the original carton and received by Curtis within 45 days following the issuance of a RMA.** No units will be accepted if they are damaged in transit due to improper packaging. **NO UNITS OR PARTS WILL BE ACCEPTED WITHOUT A RETURN MERCHANDISE AUTHORIZATION (RMA). THE RMA NUMBER MUST BE MARKED ON THE CARTON OR SHIPPING LABEL. All warranty claims must be submitted within 60 days of service. Invoices will not be processed or accepted without a RMA number. Any defective parts must be returned in order for warranty invoices to be processed and approved.** All in-warranty service calls must be performed by an authorized service agent. Call the Wilbur Curtis Technical Support Department to find an agent near you.