



G4 Omega Series 3.0/6.0 Gallon Coffee Brewing System



READ AND SAVE THESE INSTRUCTIONS

NOTICE TO INSTALLER: Please leave this booklet with the machine.

Key Features/Specifications/System Requirements.....FS37

Important Safeguards.....IS2

Installation Instructions (General).....II2

Installation Instructions (Leveling, Water Supply, Electrical).....II6

Operating InstructionsOI30

Cleaning Instructions (Brewer)CI13

Cleaning Instructions (Brew Basket)CI14

Cleaning Instructions (Thermal Dispensers)CI15

Programming GuidePG1

Rough-In Drawing.....RD43

Illustrated Parts/Recommended Parts (Main Chassis).....IP68

Illustrated Parts/Recommended Parts (Tank Assembly, Single).....IP70

Illustrated Parts/Recommended Parts (Tank Assembly, Twin, 208 Volt).....IP71

Illustrated Parts/Recommended Parts (Tank Assembly, Twin, 240 Volt).....IP72

Electrical Schematic (OMGS).....ES70

Electrical Schematic (OMGSG4-16).....ES71

Electrical Schematic (OMGTG4-208).....ES72

Electrical Schematic (OMGTG4)ES73

Electrical Schematic (OMGTG4-16).....ES74

Electrical Schematic (OMGTG4-30).....ES75

Troubleshooting Guide (General).....TG3

Troubleshooting Guide (SSR Circuit)TG7

Troubleshooting Guide (Diagnostics)TG11

Error CodesEC1

Product Warranty.....PW1

Contact Information

Wilbur Curtis Co., Inc.

6913 Acco Street | Montebello, CA 90640 US
 Phone: 323-837-2300 | Toll Free: 800-421-6150
 Email: csrcassistance@wilburcurtis.com | Web: www.wilburcurtis.com

For the latest specifications and information go to www.wilburcurtis.com
 Toll Free: 800-995-0417 | Monday - Friday 5:30 A.M. - 4:00 P.M. PT
 Email: techsupport@wilburcurtis.com

Due to continued product improvement, the products illustrated/photographed in this guide may vary slightly from the actual product.

Key Features

- High Volume Brewing – OMGT/OMGT10 brews 36 gallons of coffee per hour. OMGS brews 25 gallons of coffee per hour
- High Volume Tank Capacity – 6.5 gallons (Single), 14.5 gallons (Twin)
- High Volume Brew Basket – Can accommodate up to 28 oz. of ground coffee
- G4 Digital Control Board – Password protected, precise control over all aspects of brewing, including pre-infusion, pulse-brew and volume control
- Electrical Conversion – All Omega units ship standard from the factory as three phase. All units easily convert from three phase to single phase in the field.

Specifications (Selected Models)

Electrical Supply Requirements

MODEL #	DESCRIPTION	PHASE*	VOLTS	AMPS	HEATING CONFIG	WIRE	WATTS	HERTZ	GAL/HR
OMGS	Single (3.0 gallon)	3 PH	220 V	19.9 A	3 x 2500 W	4W + G	7600 W	50/60 Hz	23.3
		1 PH	220 V	23.2 A	2 x 2500 W	3W + G	5100 W	50/60 Hz	15.5
OMGS16	Single (3.0 gallon) with transformer	3 PH	220 V	19.9 A	3 x 2500 W	3W + G	7600 W	50/60 Hz	23.3
		1 PH	220 V	23.2 A	2 x 2500 W	2W + G	5100 W	50/60 Hz	15.5
OMGT	Twin (6.0 gallon), 208 Volt	3 PH	208 V	34.0 A	3 x 4000 W	4W + G	12200 W	50/60 Hz	36.0
		1 PH	208 V	39.4 A	2 x 4000 W	3W + G	8200 W	50/60 Hz	24.8
OMGT10	Twin (6.0 gallon), 240 Volt	3 PH	240 V	29.4 A	3 x 4000 W	4W + G	12200 W	50/60 Hz	36.0
		1 PH	240 V	34.2 A	2 x 4000 W	3W + G	8200 W	50/60 Hz	24.8
OMGT16	Twin (6.0 gallon), 208 Volt with transformer	3 PH	208 V	34.0 A	3 x 4000 W	3W + G	12200 W	50/60 Hz	36.0
		1 PH	208 V	39.4 A	2 x 4000 W	2W + G	8200 W	50/60 Hz	24.8

Export

OMGT30	Twin (6.0 gallon), export	3 PH 1 PH	415 V 415 V	21.0 A 20.0 A	3 x 4000 W 2 x 4000 W	3W + G 2W + G	15000 W 8200 W	50/60 Hz 50/60 Hz	36.0 24.8
--------	---------------------------	--------------	----------------	------------------	--------------------------	------------------	-------------------	----------------------	--------------

* All units ship configured for 3 phase operation and are field convertible to single phase

Dimensions

MODEL #	HEIGHT	WIDTH	DEPTH	SHIP WEIGHT	SHIP CUBE	WATER CONNECTOR	WATER PRESSURE	MIN. FLOW RATE
OMGS	40.13"	21.38"	23.25"	90.0 lbs	16.0 cu ft	3/8" flare	20 - 90 psi	4.0 gpm
OMGS16	40.13"	21.38"	23.25"	90.0 lbs	16.0 cu ft	3/8" flare	20 - 90 psi	4.0 gpm
OMGT	40.13"	36.50"	23.25"	160.0 lbs	30.7 cu ft	3/8" flare	20 - 90 psi	4.0 gpm
OMGT10	40.13"	36.50"	23.25"	160.0 lbs	30.7 cu ft	3/8" flare	20 - 90 psi	4.0 gpm
OMGT16	40.13"	36.50"	23.25"	160.0 lbs	30.7 cu ft	3/8" flare	20 - 90 psi	4.0 gpm

Export

OMGT30	40.13"	36.50"	23.25"	160.0 lbs	30.7 cu ft	3/8" flare	20 - 90 psi	4.0 gpm
--------	--------	--------	--------	-----------	------------	------------	-------------	---------

Following are the factory default settings for the Omega brewer:

- Brew Temperature = 200°F
- Water Bypass = LARGE: 20%
MEDIUM: 20%
SMALL: 10%
- Brew Volume = Large-Medium-Small
- Energy Save Mode = Off

Symbols



This is the safety alert symbol. It is used to alert you to potential physical injury hazards. Obey all safety messages that follow this symbol to avoid possible injury or death.



DANGER - Indicates a hazardous situation which, if not avoided, will result in death or serious injury.



WARNING - Indicates a hazardous situation which, if not avoided, could result in death or serious injury.



CAUTION - Indicates a hazardous situation which, if not avoided, could result in minor or moderate injury.



NOTICE - Indicates a situation which, if not avoided, could result in property damage.



IMPORTANT - Provides information and tips for proper operation.



SANITATION REQUIREMENTS



WARNING - This product can expose you to chemicals including Acrylamide and Bisphenol A (BPA), which are known to the State of California to cause cancer and birth defects or other reproductive harm. For more information visit www.P65Warnings.ca.gov.

Important Safeguards/Conventions



WARNING:

- Make sure that this appliance is installed and grounded according to the INSTALLATION INSTRUCTIONS by qualified personnel before attempting to use it. Failure to follow the INSTALLATION INSTRUCTIONS could result in personal injury or void the warranty.
- This appliance is designed for commercial use. Any service other than cleaning and preventive maintenance should be performed by an authorized Wilbur Curtis service technician.
- To reduce the risk of fire or electric shock, DO NOT open the service panels. There are no user serviceable parts inside.
- Keep hands, arms and other items away from hot surfaces of the unit during operation.
- Clean the appliance and any dispensers completely before using them for the first time according to the CLEANING INSTRUCTIONS. Clean them regularly as instructed in the CLEANING INSTRUCTIONS.
- Use this appliance only for its intended use, brewing/dispensing hot and/or cold beverages/water.
- This appliance is not intended for use by persons (including children) with reduced physical, sensory or mental capabilities or lack of experience and knowledge, unless they have been given supervision or instruction concerning use of the appliance by a person responsible for their safety. Children should be supervised to ensure that they do not play with the appliance.
- Avoid spillage onto the power (mains) connector.

CE Requirements

- This appliance must be installed in locations where it can be overseen by trained personnel.
- For proper operation, this appliance must be installed where the temperature is between 5°C to 35°C.
- Appliance shall not be tilted more than 10° for safe operation.
- An electrician must provide electrical service as specified in conformance with all local and national codes. For safe use, an all-pole disconnection must be incorporated into the fixed wiring in accordance with the wiring rules outlined in clause 7.12.2 of IEC 60335 for meeting the minimum electrical safety of this standard.
- This appliance must not be cleaned by water jet.
- This appliance can be used by persons aged from 18 years and above if they have been given supervision or instruction concerning use of the appliance in a safe way and if they understand the hazards involved.
- Keep the appliance and its cord out of reach of children aged less than 18 years.
- Appliances can be used by persons 18 years and above with reduced physical, sensory or mental capabilities or lack of experience and knowledge if they have been given supervision or instruction concerning use of the appliance in a safe way and understand the hazards involved.
- Children under the age of 18 years should be supervised to ensure they do not play with the appliance.
- If the power cord is ever damaged, it must be replaced by the manufacturer or authorized service personnel with a special cord available from the manufacturer or its authorized service personnel in order to avoid a hazard.
- Machine must not be immersed for cleaning.
- Cleaning and user maintenance shall not be made by children unless they are older than 18 years and supervised.
- This appliance is intended to be used in household and similar applications such as:
 - staff kitchen areas in shops, offices and other working environments;
 - by clients in hotels, motels and other residential type environments;
 - bed and breakfast type environments.
- This appliance not intended to be used in applications such as:
 - farm houses
- Access to the service areas permitted by Authorized Service personnel only.
- The A-Weighted sound pressure level is below 70 dBA.



WARNING: Installation is to be performed only by a qualified installer.



WARNING: Improper electrical connection may result in an electric shock hazard. This brewer must be properly grounded.



NOTICE: DO NOT connect this brewer to a hot water supply. The water inlet valve is not rated for hot water. Do not exceed the maximum water pressure stated in the *SPECIFICATIONS* section.



IMPORTANT: Observe all governing codes and ordinances.

Installation Instructions

Installation Requirements

- A secure surface capable of supporting the weight of the appliance.
- For units without an attached cord set: Appropriately sized, UL listed, grounding type power cable to meet the electrical specifications for the appliance. If you have questions about the correct cable size and length, consult a qualified installer. If the appliance will be hard wired to a junction box, the power cable must be long enough so that the unit can be moved for cleaning underneath.
- A grounded electrical connection to an electrical circuit that meets the electrical specifications of the appliance (see *SPECIFICATIONS*). The circuit must be protected by the appropriate sized circuit breaker. If you are not certain that the existing circuit meets the requirements for your unit, consult a licensed electrician.
- A water filtration system is required to maintain trouble-free operation. Wilbur Curtis Co., Inc. recommends a Wilbur Curtis approved water filter. See the Curtis Equipment Catalog for a full line of Wilbur Curtis approved water filters.
- Potable water supply line connection from the water filter capable of supplying the minimum flow rate required by the specifications. The water supply line must be able to connect to the flare fitting on the back of the unit. See the *SPECIFICATIONS* section for the correct size. The water line should also be capable of being controlled by a shut off valve. Do not connect the water line to a saddle valve or needle valve.



NSF International requires the following water connection:

- 1 A quick disconnect or additional coiled tubing (at least two times the depth of the appliance) is required so that it can be moved for cleaning underneath.
- 2 This equipment is to be installed with adequate back-flow protection to comply with applicable federal, state and local codes.
- 3 Water pipe connections and fixtures directly connected to a potable water supply shall be sized, installed and maintained in accordance with federal, state and local codes.

The International Plumbing Code of the International Code Council and the Food and Drug Administration (FDA) Food Code manual, direct that this equipment must be installed with adequate back-flow prevention in compliance with federal, state and local codes. For units installed outside of the U.S.A., make sure that the installation is in compliance with the applicable plumbing/sanitation code for your area.

Installation Requirements (cont.)

- The brewer must maintain a minimum distance of 4 inches from the chassis to the walls on the left, right and back sides (see below).
- The brewer must not have anything mounted above it or on top of it.

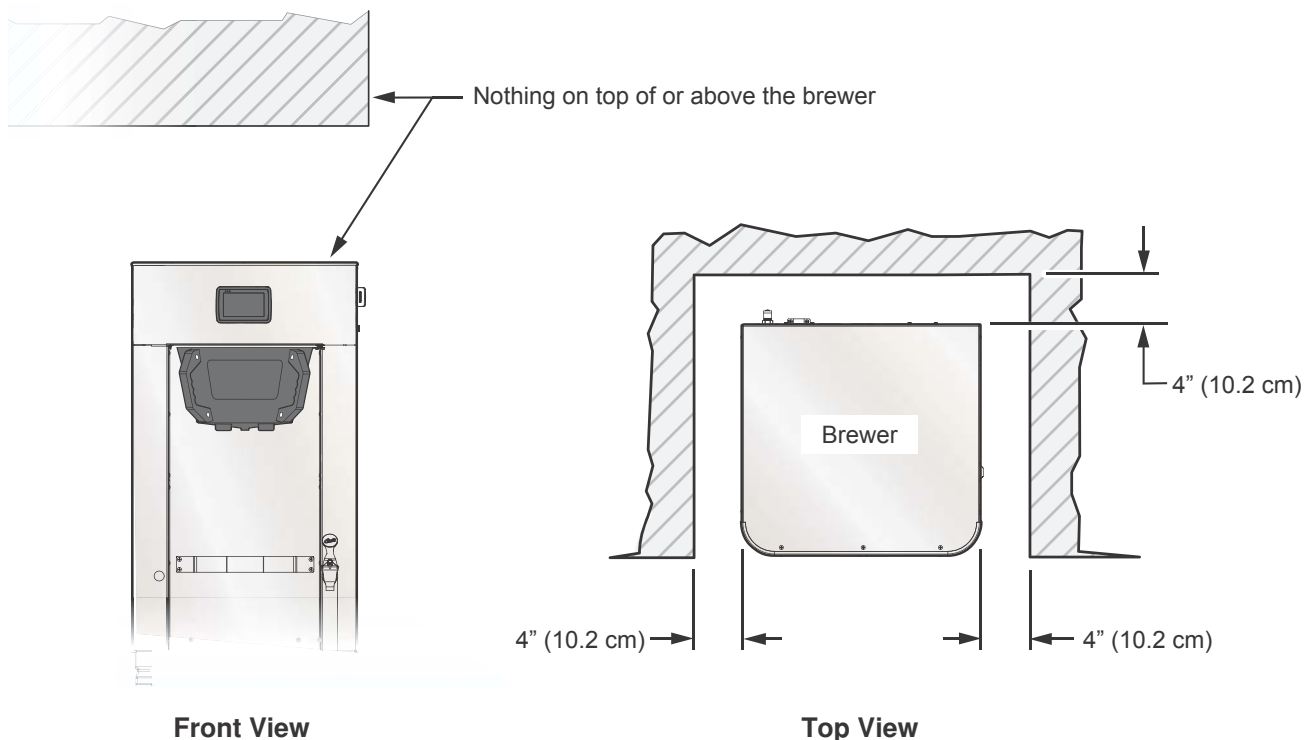

Installation

Leveling



WARNING: Use the leveling legs to level the brewer only. Do not use them to adjust brewer height. Do not extend them higher than necessary.

- 1 Position the brewer on the countertop. Level it left to right and front to back by turning the bottom of the legs.

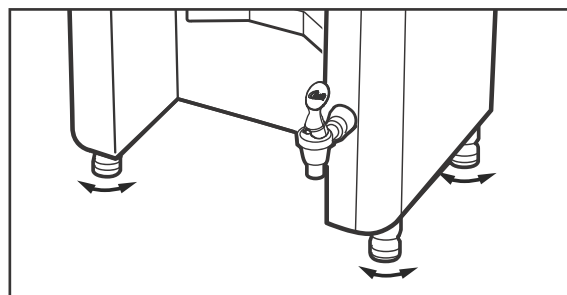

Connect the Water Supply

- 2 Flush the water supply line prior to installation to purge air and debris from the water filter and tubing.
- 3 Connect the water supply line to the flare fitting on the back of the brewer. Leave the water supply valve closed until the power is connected.

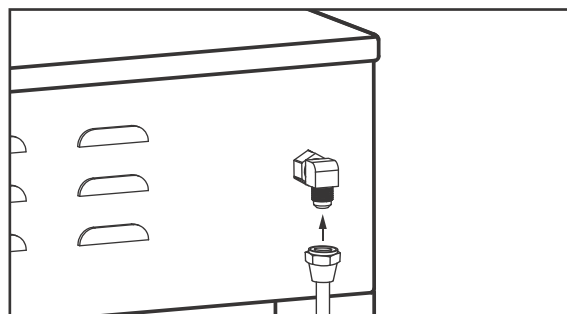

Installation (cont.)

Connect the Brewer Wiring



WARNING: Turn off power to the junction box at the circuit breaker panel before connecting the power cable to the brewer.

- 4 Remove the screws that hold the top panel in place and remove.
- 5 If the brewer will be operated using a single phase power supply:

DOMESTIC UNITS: Remove the cap from the jumper wire attached to the L3 terminal on the terminal block, then attach the exposed end of the jumper wire to the L2 terminal (L2 and L3 jumpered).

EXPORT UNITS: The L3 terminal is not used. Connect the power cable to terminals L1, L2 and GND (2W + G).

- 6 Loosen the strain relief on the back of the brewer.
- 7 Feed the end of the power cable into the brewer.
- 8 Connect the wires on the power cable to the terminal block inside.
- 9 Tighten the strain relief and replace the top panel.
- 10 Connect the power cable wires to the terminals in the junction box. See the ***ELECTRICAL SCHEMATIC*** for the power supply requirements.

Power Up the Brewer

- 11 Turn on the water supply valve.
- 12 Turn on the circuit breaker supplying power to the brewer.
- 13 Turn the power switch on the right side of the brewer to the ON position. The water tank will start to fill. While the tank is filling, inspect the water supply line for leaks.

continued...

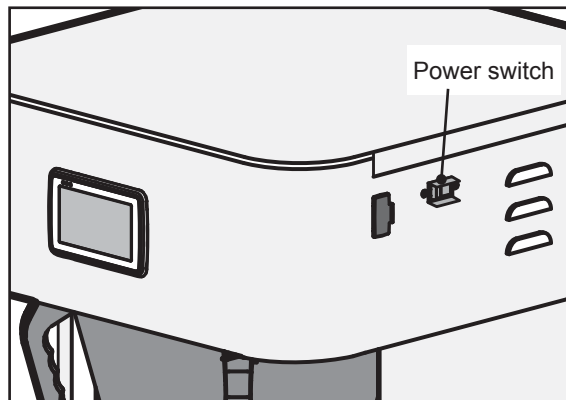
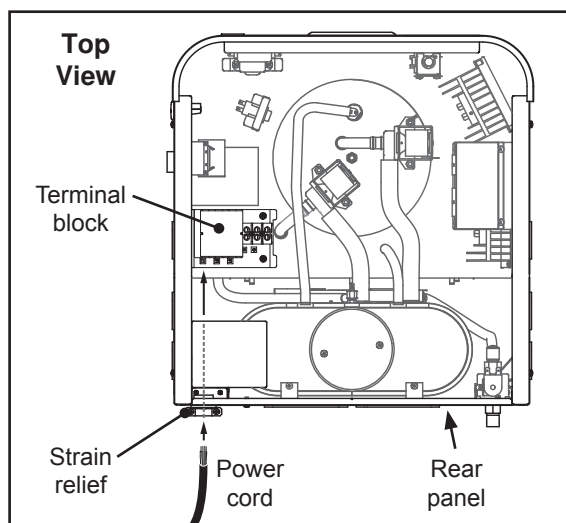
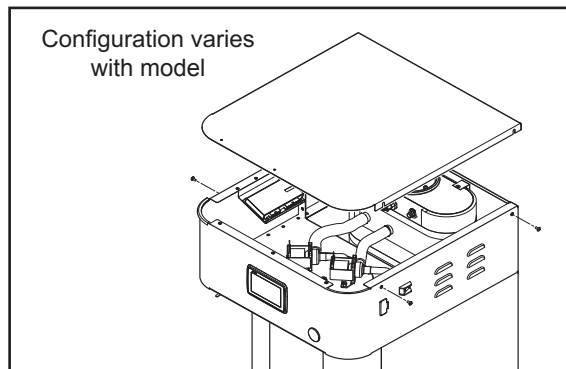

- 14 Go to the *PROGRAMMING GUIDE* section and program the brewer for the correct model and batch number.



IMPORTANT: When operating the brewer at higher elevations, reduce the factory set operating temperature (200°F) by 2°F for each 1000 feet of elevation above 4000 feet. See *PROGRAMMING GUIDE*.

- 15 When the water level in the tank rises to the correct volume, the heating elements will turn on automatically. Depending on the brewer capacity, the incoming water temperature and the electrical specifications, the water tank typically requires about 25 to 45 minutes to reach the factory set operating temperature. When the water has heated, “Ready to Brew” should be on the display.
- 16 Before brewing for the first time, dispense 32 ounces of hot water through the hot water faucet to help purge air from the tubing inside the brewer.
- 17 Brew a cycle of at least 192 ounces, to purge any remaining air from the tubing. See *OPERATING INSTRUCTIONS*. During the initial brew cycle and whenever the filter is replaced, you may hear the sounds of air being purged from the filter, tubing and water tank.

Brewing Instructions

WARNING - TO AVOID SCALDING, AVOID SPLASHING. Keep body parts clear of the brewer during brewing. Do not remove the brew basket while “Brewing” appears on the display.

The G4 Omega Brewer is factory preset for optimal performance.

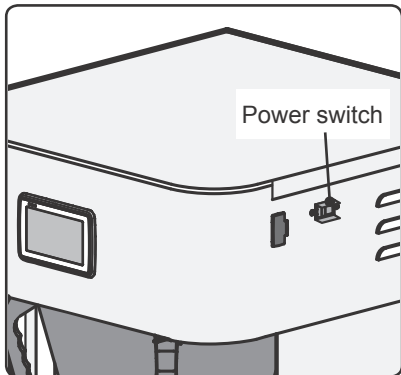

1 The brewer should be ON. Confirm this at the power switch on the side. “Ready to brew” should be on the display. If the brewer is connected to an inter-lock grinder, the grinder should be on. When inter-lock connection is made, grind coffee at this time.

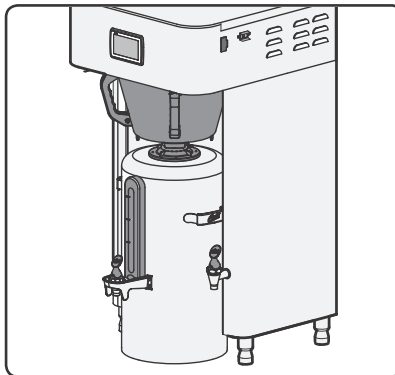

2 Center an empty dispenser under the brew basket.

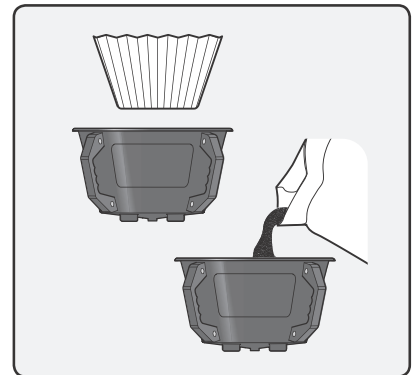

3 Insert a clean paper filter into the brew basket. Fill with the proper amount of ground coffee. Level the coffee in the filter.

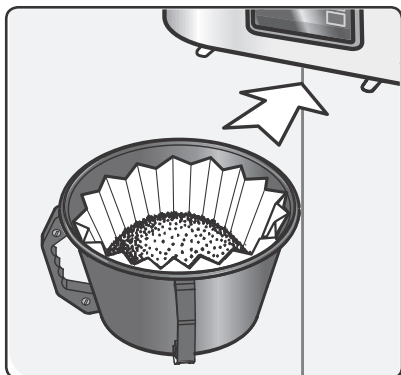

4 Slide the filled brew basket into the brew rails under the control panel. Slide it all the way back until it stops.

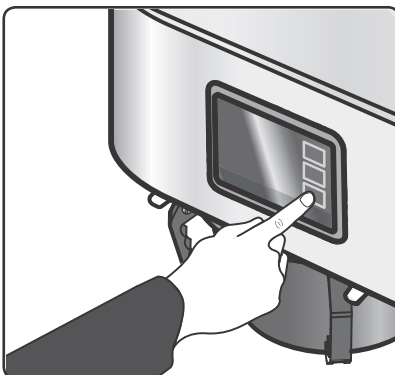

5 Hold your finger on the appropriate brew icon. As soon as you hear the click of the brew valve, lift your finger. Brewing will begin.

ENTER BREW CODE		
1	2	3
4	5	6
7	8	9
Del	0	OK

6 If a keypad appears on the display, the brew code feature is enabled (default is off). **Brewing will start immediately after you enter the brew code.** See the *PROGRAMMING GUIDE* to set up/disable the brew code.

The brewer will brew coffee based on the settings programmed into the universal control module (UCM). To change the settings, see the *PROGRAMMING GUIDE* section.



WARNING: HOT SURFACES - To avoid injury, allow the brewer and dispenser(s) to cool before cleaning.



NOTICE - Do not use cleaning liquids, compounds or powders containing chlorine (bleach) or corrosives. These products promote corrosion and will damage the finishes. **USE OF THESE PRODUCTS WILL VOID THE WARRANTY.**

Cleaning The Brewer - Daily



WARNING: DO NOT immerse the brewer in water or any other liquid.

The brewer should be OFF. Turn the brewer off by flipping the main power switch on the side to the OFF position.

- 1 Remove the dispenser(s). Wipe exterior brewer surfaces with a damp cloth to remove spills and debris.
- 2 Remove the brew basket(s) and clean them in a mild detergent solution. Use a soft bristled brush for hard to clean areas. Rinse with clean water, then dry.
- 3 Wipe the spray head area with a cloth soaked in a mild detergent solution. Rinse with a cloth soaked with clean water removing any residual detergent. Use a clean, soft cloth to dry.
- 4 Dump out the drip tray(s) (if applicable). Rinse with clean water, then dry with a soft, clean cloth.

Cleaning The Brewer - Weekly

The brewer should be OFF. Turn the brewer off by flipping the main power switch on the side to the OFF position.

- 1 Remove the spray head(s), unscrewing counterclockwise from the dome plate.
- 2 Thoroughly clean and rinse the dome plate area.
- 3 Clean the brew basket rails with a brush soaked with a mild detergent solution. Rinse the area with a cloth soaked with clean water, removing any residual detergent.
- 4 Dry the area with a soft, clean cloth.
- 5 Reattach the spray head(s).

Cleaning the Brew Basket Handles (Weekly)

Once a week clean the brew basket handles.

- 1 Prepare a mild solution of dishwashing detergent and warm water.
- 2 Remove the two handles from the brew basket. Use a slotted screwdriver to remove the four slotted screws that attach them.
- 3 Clean the brew basket with the mild detergent solution. Use a soft bristled brush for hard to clean areas. Rinse with clean water, then dry.
- 4 Use the soft bristled brush soaked in detergent to brush out the hard to reach recessed areas of the handle. Pay special attention to the attachment channels of the handle.
- 5 Rinse the handles to remove all detergent residue and air dry.
- 6 Reattach the handles onto the brew basket.

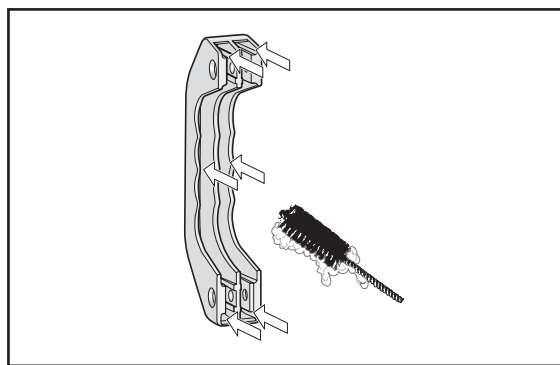
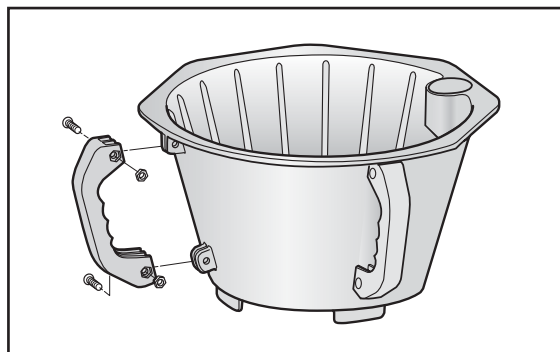

Cleaning the 3.0 Gallon Thermal Dispensers (Daily)



WARNING: DO NOT immerse thermal dispensers in water or any other liquid. Do not place the thermal dispensers in a dishwasher. Placing a thermal dispenser in a dishwasher will void the warranty. **To avoid damage, DO NOT use a brush to clean the faucet or the inside of the dispenser shank (outlet).**

Cleaning the Container

- 1 Prepare a mild solution of detergent and warm water. Remove the dispenser from the brewer and remove the lid. Rinse.
- 2 **Wash** - Wipe the exterior surfaces of the container with a sponge soaked with the detergent solution to remove spills and debris. Fill the liner with the detergent solution. Take a sponge brush and scrub out the stainless steel liner.
- 3 **Rinse** - Rinse with clean, warm water.
- 4 **Sanitize** - Sanitize the interior of the dispenser using a commercial sanitizer suitable for food grade applications. Swab, brush or pressure spray the sanitizing solution according to the directions on the package.
- 5 **Air Dry** - Turn the container upside down and allow to air dry.

Cleaning the Faucet Parts, Lid and Gauge Glass

- 1 Disassemble the faucet - Unscrew the handle/bonnet assembly from the top of the faucet and remove it. Inspect the seat cup for wear. Replace the seat cup if it is damaged.

Unscrew the two screws from the base of the gauge glass shield and remove the shield. Carefully lift the gauge glass tube from the silicone cup. Inspect the glass tube for cracks or chips. If broken, replace the glass with a new one.

- 2 **Wash** - Wash the faucet parts, the lid, the gauge glass and silicone parts in the detergent solution. Using the supplied brush, clean inside the fill tube on the lid. Clean the inside of the gauge glass with a gauge brush soaked with detergent solution.
- 3 **Rinse** - Thoroughly rinse all parts with clean, warm water.
- 4 **Sanitize** - After rinsing, place the lid, the faucet parts and the gauge parts in a sink to be sanitized. Immerse them in a commercial sanitizer suitable for food grade applications. Sanitize according to the directions on the package.
- 5 **Air Dry** - Allow all parts to thoroughly air dry.
- 6 **Reassemble** - When dry, reassemble the handle/bonnet. Hand tighten the handle/bonnet onto the top of the faucet assembly, reinstall the site gauge and cover. If replacing a broken gauge glass, carefully remove any traces of glass from the silicone parts before inserting the new gauge glass tube. Reinstall the lid.

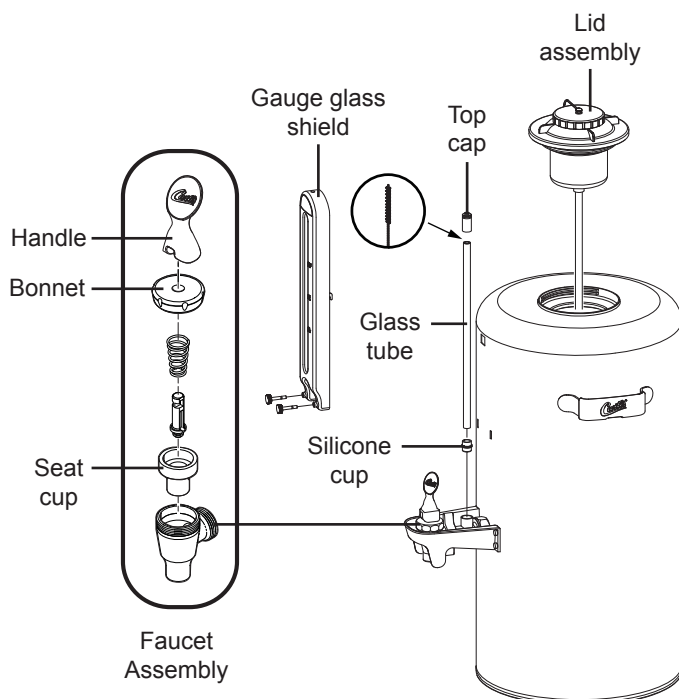

Touchscreen Control Module

The touchscreen turns on whenever power is provided to the brewer and the rear toggle switch is on. The symbol buttons on the screen control operation and programming. Pressing the on-screen symbols and buttons with your finger tip activates the various functions. The default screen, as well as additional control buttons are shown below. The configuration of the default screen varies depending on the brewer model.

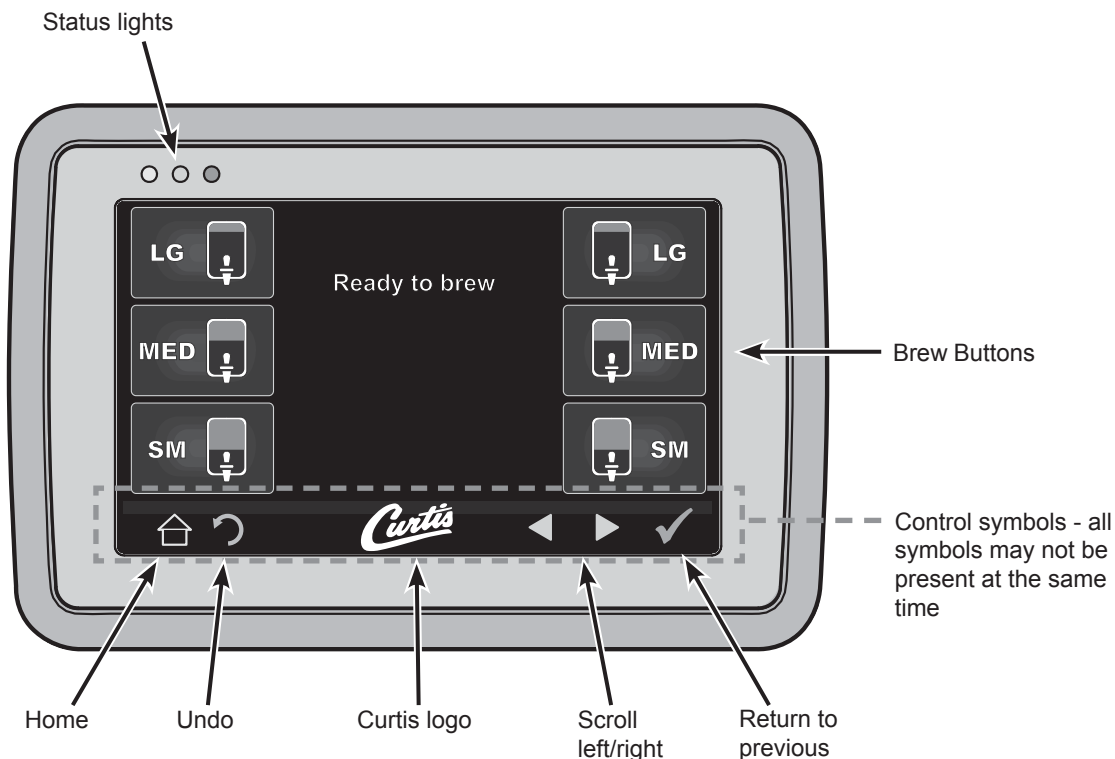

Entering Programming Mode

1 Tap the (white) Curtis logo on the touchscreen five (5) times to enter programming mode (see diagram above).

ENTER ACCESS CODE		
1234		
1	2	3
4	5	6
7	8	9
Del	0	OK

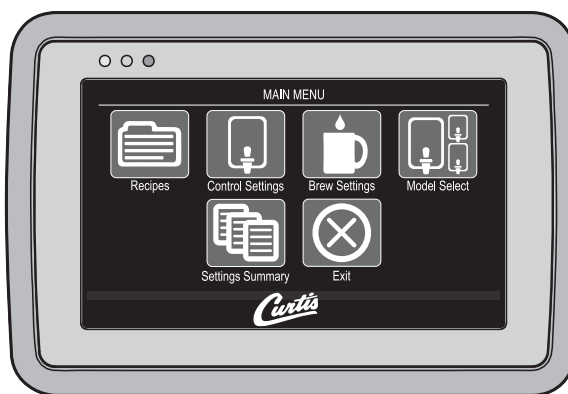

2 The ACCESS CODE screen will appear. The default pass code is 1 2 3 4. Once the code is entered, press OK. The MAIN MENU screen will appear. The access code can be reset in the Control Settings sub-menu, under Passwords.

3 The MAIN MENU screen contains a series of sub-menu icons. The icons vary based on the model selected under the Model Select sub-menu. For the brewer to operate properly, the model selected must match the model series on the brewer model number label affixed to the outside of the machine.

Programming

Shown below are the various programming options available in the programming MAIN MENU. The icons that appear vary based on the brewer model selected under Model Select.

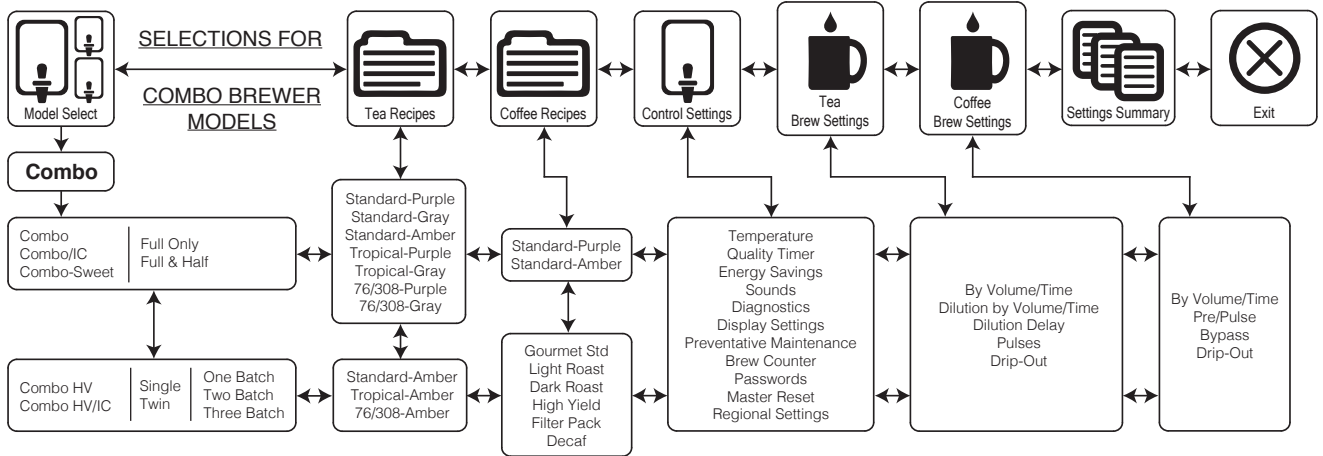
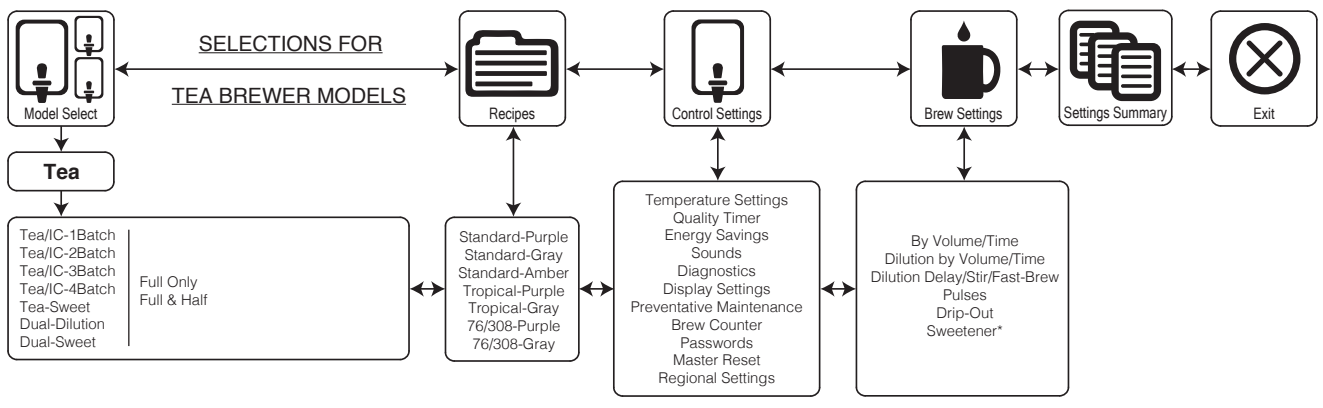
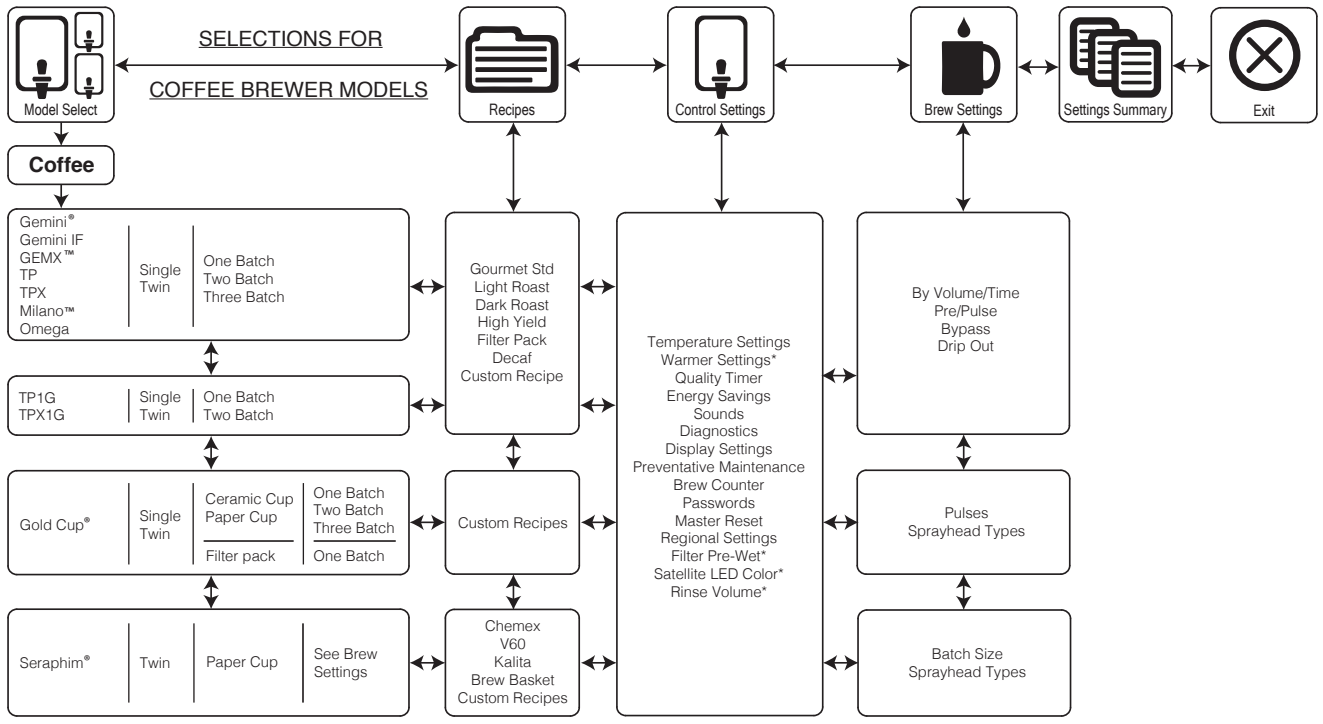

* Feature not available on some models

USB - Easy Programming

There are two methods for changing the default settings on G4 brewers. The settings can be programmed manually using the brewer touch screen, or automatically using the USB (Universal Serial Bus) data port on the side of the brewer. Using the USB connection and a flash drive easily reprograms the settings by simply copying data.

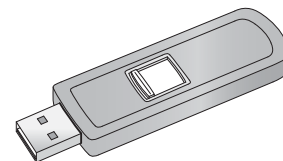

A flash drive can copy all of the settings from one identical G4 brewer to another. Doing so eliminates the need to program each step individually using the touchscreen. This process also makes it easy to quickly standardize the program settings on multiple G4 brewers.

Use a flash drive that supports USB 2.0 or above and has a type-A USB connection. The storage capacity must be 2 GB minimum.

i **IMPORTANT:** The flash drive must be completely blank. Erase any existing files on the drive before starting the following process.

Uploading the Software to the Flash Drive

- 1 Make sure the brewer is on. Check to make sure that the brewer you are copying settings from is programmed as desired.
- 2 Open the cover on the USB port and insert the connector on the empty flash drive. The port is located on the right side panel of the brewer, near the top. The universal control module (UCM) will upload all of the setup data onto the flash drive. The yellow LED icon on the top left of the touchscreen will light indicating that data is transferring. This process will only take a second to complete.

Downloading the Software to the Brewer from the Flash Drive

- 1 Select the (identical) brewer you wish to make program changes to. The brewer must be on.
- 2 Plug the loaded flash drive into the USB port on the brewer. The data copied from the first brewer will automatically download, overwriting all the settings that were on the second brewer.
- 3 The red LED on the top left of the touchscreen will indicate that the download is in process. This will only take a second.
- 4 Once the download is complete, the UCM will reboot so that the changes take effect.
- 5 Remove the flash drive. The download is complete. The data on the flash drive can continue to be downloaded into as many identical brewers as needed.

USB File Transfer

This screen will be present whenever the USB flash drive is inserted, provided the brewer is not currently brewing.

The default action is "No Action". The UCM will always create a backup on the flash drive before downloading settings/recipes or a screen-saver.

If a firmware update is present on the flash drive, the firmware update procedure will be started before the screen is shown.

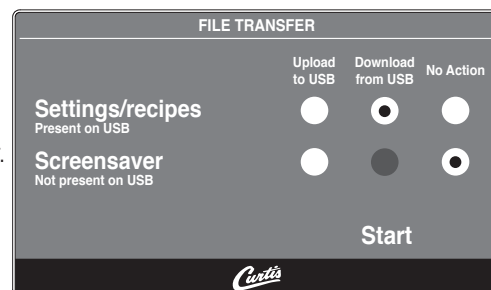

Omega - Single Coffee Brewer

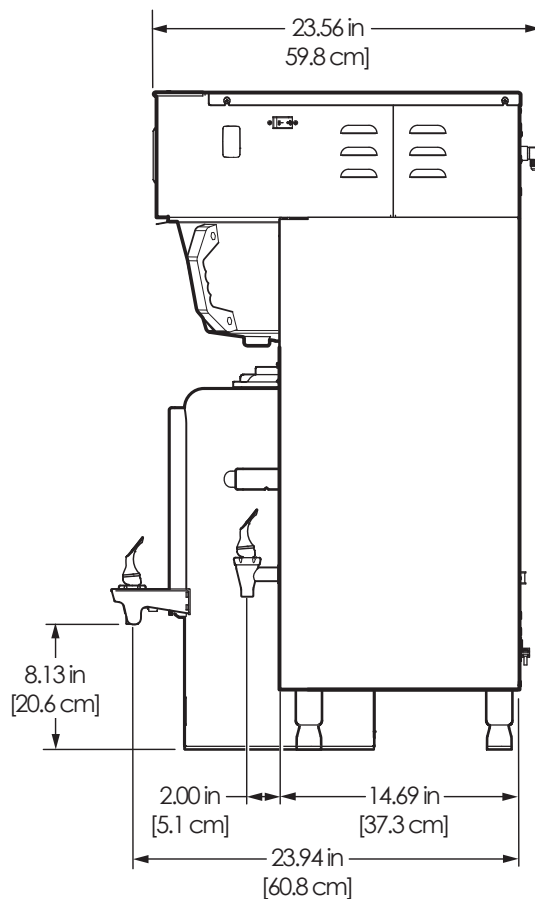
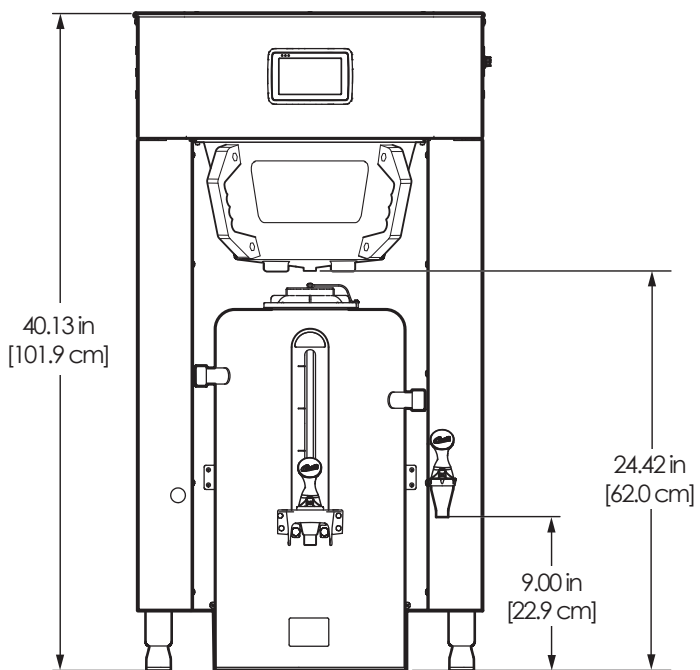
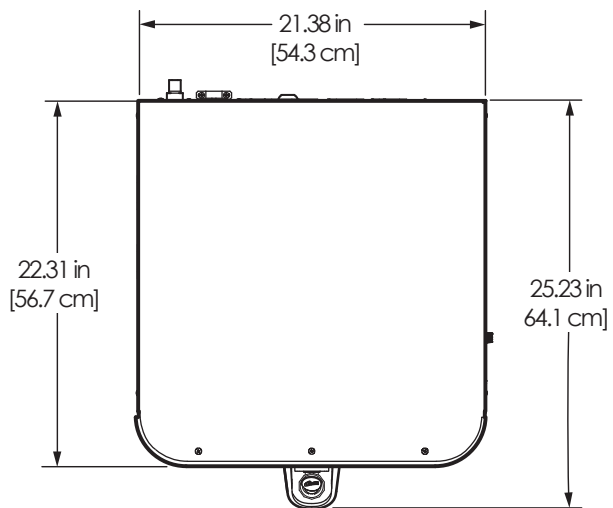

Omega - Twin Coffee Brewer

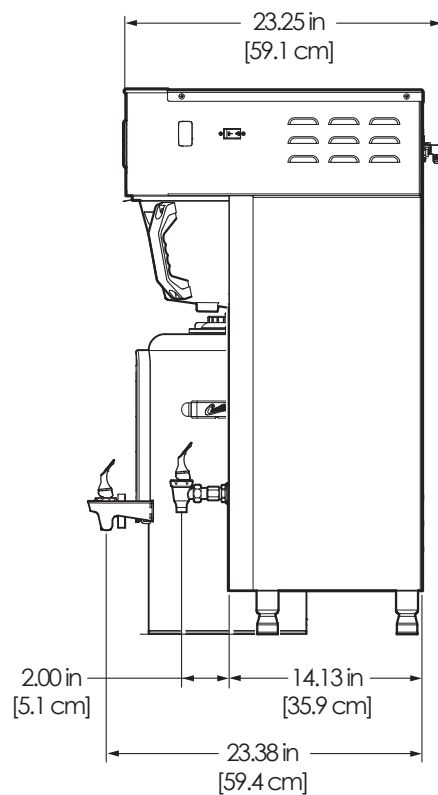
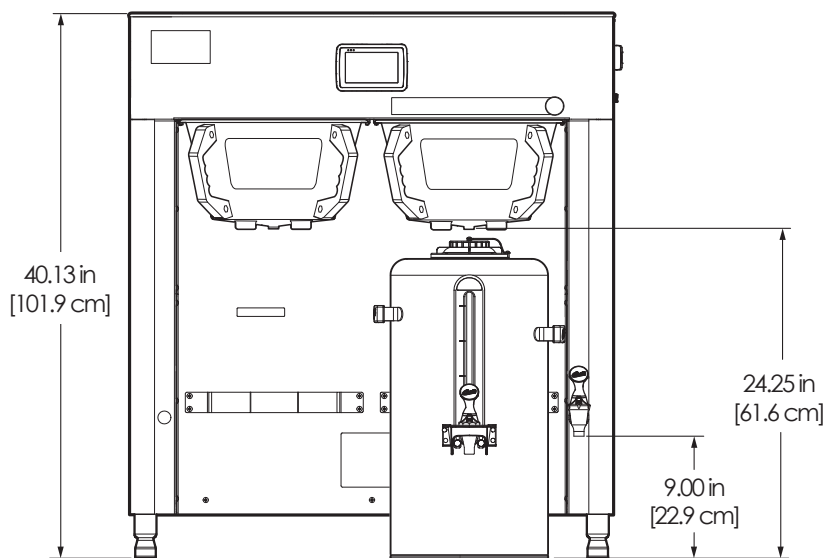
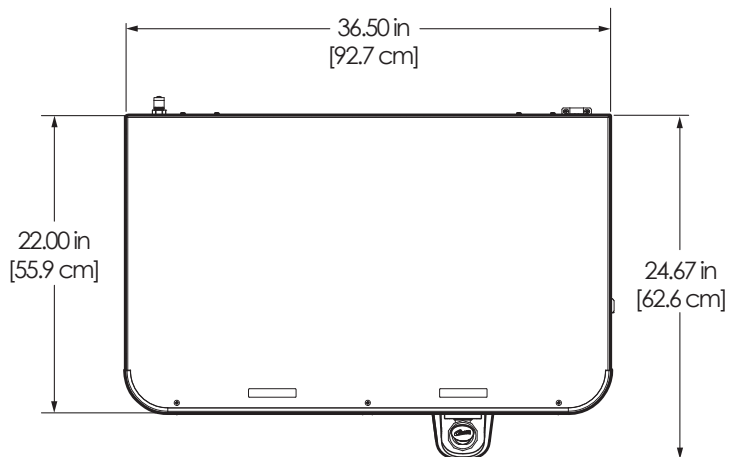



CAB-1 - Cleaning Brush

OMGS[16] - Main Chassis - Exploded View

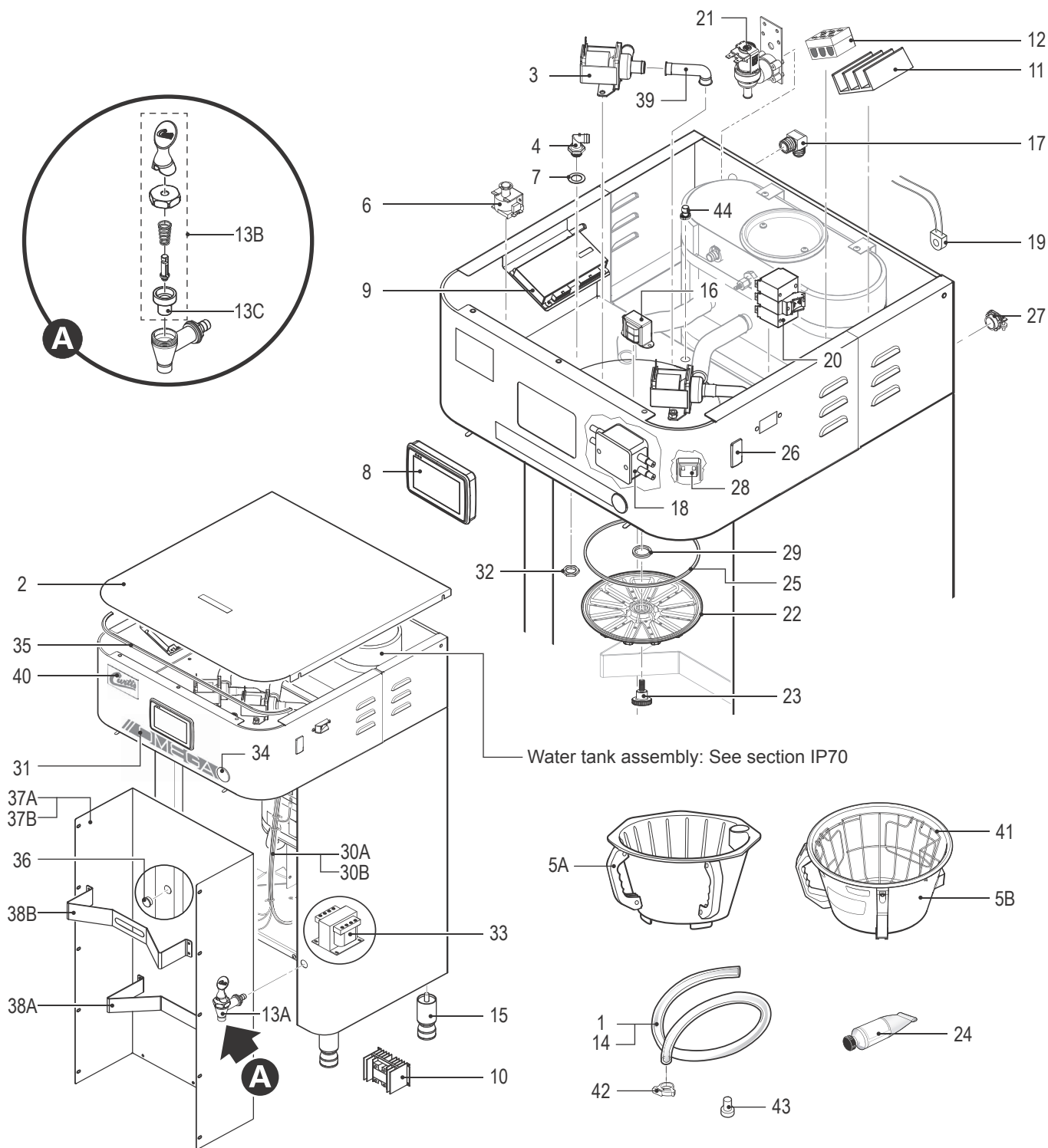

OMGS[16] - Main Chassis - Parts List

ITEM #	PART #	DESCRIPTION
1	WC-5350	TUBE, 1/2 ID x 1/8W SILICONE GEN USE
2	WC-62068	LID, TOP OMGS
3	WC-12012	VALVE, DUMP .50 DIA. 120VAC 50/60HZ OMGT/OMGS
4	WC-2977-02	FITTING, SPRAYHEAD PLASTIC
5A	WC-33004	BREW CONE ASSY NON-METAL OMGT/S
5B	WC-37593	KIT, BREW CONE ASSEMBLY W/WIRE BASKET OMGT/S (INCLUDES ITEM 41)
6	WC-442	SOLENOID, LOCK BREW CONE RIGHT/LEFT 120V TP2T/TP2S/GEMSS/GEM
7	WC-43089	GASKET, 1.000D X .625 I.D. X .030 THK WHITE EPDM 70 SHORE
8	WC-10000	CONTROL MODULE, TOUCH SCREEN G4
9	WC-10001	CONTROL MODULE, UPM 120/220V G4
10	WC-8559-102	RELAY, SOLID STATE 480V/50A (RELAY + HEATSINK)
11	WC-300	POWER BLOCK, 3 STA 175A 600V _k RU'S
12	WC-305	POWER BLOCK, 3 STA 85A 600V
13A	WC-1825	FAUCET, ASSY HOT WATER TP2S
13B	WC-3705HW	KIT, FAUCET S SERIES HOT WATER USE ON WC-1800HW
13C	WC-1805	SEAT CUP, "S" FAUCET USE ON WC-1800/B/LB/D/DL/L/WC-1803
14	WC-5310	TUBE, 5/16 ID x 1/8W SILICONE
15	WC-3528	LEG, 4" ADJUSTABLE 3/8-16 THRD ITALIAN STYLE
16	WC-589-101	TRANSFORMER, 120VAC-24V 4.8A W/ LEADS & MOLEX CONNECTOR
17	WC-2402P-P	ELBOW, 3/8"FL x 3/8" NPT PLATE
18	WC-588	NOISE, EMI FILTER 250VAC/20A
19	WC-14045-101	CURRENT SENSOR ASSY G4
20	WC-172	SWITCH, 50 AMP ROCKER STYLE OMGT/ OMGS
21	WC-12019	VALVE, INLET 4GPM 120V 9W BB/BH
22	WC-29086	SPRAYHEAD, PLASTIC 8 INCH DIAMETER OMGT/OMGS

¹ OMGS ² OMGS16

OMGS[16] - Recommended Parts to Stock

ITEM #	PART #	DESCRIPTION
1	WC-5350	TUBE, 1/2 ID x 1/8W SILICONE GEN USE
3	WC-12012	VALVE, DUMP .50 DIA. 120VAC 50/60HZ OMGT/OMGS
6	WC-442	SOLENOID, LOCK BREW CONE RIGHT/LEFT 120V TP2T/TP2S/GEMSS/GEM
9	WC-10001	CONTROL MODULE, UPM 120/220V G4

ITEM #	PART #	DESCRIPTION
23	WC-4549	SCREW, 3/8-16 X .787 KNURLED THUMB, SST. OMEGA
24	WC-5231	COMPOUND, HEAT SINK 5OZ
25	WC-43141	O-RING, 7.484" ID X .139" CS OMGT/ OMGS
26	WC-10008	UNIVERSAL HOST ADAPTER USB
27	WC-1515	CORD GRIP, 1" OMGT/ OMGS
28	WC-1516 ^{1,2,3}	BREAKER, CIRCUIT 2-POLE 20A/ 250VAC
29	WC-43140	O-RING, 1" I.D. X 1/8" THICK OMGT/ OMGS
30A	WC-13991 ¹	HARNESS, ASSY OMGS
30B	WC-13991-101 ²	HARNESS, ASSY OMGS16
31	WC-39982	LABEL, FRONT WRAP OMEGA
32	WC-4212-02	NUT, 5/8-18 JAM PLASTIC
33	WC-594-101 ²	TRANSFORMER, 250VA, 208-575VAC TO 24/115, 230VAC
34	WC-39805	LABEL, GOLD CUP NAMEPLATE
35	WC-53115	TRIM, EDGE VINYL 7/16"-1/32" X33/64 WITH METAL CORE TCO/TC (ORDER 4 FEET)
36	WC-14017	PLUG, DOME 0.75"DIA HOLE BLACK PLASTIC NYLON 6/6 FOR OMGT
37A	WC-62069-102	COVER ASSY, FRONT NON- METAL BREW CONE OMGS
37B	WC-62069-101	COVER ASSY, FRONT NON-ROTATE OPTION ONLY (NON-ROTATE OPTION ONLY)
38A	WC-61819	BRACKET, SERVER STOP OMGT
38B	WC-61819-101	BRACKET, BREWCONE NOT ROTATE
39	WC-2471	ELBOW, SILICONE OMEGA
40	WC-390092	LABEL, FRONT OMEGA CURTIS LOGO
41	WC-3394	BREW BASKET, WIRE ASSEMBLY OMGT/OMGS
42	WC-43059	CLAMP, HOSE SNAP NYLON .616/.707
43	WC-43058	PLUG, TANK DRAIN PLASTIC
44	WC-29044-101	SLEEVE, OVERFLOW ASSY

OMGT[10/16/30] - Main Chassis - Exploded View

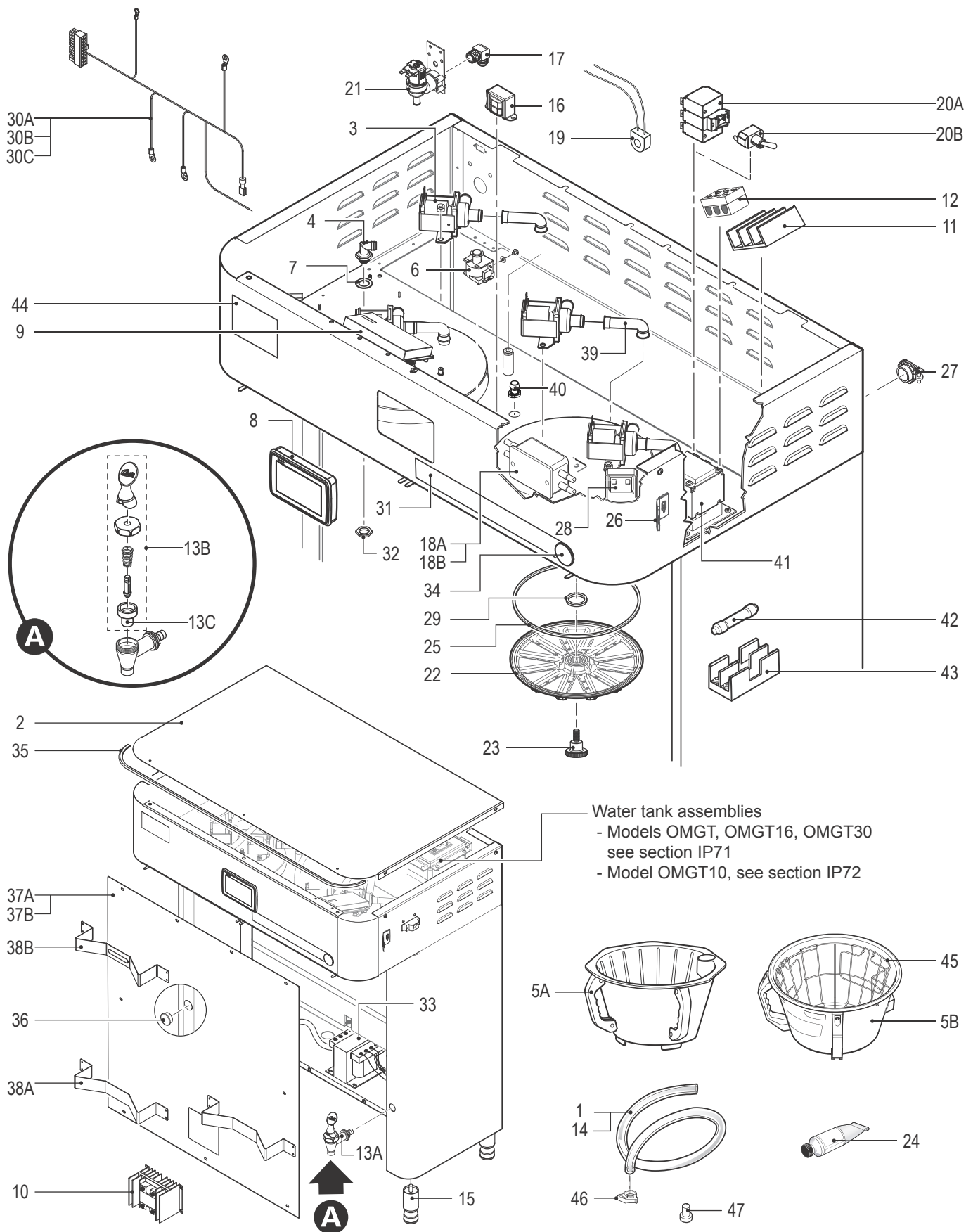

OMGT[10/16/30] - Main Chassis - Parts List

ITEM #	PART #	DESCRIPTION
1	WC-5350	TUBE, 1/2 ID x 1/8W SILICONE GEN USE
2	WC-61912	LID, ASSY OMTG
3	WC-12012	VALVE, DUMP .50 DIA. 120VAC 50/60HZ OMTG/OMGS
4	WC-2977-02	FITTING, SPRAYHEAD PLASTIC
5A	WC-33004	BREW CONE ASSY NON-METAL OMTG/S
5B	WC-37593	KIT, BREW CONE ASSEMBLY W/WIRE BASKET OMTG/S (INCLUDES ITEM 45)
6	WC-442	SOLENOID, LOCK BREW CONE RIGHT/LEFT 120V TP2T/TP2S/GEMSS/GEM
7	WC-43089	GASKET, 1.000D X .625 I.D. X .030 THK WHITE EPDM 70 SHORE
8	WC-10000	CONTROL MODULE, TOUCH SCREEN G4
9	WC-10001	CONTROL MODULE, UPM 120/220V G4
10	WC-8559-102	RELAY, SOLID STATE 480V/50A (RELAY + HEATSINK)
11	WC-300	POWER BLOCK, 3 STA 175A 600V RU'S
12	WC-305	POWER BLOCK, 3 STA 85A 600V
13A	WC-1825	FAUCET, ASSY HOT WATER TP2S
13B	WC-3705HW	KIT, FAUCET S SERIES HOT WATER USE ON WC-1800HW
13C	WC-1805	SEAT CUP, "S" FAUCET USE ON WC-1800/B/LB/D/DL/L/WC-1803
14	WC-5310	TUBE, 5/16 ID x 1/8W SILICONE
15	WC-3528	LEG, 4" ADJUSTABLE 3/8-16 THRD ITALIAN STYLE
16	WC-589-101	TRANSFORMER, 120VAC-24V 4.8A W/ LEADS & MOLEX CONNECTOR
17	WC-2402P-P	KIT, ELBOW 3/8 NPT X 3/8 FLARE PLATED
18A	WC-588 ^{1,2,3}	NOISE, EMI FILTER 250VAC/20A
18B	WC-597 ⁴	FILTER, NOISE EMI 480V/20A 3PH
19	WC-14045-101	CURRENT SENSOR ASSY G4
20A	WC-172 ^{1,2,3}	SWITCH, 50 AMP ROCKER STYLE OMTG/OMGS
20B	WC-102 ⁴	SWITCH, TOGGLE NON-LIT SPST 15A 125/6A 250VAC RESISTIVE
21	WC-12019	VALVE, INLET 4GPM 120V 9W BB/BH
22	WC-29086	SPRAYHEAD, PLASTIC 8 INCH DIAMETER OMTG/OMGS

¹ OMTG ² OMTG10 ³ OMTG16 ⁴ OMTG30

OMGT[10/16/30] - Recommended Parts to Stock

ITEM #	PART #	DESCRIPTION
1	WC-5350	TUBE, 1/2 ID x 1/8W SILICONE GEN USE
3	WC-12012	VALVE, DUMP .50 DIA. 120VAC 50/60HZ OMTG/OMGS
6	WC-442	SOLENOID, LOCK BREW CONE RIGHT/LEFT 120V TP2T/TP2S/GEMSS/GEM
9	WC-10001	CONTROL MODULE, UPM 120/220V G4

ITEM #	PART #	DESCRIPTION
23	WC-4549	SCREW, 3/8-16 X .787 KNURLED THUMB, SST. OMEGA
24	WC-5231	COMPOUND, HEAT SINK 5OZ
25	WC-43141	O-RING, 7.484" ID X .139" CS OMTG/OMGS
26	WC-10008	UNIVERSAL HOST ADAPTER USB
27	WC-1515	CORD GRIP, 1" OMTG/OMGS
28	WC-1516 ^{1,2,3}	BREAKER, CIRCUIT 2-POLE 20A/ 250VAC
29	WC-43140	O-RING, 1" I.D. X 1/8" THICK OMTG/OMGS
30A	WC-13464 ^{1,2}	HARNESS, ASSY OMTG
30B	WC-13464-101 ³	HARNESS, ASSY OMTG16
30C	WC-13464-102 ⁴	HARNESS, ASSY OMTG30
31	WC-39982	LABEL, FRONT WRAP OMEGA
32	WC-4212-02	NUT, 5/8-18 JAM PLASTIC
33	WC-594-101 ^{3,4}	TRANSFORMER, 250VA, 208-575VAC TO 24/115, 230VAC
34	WC-39805	LABEL, GOLD CUP NAMEPLATE
35	WC-53115	TRIM, EDGE VINYL 7/16"-1/32" X33/64 WITH METAL CORE TCO/TC (ORDER 4 FEET)
36	WC-14017	PLUG, DOME 0.75"DIA HOLE BLACK PLASTIC NYLON 6/6 FOR OMTG
37A	WC-61818-103	FRONT COVER ASSY, FOR NON-METAL BREW CONE OMTG
37B	WC-61818-101	FRONT COVER ASSY, OMTG (NON-ROTATE OPTION ONLY)
38A	WC-61819	BRACKET, SERVER STOP OMTG
38B	WC-61819-101	BRACKET, BREWCONE NOT ROTATE
39	WC-2471	ELBOW, SILICONE OMEGA
40	WC-29044-101	SLEEVE, OVERFLOW ASSY
41	WC-431 ⁴	CONTACTOR, 120V 60A 3P DP
42	WC-1520 ⁴	FUSE, TIME DELAY CLASS CC 3.5A/600VAC
43	WC-1521 ⁴	FUSE HOLDER, CLASS CC 30A 2P FOR WC-1520
44	WC-390092	LABEL, FRONT OMEGA CURTIS LOGO
45	WC-3394	BREW BASKET, WIRE ASSEMBLY OMTG/OMGS
46	WC-43059	CLAMP, HOSE SNAP NYLON .616/.707
47	WC-43058	PLUG, TANK DRAIN PLASTIC

WC-62091 - Tank Assembly

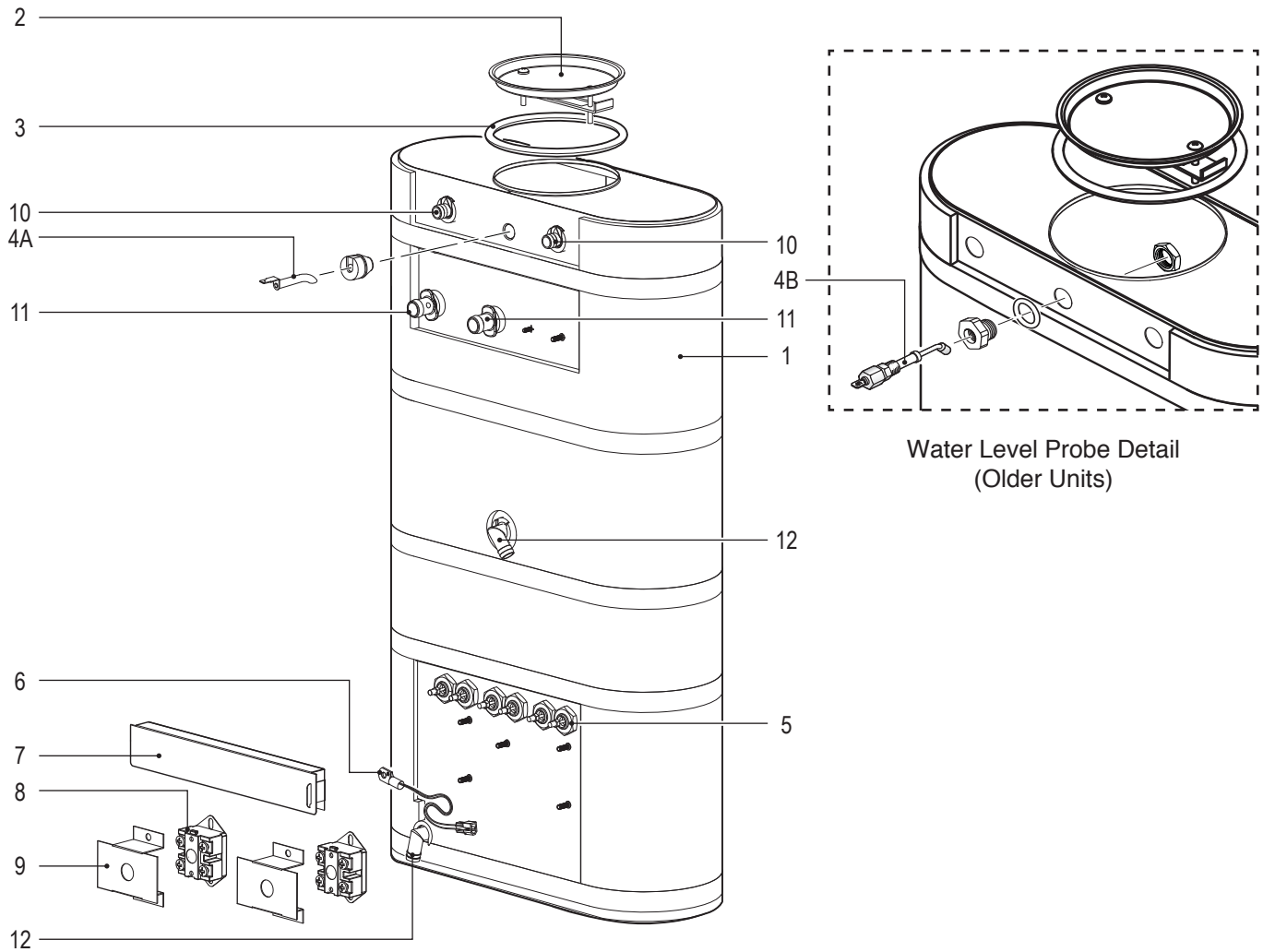

WC-62091 - Tank Assembly - Parts List

ITEM #	PART #	DESCRIPTION
1	WC-62091	TANK, COMPLETE 7.5KW 220VAC OMGS
2	WC-37008	KIT, TANK LID ROUND (INCLUDES O-RING)
3	WC-43067*	O-RING, 4-1/2" I.D. X Ø.285 SILICONE TANK LID
4A ¹	WC-5528K*	KIT, WATER LEVEL PROBE, SILICONE
4B ²	WC-5502-01*	KIT, PROBE, ASSY WATER LEVEL W/HEX FITTING, O-RING & NUT
5	WC-934-101*	ELEMENT, HEATING 2.5KW 220V
6	WC-1438-101*	SENSOR, TEMPERATURE TANK
7	WC-4382*	GUARD, SHOCK HTNG ELMNT DOUBLE

ITEM #	PART #	DESCRIPTION
8	WC-522*	THERMOSTAT, HI LIMIT HEATER CONTROL DPST 277V 40A
9	WC-43055*	GUARD, SHOCK RESET THERMOSTAT (WC-522)
10	WC-37266*	KIT, FITTING TANK OVERFLOW
11	WC-37357*	KIT, STRAIGHT PLASTIC FITTING AND BUSHING 12MM
12	WC-37365*	KIT, FITTING TANK INLET

¹ Units built 01/04/2019 and later.

² Units built before 01/04/2019.Replaces WC-5527.

* Recommended parts to stock.

WC-54328 - Tank Assembly

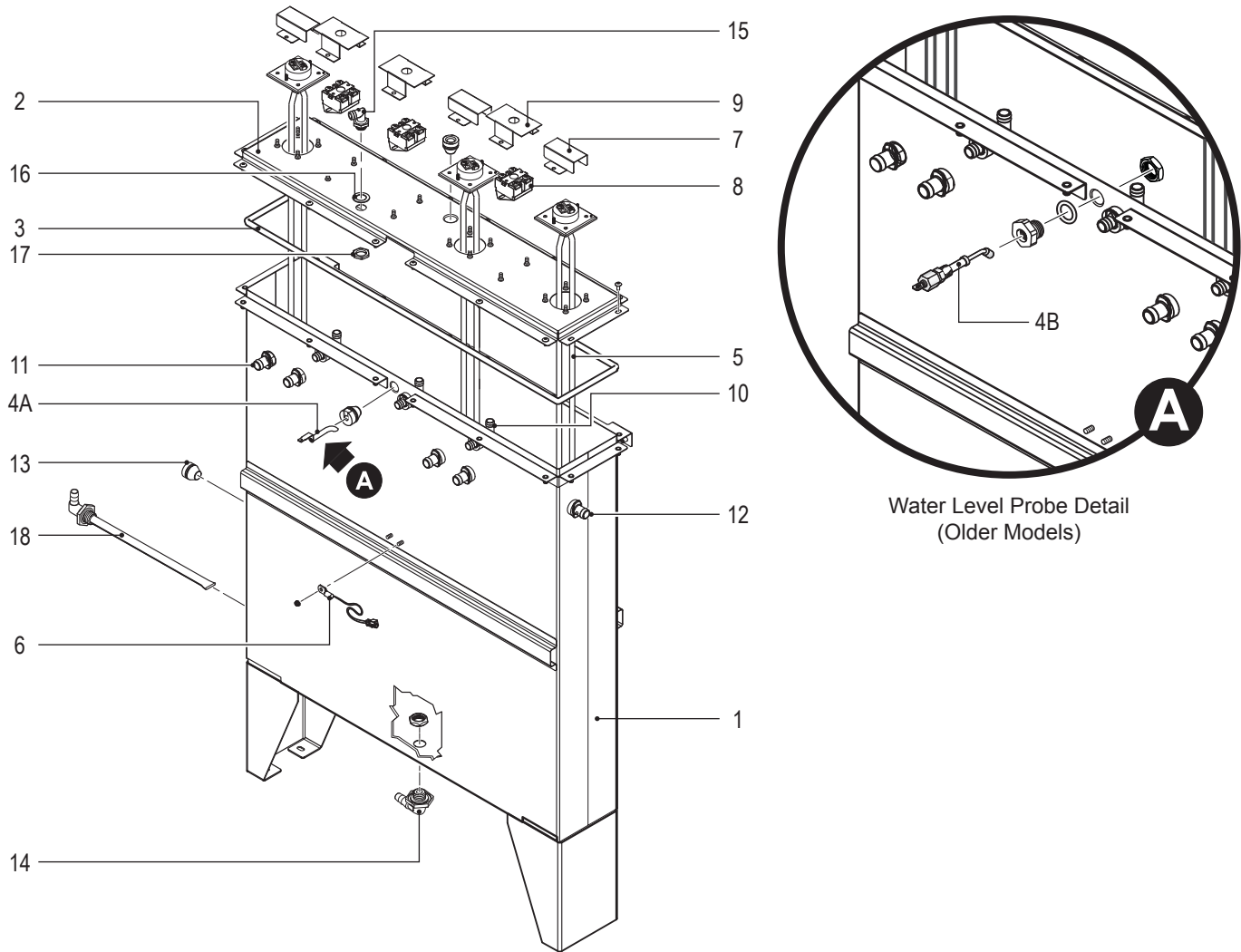

WC-54328 - Tank Assembly - Parts List

ITEM #	PART #	DESCRIPTION
1	WC-54328	TANK, COMPLETE 208V 12KW OMGT
2	WC-61832	LID, TANK ASSY OMGT
3	WC-43142*	GASKET, TANK LID OMGT
4A ¹	WC-5528K*	KIT, WATER LEVEL PROBE, SILICONE
4B ²	WC-5502-01*	KIT, PROBE, ASSY WATER LEVEL W/HEX FITTING, O-RING & NUT
5	WC-979-101	ELEMENT, HEATING 4000W 208V VERTICAL OMGT
6	WC-1438-101*	SENSOR, TEMPERATURE TANK
7	WC-43149*	GUARD, HEATING ELEMENT (FOR WC- 979) OMGT/OMGS
8	WC-522*	THERMOSTAT, HI LIMIT HEATER CONTROL DPST 277V 40A
9	WC-43055*	GUARD, SHOCK RESET THERMOSTAT (WC-522)

ITEM #	PART #	DESCRIPTION
10	WC-37266*	KIT, FITTING TANK OVERFLOW
11	WC-37357*	KIT, STRAIGHT PLASTIC FITTING AND BUSHING 12MM
12	WC-37317*	KIT, STRAIGHT FITTING & BUSHING 8mm GEN USE
13	WC-2630*	BUSHING, CONICAL BLIND GEN USE
14	WC-37780	KIT, FITTING INLET ENLARGED HEX
15	WC-2977-02	FITTING, SPRAYHEAD PLASTIC
16	WC-43089	GASKET, 1.00OD X .625 I.D. X .030 THK WHITE EPDM 70 SHORE
17	WC-4212-02	NUT, 5/8-18 JAM PLASTIC
18	WC-37780-101	TUBE, INLET MANIFOLD ASSY

¹ Units built 01/04/2019 and later.

² Units built before 01/04/2019. Replaces WC-5527.

* Recommended parts to stock.

WC-54328-102 - Tank Assembly

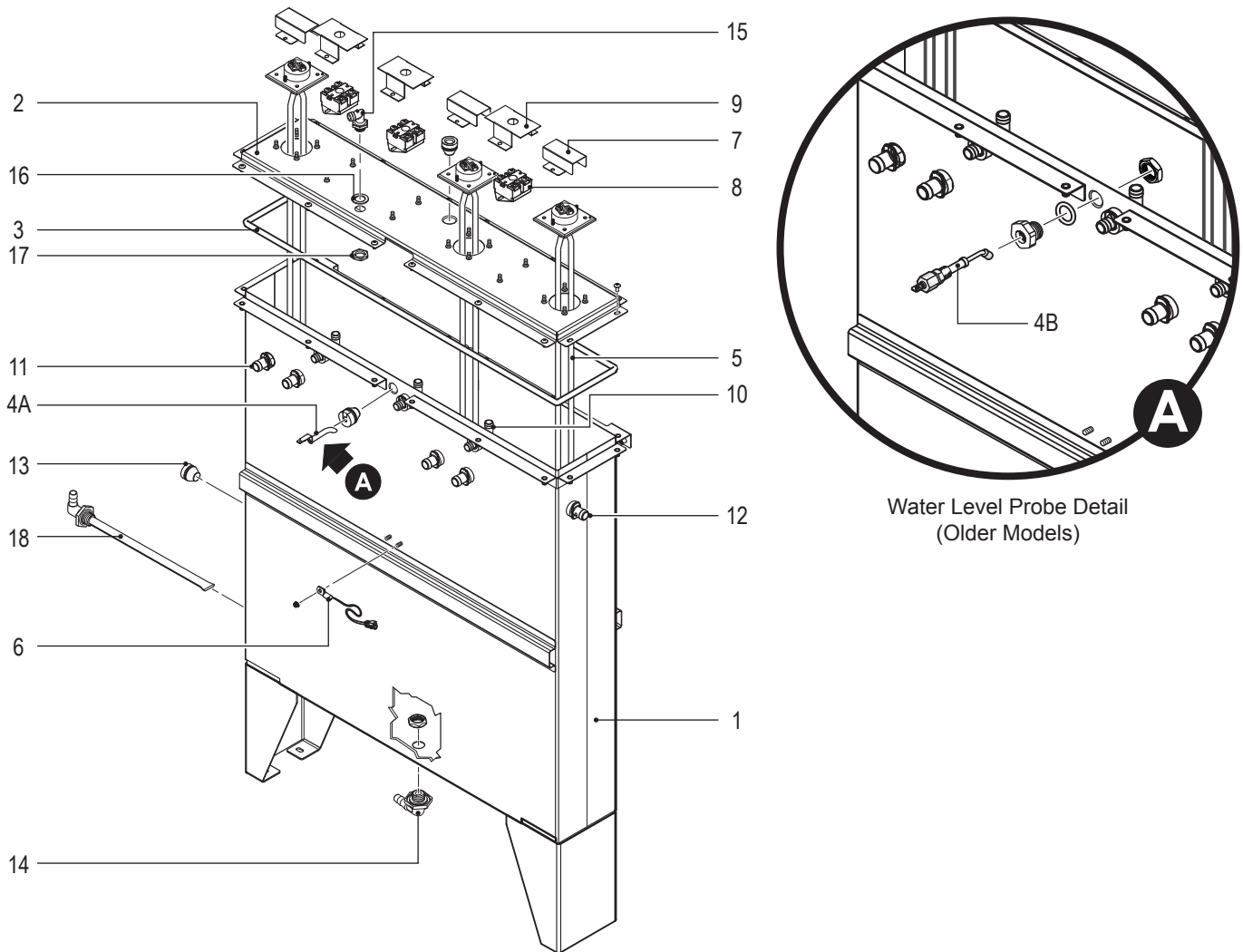

WC-54328-102 - Tank Assembly - Parts List

ITEM #	PART #	DESCRIPTION
1	WC-54328	TANK, COMPLETE 208V 12KW OMGT
2	WC-61832	LID, TANK ASSY OMGT
3	WC-43142	GASKET, TANK LID OMGT
4A ¹	WC-5528K*	KIT, WATER LEVEL PROBE, SILICONE
4B ²	WC-5502-01*	KIT, PROBE, ASSY WATER LEVEL W/HEX FITTING, O-RING & NUT
5	WC-979	ELEMENT, HEATING 4000W 240V VERTICAL OMGT
6	WC-1438-101*	SENSOR, TEMPERATURE TANK
7	WC-43149	GUARD, HEATING ELEMENT (FOR WC- 979) OMGT/OMGS
8	WC-522*	THERMOSTAT, HI LIMIT HEATER CONTROL DPST 277V 40A
9	WC-43055*	GUARD, SHOCK RESET THERMOSTAT (WC-522)

ITEM #	PART #	DESCRIPTION
10	WC-37266*	KIT, FITTING TANK OVERFLOW
11	WC-37357*	KIT, STRAIGHT PLASTIC FITTING AND BUSHING 12MM
12	WC-37317*	KIT, STRAIGHT FITTING & BUSHING 8mm GEN USE
13	WC-2630*	BUSHING, CONICAL BLIND GEN USE
14	WC-37780	KIT, FITTING INLET ENLARGED HEX
15	WC-2977-02	FITTING, SPRAYHEAD PLASTIC
16	WC-43089	GASKET, 1.00OD X .625 I.D. X .030 THK WHITE EPDM 70 SHORE
17	WC-4212-02	NUT, 5/8-18 JAM PLASTIC
18	WC-37780-101	TUBE, INLET MANIFOLD ASSY

¹ Units built 01/04/2019 and later.

² Units built before 01/04/2019. Replaces WC-5527.

* Recommended parts to stock.

OMGS

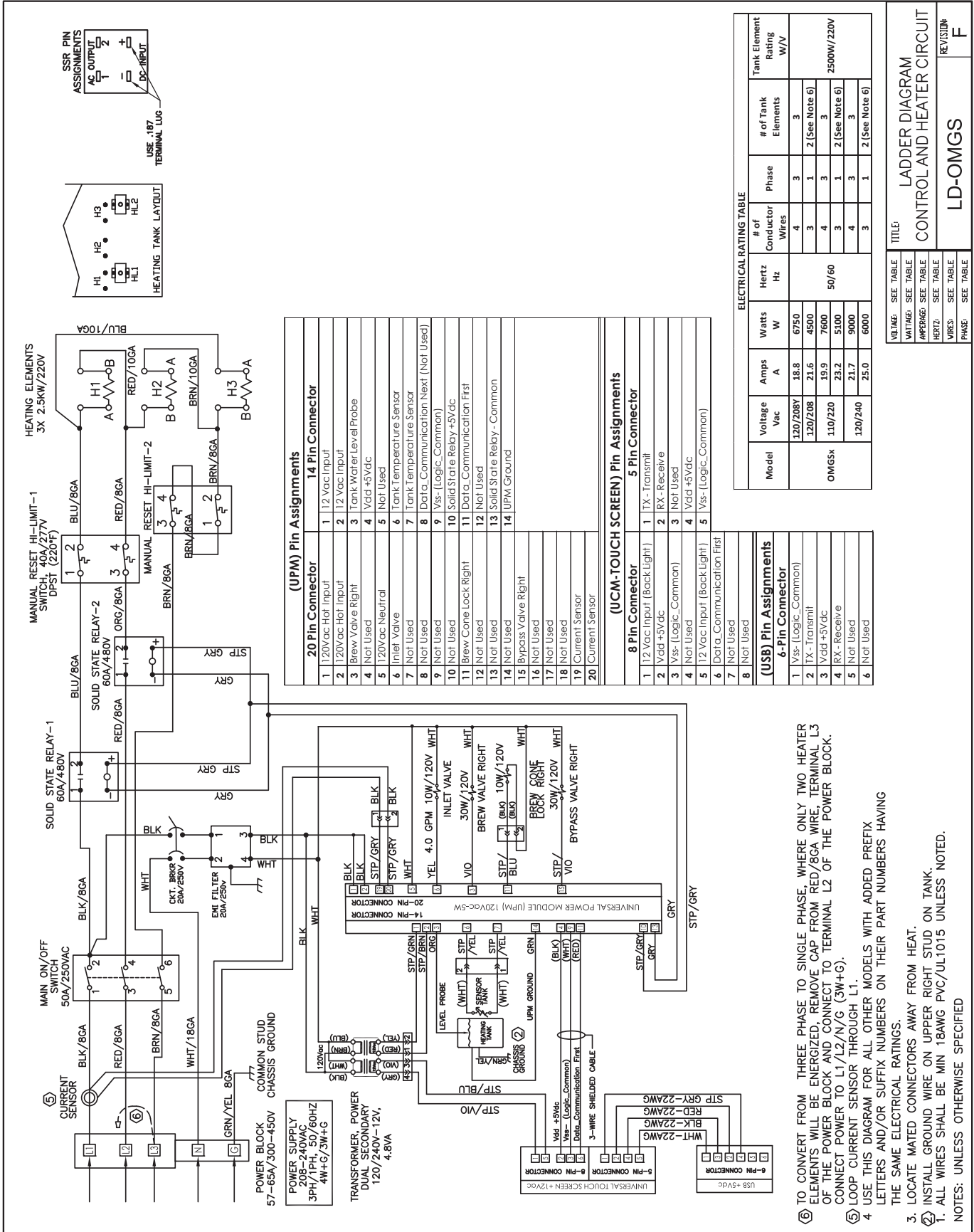

(UPM) Pin Assignments

20 Pin Connector	14 Pin Connector
1 120Vac Hot Input	1 12 Vac Input
2 120Vac Hot Input	2 12 Vac Input
3 Brew Valve Right	3 Tank Water Level Probe
4 Not Used	4 Vdd +5Vdc
5 120Vac Neutral	5 Not Used
6 Inlet Valve	6 Tank Temperature Sensor
7 Not Used	7 Tank Temperature Sensor
8 Not Used	8 Data, Communication Next (Not Used)
9 Not Used	9 Vss (Logic, Common)
10 Not Used	10 Solid State Relay +5Vdc
11 Brew Come Lock Right	11 Data, Communication First
12 Not Used	12 Not Used
13 Not Used	13 Solid State Relay - Common
14 Not Used	14 UPM Ground
15 Bypass Valve Right	
16 Not Used	
17 Not Used	
18 Not Used	
19 Current Sensor	
20 Current Sensor	

(UCM-TOUCH SCREEN) Pin Assignments

8 Pin Connector	5 Pin Connector
1 12 Vac Input (Back Light)	1 TX - Transmit
2 Vdd +5Vdc	2 RX - Receive
3 Vss (Logic, Common)	3 Not Used
4 Not Used	4 Vdd +5Vdc
5 12 Vac Input (Back Light)	5 Vss (Logic, Common)
6 Data, Communication First	
7 Not Used	
8 Not Used	

ELECTRICAL RATING TABLE

Model	Voltage Vac	Amps A	Watts W	Hertz Hz	# of Conductor Wires	Phase	# of Tank Elements	Tank Element Rating W/V
	120/208Y	18.8	6750		4	3	3	
	120/208	21.6	4500		3	1	2 (See Note 6)	
	110/220	19.9	7600	50/60	4	3	3	
	120/240	23.2	5100		3	1	2 (See Note 6)	2500W/220V
	120/240	21.7	9000		4	3	3	
	120/240	25.0	6000		3	1	2 (See Note 6)	

TITLE
LADDER DIAGRAM
CONTROL AND HEATER CIRCUIT

REVISION
LD-OMGS
F

- ⑥ TO CONVERT FROM THREE PHASE TO SINGLE PHASE, WHERE ONLY TWO HEATER ELEMENTS WILL BE ENERGIZED, REMOVE CAP FROM RED/8GA WIRE, TERMINAL L3 OF THE POWER BLOCK AND CONNECT TO TERMINAL L2 OF THE POWER BLOCK. CONNECT POWER TO L1/L2/N/G (3W+G).
 - ⑦ LOOP CURRENT SENSOR THROUGH L1.
 - ⑧ USE THIS DIAGRAM FOR ALL OTHER MODELS WITH ADDED PREFIX LETTERS AND/OR SUFFIX NUMBERS ON THEIR PART NUMBERS HAVING THE SAME ELECTRICAL RATINGS.
 - ⑨ LOCATE MATED CONNECTORS AWAY FROM HEAT.
 - ⑩ INSTALL GROUND WIRE ON UPPER RIGHT STUD ON TANK.
 - ⑪ ALL WIRES SHALL BE MIN 18AWG PVC/JUL1015 UNLESS NOTED.
- NOTES: UNLESS OTHERWISE SPECIFIED

OMGS16

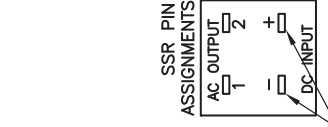
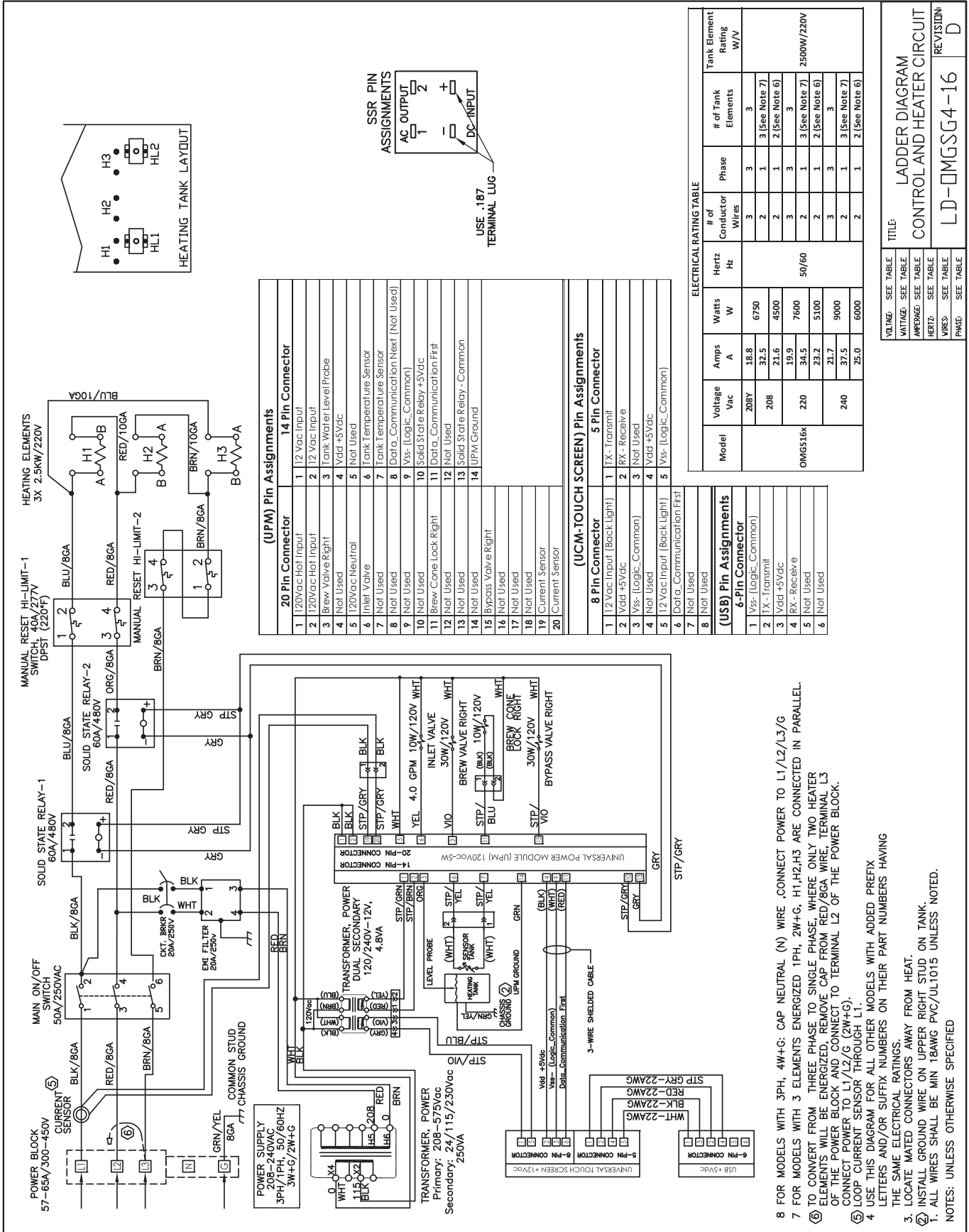

(UPM) Pin Assignments

20 Pin Connector		14 Pin Connector	
1	120Vac Hot Input	1	12 Vac Input
2	120Vac Hot Input	2	12 Vac Input
3	Brew Valve Right	3	Tank Water Level Probe
4	Not Used	4	Vdd +5Vdc
5	120Vac Neutral	5	Not Used
6	Inlet Valve	6	Tank Temperature Sensor
7	Not Used	7	Tank Temperature Sensor
8	Not Used	8	Data Communication Next (Not Used)
9	Not Used	9	Vss-(Logic, Common)
10	Not Used	10	Solid State Relay +5Vdc
11	Brew Come Lock Right	11	Data Communication First
12	Not Used	12	Not Used
13	Not Used	13	Solid State Relay - Common
14	Not Used	14	UPM Ground
15	Bypass Valve Right		
16	Not Used		
17	Not Used		
18	Not Used		
19	Current Sensor		
20	Current Sensor		

(UCM-TOUCH SCREEN) Pin Assignments

8 Pin Connector		5 Pin Connector	
1	12 Vac Input (Back Light)	1	TX - Transmit
2	Vdd +5Vdc	2	RX - Receive
3	Vss-(Logic, Common)	3	Not Used
4	Not Used	4	Vdd +5Vdc
5	12 Vac Input (Back Light)	5	Vss-(Logic, Common)
6	Data Communication First		
7	Not Used		
8	Not Used		

ELECTRICAL RATING TABLE

Model	Voltage Vac	Amperes A	Watts W	Hertz Hz	# of Conductor Wires	Phase	# of Tank Elements	Tank Element Rating W/V
OMGS16	208Y	18.8	6750	50/60	3	3	3	2500W/220V
	208	32.5	4500		2	1	2 (See Note 6)	
	220	34.5	7600		3	3	3 (See Note 7)	
OMGS16	220	34.5	5100	50/60	2	1	2 (See Note 6)	2500W/220V
	231.2	21.7	9000		3	3	3 (See Note 7)	
	240	25.0	6000		2	1	2 (See Note 6)	

(USB) Pin Assignments

6-Pin Connector	
1	Vss-(Logic, Common)
2	TX - Transmit
3	Vdd +5Vdc
4	RX - Receive
5	Not Used
6	Not Used

- 8 FOR MODELS WITH 3PH, 4W+G: CAP NEUTRAL (N) WIRE, CONNECT POWER TO L1/L2/L3/G
 - 7 FOR MODELS WITH 3 ELEMENTS ENERGIZED 1PH, 2W+G, H1,H2,H3 ARE CONNECTED IN PARALLEL.
 - 6 TO CONVERT FROM THREE PHASE TO SINGLE PHASE, WHERE ONLY TWO HEATER ELEMENTS WILL BE ENERGIZED, REMOVE CAP FROM RED/8GA WIRE, TERMINAL L3 OF THE POWER BLOCK AND CONNECT TO TERMINAL L2 OF THE POWER BLOCK.
 - 5 CONNECT POWER TO L1/L2/G (2W+G).
 - 4 LOOP CURRENT SENSOR THROUGH L1.
 - 3 USE THIS DIAGRAM FOR ALL OTHER MODELS WITH ADDED PREFIX LETTERS AND/OR SUFFIX NUMBERS ON THEIR PART NUMBERS HAVING THE SAME ELECTRICAL RATINGS.
 - 2 INSTALL GROUND WIRE ON UPPER RIGHT STUD ON TANK.
 - 1 ALL WIRES SHALL BE MIN 18AWG PVC/UL1015 UNLESS NOTED.
- NOTES: UNLESS OTHERWISE SPECIFIED

TITLE

LADDER DIAGRAM
CONTROL AND HEATER CIRCUIT

REVISION

LD-OMGS16-16	D
--------------	---

OMGT

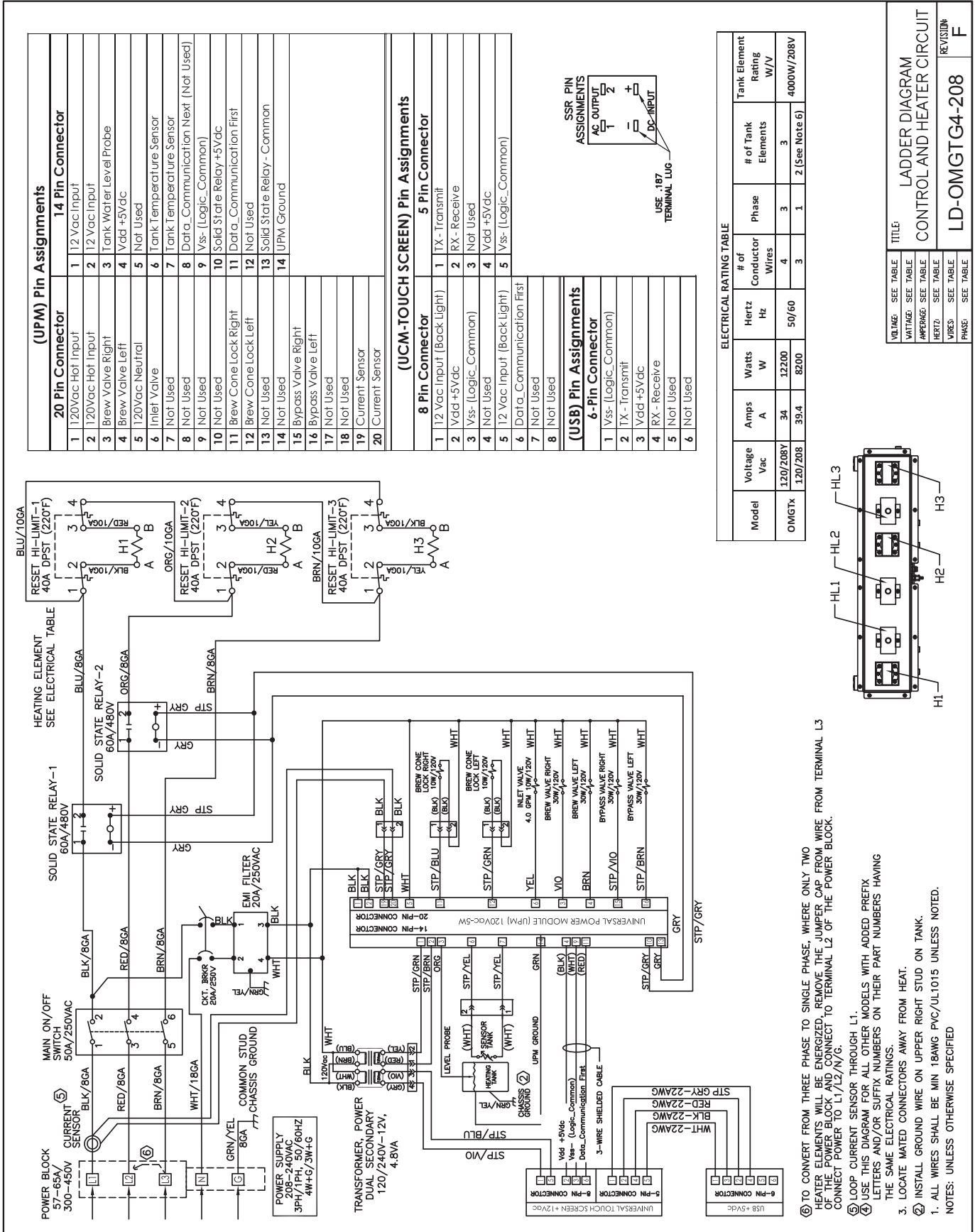

(UPM) Pin Assignments

20 Pin Connector		14 Pin Connector	
1	120Vac Hot Input	1	12 Vac Input
2	120Vac Hot Input	2	12 Vac Input
3	Brew Valve Right	3	Tank Water Level Probe
4	Brew Valve Left	4	Vdd +5Vdc
5	120Vac Neutral	5	Not Used
6	Inlet Valve	6	Tank Temperature Sensor
7	Not Used	7	Tank Temperature Sensor
8	Not Used	8	Data Communication Next (Not Used)
9	Not Used	9	Vss- (Logic Common)
10	Not Used	10	Solid State Relay +5Vdc
11	Brew Cone Lock Right	11	Data Communication First
12	Brew Cone Lock Left	12	Not Used
13	Not Used	13	Solid State Relay - Common
14	Not Used	14	UPM Ground
15	Bypass Valve Right		
16	Bypass Valve Left		
17	Not Used		
18	Not Used		
19	Current Sensor		
20	Current Sensor		

(UCM-TOUCH SCREEN) Pin Assignments

8 Pin Connector		5 Pin Connector	
1	12 Vac Input (Back Light)	1	TX - Transmit
2	Vdd +5Vdc	2	RX - Receive
3	Vss- (Logic Common)	3	Not Used
4	Not Used	4	Vdd +5Vdc
5	12 Vac Input (Back Light)	5	Vss- (Logic Common)
6	Data Communication First		
7	Not Used		
8	Not Used		



USE .187 TERMINAL LUG

(USB) Pin Assignments

6-Pin Connector	
1	Vss- (Logic Common)
2	TX - Transmit
3	Vdd +5Vdc
4	RX - Receive
5	Not Used
6	Not Used

ELECTRICAL RATING TABLE

Model	Voltage Vac	Amps A	Watts W	Hertz Hz	# of Conductor Wires	Phase	# of Tank Elements	Tank Element Rating W/V
OMGTx	120/208Y 120/208	34 39.4	12200 8200	50/60	3 4	1 3	2 (See Note 6)	4000W/208V

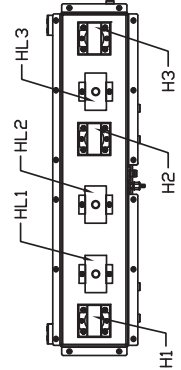

- TO CONVERT FROM THREE PHASE TO SINGLE PHASE, WHERE ONLY TWO HEATER ELEMENTS WILL BE ENERGIZED, REMOVE THE JUMPER CAP FROM WIRE FROM TERMINAL L3 OF THE POWER BLOCK AND CONNECT TO TERMINAL L2 OF THE POWER BLOCK.
 - LOOP CURRENT SENSOR THROUGH L1.
 - USE THIS DIAGRAM FOR ALL OTHER MODELS WITH ADDED PREFIX LETTERS AND/OR SUFFIX NUMBERS ON THEIR PART NUMBERS HAVING THE SAME ELECTRICAL RATINGS.
 - LOCATE MATED CONNECTORS AWAY FROM HEAT.
 - INSTALL GROUND WIRE ON UPPER RIGHT STUD ON TANK.
 - ALL WIRES SHALL BE MIN 18AWG PVC/UL1015 UNLESS NOTED.
- NOTES: UNLESS OTHERWISE SPECIFIED

TITLE	REVISION
LADDER DIAGRAM CONTROL AND HEATER CIRCUIT	F

OMGT10

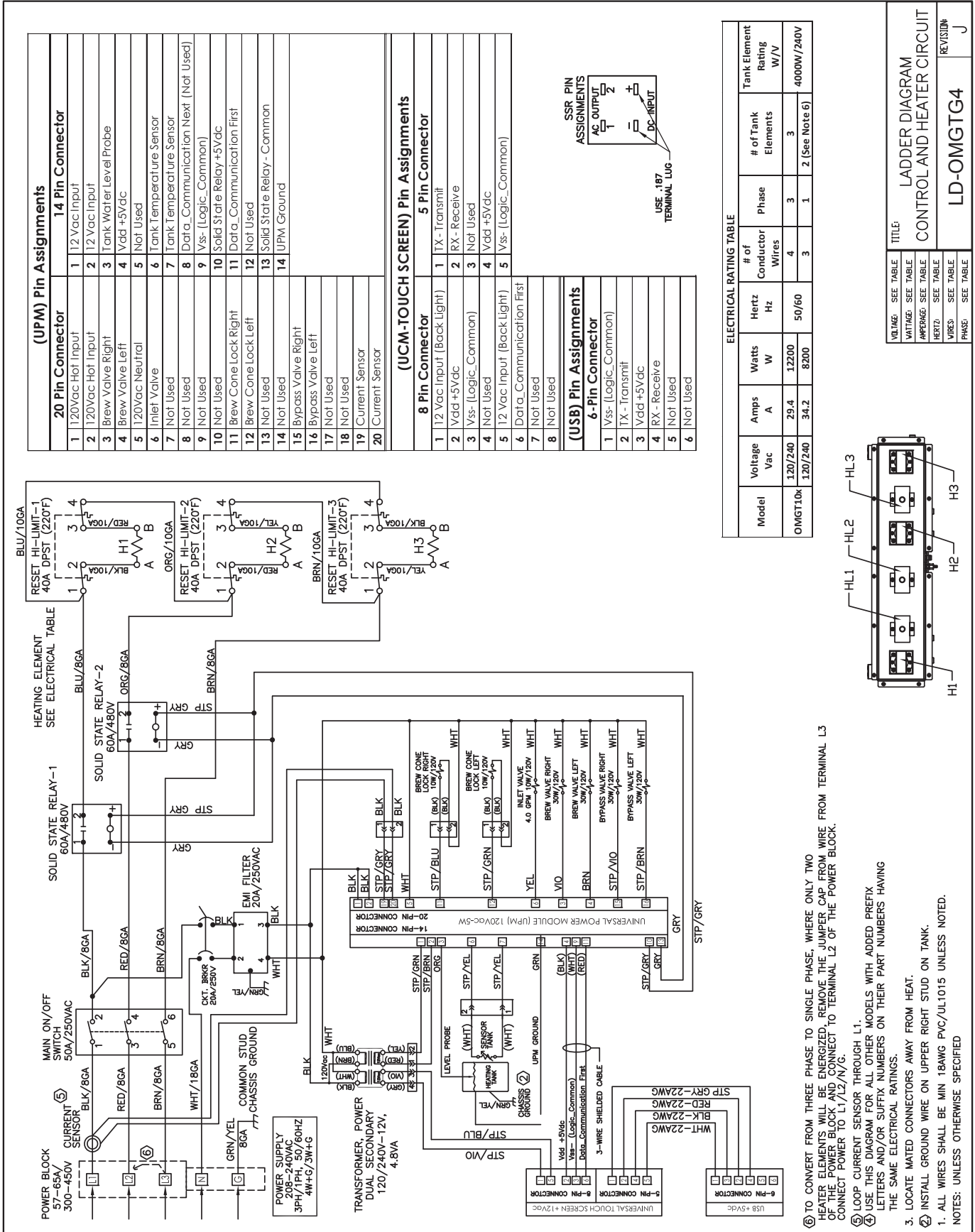

OMGT16

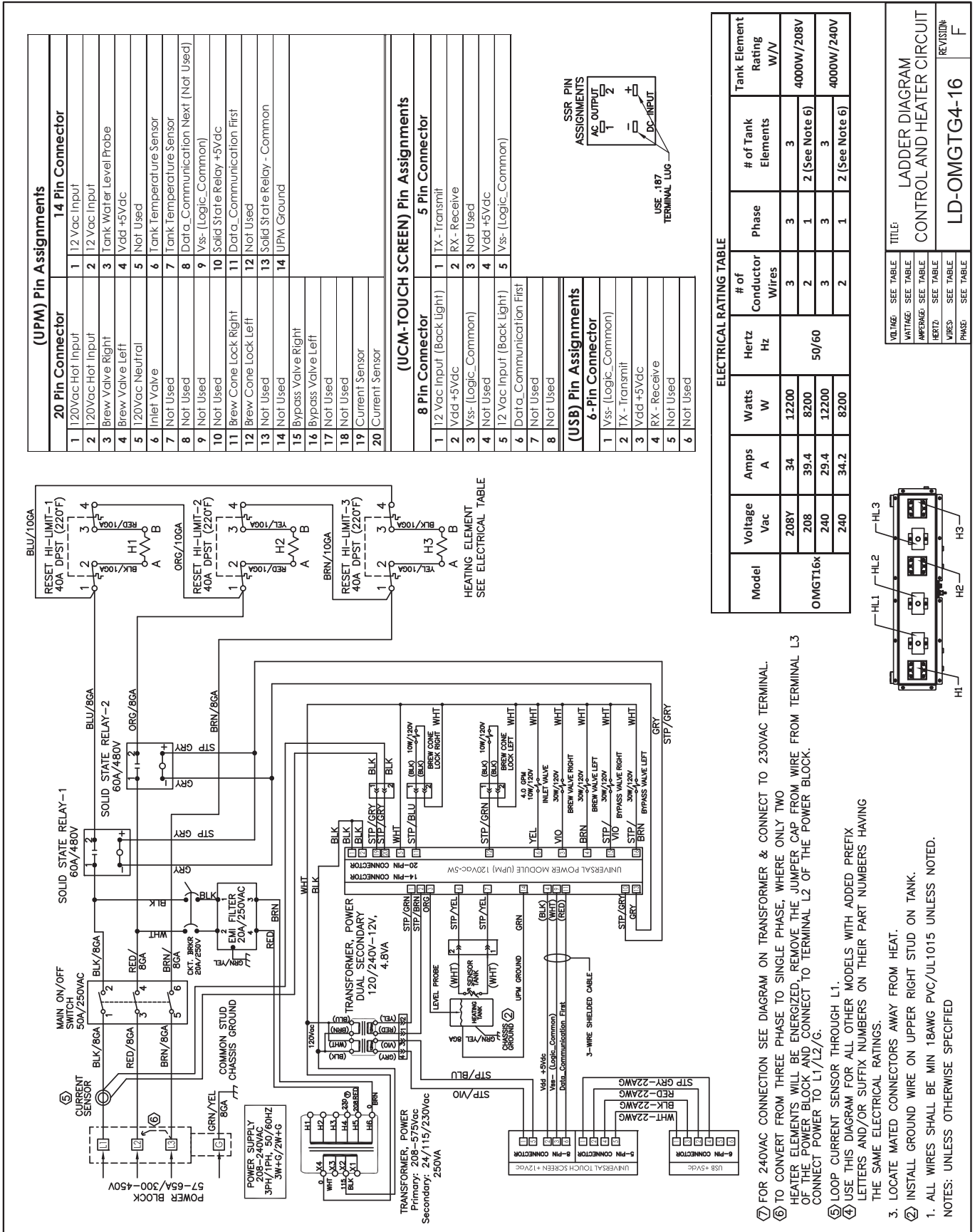

OMGT16

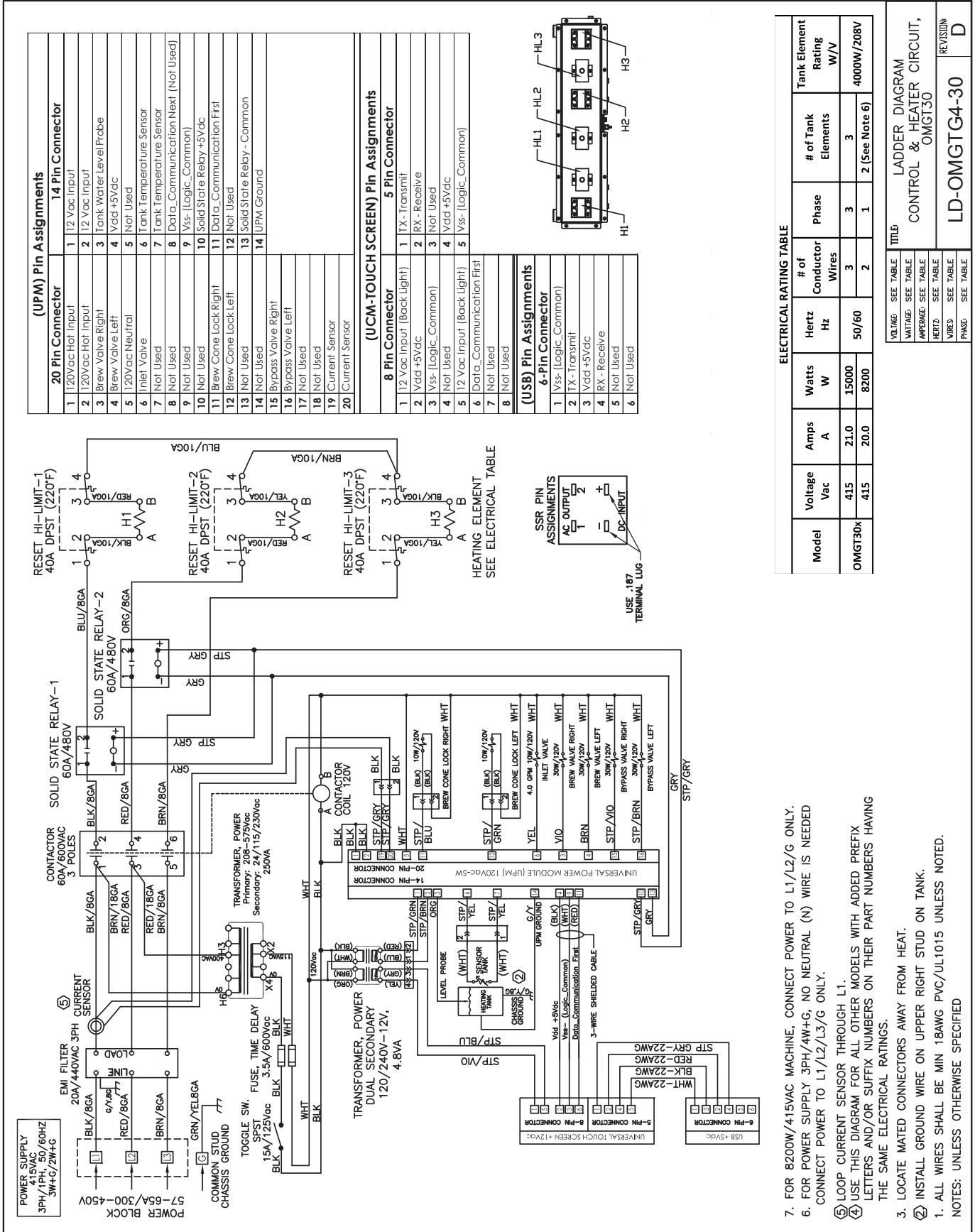

- FOR 8200W/415VAC MACHINE, CONNECT POWER TO L1/L2/G ONLY.
 - FOR POWER SUPPLY 3PH/4W+G, NO NEUTRAL (N) WIRE IS NEEDED. CONNECT POWER TO L1/L2/L3/G ONLY.
 - LOOP CURRENT SENSOR THROUGH L1.
 - USE THIS DIAGRAM FOR ALL OTHER MODELS WITH ADDED PREFIX LETTERS AND/OR SUFFIX NUMBERS ON THEIR PART NUMBERS HAVING THE SAME ELECTRICAL RATINGS.
 - LOCATE MATED CONNECTORS AWAY FROM HEAT.
 - INSTALL GROUND WIRE ON UPPER RIGHT STUD ON TANK.
 - ALL WIRES SHALL BE MIN 18AWG PVC/JUL1015 UNLESS NOTED.
- NOTES: UNLESS OTHERWISE SPECIFIED

**WARNING:**

Electric Shock Hazard - the following procedures are to be performed only by a qualified service technician. Turn off power when replacing components. Neither Wilbur Curtis Co., Inc. nor the seller can be held responsible for the interpretation of this information, or any liability in connection with its use.

Scald and Burn Hazard - keep body parts clear of hot surfaces during troubleshooting.



IMPORTANT: If it is necessary to replace the G4 universal power module (UPM), always check all inlet, dump (brew), bypass* and dilution* valve coils for a short and replace the valve as necessary, before replacing the module. See the **Valve Test Procedure**, below to test for defective valves. *Some units do not have this function, see the ELECTRICAL SCHEMATIC.

Troubleshooting Guidelines

- If an error message appears on the display, consult the ERROR CODES section before troubleshooting.
- A brewer that is not level may not function properly. Make sure the brewer is properly leveled before proceeding.
- This troubleshooting guide identifies some, but not all, of the possible causes for common problems that can occur.
- Use this troubleshooting guide along with the appropriate ELECTRICAL SCHEMATIC.

Valve Test Procedure

Use a digital multi-meter to measure the resistance of valve coils.

Measure the resistance across the valve coil terminals with the wiring harness disconnected. Reverse the meter leads on the terminals and measure the resistance in the opposite direction. A resistance of less than 100 ohms, in either direction, indicates a shorted coil. The valve must be replaced.

If a shorted coil is not detected, test for an open coil:

- 1 Reconnect the valve terminals to the wiring harness.
- 2 Power up the brewer and test the valve using the diagnostics in section TG11.

Water Not Hot Enough

- 1 If the water heats, but is not hot enough, first check for the correct temperature setting on the control panel. Reprogram as necessary.
- 2 If the temperature setting is OK, and the actual water temperature does not match setting on the control panel, replace the temperature sensor.

Water Heats More Slowly Than Usual

- 1 Check for power across the terminals of the heating element(s). If power is being supplied, disconnect the heating element(s) and check for continuity. Replace a heating element if the resistance is too high (nominal resistance is 13 Ohms).
- 2 If there is no power to the heating element(s), check the wiring to any element that does not have the proper voltage across it. Also check for corroded connections anywhere between the power cord and the heating element(s).

Dispenser Overflows During Brewing

- 1 Check to make sure the control module (UCM) brew, bypass* and dilution* levels are set properly.
- 2 Check for a missing spray head. Replace as needed.
- 3 Make sure the dispenser is empty before starting the brew cycle. If not, empty it before brewing.

*Some units do not have this function, see the ELECTRICAL SCHEMATIC.

No Power - Display Not Lit

- 1 Make sure the circuit breaker to the circuit supplying power to the brewer is not tripped and is turned on.
- 2 On brewers with a power plug, make sure it is connected to the power receptacle.
- 3 Make sure that the main power toggle switch on the back panel is turned ON.
- 4 Verify that all wires from the power cord are properly connected inside the unit. Check to make sure the wires are not burned/overheated. Check chassis ground.
- 5 Check the low voltage input to the universal control module (UCM) from the transformer (see the ELECTRICAL SCHEMATIC). If there is power into the UCM, but the display is blank, the UCM is probably bad.
- 6 If there is no power into the UCM, trace the circuit back (using the wiring diagram) to the power cord to find out where power is lost. If there is power into the thermostat reset switch, but not out, see step 7.
- 7 If there is power into the thermostat reset switch, but not out, check to make sure that the water tank is not empty. If the tank is empty, the reset switch has probably opened up due to a low water level, go to **Water Tank Does Not Fill**. If there is water in the tank, but no power out, push in on the reset switch button to see if it restores power. If power is restored, check to make sure that the switch is not opening up at the wrong temperature (the switch should not open up at normal water temperatures). If there is still no power through the switch after pushing the button, replace the thermostat reset switch.

Brewer Does Not Start When Brew Button is Pressed

- 1 If **Brewing** appears on the display, check for faulty wiring and connections between the universal power module (UPM) and the valves.
- 2 If **Brewing** does not appear on the display, check for a faulty universal control module (UCM) or universal power module (UPM).

Sensor Error Message

This error indicates a malfunction (open circuit) in the temperature sensor system. Once the malfunction is corrected, the error message must be cleared. To reset the brewer and return to normal operation, turn the toggle switch on the back of the brewer to the OFF position for 5 seconds, then back ON.

- 1 Check the resistance across the leads of the temperature sensor while it is disconnected from the universal power module (UPM). If an open circuit is measured (resistance above 200 k), replace the sensor.
- 2 If the sensor resistance is less than 200 k check the sensor wires for corrosion and reconnect them to the UPM. Afterward, if the error message comes back after resetting the control and power modules, replace the UPM.

Water Tank Overfills

- 1 Turn the toggle switch on the back of the brewer ON and OFF. If water continues to flow when the switch is in both positions, replace the inlet valve.
- 2 If water stop flowing to the water tank when the toggle switch is turned OFF and continues when the switch is turned back ON, remove the orange wire from the water probe on the tank. While power is ON, short the end of the orange wire to the metal surface on the outside of the tank. If the water tank stops filling when the orange wire is shorted to the tank, check for a corroded connection at the water probe.
- 3 If water does not stop flowing when the orange wire is shorted to the tank, check the tank ground connection and the continuity of the orange wire connecting to the universal power module (UPM). If both are OK, replace the UPM.

Water Tank Does Not Fill



IMPORTANT: No water or low water in the tank can cause the tank to overheat, resulting in the thermostat reset switch opening. If after correcting a tank fill problem there is no power to the control panel, push the reset switch button to reset.

- 1 Check to make sure the water supply is turned on. Check for a plugged water supply line or plugged inlet valve.
- 2 If there are no plugs in the water supply line, check for power across the inlet valve terminals. If power is being supplied, but there is no water flow, replace the inlet valve.
- 3 If power is not being supplied to the inlet valve, check the wires between the universal power module (UPM) and the inlet valve. Check for corroded connections.
- 4 If the wiring between the UPM and the inlet valve is OK, but there is no power to the inlet valve, remove the orange wire from the water tank probe. If the water tank starts to fill, replace the water probe. If the water tank does not start to fill, replace the UPM.

Coffee/Tea Too Strong

See *Dispenser Not Filled To Normal Level During Brewing*.

Dispenser Not Filled To Normal Level During Brewing

- 1 Check to make sure that the universal control module (UCM) brew, bypass* and dilution* levels are set properly.
- 2 Check to make sure that the flow rate and water pressure from the water supply line meet the minimum specifications for the brewer. See the SPECIFICATIONS section.
- 3 Check to make sure that the spray head is clean and free of debris. Clean or replace as needed. Also make sure that the spray head is correctly aligned and that the tubing is routed properly to allow for maximum water flow (no kinks).
- 4 Remove the brew basket and place a large container under the dump (brew) and dilution outlet points. Run a brew cycle and confirm that the dump (brew) valve, bypass* valve and dilution* valve open during the brew cycle. Check for flow through any exit point that is slow or non-existent. Not all valves open at the same time. If flow is restricted, check for obstructions in the related tubing or valve. If there are no obstructions, but flow through one particular valve is slow, it can be assumed that the particular valve is not opening all the way and should be replaced. If water does not flow at all through a particular valve during the brew cycle, check to make sure that power is being supplied to the valve in question. Replace any valve that is not opening when power is applied to the terminals. If power is not being supplied to the valve, check the wiring between the valve and the universal power module (UPM). If the wiring is OK, replace the UPM.

*Some units do not have this function, see the ELECTRICAL SCHEMATIC.

Dispenser Overflows All Of The Time

- 1 Check to see if water continues to flow from the spray head, the bypass* outlet or the dilution* spout when the toggle switch is turned OFF. Replace any valve that is stuck open.
*Some units do not have this function, see the ELECTRICAL SCHEMATIC.
- 2 If one or more of the valves mentioned in step 1 turns on when the toggle switch on the back is ON and turns off when the switch is OFF, replace the universal power module (UPM).

No Water/Tea Flows From Brewer During Brewing

- 1 Make sure that the water supply is turned on.
- 2 Check to see if the water in the tank is level with the water tank probe? If not, see *Water Tank Does Not Fill*.
- 3 If the water tank is full, the water is hot and power is on, but NO water flows during a brew cycle, the problem is usually a bad universal power module (UPM). Run a brew cycle and check for power from the UPM to the dump (brew), bypass* and dilution* valves. If there is no power output, replace the UPM.
*Some units do not have this function, see the ELECTRICAL SCHEMATIC.

Low Water Flow Warning

See *Water Level Error Message*.

Water Level Error Message

Water level fill error or overflow. This error message occurs when the inlet valve solenoid has been on too long during initial fill or tank refill, See the ERROR CODES section for the maximum times allowed. Once the malfunction is corrected, the error message must be cleared. To reset the unit and return to normal operation, turn the toggle switch on the back of the brewer to the OFF position for 5 seconds, then back ON.

- 1 Check to make sure that the flow rate from the water supply line meets the minimum flow rate specifications for the brewer. Also check the water pressure. See the SPECIFICATIONS section.
- 2 Check for blockage at the inlet valve inlet or outlet. Check for blockage in the tubing between the inlet valve and the water tank.
- 3 Check the water probe wire for an open condition or corroded connections.
- 4 If the probe connections are OK, cycle power to the unit by turning the rear toggle switch OFF, then ON. Check to see if power is applied to the inlet valve terminals. If power is applied to the terminals, but there is not water flow, replace the iDLETnlet valve.
- 5 Check for power from the universal power module (UPM) to the inlet valve. If the wiring is OK, replace the UPM.

“Internal Error 1” Message on Display

Check the wiring harness that connects from pins 4, 9 and 11 of the 14-pin connector on the universal power module (UPM) to pins 2, 3 and 6 of the 8-pin connector on the universal control module (UCM).

“Internal Error 2” Message on Display

The universal power module (UPM) and universal control module (UCM) have a mismatch in their settings. A firmware update is needed. See *PROGRAMMING GUIDE*.

Water Does Not Heat At All

- Check to see if the water level in the tank is in contact with the water level probe. If not, see *Tank Does Not Fill*. The water will not heat unless it is in contact with the probe.
- If the water heats, but is not hot enough, see *Water Not Hot Enough*.
- If **Ready to brew** appears on the display, but the water is not hot, check the resistance across the leads of the temperature sensor. If the resistance is less than 10 k and the water is not hot, replace the temperature sensor. If the sensor resistance is above 10 k when the water is cool, replace the universal power module (UPM).

If **Heating...** appears on the display, but the water is not hot, follow the steps below. The following steps are performed with the rear toggle switch in the ON position.

- 1 Check for power across the terminals of the heating element(s). If power is being supplied, remove the wires and check for an open heating element.
- 2 If there is no power to the element(s), trace the circuit back (using the ELECTRICAL SCHEMATIC) to the power cord to find out where power is lost. If there is power into the solid state relay(s) (SSRs) but not out, see the following step. On units having two SSRs, be sure to check both.
- 3 If there is power into a SSR, but not out, check for 5 Vdc (nominal*) across the + and - pins of the SSR(s). If there is 5 Vdc across the + and - pins of the SSR(s), but no (or low) output voltage at a SSR output terminal, replace the SSR. If 5 Vdc is not being supplied from the UPM, but **Heating...** appears on the display, check the wiring from the UPM to the SSR(s). If the wiring is OK, replace the UPM.

Water Too Hot (Boiling or Excessive Steaming)



IMPORTANT: Before proceeding, make sure that the control panel temperature is adjusted to compensate for higher elevations. The factory setting is 200°F. Reduce the temperature setting two degrees for every 1000 feet of elevation above 4000 feet.

- 1 If **Over Temp Sensor** or **Ready to Brew** appears on the display and the water is too hot, go to *Over Temp Sensor Error Message*.
- 2 If the display reads **Heating** constantly, first check to make sure that the temperature sensor is attached tightly to the tank and that heat sink compound was used. A properly mounted sensor should have a resistance of around 7 k when the water is hot. If not, replace the sensor.
- 3 Check to see if the universal power module (UPM) constantly has +5 Vdc (nominal) output to the solid state relay (SSR), regardless of the resistance of the temperature sensor. If so, the UPM is probably bad.
- 4 If the UPM is working properly, check for a shorted SSR.

Over Temp Sensor Error Message

This error message indicates that the universal control module (UCM) has detected a water overheating problem. The universal power module (UPM) is reading a water temperature in the tank above 210°F. If the water temperature is too hot, but **Heating...** appears on the display, see *Water Too Hot*. Once the malfunction causing the error is corrected, the error message must be cleared. To reset the brewer and return to normal operation, turn the toggle switch on the back of the brewer to the OFF position for 5 seconds, then back on.

- 1 Check for 5 Vdc (nominal) across the + and - pins of the solid state relay (SSRs). If no power is applied to the SSR and the heating elements are always on, replace the SSR. On units having two SSRs, check both.
- 2 Turn off power to the brewer and allow the water tank to cool. Once cool, turn power back on while monitoring the voltage across the + and - pins of the SSR(s). During normal operation, the voltage should be 5 Vdc, until the water is hot, then drop to below 1 Vdc. The universal power module (UPM) should be replaced if the voltage reads 5 Vdc constantly even though **Ready to brew** or **Over Temp Sensor** appears on the display.
- 3 If the UPM is operating normally, check for a false over-temp error caused by the temperature sensor. Check the resistance across the leads of the temperature sensor. If the resistance is less than 10 k when the water is cool, replace the temperature sensor.

Overview

The G4 control module diagnostics can be used to detect electrical circuit failures in the brewer. When a circuit failure is identified, the individual components and wiring in the circuit must be checked to determine the exact cause of the failure using the ELECTRICAL SCHEMATIC. If a failure is not detected using the diagnostics, troubleshoot the problem according to the symptoms listed in other sections of this TROUBLESHOOTING GUIDE.

The diagnostics can also be used to help diagnose certain mechanical failures. See the following steps.

Using the Diagnostics

- 1 Enter programming mode by tapping the (white) Curtis logo on the touchscreen five (5) times.
- 2 Enter the access code, then press **OK** (the default code is 1 2 3 4).
- 3 The **MAIN MENU** screen will appear. Press **Control Settings**.
- 4 Press **Diagnostics**. When prompted, place an empty container under the brew basket, then press **OK**.
- 5 Press a button to test the desired circuit or **Auto Test** to test all circuits. If a button is highlighted green the circuit has passed the (electrical) test. If the button is highlighted red, the circuit has failed the test.

If the circuit tested fails, check to make sure that power is being supplied to the component during normal operation. If power is supplied, and it does not operate, replace the component. If power is not being supplied, check the wiring and the UPM.

If a valve circuit passes the test, check for a mechanical failure by listening for the valve to “click” when the test button is pressed. To check for a failed pump run a brew cycle and check for fluid flow through the pump.



Curtis logo

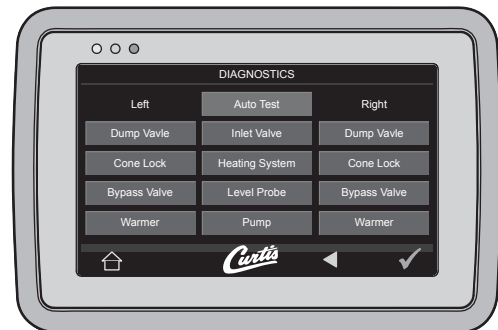

Diagnostics Screen

Button layout varies based model

Warning Messages - Allows Brewer to Continue Brewing

MESSAGE DISPLAY	WARNING DESCRIPTION	CAUSE
Maintenance Required	Maintenance Required	Brew count "Gallons Since Reset" exceeds programmed preventative maintenance period.
Low Water Flow Warning	Low Water Flow	If the Inlet valve remains on longer than XX seconds (during the brew cycle only) and repeats TWICE during that brew cycle. It shall clear upon the next brew and if the same low flow exists again, it will re-appear. XX = Alpha 20 secs; Gem/TP Twin 40 secs; Gem/TP Single 30 secs.
Internal Error 2	UPM-UCM have a mismatch in their settings.	UPM-UCM have a mismatch in their settings, firmware update needed.

Error Messages - Brewer Will Stop Brewing

MESSAGE DISPLAY	ERROR DESCRIPTION	CAUSE
Water Level Error	Fill run error/Overflow	The water inlet valve has either been open for more than 10 minutes on the initial tank fill or has been open for 120 seconds on large brewers and 30 seconds on CGC, tea brewers in normal operation.
Sensor Error	Open Sensor	Break in the temperature thermistor circuit or short circuit.
Over Temp. Error*	Excess Temperature	The sensor is reading that temperature in the heating tank has risen above 210°F, or sensor has shorted to ground.
Internal Error 1	UPM-UCM Communication	Break in the UPM-UCM communication circuit.

* This error is disabled on CGC and Seraphim® models.

Configuration Error Message - Brewer Will Not Function Properly

MESSAGE DISPLAY	ERROR DESCRIPTION	CAUSE
Configuration Error	UPM software revision does not support the model selected.	The universal power module (UPM) has an old software version and is not compatible with the brewer model in which it has been installed.

Wilbur Curtis Co., Inc. certifies that its products are free from defects in material and workmanship under normal use. The following limited warranties and conditions apply:

- 3 years, parts and labor, from original date of purchase on digital control boards
- 2 years, parts, from original date of purchase on all other electrical components, fittings and tubing
- 1 year, labor, from original date of purchase on all other electrical components, fittings and tubing

Additionally, Wilbur Curtis Co., Inc. warrants its grinding burrs for forty (40) months from the date of purchase or 40,000 pounds of coffee, whichever comes first. Stainless steel components are warranted for two (2) years from the date of purchase against leaking or pitting. Replacement parts are warranted for ninety (90) days from the date of purchase or for the remainder of the limited warranty period of the equipment in which the component is installed.

All in-warranty service calls must have prior authorization. For authorization, call the Technical Support Department at 800-995-0417. Additional conditions may apply. Go to www.wilburcurtis.com to view the full product warranty information.

CONDITIONS & EXCEPTIONS

The warranty covers original equipment at time of purchase only. Wilbur Curtis Co., Inc., assumes no responsibility for substitute replacement parts installed on Curtis equipment that have not been purchased from Wilbur Curtis Co., Inc. Wilbur Curtis Co., Inc. will not accept any responsibility if the following conditions are not met. The warranty does not cover:

- **Adjustments and cleaning:** *The resetting of safety thermostats and circuit breakers, programming and temperature adjustments are the responsibility of the equipment owner. The owner is responsible for proper cleaning and regular maintenance of this equipment.*
- **Replacement of items subject to normal use and wear:** *This shall include, but is not limited to, spray heads, faucets, light bulbs, shear disks, "O" rings, gaskets, silicone tubing, silicone elbows, canister assemblies, whipper chambers and plates, mixing bowls, agitation assemblies and whipper propellers.*

The warranty is void under the following circumstances:

- **Improper operation of equipment:** *The equipment must be used for its designed and intended purpose and function.*
- **Improper installation of equipment:** *This equipment must be installed by a professional technician and must comply with all local electrical, mechanical and plumbing codes.*
- **Improper voltage:** *Equipment must be installed at the voltage stated on the serial plate supplied with this equipment.*
- **Improper water supply:** *This includes, but is not limited to, excessive or low water pressure and inadequate or fluctuating water flow rate.*
- **Damaged in transit:** *Equipment damaged in transit is the responsibility of the freight company and a claim should be made with the carrier.*
- **Abuse or neglect (including failure to periodically clean or remove lime accumulations):** *The manufacturer is not responsible for variation in equipment operation due to excessive lime or local water conditions. The equipment must be maintained according to the manufacturer's recommendations.*

Repairs and/or Replacements are subject to Curtis' decision that the workmanship or parts were faulty and the defects showed up under normal use. All labor shall be performed during regular working hours. Overtime charges are the responsibility of the owner. Charges incurred by delays, waiting time, or operating restrictions that hinder the service technician's ability to perform service is the responsibility of the owner of the equipment. This includes institutional and correctional facilities. Wilbur Curtis Co., Inc. will allow up to 100 miles, round trip, per in-warranty service call.

Return Merchandise Authorization (RMA): All claims under this warranty must be submitted to the Wilbur Curtis Technical Support Department prior to performing any repair work or return of this equipment to the factory. **All returned equipment must be properly re-packaged in the original carton and received by Curtis within 45 days following the issuance of a RMA.** No units will be accepted if they are damaged in transit due to improper packaging. **NO UNITS OR PARTS WILL BE ACCEPTED WITHOUT A RETURN MERCHANDISE AUTHORIZATION (RMA). THE RMA NUMBER MUST BE MARKED ON THE CARTON OR SHIPPING LABEL. All warranty claims must be submitted within 60 days of service. Invoices will not be processed or accepted without a RMA number. Any defective parts must be returned in order for warranty invoices to be processed and approved.** All in-warranty service calls must be performed by an authorized service agent. Call the Wilbur Curtis Technical Support Department to find an agent near you.