

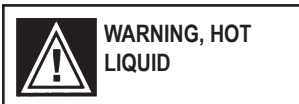

## Primo Cappuccino System Instructions

### Models Included

- PC-4D
- PC-3D
- PC-2D
- PC-1D
- HC-1D

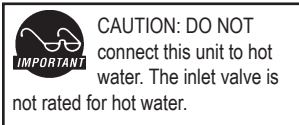
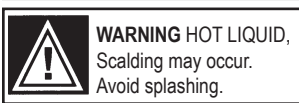

### Important Safeguards/Conventions

This appliance is designed for commercial use. Any servicing other than cleaning and maintenance should be performed by an authorized Wilbur Curtis service center.

- Do NOT immerse the unit in water or any other liquid
- To reduce the risk of fire or electric shock, do NOT open top panel. No user serviceable parts inside. Repair should be done only by authorized service personnel.
- Keep hands and other items away from hot parts of unit during operation.
- Never clean with scouring powders or harsh implements.

### Conventions



**WARNINGS – To help avoid personal injury**



**Important Notes/Cautions – from the factory**



**Sanitation Requirements**

Your Curtis ADS System is Factory Pre-Set and Ready to Go... Right from the Carton.

Following are the Factory Settings for your ALPHA™ DS Coffee Brewing Systems:

- Tank Temperature = 190°F
- Flavor Controls= Set at 100%
- Dispensing Mode Set for Manual Dispensing

Generally there will never be a reason to change your ADS programming. However, should you need to make slight adjustments to meet your brewing needs, programming instructions are provided later in this manual.

System Requirements:

- Water Source 20 – 90 PSI (Minimum Flow Rate of 1 GPM)
- Electrical: See attached schematic for standard model or visit [www.wilburcurtis.com](http://www.wilburcurtis.com) for your model.

Equipment to be installed to comply with applicable federal, state, or local plumbing/electrical codes having jurisdiction.

### SETUP STEPS

The unit should be level (left to right and front to back), located on a solid counter top. Connect a water line from the water filter to the brewer. NOTE: Some type of water filtration device must be used to maintain a trouble-free operation. (In areas with extremely hard water, we suggest that a sedimentary and taste & odor filter be installed.) This will prolong the life of your brewing system and enhance coffee quality.



The National Sanitation Foundation requires the following water connection:

1. A quick disconnect or additional coiled tubing (at least 2x the depth of the unit) so that the machine can be moved for cleaning underneath.
2. In some areas an approved backflow prevention device may be required between the brewer and the water supply.

1. Connect a water line from your facility to the 1/4" flare water inlet fitting of the valve, behind the machine. Water volume going to the machine should be stable. Use tubing sized sufficiently to provide a minimum flow rate of one gallon per minute.
2. Plug the power cord into an electrical outlet rated at 20A.
3. Switch on the CONTROL switch that runs power to the components in the machine. The lights (display window & row of buttons) on the front door will activate and the heating tank will start to fill.
4. Once the water level has risen and covered the heating element, turn on the power to the heating element at the HEATING ELEMENT switch behind the unit.
5. Water in the heating tank will require about 30 minutes to reach operating temperature (factory setting of 190°F). At this time the READY light will come on.
6. Remove and fill the canisters with powdered cappuccino mixes.

### OPERATION INSTRUCTIONS

1. Choose a flavor. Place your cup under the spout beneath the desired flavor.
2. Push the dispensing button for this flavor.
3. Allow the Primo Cappuccino unit time to completely dispense the product.

### FILL CANISTERS DAILY

1. Open the front door to access canisters.
2. The canisters must be removed from the unit for filling. The rectangular canisters hold approximately four pounds of product. Each round cannister will hold approximately six pounds of product.
3. Reposition the canisters on the machine, aligning the gear socket with the motor shaft. The pin under the canister must align with the guide hole on the support shelf.

# Control Board and Membrane Control Panel

## FUNCTIONS OF THE CONTROL BOARD

- GEAR MOTOR SPEED** is a powder dispensing adjustment and is accessed by mode level no. 1 when programmed.
- PRESET DISPENSING** Product is dispensed at a measured amount when the PUSH button is pressed.
- MANUAL DISPENSING** allows the user to dispense product for as long as the PUSH button is pressed.
- STOP** will cancel a preset dispense cycle.
- WASH CYCLE** is used in conjunction with a PUSH button, to flush the whipper chambers.
- HOT WATER DISPENSING** for tea, hot chocolate or other instant beverages (available on some models, not shown).

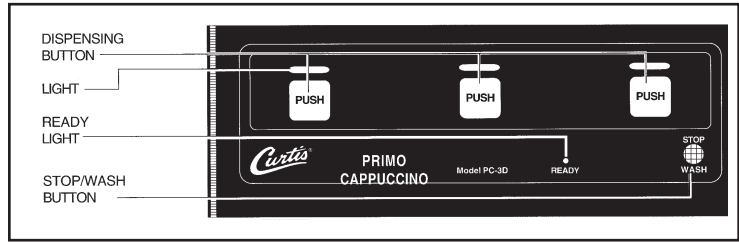

## PROGRAMMING

Programming Mode PC-2D, PC-3D, PC-4D

To enter the programming mode, press and hold any two of the PUSH buttons on the membrane control panel simultaneously, until all lights start blinking. Then release the buttons and choose any mode of operations for any of the PUSH buttons. Press STOP button if both PUSH buttons were not pressed simultaneously.

Programming Mode PC-1D

To enter the programming mode, press and hold the PUSH button and the STOP/WASH button on the membrane panel simultaneously, until the indicator light starts blinking. Then release the buttons and choose any mode of operation. Press STOP/WASH button if both buttons were not pressed simultaneously.

While in the programming mode you may perform the following three functions:

- Powder Dispensing Mode.** Controls dispensing powder anywhere from 10% to 100% by volume. Press and hold the selected PUSH button for approximately one second, then release. The number of flashes represent the set volume for this button (see table). To change the volume, press and hold the button until its light starts quick flashing. Each quick flash increases the volume by 10%. Release the button when the desired volume is achieved. After releasing the button, the number of blinks represent the new setting. To exit the Powder Dispensing Mode, push one of the other PUSH buttons.
- Preset Liquid Dispensing Mode.** This mode allows you to set the time for automatic dispensing. To select or change the timing while in the programming mode, press and hold the selected PUSH button until the liquid begins to flow, then release. The timing starts when liquid begins to flow. When the desired volume is achieved, press once again to stop the dispensing. You have now set the timing for this button and have exited the programming mode. If you press the selected button, it will dispense the liquid per your setting. To reset the timing, you must start from the programming mode.
- Manual Liquid Dispensing Mode.** While you are in the programming mode, press and hold the PUSH button, until the liquid stops flowing, then release the button. At this time, you have selected the Manual Liquid Dispensing Mode and have exited the programming mode.

NO. OF FLASHES	VOLUME
1	10%
2	20%
3	30%
4	40%
↓	↓
10	100%

**Wash Cycle Mode.** To wash a whipping chamber, hold the STOP/WASH button and press the PUSH button. Rinse water will dispense for as long as you hold in the STOP/WASH button. The STOP/WASH button stops the dispensing in automatic dispensing mode.

## HEATING ELEMENT TOGGLE SWITCH

The heating element in the heating tank may be turned off in the Primo Cappuccino to allow the operator to use the unit for cold drinks. Located behind the unit are two toggle switches. The one on the bottom is the power switch for shutting down the complete unit. The top switch powers the heating element. Flip down to turn it OFF. Up turns ON the element.

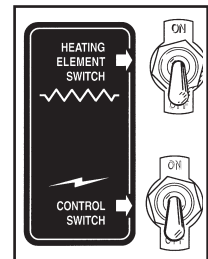

## ADJUSTING THE TEMPERATURE: Factory Setting 190°

The water level/temperature circuit board, WC-3777, serves two functions. As the name implies, it is both a thermostat and water level control. This electronic board maintains the water level using a probe in the tank. Water temperature in the tank is controlled by a sensor bolted on the outside of the tank, just under the heating element terminals.

- Open the front door. Remove the hinged top cover.
- Remove the left side panel.
- Locate the water level/temperature board, on the left side of the frame.
- Near the center of the board you will find a pair of tiny 'shorting plugs' attached to two pairs of pins (see illustration, right). Just above this is a chart that displays the various combinations you may choose that will give you temperatures between 170° F and 200° F. Pull out or insert the shorting plug in any configuration that will result in the desired temperature.
- Return the side panel and cover to on the unit.

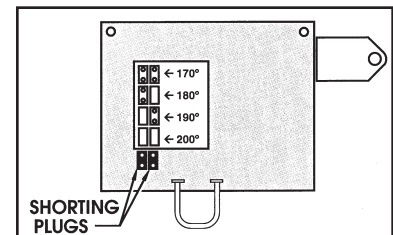

## DAILY CLEANING

- Wipe all exterior surfaces with a damp cloth; removing any spills, dust or debris from the unit.
- Pull out the drip drawer and screen. Wash out its contents. For hard to clean deposits, use a mild, nonabrasive solution of dishwashing detergent and water.
- Clean around the dispensing area, wiping with a nontoxic cleaner.

# PARTS DIAGRAMS

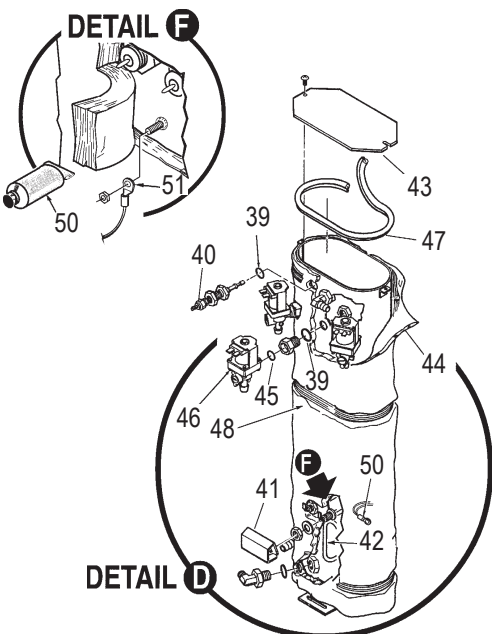
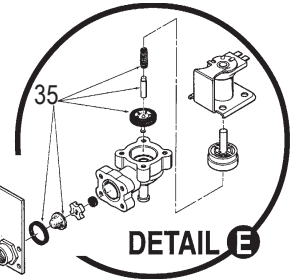
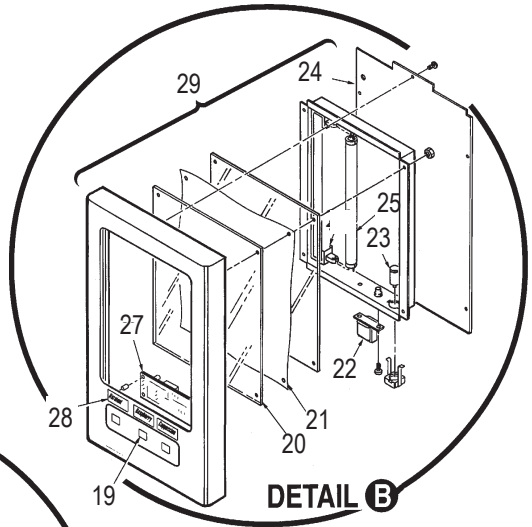
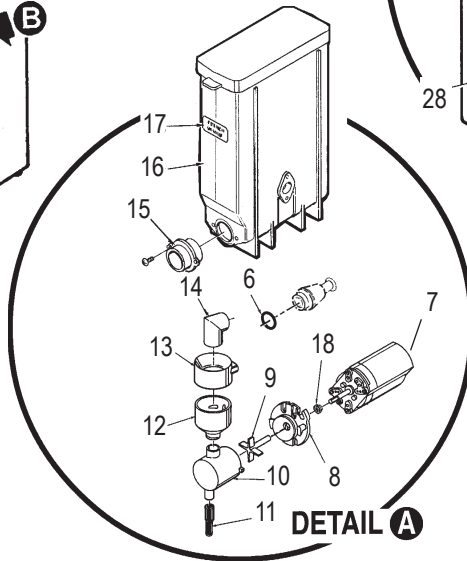
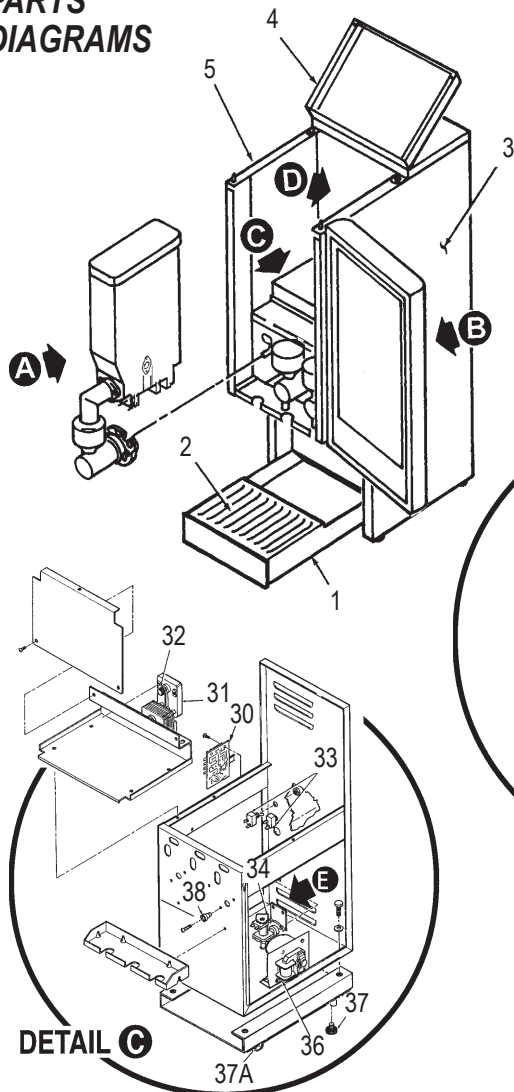

## Illustrated Parts List (PC-3D Model Shown)

Nº	Part Nº	Description	Nº	Part Nº	Description
1A	WC-6857	Drawer, Drip, PC-3D	24	WC-5930	Panel, Door w/Assy PC/CK-3D
1B	WC-6760	Drawer, Drip W/Assy PC-1D, 2D, HC-1D	25	CA-1018	Lamp, Fluorescent 8W FL8CW
1C	WC-6853	Drawer, Drip, PC-4D	26	CA-1016	Holder, Fluorescent Lamp
2A	WC-6633	Screen, Drip Drawer PC-3D	27A	WC-671	Control Board, 120V, PC-3D
2B	WC-6758	Screen, Drip Drwr PC-1D, PC-2D, HC-1D	27B	WC-673	Control Board, 120V, PC-3DHW
2C	WC-6848	Screen, Drip Drawer PC-4D	27C	WC-675	Control Board, 120V, PC-1D, HC-1D
3A	WC-6644	Panel Assy, Right Side Sub-Assy PC-3D	27D	WC-674	Control Board, 120V, PC-2D
3B	WC-6768	Wrap Right, PC-1D, PC-2D, HC-1D	27E	WC-681	Control Board, 120V, PC-4D
4A	WC-6645	Cover Assy, Top PC-3D	28	WC-39105-02	Label, Flavor Low Tack Door Gen Use
4B	WC-6747	Cover, Top Front, PC-1D/2D	29A	WC-5862	Door, Complete PC-3D
4C	WC-6746	Cover, Top Back, PC-1D/2D	29B	WC-5823	Door, Complete PC-2D
4D	WC-58020	Cover Assy, Top PC-4D	29C	WC-5861	Door, Complete PC-4D
5A	WC-6643	Panel, Left Assy, PC-3D/PC-4D	29D	WC-5834	Door, Complete PC-1D
5B	WC-6744	Panel, Left PC/HC-1D, PC-2D	30	WC-3777	Kit, Rpl Control Bd Wtr Lvl/Temp, 120V/220V
6	WC-43033	O' Ring, .394 I.D., .551 O.D., .075 TH	31	CA-1013	Motor, Gear Assy
7	WC-37014	Kit, Motor WhipperRetrofit PC/CK/HC	32	CA-1036	Gear, Plastic Use on CA-1013
8	WC-37118	Kit, Whipper Plate (3/pkg)	33	WC-102	Switch, Toggle 25A 125/250VAC
9	CA-1008-03	Propeller, Whipper PC/CK/HC	34	WC-826L	Valve, Inlet 1GPM 120V 10W
10	CA-1006-03	Chamber, Whipper PC/CK/HC	35	WC-3765L	Kit, Inlet Valve Repair (Use on WC-826L)
11	CA-1037B	Tube, Extension 3.48" Long Blk All PCs	36	WC-37123	Kit, Extract Fan 29 CFM & Bracket
12	CA-1009-03	Bowl, Mixing PC/CK/HC	37	WC-3518	Leg, Glide 3/8"-16 Stud Screw
13	CA-1005-03	Steam Trap, PC/CK/HC	37A	WC-3503	Leg, 3/8"-16 Stud Screw Bumper
14	CA-1026-03	Elbow, PC/CK/HC	38	CA-1024-05	Pillar, Location Black All PCs
15	CA-1065	Bushing, Discharging 4lb Canister	39	WC-4320	O' Ring, 1/2" I.D.
16A	CA-1000	Canister Assy, 4 lb., 6.7cc/sec	40	WC-5502	Probe, Water Level
16B	CA-1050	Canister Assy, Round 6 lb., PC/HC-1D	41	WC-4394	Guard, Shock, Heating Element
17	WC-39107-02	Label, Adhesive Canister Gen Use	42	WC-904-04	Element, Heat 1.6Kw, 120V W/Jam Nuts
18	WC-43791	Ring, Motor Shaft Plastic	43	WC-5851	Cover Tank w/Notches
19A	WC-39163	Membrane Control Panel, Curtis PC-3D	44	WC-3688	Insulation, Wrap PC-3/3D & PC-4/4D
19B	WC-39169	Membrane Control Panel, PC-3DHW	44A	WC-3690	Insulation, Wrap PC-1/1D & PC-2/2D
19C	WC-39171	Membrane Control Panel, PC-1D, HC-1D	45	CA-1039	O' Ring, Dump Valve (WC-880)
19D	WC-39170	Membrane Control Panel, PC-2D, 2DC1	46	WC-3734	Kit, Rpl Dump Valve (WC-880E)
19E	WC-39206	Membrane Control Panel, PC-4D	47	WC-43062	Gasket, Tank Lid
20A	CA-1022	Window, Outer Clear PC-3D/PC-4D	48A	WC-54102	Heating Tank Complete PC-3D
20B	CA-1060	Window, Outer Clear PC/HC-1D, PC-2D	48B	WC-54101	Heating Tank Complete PC-2D
21A	CA-1023-01	Film, Std Curtis Logo PC-3D/PC-4D	48C	WC-54100	Heating Tank Complete PC-1D
21B	CA-1061-01	Film, Generic PC-1/2 Cappuccino	49	WC-6188	Heat Sink Assy, PC-3D
21C	CA-1070-01	Film, Standard Curtis HC-1D	50	WC-1438	Sensor, Heating Tank
22	CA-1015	Transformer, 120V, 60 Hz, .18 A	51	WC-5231	Compound, Silicone 5 oz. Tube
23	CA-1020	Starter, Fluorescent Lamp PC/CK/HC			

