

Configuration #5
 Heater Circuit
 380-480VAC, 3PHASE
 4W+G

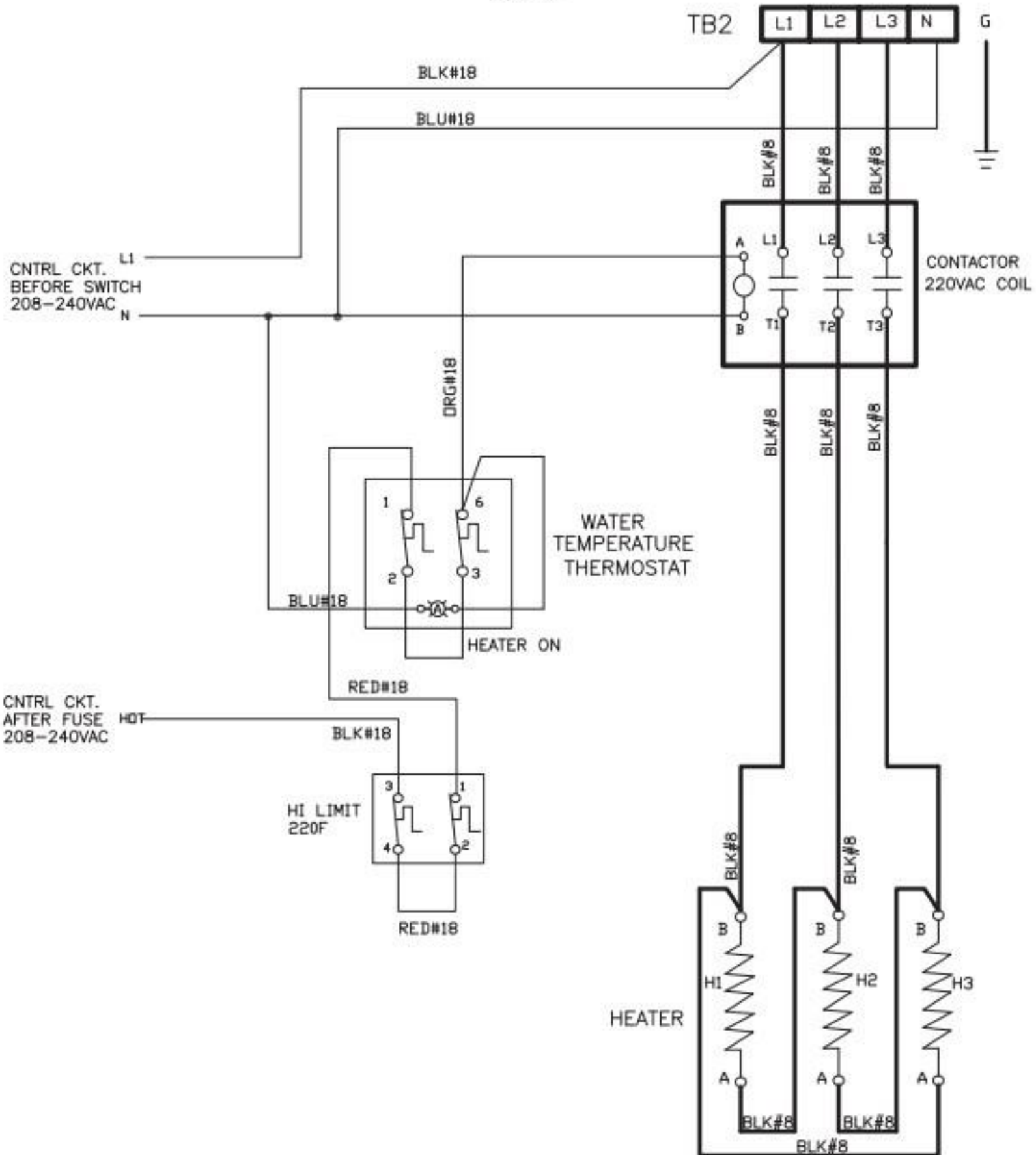

Configuration #11
 Heater Circuit
 Single Phase 2W+G

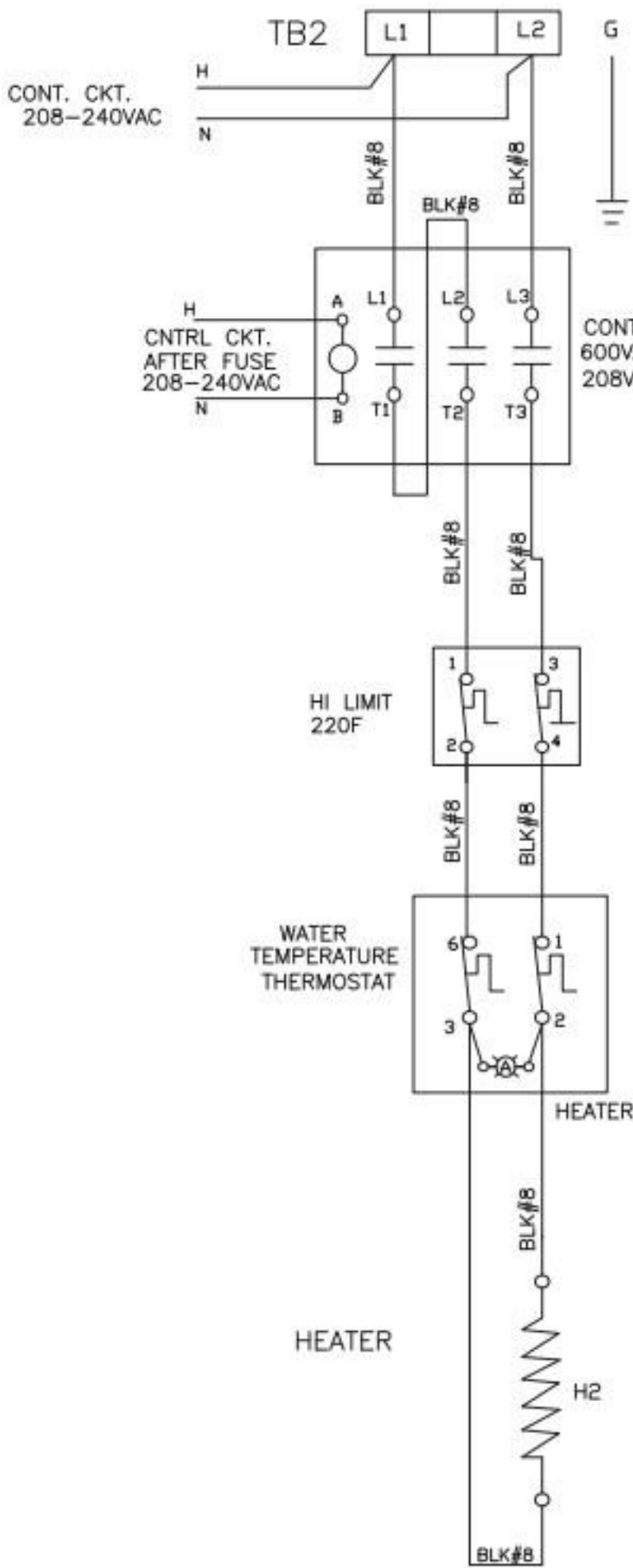

VOLTAGE:	SEE BOM
WATTAGE:	SEE BOM

TITLE: LADDER

Configuration #12
Heater Circuit
3PHASE 3W+G
With 120VAC POWER CORD CNTRL CIRCUIT

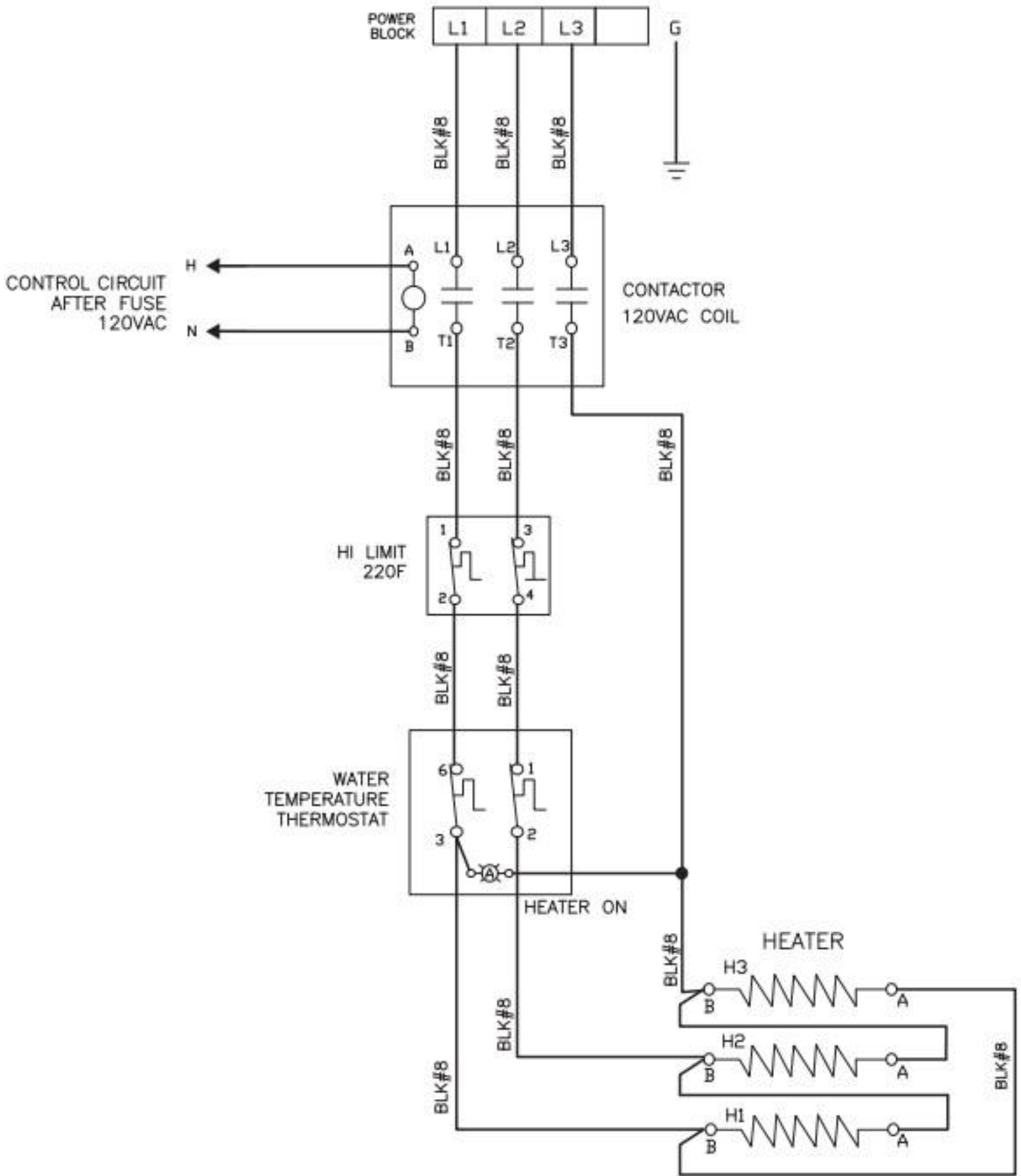

Configuration #3
Heater Circuit
Single Phase 3W+G

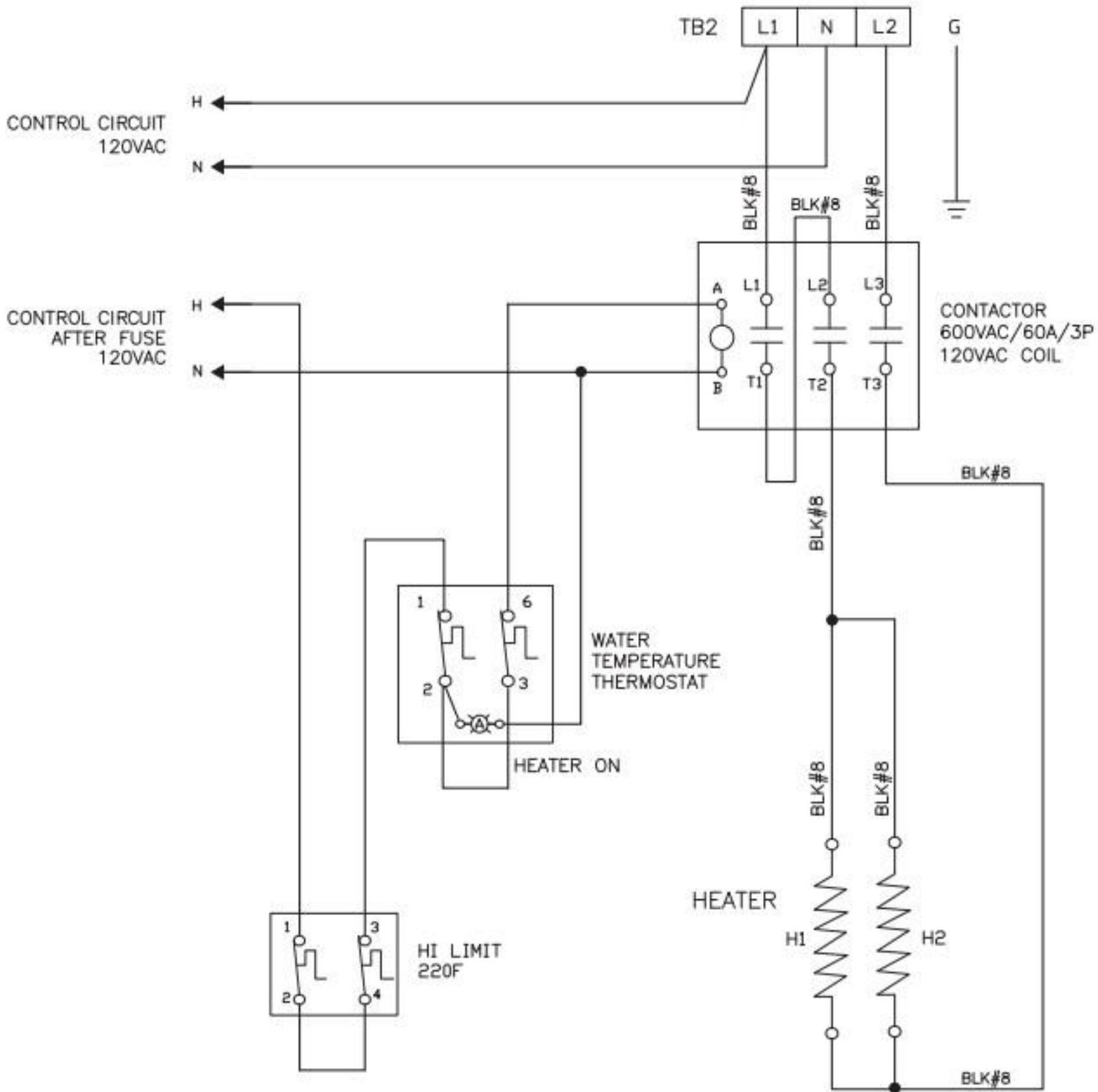

Configuration #1
Heater Circuit
Single Phase 3W+G

